

LOSSNAY

# HANDBOOK

---

## MODELS

VL-100U5-E

VL-100EU5-E

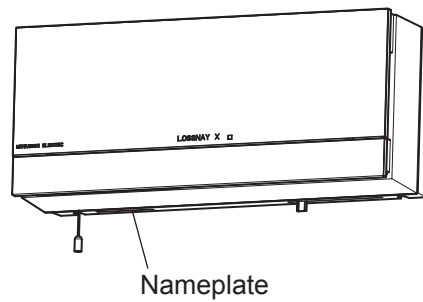

**Warning:**

Repair work must be performed by the manufacturer, its service agent or a similarly qualified person in order to avoid hazards.









**MITSUBISHI ELECTRIC CORPORATION**



# Contents

1. Safety precautions .....	3
2. Names and functions of components .....	4
3. Specifications .....	4
4. Outside dimensions .....	5
5. Electrical wiring diagrams .....	6
6. Troubleshooting .....	7-8
7. How to call .....	9
8. Service inspection list .....	9
9. Overhauling procedures .....	10-15
10. Parts catalog .....	16-24
VL-100U5-E .....	17-20
VL-100EU5-E .....	21-24

# 1. Safety precautions

- Read the following precautions thoroughly before the maintenance, and then inspect and repair the product in a safe manner.
- The types and levels of danger that may arise if the product is handled incorrectly are described with the warning symbols shown below.

 <b>Warning</b>		Incorrect handling of the product may result in serious injury or death.	
<p>◇ <b>Electric shock</b> If you must inspect the circuitry while the power is on, do not touch the live parts.</p> <p>(Failure to heed this warning may result in electric shock.)</p> <div style="text-align: right;">   <small>Caution against electric shock</small> </div>	<p>◇ <b>Turn off the power supply</b> Be sure to unplug the power cord, or shut off the circuit breaker before disassembling the unit for repair.</p> <p>(Failure to heed this warning may result in electric shock.)</p> <div style="text-align: right;">   <small>Be sure to follow this instruction.</small> </div>		
<p>◇ <b>Modification is prohibited</b> Do not modify the unit.</p> <p>(Failure to heed this warning may result in electric shock, fire and/or injury.)</p> <div style="text-align: right;">   <small>Prohibited</small> </div>	<p>◇ <b>Use proper parts and tools</b> For repair, be sure to use the parts listed in the service parts list of the applicable model and use the proper tools.</p> <p>(Failure to heed this warning may result in electric shock, fire and/or injury.)</p> <div style="text-align: right;">   <small>Be sure to follow this instruction.</small> </div>		
<p>◇ <b>Proper electric work</b> Use the electric wires designated for electric work, and conduct electric work in accordance with the "Electric Installation Engineering Standard", the "Indoor Wiring Regulations" and the installation instructions.</p> <p>(Improper connection or wiring installation may result in electric shock and/or fire.)</p> <div style="text-align: right;">   <small>Be sure to follow this instruction.</small> </div>	<p>◇ <b>Replace damaged and/or degraded parts</b> Be sure to replace the power cord and lead wires if they are damaged and/or degraded.</p> <p>(Failure to heed this warning may result in electric shock and/or fire.)</p> <div style="text-align: right;">   <small>Be sure to follow this instruction.</small> </div>		
	<p>◇ <b>Check insulation</b> Upon completing repair work, always measure the insulation resistance. Verify that it is at least 10 MΩ (with a 500 V DC insulation resistance tester), and then turn on the power.</p> <p>(Inadequate insulation may result in electric shock.)</p> <div style="text-align: right;">   <small>Be sure to follow this instruction.</small> </div>		

 <b>Caution</b>		Incorrect handling of the product may result in injury or damage to properties including buildings and equipment.	
<p>◇ <b>Caution for injury</b> Do not work at a location where you do not have a sure footing.</p> <p>(Failure to heed this caution may result in a fall.)</p> <div style="text-align: right;">   <small>Prohibited</small> </div>	<p>◇ <b>Wear gloves</b> Wear gloves when servicing.</p> <p>(Failure to heed this caution may result in injury to your hands from sharp metal or other edges.)</p> <div style="text-align: right;">   <small>Be sure to follow this instruction.</small> </div>		



## Request for repair

- Inspect the grounding, and repair it if it is incomplete. Make sure that a power supply isolator or an overload protection device is installed, if it is not installed, recommend the dealer to install one.
- Make sure that the product operates properly upon completion of repair. Clean the product and the surrounding area, and then notify the customer of the completion of repair.

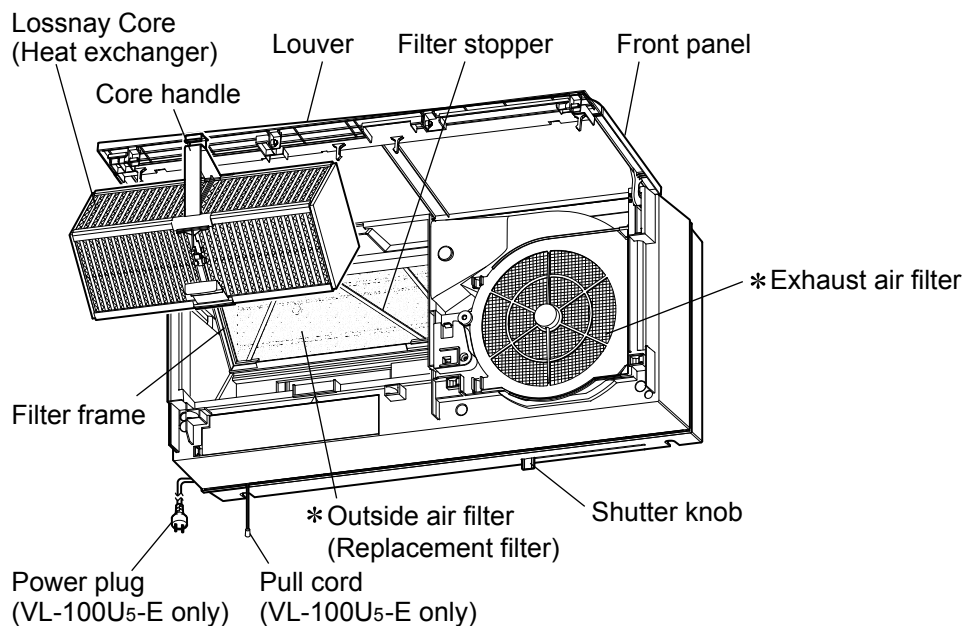
## 2. Names and functions of components

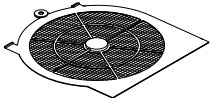

### \* About the filters

			Features
Exhaust air filter		Exhaust air side	The filter prevents clogging of the internal parts.
Outside air filter (Replacement filter)	 (P-100F5-E: Optional parts)	Supply air side	When Lossnay takes in outside air to a room, the filter collects dust, sand, pollen or the likes from outside air. Note: Some fine particles or tiny insects may pass through the filter. The high performance filter is recommended for higher collecting effect.

Outside air filter can be replaced with the following high performance filter.

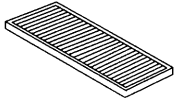
High performance filter (Optional parts)	 (P-100HF5-E)	Supply air side	The filter collects dust more efficiently than the outside air filter. Note: When using the high performance filter, install it in the filter frame without using the filter stopper.
--	---	-----------------	---

## 3. Specifications

Model	Power supply		Notch	Power consumption (W)	Air volume (m <sup>3</sup> /h)	Temperature exchange efficiency (%)	Sound level (dB)	Weight (kg)
	Frequency (Hz)	Voltage (V)						
VL-100U <sub>5</sub> -E VL-100EU <sub>5</sub> -E	50	220	Hi	30	100	73	36.5	7.5
			Lo	13	55	80	24	
		230	Hi	31	105	73	37	
			Lo	15	60	80	25	
		240	Hi	34	106	72	38	
			Lo	17	61	79	27	
	60	220	Hi	34	103	73	38	
			Lo	17	57	80	25	

\* The testing methods are based on Japanese Industrial Standard B 8628.

# 4. Outside dimensions

VL-100U5-E

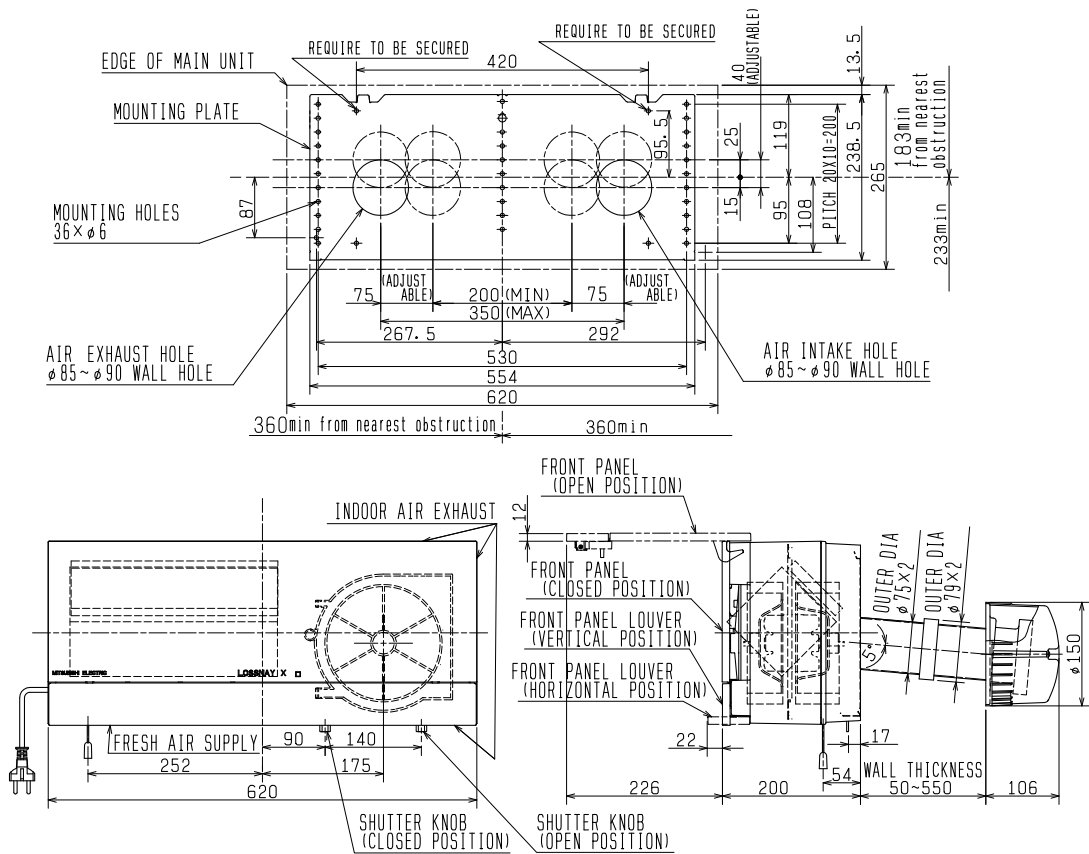

Unit (mm)

VL-100EU5-E

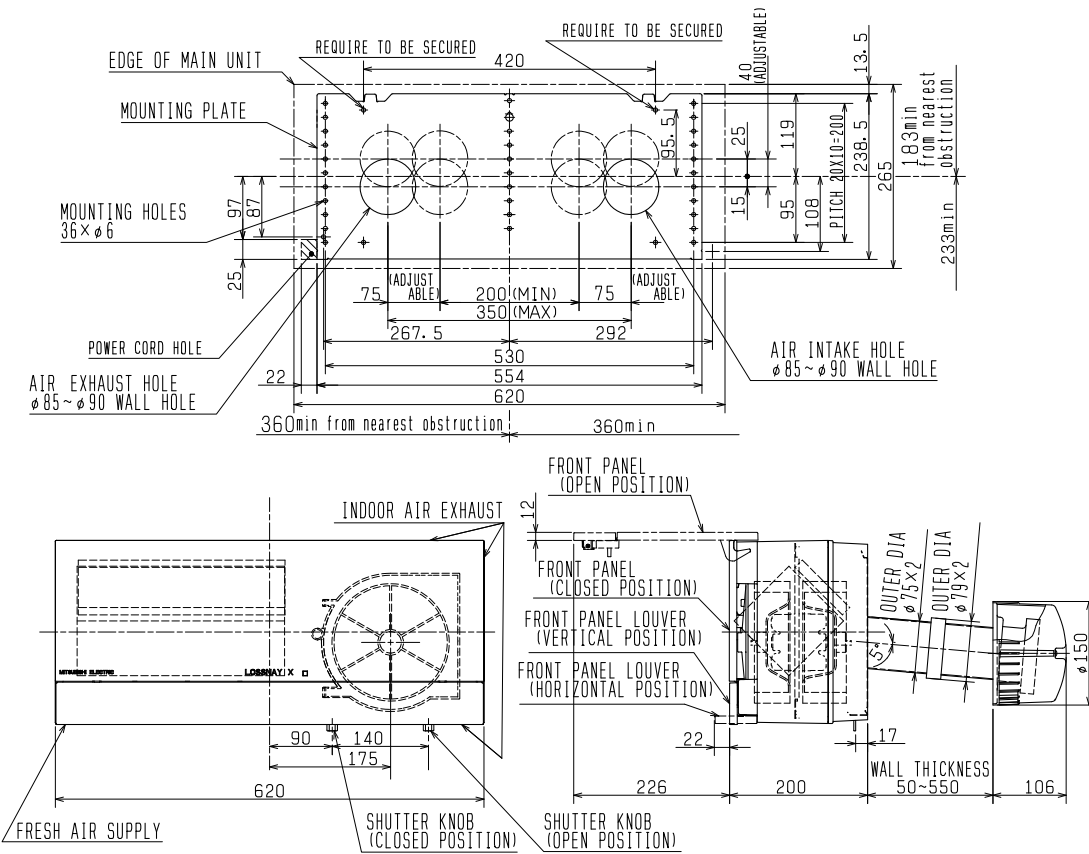

Unit (mm)

# 5. Electrical wiring diagrams

VL-100U<sub>5</sub>-E

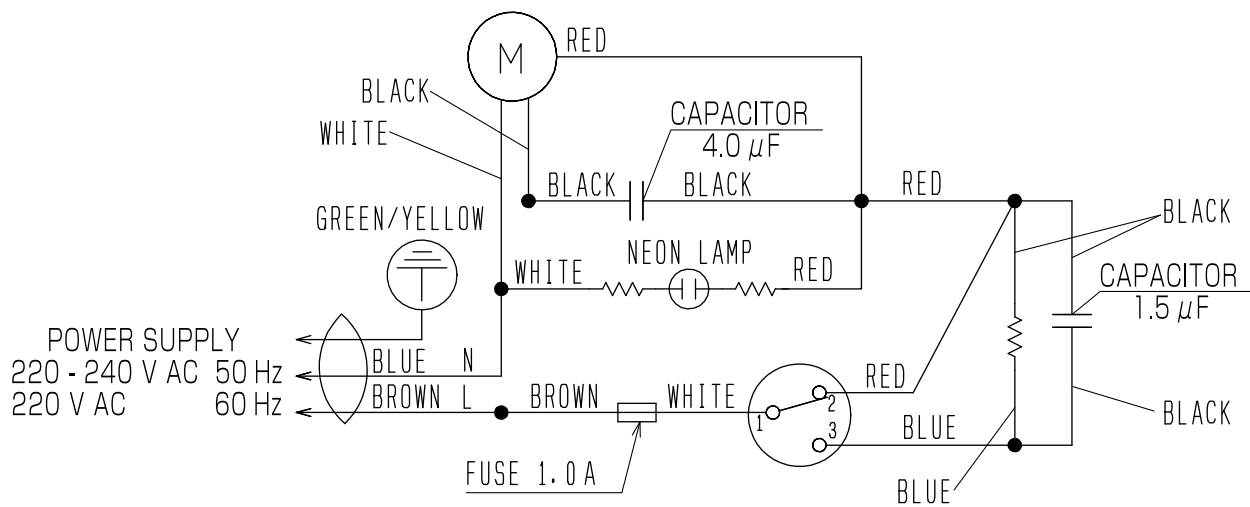

VL-100EU<sub>5</sub>-E

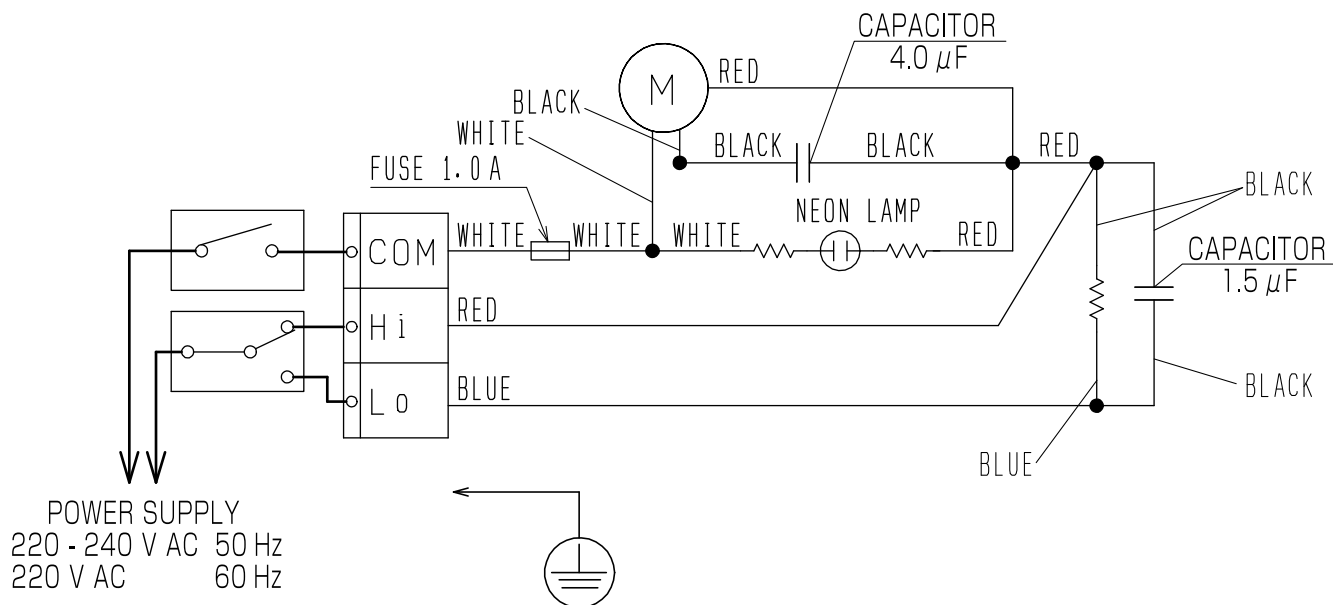

# 6. Troubleshooting

## ■ Work precautions

- When servicing, be sure to recreate the malfunction two or three times before starting repairs.
- When servicing, always keep proper footing.
- When servicing, always unplug the power cord from the outlet, or turn off the circuit breaker. Sufficient care must be taken to avoid electric shock or injury.
- Always connect the power wires properly.

## (1) Service Flowchart

After checking the check items below, follow the troubleshooting 1 and 2 for servicing.

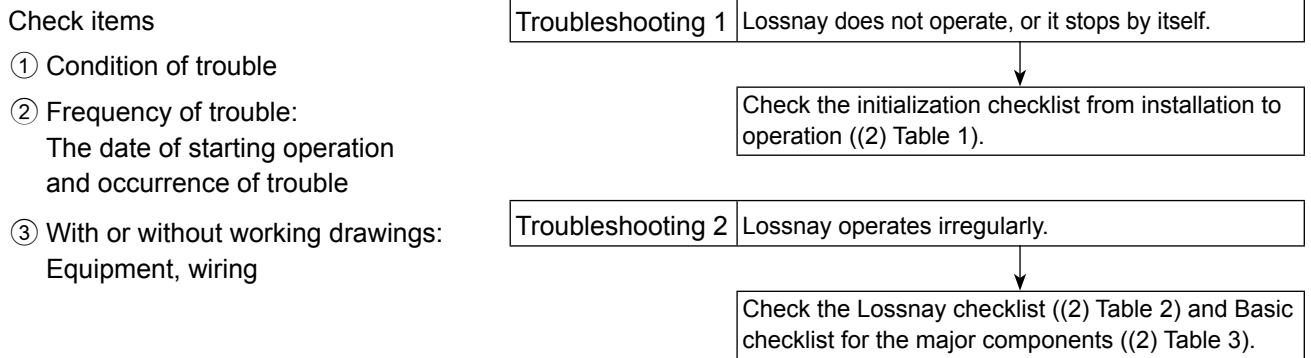

## (2) Checklist

Troubleshooting 1	Lossnay does not operate, or it stops by itself.
-------------------	--

### ① Initialization checklist from installation to operation (Table 1)

No.	Error	Checkpoint
1	The Lossnay operation is disabled or improper. Lossnay stops irregularly.	Check the main power connection. <For VL-100U5-E> • Is the power plug connected to the power supply of rated voltage? <For VL-100EU5-E> • Is the rated voltage supplied to the terminal block? • Is there a poor connection?

Troubleshooting 2	Lossnay operates irregularly.
-------------------	-------------------------------

### ② Lossnay checklist (Table 2)

No.	Error	Cause	Action
1	The shutter does not open. The shutter does not close.	Is there any foreign matter or obstruction around the shutter?	Remove it.
2	The fan does not rotate.	Do the fan blades touch other parts?	Check for an abnormal area. Replace the parts of the abnormal area.
		Is there any foreign matter around the fan?	Remove it.
		Is there something wrong with the motor?	Check the basic checklist for the major components (Table 3).
3	An unusual noise comes from the fan.	Is there any foreign matter around the fan?	Check around the fan.
		Can you rotate the fan manually?	No: Replace the motor.
		Is there an odd feeling when rotating the fan?	Yes: Replace the motor.

No.	Error	Cause	Action
3	An unusual noise comes from the fan.	Is there something wrong with the motor?	Check the basic checklist for the major components (Table 3). Replace the abnormal parts.
4	High/Low lamp does not illuminate.	Is Lossnay operating at the High or Low fan speed?	If the lamp does not illuminate during the High or Low fan speed operation, replace the neon lamp.

③ Basic checklist for the major components (Table 3)

\*Make sure to unplug the power cord or turn off the circuit breaker, before performing the procedures No. 2 to 4.

No.	Parts	Judging instructions								
1	—	Check that the fan rotates while the rated voltage is supplied.								
2	Fuse	Check if the fuse is blown out. If the fuse is blown out, replace the fuse.								
3	Switch with a pull cord (VL-100U <sub>5</sub> -E only)	Remove the switch from the main unit. Measure the resistance at the weld for the wire connection on the backside of the switch. If the resistance differs from the value listed below, replace the switch. <table border="1" style="margin-left: auto; margin-right: auto;"> <thead> <tr> <th>Color of wires</th> <th>Notch</th> <th>Resistance</th> </tr> </thead> <tbody> <tr> <td>White - Red</td> <td>High</td> <td rowspan="2">Approx. 0.1 Ω (conducted)</td> </tr> <tr> <td>White - Blue</td> <td>Low</td> </tr> </tbody> </table>	Color of wires	Notch	Resistance	White - Red	High	Approx. 0.1 Ω (conducted)	White - Blue	Low
Color of wires	Notch	Resistance								
White - Red	High	Approx. 0.1 Ω (conducted)								
White - Blue	Low									
4	Motor	<For VL-100U <sub>5</sub> -E> Measure the resistance between the pins of the power plug. <For VL-100EU <sub>5</sub> -E> Measure the resistance between C and Hi (High), and between C and Lo (Low) terminals of the terminal block. <ul style="list-style-type: none"> <li>• If the resistance differs from the value listed below, replace the motor and capacitors.</li> <li>• If the resistance is approximately equal to the value listed below, replace the capacitors.</li> </ul> <table border="1" style="margin-left: auto; margin-right: auto;"> <thead> <tr> <th>Notch</th> <th>Resistance</th> </tr> </thead> <tbody> <tr> <td>High</td> <td>Approx. 490 Ω</td> </tr> <tr> <td>Low</td> <td>Approx. 0.1 Ω</td> </tr> <tr> <td>OFF (VL-100U<sub>5</sub>-E only)</td> <td>Open</td> </tr> </tbody> </table>	Notch	Resistance	High	Approx. 490 Ω	Low	Approx. 0.1 Ω	OFF (VL-100U <sub>5</sub> -E only)	Open
Notch	Resistance									
High	Approx. 490 Ω									
Low	Approx. 0.1 Ω									
OFF (VL-100U <sub>5</sub> -E only)	Open									



## 7. How to call

Symptom	Remedy
The incoming air feels cold.	① Stop the operation, and close the shutter. ② Adjust the louver in a horizontal position. ③ Change the fan speed to Low.
Unusual noise occurs. (Noise became louder.)	① Clean the filters. ② Securely attach the front panel and filters.
Small insects intrude into the unit.	① Place the filter (outside air filter) properly inside the filter frame. ② Replace the filter (outside air filter) with the high performance filter (optional parts).

## 8. Service inspection list

Location	Inspection Item	Check Result
Electric wiring	Are the power lead wires securely connected to the terminal block? (VL-100EU5-E)	
	Is the wiring correct? (VL-100EU5-E)	
Appliance	Is the main unit securely mounted?	
	Does Lossnay operate as described in the Operating Instructions when operating the switch?	
	Is the fan operating?	
	Does the shutter work?	
	Does Lossnay operate without abnormal vibration or noise?	

# 9. Overhauling procedures

## ■ Work precautions

- Before replacing parts, follow the instructions described in the troubleshooting.
- When servicing, always keep proper footing.
- When servicing, always unplug the power cord from the outlet, or turn off the circuit breaker. Sufficient care must be taken to avoid electric shock or injury.
- Always connect the power wires properly.
- After completing repairs, verify that the product operates properly.
- Always wear gloves when servicing.

### (1) Turning power off

- ① Stop the operation by the switch.
- ② Unplug the power cord from the outlet, or turn off the circuit breaker.

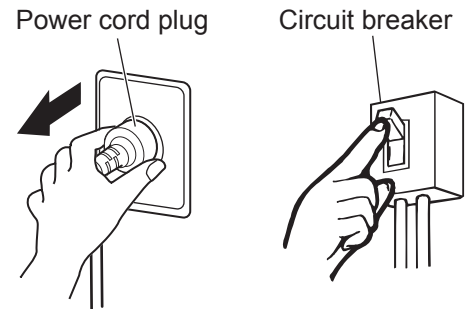

### (2) Power lead wires to the terminal block

For VL-100EU5-E

- ① Open the front panel.

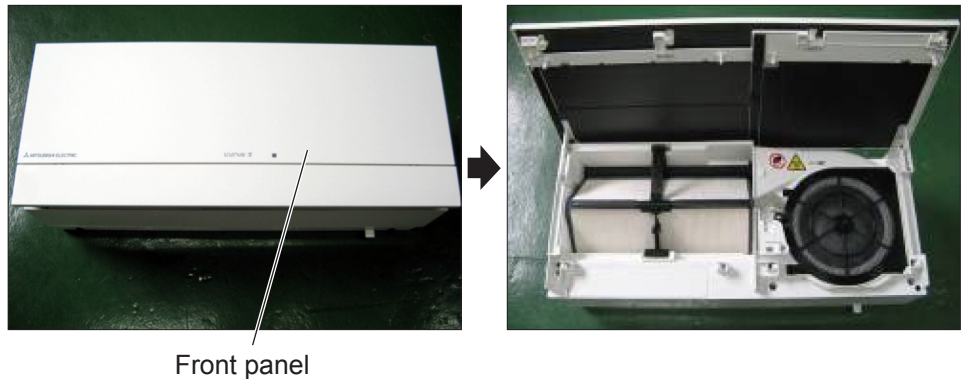

Front panel

- ② Unhook the claw of the cover, and remove the cover.

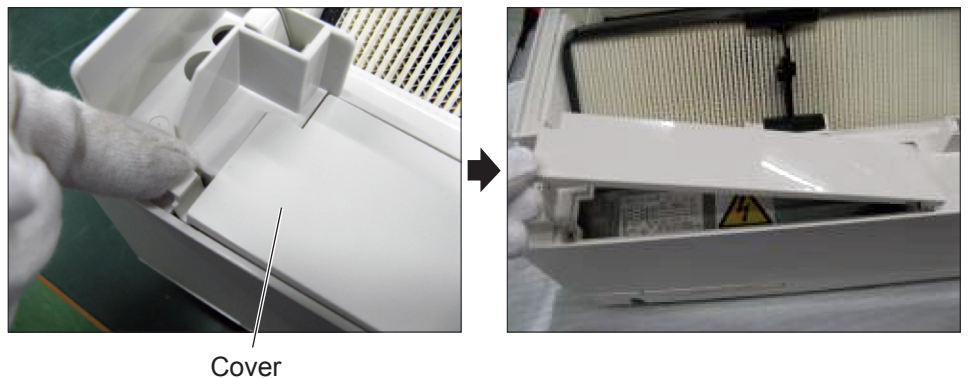

Cover

- ③ Unscrew the terminal block (TB) case cover clamping screw (one PT screw 4 × 8, indicated by ○), and remove the TB case cover.

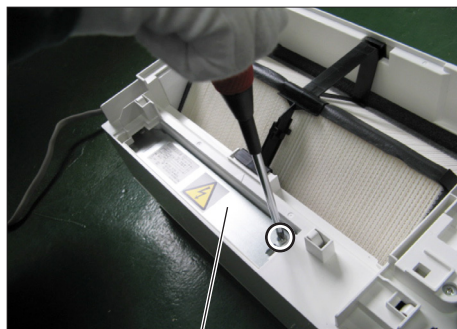

TB case cover

- ④ Loosen the screws of the terminal block (three screws, indicated by ○) with a screwdriver, and disconnect the power lead wires.

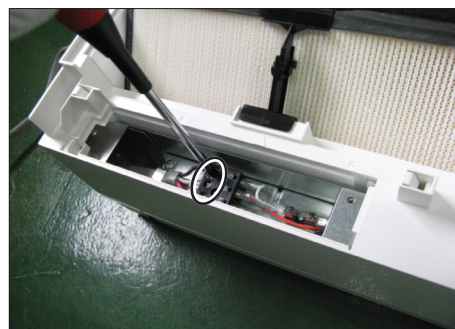

### (3) Main unit

- ① Unscrew the main unit clamping screws (two black PTT screws 4 × 8, indicated by ○).
- ② Slightly lift the main unit, and then take it down.

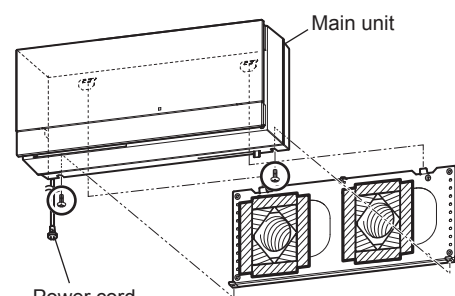

\*The illustration shows VL-100U5-E.

### (4) Front panel

- Open the front panel all the way (approx. 90 degrees), and pull it up to unhook the claws (indicated by ○).

**Precaution**

Pay attention not to damage the front surface of the removed panel.

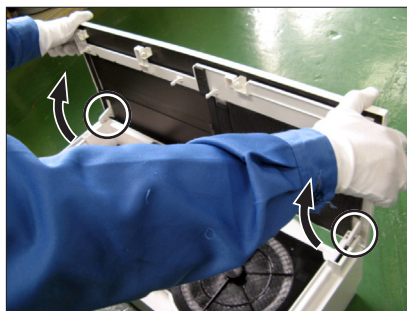
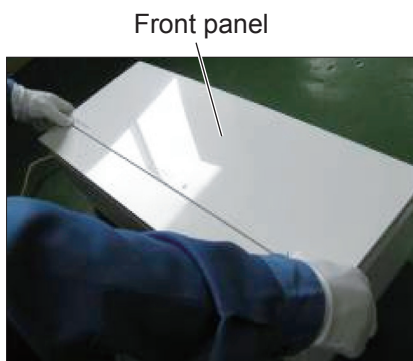

## (5) Lossnay core

- Hold the core handle, and pull it out in the direction of the arrow while holding down the hook part.

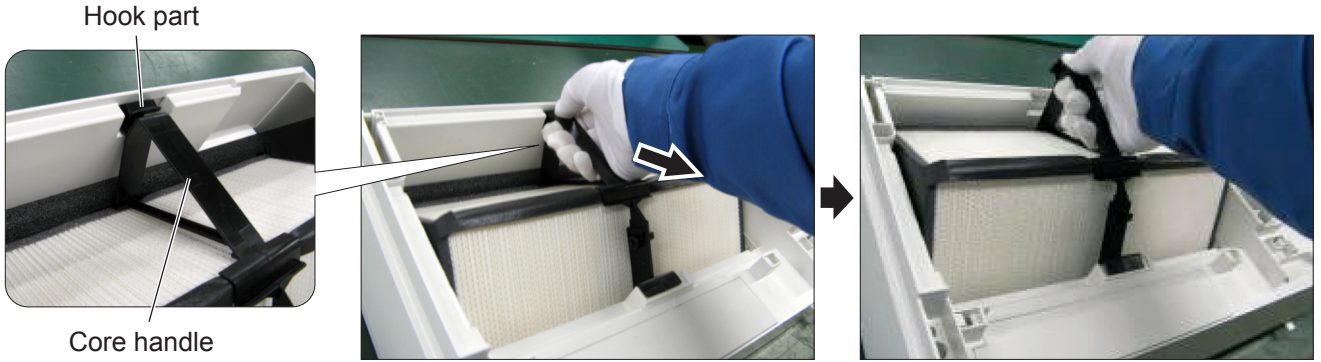

### <Reassembly procedure>

- When installing the Lossnay core, first fit the lower part of the core handle (indicated by "a") into "b" position of the front casing, and then hook the ledge of the core handle to the concave portion of the front casing (indicated by □).

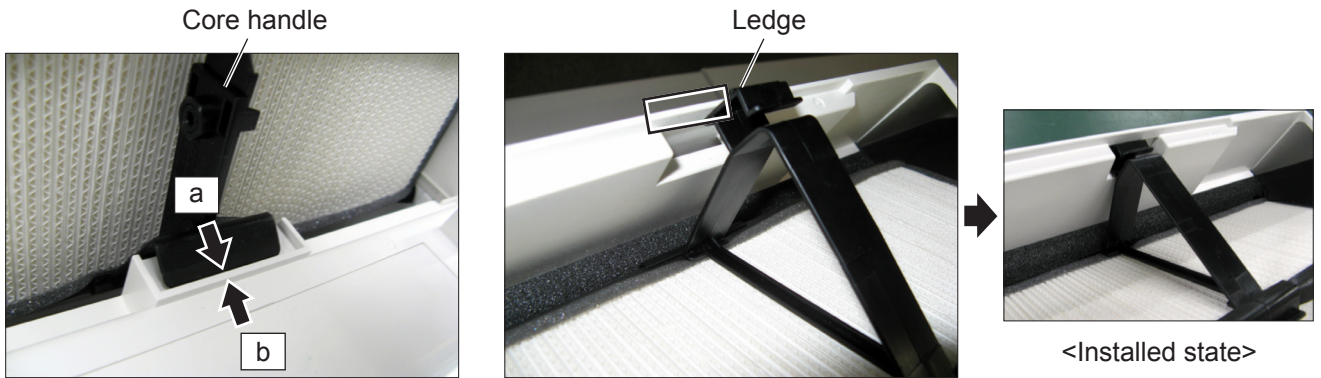

**Reassembly precaution**  
Check that both edges of the Lossnay core (indicated by ○) are securely fitted.



## (6) Front casing

- ① Unscrew the screws (six PTT screws 4 × 14, indicated by ○).

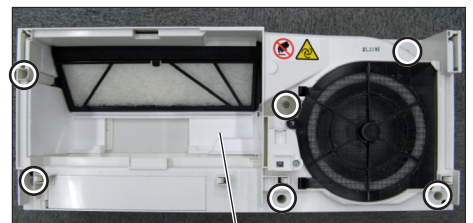

Front casing

- ② Unscrew the lamp cover clamping screw (one PTT screw 4 × 14, indicated by ○), and remove the lamp cover.

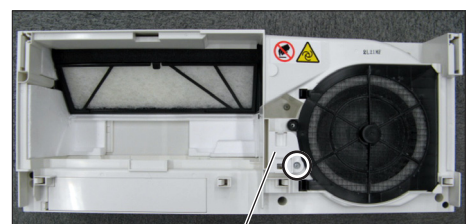

Lamp cover

③ Remove the neon lamp from the front casing.

④ Pass the neon lamp through the hole of the front casing, and then remove the front casing.



Neon lamp      Hole of the front casing

## (7) Air exhaust (EA) fan

① Remove the special nut (8) and tab washer, and then remove the EA fan.

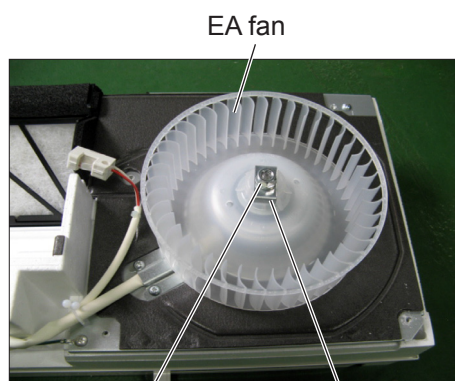

EA fan  
Special nut (8)      Tab washer

② Remove the special (spl) washer (40 mm in outer diameter).

**Reassembly precaution**  
Be aware of the size difference between each washer for EA fan and SA fan.  
Incorrect installation may cause unusual noise.

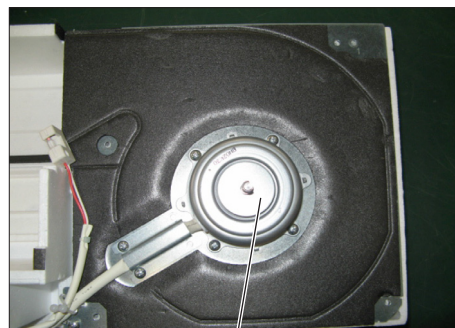

Spl washer

## (8) Air supply (SA) fan

- ① Unscrew the motor fix plate clamping screw (one PTT screw 4 × 14, indicated by ○).

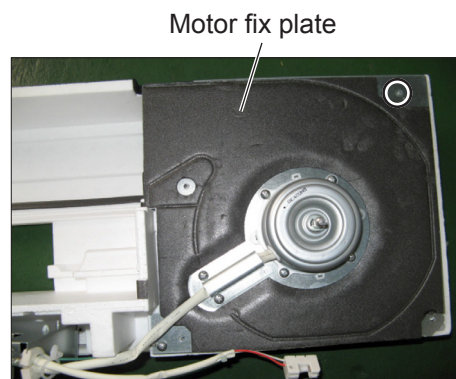

- ② Turn the motor fix plate upside down, and put it on the main unit.
- ③ Remove the special nut (8) and tab washer, and then remove the SA fan.

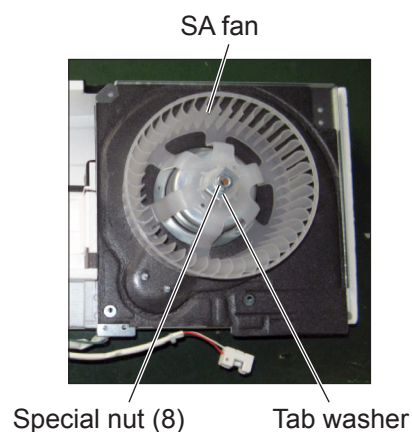

- ④ Remove the special (spl) washer (8) (16 mm in outer diameter).

### Reassembly precaution

Be aware of the size difference between each washer for EA fan and SA fan.

Incorrect installation may cause unusual noise.

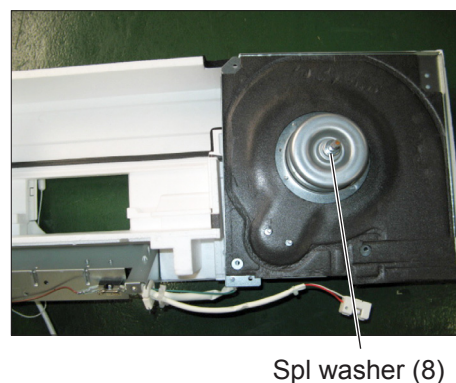

## (9) Motor

- Unscrew the screws that clamps motor and lead cover (six PTT screws 4 × 10, indicated by ○), and then remove the motor.

### Reassembly precaution

When installing the lead cover, make sure to place it under the motor (indicated by □).

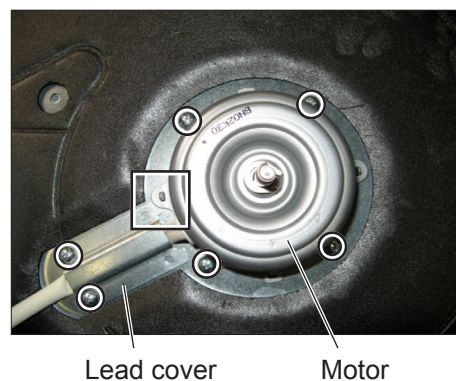

## (10) Terminal block case (TB case)

- ① Unscrew the TB case clamping screw (one PT screw 4 × 8, indicated by ○), and remove the TB case.

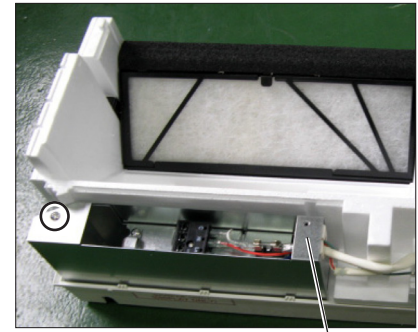

TB case

- ② Unscrew the TB fix plate clamping screws (two PTT screws 4 × 8, indicated by ○), and remove the TB fix plate.

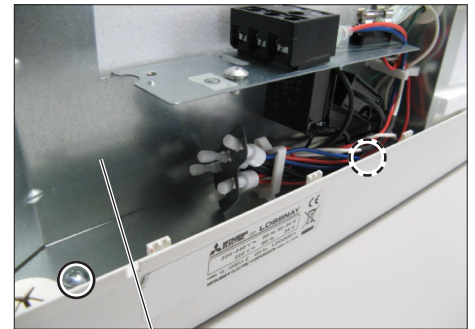

TB fix plate

## (11) Fan casing

- Remove the fan casing (made of styrene foam).

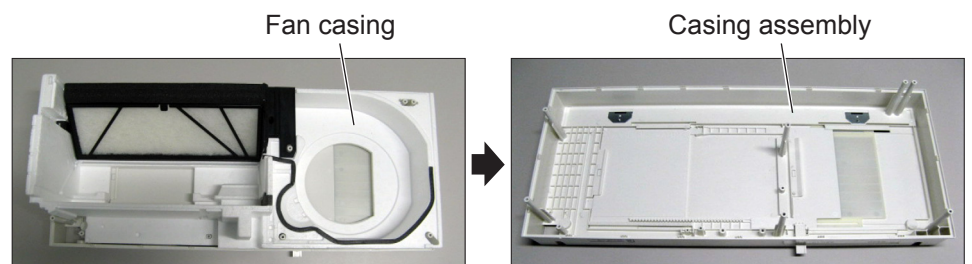

## \* When reassembling

- Reassemble the unit in the reverse order of disassembly.
- After reassembly, always make a test run to make sure that the unit operates properly.

# 10. Parts catalog

## Please note the following when using the parts catalog.

1. When ordering parts, always indicate the part number, part name, and the number of parts required.
2. It may take time for you to receive the parts. Make an inquiry about a rush order.
3. Specifications may be subject to change without notice.
4. Parts marked with  $\triangle$  and      are critical for safety.
5. To maintain safety and performance, always replace the parts with the parts prescribed.
6. When replacing the parts to which the nameplate is attached, remove the nameplate and attach it to the new parts.

### Description of screw abbreviations

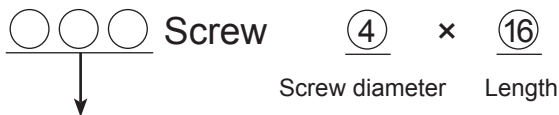

Abbreviation	Description
PC screw	Cross recess flat head machine screw
PRC screw	Cross recess oval head machine screw
PP screw	Cross recess pan head machine screw
SW · PP screw	Cross recess pan head screw with spring washer
PPT screw	Cross recess tapping screw
PCT screw	Cross recess flat head tapping screw
PTT screw	Cross recess truss head tapping screw
PT screw	Cross recess truss head machine screw
SET screw	Slotted head stop screw
SQ · SET screw	Square head stop screw
P · SET screw	Pan head stop screw
PMT screw	Primer truss head screw
HS · SET screw	Hexagon head stop screw
P · R · W screw	Cross recess round wood screw
P · C · W screw	Cross recess flat head wood screw
P · R · C · W screw	Cross recess round and flat wood screw
R · W screw	Slotted round wood screw
PW · PP screw	Cross recess pan head screw with small washer
SW-PW · PP screw	Cross recess pan head machine screw with spring washer and flat washer



# VL-100U5-E

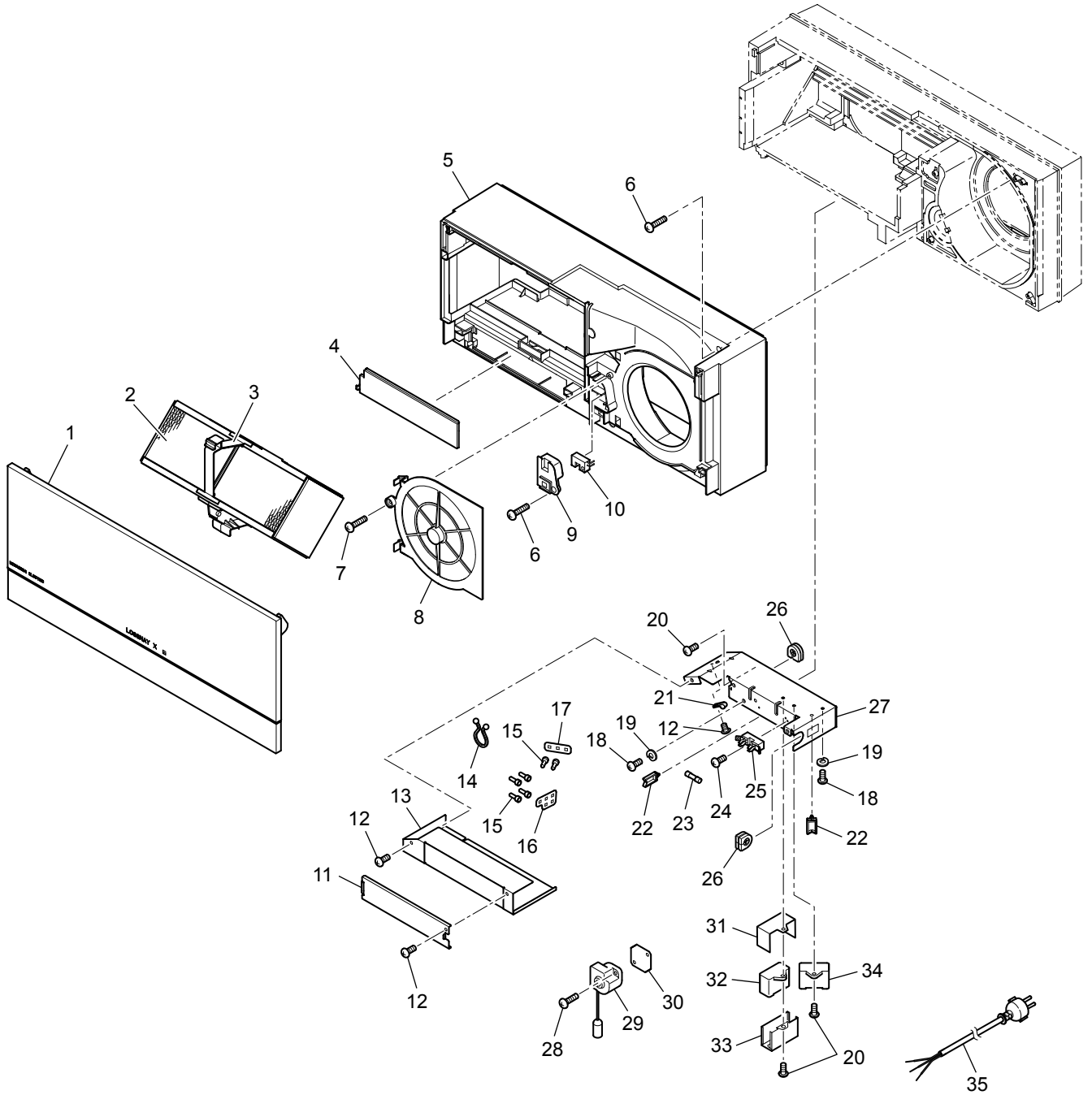

## VL-100U5-E

No.	Name of part	Parts No.	Q'ty pcs/unit	Critical for safety	Remarks
1	Front panel	W36 001 719	1		
2	Lossnay core	W36 001 710	1	⚠	
3	Core handle	W36 001 706	1		
4	Cover	W36 001 707	1		
5	Front casing	W36 001 729	1		
6	PTT screw 4x14	W00 000 040	8		
7	PTT screw 4x10	W00 000 039	1		
8	Filter	W36 001 717	1	⚠	
9	Lamp cover	W36 001 708	1		
10	Neon lamp	W36 001 290	1	⚠	
11	TB case cover	W36 001 709	1		
12	PT screw 4x8	W00 000 050	3		
13	TB case	W36 001 711	1		
14	Cord band	W00 000 231	1		White
15	Crimp cap	W82 003 240	6	⚠	CE1 (CE-100V)
16	Cord clamber	W36 001 223	1		5P
17	Cord clamber	W36 001 224	1		3P
18	PT screw 4x8 BS	W00 000 011	3		
19	Spring washer (4)	W00 000 077	3		
20	PTT screw 4x8	W00 000 009	6		
21	Cord clip	W00 000 260	1		
22	Cord clip	W00 000 250	2		
23	Fuse	W36 001 280	1	⚠	1A · 250V
24	PPT screw 3x10	W00 000 027	1		
25	Fuse holder	W50 004 282	1		
26	Cord bush	W00 000 225	2		
27	TB fix plate	W36 001 712	1		
28	PPT screw 4x10	W00 000 031	1		
29	Switch	W36 001 255	1	⚠	With a pull cord
30	Insulation plate	W36 001 201	1	⚠	
31	Capacitor case	W82 003 653	1		
32	Capacitor	W36 001 283	1	⚠	4.0μF · 250VAC
33	Capacitor cover	W82 003 652	1		
34	Capacitor	W36 001 284	1	⚠	1.5μF · 250VAC
35	Power cord	W36 001 220	1	⚠	3200mm

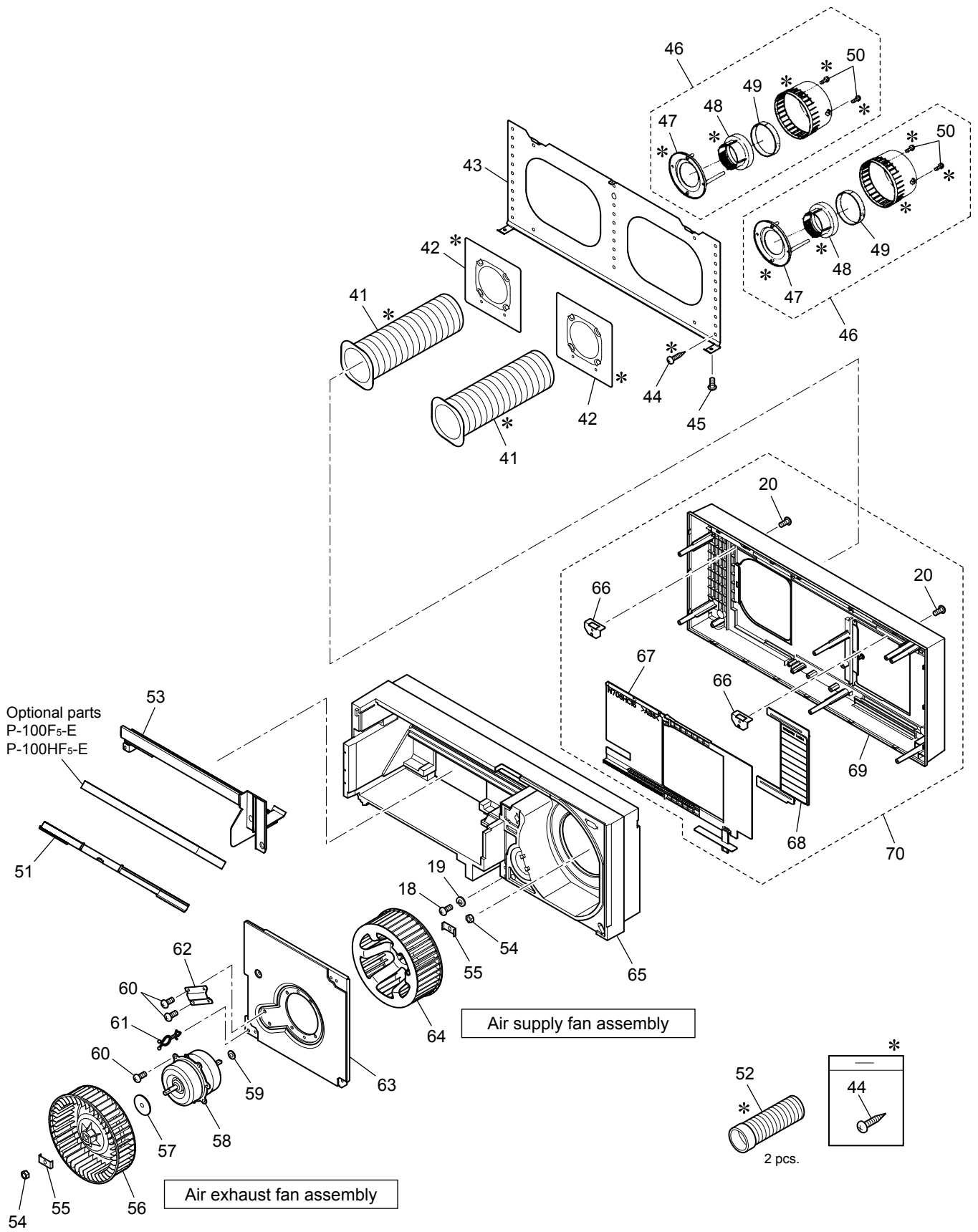

## VL-100U5-E

No.	Name of part	Parts No.	Q'ty pcs/unit	Critical for safety	Remarks
41	Wall pipe	W36 001 731	2		
42	Pipe fix plate	W36 001 713	2		
43	Fix plate	W36 001 714	1		
44	Spl screw 3.5x35	W00 000 048	9		
45	PTT screw 4x8	W00 000 036	2		Black
46	Weather cover	W36 001 720	2		
47	Flange	W36 001 715	2		
48	Flange nut	W36 001 303	2		
49	Packing	W36 001 718	2		
50	PTT screw 4x12 (SUS)	W00 000 010	4		
51	Filter stopper	W36 001 716	1		
52	Pipe	W36 001 721	2		
53	Filter frame	W36 001 722	1		
54	Special nut (M8)	W00 000 069	2		
55	Tab washer	W00 000 079	2		
56	Centrifugal fan	W36 001 480	1	⚠	φ 170
57	Special washer (8)	W00 000 156	1		φ 40 (Outer dia.)
58	Motor	W36 001 453	1	⚠	
59	Special washer (8)	W00 000 148	1		φ 16 (Outer dia.)
60	PTT screw 4x10	W00 000 037	6		
61	Cord clamber	W00 000 255	1		
62	Lead cover	W36 001 704	1		
63	Motor fix plate	W36 001 723	1		
64	Centrifugal fan	W36 001 481	1	⚠	φ 170
65	Fan casing	W36 001 724	1		
66	Mounting piece	W36 001 345	2		
67	Shutter	W36 001 725	1		
68	Shutter	W36 001 726	1		
69	Casing	W36 001 727	1		
70	Casing assembly	W36 001 728	1		With shutters

# VL-100EU5-E

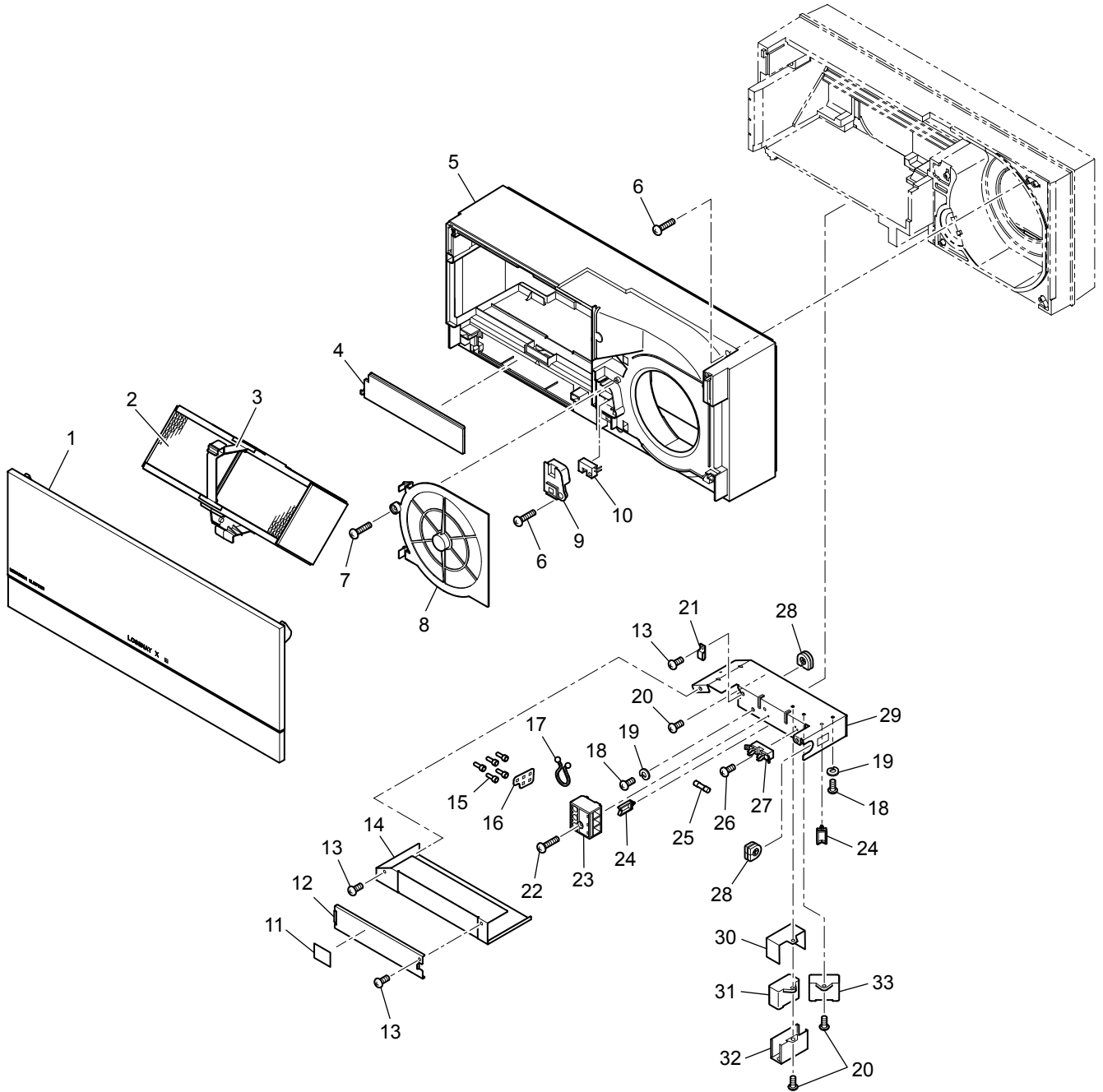

## VL-100EU5-E

No.	Name of part	Parts No.	Q'ty pcs/unit	Critical for safety	Remarks
1	Front panel	W36 001 719	1		
2	Lossnay core	W36 001 710	1	⚠	
3	Core handle	W36 001 706	1		
4	Cover	W36 001 707	1		
5	Front casing	W36 001 729	1		
6	PTT screw 4x14	W00 000 040	8		
7	PTT screw 4x10	W00 000 039	1		
8	Filter	W36 001 717	1	⚠	
9	Lamp cover	W36 001 708	1		
10	Neon lamp	W36 001 290	1	⚠	
11	Wiring diagram	W36 001 357	1		
12	TB case cover	W36 001 709	1		
13	PT screw 4x8	W00 000 050	3		
14	TB case	W36 001 730	1		
15	Crimp cap	W82 003 240	5	⚠	CE1 (CE-100V)
16	Cord clamper	W36 001 223	1		5P
17	Cord band	W00 000 231	1		White
18	PT screw 4x8 BS	W00 000 011	3		
19	Spring washer (4)	W00 000 077	3		
20	PTT screw 4x8	W00 000 009	6		
21	Cord clip	W00 000 233	1		
22	PPT screw 3x20	W00 000 028	1		
23	Terminal block	W36 001 242	1	⚠	3P
24	Cord clip	W00 000 250	2		
25	Fuse	W36 001 280	1	⚠	1A·250V
26	PPT screw 3x10	W00 000 027	1		
27	Fuse holder	W50 004 282	1		
28	Cord bush	W00 000 225	2		
29	TB fix plate	W36 001 732	1		
30	Capacitor case	W82 003 653	1		
31	Capacitor	W36 001 283	1	⚠	4.0μF·250VAC
32	Capacitor cover	W82 003 652	1		
33	Capacitor	W36 001 284	1	⚠	1.5μF·250VAC

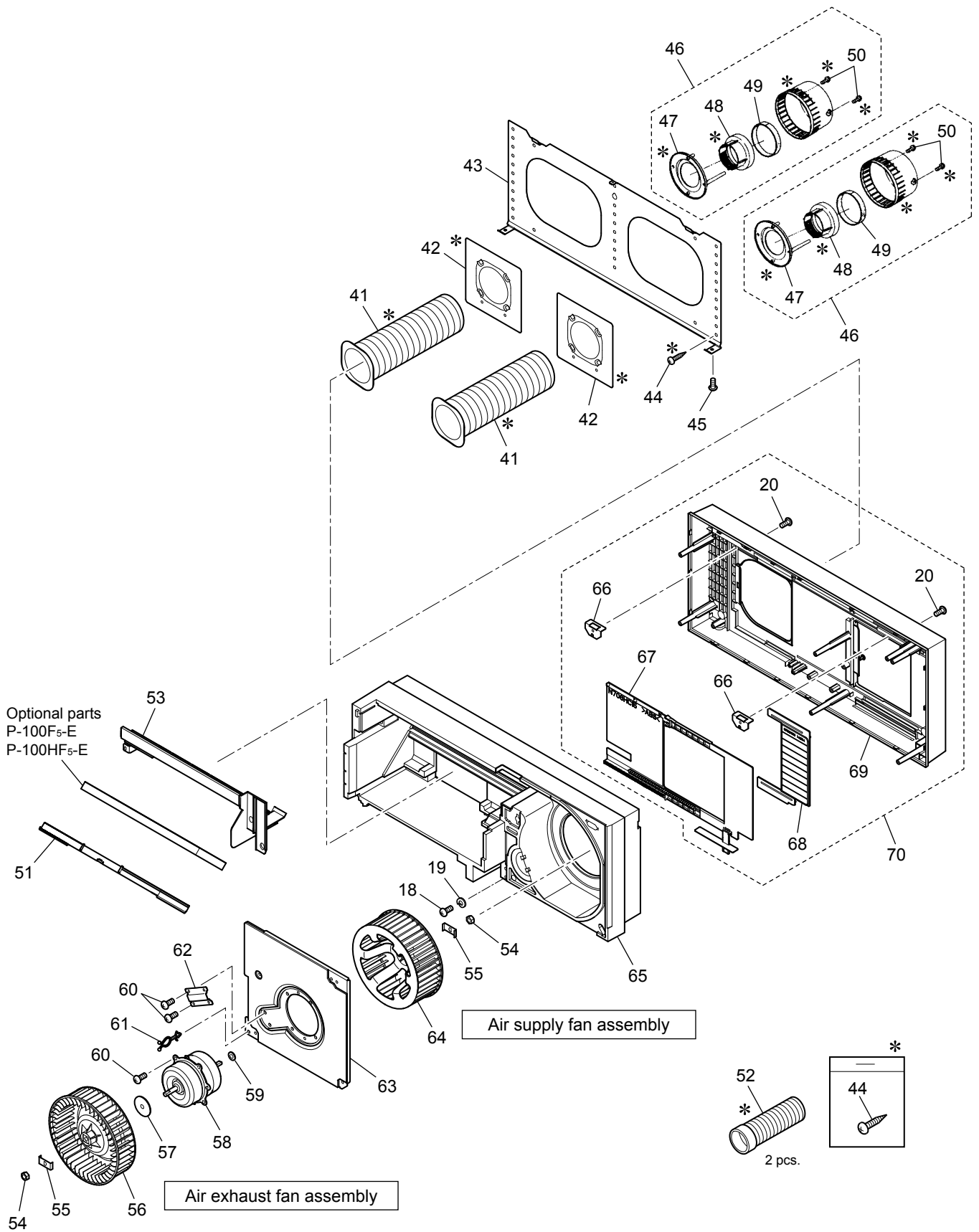

## VL-100EU5-E

No.	Name of part	Parts No.	Q'ty pcs/unit	Critical for safety	Remarks
41	Wall pipe	W36 001 731	2		
42	Pipe fix plate	W36 001 713	2		
43	Fix plate	W36 001 714	1		
44	Spl screw 3.5x35	W00 000 048	9		
45	PTT screw 4x8	W00 000 036	2		Black
46	Weather cover	W36 001 720	2		
47	Flange	W36 001 715	2		
48	Flange nut	W36 001 303	2		
49	Packing	W36 001 718	2		
50	PTT screw 4x12 (SUS)	W00 000 010	4		
51	Filter stopper	W36 001 716	1		
52	Pipe	W36 001 721	2		
53	Filter frame	W36 001 722	1		
54	Special nut (M8)	W00 000 069	2		
55	Tab washer	W00 000 079	2		
56	Centrifugal fan	W36 001 480	1	⚠	φ 170
57	Special washer (8)	W00 000 156	1		φ 40 (outer dia.)
58	Motor	W36 001 453	1	⚠	
59	Special washer (8)	W00 000 148	1		φ16 (outer dia.)
60	PTT screw 4x10	W00 000 037	6		
61	Cord clamber	W00 000 255	1		
62	Lead cover	W36 001 704	1		
63	Motor fix plate	W36 001 723	1		
64	Centrifugal fan	W36 001 481	1	⚠	φ 170
65	Fan casing	W36 001 724	1		
66	Mounting piece	W36 001 345	2		
67	Shutter	W36 001 725	1		
68	Shutter	W36 001 726	1		
69	Casing	W36 001 727	1		
70	Casing assembly	W36 001 728	1		With shutters