



SPLIT-TYPE, HEAT PUMP AIR CONDITIONERS

2001

# TECHNICAL & SERVICE MANUAL

## Series PEHD/PEAD Ceiling Concealed R407C

<indoor unit> Service ref.

Models	PEHD-P1.6EAH	PEAD-P1.6EA
	PEHD-P2EAH	PEAD-P2EA
	PEHD-P2.5EAH	PEAD-P2.5EA
	PEHD-P3EAH	PEAD-P3EA
	PEHD-P4EAH	PEAD-P4EA
	PEHD-P5EAH	PEAD-P5EA
	PEHD-P6EAH	PEAD-P6EA

This manual does not cover the following outdoor units. When servicing them, please refer to the service manual No.OC180 REVISED EDITION-A and this manual as a set.

PUH-P1.6VGA	PU-P1.6VGA
PUH-P1.6YGA	PUH-P2VGA
PU-P2VGA	PUH-P2YGA
PUH-P2.5VGA <sub>1</sub>	PU-P2.5VGA <sub>1</sub>
PUH-P2.5YGA <sub>1</sub>	
PUH-P3VGA	PU-P3VGA
PUH-P3YGA	PU-P3YGA
PUH-P4YGA	PU-P4YGA
PUH-P5YGA	PU-P5YGA
PUH-P6YGA	PU-P6YGA

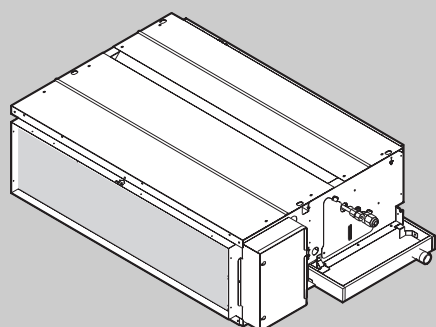

INDOOR UNIT

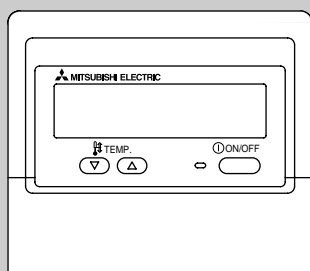

REMOTE CONTROLLER

### CONTENTS

1. COMBINATION OF INDOOR AND OUTDOOR UNITS .....	1
2. SAFETY PRECAUTION .....	2
3. PART NAMES AND FUNCTIONS .....	4
4. SPECIFICATION .....	7
5. DATA .....	15
6. REFRIGERANT SYSTEM DIAGRAM .....	36
7. OUTLINES & DIMENSIONS .....	37
8. WIRING DIAGRAM .....	39
9. DISASSEMBLY INSTRUCTIONS .....	40
10. PARTS LIST .....	42
11. OPTIONAL PARTS .....	49



# 1

# COMBINATION OF INDOOR AND OUTDOOR UNITS

	Indoor unit	Outdoor unit								
		Heat pump type						Cooling only type		
		PUH-P · VGA / YGA						PU-P · VGA / YGA		
		1.6VGA	1.6YGA	2VGA	2YGA	2.5VGA <sub>1</sub>	2.5YGA <sub>1</sub>	1.6VGA	2VGA	2.5VGA <sub>1</sub>
Heat pump with electric heater	PEHD-P1.6EAH	○	○	—	—	—	—	—	—	—
	PEHD-P2EAH	—	—	○	○	—	—	—	—	—
	PEHD-P2.5EAH	—	—	—	—	○	○	—	—	—
Heat pump without electric heater or Cooling only	PEAD-P1.6EA	○	○	—	—	—	—	○	—	—
	PEAD-P2EA	—	—	○	○	—	—	—	○	—
	PEAD-P2.5EA	—	—	—	—	○	○	—	—	○

	Indoor unit	Outdoor unit									
		Heat pump type						Cooling only type			
		PUH-P · VGA / YGA						PU-P · VGA / YGA			
		3VGA	3YGA	4YGA	5YGA	6YGA	3VGA	3YGA	4YGA	5YGA	6YGA
Heat pump with electric heater	PEHD-P3EAH	○	○	—	—	—	—	—	—	—	—
	PEHD-P4EAH	—	—	○	—	—	—	—	—	—	—
	PEHD-P5EAH	—	—	—	○	—	—	—	—	—	—
	PEHD-P6EAH	—	—	—	—	○	—	—	—	—	—
Heat pump without electric heater or Cooling only	PEAD-P3EA	○	○	—	—	—	○	○	—	—	—
	PEAD-P4EA	—	—	○	—	—	—	—	○	—	—
	PEAD-P5EA	—	—	—	○	—	—	—	—	○	—
	PEAD-P6EA	—	—	—	—	○	—	—	—	—	○

**Cautions for using with the outdoor unit which adopts R407C refrigerant.**

- **Do not use the existing refrigerant piping.**
    - The old refrigerant and refrigerant oil in the existing piping contains a large amount of chlorine which may cause the refrigerant oil of the new unit to deteriorate.
  - **Do not use copper pipes which are broken, deformed or discolour.**

In addition, be sure that the inner surfaces of the pipes are clean, free of hazardous sulphur and oxides, or have no dust / dirt, shaving particles, oils, moisture or any other contamination.

    - If there is a large amount of residual oil (hydraulic oil, etc.) inside the piping and joints, deterioration of the refrigerant oil will result.
  - **Store the piping to be used during installation indoors and keep both ends of the piping sealed until just before brazing. (Store elbows and other joints in a plastic bag.)**
    - If dust, dirt, or water enters the refrigerant cycle, deterioration of the oil and compressor trouble may result.
  - **Use ester oil, ether oil or alkyl benzene (small amount) as the refrigerant oil to coat flares and flange connections.**
    - The refrigerant oil will degrade if it is mixed with a large amount of mineral oil.
- Use liquid refrigerant to fill the system.**
- If gas refrigerant is used to fill the system, the composition of the refrigerant in the cylinder will change and performance may drop.
- **Do not use a refrigerant other than R407C.**
    - If another refrigerant (R22, etc.) is used, the chlorine in the refrigerant may cause the refrigerant oil to deteriorate.
  - **Use a vacuum pump with a reverse flow check valve.**
    - The vacuum pump oil may flow back into the refrigerant cycle and cause the refrigerant oil to deteriorate.
  - **Do not use the following tools that are used with conventional refrigerant.**

(Gauge manifold , charge hose, gas leak detector, reverse flow check valve, refrigerant charge base, vacuum gauge, refrigerant recovery equipment)

    - If the conventional refrigerant and refrigerant oil are mixed in the R407C, the refrigerant may deteriorate.
    - If water is mixed in the R407C, the refrigerant oil may deteriorate.
    - Since R407C does not contain any chlorine, gas leak detectors for conventional refrigerant will not react to it.
  - **Do not use a charging cylinder.**
    - Using a charging cylinder may cause the refrigerant to deteriorate.
  - **Be especially careful when managing the tools.**
    - If dust, dirt, or water gets in the refrigerant cycle, the refrigerant may deteriorate.
  - **Do not use the drier which is sold in the field.**
    - The drier for R407C refrigerant is per-attached to outdoor unit refrigerant circuit.
    - Some drier in the field are not in conformity with R407C refrigerant .

## [1] Service tools

Use the below service tools as exclusive tools for R407C refrigerant.

No.	Tool name	Specifications
①	Gauge manifold	· Only for R407C.
		· Use the existing fitting SPECIFICATIONS. (UNF7/16)
		· Use high-tension side pressure of 3.43MPa-G or over.
②	Charge hose	· Only for R407C.
		· Use pressure performance of 5.10MPa-G or over.
③	Electronic scale	
④	Gas leak detector	· Use the detector for R407C.
⑤	Adaptor for reverse flow check.	· Attach on vacuum pump.
⑥	Refrigerant charge base.	
⑦	Refrigerant cylinder.	· For R407C    · Top of cylinder (Brown)
		· Cylinder with syphon
⑧	Refrigerant recovery equipment.	

## [2] Notice on repair service

- After recovering all the refrigerant in the unit, repairs/servicing can proceed.
- Do not release refrigerant in the air.
- After completing the repair service, recharge the circuit with the specified amount of liquid refrigerant.

## [3] Refrigerant recharging

(1) Refrigerant recharging process

① Direct charging from the cylinder.

- R407C cylinder are available on the market with a syphon pipe.
- Leave the syphon pipe cylinder standing and recharge it. (By liquid refrigerant)

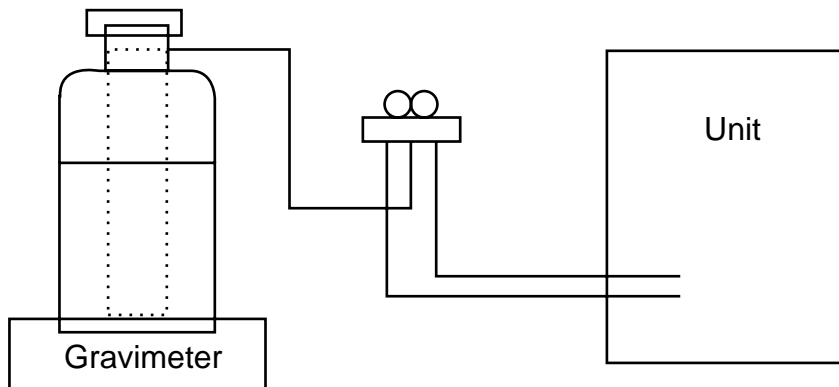

(2) Recharge in refrigerant leakage case

- After recovering all the refrigerant in the unit, repairs/servicing can proceed.
- Do not release the refrigerant in the air.
- After completing the repair service, recharge the circuit with the specified amount of liquid refrigerant.

# 3

# PART NAMES AND FUNCTIONS

## ● Indoor Unit

Air intake (sucks the air inside the room into the unit)

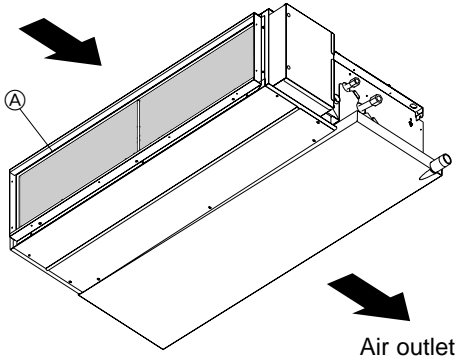

In case of rear inlet

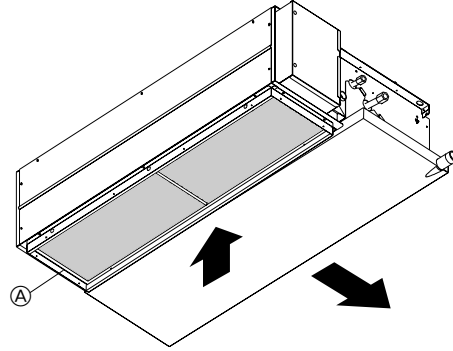

In case of bottom inlet  
(Only 1.6~2.5HP)

● Remote controller

- Once the operation of the unit is set, subsequent operations can be performed only by pressing the ON/OFF button repeatedly.

● Operation buttons

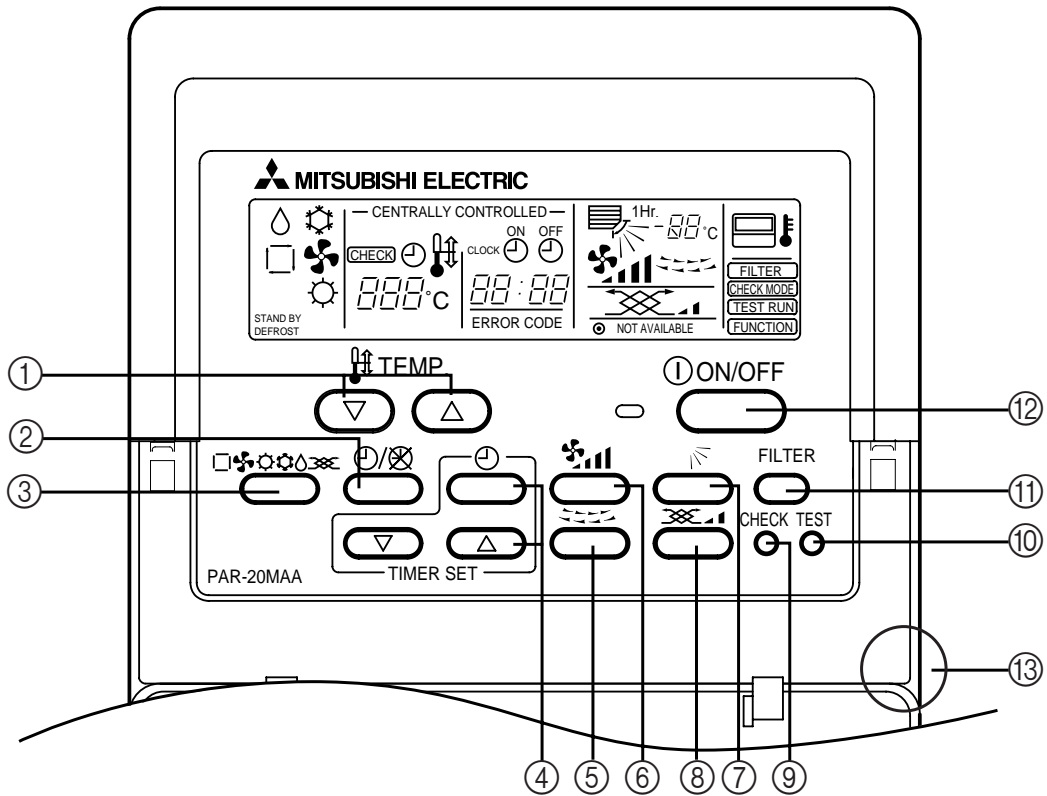

- ① [Room temperature adjustment] Button
- ② [Timer/continuous] Button
- ③ [Selecting operation] Button
- ④ [Time selection] Button  
[Time-setting] Button
- ⑤ [Louver] Button (This button does not operate in this model)
- ⑥ [Fan speed adjustment] Button
- ⑦ [Up/down airflow direction] Button (This button does not operate in this model)
- ⑧ [Ventilation] Button
- ⑨ [Checking/built-in] Button
- ⑩ [Test run] Button
- ⑪ [Filter] Button (This button does not operate in this model)
- ⑫ [ON/OFF] Button
- ⑬ Position of built-in room temperature

- Never expose the remote controller to direct sunlight. Doing so can result in the erroneous measurement of room temperature.
- Never place any obstacle around the lower right-hand section of the remote controller. Doing so can result in the erroneous measurement of room temperature.

## ● Display

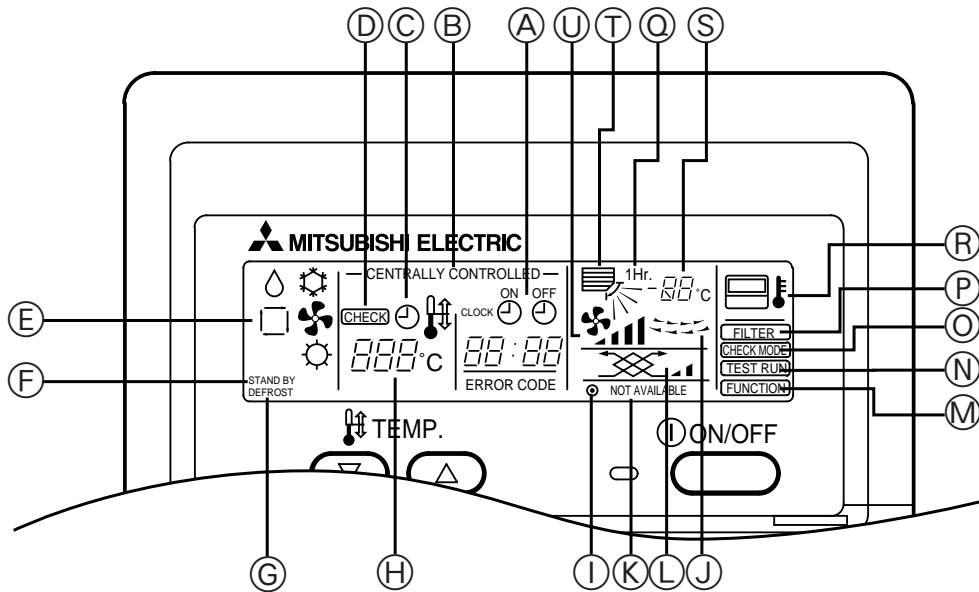

- |   |                             |
|---|-----------------------------|
| (A) Current time/Timer                              | (K) Not available function  |
| (B) Centralized control                             | (L) Ventilation             |
| (C) Timer ON  | (M) Function setting mode   |
| (D) Abnormality occurs                              | (N) Test run mode           |
| (E) Operation mode:  COOL,  DRY,  AUTO,  FAN,  HEAT | (O) Error check mode        |
| (F) Preparing for Heating mode                      | (P) Filter sign             |
| (G) Defrost mode                                    | (Q) Set effective for 1 hr. |
| (H) Set temperature                                 | (R) Sensor position         |
| (I) Power ON  | (S) Room temperature        |
| (J) Louver  | (T) Airflow                 |
|   | (U) Fan speed               |

### Caution

- Power ON display lights up when unit is in standby mode.
- When power is turned ON for the first time the (CENTRAL CTRL) display appears to go off momentarily but this is not a malfunction.
- When the central control remote control unit, which is sold separately, is used the ON-OFF button, operation switch button and TEMP. adjustment button do not operate.
- "NOT AVAILABLE" is displayed when the Airflow direction button or Louver button are pressed. This indicates that this room unit is not equipped with the fan direction adjustment function and the louver function.
- When power is turned ON for the first time, it is normal that "H0" is displayed on the room temperature indication (For max. 2minutes). Please wait until this "H0" indication disappear then start the operation.

# 4

# SPECIFICATION

## 1. Heat pump type Rating Conditions (ISO T1)

Item	Service Ref.	With Electric heater		PEHD-P1.6EAH		PEHD-P2EAH	
		Without Electric heater		PEAD-P1.6EA		PEAD-P2EA	
Function				Cooling	Heating	Cooling	Heating
Capacity	*1		Btu/h	15,300	16,700 (20,100)	18,900	21,000 (24,400)
			W	4,500	4,900 (5,900)	5,550	6,150 (7,150)
Total input	*1		kW	1.75	1.80 (2.80)	2.44	2.22 (3.22)
INDOOR UNIT							
Service Ref.		With Electric heater		PEHD-P1.6EAH		PEHD-P2EAH	
		Without Electric heater		PEAD-P1.6EA		PEAD-P2EA	
Power supply				Single phase,50Hz,220-240V			
Input	*2		kW	0.13	0.13 <1.13>	0.15	0.15 <1.15>
Running current	*2		A	0.55	0.55 <4.71>	0.63	0.63 <4.79>
Starting current	*2		A	-	-	-	-
External finish				Galvanized sheets			
Heat exchanger				Plate fin coil			
Fan		Fan (drive) × No.		Centrifugal (direct) × 2			
			kW	0.043 (at 70 Pa)		0.076 (at 70 Pa)	
			m³/min (CFM)	11-14 <388-494>		13.5-17 <477-600>	
			Pa (mmAq)	30/70			
Booster heater	*2		kW	<1.0>		<1.0>	
Operation control & Thermostat				Built in remote controller			
Noise level (Lo-Hi)				34-38		36-40	
Unit drain pipe O.D			mm (in.)	32 (1-1/4)			
Dimensions		W	mm (in.)	935 (36-13/16)			
		D	mm (in.)	700 (27-5/8)			
		H	mm (in.)	295 (11-5/8)			
Weight		With Electric heater		35 (77)		35 (77)	
		Without Electric heater		33 (73)		33 (73)	
OUTDOOR UNIT							
Service Ref.				PUH-P1.6VGA/YGA		PUH-P2VGA/YGA	
Power supply				Single phase,50Hz,220-240V / 3 phase,50Hz,380-415V (4 wires)			
Input			kW	1.62	1.67	2.44	2.22
Running current			A	7.43/2.67	7.43/2.86	10.39/3.88	9.36/4.02
Starting current			A	36/20		74/30	
External finish				Munsell 5Y 8/1			
Refrigerant control				Linear Expansion Valve			
Compressor				Hermetic			
Model				RE277VHSM/RE277YFKM		NE38VMJM/NE38YEJM	
Motor output			kW	1.3		1.7	
Starter type				Line start			
Protection devices				VGA...Inner thermostat, HP switch, Discharge thermo. YGA...Thermal relay, Discharge thermo, HP switch, Anti-phase protector.			
Crankcase heater			W	30		38	
Heat exchanger				Plate fin coil			
Fan		Fan (drive) × No.		Propeller (direct) × 1		Propeller (direct) × 1	
			kW	0.070		0.070	
			m³/min (CFM)	45 (1,590)		55 (1,940)	
Defrost method				Reverse cycle			
Noise level		Cooling	dB	46		48	
		Heating	dB	48		49	
Dimensions		W	mm (in.)	900 (35-7/16)			
		D	mm (in.)	330+20 (13+3/4)			
		H	mm (in.)	650 (25-5/8)		855 (33-5/8)	
Weight			kg (lbs)	55 (121)		71 (157)	
REFRIGERANT PIPING							
Refrigerant				R407C			
Charge			kg (lbs)	2.6 (5.7)		3.1 (6.8)	
Oil (Model)			L	0.57 (Ester) MEL56		1.2 (Ester) MEL56	
Pipe size O.D		Liquid	mm (in.)	9.52 (3/8)			
		Gas	mm (in.)	15.88 (5/8)			
Connection method		Indoor side		Flared			
		Outdoor side		Flared			
Between the indoor & outdoor unit		Height difference		Max.40m			
		Piping length		Max.40m			

Notes 1. Rating Conditions (ISO T1)  
 Cooling: Indoor: D.B.27°C (80°F), W.B.19°C (66°F)  
 Outdoor: D.B.35°C (95°F), W.B.24°C (75°F)  
 Heating: Indoor: D.B.20°C (68°F)  
 Outdoor: D.B.7°C (45°F), W.B.6°C (43°F)  
 Refrigerant piping length (one way): 5m (16ft)

### 2. Guaranteed operating range

		Indoor	Outdoor
		Cooling	Upper limit D.B.35°C, W.B.22.5°C Lower limi D.B.19°C, W.B.15°C
Heating	Upper limit D.B.28°C Lower limi D.B.17°C	D.B.24°C, W.B.18°C D.B.-11°C, W.B.-12°C	

3. Above data based on indicated voltage  
 Indoor Unit: Single phase 240V 50Hz  
 Outdoor Unit: Single phase 240V 50Hz / 3 phase 415V 50Hz

\*1 : ( ) Shows the total rating.  
 \*2 : < > Shows only the booster heater rating.



## Rating Conditions (ISO T1)

Item	Service Ref.	With Electric heater		PEHD-P2.5EAH	
		Without Electric heater		PEAD-P2.5EA	
Function				Cooling	Heating
Capacity	*1	Btu/h		22,800	24,500 (29,700)
		W		6,700	7,200 (8,700)
Total input	*1	kW		2.68	2.45 (3.95)
Service Ref.		With Electric heater		PEHD-P2.5EAH	
		Without Electric heater		PEAD-P2.5EA	
Power supply		Single phase,50Hz,220-240V			
	Input	*2	kW	0.17	0.17<1.67>
	Running current	*2	A	0.72	0.72<6.96>
	Starting current	*2	A	-	-
External finish		Galvanized sheets			
Heat exchanger		Plate fin coil			
INDOOR UNIT	Fan	Fan (drive) × No.		Centrifugal (direct) × 2	
		Fan motor output		0.116 (at 70 Pa)	
		Airflow (Lo-Hi)		17-21<600-741>	
		External static pressure		30/70	
Booster heater		*2	kW	<1.5>	
Operation control & Thermostat		Built in remote controller			
Noise level (Lo-Hi)		37-41			
Unit drain pipe O.D		32 (1-1/4)			
Dimensions	W	mm (in.)		1,175 (46-1/8)	
	D	mm (in.)		700 (27-5/8)	
	H	mm (in.)		295 (11-5/8)	
Weight	With Electric heater		44 (97)		
	Without Electric heater		42 (92)		
Service Ref.		PUH-P2.5VGA/YGA			
Power supply		Single phase,50Hz,220-240V / 3 phase,50Hz,380-415V (4 wires)			
	Input	kW		2.51	2.28
	Running current	A		11.27/4.11	10.32/4.03
	Starting current	A		77/32	
External finish		Munsell 5Y 8/1			
Refrigerant control		Linear Expansion Valve			
Compressor		Hermetic			
	Model	NE41VMJM/NE41YEJM			
	Motor output	kW		1.9	
	Starter type	Line start			
	Protection devices	VGA...Inner thermostat, HP switch, Discharge thermo. YGA...Thermal relay, Discharge thermo, HP switch, Anti-phase protector.			
	Crankcase heater	W		38	
Heat exchanger		Plate fin coil			
OUTDOOR UNIT	Fan	Fan (drive) × No.		Propeller (direct) × 1	
		Fan motor output		0.070	
		Airflow		50 (1,770)	
Defrost method		Reverse cycle			
Noise level	Cooling	dB		48	
	Heating	dB		50	
Dimensions	W	mm (in.)		900 (35-7/16)	
	D	mm (in.)		330+20 (13+3/4)	
	H	mm (in.)		855 (33-5/8)	
Weight		kg (lbs)		82 (181)	
Refrigerant		R407C			
	Charge	kg (lbs)		3.3 (7.3)	
	Oil (Model)	L		1.2 (Ester) MEL56	
Pipe size O.D	Liquid	mm (in.)		9.52 (3/8)	
	Gas	mm (in.)		15.88 (5/8)	
Connection method	Indoor side		Flared		
	Outdoor side		Flared		
Between the indoor & outdoor unit	Height difference		Max.50m		
	Piping length		Max.50m		

Notes 1. Rating Conditions (ISO T1)  
 Cooling: Indoor: D.B.27°C (80°F), W.B.19°C (66°F)  
 Outdoor: D.B.35°C (95°F), W.B.24°C (75°F)  
 Heating: Indoor: D.B.20°C (68°F)  
 Outdoor: D.B.7°C (45°F), W.B.6°C (43°F)  
 Refrigerant piping length (one way): 5m (16ft)

### 2. Guaranteed operating range

		Indoor	Outdoor
		Cooling	Upper limit D.B.35°C, W.B.22.5°C
	Lower limi	D.B.19°C, W.B.15°C	D.B.-5°C
Heating	Upper limit	D.B.28°C	D.B.24°C, W.B.18°C
	Lower limi	D.B.17°C	D.B.-11°C, W.B.-12°C

3. Above data based on indicated voltage  
 Indoor Unit: Single phase 240V 50Hz  
 Outdoor Unit: Single phase 240V 50Hz / 3 phase 415V 50Hz

\*1 : ( ) Shows the total rating.  
 \*2 : < > Shows only the booster heater rating.

## Rating Conditions (ISO T1)

Item	Service Ref.	With Electric heater		PEHD-P3EAH		PEHD-P4EAH	
		Without Electric heater		PEAD-P3EA		PEAD-P4EA	
Function				Cooling	Heating	Cooling	Heating
Capacity	*1	Btu/h	26,300	31,000 (38,200)	33,100	35,500 (43,700)	
		W	7,700	9,100 (11,200)	9,700	10,400 (12,800)	
Total input	*1	kW	3.41	3.24 (5.34)	3.90	4.07 (6.47)	
INDOOR UNIT							
Service Ref.		With Electric heater		PEHD-P3EAH		PEHD-P4EAH	
		Without Electric heater		PEAD-P3EA		PEAD-P4EA	
Power supply				Single phase,50Hz,220-240V			
		*2	kW	0.40	0.40 <2.50>	0.62	0.62 <3.02>
		*2	A	1.70	1.70 <10.41>	2.64	2.64 <12.58>
		*2	A	-	-	-	-
External finish				Galvanized sheets			
Heat exchanger				Plate fin coil			
Fan		Fan (drive) × No.		Centrifugal (direct) × 2			
			kW	0.15		0.27	
			m³/min (CFM)	20-25 <706-883>		27-34 <953-1,200>	
			Pa (mmAq)	70 (130)			
Booster heater		*2	kW	<2.1>		<2.4>	
Operation control & Thermostat				Built in remote controller			
Noise level (Lo-Hi)			dB	37-41		41-46	
Unit drain pipe O.D			mm (in.)	32 (1-1/4)			
Dimensions		W	mm (in.)	1,175 (46-1/8)		1,415 (55-11/16)	
		D	mm (in.)	740 (29-1/8)			
		H	mm (in.)	325 (12-13/16)			
Weight		With Electric heater		46 (101)		65 (143)	
		Without Electric heater		44 (97)		62 (136)	
OUTDOOR UNIT							
Service Ref.				PUH-P3VGA/YGA		PUH-P4YGA	
Power supply				Single phase,50Hz,220-240V / 3 phase,50Hz,380-415V (4 wires)		3 phase,50Hz,380-415V (4 wires)	
			kW	3.01	2.84	3.28	3.45
			A	13.73/5.46	13.12/5.76	5.49	5.79
			A	93/41		45	
External finish				Munsell 5Y 8/1			
Refrigerant control				Linear Expansion Valve			
Compressor				Hermetic			
Model				NE52VNJM/NE52YDJM		NE56YDJM	
Motor output			kW	2.5		2.7	
Starter type				Line start			
Protection devices				VGA...Inner thermostat, HP switch, Discharge thermo. YGA...Thermal relay, Discharge thermo, HP switch, Anti-phase protector.			
Crankcase heater			W	38			
Heat exchanger				Plate fin coil			
Fan		Fan (drive) × No.		Propeller (direct) × 1		Propeller (direct) × 2	
			kW	0.070		0.070+0.070	
			m³/min (CFM)	50 (1,770)		85 (3,000)	
Defrost method				Reverse cycle			
Noise level		Cooling	dB	49		51	
		Heating	dB	51		53	
Dimensions		W	mm (in.)	900 (35-7/16)			
		D	mm (in.)	330+20 (13+3/4)			
		H	mm (in.)	855 (33-5/8)		1,260 (49-5/8)	
Weight			kg (lbs)	82 (181)		96 (212)	
REFRIGERANT PIPING							
Refrigerant				R407C			
Charge			kg (lbs)	3.7 (8.2)		4.0 (8.8)	
Oil (Model)				1.6 (Ester) MEL56			
Pipe size O.D		Liquid	mm (in.)	9.52 (3/8)			
		Gas	mm (in.)	15.88 (5/8)		19.05 (3/4)	
Connection method		Indoor side		Flared			
		Outdoor side		Flared			
Between the indoor & outdoor unit		Height difference		Max.50m			
		Piping length		Max.50m			

Notes 1. Rating Conditions (ISO T1)  
 Cooling: Indoor: D.B.27°C (80°F), W.B.19°C (66°F)  
 Outdoor: D.B.35°C (95°F), W.B.24°C (75°F)  
 Heating: Indoor: D.B.20°C (68°F)  
 Outdoor: D.B.7°C (45°F), W.B.6°C (43°F)  
 Refrigerant piping length (one way): 5m (16ft)

2. Guaranteed operating range

		Indoor	Outdoor
Cooling	Upper limit	D.B.35°C, W.B.22.5°C	D.B.46°C
	Lower limi	D.B.19°C, W.B.15°C	D.B.-5°C
Heating	Upper limit	D.B.28°C	D.B.24°C, W.B.18°C
	Lower limi	D.B.17°C	D.B.-11°C, W.B.-12°C

3. Above data based on indicated voltage  
 Indoor Unit: Single phase 240V 50Hz  
 Outdoor Unit: Single phase 240V 50Hz / 3 phase 415V 50Hz

\*1 : ( ) Shows the total rating.  
 \*2 : < > Shows only the booster heater rating.

### Rating Conditions (ISO T1)

Item	Service Ref.	With Electric heater		PEHD-P5EAH		PEHD-P6EAH	
		Without Electric heater		PEAD-P5EA		PEAD-P6EA	
Function				Cooling	Heating	Cooling	Heating
Capacity	*1	Btu/h		42,000	47,400 (57,700)	48,100	57,000 (67,200)
		W		12,300	13,900 (16,900)	14,100	16,700 (19,700)
Total input	*1	kW		4.93	4.81 (7.81)	5.90	5.96 (8.96)
Service Ref.		With Electric heater		PEHD-P5EAH		PEHD-P6EAH	
		Without Electric heater		PEAD-P5EA		PEAD-P6EA	
Power supply				Single phase,50Hz,220-240V			
		*2	kW	0.64	0.64 <3.64>	0.66	0.66 < 3.66>
		*2	A	2.72	2.72 <15.17>	2.79	2.79 <15.24>
		*2	A	-	-	-	-
External finish				Galvanized sheets			
Heat exchanger				Plate fin coil			
Fan		Fan (drive) × No.		Centrifugal (direct) × 2			
		Fan motor output		0.40			
		Airflow (Lo-Hi)		33.5-42 <1,183-1,483>		36.5-46 <1,288-1,624>	
		External static pressure		70 (130)			
Booster heater		*2	kW	<3.0>		<3.0>	
Operation control & Thermostat				Built in remote controller			
Noise level (Lo-Hi)				44-50		46-51	
Unit drain pipe O.D				32 (1-1/4)			
Dimensions		W	mm (in.)	1,415 (55-11/16)		1,715 (67-1/2)	
		D	mm (in.)	740 (29-1/8)			
		H	mm (in.)	325 (12-13/16)			
Weight		With Electric heater		68 (150)		73 (161)	
		Without Electric heater		65 (143)		70 (154)	
Service Ref.				PUH-P5YGA		PUH-P6YGA	
Power supply				3 phase,50Hz,380-415V (4 wires)			
			kW	4.29	4.17	5.24	5.30
			A	8.39	8.74	10.17	10.28
			A	79		84	
External finish				Munsell 5Y 8/1			
Refrigerant control				Linear Expansion Valve			
Compressor				Hermetic			
		Model		HE86YAA		HE101YAA	
		Motor output		4.3		5.1	
		Starter type		Line start			
Protection devices				Anti-phase protector, Internal thermostat, LP switch, HP switch, thermal relay, Discharge thermo			
Crankcase heater			W	38			
Heat exchanger				Plate fin coil			
Fan		Fan (drive) × No.		Propeller (direct) × 2			
		Fan motor output		0.075+0.075			
		Airflow		95 (3,360)		100 (3,530)	
Defrost method				Reverse cycle			
Noise level		Cooling	dB	53		55	
		Heating	dB	55		57	
Dimensions		W	mm (in.)	1,050 (41-5/16)			
		D	mm (in.)	330+20 (13+3/4)			
		H	mm (in.)	1,260 (49-5/8)			
Weight				122 (269)			
Refrigerant				R407C			
		Charge		5.8 (12.8)			
		Oil (Model)		2.0 (Ester) MEL32			
Pipe size O.D		Liquid	mm (in.)	9.52 (3/8)			
		Gas	mm (in.)	19.05 (3/4)			
Connection method		Indoor side		Flared			
		Outdoor side		Flared			
Between the indoor & outdoor unit		Height difference		Max.50m			
		Piping length		Max.50m			

Notes 1. Rating Conditions (ISO T1)  
 Cooling: Indoor: D.B.27°C (80°F), W.B.19°C (66°F)  
 Outdoor: D.B.35°C (95°F), W.B.24°C (75°F)  
 Heating: Indoor: D.B.20°C (68°F)  
 Outdoor: D.B.7°C (45°F), W.B.6°C (43°F)  
 Refrigerant piping length (one way): 5m (16ft)

2. Guaranteed operating range

		Indoor	Outdoor
Cooling	Upper limit	D.B.35°C, W.B.22.5°C	D.B.46°C
	Lower limit	D.B.19°C, W.B.15°C	D.B.-5°C
Heating	Upper limit	D.B.28°C	D.B.24°C, W.B.18°C
	Lower limit	D.B.17°C	D.B.-11°C, W.B.-12°C

3. Above data based on indicated voltage  
 Indoor Unit: Single phase 240V 50Hz  
 Outdoor Unit: 3 phase 415V 50Hz

\*1 : ( ) Shows the total rating.  
 \*2 : < > Shows only the booster heater rating.

## 2. Cooling only type Rating Conditions (ISO T1)

Service Ref.			PEAD-P1.6EA	PEAD-P2EA
Item			PEAD-P1.6EA	PEAD-P2EA
Function			Cooling	Cooling
Capacity		Btu/h	15,300	18,900
		W	4,500	5,550
Total input		kW	1.75	2.44
Service Ref.			PEAD-P1.6EA	PEAD-P2EA
Power supply			Single phase,50Hz,220-240V	
Input		kW	0.13	0.15
Running current		A	0.55	0.63
Starting current		A	-	-
External finish			Galvanized sheets	
Heat exchanger			Plate fin coil	
Fan			Centrifugal (direct) × 2	
Fan (drive) × No.				
Fan motor output		kW	0.043 (at 70 Pa)	0.076 (at 70 Pa)
Airflow (Lo-Hi)		m³/min (CFM)	11-14 <388-494>	13.5-17 <477-600>
External static pressure		Pa (mmAq)	30/70	
Booster heater			-	
Operation control & Thermostat			Built in remote controller	
Noise level (Lo-Hi)		dB	34-38	36-40
Unit drain pipe O.D		mm (in.)	32 (1-1/4)	
Dimensions		W mm (in.)	935 (36-13/16)	
		D mm (in.)	700 (27-5/8)	
		H mm (in.)	295 (11-5/8)	
Weight		kg (lbs)	33 (73)	
Service Ref.			PU-P1.6VGA	PU-P2VGA
Power supply			Single phase,50Hz,220-240V	
Input		kW	1.62	2.44
Running current		A	7.43	10.39
Starting current		A	36	74
External finish			Munsell 5Y 8/1	
Refrigerant control			Linear Expansion Valve	
Compressor			Hermetic	
Model			RE277VHSM	NE38VMJM
Motor output		kW	1.3	1.7
Starter type			Line start	
Protection devices			Inner thermostat, HP switch, Discharge thermo.	
Crankcase heater		W	30	38
Heat exchanger			Plate fin coil	
Fan			Propeller (direct) × 1	
Fan (drive) × No.				
Fan motor output		kW	0.070	
Airflow		m³/min (CFM)	45 (1,590)	55 (1,940)
Defrost method			-	
Noise level		Cooling dB	46	48
Dimensions		W mm (in.)	900 (35-7/16)	
		D mm (in.)	330+20 (13+3/4)	
		H mm (in.)	650 (25-5/8)	855 (33-5/8)
Weight		kg (lbs)	55 (121)	71 (157)
Refrigerant			R407C	
Charge		kg (lbs)	2.6 (5.7)	3.1 (6.8)
Oil (Model)		L	0.57 (Ester) MEL56	1.2 (Ester) MEL56
Pipe size O.D		Liquid mm (in.)	9.52 (3/8)	
		Gas mm (in.)	15.88 (5/8)	
Connection method		Indoor side	Flared	
		Outdoor side	Flared	
Between the indoor & outdoor unit		Height difference	Max.40m	
		Piping length	Max.40m	

- Notes 1. Rating Conditions (ISO T1)  
 Cooling: Indoor: D.B.27°C (80°F), W.B. 19°C (66°F)  
 Outdoor: D.B.35°C (95°F), W.B. 24°C (75°F)  
 Refrigerant piping length (one way): 5m (16ft)

2. Guaranteed operating range

		Indoor	Outdoor
Cooling	Upper limit	D.B.35°C, W.B.22.5°C	D.B.46°C
	Lower limit	D.B.19°C, W.B.15°C	D.B.-5°C

3. Above data based on indicated voltage  
 Indoor Unit: Single phase 240V 50Hz  
 Outdoor Unit: Single phase 240V 50Hz

## Rating Conditions (ISO T1)

Item		Service Ref.	PEAD-P2.5EA	
Function			Cooling	
Capacity		Btu/h	22,800	
		W	6,700	
Total input		kW	2.68	
Service Ref.			PEAD-P2.5EA	
Power supply			Single phase,50Hz,220-240V	
Input		kW	0.17	
Running current		A	0.72	
Starting current		A	-	
External finish			Galvanized sheets	
Heat exchanger			Plate fin coil	
INDOOR UNIT	Fan	Fan (drive) × No.	Centrifugal (direct) × 2	
		Fan motor output	0.116 (at 70 Pa)	
		Airflow (Lo-Hi)	17-21 <600-741>	
		External static pressure	Pa (mmAq)	30/70
Booster heater		kW	-	
Operation control & Thermostat			Built in remote controller	
Noise level (Lo-Hi)		dB	37-41	
Unit drain pipe O.D		mm (in.)	32 (1-1/4)	
Dimensions	W	mm (in.)	1,175 (46-1/8)	
	D	mm (in.)	700 (27-5/8)	
	H	mm (in.)	295 (11-5/8)	
Weight		kg (lbs)	42 (92)	
Service Ref.			PU-P2.5VGA1	
Power supply			Single phase,50Hz,220-240V	
Input		kW	2.51	
Running current		A	11.27	
Starting current		A	77	
External finish			Munsell 5Y 8/1	
Refrigerant control			Linear Expansion Valve	
OUTDOOR UNIT	Compressor		Hermetic	
		Model	NE41VMJM	
		Motor output	kW	1.9
		Starter type		Line start
		Protection devices		Inner thermostat, HP switch, Discharge thermo.
		Crankcase heater	W	38
Heat exchanger			Plate fin coil	
Fan	Fan (drive) × No.		Propeller (direct) × 1	
		Fan motor output	kW	0.070
		Airflow	m³/min (CFM)	50 (1,770)
Defrost method			-	
Noise level		Cooling dB	48	
Dimensions	W	mm (in.)	900 (35-7/16)	
	D	mm (in.)	330+20 (13+3/4)	
	H	mm (in.)	855 (33-5/8)	
Weight		kg (lbs)	82 (181)	
REFRIGERANT PIPING	Refrigerant		R407C	
	Charge		kg (lbs)	3.3 (7.3)
	Oil (Model)		L	1.2 (Ester) MEL56
	Pipe size O.D	Liquid	mm (in.)	9.52 (3/8)
		Gas	mm (in.)	15.88 (5/8)
	Connection method	Indoor side		Flared
		Outdoor side		Flared
	Between the indoor & outdoor unit	Height difference		Max.50m
Piping length			Max.50m	

- Notes 1. Rating Conditions (ISO T1)  
Cooling: Indoor: D.B.27°C (80°F), W.B. 19°C (66°F)  
Outdoor: D.B.35°C (95°F), W.B. 24°C (75°F)  
Refrigerant piping length (one way) : 5m (16ft)

2. Guaranteed operating range

		Indoor	Outdoor
Cooling	Upper limit	D.B.35°C, W.B.22.5°C	D.B.46°C
	Lower limit	D.B.19°C, W.B.15°C	D.B.-5°C

3. Above data based on indicated voltage  
Indoor Unit: Single phase 240V 50Hz  
Outdoor Unit: Single phase 240V 50Hz

### Rating Conditions (ISO T1)

Service Ref.			PEAD-P3EA	PEAD-P4EA		
Item			PEAD-P3EA	PEAD-P4EA		
Function			Cooling	Cooling		
Capacity		Btu/h	26,300	33,100		
		W	7,700	9,700		
Total input		kW	3.41	3.90		
Service Ref.			PEAD-P3EA	PEAD-P4EA		
Power supply			Single phase,50Hz,220-240V			
Input		kW	0.40	0.62		
Running current		A	1.70	2.64		
Starting current		A	-	-		
External finish			Galvanized sheets			
Heat exchanger			Plate fin coil			
INDOOR UNIT	Fan		Centrifugal (direct) × 2			
	Fan (drive) × No.					
	Fan motor output		kW	0.15	0.27	
	Airflow (Lo-Hi)		m³/min (CFM)	20-25 <706-883>	27-34 <953-1,200>	
External static pressure		Pa (mmAq)	70 (130)			
Booster heater			kW			
Operation control & Thermostat			Built in remote controller			
Noise level (Lo-Hi)			dB	37-41	41-46	
Unit drain pipe O.D			mm (in.)			
Dimensions			32 (1-1/4)			
W		mm (in.)	1,175 (46-1/8)		1,415 (55-11/16)	
D		mm (in.)	740 (29-1/8)			
H		mm (in.)	325 (12-13/16)			
Weight			kg (lbs)	44 (97)	62 (136)	
Service Ref.			PU-P3VGA/YGA	PU-P4YGA		
Power supply			Single phase,50Hz,220-240V / 3 phase,50Hz,380-415V (4 wires)			
Input		kW	3.01	3.28		
Running current		A	13.73/5.46	5.49		
Starting current		A	93/41	45		
External finish			Munsell 5Y 8/1			
Refrigerant control			Linear Expansion Valve			
Compressor			Hermetic			
Model			NE52VNJM/NE52YDJM	NE56YDJM		
Motor output		kW	2.5	2.7		
Starter type			Line start			
Protection devices			VGA...Inner thermostat, HP switch, Discharge thermo. YGA...Thermal relay, Discharge thermo, HP switch, Anti-phase protector.			
Crankcase heater		W	38			
Heat exchanger			Plate fin coil			
OUTDOOR UNIT	Fan		Propeller (direct) × 1			
	Fan (drive) × No					
	Fan motor output		kW	0.070	0.070+0.070	
Airflow		m³/min (CFM)	50 (1,770)	85 (3,000)		
Defrost method			-			
Noise level			Cooling	dB	49	51
Dimensions			900 (35-7/16)			
W		mm (in.)	330+20 (13+3/4)			
D		mm (in.)	855 (33-5/8)		1,260 (49-5/8)	
H		mm (in.)	82 (181)		96 (212)	
Weight			kg (lbs)	82 (181)	96 (212)	
Refrigerant			R407C			
Charge		kg (lbs)	3.7 (8.2)	4.0 (8.8)		
Oil (Model)		L	1.6 (Ester) MEL56			
Pipe size O.D			9.52 (3/8)			
Liquid		mm (in.)	15.88 (5/8)		19.05 (3/4)	
Gas		mm (in.)				
Connection method			Indoor side			
			Outdoor side			
Between the indoor & outdoor unit			Height difference			
			Piping length			
			Flared			
			Flared			
			Max.50m			
			Max.50m			

Notes 1. Rating Conditions (ISO T1)  
 Cooling: Indoor: D.B.27°C (80°F), W.B. 19°C (66°F)  
 Outdoor: D.B.35°C (95°F), W.B. 24°C (75°F)  
 Refrigerant piping length (one way) : 5m (16ft)

2. Guaranteed operating range

		Indoor	Outdoor
Cooling	Upper limit	D.B.35°C, W.B.22.5°C	D.B.46°C
	Lower limi	D.B.19°C, W.B.15°C	D.B.-5°C

3. Above data based on indicated voltage

Indoor Unit: Single phase 240V 50Hz  
 Outdoor Unit: Single phase 240V 50Hz/3 phase 415V 50Hz

## Rating Conditions (ISO T1)

Item		Service Ref.	PEAD-P5EA	PEAD-P6EA		
Function			Cooling	Cooling		
Capacity		Btu/h	42,000	48,100		
		W	12,300	14,100		
Total input		kW	4.93	5.90		
Service Ref.			PEAD-P5EA	PEAD-P6EA		
Power supply			Single phase,50Hz,220-240V			
Input		kW	0.64	0.66		
Running current		A	2.72	2.79		
Starting current		A	-	-		
External finish			Galvanized sheets			
Heat exchanger			Plate fin coil			
INDOOR UNIT	Fan	Fan (drive) × No.		Centrifugal (direct) × 2		
		Fan motor output		kW	0.40	
		Airflow (Lo-Hi)		m³/min (CFM)	33.5-42 <1,183-1,483>	36.5-46 <1,288-1,624>
		External static pressure		Pa (mmAq)	70 (130)	
Booster heater		kW	-			
Operation control & Thermostat			Built in remote controller			
Noise level (Lo-Hi)		dB	44-50	46-51		
Unit drain pipe O.D		mm (in.)	32 (1-1/4)			
Dimensions		W	1,415 (55-11/16)	1,715 (67-1/2)		
		D	740 (29-1/8)			
		H	325 (12-13/16)			
Weight		kg (lbs)	65 (143)	70 (154)		
Service Ref.			PU-P5YGA	PU-P6YGA		
Power supply			3 phase,50Hz,380-415V (4 wires)			
Input		kW	4.29	5.24		
Running current		A	8.39	10.17		
Starting current		A	79	84		
External finish			Munsell 5Y 8/1			
Refrigerant control			Linear Expansion Valve			
Compressor			Hermetic			
Model			HE86YAA	HE101YAA		
Motor output		kW	4.3	5.1		
Starter type			Line start			
Protection devices			Anti-phase protector, Internal thermostat, LP switch, HP switch, thermal relay, Discharge thermo			
Crankcase heater		W	38			
Heat exchanger			Plate fin coil			
OUTDOOR UNIT	Fan	Fan (drive) × No.		Propeller (direct) × 2		
		Fan motor output		kW	0.075+0.075	
		Airflow		m³/min (CFM)	95 (3,360)	100 (3,530)
Defrost method			-			
Noise level		Cooling	dB	53	55	
Dimensions		W	1050 (41-5/16)			
		D	330+20 (13+3/4)			
		H	1,260 (49-5/8)			
Weight		kg (lbs)	122 (269)			
Refrigerant			R407C			
Charge		kg (lbs)	5.8 (12.8)			
Oil (Model)		L	2.0 (Ester) MEL32			
Pipe size O.D		Liquid	mm (in.)		9.52 (3/8)	
		Gas	mm (in.)		19.05 (3/4)	
Connection method		Indoor side		Flared		
		Outdoor side		Flared		
Between the indoor & outdoor unit		Height difference		Max.50m		
		Piping length		Max.50m		

- Notes 1. Rating Conditions (ISO T1)  
Cooling: Indoor: D.B.27°C (80°F), W.B. 19°C (66°F)  
Outdoor: D.B.35°C (95°F), W.B. 24°C (75°F)  
Refrigerant piping length (one way) : 5m (16ft)

2. Guaranteed operating range

		Indoor	Outdoor
Cooling	Upper limit	D.B.35°C, W.B.22.5°C	D.B.46°C
	Lower limit	D.B.19°C, W.B.15°C	D.B.-5°C

3. Above data based on indicated voltage

Indoor Unit: Single phase 240V 50Hz  
Outdoor Unit: Single phase 240V 50Hz/3 phase 415V 50Hz

## 1. PERFORMANCE DATA

## 1) COOLING CAPACITY &lt;1&gt;

PEHD-P1.6EAH/PEAD-P1.6EA

Indoor Intake air D.B. (°C)	Indoor Intake air W.B. (°C)	Outdoor intake air D.B. (°C)											
		20				25				30			
		CA	SHC(W)	SHF	P.C.	CA	SHC(W)	SHF	P.C.	CA	SHC(W)	SHF	P.C.
20	16	4455	2762	0.62	1.40	4320	2678	0.62	1.48	4185	2595	0.62	1.56
	18	4770	2385	0.50	1.43	4635	2317	0.50	1.50	4478	2239	0.50	1.61
	20	5130	1949	0.38	1.47	5018	1907	0.38	1.54	4883	1855	0.38	1.64
22	16	4455	3118	0.70	1.40	4320	3024	0.70	1.48	4185	2929	0.70	1.56
	18	4770	2767	0.58	1.43	4635	2688	0.58	1.50	4478	2597	0.58	1.61
	20	5130	2360	0.46	1.47	5018	2308	0.46	1.54	4883	2246	0.46	1.64
24	16	4455	3475	0.78	1.40	4320	3370	0.78	1.48	4185	3264	0.78	1.56
	18	4770	3148	0.66	1.43	4635	3059	0.66	1.50	4478	2955	0.66	1.61
	20	5130	2770	0.54	1.47	5018	2709	0.54	1.54	4883	2637	0.54	1.64
26	16	4455	3831	0.86	1.40	4320	3715	0.86	1.48	4185	3599	0.86	1.56
	18	4770	3530	0.74	1.43	4635	3430	0.74	1.50	4478	3313	0.74	1.61
	20	5130	3181	0.62	1.47	5018	3111	0.62	1.54	4883	3027	0.62	1.64
28	16	4455	4188	0.94	1.40	4320	4061	0.94	1.48	4185	3934	0.94	1.56
	18	4770	3911	0.82	1.43	4635	3801	0.82	1.50	4478	3672	0.82	1.61
	20	5130	3591	0.70	1.47	5018	3512	0.70	1.54	4883	3418	0.70	1.64
30	16	4455	4455	1.00	1.40	4320	4320	1.00	1.48	4185	4185	1.00	1.56
	18	4770	4293	0.90	1.43	4635	4172	0.90	1.50	4478	4030	0.90	1.61
	20	5130	4001	0.78	1.47	5018	3914	0.78	1.54	4883	3808	0.78	1.64
32	16	4455	4455	1.00	1.40	4320	4320	1.00	1.48	4185	4185	1.00	1.56
	18	4770	4675	0.98	1.43	4635	4542	0.98	1.50	4478	4388	0.98	1.61
	20	5130	4412	0.86	1.47	5018	4315	0.86	1.54	4883	4199	0.86	1.64
34	16	4455	4455	1.00	1.40	4320	4320	1.00	1.48	4185	4185	1.00	1.56
	18	4770	4770	1.00	1.43	4635	4635	1.00	1.50	4478	4478	1.00	1.61
	20	5130	4822	0.94	1.47	5018	4716	0.94	1.54	4883	4590	0.94	1.64

Indoor Intake air D.B. (°C)	Indoor Intake air W.B. (°C)	Outdoor intake air D.B. (°C)											
		35				40				45			
		CA	SHC(W)	SHF	P.C.	CA	SHC(W)	SHF	P.C.	CA	SHC(W)	SHF	P.C.
20	16	4005	2483	0.62	1.68	3825	2371	0.62	1.80	3645	2260	0.62	1.95
	18	4320	2160	0.50	1.72	4185	2092	0.50	1.86	3915	1957	0.50	2.00
	20	4680	1778	0.38	1.77	4500	1710	0.38	1.89	4230	1607	0.38	2.03
22	16	4005	2803	0.70	1.68	3825	2677	0.70	1.80	3645	2551	0.70	1.95
	18	4320	2506	0.58	1.72	4185	2427	0.58	1.86	3915	2271	0.58	2.00
	20	4680	2153	0.46	1.77	4500	2070	0.46	1.89	4230	1946	0.46	2.03
24	16	4005	3124	0.78	1.68	3825	2983	0.78	1.80	3645	2843	0.78	1.95
	18	4320	2851	0.66	1.72	4185	2762	0.66	1.86	3915	2584	0.66	2.00
	20	4680	2527	0.54	1.77	4500	2430	0.54	1.89	4230	2284	0.54	2.03
26	16	4005	3444	0.86	1.68	3825	3289	0.86	1.80	3645	3135	0.86	1.95
	18	4320	3197	0.74	1.72	4185	3097	0.74	1.86	3915	2897	0.74	2.00
	20	4680	2902	0.62	1.77	4500	2790	0.62	1.89	4230	2623	0.62	2.03
28	16	4005	3765	0.94	1.68	3825	3596	0.94	1.80	3645	3426	0.94	1.95
	18	4320	3542	0.82	1.72	4185	3432	0.82	1.86	3915	3210	0.82	2.00
	20	4680	3276	0.70	1.77	4500	3150	0.70	1.89	4230	2961	0.70	2.03
30	16	4005	4005	1.00	1.68	3825	3825	1.00	1.80	3645	3645	1.00	1.95
	18	4320	3888	0.90	1.72	4185	3767	0.90	1.86	3915	3524	0.90	2.00
	20	4680	3650	0.78	1.77	4500	3510	0.78	1.89	4230	3299	0.78	2.03
32	16	4005	4005	1.00	1.68	3825	3825	1.00	1.80	3645	3645	1.00	1.95
	18	4320	4234	0.98	1.72	4185	4101	0.98	1.86	3915	3837	0.98	2.00
	20	4680	4025	0.86	1.77	4500	3870	0.86	1.89	4230	3638	0.86	2.03
34	16	4005	4005	1.00	1.68	3825	3825	1.00	1.80	3645	3645	1.00	1.95
	18	4320	4320	1.00	1.72	4185	4185	1.00	1.86	3915	3915	1.00	2.00
	20	4680	4399	0.94	1.77	4500	4230	0.94	1.89	4230	3976	0.94	2.03

Notes CA: Capacity (W)

SHC (W): Sensible heat capacity

P.C.: Power consumption (kW)

SHF: Sensible heat factor



PEHD-P2EAH/PEAD-P2EA

Indoor Intake air D.B. (°C)	Indoor Intake air W.B. (°C)	Outdoor intake air D.B. (°C)											
		20				25				30			
		CA	SHC(W)	SHF	P.C.	CA	SHC(W)	SHF	P.C.	CA	SHC(W)	SHF	P.C.
20	16	5495	3501	0.64	1.95	5328	3395	0.64	2.06	5162	3289	0.64	2.18
	18	5883	3023	0.51	1.99	5717	2938	0.51	2.10	5522	2838	0.51	2.24
	20	6327	2471	0.39	2.05	6188	2417	0.39	2.15	6022	2352	0.39	2.29
22	16	5495	3953	0.72	1.95	5328	3833	0.72	2.06	5162	3713	0.72	2.18
	18	5883	3507	0.60	1.99	5717	3408	0.60	2.10	5522	3292	0.60	2.24
	20	6327	2991	0.47	2.05	6188	2926	0.47	2.15	6022	2847	0.47	2.29
24	16	5495	4405	0.80	1.95	5328	4271	0.80	2.06	5162	4138	0.80	2.18
	18	5883	3991	0.68	1.99	5717	3878	0.68	2.10	5522	3746	0.68	2.24
	20	6327	3511	0.56	2.05	6188	3434	0.56	2.15	6022	3342	0.56	2.29
	22	6743	2967	0.44	2.10	6605	2906	0.44	2.10	6438	2833	0.44	2.36
26	16	5495	4857	0.88	1.95	5328	4709	0.88	2.06	5162	4562	0.88	2.18
	18	5883	4474	0.76	1.99	5717	4348	0.76	2.10	5522	4200	0.76	2.24
	20	6327	4032	0.64	2.05	6188	3943	0.64	2.15	6022	3837	0.64	2.29
	22	6743	3506	0.52	2.10	6605	3434	0.52	2.10	6438	3348	0.52	2.36
28	16	5495	5308	0.97	1.95	5328	5147	0.97	2.06	5162	4987	0.97	2.18
	18	5883	4958	0.84	1.99	5717	4818	0.84	2.10	5522	4654	0.84	2.24
	20	6327	4552	0.72	2.05	6188	4452	0.72	2.15	6022	4332	0.72	2.29
	22	6743	4046	0.60	2.10	6605	3963	0.60	2.10	6438	3863	0.60	2.36
30	16	5495	5495	1.00	1.95	5328	5328	1.00	2.06	5162	5162	1.00	2.18
	18	5883	5442	0.93	1.99	5717	5288	0.93	2.10	5522	5108	0.93	2.24
	20	6327	5072	0.80	2.05	6188	4961	0.80	2.15	6022	4827	0.80	2.29
	22	6743	4585	0.68	2.10	6605	4491	0.68	2.10	6438	4378	0.68	2.36
32	16	5495	5495	1.00	1.95	5328	5328	1.00	2.06	5162	5162	1.00	2.18
	18	5883	5883	1.00	1.99	5717	5717	1.00	2.10	5522	5522	1.00	2.24
	20	6327	5592	0.88	2.05	6188	5470	0.88	2.15	6022	5323	0.88	2.29
	22	6743	5125	0.76	2.10	6605	5019	0.76	2.10	6438	4893	0.76	2.36
34	16	5495	5495	1.00	1.95	5328	5328	1.00	2.06	5162	5162	1.00	2.18
	18	5883	5883	1.00	1.99	5717	5717	1.00	2.10	5522	5522	1.00	2.24
	20	6327	6113	0.97	2.05	6188	5979	0.97	2.15	6022	5818	0.97	2.29
	22	6743	5664	0.84	2.10	6605	5548	0.84	2.10	6438	5408	0.84	2.36

Indoor Intake air D.B. (°C)	Indoor Intake air W.B. (°C)	Outdoor intake air D.B. (°C)											
		35				40				45			
		CA	SHC(W)	SHF	P.C.	CA	SHC(W)	SHF	P.C.	CA	SHC(W)	SHF	P.C.
20	16	4940	3148	0.64	2.34	4718	3006	0.64	2.51	4496	2865	0.64	2.72
	18	5328	2738	0.51	2.40	5162	2652	0.51	2.59	4829	2481	0.51	2.78
	20	5772	2254	0.39	2.46	5550	2168	0.39	2.64	5217	2038	0.39	2.83
22	16	4940	3554	0.72	2.34	4718	3394	0.72	2.51	4496	3234	0.72	2.72
	18	5328	3176	0.60	2.40	5162	3077	0.60	2.59	4829	2878	0.60	2.78
	20	5772	2729	0.47	2.46	5550	2624	0.47	2.64	5217	2466	0.47	2.83
24	16	4940	3960	0.80	2.34	4718	3782	0.80	2.51	4496	3604	0.80	2.72
	18	5328	3614	0.68	2.40	5162	3501	0.68	2.59	4829	3275	0.68	2.78
	20	5772	3203	0.56	2.46	5550	3080	0.56	2.64	5217	2895	0.56	2.83
	22	6216	2735	0.44	2.52	5994	2637	0.44	2.71	5661	2491	0.44	2.88
26	16	4940	4366	0.88	2.34	4718	4170	0.88	2.51	4496	3974	0.88	2.72
	18	5328	4052	0.76	2.40	5162	3926	0.76	2.59	4829	3672	0.76	2.78
	20	5772	3678	0.64	2.46	5550	3537	0.64	2.64	5217	3324	0.64	2.83
	22	6216	3232	0.52	2.52	5994	3117	0.52	2.71	5661	2944	0.52	2.88
28	16	4940	4772	0.97	2.34	4718	4558	0.97	2.51	4496	4343	0.97	2.72
	18	5328	4490	0.84	2.40	5162	4350	0.84	2.59	4829	4069	0.84	2.78
	20	5772	4153	0.72	2.46	5550	3993	0.72	2.64	5217	3753	0.72	2.83
	22	6216	3730	0.60	2.52	5994	3596	0.60	2.71	5661	3397	0.60	2.88
30	16	4940	4940	1.00	2.34	4718	4718	1.00	2.51	4496	4496	1.00	2.72
	18	5328	4928	0.93	2.40	5162	4774	0.93	2.59	4829	4466	0.93	2.78
	20	5772	4627	0.80	2.46	5550	4449	0.80	2.64	5217	4182	0.80	2.83
	22	6216	4227	0.68	2.52	5994	4076	0.68	2.71	5661	3849	0.68	2.88
32	16	4940	4940	1.00	2.34	4718	4718	1.00	2.51	4496	4496	1.00	2.72
	18	5328	5328	1.00	2.40	5162	5162	1.00	2.59	4829	4829	1.00	2.78
	20	5772	5102	0.88	2.46	5550	4906	0.88	2.64	5217	4611	0.88	2.83
	22	6216	4724	0.76	2.52	5994	4555	0.76	2.71	5661	4302	0.76	2.88
34	16	4940	4940	1.00	2.34	4718	4718	1.00	2.51	4496	4496	1.00	2.72
	18	5328	5328	1.00	2.40	5162	5162	1.00	2.59	4829	4829	1.00	2.78
	20	5772	5576	0.97	2.46	5550	5362	0.97	2.64	5217	5040	0.97	2.83
	22	6216	5221	0.84	2.52	5994	5035	0.84	2.71	5661	4755	0.84	2.88

Notes CA: Capacity (W) SHC (W): Sensible heat capacity  
P.C.: Power consumption (kW) SHF: Sensible heat factor

PEHD-P2.5EAH/PEAD-P2.5EA

Indoor Intake air D.B. (°C)	Indoor Intake air W.B. (°C)	Outdoor intake air D.B. (°C)											
		20				25				30			
		CA	SHC(W)	SHF	P.C.	CA	SHC(W)	SHF	P.C.	CA	SHC(W)	SHF	P.C.
20	16	6633	4055	0.61	2.14	6432	3932	0.61	2.26	6231	3810	0.61	2.40
	18	7102	3502	0.49	2.19	6901	3403	0.49	2.30	6667	3287	0.49	2.46
	20	7638	2862	0.37	2.25	7471	2799	0.37	2.36	7270	2724	0.37	2.52
22	16	6633	4579	0.69	2.14	6432	4440	0.69	2.26	6231	4301	0.69	2.40
	18	7102	4062	0.57	2.19	6901	3947	0.57	2.30	6667	3813	0.57	2.46
	20	7638	3465	0.45	2.25	7471	3389	0.45	2.36	7270	3297	0.45	2.52
24	16	6633	5102	0.77	2.14	6432	4947	0.77	2.26	6231	4793	0.77	2.40
	18	7102	4622	0.65	2.19	6901	4491	0.65	2.30	6667	4339	0.65	2.46
	20	7638	4067	0.53	2.25	7471	3978	0.53	2.36	7270	3871	0.53	2.52
	22	8141	3437	0.42	2.31	7973	3366	0.42	2.31	7772	3281	0.42	2.60
26	16	6633	5625	0.85	2.14	6432	5455	0.85	2.26	6231	5284	0.85	2.40
	18	7102	5182	0.73	2.19	6901	5036	0.73	2.30	6667	4865	0.73	2.46
	20	7638	4670	0.61	2.25	7471	4567	0.61	2.36	7270	4444	0.61	2.52
	22	8141	4061	0.50	2.31	7973	3978	0.50	2.31	7772	3878	0.50	2.60
28	16	6633	6148	0.93	2.14	6432	5962	0.93	2.26	6231	5776	0.93	2.40
	18	7102	5743	0.81	2.19	6901	5580	0.81	2.30	6667	5391	0.81	2.46
	20	7638	5272	0.69	2.25	7471	5157	0.69	2.36	7270	5018	0.69	2.52
	22	8141	4686	0.58	2.31	7973	4590	0.58	2.31	7772	4474	0.58	2.60
30	16	6633	6633	1.00	2.14	6432	6432	1.00	2.26	6231	6231	1.00	2.40
	18	7102	6303	0.89	2.19	6901	6125	0.89	2.30	6667	5917	0.89	2.46
	20	7638	5875	0.77	2.25	7471	5746	0.77	2.36	7270	5591	0.77	2.52
	22	8141	5311	0.65	2.31	7973	5202	0.65	2.31	7772	5071	0.65	2.60
32	16	6633	6633	1.00	2.14	6432	6432	1.00	2.26	6231	6231	1.00	2.40
	18	7102	6863	0.97	2.19	6901	6669	0.97	2.30	6667	6442	0.97	2.46
	20	7638	6477	0.85	2.25	7471	6335	0.85	2.36	7270	6165	0.85	2.52
	22	8141	5936	0.73	2.31	7973	5814	0.73	2.31	7772	5667	0.73	2.60
34	16	6633	6633	1.00	2.14	6432	6432	1.00	2.26	6231	6231	1.00	2.40
	18	7102	7102	1.00	2.19	6901	6901	1.00	2.30	6667	6667	1.00	2.46
	20	7638	7080	0.93	2.25	7471	6925	0.93	2.36	7270	6738	0.93	2.52
	22	8141	6561	0.81	2.31	7973	6426	0.81	2.31	7772	6264	0.81	2.60

Indoor Intake air D.B. (°C)	Indoor Intake air W.B. (°C)	Outdoor intake air D.B. (°C)											
		35				40				45			
		CA	SHC(W)	SHF	P.C.	CA	SHC(W)	SHF	P.C.	CA	SHC(W)	SHF	P.C.
20	16	5963	3646	0.61	2.57	5695	3482	0.61	2.76	5427	3318	0.61	2.99
	18	6432	3171	0.49	2.64	6231	3072	0.49	2.84	5829	2874	0.49	3.06
	20	6968	2611	0.37	2.70	6700	2511	0.37	2.90	6298	2360	0.37	3.11
22	16	5963	4116	0.69	2.57	5695	3931	0.69	2.76	5427	3746	0.69	2.99
	18	6432	3679	0.57	2.64	6231	3564	0.57	2.84	5829	3334	0.57	3.06
	20	6968	3161	0.45	2.70	6700	3039	0.45	2.90	6298	2857	0.45	3.11
24	16	5963	4587	0.77	2.57	5695	4380	0.77	2.76	5427	4174	0.77	2.99
	18	6432	4186	0.65	2.64	6231	4055	0.65	2.84	5829	3794	0.65	3.06
	20	6968	3710	0.53	2.70	6700	3568	0.53	2.90	6298	3354	0.53	3.11
	22	7504	3168	0.42	2.76	7236	3055	0.42	2.98	6834	2885	0.42	3.16
26	16	5963	5057	0.85	2.57	5695	4830	0.85	2.76	5427	4602	0.85	2.99
	18	6432	4694	0.73	2.64	6231	4547	0.73	2.84	5829	4254	0.73	3.06
	20	6968	4260	0.61	2.70	6700	4096	0.61	2.90	6298	3851	0.61	3.11
	22	7504	3744	0.50	2.76	7236	3610	0.50	2.98	6834	3410	0.50	3.16
28	16	5963	5527	0.93	2.57	5695	5279	0.93	2.76	5427	5031	0.93	2.99
	18	6432	5201	0.81	2.64	6231	5038	0.81	2.84	5829	4713	0.81	3.06
	20	6968	4810	0.69	2.70	6700	4625	0.69	2.90	6298	4347	0.69	3.11
	22	7504	4320	0.58	2.76	7236	4166	0.58	2.98	6834	3934	0.58	3.16
30	16	5963	5963	1.00	2.57	5695	5695	1.00	2.76	5427	5427	1.00	2.99
	18	6432	5708	0.89	2.64	6231	5530	0.89	2.84	5829	5173	0.89	3.06
	20	6968	5360	0.77	2.70	6700	5153	0.77	2.90	6298	4844	0.77	3.11
	22	7504	4896	0.65	2.76	7236	4721	0.65	2.98	6834	4459	0.65	3.16
32	16	5963	5963	1.00	2.57	5695	5695	1.00	2.76	5427	5427	1.00	2.99
	18	6432	6216	0.97	2.64	6231	6022	0.97	2.84	5829	5633	0.97	3.06
	20	6968	5909	0.85	2.70	6700	5682	0.85	2.90	6298	5341	0.85	3.11
	22	7504	5472	0.73	2.76	7236	5276	0.73	2.98	6834	4983	0.73	3.16
34	16	5963	5963	1.00	2.57	5695	5695	1.00	2.76	5427	5427	1.00	2.99
	18	6432	6432	1.00	2.64	6231	6231	1.00	2.84	5829	5829	1.00	3.06
	20	6968	6459	0.93	2.70	6700	6211	0.93	2.90	6298	5838	0.93	3.11
	22	7504	6048	0.81	2.76	7236	5832	0.81	2.98	6834	5508	0.81	3.16

Notes CA: Capacity (W) SHC (W): Sensible heat capacity  
P.C.: Power consumption (kW) SHF: Sensible heat factor

PEHD-P3EAH/PEAD-P3EA

Indoor Intake air D.B. (°C)	Indoor Intake air W.B. (°C)	Outdoor intake air D.B. (°C)											
		20				30				30			
		CA	SHC(W)	SHF	P.C.	CA	SHC(W)	SHF	P.C.	CA	SHC(W)	SHF	P.C.
20	16	7623	5120	0.67	2.72	7392	4965	0.67	2.88	7161	4810	0.67	3.05
	18	8162	4421	0.54	2.78	7931	4296	0.54	2.93	7662	4150	0.54	3.14
	20	8778	3614	0.41	2.86	8586	3534	0.41	3.00	8355	3439	0.41	3.20
22	16	7623	5781	0.76	2.72	7392	5606	0.76	2.88	7161	5430	0.76	3.05
	18	8162	5128	0.63	2.78	7931	4983	0.63	2.93	7662	4814	0.63	3.14
	20	8778	4374	0.50	2.86	8586	4278	0.50	3.00	8355	4163	0.50	3.20
24	16	7623	6441	0.84	2.72	7392	6246	0.84	2.88	7161	6051	0.84	3.05
	18	8162	5836	0.71	2.78	7931	5671	0.71	2.93	7662	5478	0.71	3.14
	20	8778	5135	0.59	2.86	8586	5023	0.59	3.00	8355	4887	0.59	3.20
	22	9356	4339	0.46	2.93	9163	4250	0.46	2.93	8932	4143	0.46	3.30
26	16	7623	7102	0.93	2.72	7392	6887	0.93	2.88	7161	6672	0.93	3.05
	18	8162	6543	0.80	2.78	7931	6358	0.80	2.93	7662	6142	0.80	3.14
	20	8778	5896	0.67	2.86	8586	5767	0.67	3.00	8355	5611	0.67	3.20
	22	9356	5128	0.55	2.93	9163	5022	0.55	2.93	8932	4896	0.55	3.30
28	16	7623	7623	1.00	2.72	7392	7392	1.00	2.88	7161	7161	1.00	3.05
	18	8162	7251	0.89	2.78	7931	7045	0.89	2.93	7662	6806	0.89	3.14
	20	8778	6657	0.76	2.86	8586	6511	0.76	3.00	8355	6335	0.76	3.20
	22	9356	5917	0.63	2.93	9163	5795	0.63	2.93	8932	5649	0.63	3.30
30	16	7623	7623	1.00	2.72	7392	7392	1.00	2.88	7161	7161	1.00	3.05
	18	8162	7958	0.98	2.78	7931	7733	0.98	2.93	7662	7470	0.98	3.14
	20	8778	7417	0.84	2.86	8586	7255	0.84	3.00	8355	7060	0.84	3.20
	22	9356	6705	0.72	2.93	9163	6568	0.72	2.93	8932	6402	0.72	3.30
32	16	7623	7623	1.00	2.72	7392	7392	1.00	2.88	7161	7161	1.00	3.05
	18	8162	8162	1.00	2.78	7931	7931	1.00	2.93	7662	7662	1.00	3.14
	20	8778	8178	0.93	2.86	8586	7999	0.93	3.00	8355	7784	0.93	3.20
	22	9356	7494	0.80	2.93	9163	7340	0.80	2.93	8932	7155	0.80	3.30
34	16	7623	7623	1.00	2.72	7392	7392	1.00	2.88	7161	7161	1.00	3.05
	18	8162	8162	1.00	2.78	7931	7931	1.00	2.93	7662	7662	1.00	3.14
	20	8778	8778	1.00	2.86	8586	8586	1.00	3.00	8355	8355	1.00	3.20
	22	9356	8283	0.89	2.93	9163	8113	0.89	2.93	8932	7908	0.89	3.30

Indoor Intake air D.B. (°C)	Indoor Intake air W.B. (°C)	Outdoor intake air D.B. (°C)											
		35				40				45			
		CA	SHC(W)	SHF	P.C.	CA	SHC(W)	SHF	P.C.	CA	SHC(W)	SHF	P.C.
20	16	6853	4603	0.67	3.27	6545	4396	0.67	3.51	6237	4189	0.67	3.80
	18	7392	4004	0.54	3.36	7161	3879	0.54	3.62	6699	3629	0.54	3.89
	20	8008	3297	0.41	3.44	7700	3170	0.41	3.68	7238	2980	0.41	3.96
22	16	6853	5197	0.76	3.27	6545	4963	0.76	3.51	6237	4730	0.76	3.80
	18	7392	4645	0.63	3.36	7161	4499	0.63	3.62	6699	4209	0.63	3.89
	20	8008	3991	0.50	3.44	7700	3837	0.50	3.68	7238	3607	0.50	3.96
24	16	6853	5791	0.84	3.27	6545	5531	0.84	3.51	6237	5270	0.84	3.80
	18	7392	5285	0.71	3.36	7161	5120	0.71	3.62	6699	4790	0.71	3.89
	20	8008	4685	0.59	3.44	7700	4505	0.59	3.68	7238	4234	0.59	3.96
	22	8624	4000	0.46	3.52	8316	3857	0.46	3.79	7854	3643	0.46	4.02
26	16	6853	6385	0.93	3.27	6545	6098	0.93	3.51	6237	5811	0.93	3.80
	18	7392	5926	0.80	3.36	7161	5741	0.80	3.62	6699	5370	0.80	3.89
	20	8008	5379	0.67	3.44	7700	5172	0.67	3.68	7238	4862	0.67	3.96
	22	8624	4727	0.55	3.52	8316	4558	0.55	3.79	7854	4305	0.55	4.02
28	16	6853	6853	1.00	3.27	6545	6545	1.00	3.51	6237	6237	1.00	3.80
	18	7392	6567	0.89	3.36	7161	6361	0.89	3.62	6699	5951	0.89	3.89
	20	8008	6073	0.76	3.44	7700	5839	0.76	3.68	7238	5489	0.76	3.96
	22	8624	5454	0.63	3.52	8316	5259	0.63	3.79	7854	4967	0.63	4.02
30	16	6853	6853	1.00	3.27	6545	6545	1.00	3.51	6237	6237	1.00	3.80
	18	7392	7207	0.98	3.36	7161	6982	0.98	3.62	6699	6532	0.98	3.89
	20	8008	6767	0.84	3.44	7700	6506	0.84	3.68	7238	6116	0.84	3.96
	22	8624	6181	0.72	3.52	8316	5960	0.72	3.79	7854	5629	0.72	4.02
32	16	6853	6853	1.00	3.27	6545	6545	1.00	3.51	6237	6237	1.00	3.80
	18	7392	7392	1.00	3.36	7161	7161	1.00	3.62	6699	6699	1.00	3.89
	20	8008	7461	0.93	3.44	7700	7174	0.93	3.68	7238	6743	0.93	3.96
	22	8624	6908	0.80	3.52	8316	6662	0.80	3.79	7854	6292	0.80	4.02
34	16	6853	6853	1.00	3.27	6545	6545	1.00	3.51	6237	6237	1.00	3.80
	18	7392	7392	1.00	3.36	7161	7161	1.00	3.62	6699	6699	1.00	3.89
	20	8008	8008	1.00	3.44	7700	7700	1.00	3.68	7238	7238	1.00	3.96
	22	8624	7636	0.89	3.52	8316	7363	0.89	3.79	7854	6954	0.89	4.02

Notes CA: Capacity (W) SHC (W): Sensible heat capacity  
P.C.: Power consumption (kW) SHF: Sensible heat factor

PEHD-P4EAH/PEAD-P4EA

Indoor Intake air D.B. (°C)	Indoor Intake air W.B. (°C)	Outdoor intake air D.B. (°C)											
		20				25				30			
		CA	SHC(W)	SHF	P.C.	CA	SHC(W)	SHF	P.C.	CA	SHC(W)	SHF	P.C.
20	16	9603	6202	0.65	3.12	9312	6014	0.65	3.29	9021	5826	0.65	3.49
	18	10282	5355	0.52	3.18	9991	5204	0.52	3.35	9652	5027	0.52	3.59
	20	11058	4377	0.40	3.27	10816	4281	0.40	3.43	10525	4166	0.40	3.66
22	16	9603	7002	0.73	3.12	9312	6790	0.73	3.29	9021	6578	0.73	3.49
	18	10282	6212	0.60	3.18	9991	6036	0.60	3.35	9652	5831	0.60	3.59
	20	11058	5299	0.48	3.27	10816	5182	0.48	3.43	10525	5043	0.48	3.66
24	16	9603	7802	0.81	3.12	9312	7566	0.81	3.29	9021	7330	0.81	3.49
	18	10282	7069	0.69	3.18	9991	6869	0.69	3.35	9652	6635	0.69	3.59
	20	11058	6220	0.56	3.27	10816	6084	0.56	3.43	10525	5920	0.56	3.66
	22	11786	5256	0.45	3.36	11543	5148	0.45	3.36	11252	5018	0.45	3.78
26	16	9603	8603	0.90	3.12	9312	8342	0.90	3.29	9021	8081	0.90	3.49
	18	10282	7926	0.77	3.18	9991	7701	0.77	3.35	9652	7440	0.77	3.59
	20	11058	7142	0.65	3.27	10816	6985	0.65	3.43	10525	6797	0.65	3.66
	22	11786	6211	0.53	3.36	11543	6083	0.53	3.36	11252	5930	0.53	3.78
28	16	9603	9403	0.98	3.12	9312	9118	0.98	3.29	9021	8833	0.98	3.49
	18	10282	8783	0.85	3.18	9991	8534	0.85	3.35	9652	8244	0.85	3.59
	20	11058	8063	0.73	3.27	10816	7886	0.73	3.43	10525	7674	0.73	3.66
	22	11786	7167	0.61	3.36	11543	7019	0.61	3.36	11252	6842	0.61	3.78
30	16	9603	9603	1.00	3.12	9312	9312	1.00	3.29	9021	9021	1.00	3.49
	18	10282	9639	0.94	3.18	9991	9367	0.94	3.35	9652	9048	0.94	3.59
	20	11058	8985	0.81	3.27	10816	8788	0.81	3.43	10525	8551	0.81	3.66
	22	11786	8122	0.69	3.36	11543	7955	0.69	3.36	11252	7755	0.69	3.78
32	16	9603	9603	1.00	3.12	9312	9312	1.00	3.29	9021	9021	1.00	3.49
	18	10282	10282	1.00	3.18	9991	9991	1.00	3.35	9652	9652	1.00	3.59
	20	11058	9906	0.90	3.27	10816	9689	0.90	3.43	10525	9428	0.90	3.66
	22	11786	9078	0.77	3.36	11543	8891	0.77	3.36	11252	8667	0.77	3.78
34	16	9603	9603	1.00	3.12	9312	9312	1.00	3.29	9021	9021	1.00	3.49
	18	10282	10282	1.00	3.18	9991	9991	1.00	3.35	9652	9652	1.00	3.59
	20	11058	10828	0.98	3.27	10816	10590	0.98	3.43	10525	10305	0.98	3.66
	22	11786	10034	0.85	3.36	11543	9827	0.85	3.36	11252	9579	0.85	3.78

Indoor Intake air D.B. (°C)	Indoor Intake air W.B. (°C)	Outdoor intake air D.B. (°C)											
		35				40				45			
		CA	SHC(W)	SHF	P.C.	CA	SHC(W)	SHF	P.C.	CA	SHC(W)	SHF	P.C.
20	16	8633	5575	0.65	3.74	8245	5325	0.65	4.01	7857	5074	0.65	4.35
	18	9312	4850	0.52	3.84	9021	4698	0.52	4.14	8439	4395	0.52	4.45
	20	10088	3993	0.40	3.93	9700	3840	0.40	4.21	9118	3609	0.40	4.53
22	16	8633	6295	0.73	3.74	8245	6012	0.73	4.01	7857	5729	0.73	4.35
	18	9312	5626	0.60	3.84	9021	5450	0.60	4.14	8439	5099	0.60	4.45
	20	10088	4834	0.48	3.93	9700	4648	0.48	4.21	9118	4369	0.48	4.53
24	16	8633	7014	0.81	3.74	8245	6699	0.81	4.01	7857	6384	0.81	4.35
	18	9312	6402	0.69	3.84	9021	6202	0.69	4.14	8439	5802	0.69	4.45
	20	10088	5675	0.56	3.93	9700	5456	0.56	4.21	9118	5129	0.56	4.53
	22	10864	4845	0.45	4.02	10476	4672	0.45	4.33	9894	4412	0.45	4.60
26	16	8633	7734	0.90	3.74	8245	7386	0.90	4.01	7857	7039	0.90	4.35
	18	9312	7178	0.77	3.84	9021	6954	0.77	4.14	8439	6505	0.77	4.45
	20	10088	6515	0.65	3.93	9700	6265	0.65	4.21	9118	5889	0.65	4.53
	22	10864	5726	0.53	4.02	10476	5521	0.53	4.33	9894	5214	0.53	4.60
28	16	8633	8453	0.98	3.74	8245	8073	0.98	4.01	7857	7693	0.98	4.35
	18	9312	7954	0.85	3.84	9021	7705	0.85	4.14	8439	7208	0.85	4.45
	20	10088	7356	0.73	3.93	9700	7073	0.73	4.21	9118	6649	0.73	4.53
	22	10864	6606	0.61	4.02	10476	6370	0.61	4.33	9894	6017	0.61	4.60
30	16	8633	8633	1.00	3.74	8245	8245	1.00	4.01	7857	7857	1.00	4.35
	18	9312	8730	0.94	3.84	9021	8457	0.94	4.14	8439	7912	0.94	4.45
	20	10088	8196	0.81	3.93	9700	7881	0.81	4.21	9118	7408	0.81	4.53
	22	10864	7487	0.69	4.02	10476	7220	0.69	4.33	9894	6819	0.69	4.60
32	16	8633	8633	1.00	3.74	8245	8245	1.00	4.01	7857	7857	1.00	4.35
	18	9312	9312	1.00	3.84	9021	9021	1.00	4.14	8439	8439	1.00	4.45
	20	10088	9037	0.90	3.93	9700	8690	0.90	4.21	9118	8168	0.90	4.53
	22	10864	8368	0.77	4.02	10476	8069	0.77	4.33	9894	7621	0.77	4.60
34	16	8633	8633	1.00	3.74	8245	8245	1.00	4.01	7857	7857	1.00	4.35
	18	9312	9312	1.00	3.84	9021	9021	1.00	4.14	8439	8439	1.00	4.45
	20	10088	9878	0.98	3.93	9700	9498	0.98	4.21	9118	8928	0.98	4.53
	22	10864	9249	0.85	4.02	10476	8919	0.85	4.33	9894	8423	0.85	4.60

Notes CA: Capacity (W) SHC (W): Sensible heat capacity  
P.C.: Power consumption (kW) SHF: Sensible heat factor

PEHD-P5EAH/PEAD-P5EA

Indoor Intake air D.B. (°C)	Indoor Intake air W.B. (°C)	Outdoor intake air D.B. (°C)											
		20				25				30			
		CA	SHC(W)	SHF	P.C.	CA	SHC(W)	SHF	P.C.	CA	SHC(W)	SHF	P.C.
20	16	12177	8179	0.67	3.94	11808	7931	0.67	4.17	11439	7683	0.67	4.41
	18	13038	7062	0.54	4.02	12669	6862	0.54	4.24	12239	6629	0.54	4.53
	20	14022	5772	0.41	4.14	13715	5646	0.41	4.33	13346	5494	0.41	4.63
22	16	12177	9234	0.76	3.94	11808	8954	0.76	4.17	11439	8675	0.76	4.41
	18	13038	8192	0.63	4.02	12669	7960	0.63	4.24	12239	7690	0.63	4.53
	20	14022	6988	0.50	4.14	13715	6834	0.50	4.33	13346	6650	0.50	4.63
24	16	12177	10290	0.84	3.94	11808	9978	0.84	4.17	11439	9666	0.84	4.41
	18	13038	9322	0.71	4.02	12669	9058	0.71	4.24	12239	8751	0.71	4.53
	20	14022	8203	0.59	4.14	13715	8023	0.59	4.33	13346	7807	0.59	4.63
	22	14945	6931	0.46	4.24	14637	6788	0.46	4.24	14268	6617	0.46	4.78
26	16	12177	11345	0.93	3.94	11808	11001	0.93	4.17	11439	10657	0.93	4.41
	18	13038	10452	0.80	4.02	12669	10156	0.80	4.24	12239	9811	0.80	4.53
	20	14022	9418	0.67	4.14	13715	9212	0.67	4.33	13346	8964	0.67	4.63
	22	14945	8191	0.55	4.24	14637	8023	0.55	4.24	14268	7820	0.55	4.78
28	16	12177	12177	1.00	3.94	11808	11808	1.00	4.17	11439	11439	1.00	4.41
	18	13038	11582	0.89	4.02	12669	11254	0.89	4.24	12239	10872	0.89	4.53
	20	14022	10633	0.76	4.14	13715	10400	0.76	4.33	13346	10120	0.76	4.63
	22	14945	9451	0.63	4.24	14637	9257	0.63	4.24	14268	9023	0.63	4.78
30	16	12177	12177	1.00	3.94	11808	11808	1.00	4.17	11439	11439	1.00	4.41
	18	13038	12712	0.98	4.02	12669	12352	0.98	4.24	12239	11933	0.98	4.53
	20	14022	11849	0.84	4.14	13715	11589	0.84	4.33	13346	11277	0.84	4.63
	22	14945	10711	0.72	4.24	14637	10491	0.72	4.24	14268	10226	0.72	4.78
32	16	12177	12177	1.00	3.94	11808	11808	1.00	4.17	11439	11439	1.00	4.41
	18	13038	13038	1.00	4.02	12669	12669	1.00	4.24	12239	12239	1.00	4.53
	20	14022	13064	0.93	4.14	13715	12777	0.93	4.33	13346	12434	0.93	4.63
	22	14945	11971	0.80	4.24	14637	11725	0.80	4.24	14268	11430	0.80	4.78
34	16	12177	12177	1.00	3.94	11808	11808	1.00	4.17	11439	11439	1.00	4.41
	18	13038	13038	1.00	4.02	12669	12669	1.00	4.24	12239	12239	1.00	4.53
	20	14022	14022	1.00	4.14	13715	13715	1.00	4.33	13346	13346	1.00	4.63
	22	14945	13232	0.89	4.24	14637	12960	0.89	4.24	14268	12633	0.89	4.78

Indoor Intake air D.B. (°C)	Indoor Intake air W.B. (°C)	Outdoor intake air D.B. (°C)											
		35				40				45			
		CA	SHC(W)	SHF	P.C.	CA	SHC(W)	SHF	P.C.	CA	SHC(W)	SHF	P.C.
20	16	10947	7353	0.67	4.73	10455	7022	0.67	5.07	9963	6692	0.67	5.50
	18	11808	6396	0.54	4.86	11439	6196	0.54	5.23	10701	5796	0.54	5.62
	20	12792	5266	0.41	4.97	12300	5063	0.41	5.33	11562	4760	0.41	5.72
22	16	10947	8301	0.76	4.73	10455	7928	0.76	5.07	9963	7555	0.76	5.50
	18	11808	7419	0.63	4.86	11439	7187	0.63	5.23	10701	6724	0.63	5.62
	20	12792	6375	0.50	4.97	12300	6129	0.50	5.33	11562	5762	0.50	5.72
24	16	10947	9250	0.84	4.73	10455	8834	0.84	5.07	9963	8419	0.84	5.50
	18	11808	8443	0.71	4.86	11439	8179	0.71	5.23	10701	7651	0.71	5.62
	20	12792	7483	0.59	4.97	12300	7196	0.59	5.33	11562	6764	0.59	5.72
	22	13776	6389	0.46	5.08	13284	6161	0.46	5.48	12546	5819	0.46	5.81
26	16	10947	10199	0.93	4.73	10455	9741	0.93	5.07	9963	9282	0.93	5.50
	18	11808	9466	0.80	4.86	11439	9170	0.80	5.23	10701	8579	0.80	5.62
	20	12792	8592	0.67	4.97	12300	8261	0.67	5.33	11562	7766	0.67	5.72
	22	13776	7551	0.55	5.08	13284	7281	0.55	5.48	12546	6877	0.55	5.81
28	16	10947	10947	1.00	4.73	10455	10455	1.00	5.07	9963	9963	1.00	5.50
	18	11808	10489	0.89	4.86	11439	10162	0.89	5.23	10701	9506	0.89	5.62
	20	12792	9701	0.76	4.97	12300	9327	0.76	5.33	11562	8768	0.76	5.72
	22	13776	8712	0.63	5.08	13284	8401	0.63	5.48	12546	7934	0.63	5.81
30	16	10947	10947	1.00	4.73	10455	10455	1.00	5.07	9963	9963	1.00	5.50
	18	11808	11513	0.98	4.86	11439	11153	0.98	5.23	10701	10433	0.98	5.62
	20	12792	10809	0.84	4.97	12300	10393	0.84	5.33	11562	9770	0.84	5.72
	22	13776	9874	0.72	5.08	13284	9521	0.72	5.48	12546	8992	0.72	5.81
32	16	10947	10947	1.00	4.73	10455	10455	1.00	5.07	9963	9963	1.00	5.50
	18	11808	11808	1.00	4.86	11439	11439	1.00	5.23	10701	10701	1.00	5.62
	20	12792	11918	0.93	4.97	12300	11459	0.93	5.33	11562	10772	0.93	5.72
	22	13776	11035	0.80	5.08	13284	10641	0.80	5.48	12546	10050	0.80	5.81
34	16	10947	10947	1.00	4.73	10455	10455	1.00	5.07	9963	9963	1.00	5.50
	18	11808	11808	1.00	4.86	11439	11439	1.00	5.23	10701	10701	1.00	5.62
	20	12792	12792	1.00	4.97	12300	12300	1.00	5.33	11562	11562	1.00	5.72
	22	13776	12197	0.89	5.08	13284	11762	0.89	5.48	12546	11108	0.89	5.81

Notes CA: Capacity (W) SHC (W): Sensible heat capacity  
P.C.: Power consumption (kW) SHF: Sensible heat factor

PEHD-P6EAH/PEAD-P6EA

Indoor Intake air D.B. (°C)	Indoor Intake air W.B. (°C)	Outdoor intake air D.B. (°C)											
		20				25				30			
		CA	SHC(W)	SHF	P.C.	CA	SHC(W)	SHF	P.C.	CA	SHC(W)	SHF	P.C.
20	16	13959	8895	0.64	4.71	13536	8625	0.64	4.98	13113	8356	0.64	5.27
	18	14946	7681	0.51	4.81	14523	7463	0.51	5.07	14030	7210	0.51	5.43
	20	16074	6278	0.39	4.95	15722	6140	0.39	5.19	15299	5975	0.39	5.54
22	16	13959	10043	0.72	4.71	13536	9738	0.72	4.98	13113	9434	0.72	5.27
	18	14946	8909	0.60	4.81	14523	8657	0.60	5.07	14030	8363	0.60	5.43
	20	16074	7599	0.47	4.95	15722	7433	0.47	5.19	15299	7233	0.47	5.54
24	16	13959	11190	0.80	4.71	13536	10851	0.80	4.98	13113	10512	0.80	5.27
	18	14946	10138	0.68	4.81	14523	9851	0.68	5.07	14030	9517	0.68	5.43
	20	16074	8921	0.56	4.95	15722	8725	0.56	5.19	15299	8491	0.56	5.54
	22	17132	7538	0.44	5.08	16779	7383	0.44	5.08	16356	7197	0.44	5.72
26	16	13959	12338	0.88	4.71	13536	11964	0.88	4.98	13113	11590	0.88	5.27
	18	14946	11367	0.76	4.81	14523	11046	0.76	5.07	14030	10670	0.76	5.43
	20	16074	10243	0.64	4.95	15722	10018	0.64	5.19	15299	9749	0.64	5.54
	22	17132	8908	0.52	5.08	16779	8725	0.52	5.08	16356	8505	0.52	5.72
28	16	13959	13486	0.97	4.71	13536	13077	0.97	4.98	13113	12669	0.97	5.27
	18	14946	12596	0.84	4.81	14523	12240	0.84	5.07	14030	11824	0.84	5.43
	20	16074	11564	0.72	4.95	15722	11311	0.72	5.19	15299	11006	0.72	5.54
	22	17132	10279	0.60	5.08	16779	10067	0.60	5.08	16356	9813	0.60	5.72
30	16	13959	13959	1.00	4.71	13536	13536	1.00	4.98	13113	13113	1.00	5.27
	18	14946	13825	0.93	4.81	14523	13434	0.93	5.07	14030	12977	0.93	5.43
	20	16074	12886	0.80	4.95	15722	12603	0.80	5.19	15299	12264	0.80	5.54
	22	17132	11649	0.68	5.08	16779	11409	0.68	5.08	16356	11122	0.68	5.72
32	16	13959	13959	1.00	4.71	13536	13536	1.00	4.98	13113	13113	1.00	5.27
	18	14946	14946	1.00	4.81	14523	14523	1.00	5.07	14030	14030	1.00	5.43
	20	16074	14208	0.88	4.95	15722	13896	0.88	5.19	15299	13522	0.88	5.54
	22	17132	13020	0.76	5.08	16779	12752	0.76	5.08	16356	12430	0.76	5.72
34	16	13959	13959	1.00	4.71	13536	13536	1.00	4.98	13113	13113	1.00	5.27
	18	14946	14946	1.00	4.81	14523	14523	1.00	5.07	14030	14030	1.00	5.43
	20	16074	15529	0.97	4.95	15722	15189	0.97	5.19	15299	14780	0.97	5.54
	22	17132	14390	0.84	5.08	16779	14094	0.84	5.08	16356	13739	0.84	5.72

Indoor Intake air D.B. (°C)	Indoor Intake air W.B. (°C)	Outdoor intake air D.B. (°C)											
		35				40				45			
		CA	SHC(W)	SHF	P.C.	CA	SHC(W)	SHF	P.C.	CA	SHC(W)	SHF	P.C.
20	16	12549	7996	0.64	5.66	11985	7637	0.64	6.07	11421	7278	0.64	6.58
	18	13536	6956	0.51	5.82	13113	6739	0.51	6.26	12267	6304	0.51	6.73
	20	14664	5727	0.39	5.95	14100	5507	0.39	6.37	13254	5176	0.39	6.85
22	16	12549	9028	0.72	5.66	11985	8623	0.72	6.07	11421	8217	0.72	6.58
	18	13536	8069	0.60	5.82	13113	7817	0.60	6.26	12267	7312	0.60	6.73
	20	14664	6933	0.47	5.95	14100	6666	0.47	6.37	13254	6266	0.47	6.85
24	16	12549	10060	0.80	5.66	11985	9608	0.80	6.07	11421	9156	0.80	6.58
	18	13536	9182	0.68	5.82	13113	8895	0.68	6.26	12267	8321	0.68	6.73
	20	14664	8139	0.56	5.95	14100	7826	0.56	6.37	13254	7356	0.56	6.85
	22	15792	6949	0.44	6.08	15228	6700	0.44	6.56	14382	6328	0.44	6.96
26	16	12549	11092	0.88	5.66	11985	10593	0.88	6.07	11421	10095	0.88	6.58
	18	13536	10295	0.76	5.82	13113	9973	0.76	6.26	12267	9330	0.76	6.73
	20	14664	9344	0.64	5.95	14100	8985	0.64	6.37	13254	8446	0.64	6.85
	22	15792	8212	0.52	6.08	15228	7919	0.52	6.56	14382	7479	0.52	6.96
28	16	12549	12124	0.97	5.66	11985	11579	0.97	6.07	11421	11034	0.97	6.58
	18	13536	11408	0.84	5.82	13113	11051	0.84	6.26	12267	10338	0.84	6.73
	20	14664	10550	0.72	5.95	14100	10144	0.72	6.37	13254	9536	0.72	6.85
	22	15792	9475	0.60	6.08	15228	9137	0.60	6.56	14382	8629	0.60	6.96
30	16	12549	12549	1.00	5.66	11985	11985	1.00	6.07	11421	11421	1.00	6.58
	18	13536	12521	0.93	5.82	13113	12130	0.93	6.26	12267	11347	0.93	6.73
	20	14664	11756	0.80	5.95	14100	11303	0.80	6.37	13254	10625	0.80	6.85
	22	15792	10738	0.68	6.08	15228	10355	0.68	6.56	14382	9780	0.68	6.96
32	16	12549	12549	1.00	5.66	11985	11985	1.00	6.07	11421	11421	1.00	6.58
	18	13536	13536	1.00	5.82	13113	13113	1.00	6.26	12267	12267	1.00	6.73
	20	14664	12961	0.88	5.95	14100	12463	0.88	6.37	13254	11715	0.88	6.85
	22	15792	12002	0.76	6.08	15228	11573	0.76	6.56	14382	10930	0.76	6.96
34	16	12549	12549	1.00	5.66	11985	11985	1.00	6.07	11421	11421	1.00	6.58
	18	13536	13536	1.00	5.82	13113	13113	1.00	6.26	12267	12267	1.00	6.73
	20	14664	14167	0.97	5.95	14100	13622	0.97	6.37	13254	12805	0.97	6.85
	22	15792	13265	0.84	6.08	15228	12791	0.84	6.56	14382	12081	0.84	6.96

Notes CA: Capacity (W) SHC (W): Sensible heat capacity  
P.C.: Power consumption (kW) SHF: Sensible heat factor

### Cooling capacity correction factors

Service Ref.	Refrigerant piping length (one way)									
	5m	10m	15m	20m	25m	30m	35m	40m	45m	50m
PEHD-P1.6EAH PEAD-P1.6EA	1.00	0.993	0.984	0.978	0.969	0.961	0.956	0.948	–	–
PEHD-P2EAH PEAD-P2EA	1.00	0.993	0.984	0.978	0.969	0.961	0.956	0.948	–	–
PEHD-P2.5EAH PEAD-P2EA	1.00	0.989	0.980	0.970	0.960	0.950	0.940	0.930	0.920	0.910
PEHD-P3EAH PEAD-P3EA	1.00	0.981	0.968	0.952	0.940	0.925	0.913	0.900	0.886	0.874
PEHD-P4EAH PEAD-P4EA	1.00	0.989	0.980	0.970	0.960	0.950	0.940	0.930	0.920	0.910
PEHD-P5EAH PEAD-P5EA	1.00	0.981	0.968	0.952	0.940	0.925	0.913	0.900	0.886	0.874
PEHD-P6EAH PEAD-P6EA	1.00	0.975	0.955	0.935	0.918	0.900	0.884	0.869	0.855	0.840

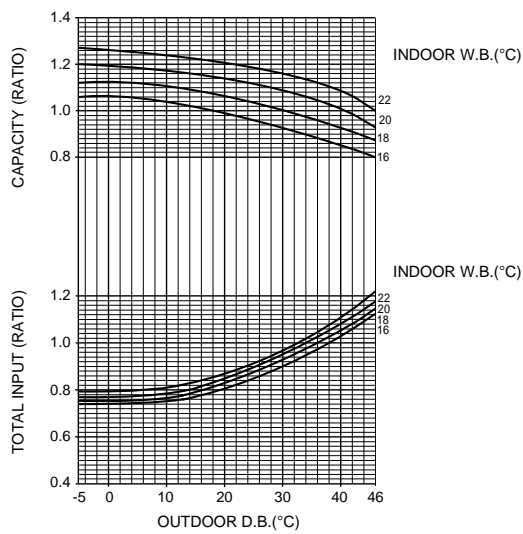

## 2) HEATING CAPACITY

Service.Ref	Indoor Intake air D.B°C	Outdoor Intake air W.B°C											
		-10		-5		0		5		10		15	
		CA	P.C.	CA	P.C.	CA	P.C.	CA	P.C.	CA	P.C.	CA	P.C.
PEDH-P1.6EAH PEAD-P1.6EA	15	3112	1.06	3381	1.17	3773	1.35	4949	1.62	5586	1.80	6223	1.94
	20	2989	1.16	3234	1.26	3577	1.45	4778	1.74	5390	1.94	6003	2.09
	25	2891	1.22	3136	1.37	3430	1.59	4508	1.86	5194	2.08	5782	2.24
PEDH-P2EAH PEAD-P2EA	15	3905	1.31	4244	1.45	4736	1.66	6212	2.00	7011	2.22	7811	2.39
	20	3752	1.42	4059	1.55	4490	1.80	5996	2.15	6765	2.39	7534	2.58
	25	3629	1.51	3936	1.69	4305	1.95	5658	2.29	6519	2.56	7257	2.76
PEDH-P2.5EAH PEAD-P2.5EA	15	4572	1.43	4968	1.57	5544	1.81	7272	2.18	8208	2.41	9144	2.61
	20	4392	1.54	4752	1.69	5256	1.96	7020	2.34	7920	2.61	8820	2.80
	25	4248	1.65	4608	1.84	5040	2.12	6624	2.49	7632	2.79	8496	3.01
PEDH-P3EAH PEAD-P3EA	15	5779	1.91	6279	2.11	7007	2.43	9191	2.92	10374	3.24	11557	3.50
	20	5551	2.07	6006	2.27	6643	2.62	8873	3.14	10010	3.50	11148	3.76
	25	5369	2.20	5824	2.46	6370	2.85	8372	3.34	9646	3.74	10738	4.03
PEDH-P4EAH PEAD-P4EA	15	6604	2.40	7176	2.65	8008	3.05	10504	3.66	11856	4.07	13208	4.40
	20	6344	2.60	6864	2.85	7592	3.30	10140	3.95	11440	4.40	12740	4.72
	25	6136	2.77	6656	3.09	7280	3.58	9568	4.19	11024	4.70	12272	5.07
PEDH-P5EAH PEAD-P5EA	15	8827	2.84	9591	3.13	10703	3.61	14039	4.33	15846	4.81	17653	5.19
	20	8479	3.07	9174	3.37	10147	3.90	13553	4.67	15290	5.19	17028	5.58
	25	8201	3.27	8896	3.66	9730	4.23	12788	4.96	14734	5.56	16402	5.99
PEDH-P6EAH PEAD-P6EA	15	10605	3.51	11523	3.87	12859	4.47	16867	5.36	19038	5.96	21209	6.44
	20	10187	3.81	11022	4.17	12191	4.83	16283	5.78	18370	6.44	20458	6.91
	25	9853	4.06	10688	4.53	11690	5.24	15364	6.14	17702	6.88	19706	7.42

Note CA: Capacity (W)  
P.C.: Power consumption (kW)

### Heating capacity correction factors

Service Ref.	Refrigerant piping length (one way)									
	5m	10m	15m	20m	25m	30m	35m	40m	45m	50m
PEHD-P1.6EAH PEAD-P1.6EA	1.00	0.998	0.995	0.993	0.990	0.988	0.985	0.983	-	-
PEHD-P2EAH PEAD-P2EA	1.00	0.998	0.995	0.993	0.990	0.988	0.985	0.983	-	-
PEHD-P2.5EAH PEAD-P2EA	1.00	0.998	0.995	0.993	0.990	0.988	0.985	0.983	0.980	0.978
PEHD-P3EAH PEAD-P3EA	1.00	0.998	0.995	0.993	0.990	0.988	0.985	0.983	0.980	0.978
PEHD-P4EAH PEAD-P4EA	1.00	0.998	0.995	0.993	0.990	0.988	0.985	0.983	0.980	0.978
PEHD-P5EAH PEAD-P5EA	1.00	0.998	0.995	0.993	0.990	0.988	0.985	0.983	0.980	0.978
PEHD-P6EAH PEAD-P6EA	1.00	0.998	0.995	0.993	0.990	0.988	0.985	0.983	0.980	0.978



# Heating

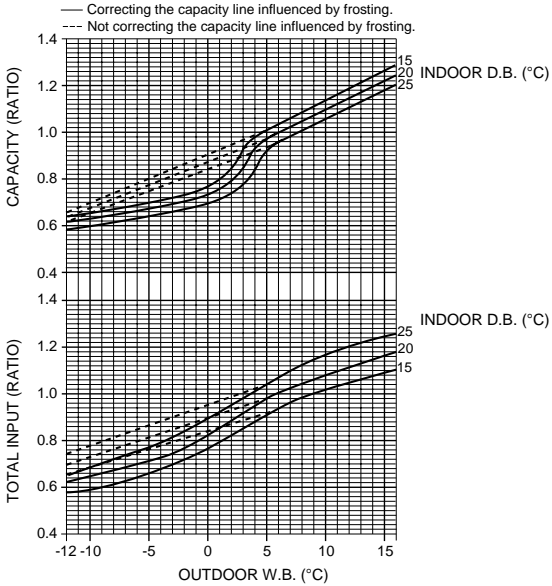

## 2 . FAN PERFORMANCE AND CORRECTED AIR FLOW

### PEHD-P1.6EAH, PEAD-P1.6EA

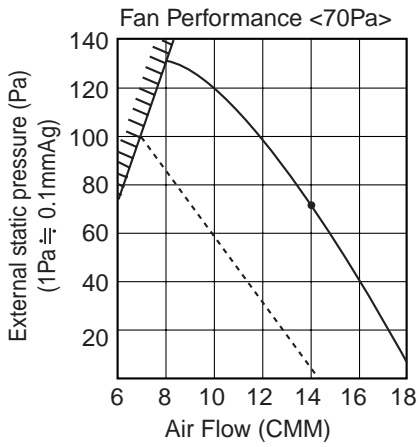
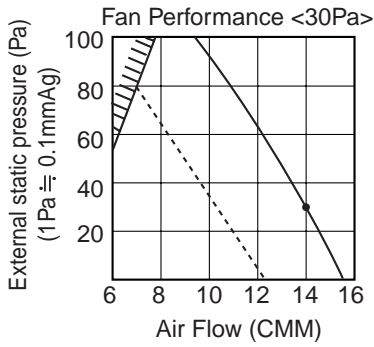

Corrected Air Flow — Capacity  
 ----- input

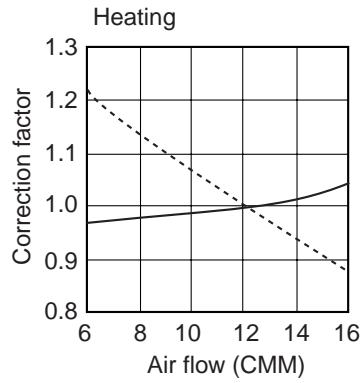
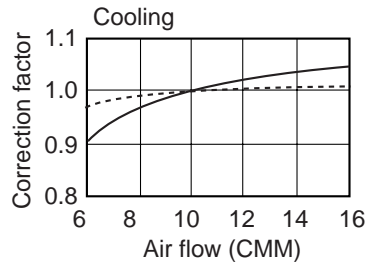

### PEHD-P2EAH, PEAD-P2EA

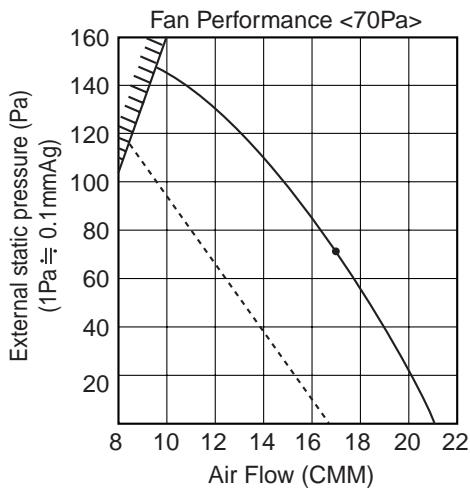
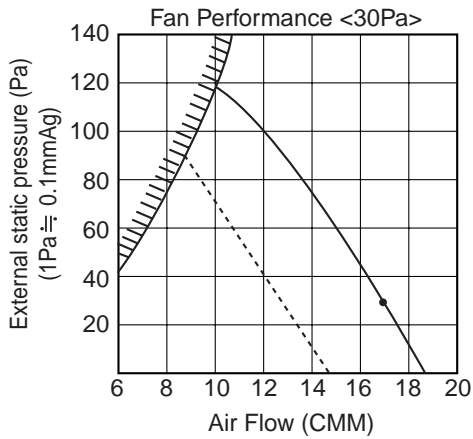

Corrected Air Flow — Capacity  
 ----- input

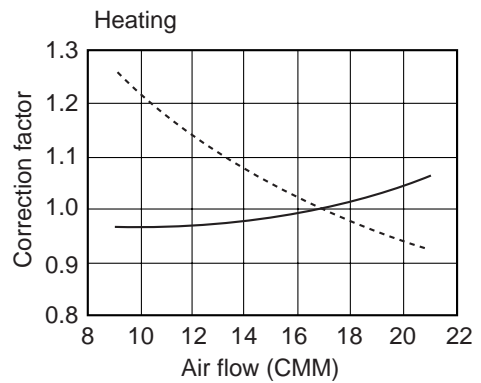
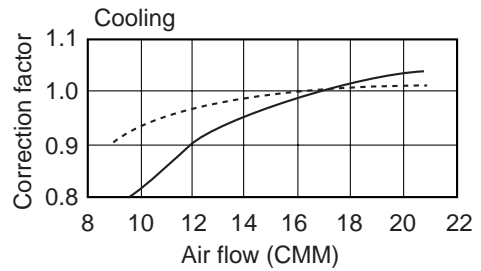

**PEHD-P2.5EAH, PEAD-P2.5EA**

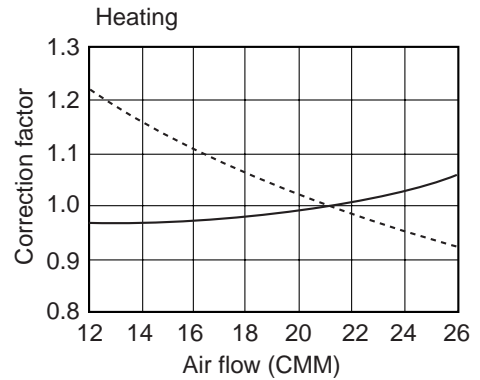
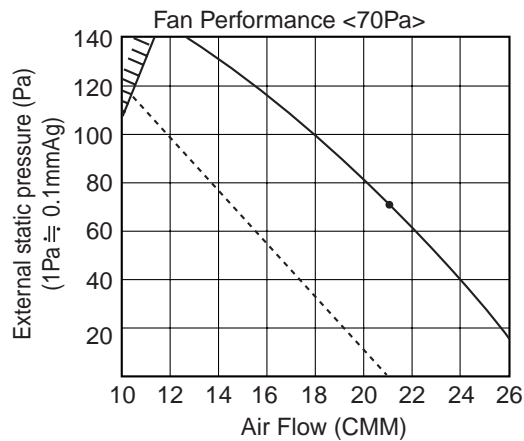
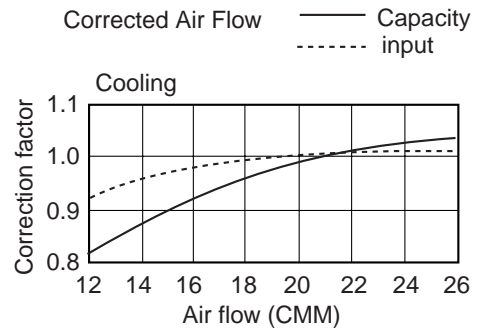
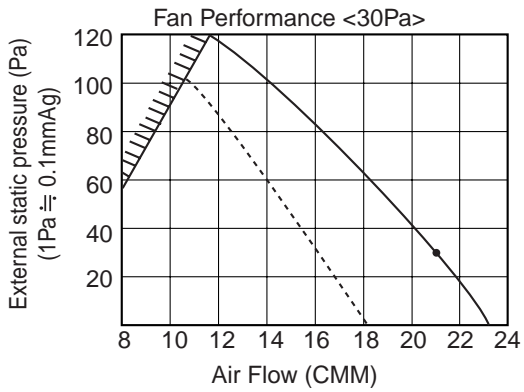

**PEHD-P3EAH, PEAD-P3EA**

Fan performance <130pa>

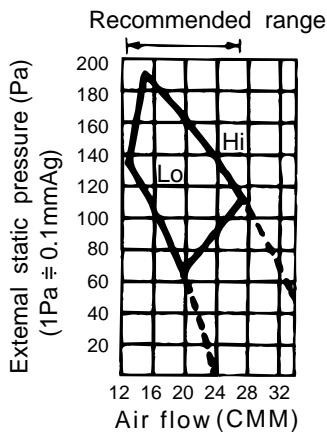

Fan performance <70pa>

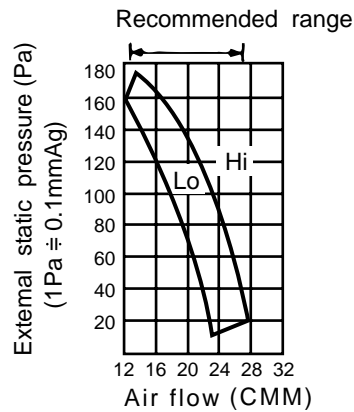

Corrected Air Flow

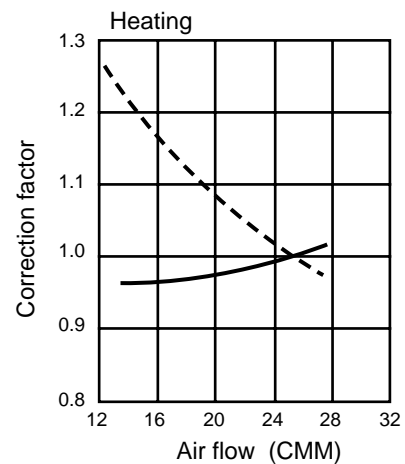
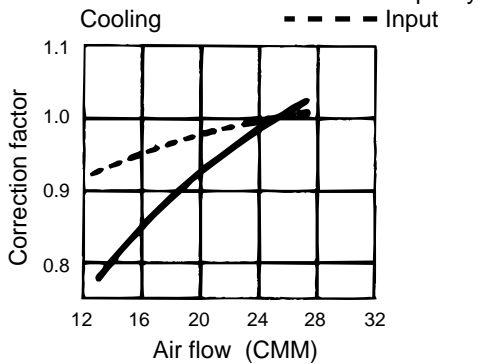

### PEHD-P4EAH, PEAD-P4EA

Fan performance <130pa>

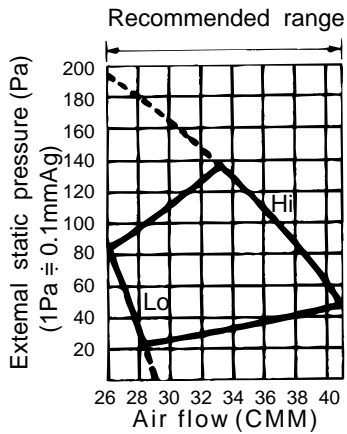

Fan performance <70pa>

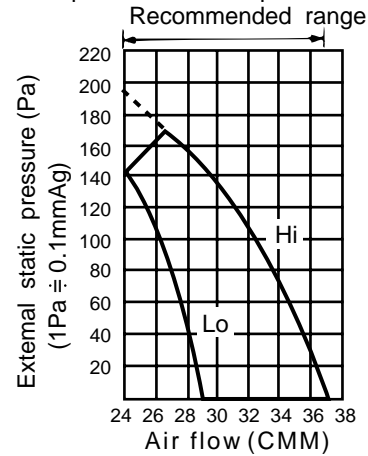

Corrected Air Flow

Cooling

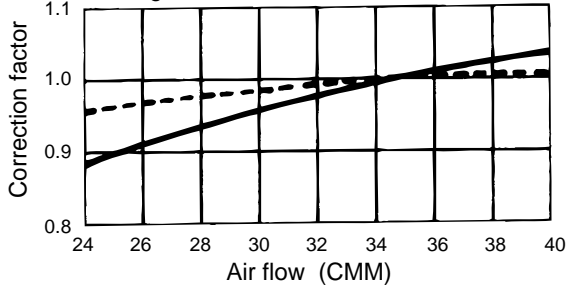

Heating

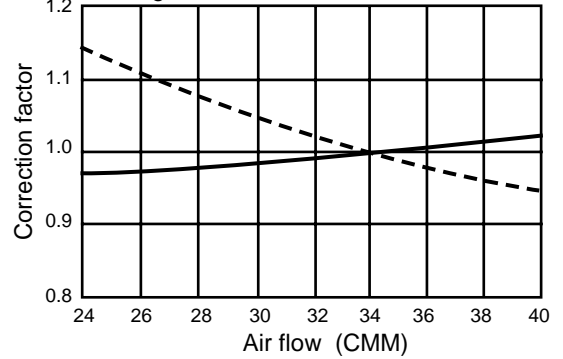

### PEHD- P5EAH, PEAD-P5EA

Fan performance <130pa>

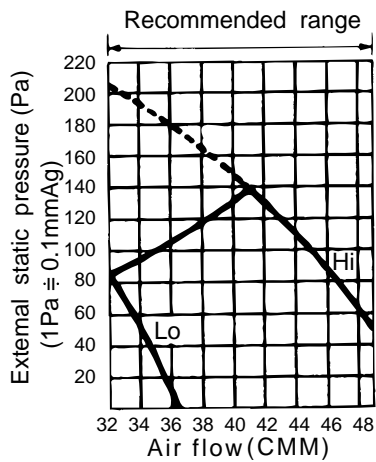

Fan performance <70pa>

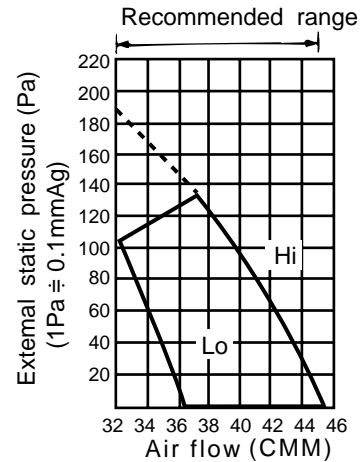

Corrected Air Flow

Cooling

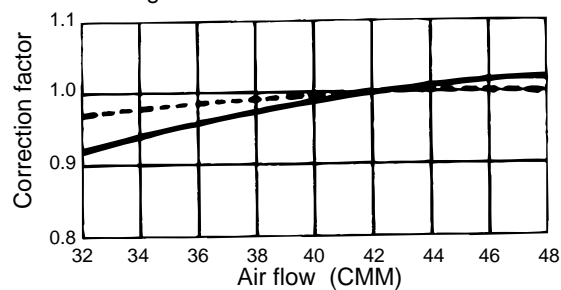

Heating

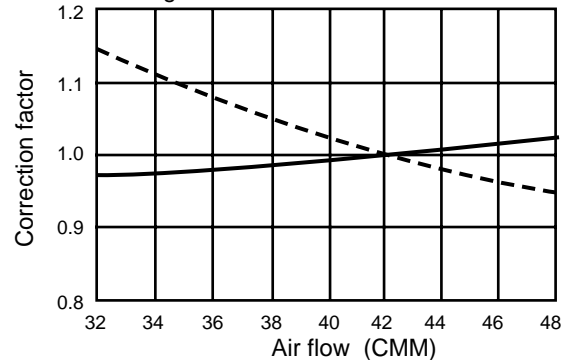

# PEHD-P6EAH, PEAD-P6EA

Fan performance <130pa>

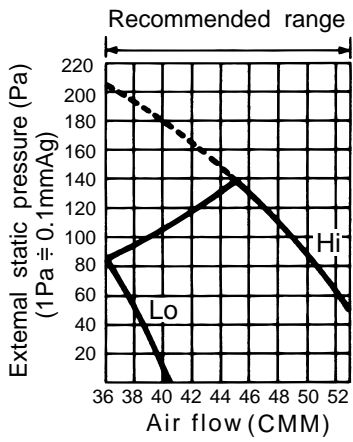

Fan performance <70pa>

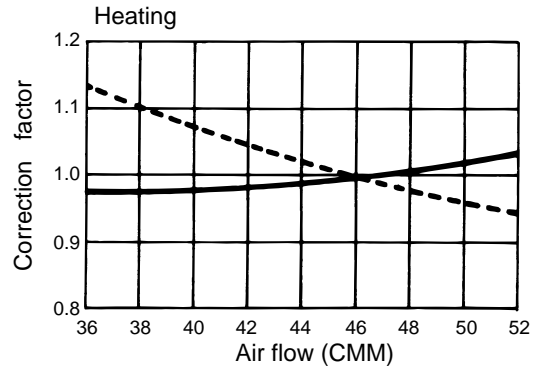
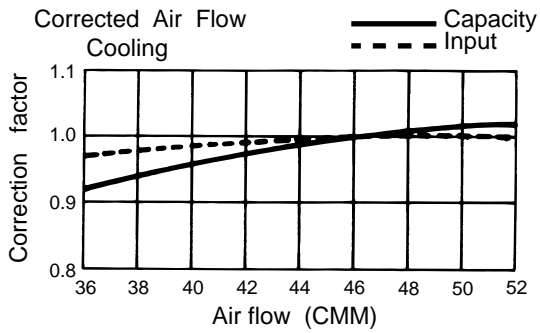
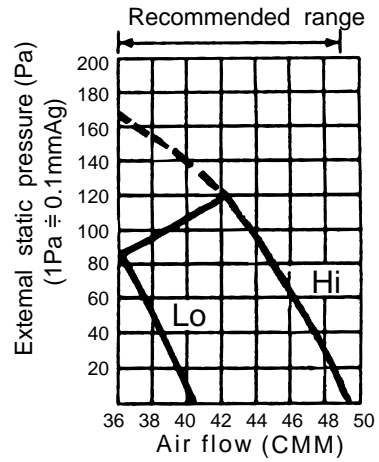

### 3. ELECTRICAL DATA

Heat pump type  
Rating Conditions (ISOT1)

Indoor .....220V 50Hz 1 phase Outdoor ..... 220V/380V 50Hz 1/3 phase

Service Ref.	Indoor unit	With heater	PEHD-P1.6EAH				PEHD-P2EAH				PEHD-P2.5EAH			
		Without heater	PEAD-P1.6EA				PEAD-P2EA				PEAD-P2.5EA			
	Outdoor unit	PUH-P1.6VGA	PUH-P1.6YGA	PUH-P2VGA	PUH-P2YGA	PUH-P2.5VGA1	PUH-P2.5YGA1							
Mode		Cooling	Heating	Cooling	Heating	Cooling	Heating	Cooling	Heating	Cooling	Heating	Cooling	Heating	
Capacity (W)		4400	4800 (5650)	4400	4800 (5650)	5450	6050 (6900)	5450	6050 (6900)	6500	7100 (8350)	6500	7100 (8350)	
Total input (kW)		1.66	1.66 (2.51)	1.66	1.66 (2.51)	2.34	2.11 (2.96)	2.34	2.11 (2.96)	2.61	2.35 (3.60)	2.61	2.35 (3.60)	
Indoor	Input (kW)	0.12	0.12 <0.85>	0.12	0.12 <0.85>	0.13	0.13 <0.85>	0.13	0.13 <0.85>	0.15	0.15 <1.25>	0.15	0.15 <1.25>	
	Current (A)	0.55	0.55 <3.86>	0.55	0.55 <3.86>	0.60	0.60 <3.86>	0.60	0.60 <3.86>	0.69	0.69 <5.67>	0.69	0.69 <5.67>	
	Starting current (A)	-	-	-	-	-	-	-	-	-	-	-	-	
Outdoor	Input (kW)	1.54	1.54	1.54	1.54	2.21	1.98	2.21	1.98	2.46	2.20	2.46	2.20	
	Current (A)	7.40	7.34	2.75	2.90	10.45	9.41	4.01	4.14	11.59	10.47	4.31	4.16	
	Starting current (A)	33	33	18	18	68	68	28	28	70	70	29	29	

Indoor .....230V 50Hz 1phase Outdoor ..... 230V/400V 50Hz 1/3 phase

Service Ref.	Indoor unit	With heater	PEHD-P1.6EAH				PEHD-P2EAH				PEHD-P2.5EAH			
		Without heater	PEAD-P1.6EA				PEAD-P2EA				PEAD-P2.5EA			
	Outdoor unit	PUH-P1.6VGA	PUH-P1.6YGA	PUH-P2VGA	PUH-P2YGA	PUH-P2.5VGA1	PUH-P2.5YGA1							
Mode		Cooling	Heating	Cooling	Heating	Cooling	Heating	Cooling	Heating	Cooling	Heating	Cooling	Heating	
Capacity (W)		4450	4850 (5750)	4450	4850 (5750)	5500	6100 (7000)	5500	6100 (7000)	6600	7150 (8550)	6600	7150 (8550)	
Total input (kW)		1.71	1.73 (2.63)	1.71	1.73 (2.63)	2.39	2.17 (3.07)	2.39	2.17 (3.07)	2.65	2.40 (3.80)	2.65	2.40 (3.80)	
Indoor	Input (kW)	0.13	0.13 <0.90>	0.13	0.13 <0.90>	0.14	0.14 <0.90>	0.14	0.14 <0.90>	0.16	0.16 <1.40>	0.16	0.16 <1.40>	
	Current (A)	0.55	0.55 <3.93>	0.55	0.55 <3.93>	0.61	0.61 <3.93>	0.61	0.61 <3.93>	0.70	0.70 <6.08>	0.70	0.70 <6.08>	
	Starting current (A)	-	-	-	-	-	-	-	-	-	-	-	-	
Outdoor	Input (kW)	1.58	1.60	1.58	1.60	2.25	2.03	2.25	2.03	2.49	2.24	2.49	2.24	
	Current (A)	7.42	7.36	2.71	2.85	10.38	9.34	3.91	4.06	11.32	10.38	4.19	4.07	
	Starting current (A)	35	35	19	19	71	71	29	29	74	74	31	31	

Indoor .....240V 50Hz 1 phase Outdoor ..... 240V/415V 50Hz 1/3 phase

Service Ref.	Indoor unit	With heater	PEHD-P1.6EAH				PEHD-P2EAH				PEHD-P2.5EAH			
		Without heater	PEAD-P1.6EA				PEAD-P2EA				PEAD-P2.5EA			
	Outdoor unit	PUH-P1.6VGA	PUH-P1.6YGA	PUH-P2VGA	PUH-P2YGA	PUH-P2.5VGA1	PUH-P2.5YGA1							
Mode		Cooling	Heating	Cooling	Heating	Cooling	Heating	Cooling	Heating	Cooling	Heating	Cooling	Heating	
Capacity (W)		4500	4900 (5900)	4500	4900 (5900)	5550	6150 (7150)	5550	6150 (7150)	6700	7200 (8700)	6700	7200 (8700)	
Total input (kW)		1.75	1.80 (2.80)	1.75	1.80 (2.80)	2.44	2.22 (3.22)	2.44	2.22 (3.22)	2.68	2.45 (3.95)	2.68	2.45 (3.95)	
Indoor	Input (kW)	0.13	0.13 <1.00>	0.13	0.13 <1.00>	0.15	0.15 <1.00>	0.15	0.15 <1.00>	0.17	0.17 <1.50>	0.17	0.17 <1.50>	
	Current (A)	0.55	0.55 <4.16>	0.55	0.55 <4.16>	0.63	0.63 <4.16>	0.63	0.63 <4.16>	0.72	0.72 <6.24>	0.72	0.72 <6.24>	
	Starting current (A)	-	-	-	-	-	-	-	-	-	-	-	-	
Outdoor	Input (kW)	1.62	1.67	1.62	1.67	2.29	2.07	2.29	2.07	2.51	2.28	2.51	2.28	
	Current (A)	7.43	7.43	2.67	2.86	10.39	9.36	3.88	4.02	11.27	10.32	4.11	4.03	
	Starting current (A)	36	36	20	20	74	74	30	30	77	77	32	32	

\*( ) shows the total rating.  
< > shows only the booster heater rating.

Indoor .....220V 50Hz 1 phase Outdoor ..... 220V/380V 50Hz 1/3 phase

Service Ref.	Indoor unit	With heater	PEHD-P3EAH				PEHD-P4EAH		PEHD-P5EAH		PEHD-P6EAH	
		Without heater	PEAD-P3EA				PEAD-P4EA		PEAD-P5EA		PEAD-P6EA	
	Outdoor unit		PUH-P3VGA		PUH-P3YGA		PUH-P4YGA		PUH-P5YGA		PUH-P6YGA	
Mode			Cooling	Heating	Cooling	Heating	Cooling	Heating	Cooling	Heating	Cooling	Heating
Capacity (W)			7500	9000 (10800)	7500	9000 (10800)	9500	10200 (12200)	12100	13700 (16200)	13900	16500 (19000)
Total input (kW)			3.29	3.12 (4.92)	3.29	3.12 (4.92)	3.76	3.93 (5.93)	4.81	4.68 (7.18)	5.72	5.84 (8.34)
Indoor	Input (kW)		0.30	0.30 <1.8>	0.30	0.30 <1.8>	0.52	0.52 <2.0>	0.54	0.54 <2.5>	0.56	0.56 <2.5>
	Current (A)		1.39	1.39 <8.16>	1.39	1.39 <8.16>	2.41	2.41 <9.04>	2.50	2.50 <11.32>	2.59	2.59 <11.32>
	Starting current (A)		-	-	-	-	-	-	-	-	-	-
Outdoor	Input (kW)		2.99	2.82	2.99	2.82	3.24	3.41	4.27	4.14	5.16	5.28
	Current (A)		14.71	13.91	5.54	5.84	5.55	5.86	8.92	9.29	10.72	10.94
	Starting current (A)		84	84	38	38	41	41	72	72	77	77

Indoor .....230V 50Hz 1 phase Outdoor ..... 230V/400V 50Hz 1/3 phase

Service Ref.	Indoor unit	With heater	PEHD-P3EAH				PEHD-P4EAH		PEHD-P5EAH		PEHD-P6EAH	
		Without heater	PEAD-P3EA				PEAD-P4EA		PEAD-P5EA		PEAD-P6EA	
	Outdoor unit		PUH-P3VGA		PUH-P3YGA		PUH-P4YGA		PUH-P5YGA		PUH-P6YGA	
Mode			Cooling	Heating	Cooling	Heating	Cooling	Heating	Cooling	Heating	Cooling	Heating
Capacity (W)			7600	9050 (10950)	7600	9050 (10950)	9600	10300 (12500)	12200	13800 (16500)	14000	16600 (19300)
Total input (kW)			3.35	3.18 (5.08)	3.35	3.18 (5.08)	3.83	4.00 (6.20)	4.87	4.74 (7.44)	5.81	5.90 (8.60)
Indoor	Input (kW)		0.35	0.35 <1.9>	0.35	0.35 <1.9>	0.57	0.57 <2.2>	0.59	0.59 <2.7>	0.61	0.61 <2.7>
	Current (A)		1.55	1.55 <8.23>	1.55	1.55 <8.23>	2.53	2.53 <9.51>	2.62	2.62 <11.68>	2.69	2.69 <11.68>
	Starting current (A)		-	-	-	-	-	-	-	-	-	-
Outdoor	Input (kW)		3.00	2.83	3.00	2.83	3.26	3.43	4.28	4.15	5.20	5.29
	Current (A)		14.09	13.33	5.46	5.75	5.48	5.78	8.59	8.95	10.36	10.53
	Starting current (A)		89	89	40	40	43	43	76	76	81	81

Indoor .....240V 50Hz 1 phase Outdoor ..... 240V/415V 50Hz 1/3 phase

Service Ref.	Indoor unit	With heater	PEHD-P3EAH				PEHD-P4EAH		PEHD-P5EAH		PEHD-P6EAH	
		Without heater	PEAD-P3EA				PEAD-P4EA		PEAD-P5EA		PEAD-P6EA	
	Outdoor unit		PUH-P3VGA		PUH-P3YGA		PUH-P4YGA		PUH-P5YGA		PUH-P6YGA	
Mode			Cooling	Heating	Cooling	Heating	Cooling	Heating	Cooling	Heating	Cooling	Heating
Capacity (W)			7700	9100 (11200)	7700	9100 (11200)	9700	10400 (12800)	12300	13900 (16900)	14100	16700 (19700)
Total input (kW)			3.41	3.24 (5.34)	3.41	3.24 (5.34)	3.90	4.07 (6.47)	4.93	4.81 (7.81)	5.90	5.96 (8.96)
Indoor	Input (kW)		0.40	0.40 <2.1>	0.40	0.40 <2.1>	0.62	0.62 <2.4>	0.64	0.64 <3.0>	0.66	0.66 <3.0>
	Current (A)		1.70	1.70 <8.71>	1.70	1.70 <8.71>	2.64	2.64 <9.94>	2.72	2.72 <12.45>	2.79	2.79 <12.45>
	Starting current (A)		-	-	-	-	-	-	-	-	-	-
Outdoor	Input (kW)		3.01	2.84	3.01	2.84	3.28	3.45	4.29	4.17	5.24	5.30
	Current (A)		13.73	13.12	5.46	5.76	5.49	5.79	8.39	8.74	10.17	10.28
	Starting current (A)		93	93	41	41	45	45	79	79	84	84

\*( ) shows the total rating.  
< > shows only the booster heater rating.

Cooling only type  
Rating Conditions (ISOT1)

Indoor ..... 220V 50Hz 1 phase Outdoor.....220V/380V 50Hz 1/3 phase

Service Ref.	Indoor unit	PEAD-P1.6EA	PEAD-P2EA	PEAD-P2.5EA	PEAD-P3EA		PEAD-P4EA	PEAD-P5EA	PEAD-P6EA
	Outdoor unit	PU-P1.6VGA	PU-P2VGA	PU-P2.5VGA1	PU-P3VGA	PU-P3YGA	PU-P4YGA	PU-P5YGA	PU-P6YGA
Mode		Cooling	Cooling	Cooling	Cooling	Cooling	Cooling	Cooling	Cooling
Capacity (W)		4400	5450	6500	7500	7500	9500	12100	13900
Total input (kW)		1.66	2.34	2.61	3.29	3.29	3.76	4.81	5.72
Indoor	Input (kW)	0.12	0.13	0.15	0.30	0.30	0.52	0.54	0.56
	Current (A)	0.55	0.60	0.69	1.39	1.39	2.41	2.50	2.59
	Starting current (A)	–	–	–	–	–	–	–	–
Outdoor	Input (kW)	1.54	2.21	2.46	2.99	2.99	3.24	4.27	5.16
	Current (A)	7.40	10.45	11.59	14.71	5.54	5.55	8.92	10.72
	Starting current (A)	33	68	70	84	38	41	72	77

Indoor ..... 230V 50Hz 1 phase Outdoor.....230V/400V 50Hz 1/3 phase

Service Ref.	Indoor unit	PEAD-P1.6EA	PEAD-P2EA	PEAD-P2.5EA	PEAD-P3EA		PEAD-P4EA	PEAD-P5EA	PEAD-P6EA
	Outdoor unit	PU-P1.6VGA	PU-P2VGA	PU-P2.5VGA1	PU-P3VGA	PU-P3YGA	PU-P4YGA	PU-P5YGA	PU-P6YGA
Mode		Cooling	Cooling	Cooling	Cooling	Cooling	Cooling	Cooling	Cooling
Capacity (W)		4450	5500	6600	7600	7600	9600	12200	14000
Total input (kW)		1.71	2.39	2.65	3.35	3.35	3.83	4.87	5.81
Indoor	Input (kW)	0.13	0.14	0.16	0.35	0.35	0.57	0.59	0.61
	Current (A)	0.55	0.61	0.70	1.55	1.55	2.53	2.62	2.69
	Starting current (A)	–	–	–	–	–	–	–	–
Outdoor	Input (kW)	1.58	2.25	2.49	3.00	3.00	3.26	4.28	5.20
	Current (A)	7.42	10.38	11.32	14.09	5.46	5.48	8.59	10.36
	Starting current (A)	35	71	74	89	40	43	76	81

Indoor ..... 240V 50Hz 1 phase Outdoor.....240V/415V 50Hz 1/3 phase

Service Ref.	Indoor unit	PEAD-P1.6EA	PEAD-P2EA	PEAD-P2.5EA	PEAD-P3EA		PEAD-P4EA	PEAD-P5EA	PEAD-P6EA
	Outdoor unit	PU-P1.6VGA	PU-P2VGA	PU-P2.5VGA1	PU-P3VGA	PU-P3YGA	PU-P4YGA	PU-P5YGA	PU-P6YGA
Mode		Cooling	Cooling	Cooling	Cooling	Cooling	Cooling	Cooling	Cooling
Capacity (W)		4500	5550	6700	7700	7700	9700	12300	14100
Total input (kW)		1.75	2.44	2.68	3.41	3.41	3.90	4.93	5.90
Indoor	Input (kW)	0.13	0.15	0.17	0.40	0.40	0.62	0.64	0.66
	Current (A)	0.55	0.63	0.72	1.70	1.70	2.64	2.72	2.79
	Starting current (A)	–	–	–	–	–	–	–	–
Outdoor	Input (kW)	1.62	2.29	2.51	3.01	3.01	3.28	4.29	5.24
	Current (A)	7.43	10.39	11.27	13.73	5.46	5.49	8.39	10.17
	Starting current (A)	36	74	77	93	41	45	79	84



#### 4. STANDARD OPERATION DATA

Heat pump type Rating Conditions (ISO T1)

Service Ref.		With Electric heater	PEHD-P1.6EAH		PEHD-P2EAH		PEHD-P2.5EAH		
		Without Electric heater	PEAD-P1.6EA		PEAD-P2EA		PEAD-P2EA		
Mode			Cooling	Heating	Cooling	Heating	Cooling	Heating	
Total	Capacity	W	4,500	4,900	5,550	6,150	6,700	7,200	
	Input	kW	1.75	1.80	2.44	2.22	2.68	2.45	
Electrical circuit	Indoor unit Service Ref.	With Electric heater	PEHD-P1.6EAH		PEHD-P2EAH		PEHD-P2.5EAH		
		Without Electric heater	PEAD-P1.6EA		PEAD-P2EA		PEAD-P2EA		
	Phase, Hz		1, 50		1, 50		1, 50		
	Volts	V	240		240		240		
	Amperes	A	0.55	0.55	0.63	0.63	0.72	0.72	
	Outdoor unit Service Ref.		PUH-P1.6VGA/YGA		PUH-P2VGA/YGA		PUH-P2.5VGA <sub>1</sub> /YGA <sub>1</sub>		
	Phase, Hz		1/3, 50		1/3, 50		1/3, 50		
	Volts	V	240/415		240/415		240/415		
Amperes	A	7.43/2.67	7.43/2.86	10.39/3.88	9.36/4.02	11.27/4.11	10.32/4.03		
Refrigerant circuit	Discharge pressure	MPa (kgf/cm <sup>2</sup> )	2.02 (20.6)	2.02 (20.6)	2.35 (24.0)	2.37 (24.2)	2.16 (22.0)	2.14 (21.8)	
	Suction pressure	MPa (kgf/cm <sup>2</sup> )	0.50 (5.1)	0.43 (4.4)	0.51 (5.2)	0.41 (4.2)	0.52 (5.3)	0.40 (4.1)	
	Discharge temperature	°C	78.5	76.9	85.3	83.2	78.5	76.1	
	Condensing temperature	°C	52.4	—	55.2	—	49.6	—	
	Suction temperature	°C	8.1	-0.3	7.0	-1.2	8.3	-1.3	
	Ref. pipe length	m	5	5	5	5	5	5	
Indoor side	Intake air temperature	D.B.	°C	27	20	27	20	27	20
		W.B.	°C	19	15	19	15	19	15
	Discharge air temperature	D.B.	°C	14.0	38.1	13.6	39.6	13.8	39.1
Outdoor side	Intake air temperature	D.B.	°C	35	7	35	7	35	7
		W.B.	°C	24	6	24	6	24	6
SHF			0.72	—	0.74	—	0.71	—	
BF			0.21	—	0.19	—	0.19	—	

The unit of pressure has been changed to Mpa based on international SI system.

The conversion factor is : 1 (Mpa) = 10.2 (kgf/cm<sup>2</sup>)

Service Ref.		With Electric heater		PEHD-P3EAH		PEHD-P4EAH		PEHD-P5EAH		PEHD-P6EAH	
		Without Electric heater		PEAD-P3EA		PEAD-P4EA		PEAD-P5EA		PEAD-P6EA	
Mode				Cooling	Heating	Cooling	Heating	Cooling	Heating	Cooling	Heating
Total	Capacity	W	7,700	9,100 (11,200)	9,700	10,400 (12,800)	12,300	13,900 (16,900)	14,100	16,700 (19,700)	
	Input	kW	3.41	3.24 (5.34)	3.90	4.07 (6.47)	4.93	4.81 (7.81)	5.9	5.96 (8.96)	
Electrical circuit	Indoor unit Service Ref.	With Electric heater		PEHD-P3EAH		PEHD-P4EAH		PEHD-P5EAH		PEHD-P6EAH	
		Without Electric heater		PEAD-P3EA		PEAD-P4EA		PEAD-P5EA		PEAD-P6EA	
	Phase, Hz			1, 50		1, 50		1, 50		1, 50	
	Volts		V	240		240		240		240	
	Amperes		A	1.70	1.70	2.64	2.64	2.72	2.72	2.79	2.79
	Outdoor unit Service Ref.			PUH-P3VGA PUH-P3YGA		PUH-P4YGA		PUH-P5YGA		PUH-P6YGA	
	Phase, Hz			1/3, 50		3, 50		3, 50		3, 50	
	Volts		V	240/415		415		415		415	
	Amperes		A	13.73/5.46	13.12/5.76	5.49	5.79	8.39	8.74	10.17	10.28
Refrigerant circuit	Discharge pressure		MPa (kgf/cm <sup>2</sup> )	2.20 (22.4)	2.10 (21.4)	2.07 (21.1)	2.26 (23.1)	2.03 (20.7)	2.31 (23.6)	2.09 (21.3)	2.11 (21.5)
	Suction pressure		MPa (kgf/cm <sup>2</sup> )	0.45 (4.6)	0.39 (4.0)	0.51 (5.2)	0.41 (4.2)	0.46 (4.7)	0.44 (4.5)	0.46 (4.7)	0.42 (4.3)
	Discharge temperature		°C	81.4	80.0	77.5	81.1	77.4	76.1	77.7	75.9
	Condensing temperature		°C	51.3	—	48.9	—	48.2	—	47.7	—
	Suction temperature		°C	6.3	-1.1	6.9	-0.5	4.8	-0.1	3.5	-1.9
	Ref. pipe length		m	5	5	5	5	5	5	5	5
Indoor side	Intake air temperature	D.B.	°C	27	20	27	20	27	20	27	20
		W.B.	°C	19	15	19	15	19	15	19	15
	Discharge air temperature	D.B.	°C	14.1	38.6	14.6	39.0	13.9	39.0	13.8	40.5
Outdoor side	Intake air temperature	D.B.	°C	35	7	35	7	35	7	35	7
		W.B.	°C	24	6	24	6	24	6	24	6
SHF			0.78	—	0.75	—	0.78	—	0.74	—	
BF			0.20	—	0.22	—	0.13	—	0.11	—	

The unit of pressure has been changed to Mpa based on international SI system.  
The conversion factor is : 1 (Mpa) = 10.2 (kgf/cm<sup>2</sup>)

Cooling only type Rating Conditions (ISO T1)

Service Ref.			PEAD-P1.6EA	PEAD-P2EA	PEAD-P2.5EA
Mode			Cooling	Cooling	Cooling
Total	Capacity	W	4,500	5,550	6,700
	Input	kW	1.75	2.44	2.68
Electrical circuit	Indoor unit Service Ref.		PEAD-P1.6EA	PEAD-P2EA	PEAD-P2.5EA
	Phase,Hz		1 , 50	1 , 50	1 , 50
	Volts	V	240	240	240
	Amperes	A	0.55	0.63	0.72
	Outdoor unit Service Ref.		PU-P1.6VGA	PU-P2VGA	PU-P2.5VGA <sub>1</sub>
	Phase,Hz		1 , 50	1 , 50	1 , 50
	Volts	V	240	240	240
	Amperes	A	7.43	10.39	11.27
Refrigerant circuit	Discharge pressure	MPa (kgf/cm <sup>2</sup> )	2.02 (20.6)	2.35 (24.0)	2.16 (22.0)
	Suction pressure	MPa (kgf/cm <sup>2</sup> )	0.50 (5.1)	0.51 (5.2)	0.52 (5.3)
	Discharge temperature	°C	78.5	85.3	78.5
	Condensing temperature	°C	52.4	55.2	49.6
	Suction temperature	°C	8.1	7.0	8.3
	Ref. pipe length	m	5	5	5
Indoor side	Intake air temperature	D.B.	°C	27	27
		W.B.	°C	19	19
	Discharge air temperature	D.B.	°C	14.0	13.6
Outdoor side	Intake air temperature	D.B.	°C	35	35
		W.B.	°C	24	24
SHF			0.72	0.74	0.71
BF			0.21	0.19	0.19

The unit of pressure has been changed to Mpa based on international SI system.  
The conversion factor is : 1 (Mpa) = 10.2 (kgf/cm<sup>2</sup>)

Service Ref.			PEAD-P3EA	PEAD-P4EA	PEAD-P5EA	PEAD-P6EA
Mode			Cooling	Cooling	Cooling	Cooling
Total	Capacity	W	7,700	9,700	12,300	14,100
	Input	kW	3.41	3.90	4.93	5.90
Electrical circuit	Indoor unit Service Ref.		PEAD-P3EA	PEAD-P4EA	PEAD-P5EA	PEAD-P6EA
	Phase,Hz		1 , 50	1 , 50	1 , 50	1 , 50
	Volts	V	240	240	240	240
	Amperes	A	1.70	2.64	2.72	2.79
	Outdoor unit Service Ref.		PU-P3VGA	PU-P4YGA	PU-P5YGA	PU-P6YGA
	Phase,Hz		1/3 , 50	3 , 50	3 , 50	3 , 50
	Volts	V	240/415	415	415	415
	Amperes	A	13.73/5.46	5.49	8.39	10.17
Refrigerant circuit	Discharge pressure		2.20 (22.4)	2.07 (21.1)	2.03 (20.7)	2.09 (21.3)
	Suction pressure		0.45 (4.6)	0.51 (5.2)	0.46 (4.7)	0.46 (4.7)
	Discharge temperature		°C 81.4	77.5	77.4	77.7
	Condensing temperature		°C 51.3	48.9	48.2	47.7
	Suction temperature		°C 6.3	6.9	4.8	3.5
	Ref. pipe length		m 5	5	5	5
Indoor side	Intake air temperature	D.B.	°C 27	27	27	27
		W.B.	°C 19	19	19	19
	Discharge air temperature	D.B.	°C 14.1	14.6	13.9	13.8
Outdoor side	Intake air temperature	D.B.	°C 35	35	35	35
		W.B.	°C 24	24	24	24
SHF			0.78	0.75	0.78	0.74
BF			0.20	0.22	0.13	0.11

The unit of pressure has been changed to Mpa based on international SI system.  
The conversion factor is : 1 (Mpa) = 10.2 (kgf/cm<sup>2</sup>)

# 6 REFRIGERANT SYSTEM DIAGRAM

PEHD-P1.6, 2, 2.5, 3, 4, 5, 6EAH

PEAD-P1.6, 2, 2.5, 3, 4, 5, 6EA

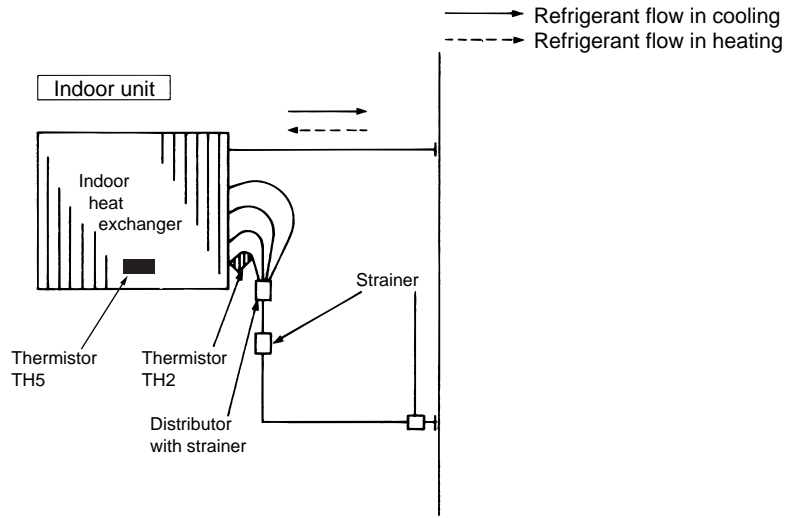

# 7

# OUTLINES & DIMENSIONS

## 1. INDOOR UNIT

PEHD-P1.6, 2, 2.5EAH

PEAD-P1.6, 2, 2.5EA

Model	A	B	C	D	E
P1.6,2	772	305	-	830	804
P2.5	1012	280	290	1070	1044

- ① Refrigerant piping flare connection (liquid  $\phi 9.52$  copper tube):HP
- ② Refrigerant piping flare connection (gas  $\phi 15.88$  copper tube):LP
- ③ Drain R1(External thread)
- ④ Electrical parts box
- ⑤ Electric Heater ... Only PEHD-P-EAH Type
- ⑥ Drain Pump (Option)
- ⑦ Drain Pipe (Option) ... Flexible joint VP-25(I.D. $\phi 32$ ) Set
- ⑧ Filter

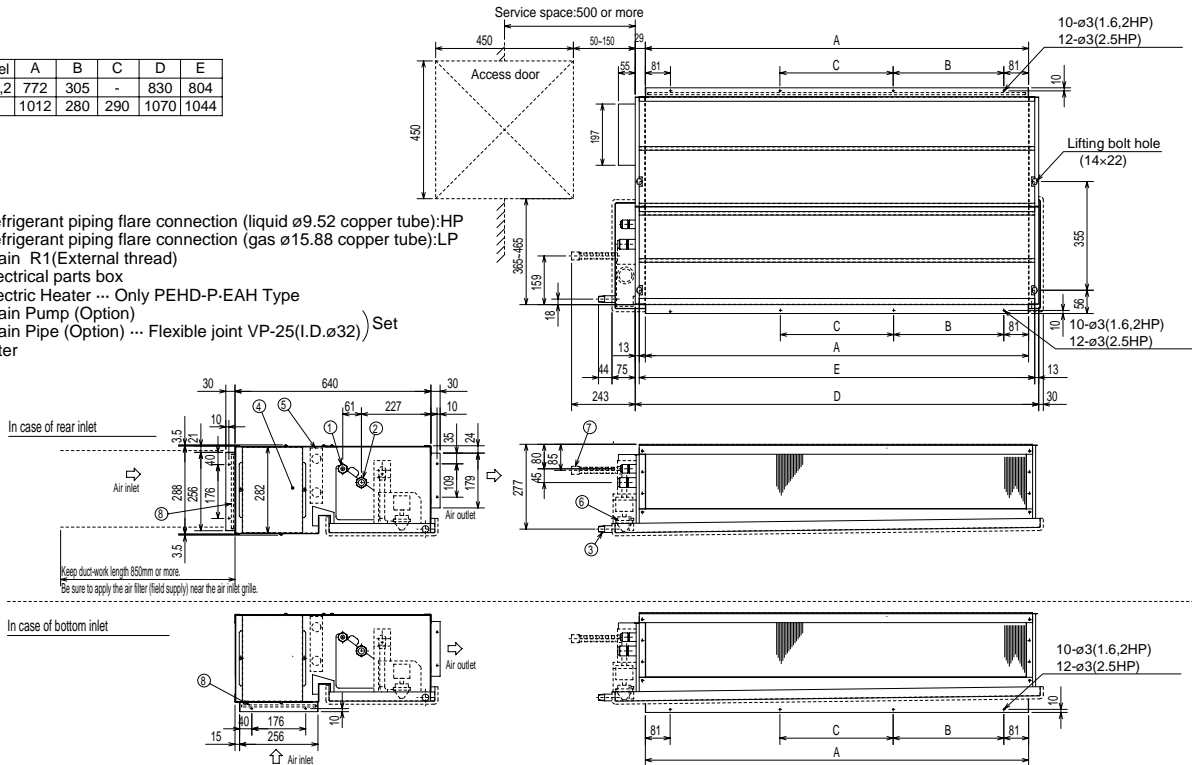

PEHD-P3, 4, 5, 6EAH

PEAD-P3, 4, 5, 6EA

Model	A	B	C	D	E	F
P3	1012	280	290	1070	1044	15.88
P4-5	1252	360	370	1310	1284	19.05
P6	1552	460	470	1610	1584	19.05

- ① Refrigerant piping flare connection (liquid  $\phi 9.52$  copper tube):HP
- ② Refrigerant piping flare connection (gas  $\phi F$  copper tube):LP
- ③ Drain 25A (male screw)
- ④ Electrical parts box
- ⑤ Electric Heater ... Only PEHD-P-EAH Type
- ⑥ Drain Pump (Option)
- ⑦ Drain Pipe (Option) ... Flexible joint VP25(I.D. $\phi 32$ ) Set
- ⑧ Filter

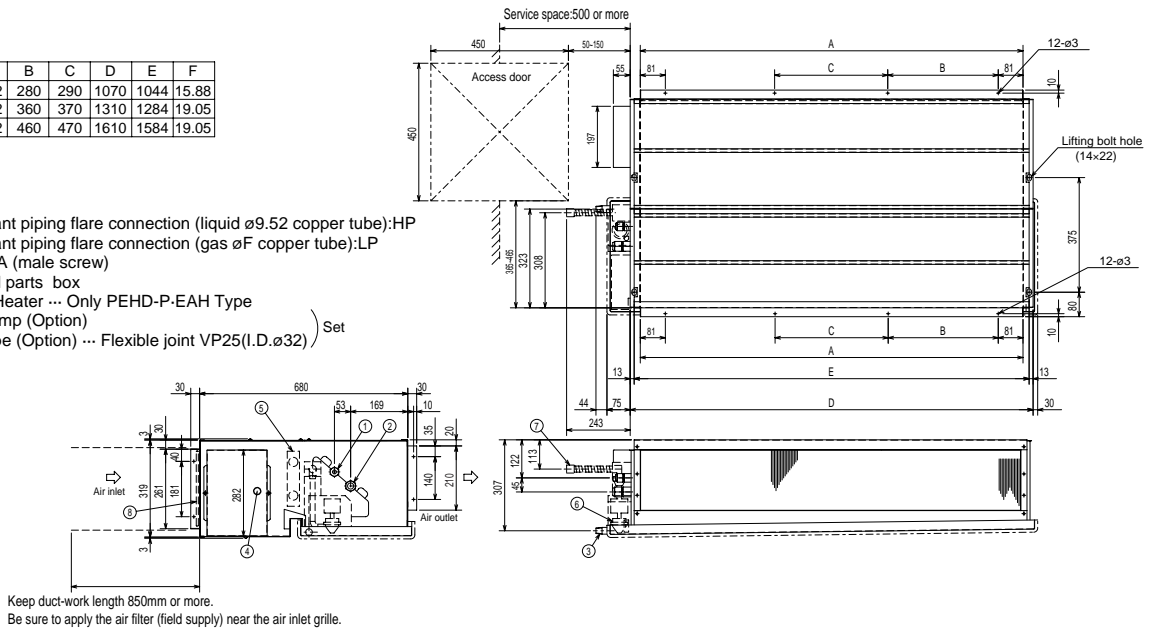

**2. REMOTE CONTROLLER**

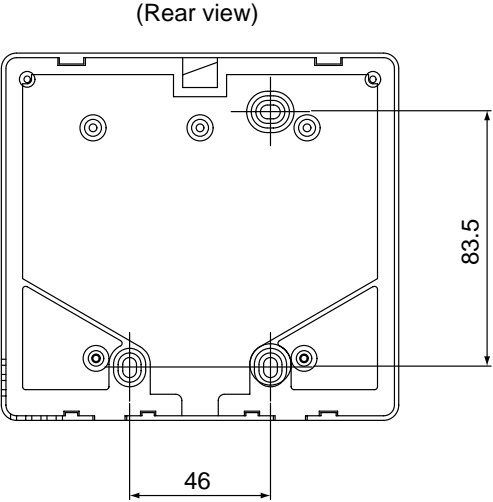
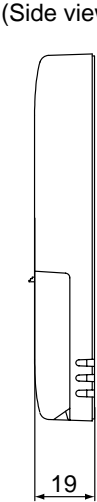
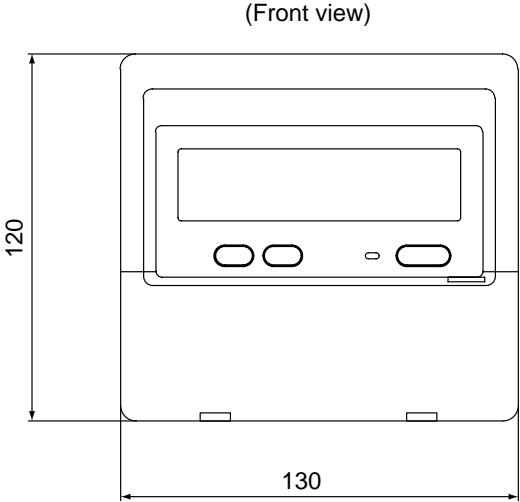

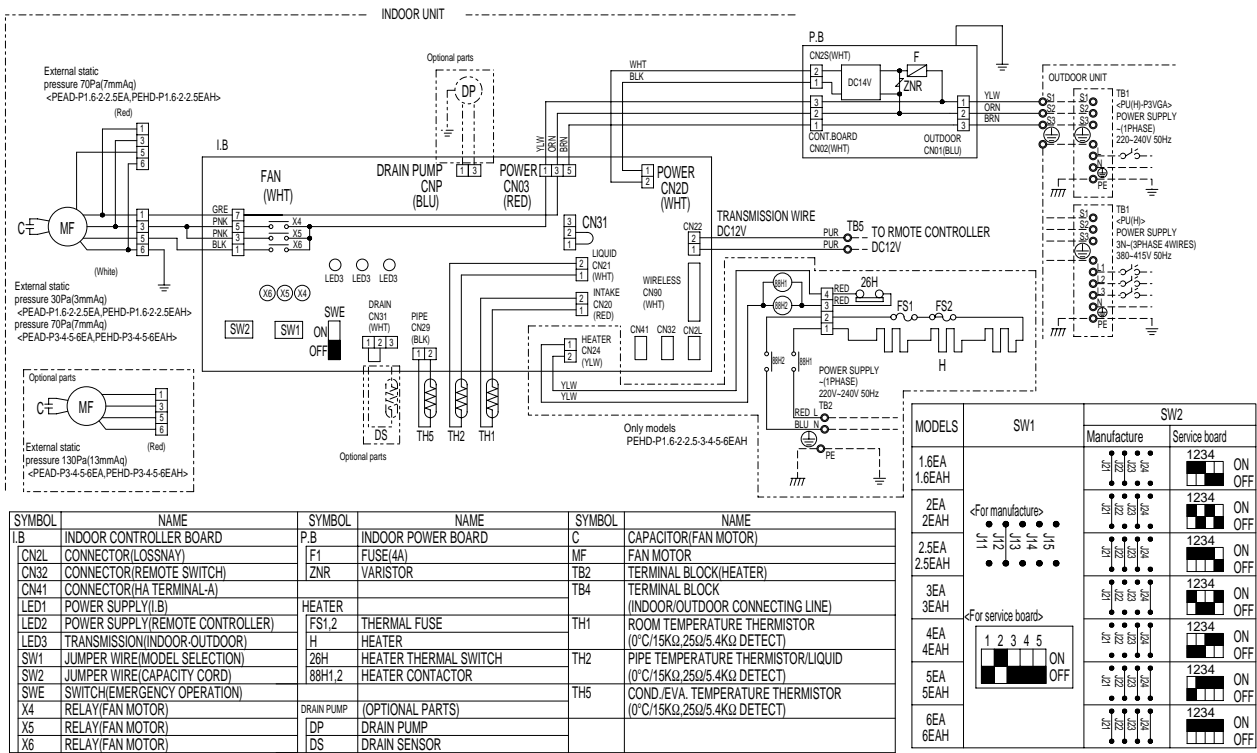
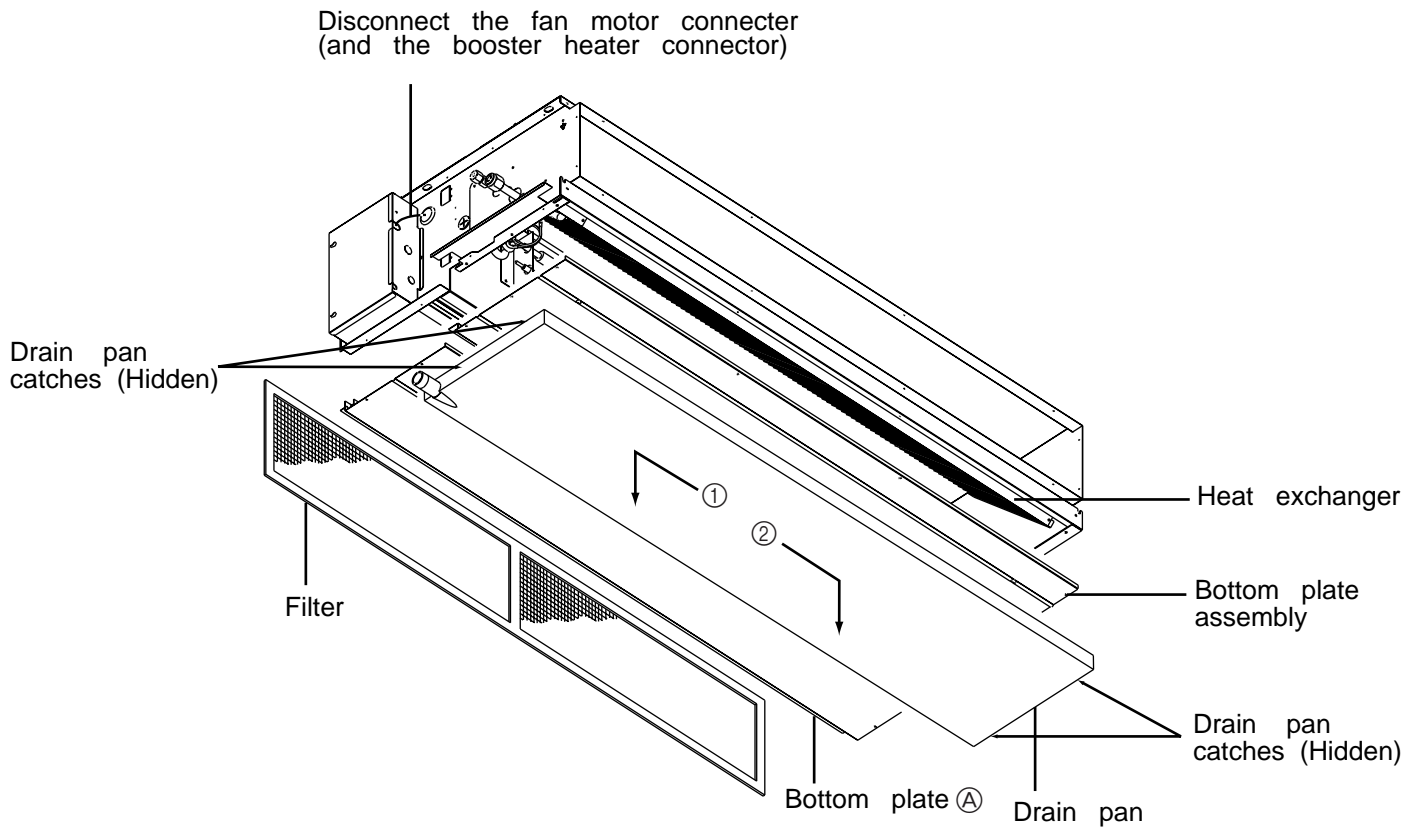



Figure1.



### I . Removing the fan motor

1. Removing the 9 screws that fix the bottom plate ①, and remove it.
2. Removing the drain pan as follows:
  - (1) Remove the screw that fix the drain pan.
  - (2) Slide the drain pan in the direction ①, Figure1 and unhook the drain pan catch near the drain pipe.
  - (3) Slide the drain pan in the direction ②, Figure1 and unhook the 2 catches on the other side of the drain pipe.
3. Remove the 8 screws that fix the bottom plate assembly, and remove it.
4. Disconnect the fan motor connector from the controller box.  
(For the models with booster heater, disconnect the booster heater connector as well.)

5. Remove the fan base plate as follow:

Figure2.

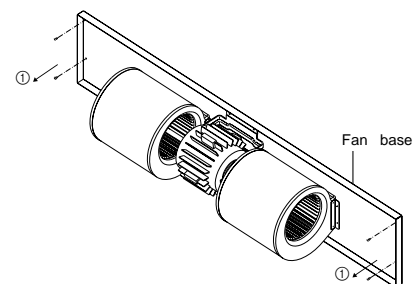

- (1) Remove the 4 screws①
- (2) Slide down the fan base plate to remove.

6. Removal of the fan motor:
  - (1) Remove the Sirocco fan securing screw (one screw each fan)
  - (2) Remove fan housing screws (four screws each housing)
  - (3) Remove motor base bracket (four screws)
  - (4) Remove motor from motor base bracket by the two screws (one on each motor rubber mounting clamp)
  - (5) Remove the fan and housing from the motor shaft (slide away from the motor)

Figure3.

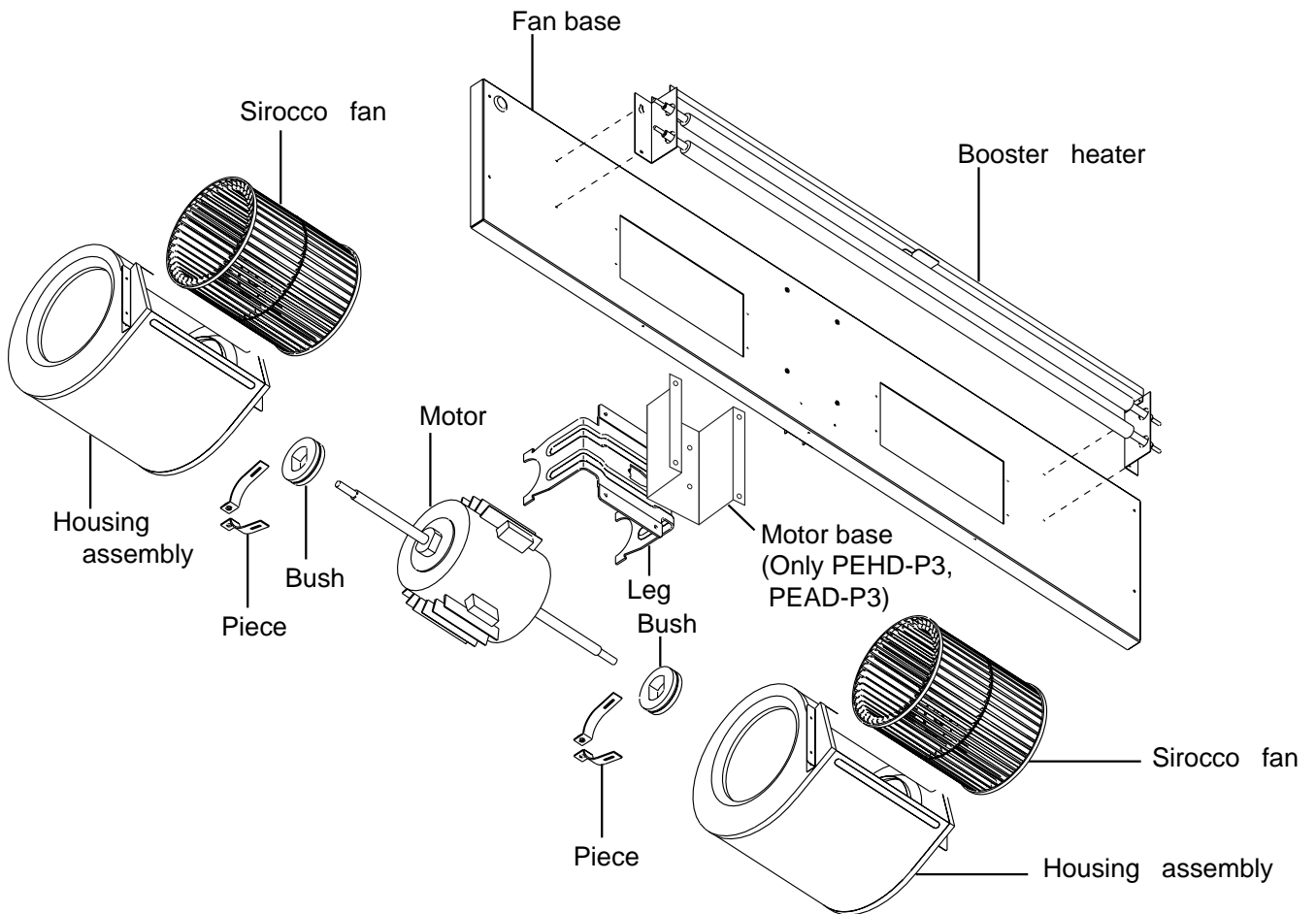

## II. Removing the booster heater

1. Remove the bottom plate, drain pan, and bottom plate assembly. (Refer I -1~3.)
2. Disconnect the booster heater connector from the controller box.
3. Remove the 2 lower screws on the both sides of the booster heater.
4. Loosen the 2 upper screws on the both sides of the booster heater.
5. Removing the booster heater.

Figure4.

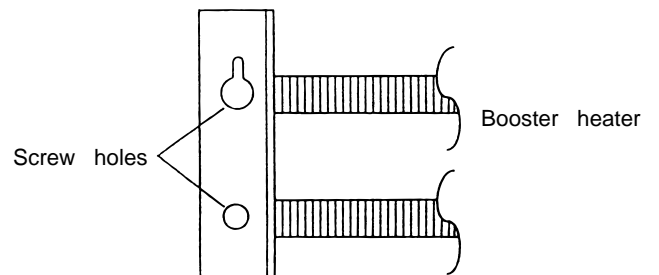

# 10

# PARTS LIST

PEHD-P1.6EAH, PEAD-P1.6EA, PEHD-P2EAH, PEAD-P2EA  
 PEHD-P2.5EAH, PEAD-P2.5EA, PEHD-P3EAH, PEAD-P3EA  
 PEHD-P4EAH, PEAD-P4EA, PEHD-P5EAH, PEAD-P5EA  
 PEHD-P6EAH, PEAD-P6EA

## EXTERNAL PARTS

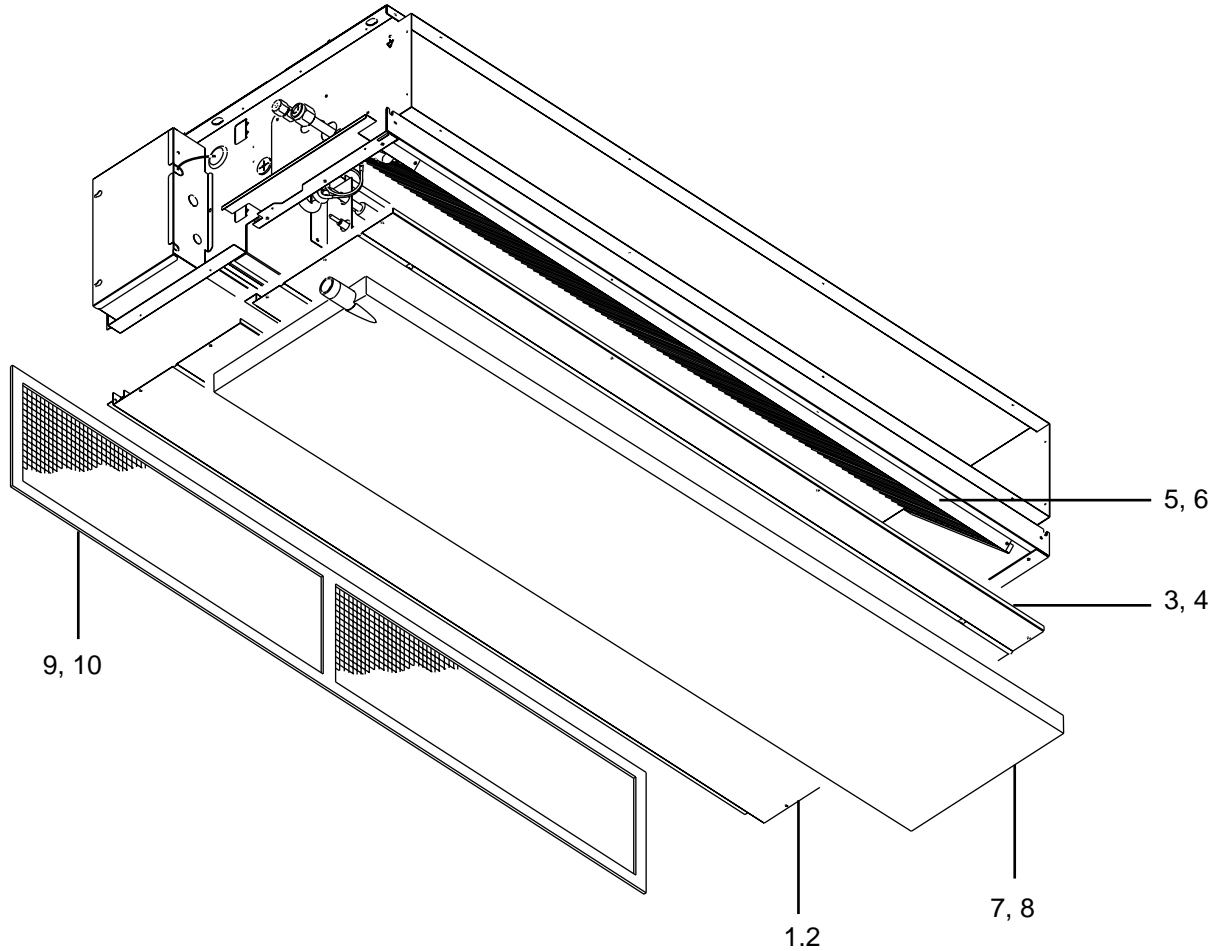

No.	Part No.	Part Name	Drawing No.	Qt'y/set						Spec.
				PEAD-P1.6EA	PEHD-P1.6EAH	PEAD-P2EA	PEHD-P2EAH	PEAD-P2.5EA	PEHD-P2.5EAH	
1	S70 031 669	Bottom plate 1	W638939Z03	1	1	1	1			
2	S70 011 669	Bottom plate 1	W638917Z03					1	1	
3	S70 081 669	Bottom plate 2 ass'y	W638940G02	1	1	1	1			
4	S70 091 669	Bottom plate 2 ass'y	W638918G02					1	1	
5	S70 030 480	H.EX.General ass'y	W268527G01	1	1	1	1			
6	S70 031 480	H.EX.General ass'y	W268527G02					1	1	
7	S70 011 529	Drain pan ass'y	W638942G01	1	1	1	1			
8	S70 021 529	Drain pan ass'y	W638920G01					1	1	
9	S70 021 500	Filter	W638181G01	1	1	1	1			
10	S70 031 501	Filter	W638181G02					1	1	

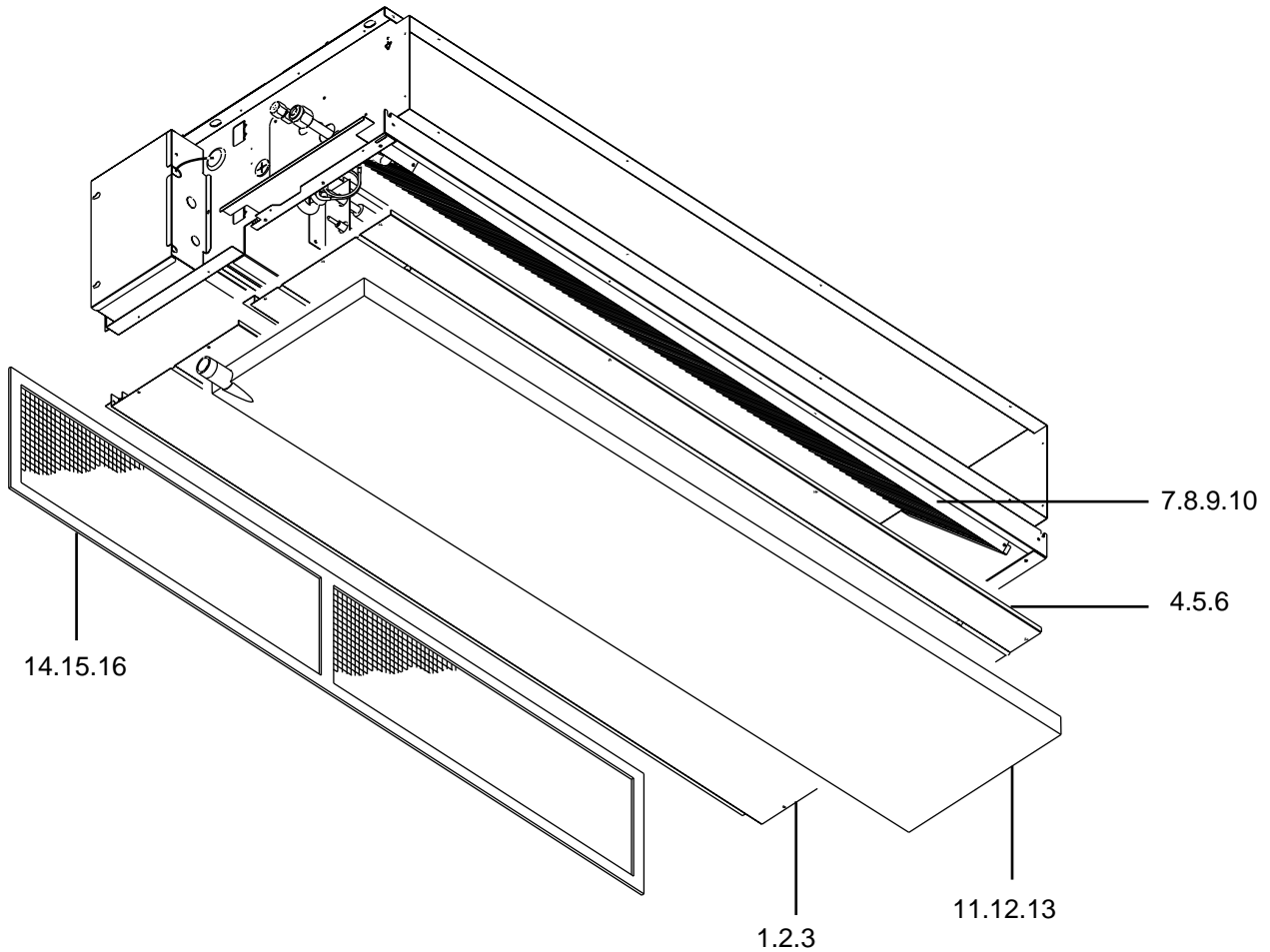

No.	Part No.	Part Name	Drawing No.	Qt'y/set								Spec.	
				PEAD-P3EA	PEHD-P3EHA	PEAD-P4EA	PEHD-P4EHA	PEAD-P5EA	PEHD-P5EHA	PEAD-P6EA	PEHD-P6EHA		
1	S70 041 669	Bottom plate 1	W634050Z01	1	1								
2	S70 042 669	Bottom plate 1	W634028Z01			1	1	1	1				
3	S70 040 669	Bottom plate 1	W631101Z04							1	1		
4	S70 051 669	Bottom plate 2 ass'y	W634052G01	1	1								
5	S70 052 669	Bottom plate 2 ass'y	W634030G01			1	1	1	1				
6	S70 050 669	Bottom plate 2 ass'y	W631188G02							1	1		
7	S70 032 480	H.EX.General ass'y	W268528G01	1	1								
8	S70 033 480	H.EX.General ass'y	W268528G02			1	1						
9	S70 034 480	H.EX.General ass'y	W268528G03					1	1				
10	S70 035 480	H.EX.General ass'y	W268529G01							1	1		
11	S70 050 529	Drain pan ass'y	W634056G01	1	1								
12	S70 060 529	Drain pan ass'y	W634034G01			1	1	1	1				
13	S70 040 529	Drain pan ass'y	W631186G01							1	1		
14	S70 050 500	Filter	W630129G06	1	1								
15	S70 040 500	Filter	W630129G05			1	1	1	1				
16	S70 010 500	Filter	W630129G02							1	1		

PEHD-P1.6EAH, PEAD-P1.6EA, PEHD-P2EAH, PEAD-P2EA  
 PEHD-P2.5EAH, PEAD-P2.5EA, PEHD-P3EAH, PEAD-P3EA  
 PEHD-P4EAH, PEAD-P4EA, PEHD-P5EAH, PEAD-P5EA  
 PEHD-P6EAH, PEAD-P6EA

**BLOWER PARTS**

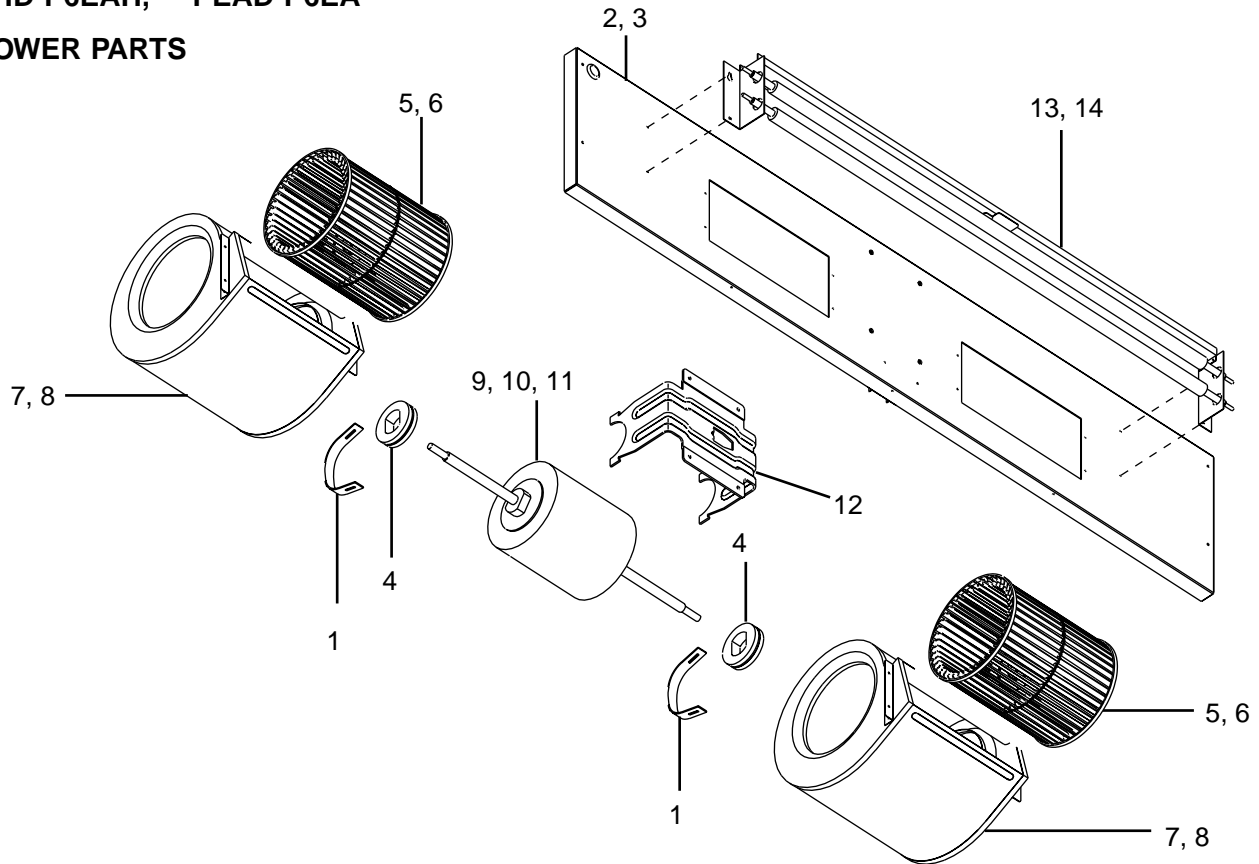

No.	Part No.	Part Name	Drawing No.	Qt'y/set								
				PEAD-P1.6EA	PEHD-P1.6EAH	PEAD-P2EA	PEHD-P2EAH	PEAD-P2.5EA	PEHD-P2.5EAH			
1	S70 652 131	Attachment	W353715H01	2	2	2	2	2	2			
2	S70 051 677	Fan base ass'y	W638932G02	1	1	1	1					
3	S70 061 677	Fan base ass'y	W638905G02					1	1			
4	S70 922 105	Bush	W818836H01	2	2	2	2	2	2			
5	S70 A88 114	Sirocco fan	W122296G01	2	2	2	2					
6	S70 A89 114	Sirocco fan	W122297G01					2	2			
7	S70 989 110	Housing ass'y	W638949G03	2	2	2	2					
8	S70 985 110	Housing ass'y	W638949G04					2	2			
9	S70 Y57 220	Motor	P714315X02	1	1							<MF>
10	S70 Y58 220	Motor	P714316X02			1	1					<MF>
11	S70 Y56 220	Motor	P714774X01					1	1			<MF>
12	S70 652 130	Motor support	W241060H03	1	1	1	1	1	1			
13	S70 Y07 300	Heater ass'y 3	P493639X02		1		1					
14	S70 Y03 300	Heater ass'y 4	P493640X02							1		

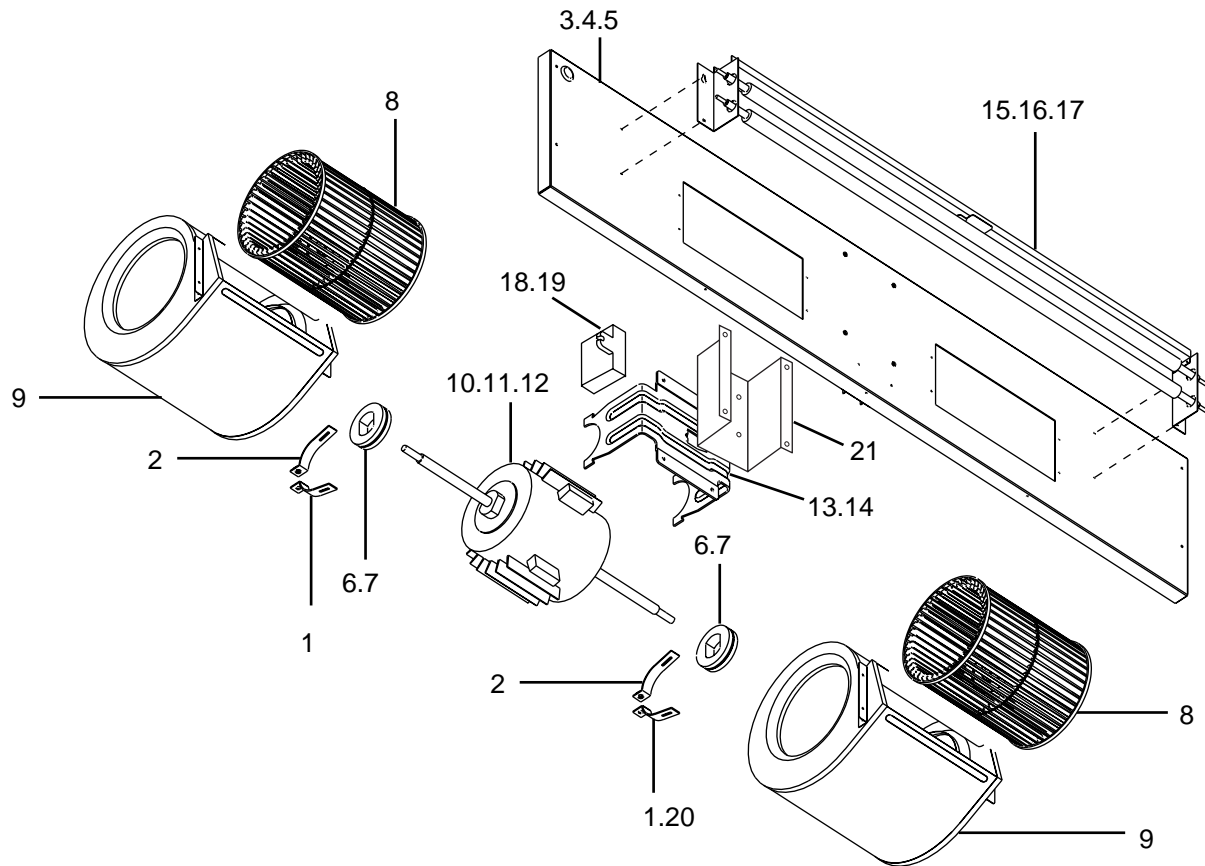

No.	Part No.	Part Name	Drawing No.	Qt'y/set								
				PEAD- P3EA	PEHD- P3EHA	PEAD- P4EA	PEHD- P4EHA	PEAD- P5EA	PEHD- P5EHA	PEAD- P6EA	PEHD- P6EHA	
1	S70 508 131	Piece	R02K338H02			2	2	2	2	2	2	
2	S70 508 132	Piece	R02K338G82			2	2	2	2	2	2	with a nut
3	S70 073 677	Fan base ass'y	W634058G02	1	1							
4	S70 072 677	Fan base ass'y	W634036G02			1	1	1	1			
5	S70 070 677	Fan base ass'y	W631187G02							1	1	
6	S70 766 105	Bush	W491760H02	2	2							
7	S70 Y01 105	Bush	W860050H02			2	2	2	2	2	2	
8	S70 Y07 114	Sirocco fan	W631126G02	2	2	2	2	2	2	2	2	20-25L
9	S70 001 110	Housing ass'y	W631120G01	2	2	2	2	2	2	2	2	
10	S70 Y15 220	Motor	P714661X01	1	1							<MF>150W,1Phase 220- 240V
11	S70 Y16 220	Motor	P714659X02			1	1					<MF>240W,1Phase 220- 240V
12	S70 Y17 220	Motor	P714614X02					1	1	1	1	<MF>250W,1Phase 220- 240V
13	S70 652 130	Motor support	W241060H03	1	1							
14	S70 Y08 130	Leg	W631122Z04			1	1	1	1	1	1	
15	S70 Y04 300	Heater ass'y 3	W258903G07		1							
16	S70 Y05 300	Heater ass'y 4	W258903G08				1					
17	S70 Y06 300	Heater ass'y 5	W258903G09						1		1	
18	S70 010 255	Capacitor 6	P412172X01			1	1					< C >
19	S70 020 255	Capacitor 16	P412223X01					2	2	2	2	< C >
* 20	S70 652 131	Attachment	W353715H01	2	2							
21	S70 090 130	Motor base	W634069Z01	1	1							

\*: Not illustrated

PEHD-P1.6EAH, PEAD-P1.6EA, PEHD-P2EAH, PEAD-P2EA  
 PEHD-P2.5EAH, PEAD-P2.5EA, PEHD-P3EAH, PEAD-P3EA  
 PEHD-P4EAH, PEAD-P4EA, PEHD-P5EAH, PEAD-P5EA  
 PEHD-P6EAH, PEAD-P6EA

**CONTROL BOX PARTS**

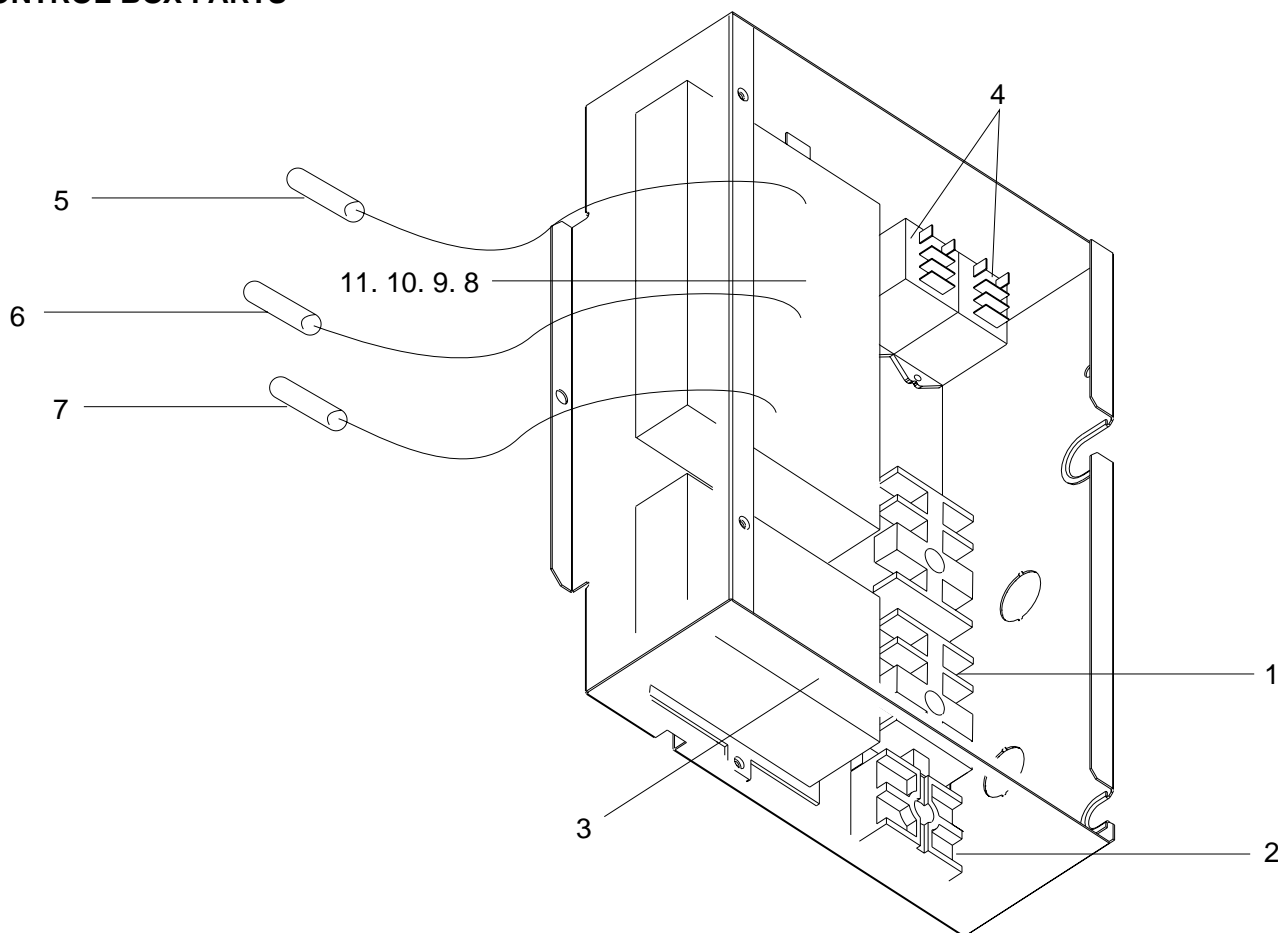

No.	Part No.	Part Name	Drawing No.	Qt'y/set						Spec.
				PEAD-P1.6EA	PEHD-P1.6EAH	PEAD-P2EA	PEHD-P2EAH	PEAD-P2.5EA	PEHD-P2.5EAH	
1	S70 979 717	Terminalbed	P436110X01	1	2	1	2	1	2	< TB4 >
2	S70 435 717	Terminalbed	BA73S950H02	1	1	1	1	1	1	< TB5 >
3	S70 E00 313	P.W.B DENGEN-E	P718898X01	1	1	1	1	1	1	
4	S70 274 215	Start relay	P421221X01		2		2		2	LY1F< 88H1,2 >
5	S70 070 202	Thermistor	P425455X01	1	1	1	1	1	1	< TH1 >
6	S70 080 202	Thermistor	P425459X02	1	1	1	1	1	1	< TH2 >
7	S70 090 202	Thermistor	P425458X02	1	1	1	1	1	1	< TH5 >
8	S70 011 310	P.W.B	P718899X02	1	1					
9	S70 012 310	P.W.B	P718900X02			1	1			
10	S70 013 310	P.W.B	P718901X02					1	1	

No.	Part No.	Part Name	Drawing No.	Qt'y/set								Spec.
				PEAD- P3EA	PEHD- P3EHA	PEAD- P4EA	PEHD- P4EHA	PEAD- P5EA	PEHD- P5EHA	PEAD- P6EA	PEHD- P6EHA	
1	S70 979 317	Terminalbed	P436110X01	1	2	1	2	1	2	1	2	< TB4 >
2	S70 435 717	Terminalbed	BA73S950H02	1	1	1	1	1	1	1	1	< TB5 >
3	S70 E00 313	P.W.B DENGEN-E	P718898X01	1	1	1	1	1	1	1	1	
4	S70 274 215	Start relay	P421221X01		2		2		2		2	LY1F< 88H1,2 >
5	S70 070 202	Thermistor	P425455X01	1	1	1	1	1	1	1	1	< TH1 >
6	S70 080 202	Thermistor	P425459X02	1	1	1	1	1	1	1	1	< TH2 >
7	S70 090 202	Thermistor	P425458X02	1	1	1	1	1	1	1	1	< TH5 >
8	S70 014 310	P.W.B	P718902X02	1	1							
9	S70 015 310	P.W.B	P718903X02			1	1					
10	S70 016 310	P.W.B	P718904X02					1	1			
11	S70 017 310	P.W.B	P718905X02							1	1	



PEHD-P1.6EAH, PEAD-P1.6EA, PEHD-P2EAH, PEAD-P2EA  
 PEHD-P2.5EAH, PEAD-P2.5EA, PEHD-P3EAH, PEAD-P3EA  
 PEHD-P4EAH, PEAD-P4EA, PEHD-P5EAH, PEAD-P5EA  
 PEHD-P6EAH, PEAD-P6EA

**ELECTRICAL PARTS**

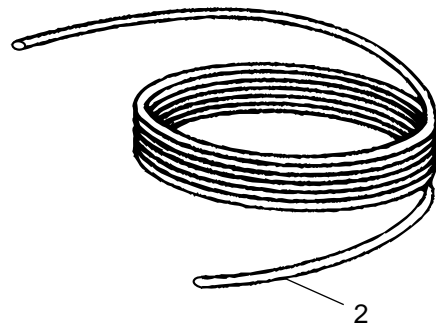
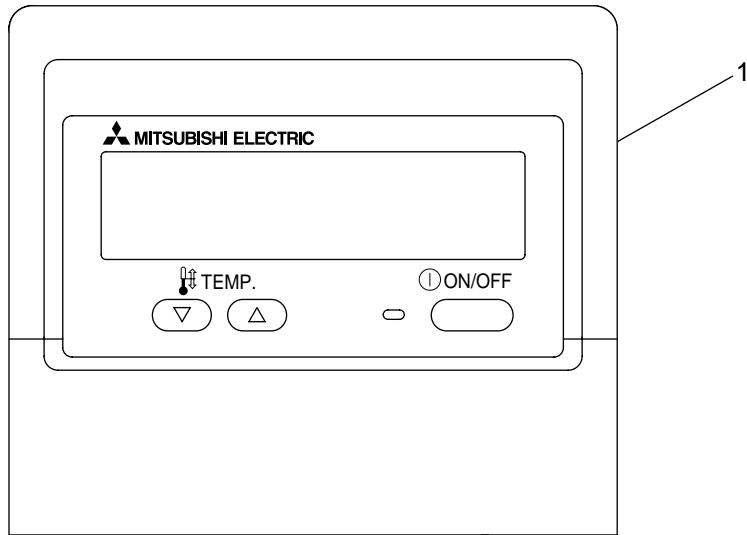

No.	Part No.	Part Name	Drawing No.	Qt'y/set								Spec.	
				PEAD-P3EA	PEHD-P3EHA	PEAD-P4EA	PEHD-P4EHA	PEAD-P5EA	PEHD-P5EHA	PEAD-P6EA	PEHD-P6EHA		
1	S70 030 713	Remote controller	W267102G13	1	1	1	1	1	1	1	1	1	MA Remo-con
2	S70 030 305	Remote controller cable	W873334G05	1	1	1	1	1	1	1	1	1	10 m

No.	Part No.	Part Name	Drawing No.	Qt'y/set								Spec.	
				PEAD-P1.6EA	PEHD-P1.6EAH	PEAD-P2EA	PEHD-P2EAH	PEAD-P2.5EA	PEHD-P2.5EAH				
1	S70 030 713	Remote controller	W267102G13	1	1	1	1	1	1				MA Remo-con
2	S70 030 305	Remote controller cable	W873334G05	1	1	1	1	1	1				10 m

# 11 OPTIONAL PARTS

## 1. REFRIGERANT PIPES

Service Ref. : PEHD-P1.6,2,2.5,3EAH/PEAD-P1.6,2,2.5,3EA

Part No.	PAC-05FFS-E	PAC-07FFS-E	PAC-10FFS-E	PAC-15FFS-E
Pipe length	5m	7m	10m	15m
Pipe size O.D.	Liquid : $\varnothing$ 9.52 Gas : $\varnothing$ 15.88			
Connection method	Indoor unit : Flared		Outdoor unit : Flared	

Service Ref. : PEHD-P4,5,6EAH/PEAD-P4,5,6EA

Part No.	PAC-SC51PI-E	PAC-SC52PI-E	PAC-SC53PI-E	PAC-SC54PI-E
Pipe length	5m	7m	10m	15m
Pipe size O.D.	Liquid : $\varnothing$ 9.52 Gas : $\varnothing$ 19.05			
Connection method	Indoor unit : Flared		Outdoor unit : Flared	

Note 1. How to connect refrigerant pipes.

Factory supplied optional refrigerant pipings contain refrigerant at the above atmospheric pressures. As long as connection takes no more than 5 minutes, no air will enter, and there will be no need for air purging.

Remove the blind caps and make the connections within 5 minutes. After the connections for the indoor and outdoor units are made, open the stop valve on the outdoor unit to allow refrigerant gas to flow.

If piping length exceeds 5m, an additional charge of refrigerant is needed.

Note 2. The following main parts are contained in the optional refrigerant piping kit.

Heat insulating cover, vinyl tapes, nipples, sleeve and flange (for wall hole).

## 2. CENTRALIZED REMOTE CONTROLLER

Allows individual or combined control of up to 16 units. When using this controller, a program timer adapter (PAC-825AD) is also needed.

Part No.	PAC-805RC
----------	-----------

## 3. PROGRAM TIMER ADAPTER

This adapter is needed when a centralized remote controller (PAC-805RC) is used.

Part No.	PAC-825AD
----------	-----------

## 4. TIMER ADAPTER

This adapter is needed for system control and for operation via external contacts.

Part No.	PAC-SA89TA-E
----------	--------------

## 5. MULTIPLE REMOTE CONTROLLER ADAPTER

This adapter is needed for remote indication (operation/check).

Part No.	PAC-SA88HA-E
----------	--------------

## 6. PROGRAM TIMER

Part No.	PAC-SC32PTA
----------	-------------

## 7. OPTIONAL MOTOR

The external static pressure of 130Pa allows long ducts to be used more extensively to enable the most convenient positioning of indoor units.

Part No.	PAC-SK005MT-F	PAC-SK004MT-F	PAC-SK003MT-F
Applied model	PEHD-P3EAH/PEAD-P3EA	PEHD-P4EAH/PEAD-P4EA	PEHD-P5,6EAH/PEAD-P5,6EA

## 8. DRAIN WATER LIFT-UP MECHANISM

This allows more versatility when selecting drain piping layouts.

Part No.	PAC-KE03DM-F
Applied model	PEHD-P3EAH/PEAD-P3EA, PEHD-P4EAH/PEAD-P4EA, PEHD-P5,6EAH/PEAD-P5,6EA

**Mr. SLIM™**

 **mitsubishi electric corporation**  
HEAD OFFICE MITSUBISHI DENKI BLDG. MARUNOUCHI TOKYO100 TELEX J24532 CABLE MELCO TOKYO