

TECHNICAL & SERVICE MANUAL

Series PCA Ceiling Suspended R407C

Indoor unit
[Model names]

PCA-P3HA

PCA-P5HA

[Service Ref.]

PCA-P3HA

PCA-P5HA

- Refer to the OCT03 REVISED EDITION-E as regarding control relation.
- This manual does not cover outdoor units. When serving them, please refer to the service manual No.OC261 REVISED EDITION-B and this manual in a set.

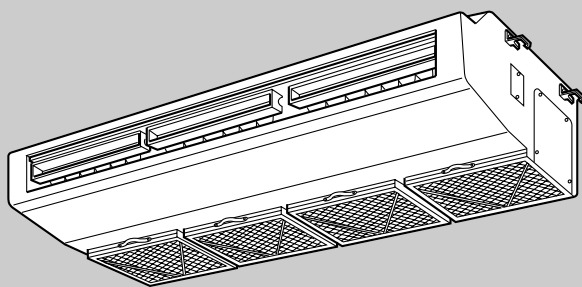

INDOOR UNIT

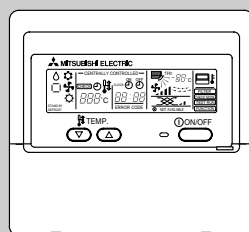

REMOTE CONTROLLER

CONTENTS

1. SAFETY PRECAUTION	2
2. PART NAMES AND FUNCTIONS.....	4
3. SPECIFICATIONS	6
4. DATA.....	10
5. OUTLINES AND DIMENSIONS	21
6. WIRING DIAGRAM.....	23
7. REFRIGERANT SYSTEM DIAGRAM	24
8. TROUBLESHOOTING	25
9. DISASSEMBLY PROCEDURE	26
10. PARTS LIST	30
11. OPTIONAL PARTS.....	33

Cautions for using with the outdoor unit which adopts R407C refrigerant.

- **Do not use the existing refrigerant piping.**
 - The old refrigerant and refrigerant oil in the existing piping contains a large amount of chlorine which may cause the refrigerant oil of the new unit to deteriorate.
- **Do not use copper pipes which are broken, deformed or discolour .**
 - In addition, be sure that the inner surfaces of the pipes are clean, free of hazardous sulphur and oxides, or have no dust / dirt, shaving particles, oils, moisture or any other contamination.
 - If there is a large amount of residual oil (hydraulic oil, etc.) inside the piping and joints, deterioration of the refrigerant oil will result.
- **Store the piping to be used during installation indoors and keep both ends of the piping sealed until just before brazing. (Store elbows and other joints in a plastic bag.)**
 - If dust, dirt, or water enters the refrigerant cycle, deterioration of the oil and compressor trouble may result.
- **Use ester oil, ether oil or alkyl benzene (small amount) as the refrigerant oil to coat flares and flange connections.**
 - The refrigerant oil will degrade if it is mixed with a large amount of mineral oil.
- **Use liquid refrigerant to fill the system.**
 - If gas refrigerant is used to fill the system, the composition of the refrigerant in the cylinder will change and performance may drop.
- **Do not use a refrigerant other than R407C.**
 - If another refrigerant (R22, etc.) is used, the chlorine in the refrigerant may cause the refrigerant oil to deteriorate.
- **Use a vacuum pump with a reverse flow check valve.**
 - The vacuum pump oil may flow back into the refrigerant cycle and cause the refrigerant oil to deteriorate.
- **Do not use the following tools that are used with conventional refrigerant. (Gauge manifold , charge hose, gas leak detector, reverse flow check valve, refrigerant charge base, vacuum gauge, refrigerant recovery equipment)**
 - If the conventional refrigerant and refrigerant oil are mixed in the R407C, the refrigerant may deteriorated.
 - If water is mixed in the R407C, the refrigerant oil may deteriorate.
 - Since R407C does not contain any chlorine, gas leak detectors for conventional refrigerant will not react to it.
- **Do not use a charging cylinder.**
 - Using a charging cylinder may cause the refrigerant to deteriorate.
- **Be especially careful when managing the tools.**
 - if dust, dirt, or water gets in the refrigerant cycle, the refrigerant may deteriorate.
- **Do not use the drier which is sold in the field.**
 - The drier for R407C refrigerant is per-attached to outdoor unit refrigerant circuit.
 - Some drier in the field are not in conformity with R407C refrigerant .

[1] Service tools

Use the below service tools as exclusive tools for R407C refrigerant.

No.	Tool name	Specifications
①	Gauge manifold	·Only for R407C.
		·Use the existing fitting SPECIFICATIONS. (UNF7/16)
		·Use high-tension side pressure of 3.43MPa or over.
②	Charge hose	·Only for R407C.
		·Use pressure performance of 5.10MPa or over.
③	Electronic scale	
④	Gas leak detector	·Use the detector for R407C.
⑤	Adapter for reverse flow check.	·Attach on vacuum pump.
⑥	Refrigerant charge base.	
⑦	Refrigerant cylinder.	·For R407C ·Top of cylinder (Brown)
		·Cylinder with syphon
⑧	Refrigerant recovery equipment.	

[2] Notice on repair service

- After recovering the all refrigerant in the unit, proceed to working.
- Do not release refrigerant in the air.
- After completing the repair service, recharge the cycle with the specified amount of liquid refrigerant.

[3] Refrigerant recharging

(1) Refrigerant recharging process

- ① Direct charging from the cylinder.
- R407C cylinder are available on the market has a syphon pipe.
 - Leave the syphon pipe cylinder standing and recharge it.
(By liquid refrigerant)

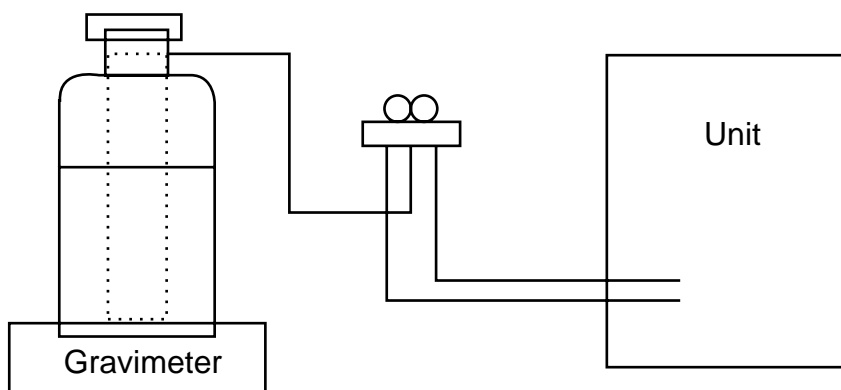

(2) Recharge in refrigerant leakage case

- After recovering the all refrigerant in the unit, proceed to working.
- Do not release the refrigerant in the air.
- After completing the repair service, recharge the cycle with the specified amount of liquid refrigerant.

2

PART NAMES AND FUNCTIONS

● Indoor (Main) Unit

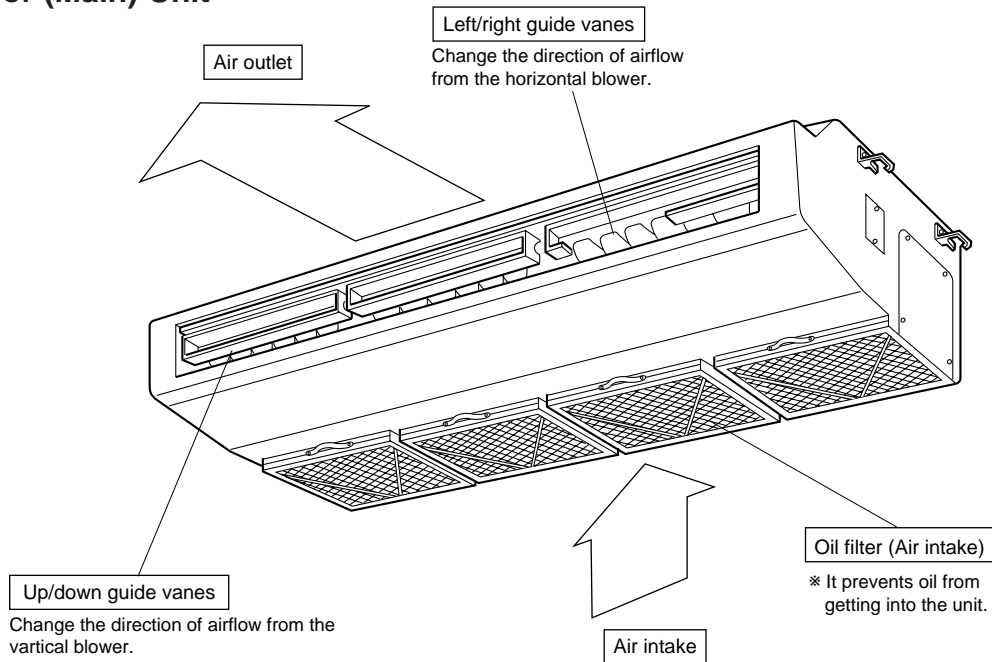

● Remote controller

Once the controls are set, the same operation mode can be repeated by simply pressing the ON/OFF button.

● Operation buttons

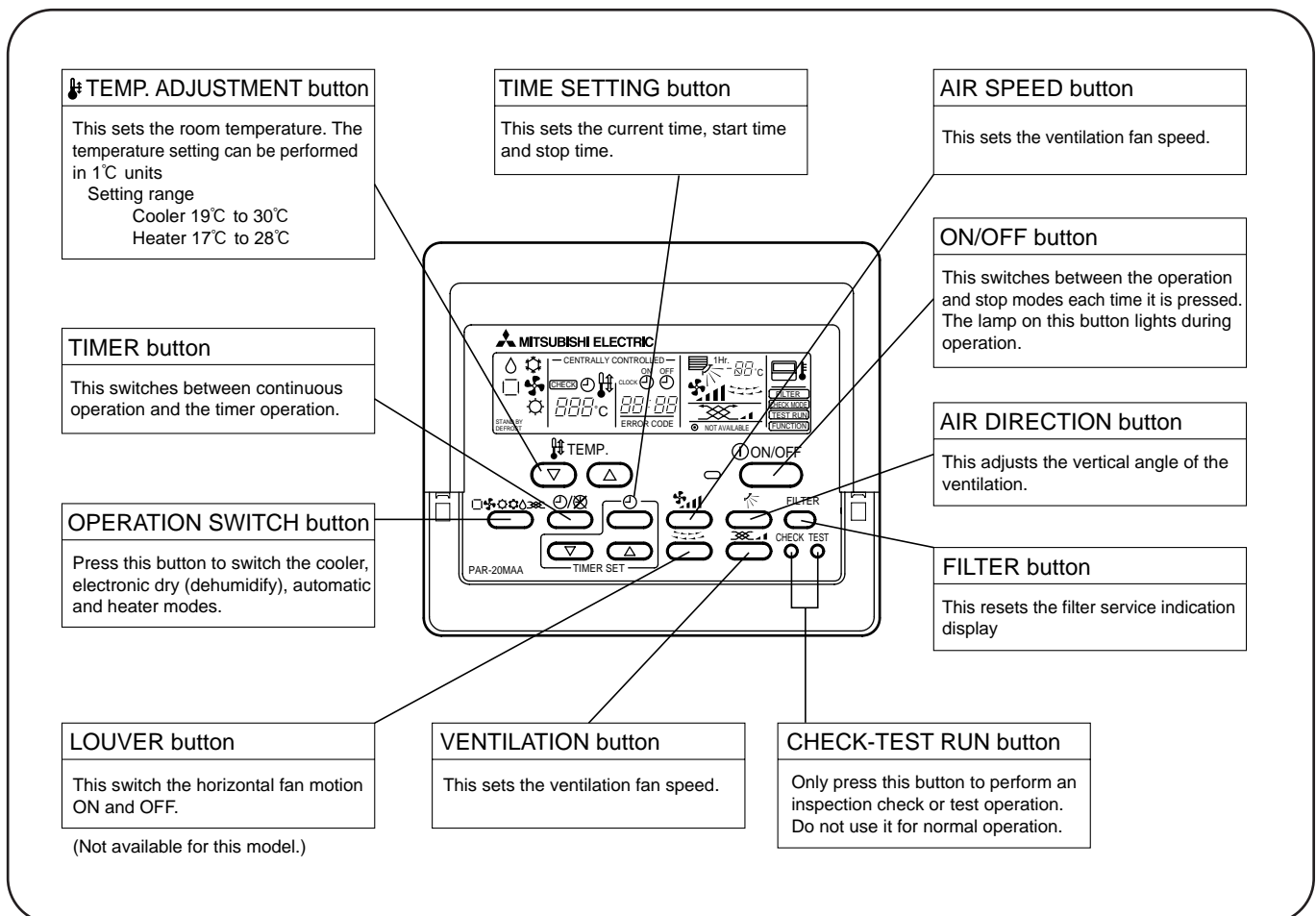

● Display

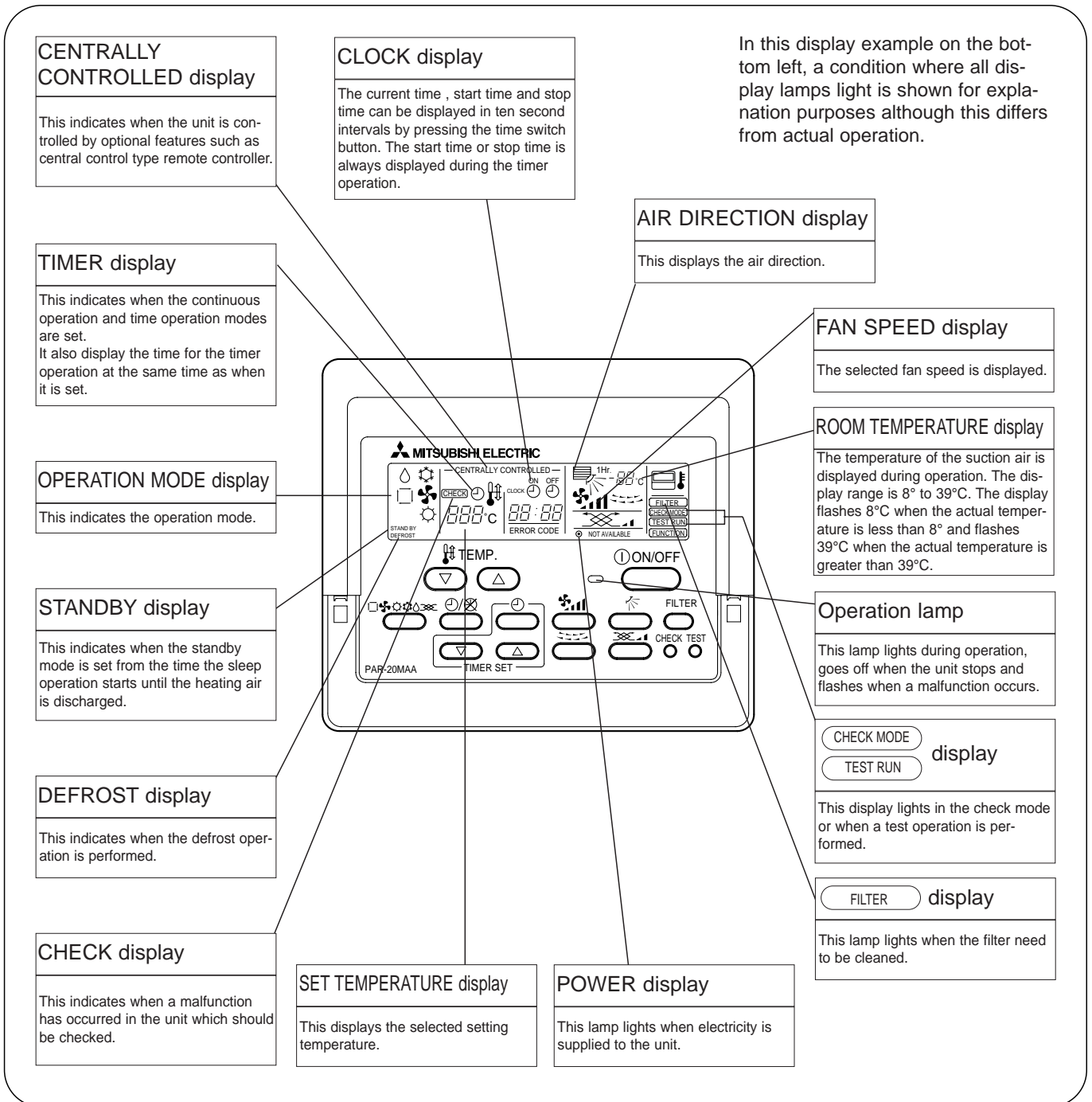

Caution

- Only the Power display lights when the unit is stopped and power supplied to the unit.
- When power is turned ON for the first time the (CENTRAL CTRL) display appears to go off momentarily but this is not a malfunction.
- When the central control remote control unit, which is sold separately, is used the ON-OFF button, operation switch button and TEMP. adjustment button do not operate.
- "NOT AVAILABLE" is displayed when the Air speed button are pressed. This indicates that this room unit is not equipped with the fan direction adjustment function and the louver function.
- When power is turned ON for the first time, it is normal that "H0" is displayed on the room temperature indication (For max. 2minutes). Please wait until this "H0" indication disappear then start the operation.

3

SPECIFICATIONS

1. Heat pump type Rating Conditions (ISO T1)

Item		Service Ref.	PCA-P3HA	
Function			Cooling	Heating
Capacity		Btu/h	25,600	31,400
		W	7,500	9,200
Total input		kW	3.36	3.41
Service Ref.			PCA-P3HA	
Power supply			Single phase, 50Hz, 220-230-240V	
	Input	kW	0.09	0.09
	Running current	A	0.43	0.43
	Starting current	A	0.86	0.86
External finish			Stainless steel	
Heat exchanger			Plate fin coil	
INDOOR UNIT	Fan	Fan(drive) x No.	Sirocco (direct) x 2	
		Fan motor output	0.04	
		Airflow(Lo-Hi)	17-19 <600-670>	
		External static pressure	0 (direct blow)	
Operation control & Thermostat			Remote controller & built-in	
Noise level(Lo-Hi)			34-38	
Unit drain pipe I.D.			26(1)	
Dimensions	W	mm(in.)	1,136(44-3/4)	
	D	mm(in.)	650(25-5/8)	
	H	mm(in.)	280(11)	
Weight		kg(lbs)	41(90)	
Service Ref.			PUH-P3VGAA1.UK / PUH-P3YGAA1.UK	
Power supply			Single phase, 50Hz, 220-230-240V / 3 phase, 50Hz, 380-400-415V (4wires)	
	Running current	A	14.83 / 4.96	14.85 / 5.04
	Starting current	A	93 / 47	
External finish			Munsell 5Y 7/1	
Refrigerant control			Linear Expansion Valve	
Compressor			Hermetic	
	Model		NE52VNJMT / NE52YDKMT	
	Motor output	kW	2.5	
	Starter type		Line start	
	Protection devices		Inner thermostat, HP switch, Discharge thermo. / Anti-phase protector, Thermal relay, HP switch, Discharge thermo.	
Crankcase heater		W	38	
Heat exchanger			Plate fin coil	
OUTDOOR UNIT	Fan	Fan(drive) x No.	Propeller (direct) x 1	
		Fan motor output	0.070	
		Airflow	50(1,770)	
Defrost method			Reverse cycle	
Noise level	Cooling	dB	49	
	Heating	dB	51	
Dimensions	W	mm(in.)	900(35-7/16)	
	D	mm(in.)	330+20(13+3/4)	
	H	mm(in.)	855(33-5/8)	
Weight		kg(lbs)	79(174)	
Refrigerant			R407C	
	Charge	kg(lbs)	3.3(7.3)	
	Oil (Model)	L	1.3 (Ester) MEL56	
Pipe size O.D.	Liquid	mm(in.)	9.52(3/8)	
	Gas	mm(in.)	15.88(5/8)	
Connection method	Indoor side		Flared	
	Outdoor side		Flared	
Between the indoor & outdoor unit	Height difference		Max. 50m	
	Piping length		Max. 50m	
REFRIGERANT PIPING				

Notes1. Rating Conditions (ISO T1)

Cooling : Indoor : D.B. 27°C(80°F), W.B. 19°C (66°F) Outdoor : D.B. 35°C(95°F), W.B. 24°C (75°F)

Heating : Indoor : D.B. 20°C(68°F) Outdoor : D.B. 7°C(45°F), W.B. 6°C (43°F)

Refrigerant piping length (one way) : 5m (16ft)

2. Guaranteed operating range

		Indoor	Outdoor
Cooling	Upper limit	D.B. 35°C, W.B. 22.5°C	D.B. 46°C
	Lower limit	D.B. 19°C, W.B. 15°C	D.B. -5°C
Heating	Upper limit	D.B. 28°C	D.B. 24°C, W.B. 18°C
	Lower limit	D.B. 17°C	D.B. -11°C, W.B. -12°C

3. Above data based on indicated voltage

Indoor Unit Single phase 230V 50Hz

Outdoor Unit Single phase 230V 50Hz / 3 phase 400V 50Hz

Rating Conditions (ISO T1)

Item			Service Ref.	PCA-P5HA		
Function				Cooling	Heating	
Capacity		Btu/h		44,400	54,600	
		W		13,000	16,000	
Total input		kW		4.90	4.98	
Service Ref.				PCA-P5HA		
Power supply				Single phase, 50Hz, 220-230-240V		
Input		kW		0.26	0.26	
Running current		A		1.19	1.19	
Starting current		A		2.38	2.38	
External finish				Stainless steel		
Heat exchanger				Plate fin coil		
INDOOR UNIT	Fan	Fan(drive) x No.		Sirocco (direct) x 4		
		Fan motor output		0.08+0.08		
	Airflow(Lo-Hi)		m ³ /min(CFM)		30-38 <1,060-1,350>	
	External static pressure		Pa(mmAq)		0 (direct blow)	
	Operation control & Thermostat				Remote controller & built-in	
Noise level(Lo-Hi)		dB		44-50		
Unit drain pipe I.D.			mm(in.)		26(1)	
Dimensions	W	mm(in.)		1,520(59-7/8)		
	D	mm(in.)		650(25-5/8)		
	H	mm(in.)		280(11)		
Weight		kg(lbs)		56(124)		
Service Ref.				PUH-P5YGAA1.UK		
Power supply				3 phase, 50Hz, 380-400-415V (4wires)		
Running current		A		6.85	7.07	
Starting current		A		65.5		
External finish				Munsell 5Y 7/1		
Refrigerant control				Linear Expansion Valve		
Compressor				Hermetic		
Model				ZR61KCW-TFD		
Motor output		kW		3.5		
Starter type				Line start		
Protection devices				Anti-phase protector, Internal thermostat, HP switch, Thermal relay, Discharge thermo		
Crankcase heater		W		38		
Heat exchanger				Plate fin coil		
OUTDOOR UNIT	Fan	Fan(drive) x No.		Propeller (direct) x 2		
		Fan motor output		0.070+0.070		
	Airflow		m ³ /min(CFM)		95(3,360)	
Defrost method				Reverse cycle		
Noise level	Cooling	dB		55		
	Heating	dB		56		
Dimensions	W	mm(in.)		1,050(41-5/16)		
	D	mm(in.)		330+20(13+3/4)		
	H	mm(in.)		1,260(49-5/8)		
Weight		kg(lbs)		112(247)		
Refrigerant				R407C		
Charge		kg(lbs)		4.6(10.1)		
Oil (Model)				1.690 (Ester) 3MAW-POE		
Pipe size O.D.	Liquid	mm(in.)		9.52(3/8)		
	Gas	mm(in.)		19.05(3/4)		
Connection method		Indoor side		Flared		
		Outdoor side		Flared		
Between the indoor & outdoor unit		Height difference		Max. 50m		
		Piping length		Max. 50m		

Notes1. Rating Conditions (ISO T1)

Cooling : Indoor : D.B. 27°C(80°F), W.B. 19°C (66°F) Outdoor : D.B. 35°C(95°F), W.B. 24°C (75°F)

Heating : Indoor : D.B. 20°C(68°F) Outdoor : D.B. 7°C(45°F), W.B. 6°C (43°F)

Refrigerant piping length (one way) : 5m (16ft)

2. Guaranteed operating range

		Indoor	Outdoor
Cooling	Upper limit	D.B. 35°C, W.B. 22.5°C	D.B. 46°C
	Lower limit	D.B. 19°C, W.B. 15°C	D.B. -5°C
Heating	Upper limit	D.B. 28°C	D.B. 24°C, W.B. 18°C
	Lower limit	D.B. 17°C	D.B. -11°C, W.B. -12°C

3. Above data based on indicated voltage

Indoor Unit Single phase 230V 50Hz

Outdoor Unit 3 phase 400V 50Hz

Rating Conditions (ISO T1)

Item		Service Ref.	PCA-P3HA		
Function			Cooling		
Capacity		Btu/h	25,600		
		W	7,500		
Total input		kW	3.36		
INDOOR UNIT	Service Ref.		PCA-P3HA		
	Power supply		Single phase, 50Hz, 220-230-240V		
	Input		kW	0.09	
	Running current		A	0.41	
	Starting current		A	0.86	
	External finish			Stainless steel	
	Heat exchanger			Plate fin coil	
	Fan	Fan(drive) x No.		Sirocco (direct) X 2	
		Fan motor output		kW	0.04
		Airflow(Lo-Hi)		m ³ /min <CFM>	17-19 <600-670>
		External static pressure		Pa(mmAq)	0 (direct blow)
	Operation control & Thermostat			Remote controller & built-in	
	Noise level(Lo-Hi)		dB	34-38	
	Unit drain pipe I.D.		mm(in.)	26(1)	
	Dimensions	W	mm(in.)	1,136(44-3/4)	
D		mm(in.)	650(25-5/8)		
H		mm(in.)	280(11)		
Weight		kg(lbs)	41(90)		
OUTDOOR UNIT	Service Ref.		PU-P3VGAA1.UK / PU-P3YGAA1.UK		
	Power supply		Single-phase, 50Hz, 220-230-240V / 3-phase, 50Hz, 380-400-415V (4wires)		
	Running current		A	14.02 / 4.78	
	Starting current		A	93 / 47	
	External finish			Munsell 5Y 7/1	
	Refrigerant control			Linear Expansion Valve	
	Compressor			Hermetic	
	Model			NE52VNJMT / NE52YDKMT	
	Motor output		KW	2.5	
	Starter type			Line start	
	Protection devices			Inner thermostat, HP switch, Discharge thermo / Anti-phase protector, Thermal relay, HP switch, Discharge thermo	
	Crankcase heater		W	38	
	Heat exchanger			Plate fin coil	
	Fan	Fan(drive) x No.		Propeller (direct) X 1	
		Fan motor output		kW	0.070
		Airflow		m ³ /min <CFM>	50(1,770)
	Defrost method			—	
	Noise level		Cooling	dB	49
Dimensions	W	mm(in.)	900(35-7/16)		
	D	mm(in.)	330+20(13+3/4)		
	H	mm(in.)	855(33-5/8)		
Weight		kg(lbs)	79(174)		
REFRIGERANT PIPING	Refrigerant		R407C		
	Charge		kg(lbs)	3.3(7.3)	
	Compressor oil (Model)		L	1.3 (Ester) MEL56	
	Pipe size O.D.	Liquid	mm(in.)	9.52(3/8)	
		Gas	mm(in.)	15.88(5/8)	
	Connection method	Indoor side		Flared	
		Outdoor side		Flared	
	Between the indoor & outdoor unit		Height difference	Max. 50m	
		Piping length	Max. 50m		

Notes1. Rating Conditions (ISO T1)

Cooling : Indoor : D.B. 27°C (80°F), W.B. 19°C (66°F)
 Outdoor : D.B. 35°C (95°F), W.B. 24°C (75°F)
 Refrigerant piping length (one way) : 5m(16ft)

2. Guaranteed operating range		Indoor	Outdoor
Cooling	Upper limit	D.B. 35°C, D.B. 22.5°C	D.B. 46°C
	Lower limit	D.B. 19°C, D.B. 15°C	D.B. -5°C

3. Above data based on indicated voltage

Indoor Unit Single phase 230V 50Hz
 Outdoor Unit Single phase 230V 50Hz / 3 phase 400V 50Hz

Rating Conditions (ISO T1)

Item		Service Ref.	PCA-P5HA	
Function			Cooling	
Capacity		Btu/h	44,400	
		W	13,000	
Total input		kW	4.90	
Service Ref.			PCA-P5HA	
Power supply			Single phase, 50Hz, 220-230-240V	
Fan		Input	kW	0.26
		Running current	A	1.19
		Starting current	A	2.38
External finish			Stainless steel	
Heat exchanger			Plate fin coil	
Fan		Fan(drive) x No.	Sirocco (direct) X 4	
		Fan motor output	kW	0.08+0.08
		Airflow(Lo-Hi)	m ³ /min <CFM>	30-38 <1,060-1,350>
		External static pressure	Pa(mmAq)	0 (direct blow)
Operation control & Thermostat			Remote controller & built-in	
Noise level(Lo-Hi)		dB	44-50	
Unit drain pipe I.D.		mm(in.)	26(1)	
Dimensions		W	mm(in.)	1,520(59-7/8)
		D	mm(in.)	650(25-5/8)
		H	mm(in.)	280(11)
Weight		kg(lbs)	56(124)	
Service Ref.			PU-P5YGAA1.UK	
Power supply			3-phase, 50Hz, 380-400-415V (4wires)	
Fan		Running current	A	6.85
		Starting current	A	65.5
External finish			Munsell 5Y 7/1	
Refrigerant control			Linear Expansion Valve	
Compressor			Hermetic	
		Model	ZR61KCW-TFD	
		Motor output	KW	3.5
		Starter type		Line start
		Protection devices		Anti-phase protector, Internal thermostat, HP switch, Thermal relay, Discharge thermo
Crankcase heater		W	38	
Heat exchanger			Plate fin coil	
Fan		Fan(drive) x No.	Propeller (direct) X 2	
		Fan motor output	kW	0.070+0.070
		Airflow	m ³ /min <CFM>	95(3,360)
Defrost method			—	
Noise level		dB	55	
Dimensions		Cooling	mm(in.)	1,050(41-5/16)
		W	mm(in.)	330+20(13+3/4)
		D	mm(in.)	1,260(49-5/8)
Weight		H	kg(lbs)	112(247)
Refrigerant			R407C	
		Charge	kg(lbs)	4.6(10.1)
		Compressor oil (Model)	L	1.690 (Ester) 3MAW-POE
Pipe size O.D.		Liquid	mm(in.)	9.52(3/8)
		Gas	mm(in.)	19.05(3/4)
Connection method		Indoor side		Flared
		Outdoor side		Flared
Between the indoor & outdoor unit		Height difference		Max. 50m
		Piping length		Max. 50m

Notes 1. Rating Conditions (ISO T1)

Cooling : Indoor : D.B. 27°C (80°F), W.B. 19°C (66°F)
 Outdoor : D.B. 35°C (95°F), W.B. 24°C (75°F)
 Refrigerant piping length (one way) : 5m(16ft)

2. Guaranteed operating range

		Indoor	Outdoor
Cooling	Upper limit	D.B. 35°C, D.B. 22.5°C	D.B. 46°C
	Lower limit	D.B. 19°C, D.B. 15°C	D.B. -5°C

3. Above data based on indicated voltage

Indoor Unit Single phase 230V 50Hz
 Outdoor Unit 3 phase 400V 50Hz

1. PERFORMANCE DATA (240V)

1) COOLING CAPACITY<1>

PCA-P3HA

Indoor Intake air D.B.(°C)	Indoor Intake air W.B.(°C)	Outdoor intake air D.B.(°C)											
		20				25				30			
		CA	SHC(W)	SHF	P.C.	CA	SHC(W)	SHF	P.C.	CA	SHC(W)	SHF	P.C.
20	16	7,425	4,604	0.62	2.69	7,200	4,464	0.62	2.84	6,975	4,325	0.62	3.01
20	18	7,950	3,975	0.50	2.74	7,725	3,863	0.50	2.89	7,463	3,731	0.50	3.09
20	20	8,550	3,249	0.38	2.82	8,363	3,178	0.38	2.96	8,138	3,092	0.38	3.16
22	16	7,425	5,198	0.70	2.69	7,200	5,040	0.70	2.84	6,975	4,883	0.70	3.01
22	18	7,950	4,611	0.58	2.74	7,725	4,481	0.58	2.89	7,463	4,328	0.58	3.09
22	20	8,550	3,933	0.46	2.82	8,363	3,847	0.46	2.96	8,138	3,743	0.46	3.16
24	16	7,425	5,792	0.78	2.69	7,200	5,616	0.78	2.84	6,975	5,441	0.78	3.01
24	18	7,950	5,247	0.66	2.74	7,725	5,099	0.66	2.89	7,463	4,925	0.66	3.09
24	20	8,550	4,617	0.54	2.82	8,363	4,516	0.54	2.96	8,138	4,394	0.54	3.16
26	16	7,425	6,386	0.86	2.69	7,200	6,192	0.86	2.84	6,975	5,999	0.86	3.01
26	18	7,950	5,883	0.74	2.74	7,725	5,717	0.74	2.89	7,463	5,522	0.74	3.09
26	20	8,550	5,301	0.62	2.82	8,363	5,185	0.62	2.96	8,138	5,045	0.62	3.16
28	16	7,425	6,980	0.94	2.69	7,200	6,768	0.94	2.84	6,975	6,557	0.94	3.01
28	18	7,950	6,519	0.82	2.74	7,725	6,335	0.82	2.89	7,463	6,119	0.82	3.09
28	20	8,550	5,985	0.70	2.82	8,363	5,854	0.70	2.96	8,138	5,696	0.70	3.16
30	16	7,425	7,425	1.00	2.69	7,200	7,200	1.00	2.84	6,975	6,975	1.00	3.01
30	18	7,950	7,155	0.90	2.74	7,725	6,953	0.90	2.89	7,463	6,716	0.90	3.09
30	20	8,550	6,669	0.78	2.82	8,363	6,523	0.78	2.96	8,138	6,347	0.78	3.16
32	16	7,425	7,425	1.00	2.69	7,200	7,200	1.00	2.84	6,975	6,975	1.00	3.01
32	18	7,950	7,791	0.98	2.74	7,725	7,571	0.98	2.89	7,463	7,313	0.98	3.09
32	20	8,550	7,353	0.86	2.82	8,363	7,192	0.86	2.96	8,138	6,998	0.86	3.16
34	16	7,425	7,425	1.00	2.69	7,200	7,200	1.00	2.84	6,975	6,975	1.00	3.01
34	18	7,950	7,950	1.00	2.74	7,725	7,725	1.00	2.89	7,463	7,463	1.00	3.09
34	20	8,550	8,037	0.94	2.82	8,363	7,861	0.94	2.96	8,138	7,649	0.94	3.16

Notes CA : Capacity (W)

P.C. : Power consumption (kW)

SHC(W) : Sensible heat capacity

SHF : Sensible heat factor

**COOLING CAPACITY<2>
PCA-P3HA**

Indoor Intake air D.B.(°C)	Indoor Intake air W.B.(°C)	Outdoor intake air D.B.(°C)											
		35				40				45			
		CA	SHC(W)	SHF	P.C.	CA	SHC(W)	SHF	P.C.	CA	SHC(W)	SHF	P.C.
20	16	6,675	4,139	0.62	3.23	6,375	3,953	0.62	3.46	6,075	3,767	0.62	3.75
20	18	7,200	3,600	0.50	3.31	6,975	3,488	0.50	3.56	6,525	3,263	0.50	3.83
20	20	7,800	2,964	0.38	3.39	7,500	2,850	0.38	3.63	7,050	2,679	0.38	3.90
22	16	6,675	4,673	0.70	3.23	6,375	4,463	0.70	3.46	6,075	4,253	0.70	3.75
22	18	7,200	4,176	0.58	3.31	6,975	4,046	0.58	3.56	6,525	3,785	0.58	3.83
22	20	7,800	3,588	0.46	3.39	7,500	3,450	0.46	3.63	7,050	3,243	0.46	3.90
24	16	6,675	5,207	0.78	3.23	6,375	4,973	0.78	3.46	6,075	4,739	0.78	3.75
24	18	7,200	4,752	0.66	3.31	6,975	4,604	0.66	3.56	6,525	4,307	0.66	3.83
24	20	7,800	4,212	0.54	3.39	7,500	4,050	0.54	3.63	7,050	3,807	0.54	3.90
26	16	6,675	5,741	0.86	3.23	6,375	5,483	0.86	3.46	6,075	5,225	0.86	3.75
26	18	7,200	5,328	0.74	3.31	6,975	5,162	0.74	3.56	6,525	4,829	0.74	3.83
26	20	7,800	4,836	0.62	3.39	7,500	4,650	0.62	3.63	7,050	4,371	0.62	3.90
28	16	6,675	6,275	0.94	3.23	6,375	5,993	0.94	3.46	6,075	5,711	0.94	3.75
28	18	7,200	5,904	0.82	3.31	6,975	5,720	0.82	3.56	6,525	5,351	0.82	3.83
28	20	7,800	5,460	0.70	3.39	7,500	5,250	0.70	3.63	7,050	4,935	0.70	3.90
30	16	6,675	6,675	1.00	3.23	6,375	6,375	1.00	3.46	6,075	6,075	1.00	3.75
30	18	7,200	6,480	0.90	3.31	6,975	6,278	0.90	3.56	6,525	5,873	0.90	3.83
30	20	7,800	6,084	0.78	3.39	7,500	5,850	0.78	3.63	7,050	5,499	0.78	3.90
32	16	6,675	6,675	1.00	3.23	6,375	6,375	1.00	3.46	6,075	6,075	1.00	3.75
32	18	7,200	7,056	0.98	3.31	6,975	6,836	0.98	3.56	6,525	6,395	0.98	3.83
32	20	7,800	6,708	0.86	3.39	7,500	6,450	0.86	3.63	7,050	6,063	0.86	3.90
34	16	6,675	6,675	1.00	3.23	6,375	6,375	1.00	3.46	6,075	6,075	1.00	3.75
34	18	7,200	7,200	1.00	3.31	6,975	6,975	1.00	3.56	6,525	6,525	1.00	3.83
34	20	7,800	7,332	0.94	3.39	7,500	7,050	0.94	3.63	7,050	6,627	0.94	3.90

Notes CA : Capacity (W)
P.C. : Power consumption (kW)

SHC(W) : Sensible heat capacity
SHF : Sensible heat factor

**COOLING CAPACITY<3>
PCA-P5HA**

Indoor Intake air D.B.(°C)	Indoor Intake air W.B.(°C)	Outdoor intake air D.B.(°C)											
		20				25				30			
		CA	SHC(W)	SHF	P.C.	CA	SHC(W)	SHF	P.C.	CA	SHC(W)	SHF	P.C.
20	16	12,870	8,366	0.65	3.92	12,480	8,112	0.65	4.14	12,090	7,859	0.65	4.39
20	18	13,780	7,303	0.53	3.99	13,390	7,097	0.53	4.21	12,935	6,856	0.53	4.51
20	20	14,820	6,076	0.41	4.12	14,495	5,943	0.41	4.31	14,105	5,783	0.41	4.61
22	16	12,870	9,395	0.73	3.92	12,480	9,110	0.73	4.14	12,090	8,826	0.73	4.39
22	18	13,780	8,406	0.61	3.99	13,390	8,168	0.61	4.21	12,935	7,890	0.61	4.51
22	20	14,820	7,262	0.49	4.12	14,495	7,103	0.49	4.31	14,105	6,911	0.49	4.61
24	16	12,870	10,425	0.81	3.92	12,480	10,109	0.81	4.14	12,090	9,793	0.81	4.39
24	18	13,780	9,508	0.69	3.99	13,390	9,239	0.69	4.21	12,935	8,925	0.69	4.51
24	20	14,820	8,447	0.57	4.12	14,495	8,262	0.57	4.31	14,105	8,040	0.57	4.61
26	16	12,870	11,454	0.89	3.92	12,480	11,107	0.89	4.14	12,090	10,760	0.89	4.39
26	18	13,780	10,611	0.77	3.99	13,390	10,310	0.77	4.21	12,935	9,960	0.77	4.51
26	20	14,820	9,633	0.65	4.12	14,495	9,422	0.65	4.31	14,105	9,168	0.65	4.61
28	16	12,870	12,484	0.97	3.92	12,480	12,106	0.97	4.14	12,090	11,727	0.97	4.39
28	18	13,780	11,713	0.85	3.99	13,390	11,382	0.85	4.21	12,935	10,995	0.85	4.51
28	20	14,820	10,819	0.73	4.12	14,495	10,581	0.73	4.31	14,105	10,297	0.73	4.61
30	16	12,870	12,870	1.00	3.92	12,480	12,480	1.00	4.14	12,090	12,090	1.00	4.39
30	18	13,780	12,815	0.93	3.99	13,390	12,453	0.93	4.21	12,935	12,030	0.93	4.51
30	20	14,820	12,004	0.81	4.12	14,495	11,741	0.81	4.31	14,105	11,425	0.81	4.61
32	16	12,870	12,870	1.00	3.92	12,480	12,480	1.00	4.14	12,090	12,090	1.00	4.39
32	18	13,780	13,780	1.00	3.99	13,390	13,390	1.00	4.21	12,935	12,935	1.00	4.51
32	20	14,820	13,190	0.89	4.12	14,495	12,901	0.89	4.31	14,105	12,553	0.89	4.61
34	16	12,870	12,870	1.00	3.92	12,480	12,480	1.00	4.14	12,090	12,090	1.00	4.39
34	18	13,780	13,780	1.00	3.99	13,390	13,390	1.00	4.21	12,935	12,935	1.00	4.51
34	20	14,820	14,375	0.97	4.12	14,495	14,060	0.97	4.31	14,105	13,682	0.97	4.61

Notes CA : Capacity (W)
P.C. : Power consumption (kW)

SHC(W) : Sensible heat capacity
SHF : Sensible heat factor

**COOLING CAPACITY<4>
PCA-P5HA**

Indoor Intake air D.B.(°C)	Indoor Intake air W.B.(°C)	Outdoor intake air D.B.(°C)											
		35				40				45			
		CA	SHC(W)	SHF	P.C.	CA	SHC(W)	SHF	P.C.	CA	SHC(W)	SHF	P.C.
20	16	11,570	7,521	0.65	4.70	11,050	7,183	0.65	5.05	10,530	6,845	0.65	5.46
20	18	12,480	6,614	0.53	4.83	12,090	6,408	0.53	5.19	11,310	5,994	0.53	5.59
20	20	13,520	5,543	0.41	4.95	13,000	5,330	0.41	5.29	12,220	5,010	0.41	5.68
22	16	11,570	8,446	0.73	4.70	11,050	8,067	0.73	5.05	10,530	7,687	0.73	5.46
22	18	12,480	7,613	0.61	4.83	12,090	7,375	0.61	5.19	11,310	6,899	0.61	5.59
22	20	13,520	6,625	0.49	4.95	13,000	6,370	0.49	5.29	12,220	5,988	0.49	5.68
24	16	11,570	9,372	0.81	4.70	11,050	8,951	0.81	5.05	10,530	8,529	0.81	5.46
24	18	12,480	8,611	0.69	4.83	12,090	8,342	0.69	5.19	11,310	7,804	0.69	5.59
24	20	13,520	7,706	0.57	4.95	13,000	7,410	0.57	5.29	12,220	6,965	0.57	5.68
26	16	11,570	10,297	0.89	4.70	11,050	9,835	0.89	5.05	10,530	9,372	0.89	5.46
26	18	12,480	9,610	0.77	4.83	12,090	9,309	0.77	5.19	11,310	8,709	0.77	5.59
26	20	13,520	8,788	0.65	4.95	13,000	8,450	0.65	5.29	12,220	7,943	0.65	5.68
28	16	11,570	11,223	0.97	4.70	11,050	10,719	0.97	5.05	10,530	10,214	0.97	5.46
28	18	12,480	10,608	0.85	4.83	12,090	10,277	0.85	5.19	11,310	9,614	0.85	5.59
28	20	13,520	9,870	0.73	4.95	13,000	9,490	0.73	5.29	12,220	8,921	0.73	5.68
30	16	11,570	11,570	1.00	4.70	11,050	11,050	1.00	5.05	10,530	10,530	1.00	5.46
30	18	12,480	11,606	0.93	4.83	12,090	11,244	0.93	5.19	11,310	10,518	0.93	5.59
30	20	13,520	10,951	0.81	4.95	13,000	10,530	0.81	5.29	12,220	9,898	0.81	5.68
32	16	11,570	11,570	1.00	4.70	11,050	11,050	1.00	5.05	10,530	10,530	1.00	5.46
32	18	12,480	12,480	1.00	4.83	12,090	12,090	1.00	5.19	11,310	11,310	1.00	5.59
32	20	13,520	12,033	0.89	4.95	13,000	11,570	0.89	5.29	12,220	10,876	0.89	5.68
34	16	11,570	11,570	1.00	4.70	11,050	11,050	1.00	5.05	10,530	10,530	1.00	5.46
34	18	12,480	12,480	1.00	4.83	12,090	12,090	1.00	5.19	11,310	11,310	1.00	5.59
34	20	13,520	13,114	0.97	4.95	13,000	12,610	0.97	5.29	12,220	11,853	0.97	5.68

Notes CA : Capacity (W)
P.C. : Power consumption (kW)

SHC(W) : Sensible heat capacity
SHF : Sensible heat factor



Cooling capacity correction factors

Service Ref.	Refrigerant piping length (one way)									
	5m	10m	15m	20m	25m	30m	35m	40m	45m	50m
PCA-P3HA	1.00	0.981	0.968	0.952	0.940	0.925	0.913	0.900	0.886	0.874
PCA-P5HA	1.00	0.981	0.968	0.952	0.940	0.925	0.913	0.900	0.886	0.874

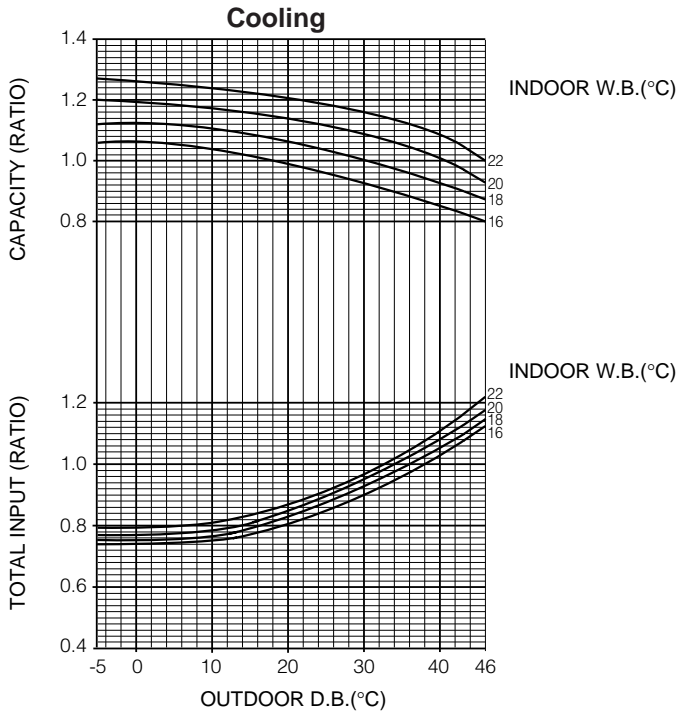

2) HEATING CAPACITY

Service Ref.	Indoor Intake air D.B.(°C)	Outdoor intake air W.B.(°C)											
		-10		-5		0		5		10		15	
		CA	P.C.	CA	P.C.	CA	P.C.	CA	P.C.	CA	P.C.	CA	P.C.
PCA-P3HA	15	5,842	2.01	6,348	2.22	7,084	2.56	9,292	3.07	10,488	3.41	11,684	3.68
	20	5,612	2.18	6,072	2.39	6,716	2.76	8,970	3.31	10,120	3.68	11,270	3.96
	25	5,428	2.32	5,888	2.59	6,440	3.00	8,464	3.51	9,752	3.94	10,856	4.25
PCA-P5HA	15	10,160	2.94	11,040	3.24	12,320	3.74	16,160	4.48	18,240	4.98	20,320	5.38
	20	9,760	3.19	10,560	3.49	11,680	4.03	15,600	4.83	17,600	5.38	19,600	5.78
	25	9,440	3.39	10,240	3.78	11,200	4.38	14,720	5.13	16,960	5.75	18,880	6.20

Notes CA : Capacity (W)

P.C. : Power consumption (kW)

Heating capacity correction factors

Service Ref.	Refrigerant piping length (one way)									
	5m	10m	15m	20m	25m	30m	35m	40m	45m	50m
PCA-P3HA	1.00	0.998	0.995	0.993	0.990	0.988	0.985	0.983	0.980	0.978
PCA-P5HA	1.00	0.998	0.995	0.993	0.990	0.988	0.985	0.983	0.980	0.978

Heating

- Correcting the capacity line influenced by frosting.
- Not correcting the capacity line influenced by frosting.

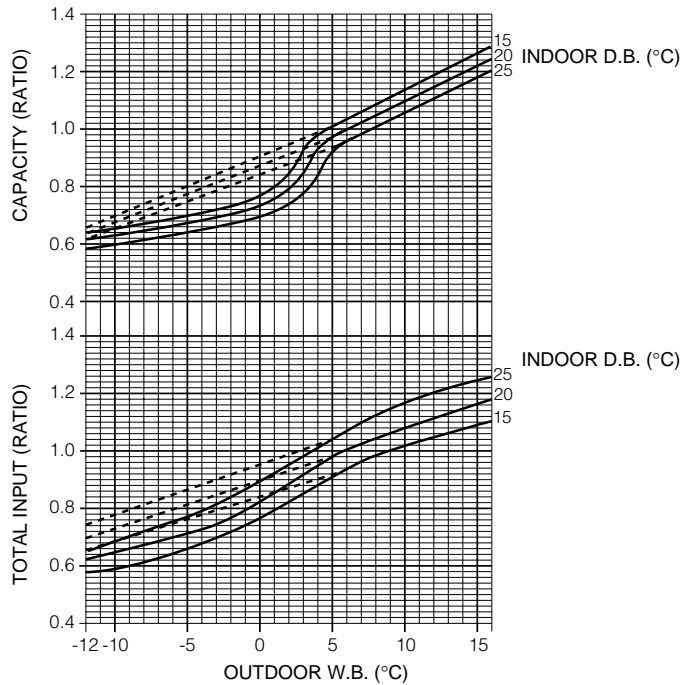

2. ELECTRICAL DATA

2.1. Heat pump type

Rating Conditions (ISO T1)

Indoor.....220V 50Hz Single phase

Outdoor....220V 50Hz Singel phase / 380V 50Hz 3 phase

Service Ref.	Indoor unit Outdoor unit	PCA-P3HA				PCA-P5HA	
		PUH-P3VGAA1.UK		PUH-P3YGAA1.UK		PUH-P5YGAA1.UK	
Mode		Cooling	Heating	Cooling	Heating	Cooling	Heating
Capacity (W)		7,500	9,200	7,500	9,200	13,000	16,000
Total Input (kW) (In + Out)		3.36	3.41	3.36	3.41	4.90	4.98
Indoor	Input (kW)	0.09	0.09	0.09	0.09	0.26	0.26
	Current (A)	0.44	0.44	0.44	0.44	1.24	1.24
Outdoor	Current (A)	15.31	15.54	5.23	5.32	7.22	7.46
	Starting current (A)	85	85	43	43	65.5	65.5

Indoor.....230V 50Hz Single phase

Outdoor....230V 50Hz Singel phase / 400V 50Hz 3 phase

Service Ref.	Indoor unit Outdoor unit	PCA-P3HA				PCA-P5HA	
		PUH-P3VGAA1.UK		PUH-P3YGAA1.UK		PUH-P5YGAA1.UK	
Mode		Cooling	Heating	Cooling	Heating	Cooling	Heating
Capacity (W)		7,500	9,200	7,500	9,200	13,000	16,000
Total Input (kW) (In + Out)		3.36	3.41	3.36	3.41	4.90	4.98
Indoor	Input (kW)	0.09	0.09	0.09	0.09	0.26	0.26
	Current (A)	0.43	0.43	0.43	0.43	1.19	1.19
Outdoor	Current (A)	14.63	14.85	4.96	5.04	6.85	7.07
	Starting current (A)	89	89	45	45	65.5	65.5

Indoor.....240V 50Hz Single phase

Outdoor....240V 50Hz Singel phase / 415V 50Hz 3 phase

Service Ref.	Indoor unit Outdoor unit	PCA-P3HA				PCA-P5HA	
		PUH-P3VGAA1.UK		PUH-P3YGAA1.UK		PUH-P5YGAA1.UK	
Mode		Cooling	Heating	Cooling	Heating	Cooling	Heating
Capacity (W)		7,500	9,200	7,500	9,200	13,000	16,000
Total Input (kW) (In + Out)		3.36	3.41	3.36	3.41	4.90	4.98
Indoor	Input (kW)	0.09	0.09	0.09	0.09	0.27	0.27
	Current (A)	0.41	0.41	0.41	0.41	1.14	1.14
Outdoor	Current (A)	14.02	14.24	4.78	4.86	6.61	6.82
	Starting current (A)	93	93	47	47	65.5	65.5

2.2. Cooling only type

Rating Conditions (ISO T1)

Indoor.....220V 50Hz Single phase

Outdoor....220V 50Hz Singel phase / 380V 50Hz 3 phase

Service Ref.	Indoor unit	PCA-P3HA		PCA-P5HA
	Outdoor unit	PU-P3VGAA1.UK	PU-P3YGAA1.UK	PU-P5YGAA1.UK
Mode		Cooling	Cooling	Cooling
Capacity (W)		7,500	7,500	13,000
Total Input (kW) (In + Out)		3.36	3.36	4.90
Indoor	Input (kW)	0.09	0.09	0.26
	Current (A)	0.44	0.44	1.24
Outdoor	Current (A)	15.31	5.23	7.22
	Starting current (A)	85	43	65.5

Indoor.....230V 50Hz Single phase

Outdoor....230V 50Hz Singel phase / 400V 50Hz 3 phase

Service Ref.	Indoor unit	PCA-P3HA		PCA-P5HA
	Outdoor unit	PU-P3VGAA1.UK	PU-P3YGAA1.UK	PU-P5YGAA1.UK
Mode		Cooling	Cooling	Cooling
Capacity (W)		7,500	7,500	13,000
Total Input (kW) (In + Out)		3.36	3.36	4.90
Indoor	Input (kW)	0.09	0.09	0.26
	Current (A)	0.43	0.43	1.19
Outdoor	Current (A)	14.63	4.96	6.85
	Starting current (A)	89	45	65.5

Indoor.....240V 50Hz Single phase

Outdoor....240V 50Hz Singel phase / 415V 50Hz 3 phase

Service Ref.	Indoor unit	PCA-P3HA		PCA-P5HA
	Outdoor unit	PU-P3VGAA1.UK	PU-P3YGAA1.UK	PU-P5YGAA1.UK
Mode		Cooling	Cooling	Cooling
Capacity (W)		7,500	7,500	13,000
Total Input (kW) (In + Out)		3.36	3.36	4.90
Indoor	Input (kW)	0.09	0.09	0.26
	Current (A)	0.41	0.41	1.14
Outdoor	Current (A)	14.02	4.78	6.61
	Starting current (A)	93	47	65.5

3. STANDARD OPERATION DATA

3.1 Heat pump type
Rating Conditions (ISO T1)

Service Ref.			PCA-P3HA		PCA-P5HA		
Mode			Cooling	Heating	Cooling	Heating	
Total	Capacity	W	7,500	9,200	13,000	16,000	
	Input	KW	3.36	3.41	4.90	4.98	
Electrical circuit	Indoor unit Service Ref.		PCA-P3HA		PCA-P5HA		
	Phase, Hz		1, 50		1, 50		
	Volts	V	230		230		
	Amperes	A	0.43	0.43	1.19	1.19	
	Outdoor unit Service Ref.		PUH-P3VGAA1.UK /PUH-P3YGAA1.UK		PUH-P5YGAA1.UK		
	Phase, Hz		1, 50/3, 50		3, 50		
	Volts	V	230/400		400		
	Amperes	A	14.63/4.96	14.85/5.04	6.85	7.07	
Refrigerant circuit	Discharge pressure	MPa (kgf/cm ²)	2.31 (23.5)	2.43 (24.8)	2.01 (20.5)	2.07 (21.1)	
	Suction pressure	MPa (kgf/cm ²)	0.45 (4.6)	0.39 (4.0)	0.46 (4.6)	0.38 (3.8)	
	Discharge temperature	°C	84	89	73	73	
	Condensing temperature	°C	59	62	54	55	
	Suction temperature	°C	2.9	-0.7	4.8	-0.3	
	Ref. pipe length	m	5	5	5	5	
Indoor side	Intake air temperature	D.B.	°C	27	20	27	20
		W.B.	°C	19	15	19	15
	Discharge air temperature	D.B.	°C	13	47	15	43
Outdoor side	Intake air temperature	D.B.	°C	35	7	35	7
		W.B.	°C	24	6	24	6
SHF			0.72	—	0.72	—	
BF			0.14	—	0.19	—	

The unit of pressure has been changed to Mpa on the international system of unit (SI unit system).
The converted score against the traditional unit system can be gotten according to the formula below.
1(Mpa)=10.2(kgf/cm²)

3.2 Cooling only type
Rating Conditions (ISO T1)

Service Ref.			PCA-P3HA	PCA-P5HA	
Mode			Cooling	Cooling	
Total	Capacity	W	7,500	13,000	
	Input	KW	3.36	4.90	
Electrical circuit	Indoor unit Service Ref.		PCA-P3HA	PCA-P5HA	
	Phase, Hz		1, 50	1, 50	
	Volts	V	230	230	
	Amperes	A	0.43	1.19	
	Outdoor unit Service Ref.		PU-P3VGAA ₁ .UK /PU-P3YGAA ₁ .UK	PU-P5YGAA ₁ .UK	
	Phase, Hz		1, 50/3, 50	3, 50	
	Volts	V	230/400	400	
	Amperes	A	14.63/4.96	6.85	
Refrigerant circuit	Discharge pressure	MPa (kgf/cm ²)	2.31 (23.5)	2.01 (20.5)	
	Suction pressure	MPa (kgf/cm ²)	0.45 (4.6)	0.46 (4.6)	
	Discharge temperature	°C	84	73	
	Condensing temperature	°C	59	54	
	Suction temperature	°C	2.9	4.8	
	Ref. pipe length	m	5	5	
Indoor side	Intake air temperature	D.B.	°C	27	27
		W.B.	°C	19	19
	Discharge air temperature	D.B.	°C	13	15
Outdoor side	Intake air temperature	D.B.	°C	35	35
		W.B.	°C	24	24
SHF			0.72	0.75	
BF			0.14	0.19	

The unit of pressure has been changed to Mpa on the international system of unit (SI unit system).
The converted score against the traditional unit system can be gotten according to the formula below.
1(Mpa)=10.2(kgf/cm²)

4. OUTLET AIR SPEED AND COVERAGE RANGE

		PCA-P3HA	PCA-P5HA
Air flow	m ³ /min	19	38
Air speed	m/sec	2.9	4.2
Coverage range	m	7.9	13.2

5. NOISE CRITERION CURVES

PCA-P3HA

NOTCH	SPL(dB)	LINE
Hi	38	○—○
Lo	34	●—●

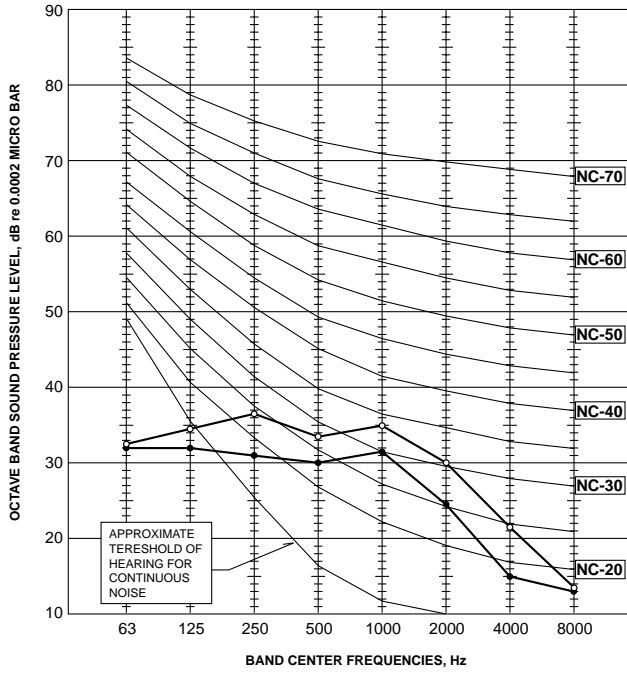

PCA-P5HA

NOTCH	SPL(dB)	LINE
Hi	50	○—○
Lo	44	●—●

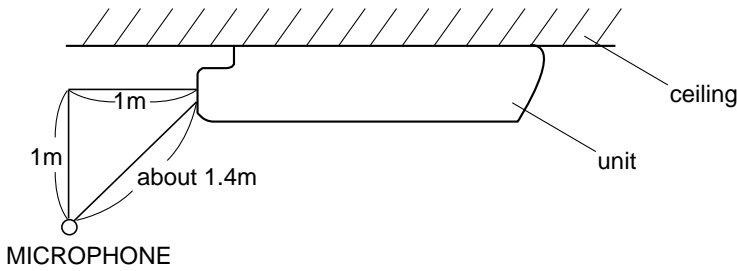
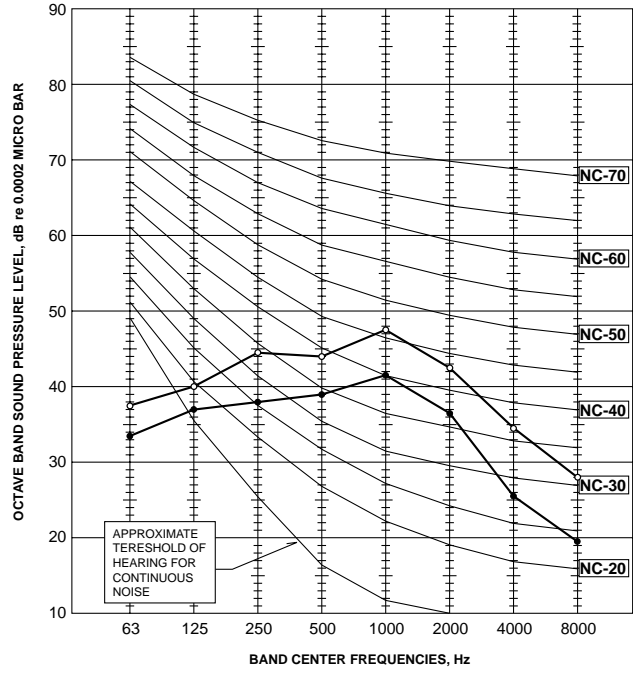

PCA-P3HA

Unit : mm

- ① Refrigerant-pipe connection (gas pipe side/flared connection : 5/8F)
 - ② Refrigerant-pipe connection (liquid pipe side/flared connection : 3/8F)
 - ③ Flexible hose(accessory) → Drainage pipe connection (VP-25; pipe outside diameter φ 32)
 - ④ Knock out hole for left Refrigerant-pipe arrangement
 - ⑤ Knock out hole for upper Refrigerant-pipe arrangement
 - ⑥ Knock out hole for wiring arrangement : 2- φ 27
 - ⑦ Terminal block (indoor/outdoor connecting line)
 - ⑧ Terminal block (remote controller)
 - ⑨ Knock out hole (duct for fresh air intake); 2- φ 200
- Option parts: duct flange (φ 200). model: PAC-SF28OF-E (1 pcs.)

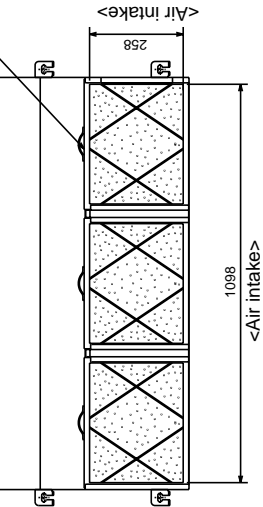
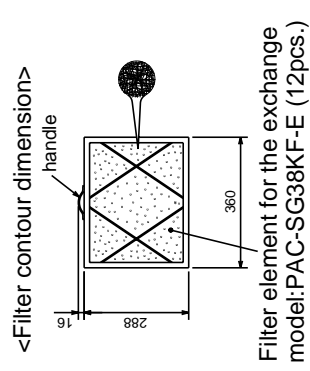
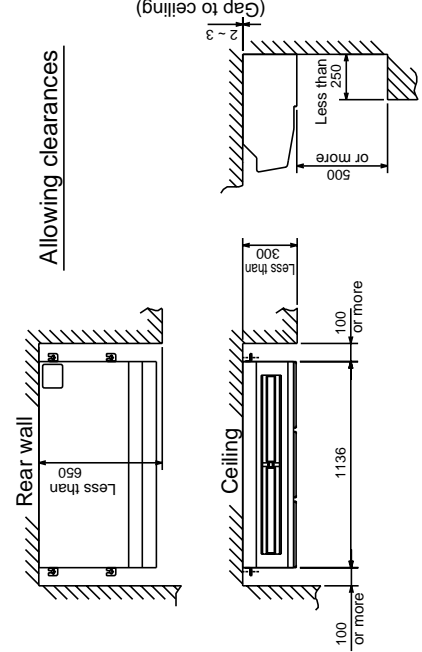
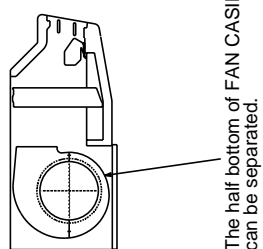
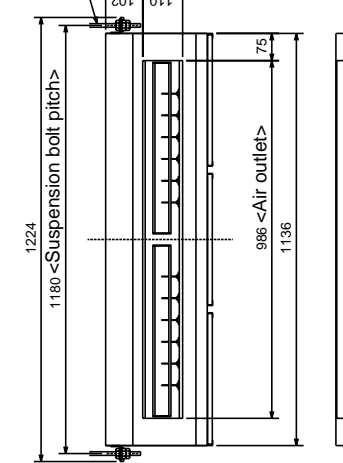
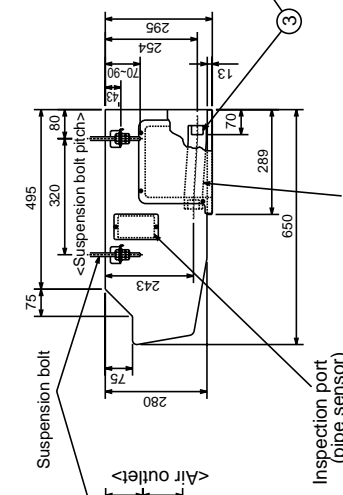
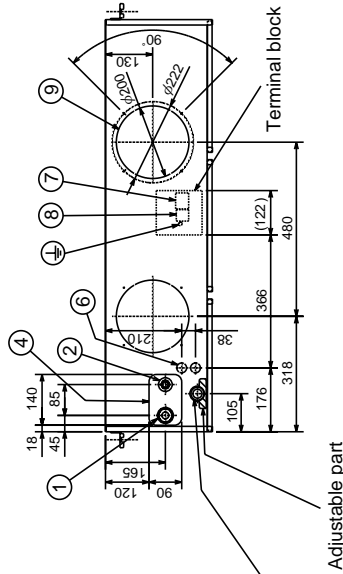
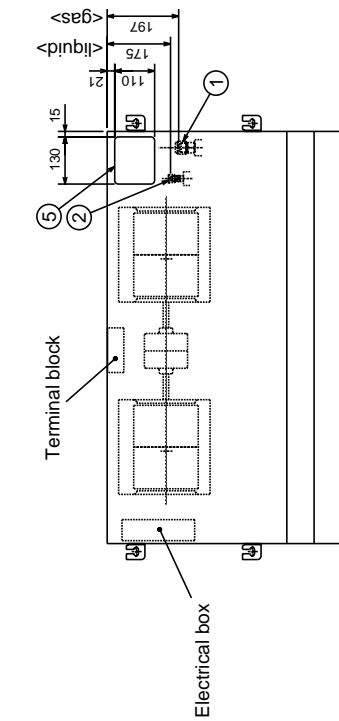

NOTES.
1. Use M10 or W3/8 screw for anchor bolt.

PCA-P5HA

- ① Refrigerant-pipe connection(gas pipe side/flared connection : 5/8F)
 - ② Refrigerant-pipe connection(liquid pipe side/flared connection : 3/8F)
 - ③ Flexible hose(accessory)→Drainage pipe connection(VP-25 : pipe outside diameter ϕ 32)
 - ④ Knock out hole for left Refrigerant-pipe arrangement
 - ⑤ Knock out hole for upper Refrigerant-pipe arrangement
 - ⑥ Knock out hole for wiring arrangement : 2- ϕ 27
 - ⑦ Terminal block(indoor/outdoor connecting line)
 - ⑧ Terminal block(remote controller)
 - ⑨ Knock out hole (duct for fresh air intake) : 2- ϕ 200
- Option parts:duct flange(ϕ 200). model: PAC-SF28OF-E(1 pcs.)

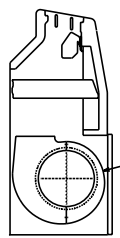
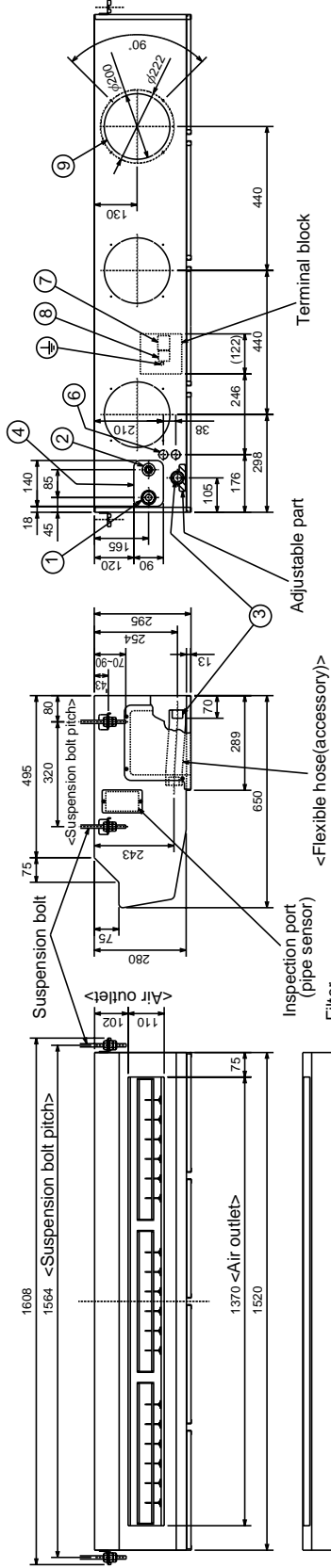
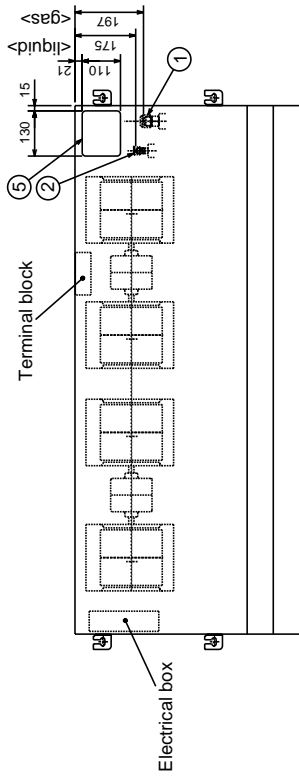

The half bottom of FAN CASING can be separated.

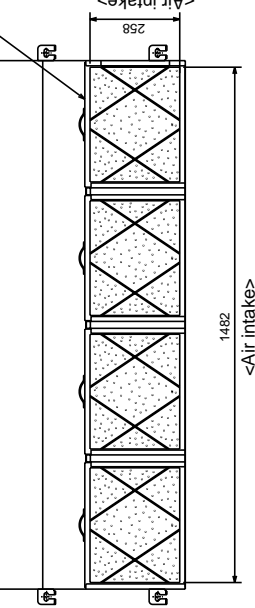
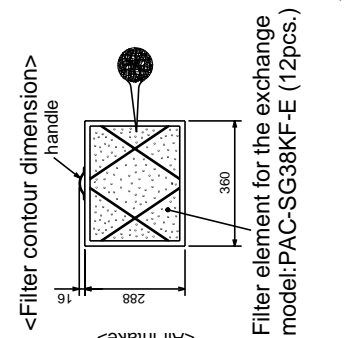
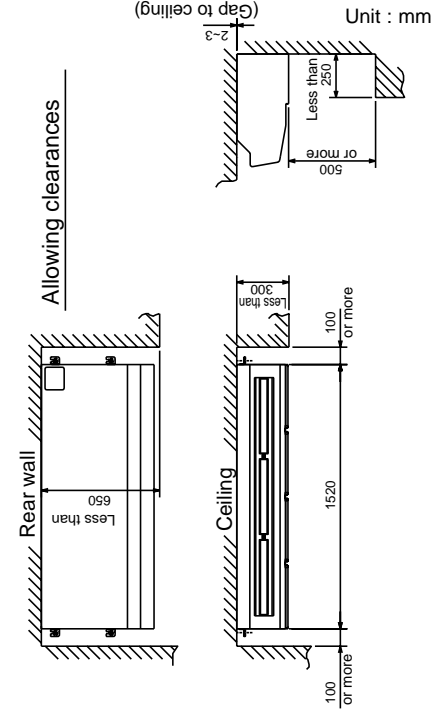

NOTES.
1. Use M10 or W3/8 screw for anchor bolt.

6

WIRING DIAGRAM

PCA-P3HA PCA-P5HA

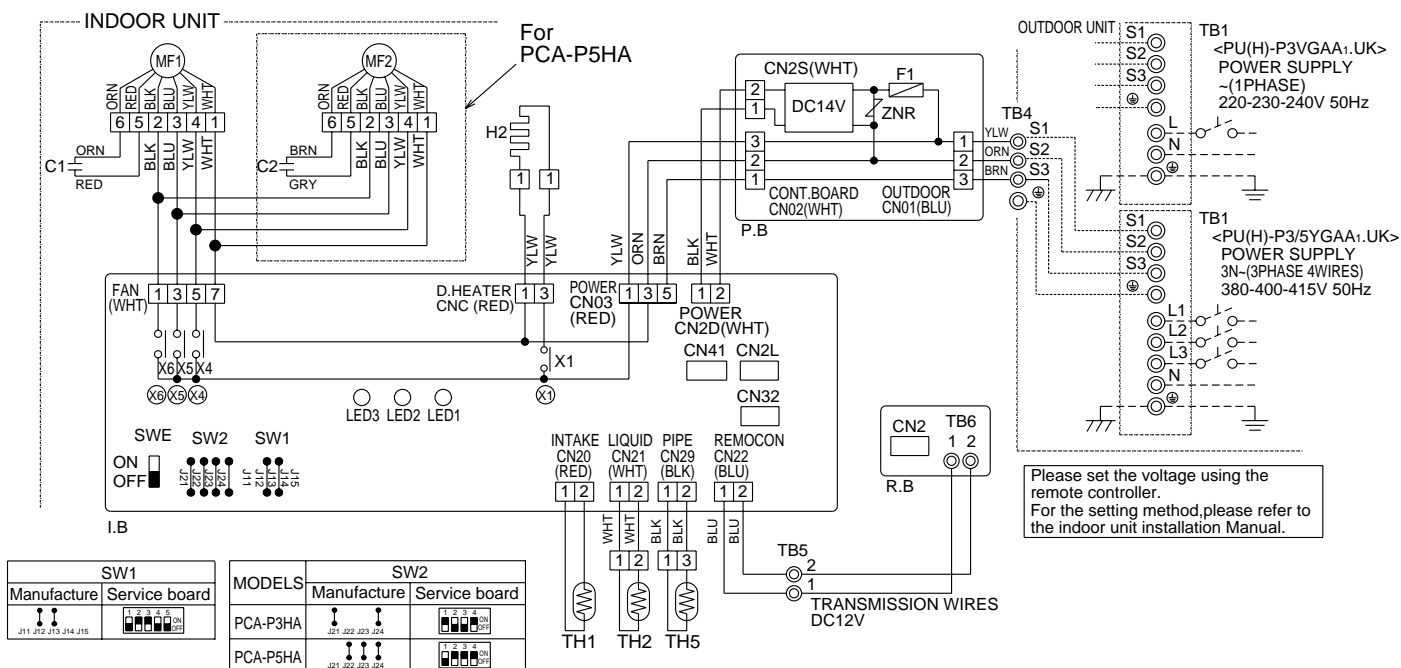

LEGEND

SYMBOL	NAME	SYMBOL	NAME
P.B	INDOOR POWER BOARD	MF1, MF2	FAN MOTOR
F1	FUSE(4A)	C1, C2	CAPACITOR(FAN MOTOR)
ZNR	VARIATOR	H2	DEW PREVENTION HEATER
I.B	INDOOR CONTROLLER BOARD	TB4	TERMINAL BLOCK(INDOOR/OUTDOOR CONNECTING LINE)
CN2L	CONNECTOR(LOSSNAY)	TB5	TERMINAL BLOCK(REMOTE CONTROLLER TRANSMISSION LINE)
CN32	CONNECTOR(REMOTE SWITCH)	TH1	ROOM TEMPERATUR THERMISTOR (0°C/15kΩ, 25°C/5.4kΩ DETECT)
CN41	CONNECTOR(HA TERMINAL-A)	TH2	PIPE TEMPERATUR THERMISTOR/LIQUID (0°C/15kΩ, 25°C/5.4kΩ DETECT)
LED2	POWER SUPPLY(I.B)	TH5	CONDENSER / EVAPORATOR TEMPERATUR THERMISTOR (0°C/15kΩ, 25°C/5.4kΩ DETECT)
LED3	TRANSMISSION(INDOOR-OUTDOOR)	R.B	REMOTE CONTROLLER BOARD
X1	RELAY(DEW PREVENTION HEATER)	CN2	CONNECTOR(PROGRAM TIMER)
X4	RELAY(FAN MOTOR)	TB6	TERMINAL BLOCK(REMOTE CONTROLLER TRANSMISSION LINE)
X5	RELAY(FAN MOTOR)		
X6	RELAY(FAN MOTOR)		
SW1	JUMPER WIRE(MODEL SELECTION)		
SW2	JUMPER WIRE(CAPACITY CODE)		
SWE	SWITCH(EMERGENCY OPERATION)		

NOTES:

- Since the outdoor side electric wiring may change be sure to check the outdoor unit electric wiring for servicing.
- Indoor and outdoor connecting wires are made with polarities, make wiring matching terminal numbers(S1, S2, S3).
- Symbols used in wiring diagram above are, : Connector, : Terminal (block).

[Servicing]

Fasten terminal of the terminal board "TB4" equips lock system.
To remove the fastened terminal, pull it while pressing the protruding portion(locking lever)of the terminal. The fastened terminal protruding portion should face upward.

Check code	Symptom
P1	Abnormality of room temperature thermistor(TH1).
P2	Abnormality of pipe temperature thermistor/Liquid(TH2).
P6	Freezing /overheating protection is working.
P8	Abnormality of pipe temperature.
P9	Abnormality of pipe temperature thermistor/ Condenser/Evaporator(TH5).
E0—E5	Abnormality of the signal transmission between remote controller and indoor unit.
E6—EF	Abnormality of the signal transmission between indoor unit and outdoor unit("EE" indicates abnormality of combination).
U*	Abnormality in outdoor unit. Refer to outdoor unit wiring diagram.
F*	Abnormality in outdoor unit. Refer to outdoor unit wiring diagram.
----	No trouble generated in the past.
FFFF	No corresponding unit.

Unit : mm

PCA-P3HA / PUH-3VGAA₁.UK, PUH-3YGAA₁.UK

<4-way valve solenoid coil>
 Heating : ON
 Cooling : OFF

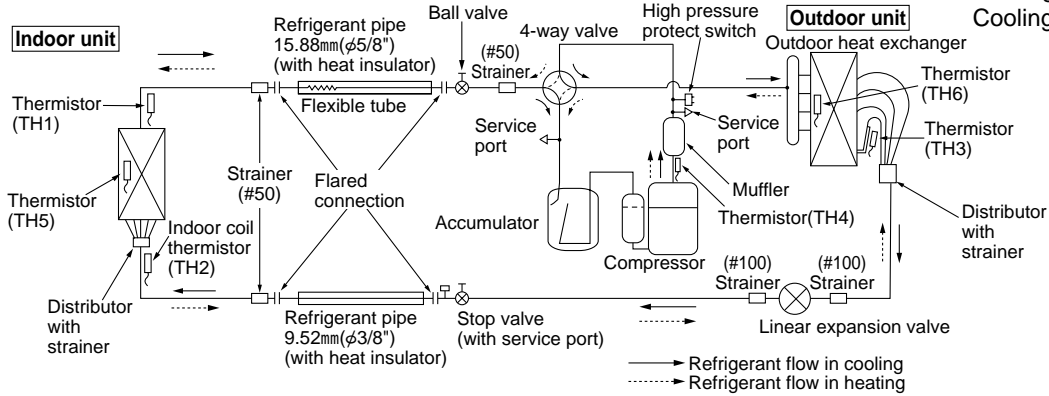

PCA-P5HA / PUH-5YGAA₁.UK

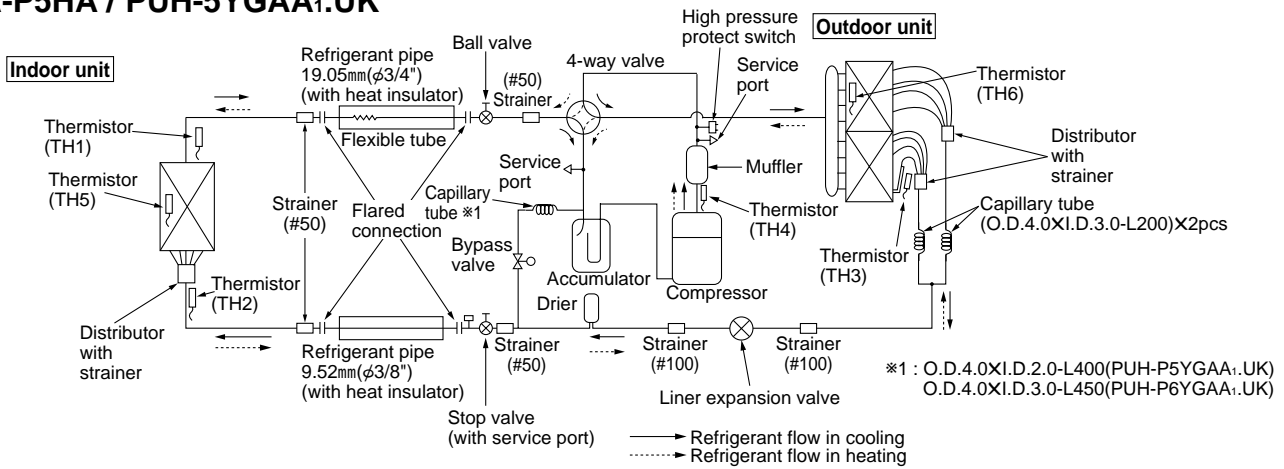

PCA-P3HA / PU-3VGAA₁.UK, PU-3YGAA₁.UK

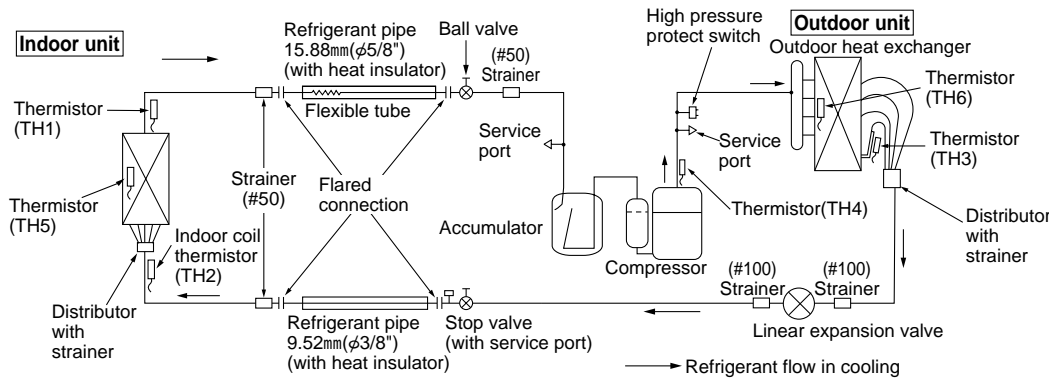

PCA-P5HA / PU-5YGAA₁.UK

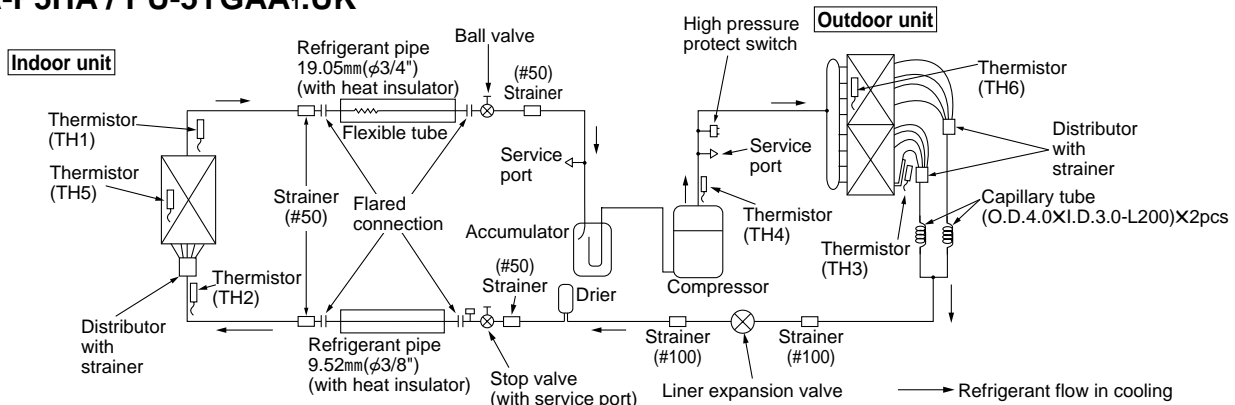

HOW TO CHECK THE PARTS

PCA-P3HA

PCA-P5HA

Parts name	Check points
Room temperature thermistor (TH1)	Disconnect the connector then measure the resistance using a tester. (Surrounding temperature 10°C ~30°C)
Pipe temperature thermistor (TH2)	
Condenser/Evaporator temperature thermistor (TH5)	
Fan motor	Measure the resistance between the terminals using a tester. (Winding temperature 20°C)

Normal	Abnormal	(Refer to the next page for a detail.)
4.3kΩ~9.6kΩ	Open or short	

Connector	Normal		Abnormal
	PCH-P3HA	PCH-P5HA	
White-Black	140.5Ω	75.6Ω	Open or short
Brown-Blue	15.4Ω	36.7Ω	
Blue-Yellow	28.5Ω	23.6Ω	
Yellow-Red	80.4Ω	47.8Ω	

Protector
 OPEN : 135±5°C
 CLOSE : 95±15°C

<Thermistor Characteristic graph>

Thermistor for lower temperature

Room temperature thermistor(TH1)
 Pipe temperature thermistor(TH2)
 Condenser/evaporator temperature thermistor(TH5)

Thermistor R₀=15kΩ ± 3%
 Fixed number of B=3480kΩ ± 2%

$$R_t = 15 \exp \left\{ 3480 \left(\frac{1}{273+t} - \frac{1}{273} \right) \right\}$$

0°C	15kΩ
10°C	9.6kΩ
20°C	6.3kΩ
25°C	5.4kΩ
30°C	4.3kΩ
40°C	3.0kΩ

< Thermistor for lower temperature >

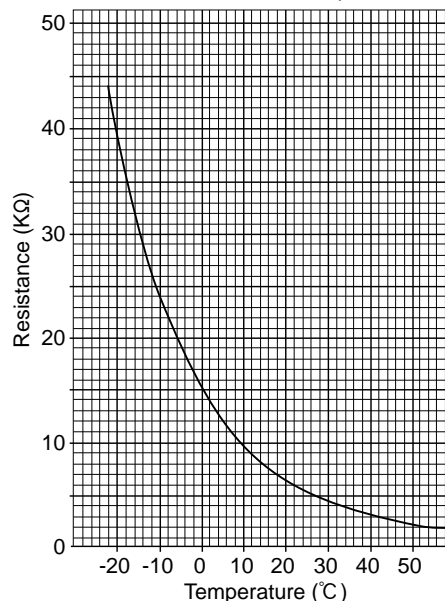

PCA-P5HA

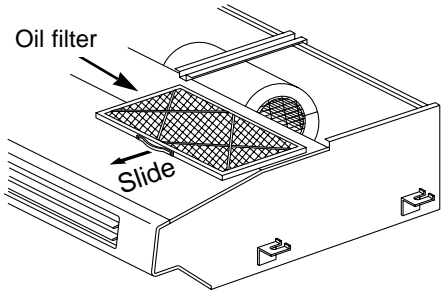
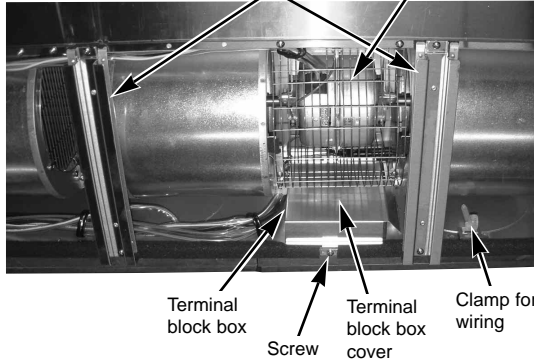
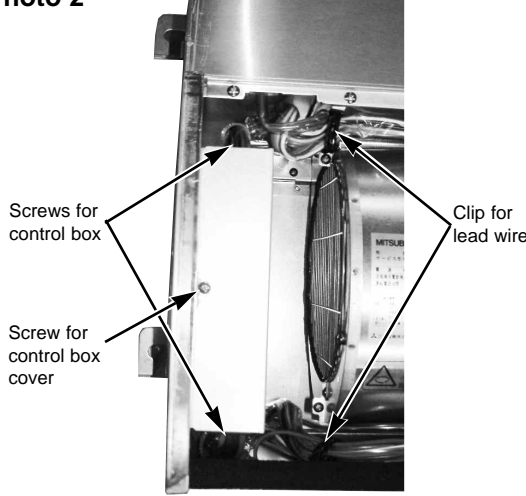
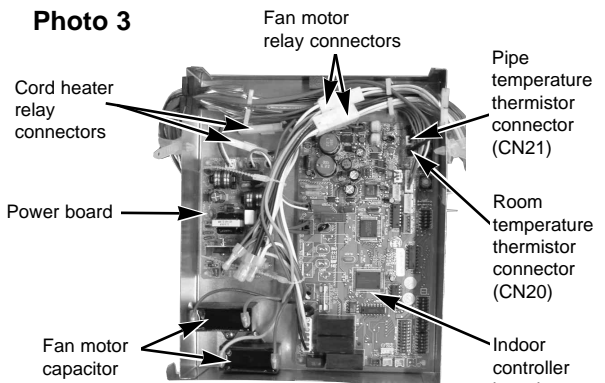
OPERATING PROCEDURE	PHOTOS&ILLUSTRATIONS
<p>1. Removing the oil filter (1) Slide the oil filter towards you to remove. (See figure 1.)</p>	<p>Figure 1</p> 
<p>2. Removing the terminal block box cover (1) Remove the oil filter. (See figure 1.) (2) Remove a screw for terminal block box cover, and remove the terminal block box cover. (See photo 1.)</p>	<p>Photo 1</p> 
<p>3. Removing the control box (1) Remove the oil filter. (See figure 1.) (2) Loosen a screw for control box cover to remove the control box cover. (See photo 2.) (3) Remove the lead wire from the 2 clips. (4) Remove the 2 white cord heater relay connectors (1PX2) and 2 fan motor relay connectors (6PX2) in the control box. (5) Remove the 2 screws for control box to slide the control box downward.</p> <p>Electrical parts in the control box</p> <ul style="list-style-type: none"> • Fan motor capacitor • Indoor controller board • Power board 	<p>Photo 2</p>  <p>Photo 3</p> 

OPERATING PROCEDURE

4. Removing the fan motor

- (1) Remove the oil filter. (See figure 1.)
- (2) Remove the control box cover. (See photo 2.)
- (3) Remove the room temperature thermistor connector (CN20) on the indoor controller board. (See photo 3.)
- (4) Remove a filter rail that is the nearest to the control box. (See photo 4.)
- (5) Remove the fan guard. (See photo 5.)
- (6) Remove the room temperature thermistor together with the holder at the right side of the casing.

5. Removing the fan motor and the sirocco fan

- (1) Remove the oil filter. (See figure 1.)
- (2) Remove the control box cover. (See photo 2.)
- (3) Remove the fan motor relay connectors (6P) in the control box. (See photo 3.)
- (4) Remove the 3 filter rails. (See photo 1, 4.)
- (5) Remove the fan guard. (See photo 5.)
- (6) Remove the lower casing. (See photo 6.)
- (7) Remove the green earth wire from the motor support. (See photo 7.)
- (8) Remove the 2 screws (M5 X 12) for motor support, and remove the left and right motor supports.
- (9) Remove the fan motor together with the sirocco fan.
- (10) Remove the 2 set screws (M6) to separate the fan motor from the sirocco fan.

PHOTOS&ILLUSTRATIONS

Photo 4

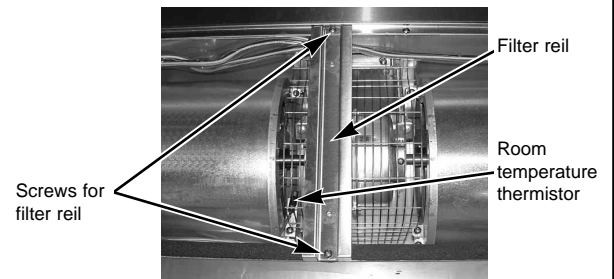

Photo 5

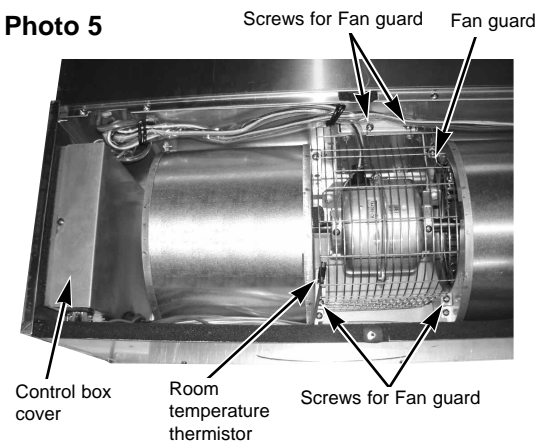

Photo 6

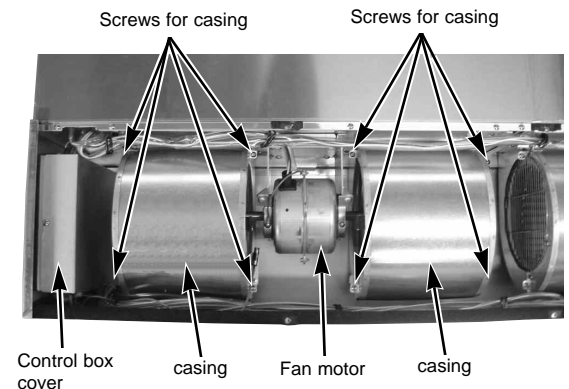
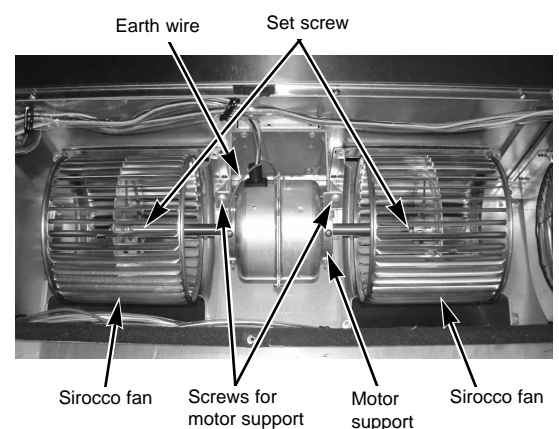

Photo 7



OPERATING PROCEDURE

6. Removing the pipe temperature thermistor

- (1) Remove the oil filter. (See figure 1.)
- (2) Remove the fan guard. (See photo 1.)
- (3) Remove the terminal block box cover.
- (4) Remove the white relay connector (2P) in the terminal block box. (See photo 8.)
- (5) Remove the service panel. (See photo 9.)
- (6) Remove the pipe temperature thermistor from the holder. (See photo 10.)

Caution for installation

When installing the pipe temperature thermistor, slack off its lead wire as shown in the photo. Otherwise, water trickled down the lead wire may splash on the connector and this could cause a short circuit of the connector.

PHOTOS

Photo 8

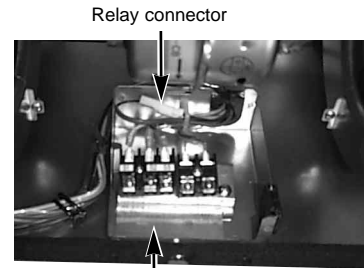

Photo 9

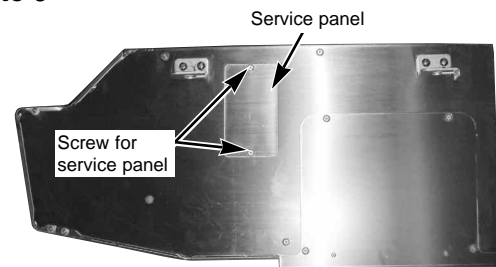
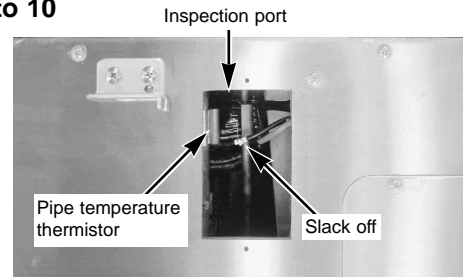

Photo 10



7. Removing the under panel

- (1) Remove the oil filter. (See figure 1.)
- (2) Remove the 3 filter rails. (See photo 1, 4.)
- (3) Remove the 12 screws (left: 1, right: 1, Bottom: 10) for under panel, and remove the under panel. (See photo 11.)

Photo 11

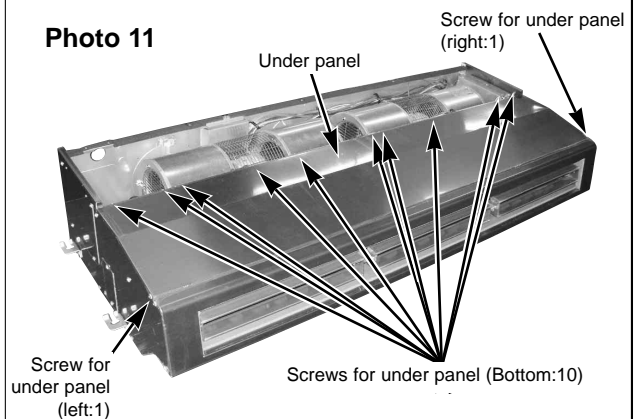

8. Removing the drain pan

- (1) Remove the oil filter. (See Figure 1)
- (2) Remove the 3 filter rails. (See photo 1, 4.)
- (3) Remove the under panel. (See photo 11.)
- (4) Pull the blue lead wire for cord heater towards you to slack off. (See photo 12.)
- (5) Remove the 3 screws at the center of the drain pan, and remove the drain pan.

(Note) Remove the drain pan carefully since the drain could remain in it.

Photo 12

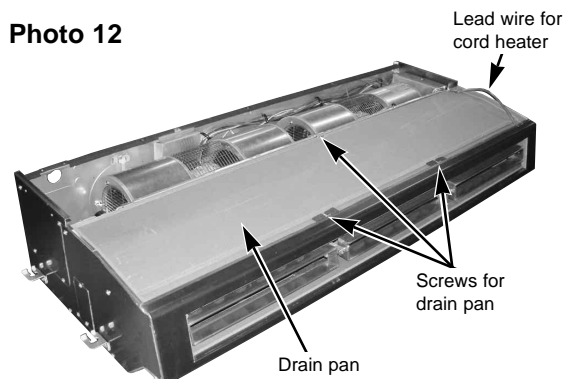



OPERATING PROCEDURE

9. Removing the guide vane

- (1) Remove the oil filter. (See figure 1.)
- (2) Remove the 3 filter rails. (See photo 1, 4.)
- (3) Remove the under panel. (See photo 11.)
- (4) Remove the drain pan. (See photo 12.)
- (5) Remove the 3 screws (4 X 10) for guide vane, and remove the guide vane. (See photo 13.)

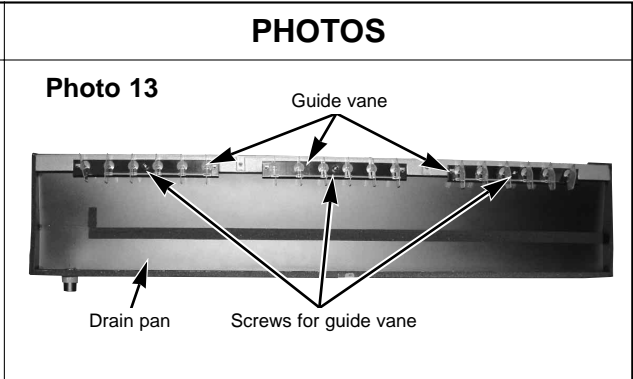

10. Removing the vane

- (1) Slide the vane to the center of the unit, and pull it towards you to remove. (See photo 14.)

Caution for installation

When installing the vane, check that its projection is on the left-rear side.

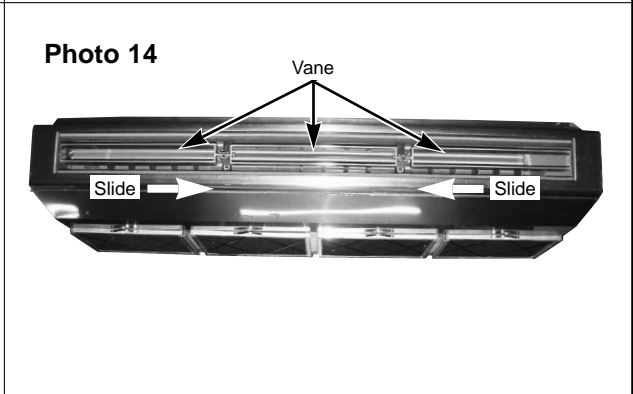

11. Removing the heat exchanger

- (1) Remove the oil filter. (See figure 1.)
- (2) Remove the 3 filter rails. (See photo 1, 4.)
- (3) Remove the under panel. (See photo 11.)
- (4) Remove the drain pan. (See photo 12.)
- (5) Remove the 2 screws (4 X 10) for pipe cover, and remove the pipe cover. (See photo 15.)
- (6) Remove the 3 screws (4 X 10, left: 2, right: 1) for heat exchanger. (See photo 15, 16.)
- (7) Remove the 2 screws (4 X 10) for heat exchanger at the top of the unit, and remove the heat exchanger. (See photo 17.)

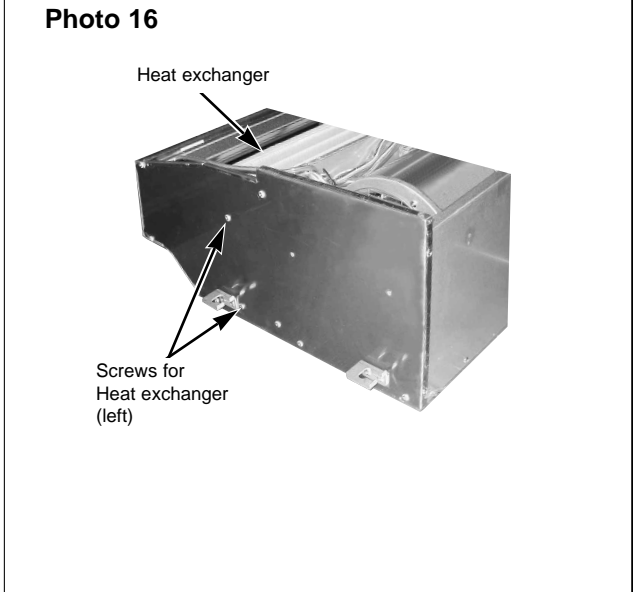
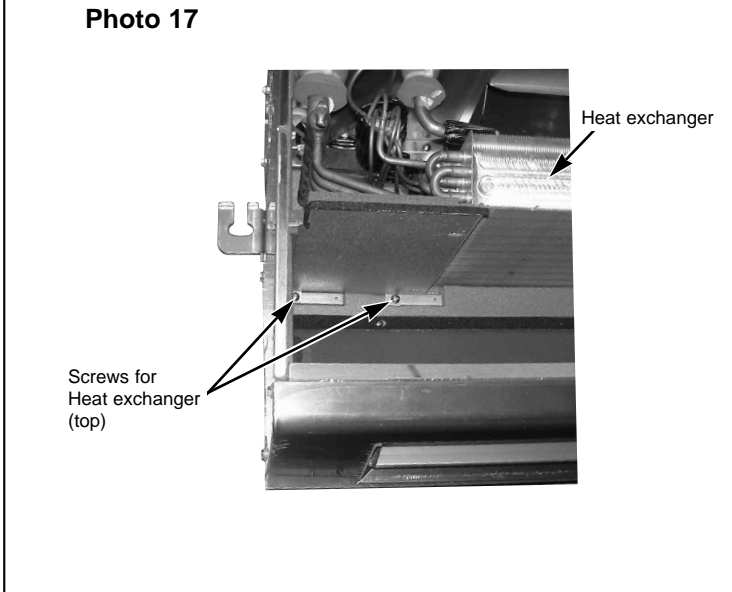
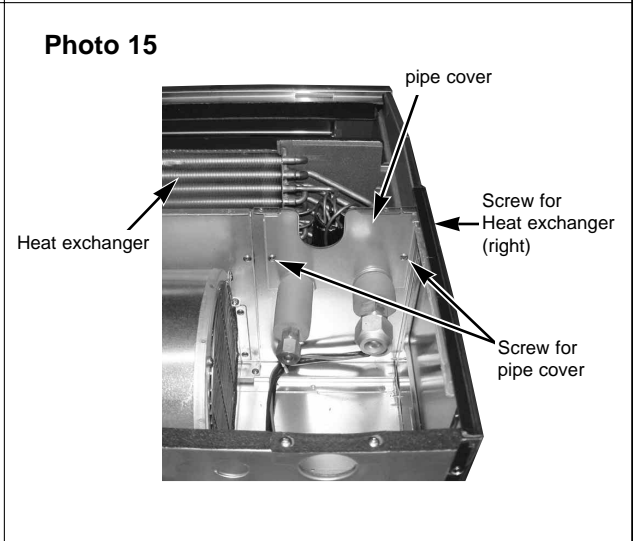

STRUCTURAL PART
PCA-P3HA
PCA-P5HA

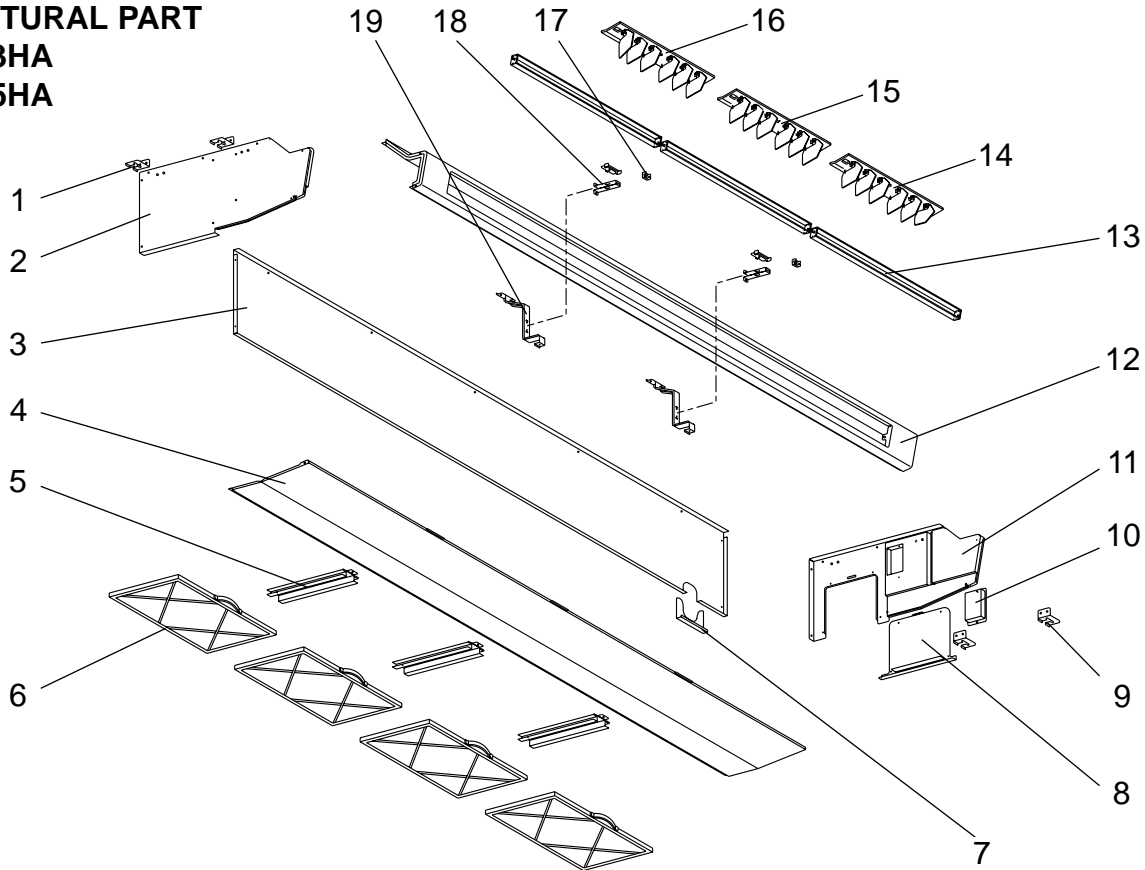

No.	Parts No.	Parts Name	Specifications	Q'ty / set		Remarks (Drawing No.)	Wiring Diagram Symbol	Recom- mended Q'ty	Price	
				PCA-					Unit	Amount
				P3HA	P5HA					
1	R01 13N 809	LEG-L		2	2					
2	R01 13N 662	SIDE PLATE-L		1	1					
3	T7W E02 676	REAR PANER		1						
	T7W E03 676	REAR PANER			1					
4	R01 12N 669	UNDER PANEL		1						
	R01 13N 669	UNDER PANEL			1					
5	R01 13N 503	FILTER RAIL		2	3					
6	R01 E05 500	OIL FILTER		3	4					
7	—	DRAIN HOSE SUPPORT		1	1	(BG00K145G02)				
8	R01 13N 667	SIDE COVER		1	1					
9	R01 13N 808	LEG-R		2	2					
10	R01 13N 668	SERVICE PANEL		1	1					
11	R01 13N 661	SIDE PLATE-R		1	1					
12	T7W E02 651	FRONT PANEL		1						
	T7W E03 651	FRONT PANEL			1					
13	R01 12N 002	VANE ASSY		2						
	R01 13N 002	VANE ASSY			3					
14	R01 13N 086	GUIDE VANE ASSY-6L		1	1					
15	R01 13N 087	GUIDE VANE ASSY-6C			1					
16	R01 13N 085	GUIDE VANE ASSY-6R		1	1					
17	R01 13N 533	VANE HOLDER		1	1					
18	—	VANE SUPPORT		1	2	(BG00K146G02)				
19	—	FRONT SUPPORT		1	2	(BG00T773G01)				

FAN AND HEATER PARTS
PCA-P3HA
PCA-P5HA

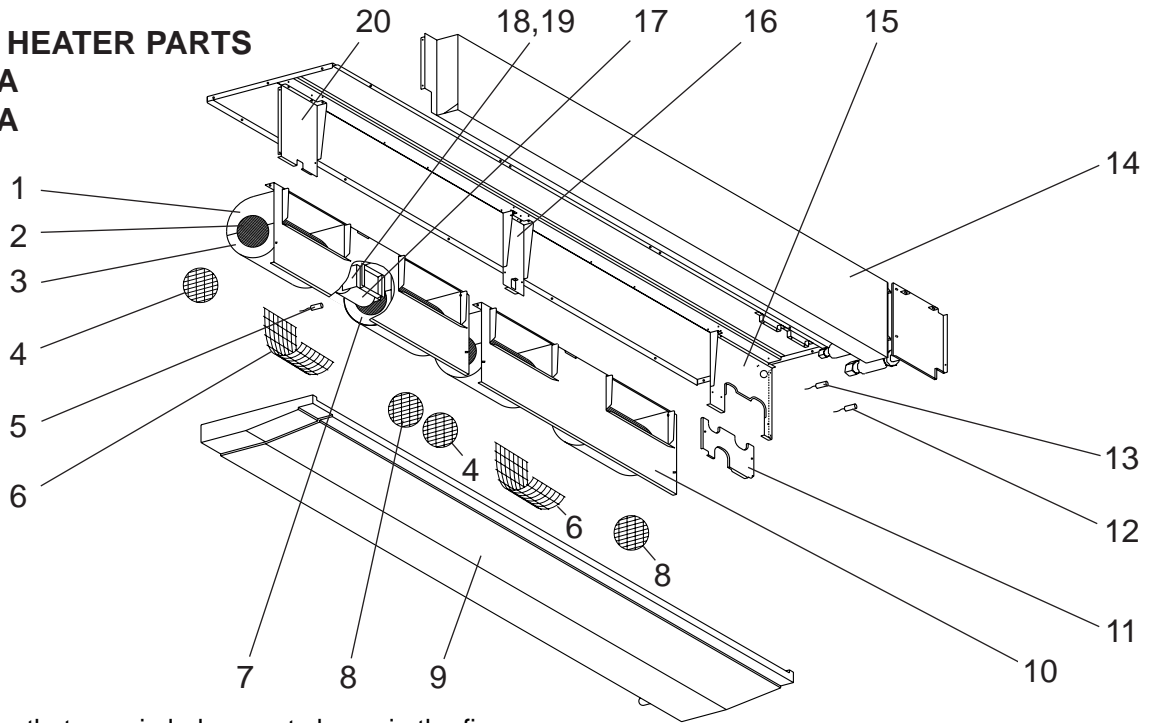

Part numbers that are circled are not shown in the figure.

No.	Parts No.	Parts Name	Specifications	Q'ty / set		Remarks (Drawing No.)	Wiring Diagram Symbol	Recom- mended Q'ty	Price	
				PCA-					Unit	Amount
				P3HA	P5HA					
1	R01 12N 110	T. CASING ASSY		2						
	R01 13N 110	T. CASING ASSY			4					
2	R01 12N 114	SIROCO FAN		2						
	R01 13N 114	SIROCO FAN			4					
3	T7W E02 111	UNDER CASING-L		1						
	T7W E03 111	UNDER CASING-L			2					
4	T7W E12 675	FAN GUARD-S		1	2					
5	R01 E51 202	ROOM TEMPERATUR TERMISTOR		1	1		TH1			
6	T7W E14 675	FAN GUARD-L		1						
	T7W E13 675	FAN GUARD-L			2					
7	T7W E00 111	UNDER CASING-R		1						
	T7W E01 111	UNDER CASING-R			2					
8	T7W E11 675	FAN GUARD-S		1	2					
9	R01 12N 529	DRAINPAN ASSY		1						
	R01 13N 529	DRAINPAN ASSY			1					
10	—	FAN PLATE		1		(BG00N756G15)				
	—	FAN PLATE			2	(BG00N756G14)				
11	—	PIPE SUPPORT		1	1	(BG02T500H04)				
12	R01 13N 202	PIPE TEMPERATURE TERMISTOR		1	1		TH2			
13	R01 E63 202	CONDENSER / EVAPORATOR TEMPERATURE TERMISTOR		1	1		TH5			
14	R01 H04 480	HEAT EXCHANGER		1						
	R01 E75 480	HEAT EXCHANGER			1					
15	—	FAN PLATE SUPPORT-R		1	1	(BG00N893G15)				
16	—	FAN PLATE SUPPORT-C		1	1	(BG00N893G14)				
17	T7W E20 762	FAN MOTOR	PA6V40-CB	1			MF1			
	T7W E21 762	FAN MOTOR	PA4V80-CA		2		MF1,2			
18	R01 45K 130	MOTOR LEG		1	2					
19	R01 83E 126	PIECE FOR MOTOR		1	2					
20	—	FAN PLATE SUPPORT-L		1	1	(BG00N893G13)				
21	R01 13N 521	PIPE COVER		1	1					
22	R01 13N 072	DRAIN HOSE COVER		1	1					
23	R01 811 105	RUBBER MOUNT		2	4					

ELECTRICAL PARTS
PCA-P3HA
PCA-P5HA

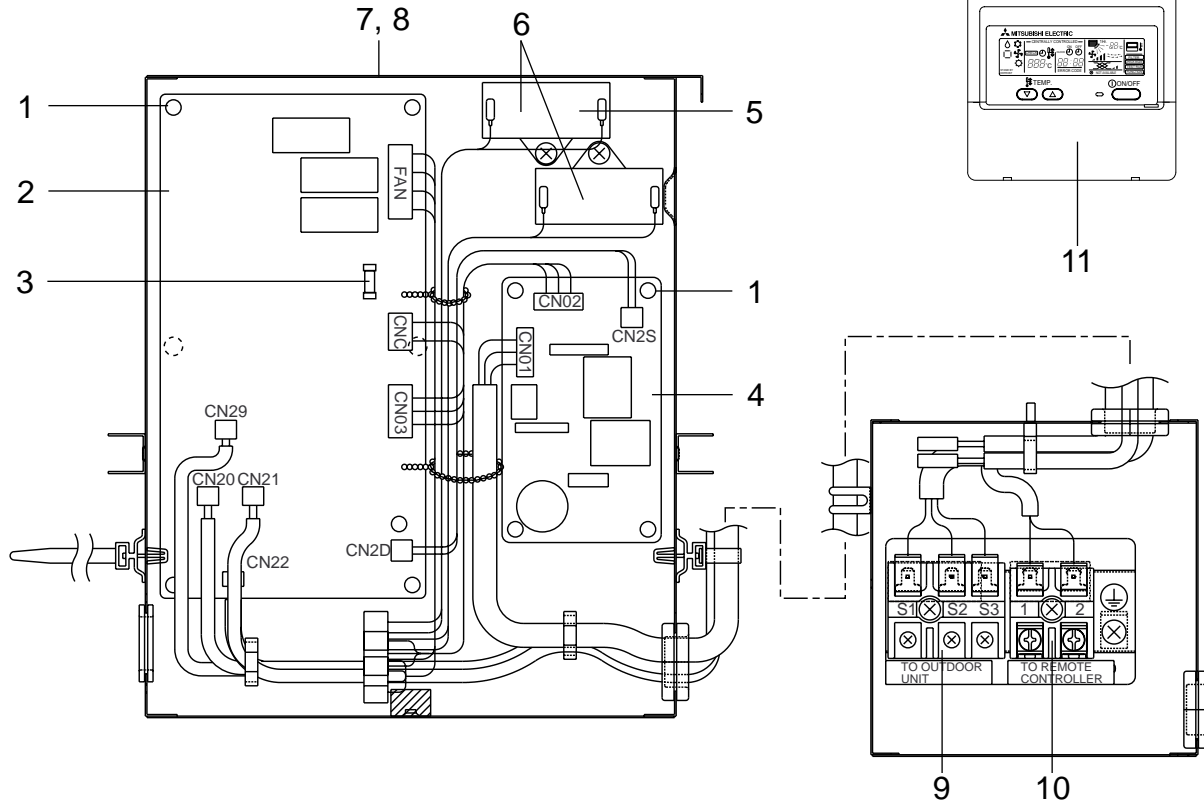

No.	Parts No.	Parts Name	Specifications	Q'ty / set		Remarks (Drawing No.)	Wiring Diagram Symbol	Recom- mended Q'ty	Price	
				PCA-					Unit	Amount
				P3HA	P5HA					
1	R01 18J 054	SUPPORT		9	9					
2	T7W E30 310	CONTROLLER BOARD		1	1		I.B			
3	R01 E00 239	FUSE	250V 4A	1	1					
4	T7W E01 313	POWER BOARD		1	1		P.B			
5	R01 A00 255	RUN CAPACITOR		1			C1			
6	R01 576 255	RUN CAPACITOR			2		C1,C2			
7	—	CONTROL BOX COVER		1	1	(BG02N713H05)				
8	—	CONTROL BOX		1	1	(BG00T759G12)				
9	R01 17J 246	TERMINAL BLOCK	3P(S1, S2, S3)	1	1		TB4			
10	R01 556 246	TERMINAL BLOCK	2P(1, 2)	1	1		TB5			
11	—	REMOTE CONTROLLER		1	1		R.B			

1. TIMER

Part No.	PAC-SC32PTA (with set back function)
Model Name	Program timer

1-1. Program timer specifications

Part name	Program timer
Parts No.	PAC-SC32PTA
Exterior dimensions (inch)	5-4/32X4-23/32X23/32 (130X120X18mm)
Installation	Wall mount
Type of clock	Quartz
Clock accuracy	±50 second / month at 25°C
Display-Time	Liquid crystal display
-Week	Liquid crystal display
-Timer setting unit	Liquid crystal display
Program cycle	24 hours
Timer setting unit	30 minutes
No. of set points	48 / day
Power rating	5V DC ±5% (Supplied by Remote Controller)

1-2. Feature of program timer

(1) Daily timer function

Daily timer can be set in 30 minutes units for up to 24 hours.
Each unit can be set for unit ON, unit OFF, or setback operation.

(2) Setback operation

Set back operation is useful for reducing running costs

e.g. At a hotel with a 24-hour system

8:00~23:00 Cooling operation with set temperature at 26°C

23:00~8:00 Setback operation with 2 degrees of setback

As shown in the chart on the right, the set temperature rises 2 degrees automatically during the setback operation. When the setback operation ends, normal operation will begin.

(3) Weekly timer function

Daily timer function can apply to each day of the week.

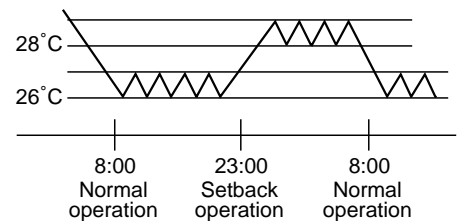

1-3. How to connect program timer

- (1) Install the program timer next to the remote controller the same way as the remote controller is installed.
- (2) Connect the program timer and the remote controller with a 5-wire cable as shown in the figure below

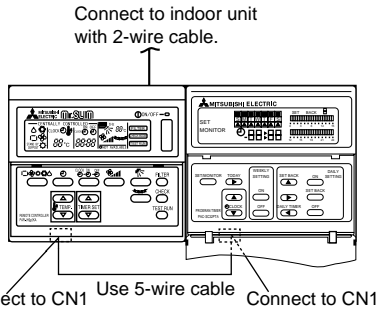

NOTE: While the program timer is connected to the remote controller, the 24hour ON/OFF timer on the remote controller will not operate.

1-4. Names and functions <PAC-SC32PTA>

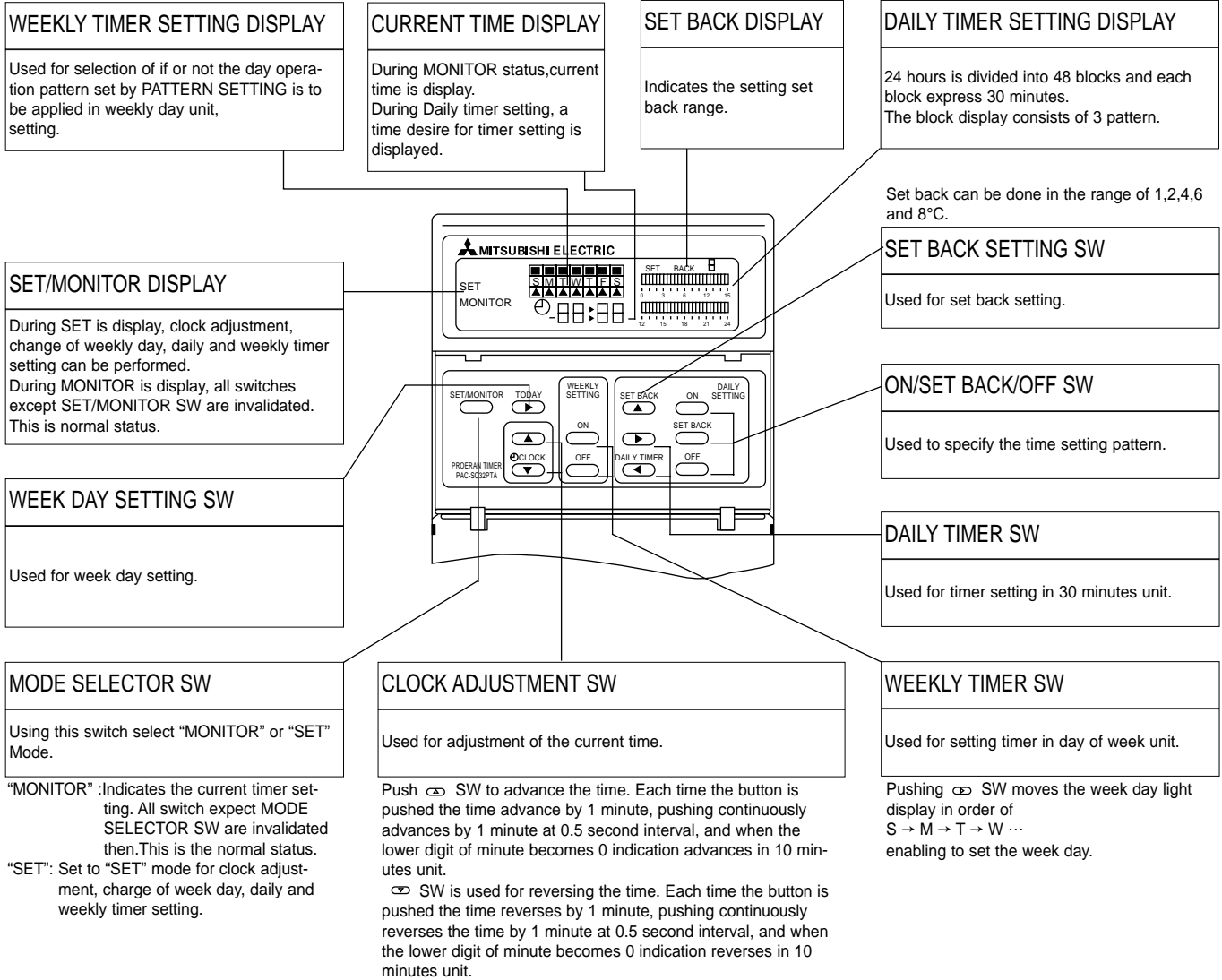

2. Duct flange for fresh air

Part No.	PAC-SF28OF-E
Applied Service Ref.	PCA-P3HA, PCA-P5HA

3. Filter element

Part No.	PAC-SG38KF-E
Applied Service Ref.	PCA-P3HA, PCA-P5HA

4. Decoration cover (Front + Suspending bracket cover)

Part No.	PAC-SF81KC-E	PAC-SF82KC-E
Applied Service Ref.	PCA-P3HA	PCA-P5HA

5. Remote sensor

Part No.	PAC-SE41TS-E
Applied Service Ref.	PCA-P3HA, PCA-P5HA

6. Remote operation adapter

Part No.	PAC-SF40RM-E
Applied Service Ref.	PCA-P3HA, PCA-P5HA

7. Remote ON/OFF adapter

Part No.	PAC-SF55RA-E
Applied Service Ref.	PCA-P3HA, PCA-P5HA

Mr. SLIMTM

 **MITSUBISHI ELECTRIC CORPORATION**

HEAD OFFICE : MITSUBISHI DENKI BLDG., 2-2-3, MARUNOUCHI, CHIYODA-KU TOKYO 100-8310, JAPAN
