



AIR-COOLED SPLIT-TYPE
PACKAGED AIR CONDITIONERS

Changes for the Better

2003

TECHNICAL & SERVICE MANUAL

<Indoor unit>

HEAT PUMP **Models**
PEH-P8MYA, PEH-P10MYA
PEH-P16MYA, PEH-P20MYA

For use with the R407C

Contents

	Page
1 PRECAUTIONS FOR DEVICES THAT USE R407C REFRIGERANT	1
[1] Storage of Piping Material	2
[2] Piping Machining	3
[3] Necessary Apparatus and Materials and Notes on Their Handling	4
[4] Brazing	5
[5] Airtightness Test.....	6
[6] Vacuuming	6
[7] Charging of Refrigerant	7
2 PART NAMES AND FUNCTIONS	8
3 SPECIFICATIONS	10
4 PART NAMES AND FUNCTIONS	14
5 ELECTRICAL WIRING DIAGRAM	19
6 TECHNICAL DATA TO MEET LVD	21
[1] Capacity/Input Ratio against Changes in Room Airflow Rate	21
[2] Bypass Factor Curves	23
[3] Cooling Sensible Heating Capacity Table	24
[4] Airflow Characteristic Curves	25
[5] Center of Gravity (Indoor unit)	25
[6] NC Curve (Indoor unit)	27
7 SERVICE DATA	29
[1] Appearance of Equipment	29
[2] Internal Construction	30
[3] Refrigerant Circuit	30
8 FUNCTION OF SWITCH ON INDOOR CIRCUIT BOARD	31
[1] DIP SW1 for model Selection (DIP SW1 has been set at factory)	31
[2] DIP SW2 for Capacity Setting (DIP SW2 has been set at factory)	31
[3] DIP SWE for Emergency Operation	31
9 TEST RUN	32
[1] Before test run	32
[2] Test run procedures	32
[3] Self-diagnosis	34
[4] Remote controller diagnosis	36

1 PRECAUTIONS FOR DEVICES THAT USE R407C REFRIGERANT

Caution

Do not use the existing refrigerant piping.

- The old refrigerant and refrigerator oil in the existing piping contains a large amount of chlorine which may cause the refrigerator oil of the new unit to deteriorate.

Use refrigerant piping made of phosphorus deoxidized copper and copper alloy seamless pipes and tubes". In addition, be sure that the inner and outer surfaces of the pipes are clean and free of hazardous sulphur, oxides, dust/dirt, shaving particles, oils, moisture, or any other contaminant.

- Contaminants on the inside of the refrigerant piping may cause the refrigerant residual oil to deteriorate.

Store the piping to be used during installation indoors and keep both ends of the piping sealed until just before brazing. (Store elbows and other joints in a plastic bag.)

- If dust, dirt, or water enters the refrigerant cycle, deterioration of the oil and compressor trouble may result.

Use ester oil, ether oil or alkylbenzene (small amount) as the refrigerator oil to coat flares and flange connections.

- The refrigerator oil will degrade if it is mixed with a large amount of mineral oil.

Use liquid refrigerant to seal the system.

- If gas refrigerant is used to seal the system, the composition of the refrigerant in the cylinder will change and performance may drop.

Do not use a refrigerant other than R407C.

- If another refrigerant (R22, etc.) is used, the chlorine in the refrigerant may cause the refrigerator oil to deteriorate.

Use a vacuum pump with a reverse flow check valve.

- The vacuum pump oil may flow back into the refrigerant cycle and cause the refrigerator oil to deteriorate.

Do not use the following tools that have been used with conventional refrigerants.

(Gauge manifold, charge hose, gas leak detector, reverse flow check valve, refrigerant charge base, vacuum gauge, refrigerant recovery equipment)

- If the conventional refrigerant and refrigerator oil are mixed in the R407C, the refrigerant may deteriorate.
- If water is mixed in the R407C, the refrigerator oil may deteriorate.
- Since R407C does not contain any chlorine, gas leak detectors for conventional refrigerants will not react to it.

Do not use a charging cylinder.

- Using a charging cylinder may cause the refrigerant to deteriorate.

Be especially careful when managing the tools.

- If dust, dirt, or water gets in the refrigerant cycle, the refrigerant may deteriorate.

If the refrigerant leaks, recover the refrigerant in the refrigerant cycle, then recharge the cycle with the specified amount of the liquid refrigerant indicated on the air conditioner.

- Since R407C is a nonazeotropic refrigerant, if additionally charged when the refrigerant leaked, the composition of the refrigerant in the refrigerant cycle will change and result in a drop in performance or abnormal stopping.

[1] Storage of Piping Material

(1) Storage location



Store the pipes to be used indoors. (Warehouse at site or owner's warehouse)
Storing them outdoors may cause dirt, waste, or water to infiltrate.

(2) Pipe sealing before storage

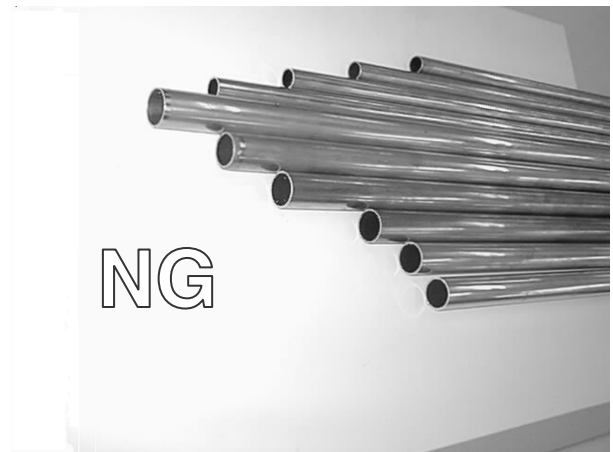
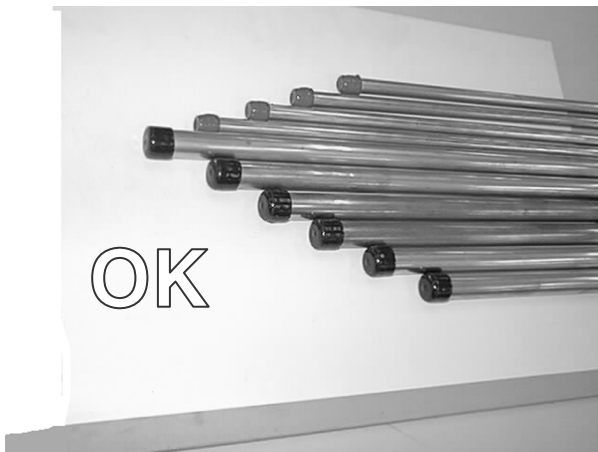

Both ends of the pipes should be sealed until immediately before brazing.
Wrap elbows and T's in plastic bags for storage.

* The new refrigerator oil is 10 times more hygroscopic than the conventional refrigerator oil (such as Suniso). Water infiltration in the refrigerant circuit may deteriorate the oil or cause a compressor failure. Piping materials must be stored with more care than with the conventional refrigerant pipes.

[2] Piping Machining

Use ester oil, ether oil or alkylbenzene (small amount) as the refrigerator oil to coat flares and flange connections.

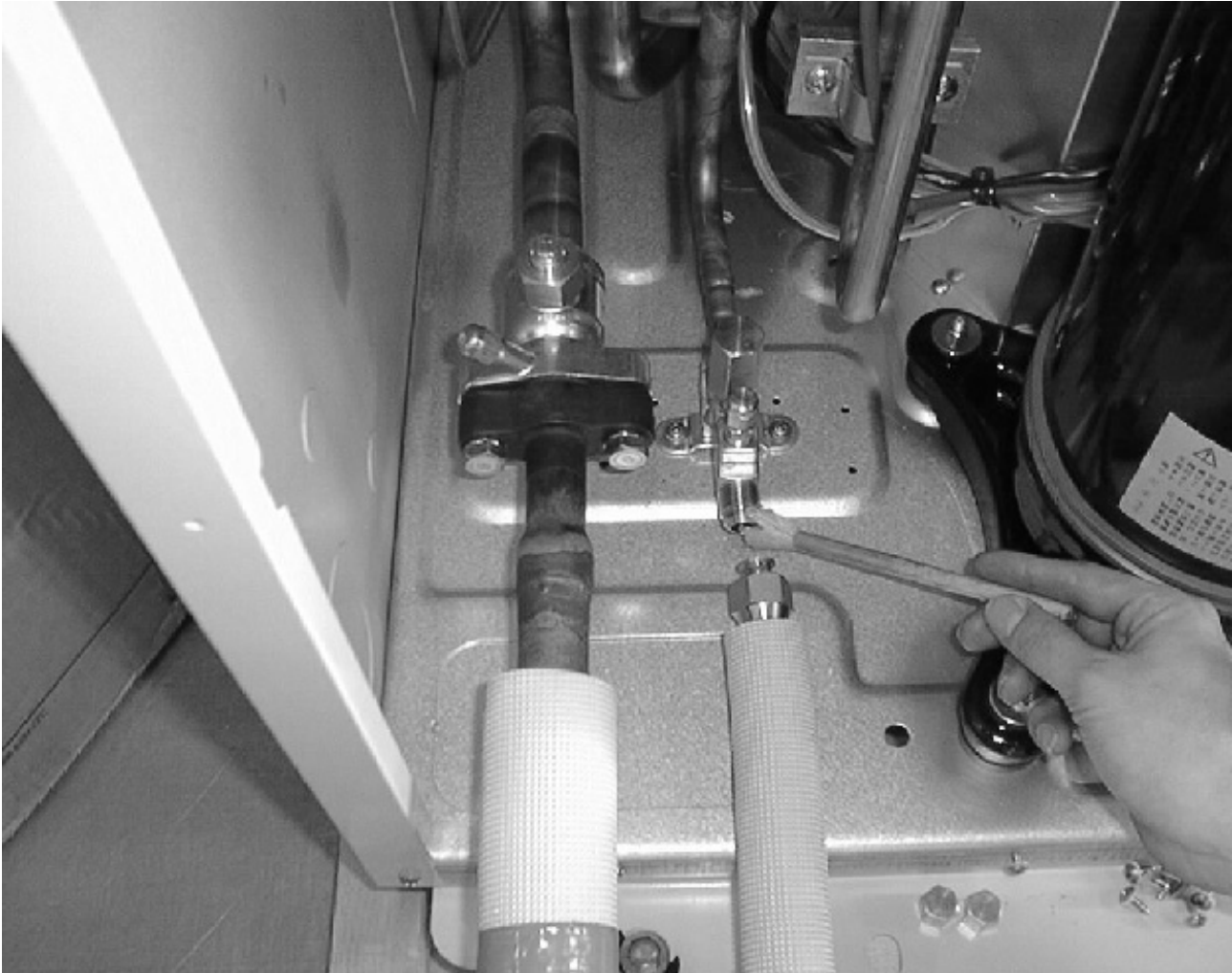

Use only the necessary minimum quantity of oil.

Reason:

1. The refrigerator oil used for the equipment is highly hygroscopic and may introduce water inside.

Notes:

- Introducing a great quantity of mineral oil into the refrigerant circuit may also cause a compressor failure.
- Do not use oils other than ester oil, ether oil or alkylbenzene.

[3] Necessary Apparatus and Materials and Notes on Their Handling

The following tools should be marked as dedicated tools for R407C.

<<Comparison of apparatus and materials used for R407C and for R22>>

Apparatus Used	Use	R22	R407C
Gauge manifold	Evacuating, refrigerant filling	Current product	⊙
Charging hose	Operation check	Current product	⊙
Charging cylinder	Refrigerant charging	Current product	⊙ Do not use
Gas leakage detector	Gas leakage check	Current product	⊙ Shared with R134a
Refrigerant collector	Refrigerant collection	R22	⊙ For R407C use only
Refrigerant cylinder	Refrigerant filling	R22	⊙ Identification of dedicated use for R407C: Record refrigerant name and put brown belt on upper part of cylinder.
Vacuum pump	Vacuum drying	Current product	△ Can be used by attaching an adapter with a check valve.
Vacuum pump with a check valve		Current product	△
Flare tool	Flaring of pipes	Current product	△
Bender	Bending of pipes	Current product	△
Application oil	Applied to flared parts	Current product	⊙ Ester oil or Ether oil or Alkybenzene (Small amount)
Torque wrench	Tightening of flare nuts	Current product	△
Pipe cutter	Cutting of pipes	Current product	△
Welder and nitrogen cylinder	Welding of pipes	Current product	△
Refrigerant charging meter	Refrigerant charging	Current product	△
Vacuum gauge	Checking the vacuum degree	Current product	△

Symbols: ⊙ To be used for R407C only.

△ Can also be used for conventional refrigerants.

Tools for R407C must be handled with more care than those for conventional refrigerants. They must not come into contact with any water or dirt.

[4] Brazing

No changes from the conventional method, but special care is required so that foreign matter (ie. oxide scale, water, dirt, etc.) does not enter the refrigerant circuit.

Example: Inner state of brazed section

When non-oxide brazing was not used

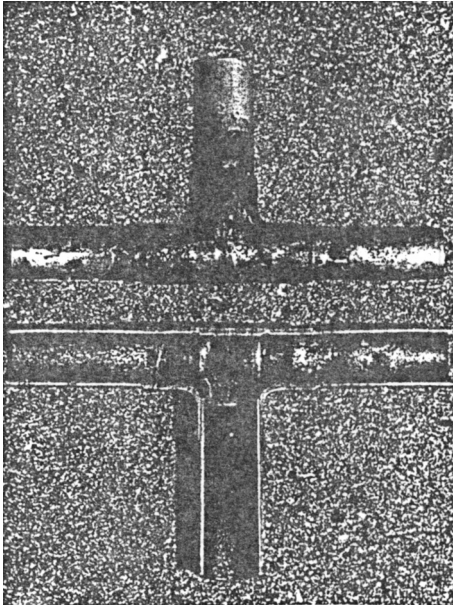

When non-oxide brazing was used

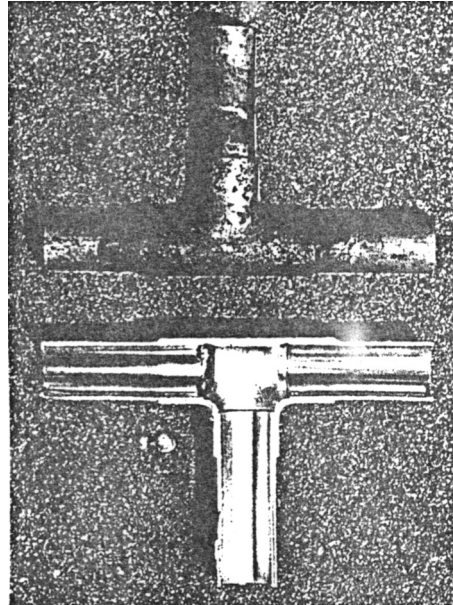

Items to be strictly observed:

1. Do not conduct refrigerant piping work outdoors on a rainy day.
2. Apply non-oxide brazing.
3. Use a brazing material (BCuP-3) which requires no flux when brazing between copper pipes or between a copper pipe and copper coupling.
4. If installed refrigerant pipes are not immediately connected to the equipment, then braze and seal both ends of them.

Reasons:

1. The new refrigerant oil is 10 times more hygroscopic than the conventional oil. The probability of a machine failure if water infiltrates is higher than with conventional refrigerant oil.
2. A flux generally contains chlorine. A residual flux in the refrigerant circuit may generate sludge.

Note:

- Commercially available antioxidants may have adverse effects on the equipment due to its residue, etc. When applying non-oxide brazing, use nitrogen.

[5] Airtightness Test

No changes from the conventional method. Note that a refrigerant leakage detector for R22 cannot detect R407C leakage.

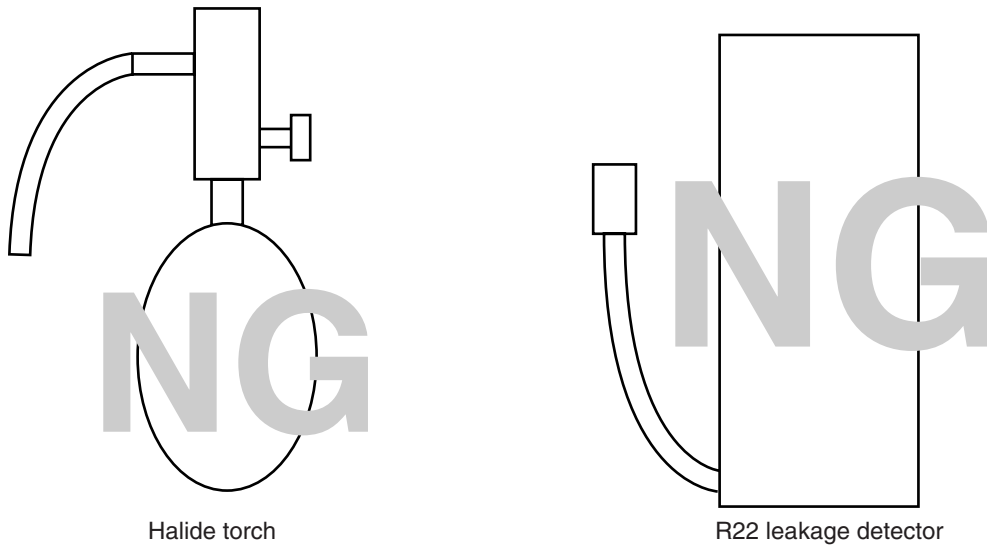

Items to be strictly observed:

1. Pressurize the equipment with nitrogen up to the design pressure and then judge the equipment's airtightness, taking temperature variations into account.
2. When investigating leakage locations using a refrigerant, be sure to use R407C.
3. Ensure that R407C is in a liquid state when charging.

Reasons:

1. Use of oxygen as the pressurized gas may cause an explosion.
2. Charging with R407C gas will lead the composition of the remaining refrigerant in the cylinder to change and this refrigerant can then not be used.

Note:

- A leakage detector for R407C is sold commercially and it should be purchased.

[6] Vacuuming

1. Vacuum pump with check valve
A vacuum pump with a check valve is required to prevent the vacuum pump oil from flowing back into the refrigerant circuit when the vacuum pump power is turned off (power failure).
It is also possible to attach a check valve to the actual vacuum pump afterwards.
2. Standard degree of vacuum for the vacuum pump
Use a pump which reaches 0.5 Torr (500 MICRON) or below after 5 minutes of operation.
In addition, be sure to use a vacuum pump that has been properly maintained and oiled using the specified oil. If the vacuum pump is not properly maintained, the degree of vacuum may be too low.
3. Required accuracy of the vacuum gauge
Use a vacuum gauge that can measure up to 5 Torr. Do not use a general gauge manifold since it cannot measure a vacuum of 5 Torr.
4. Evacuating time
 - Evacuate the equipment for 1 hour after -755 mmHg (5 Torr) has been reached.
 - After evacuating, leave the equipment for 1 hour and make sure the that vacuum is not lost.
5. Operating procedure when the vacuum pump is stopped
In order to prevent a backflow of the vacuum pump oil, open the relief valve on the vacuum pump side or loosen the charge hose to drawn in air before stopping operation.
The same operating procedure should be used when using a vacuum pump with a check valve.

[7] Charging of Refrigerant

R407C must be in a liquid state when charging, because it is a non-azeotropic refrigerant.

For a cylinder with a syphon attached

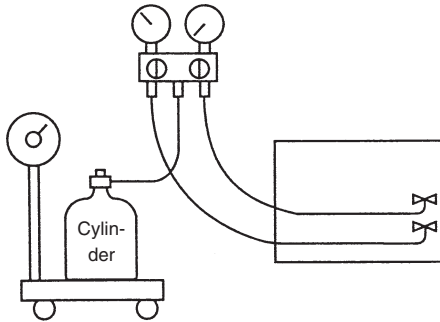

For a cylinder without a syphon attached

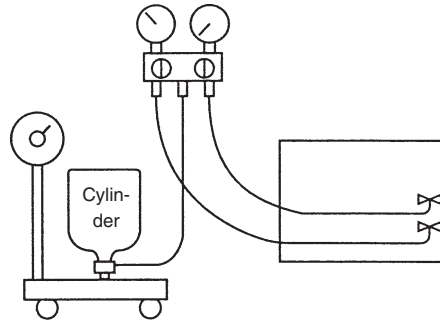

Cylinder color identification R407C-Gray
R410A-Pink

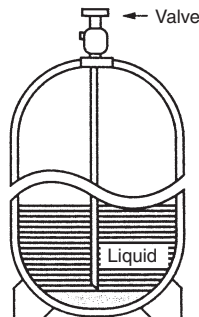

Charged with liquid refrigerant

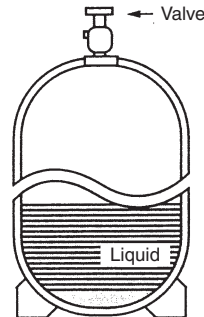

Reasons:

1. R407C is a mixture of 3 refrigerants, each with a different evaporation temperature. Therefore, if the equipment is charged with R407C gas, then the refrigerant whose evaporation temperature is closest to the outside temperature is charged first while the rest of refrigerants remain in the cylinder.

Note:

- In the case of a cylinder with a syphon, liquid R407C is charged without turning the cylinder up side down. Check the type of cylinder before charging.

2 PART NAMES AND FUNCTIONS

Indoor unit

- Air inlet : Sucks the ambient air in.
- Filter : The filter built into the unit as standard is a simple filter to remove visible dust and dirt. If air purification is one of the conditions required for use, consult with your dealer.
- Air outlet : Blows the air back out into the room.

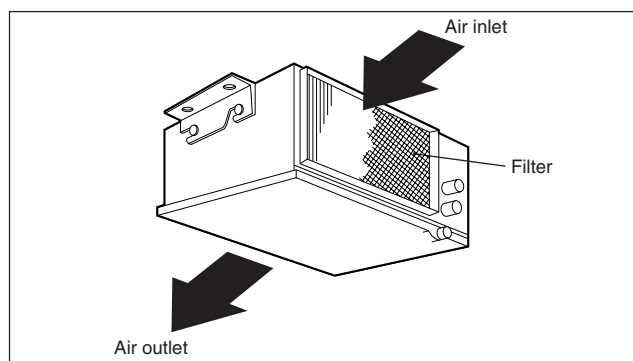

Remote controller (PAR-20MAA)

- Once the controls are set, the same operation mode can be repeated by simply pressing the ON/OFF button.

Operation buttons

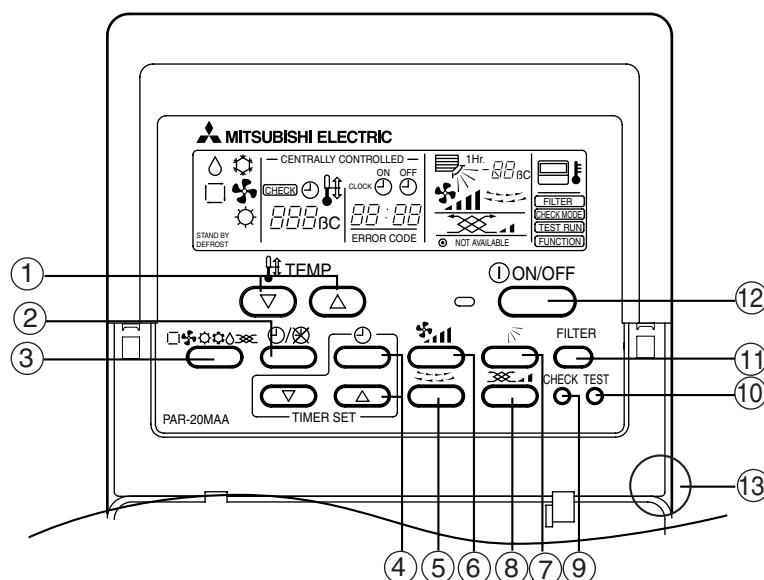

- ① [Room temperature adjustment] Button
- ② [Timer/continuous] Button
- ③ [Selecting operation] Button
- ④ Time selection] Button
[Time-setting] Button
- ⑤ [Louver] Button (This button does not operate in this model)
- ⑥ [Fan speed adjustment] Button
- ⑦ [Up/down airflow direction] Button (This button does not operate in this model)
- ⑧ [Ventilation] Button
- ⑨ [Checking/built-in] Button
- ⑩ [Test run] Button
- ⑪ [Filter] Button (This button does not operate in this model)
- ⑫ [ON/OFF] Button
- ⑬ Position of built-in room temperature

- Never expose the remote controller to direct sunlight. Doing so can result in the erroneous measurement of room temperature.
- Never place any obstacle around the lower right-hand section of the remote controller. Doing so can result in the erroneous measurement of room temperature.

Display

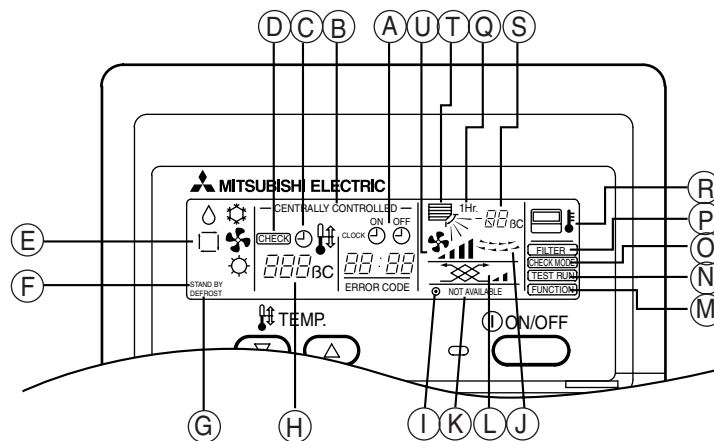

- | | |
|---|-----------------------------|
| (A) Current time/Timer | (K) Not available function |
| (C) Centralized control | (L) Ventilation |
| (D) Abnormality control | (M) Function setting mode |
| (E) Operation mode: COOL, DRY, AUTO, FAN, HEAT | (N) Test run mode |
| (F) Preparing for Heating mode | (O) Error check mode |
| (G) Defrost mode | (P) Filter sign |
| (H) Set temperature | (Q) Set effective for 1 hr. |
| (I) Power ON | (R) Sensor position |
| (J) Louver | (S) Room temperature |
| | (T) Airflow |
| | (U) Fan speed |

Caution:

- Only the Power display lights when the unit is stopped and power supplied to the unit.
- When power is turned ON for the first time the (CENTRAL CTRL) display appears to go off momentarily but this is not a malfunction.
- When the central control remote control unit, which is sold separately, is used the ON-OFF button, operation switch button and TEMP. adjustment button do not operate.
- "NOT AVAILABLE" is displayed when the Airflow direction button or Louver button are pressed. This indicates that this room unit is not equipped with the fan direction adjustment function and the louver function.
- When power is turned ON for the first time, it is normal that "H0" is displayed on the room temperature indication (For max. 2 minutes). Please wait until this "H0" indication disappear then start the operation.

3 SPECIFICATIONS

Specifications of air-source heat pump type packaged air conditioner (Ceiling concealed type indoor unit)						
Model name	PEH-P8MYA		Quantity		Symbol	
			Cooling	Heating		
Capacity		kcal/h	18,000	20,400		
		kW	20.9	23.7		
Air condition	Indoor side	Dry bulb temperature/wet bulb temperature	27 °C/19 °C	20 °C/–		
	Outdoor side	Dry bulb temperature/wet bulb temperature	35 °C/24 °C	7 °C/6 °C		
Power source			3N~ 380/400/415V 50Hz			
Electrical characteristics	Power consumption		kW	0.65/0.65/0.65	0.65/0.65/0.65	
	Operating current		A	1.12/1.12/1.12	1.12/1.12/1.12	
Remote controller temperature setting range			°C	19 ~ 30	17 ~ 28	
Airflow direction control			–			
Fan	Type × Quantity		Sirrocco fan × 2			
	Airflow rate		m ³ /min	60		
	External static pressure		Pa	50/150		
	Motor output		kW	0.75		
External finish			Galvanizing			
External dimension	Unit (H × W × D)		mm	428 × 1380 × 650		
	Panel (H × W × D)		mm	–		
Heat exchanger type			Cross fin			
Air filter			Saran net			
Insulation material			Polyethylene foam			
Refrigerant piping dimension Liquid/Gas		φmm	12.7/25.4			
Drain piping dimension		φmm	25.4 (RC1)			
Noise level		dB (A)	49 (at 50 Pa)			
Net weight		kg	70			
External wiring	Minimum wire thickness			1.6 mm		
	Circuit breaker			15 A		
Composing parts	Operation control device (provided)		Remote controller: PAR-20MAA			
	Decoration panel (Option)		–			
Other mountable major options			–			
Accessories			Installation manual, Operation manual, Remote controller			
Special note, Non-standard specifications, etc.			–			
Notes:	<ol style="list-style-type: none"> The cooling and heating capacities are the maximum capacities that were obtained by operating in the above air conditions and with a refrigerant pipe of about 7.5 m. The actual capacity characteristics vary with the combination of indoor and outdoor units. See the technical information. The operating noise is the data that was obtained by measuring it 1.5 m from the unit's bottom in an anechoic room. (Noise meter A-scale value) The figure of Electrical characteristic, Airflow rate, Noise level, indicates, at 50 Pa setting. 					

**Specifications of air-source heat pump type packaged air conditioner
(Ceiling concealed type indoor unit)**

Model name	PEH-P10MYA	Quantity		Symbol	
------------	-------------------	----------	--	--------	--

			Cooling	Heating	
Capacity		kcal/h	22,400	26,200	
		kW	26.0	30.5	
Air condition	Indoor side	Dry bulb temperature/wet bulb temperature	27 °C/19 °C	20 °C/-	
	Outdoor side	Dry bulb temperature/wet bulb temperature	35 °C/24 °C	7 °C/ 6 °C	
Power source			3N~ 380/400/415V 50 Hz		
Electrical characteristics	Power consumption		kW	0.94/0.94/0.94	0.94/0.94/0.94
	Operating current		A	1.64/1.64/1.64	1.64/1.64/1.64
Remote controller temperature setting range			°C	19 ~ 30	17 ~ 28
Airflow direction control			Vertical	-	
Fan	Type × Quantity		Sirrocco fan × 2		
	Airflow rate		m ³ /min	80	
	External static pressure		Pa	50/150	
	Motor output		kW	1.23	
External finish			Galvanizing		
External dimension	Unit (H × W × D)		mm	428 × 1,580 × 650	
	Panel (H × W × D)		mm	-	
Heat exchanger type			Cross fin		
Air filter			Saran net		
Insulation material			Polyethylene foam		
Refrigerant piping size		Liquid/Gas	φmm	12.7/28.58	
Drain piping size			φmm	25.4 (RC1)	
Noise level			dB (A)	53 (at 50 Pa)	
Net weight			kg	80	
External wiring	Minimum wire thickness		1.6 mm		
	Circuit breaker		15 A		
Composing parts	Operation control device (provided)		Remote controller: PAR-20MAA		
	Decoration panel (Option)		-		
Other mountable major options			-		
Accessories			Installation manual, Operation manual, Remote controller		
Special note, Non-standard specifications, etc.			-		
Notes:	<ol style="list-style-type: none"> 1. The cooling and heating capacities are the maximum capacities that were obtained by operating in the above air conditions and with a refrigerant pipe of about 7.5 m. 2. The actual capacity characteristics vary with the combination of indoor and outdoor units. See the technical information. 3. The operating noise is the data that was obtained by measuring it 1.5 m from the unit's bottom in an anechoic room. (Noise meter A-scale value) 4. The figure of Electrical characteristic, Airflow rate, Noise level, indicates, at 50 Pa setting. 				

**Specifications of air-source heat pump type packaged air conditioner
(Ceiling concealed type indoor unit)**

Model name	PEH-P16MYA		Quantity		Symbol	
Capacity			kcal/h	36,000	Cooling	40,800
			kW	41.8		47.4
Air condition	Indoor side	Dry bulb temperature/wet bulb temperature		27 °C/19 °C		20 °C/–
	Outdoor side	Dry bulb temperature/wet bulb temperature		35 °C/24 °C		7 °C/6 °C
Power source				3N~ 380/415V 50Hz		
Electrical characteristics		Power consumption	kW	2.3/2.3		2.3/2.3
		Operating current	A	4.5/4.1		4.5/4.1
Remote controller temperature setting range			°C	19 ~ 30		17 ~ 28
Airflow direction control				–		
Fan	Type × Quantity			Sirocco fan × 2		
	Airflow rate		m ³ /min	140		
	External static pressure		Pa	150		
	Motor output		kW	1.5		
External finish				Galvanizing		
External dimension		Unit (H × W × D)	mm	706 × 1,690 × 865		
		Panel (H × W × D)	mm	–		
Heat exchanger type				Cross fin		
Air filter				Saran net		
Insulation material				Polyethylene foam		
Refrigerant piping dimension Liquid/Gas			φmm	(12.7/25.4) × 2		
Drain piping dimension			φmm	25.4 (RC1)		
Noise level			dB (A)	55		
Net weight			kg	180		
Control capacity			%	0–50–100		
External wiring		Minimum wire thickness		1.6 mm		
		Circuit breaker		15 A		
Composing parts		Operation control device (provided)		Remote controller: PAR-20MAA		
		Decoration panel (Option)		–		
Other mountable major options				–		
Accessories				Installation manual, Operation manual, Remote controller		
Special note, Non-standard specifications, etc.				–		
Notes:	<ol style="list-style-type: none"> The cooling and heating capacities are the maximum capacities that were obtained by operating in the above air conditions and with a refrigerant pipe of about 7.5 m. The actual capacity characteristics vary with the combination of indoor and outdoor units. See the technical information. The operating noise is the data that was obtained by measuring it 1.5 m from the unit's bottom in an anechoic room. (Noise meter A-scale value) 					

**Specifications of air-source heat pump type packaged air conditioner
(Ceiling concealed type indoor unit)**

Model name	PEH-P20MYA	Quantity		Symbol	
------------	-------------------	----------	--	--------	--

			Cooling	Heating
Capacity		kcal/h	44,800	52,400
		kW	52.0	61.0
Air condition	Indoor side	Dry bulb temperature/wet bulb temperature	27 °C/19 °C	20 °C/–
	Outdoor side	Dry bulb temperature/wet bulb temperature	35 °C/24 °C	7 °C/ 6 °C
Power source			3N~ 380/415V 50 Hz	
Electrical characteristics	Power consumption		kW	2.5/2.5
	Operating current		A	5.1/4.7
Remote controller temperature setting range			°C	19 ~ 30
Airflow direction control			Vertical	–
Fan	Type × Quantity		Sirrocco fan × 2	
	Airflow rate		m ³ /min	170
	External static pressure		Pa	150
	Motor output		kW	2.0
External finish			Galvanizing	
External dimension	Unit (H × W × D)		mm	706 × 1,993 × 865
	Panel (H × W × D)		mm	–
Heat exchanger type			Cross fin	
Air filter			Saran net	
Insulation material			Polyethylene foam	
Refrigerant piping size		Liquid/Gas	φmm	(12.7/28.58) × 2
Drain piping size			φmm	25.4 (RC1)
Noise level			dB (A)	60
Net weight			kg	212
Control capacity			%	0–50–100
External wiring	Minimum wire thickness		1.6 mm	
	Circuit breaker		15 A	
Composing parts	Operation control device (provided)		Remote controller: PAR-20MAA	
	Decoration panel (Option)		–	
Other mountable major options			–	
Accessories			Installation manual, Operation manual, Remote controller	
Special note, Non-standard specifications, etc.			–	
Notes:	<ol style="list-style-type: none"> The cooling and heating capacities are the maximum capacities that were obtained by operating in the above air conditions and with a refrigerant pipe of about 7.5 m. The actual capacity characteristics vary with the combination of indoor and outdoor units. See the technical information. The operating noise is the data that was obtained by measuring it 1.5 m from the unit's bottom in an anechoic room. (Noise meter A-scale value) 			

4 PART NAMES AND FUNCTIONS

(1) Indoor Unit

• Models PEH-P8MYA

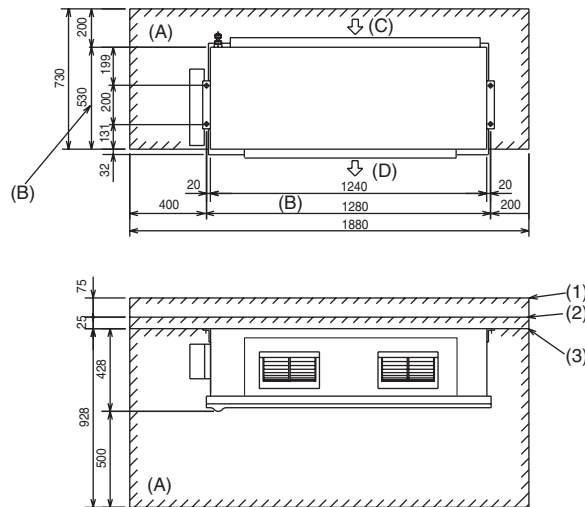

- (1) When connecting air inlet
- (2) When installing the suspension fixtures prior to installation of the indoor unit without inlet duct
- (3) When hanging the indoor unit directly without inlet duct

- (A) Service space
- (B) Suspension bolt pitch
- (C) Air inlet
- (D) Air outlet

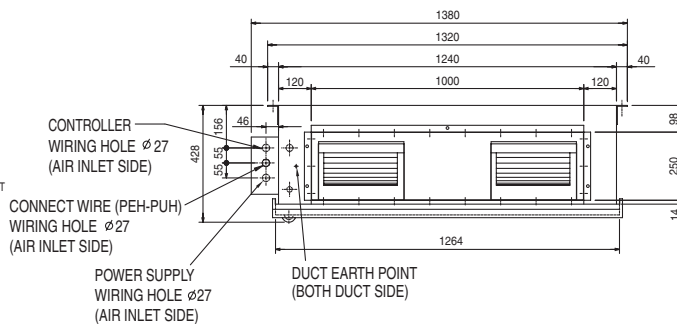
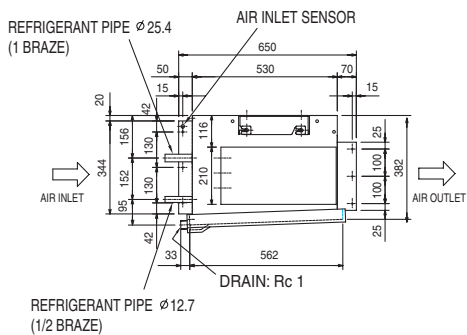
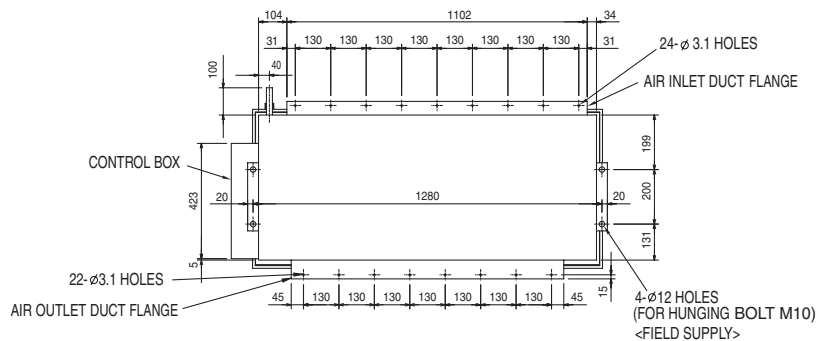

Note: When connecting duct to the inlet side, remove the air filter attached to the unit body, and mount an air filter onto the inlet duct side separately

• Models PEH-P10MYA

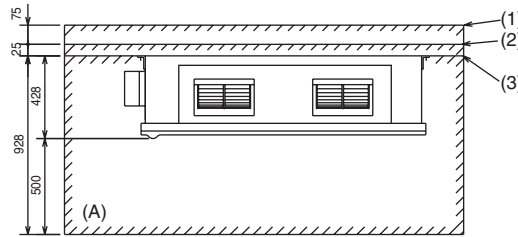
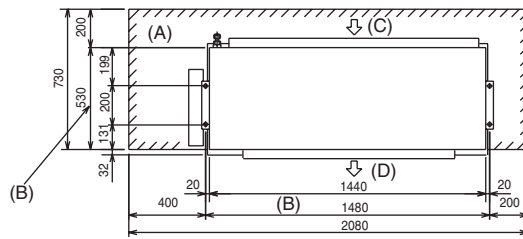

- (1) When connecting air inlet
- (2) When installing the suspension fixtures prior to installation of the indoor unit without inlet duct
- (3) When hanging the indoor unit directly without inlet duct

- (A) Service space
- (B) Suspension bolt pitch
- (C) Air inlet
- (D) Air outlet

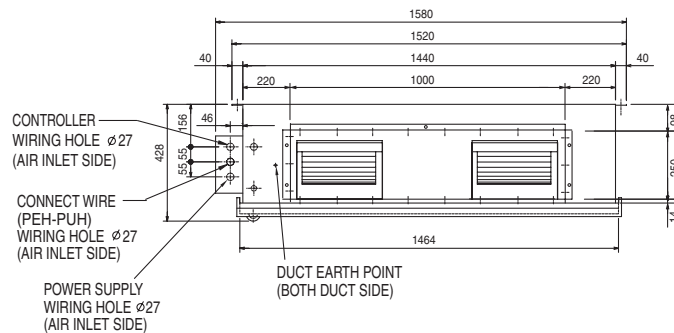
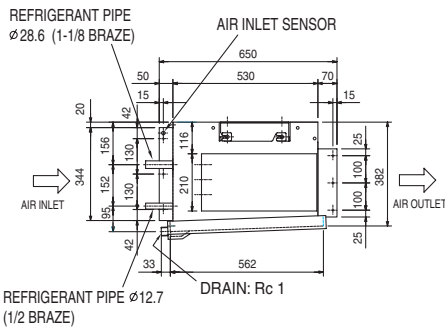
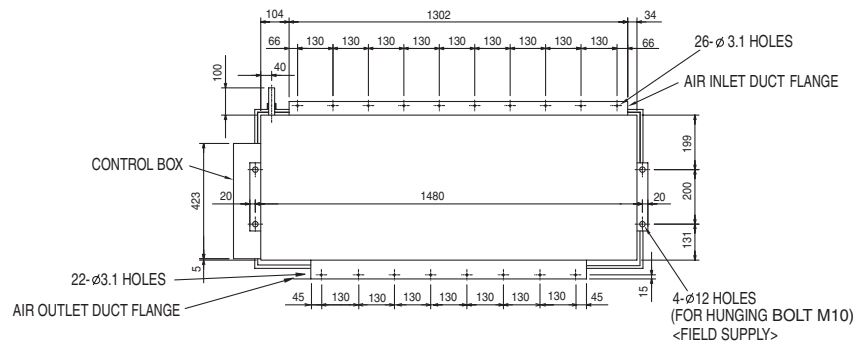

Note: When connecting duct to the inlet side, remove the air filter attached to the unit body, and mount an air filter onto the inlet duct side separately

• Models PEH-P16MYA

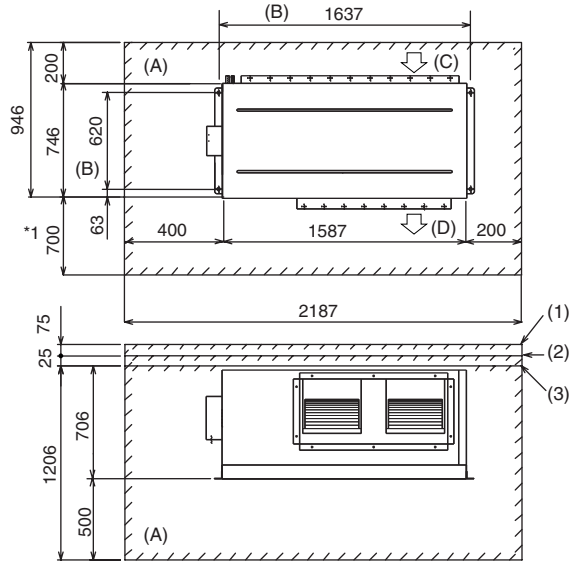

- (1) When connecting air inlet
- (2) When installing the suspension fixtures prior to installation of the indoor unit without inlet duct
- (3) When hanging the indoor unit directly without inlet duct
- (A) Service space
- (B) Suspension bolt pitch
- (C) Air inlet
- (D) Air outlet

*1 When there is not 500mm of service space on top of the unit, there must be 700mm of service space at the air outlet side.

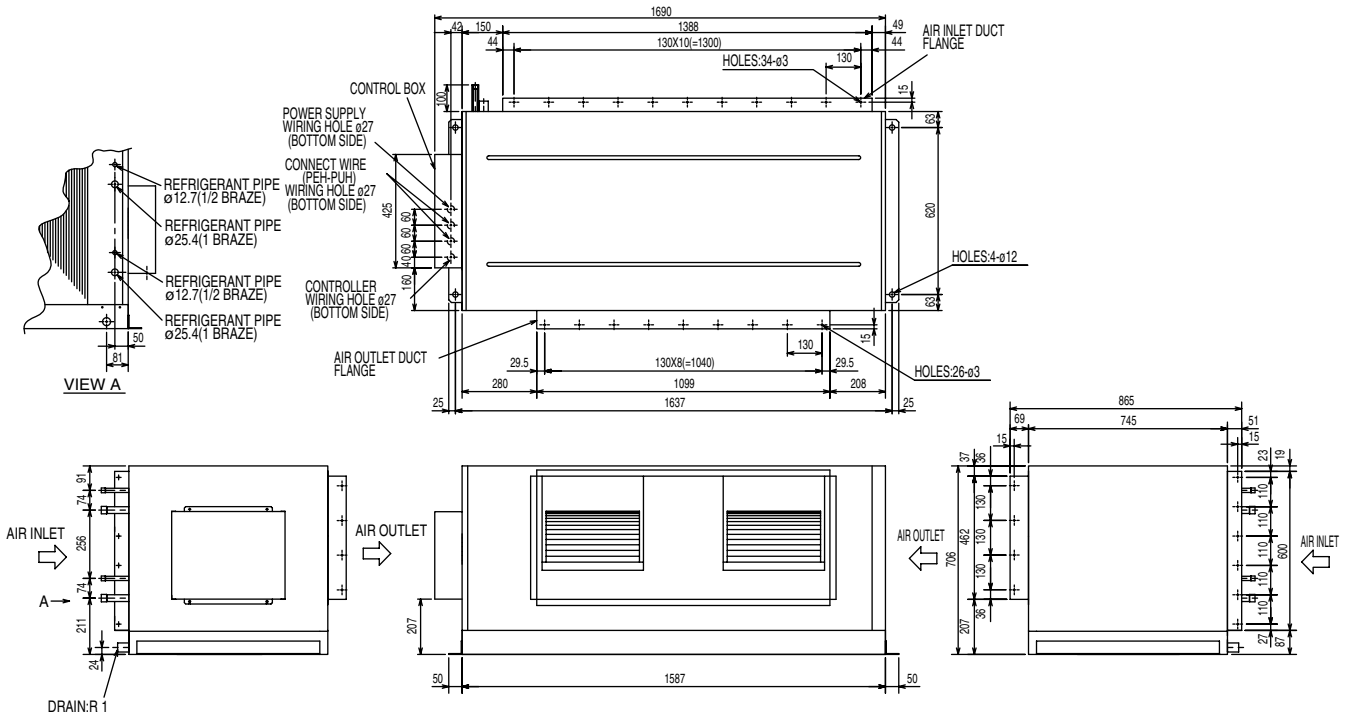

• Models PEH-P20MYA

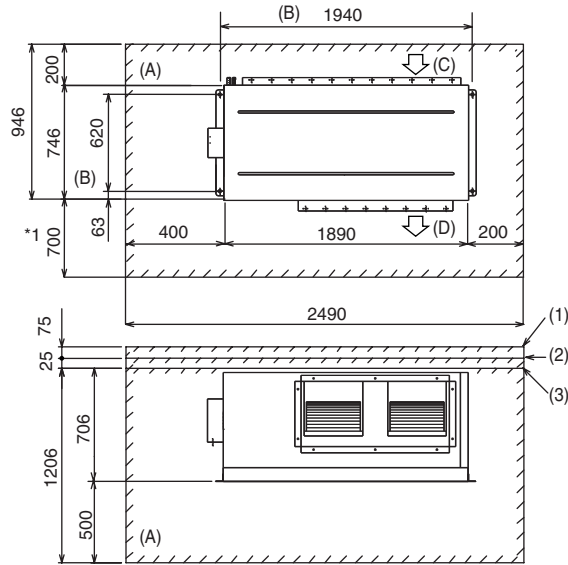

- (1) When connecting air inlet
- (2) When installing the suspension fixtures prior to installation of the indoor unit without inlet duct
- (3) When hanging the indoor unit directly without inlet duct
- (A) Service space
- (B) Suspension bolt pitch
- (C) Air inlet
- (D) Air outlet

*1 When there is not 500mm of service space on top of the unit, there must be 700mm of service space at the air outlet side.

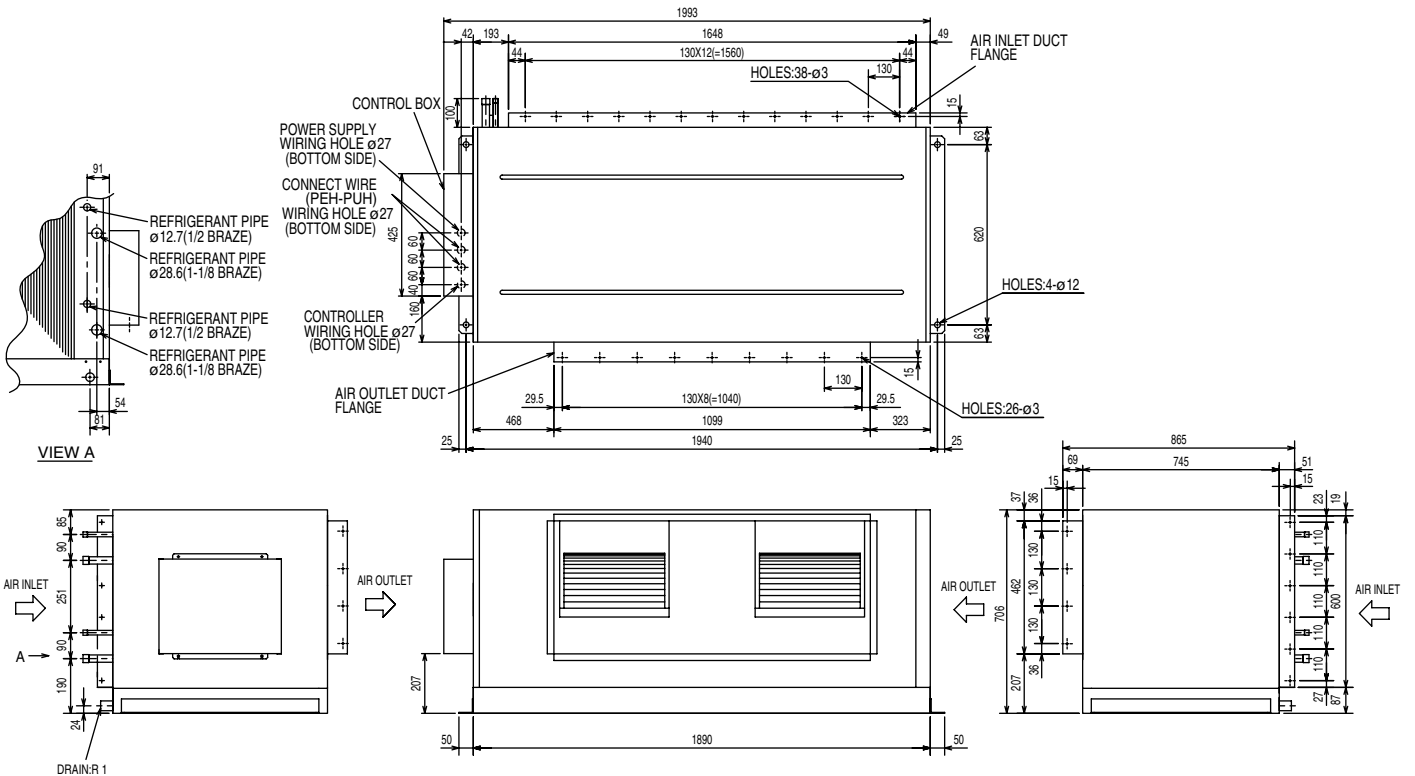

(2) Remote Controller

- Models PAR-20MAA

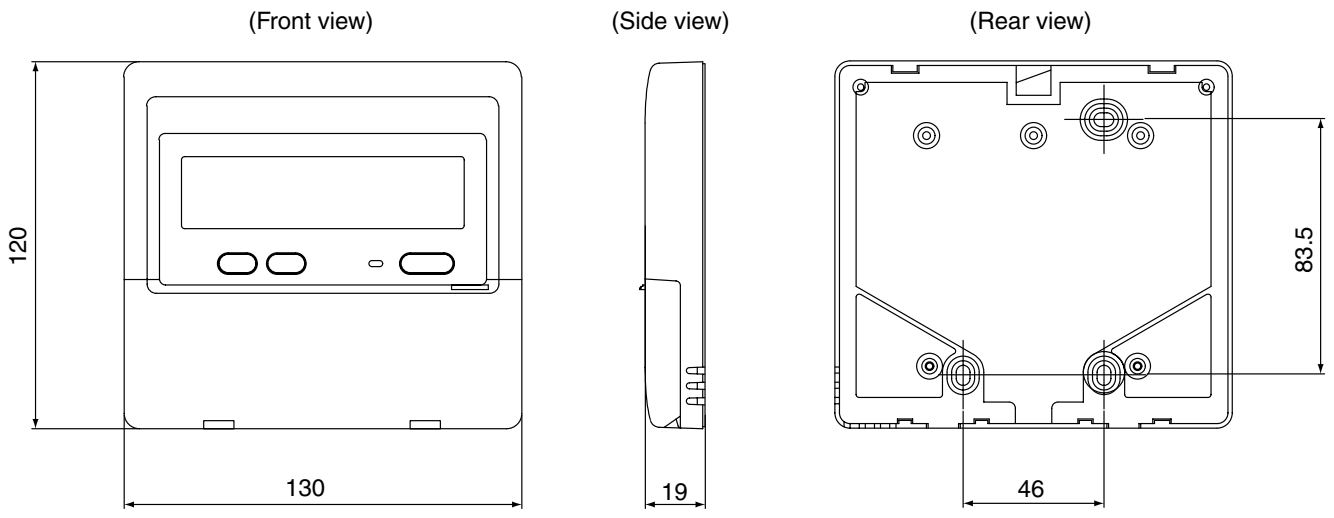

5 ELECTRICAL WIRING DIAGRAM

(1) Indoor Unit

• Models PEH-P8MYA/P10MYA

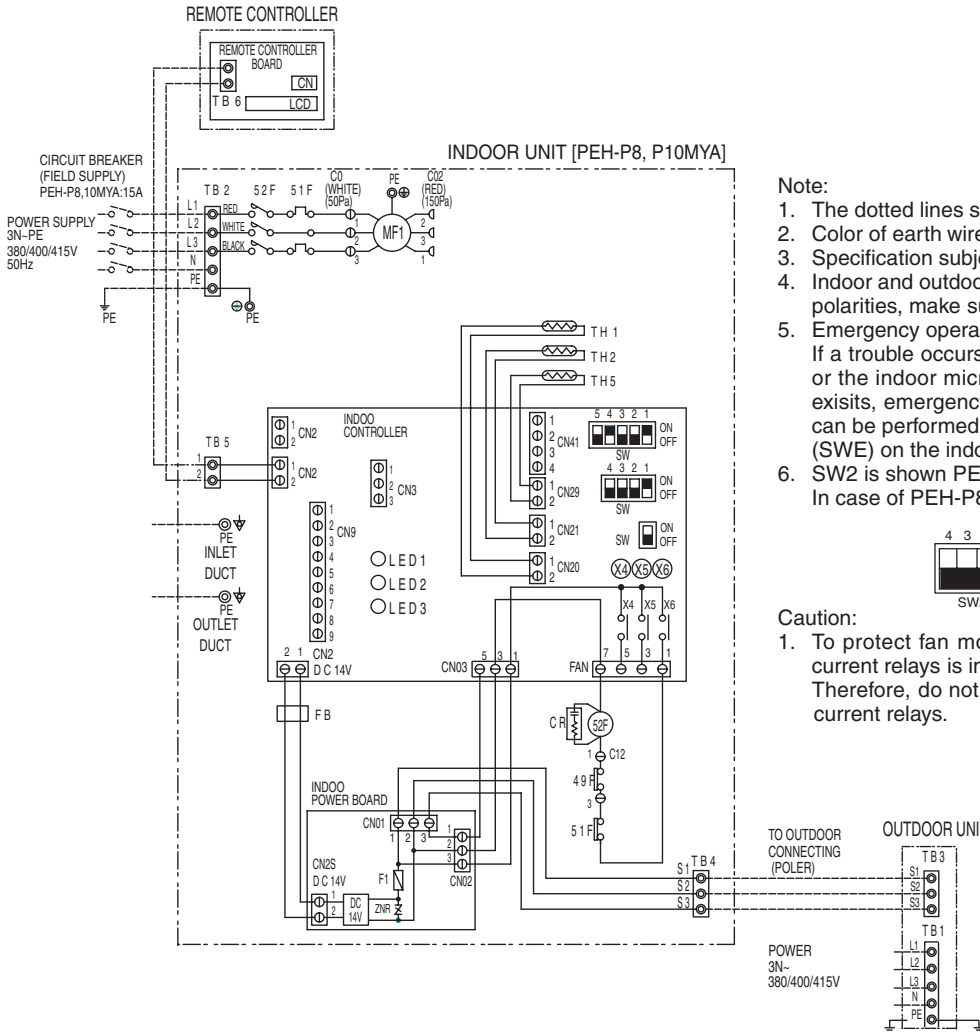

Note:

1. The dotted lines show field wiring.
2. Color of earth wire is yellow and green twisting.
3. Specification subject to change without notice.
4. Indoor and outdoor connecting wires are made with polarities, make sure matching wiring and terminal.
5. Emergency operation
If a trouble occurs with either the remote controller or the indoor microcomputer and no other trouble exists, emergency operation for cooling or heating can be performed by changing the setting of switch (SWE) on the indoor controller board.
6. SW2 is shown PEH-P10MYA setting.
In case of PEH-P8MYA setting is shown as below.

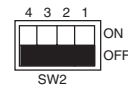

Caution:

1. To protect fan motor from abnormal current, over current relays is installed.
Therefore, do not change factory set value of over current relays.

INDOOR UNIT

SYMBOL	NAME	
MF1	FAN MOTOR (INDOOR)	
51F	OVER CURRENT RELAY (INDOOR FAN MOTOR)	
52F	CONTACTOR (INDOOR FAN MOTOR)	
49F	INTERNAL THERMOSTAT (INDOOR FAN MOTOR)	
TB2, 4, 5	TERMINAL BLOCK	
TH1	THERMISTOR	ROOM TEMP. (0°C/15kΩ, 25°C/5.4kΩ)
TH2		PIPE TEMP. (0°C/15kΩ, 25°C/5.4kΩ)
TH5		COND./EVA. TEMP. (0°C/15kΩ, 25°C/5.4kΩ)
F1	FUSE (4A 250VAC CLASS T)	
ZNR	VARISTOR	
X4-6	AUXILIARY RELAY (INDOOR CONTROLLER BOARD)	
SW1	SWITCH (MODEL SELECTION)	
SW2	SWITCH (CAPACITY CORD)	
SWE	SWITCH (EMERGENCY OPERATION)	
LED1	LED (POWER SUPPLY : INDOOR CONTROLLER BOARD)	
LED2	LED (POWER SUPPLY : REMOTE CONTROLLER)	
LED3	LED (TRANSMISSION : INDOOR-OUTDOOR)	
CR	SURGE KILLER	
CN03, CN21, 2D CN20-22, 29, 32 CN41, 90, FAN	CONNECTOR (INDOOR CONTROLLER BOARD)	
CN01, 02, 2S	CONNECTOR (INDOOR POWER BOARD)	
C01, 02, 12	CONNECTOR (FAN MOTOR)	
FB	FERRITE CORE	

OUTDOOR UNIT

SYMBOL	NAME
TB3	TERMINAL BLOCK

REMOTE CONTROLLER

SYMBOL	NAME
TB6	TERMINAL BLOCK

• Models PEH-P16,20MYA

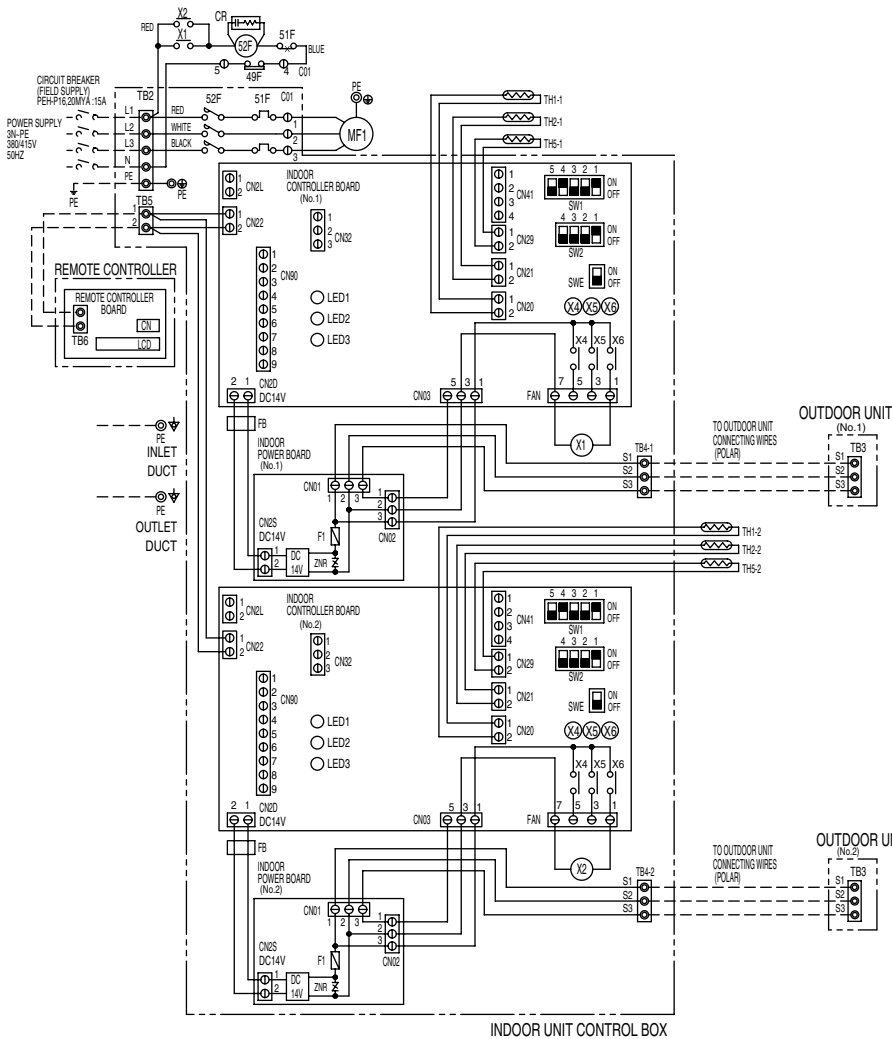

Note:

1. The dotted lines show field wiring.
2. Color of earth wire is yellow and green twisting.
3. Specification subject to change without notice.
4. Indoor and outdoor connecting wires are made with polarities, make sure matching wiring and terminal.
5. Emergency operation
If a trouble occurs with either the remote controller or the indoor micro-computer and no other trouble exists, emergency operation for cooling or heating can be performed by changing the setting of switch (SWE) on the indoor controller board.
6. SW2 is shown PEH-P20MYA setting. (2 places)
In case of PEH-P16MYA setting is shown as below.



Caution:

1. To protect fan motor from abnormal current, over current relays is installed. Therefore, do not change factory set value of over current relays.

INDOOR UNIT

SYMBOL	NAME
MF1	FAN MOTOR (INDOOR)
51F	OVER CURRENT RELAY (INDOOR FAN MOTOR)
52F	CONTACTOR (INDOOR FAN MOTOR)
49F	INTERNAL THERMOSTAT (INDOOR FAN MOTOR)
TB2,4-1,4-2,5	TERMINAL BLOCK
TH1-1,1-2	ROOM TEMP (0°C/15kΩ, 25°C/5.4kΩ)
TH2-1-2-2	PIPE TEMP (0°C/15kΩ, 25°C/5.4kΩ)
TH5-1,5-2	COND./EVA. TEMP (0°C/15kΩ, 25°C/5.4kΩ)
F1	FUSE(4A 250VAC CLASS T)
ZNR	VARISTOR
X1,2	AUXILIARY RELAY
X4-6	AUXILIARY RELAY(INDOOR CONTROLLER BOARD)
SW1	SWITCH(MODEL SELECTION)
SW2	SWITCH(CAPACITY CORD)
SWE	SWITCH(EMERGENCY OPERATION)
LED1	LED (POWER SUPPLY :INDOOR CONTROLLER BOARD)
LED2	LED (POWER SUPPLY :REMOTE CONTROLLER)
LED3	LED (TRANSMISSION :INDOOR-OUTDOOR)
CR CN03,CN2L,2D CN20-22,29,32 CN41,90,FAN	SURGE KILLER CONNECTOR(INDOOR CONTROLLER BOARD)
CN01,02,2S	CONNECTOR(INDOOR POWER BOARD)
FB	FERRITE CORE

OUTDOOR UNIT

SYMBOL	NAME
TB3	TERMINAL BLOCK

REMOTE CONTROLLER

SYMBOL	NAME
TB6	TERMINAL BLOCK

6 TECHNICAL DATA TO MEET LVD

[1] Capacity/Input Ratio against Changes in Room Airflow Rate

• Models PEH-P8MYA

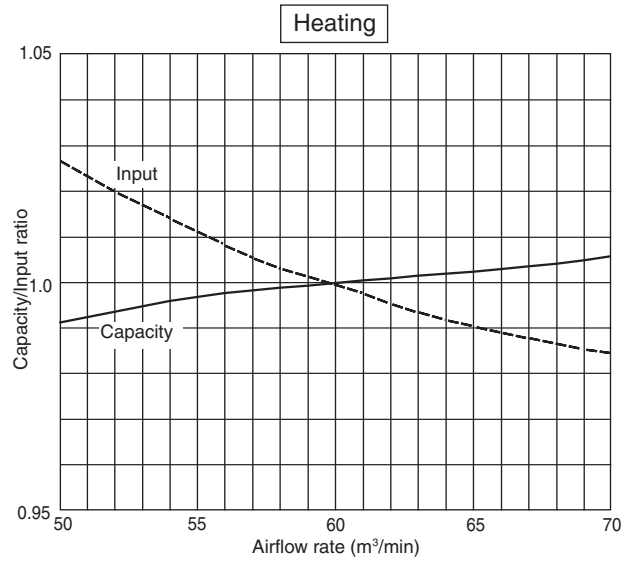
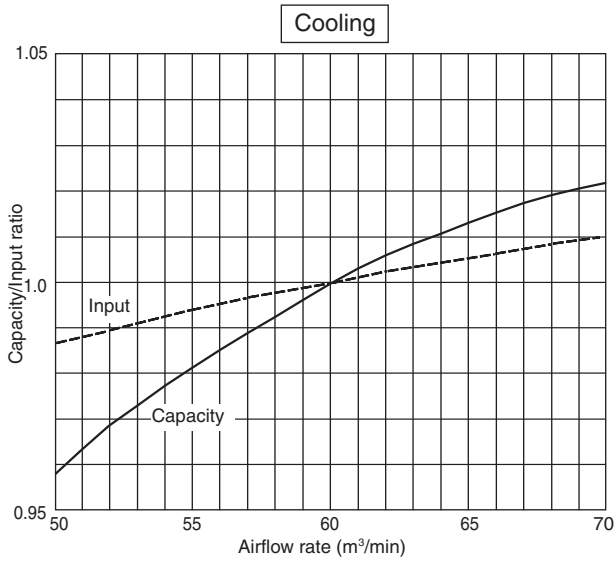

• Models PEH-P10MYA

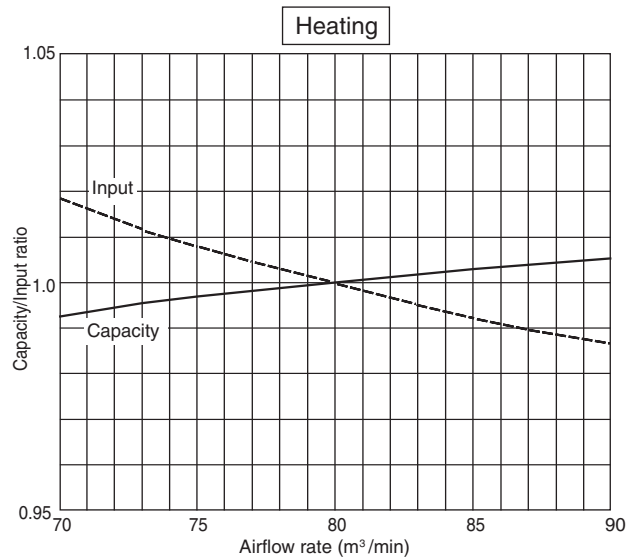
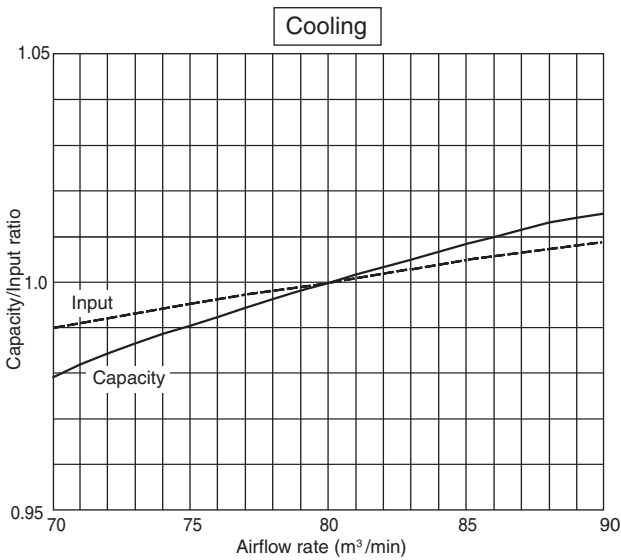

• Models PEH-P16MYA

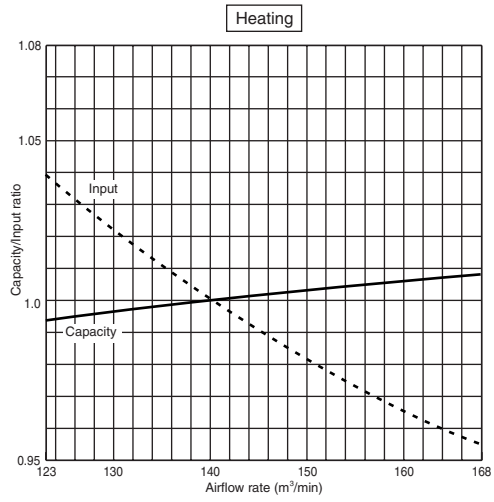
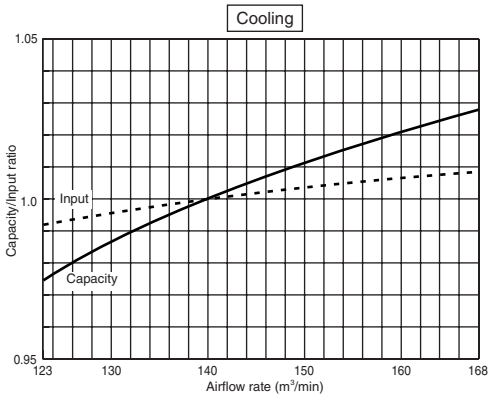

• Models PEH-P20MYA

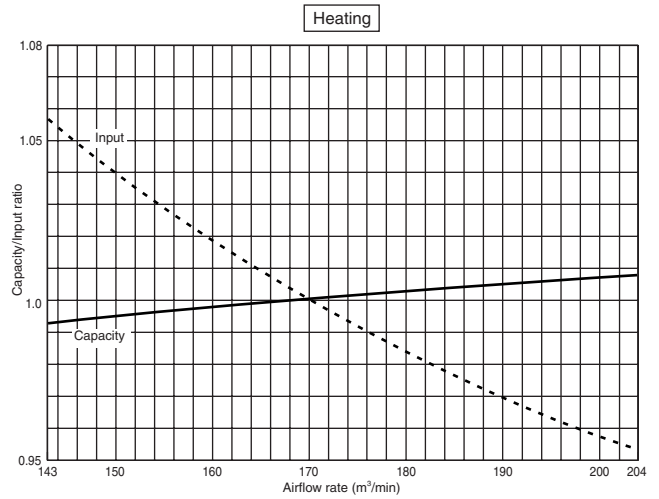
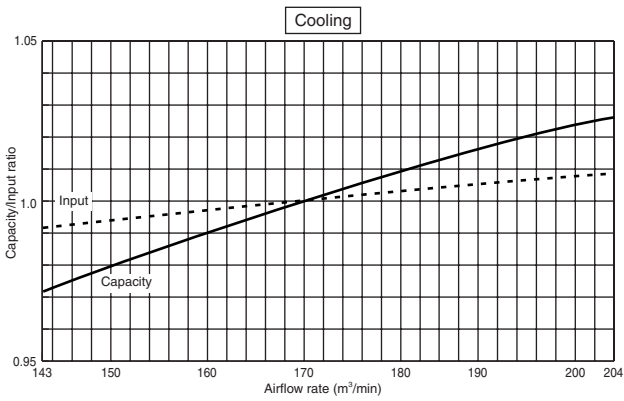

[2] Bypass Factor Curves

PEH-P8MYA

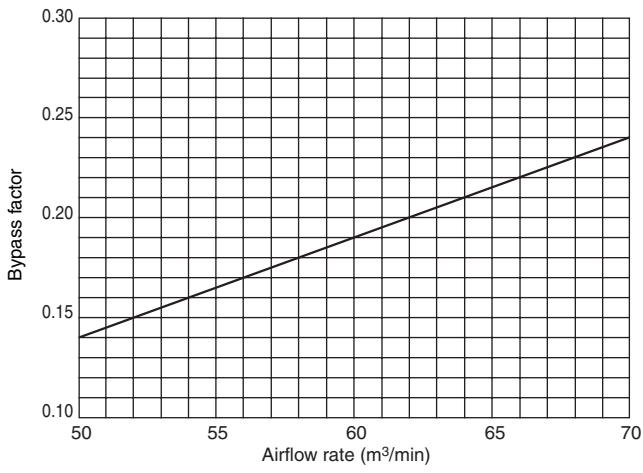

PEH-P10MYA

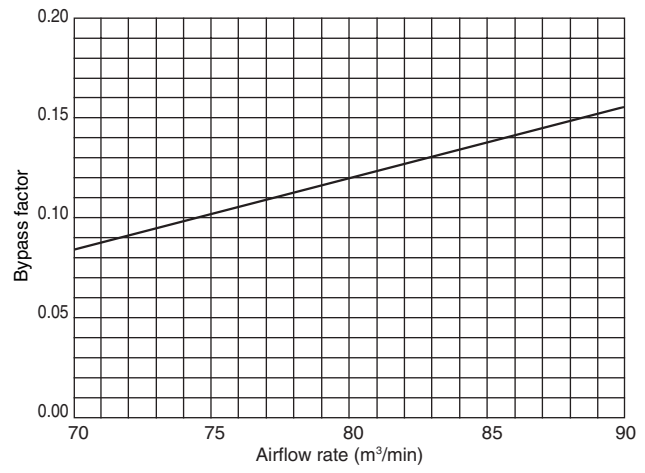

PEH-P16MYA

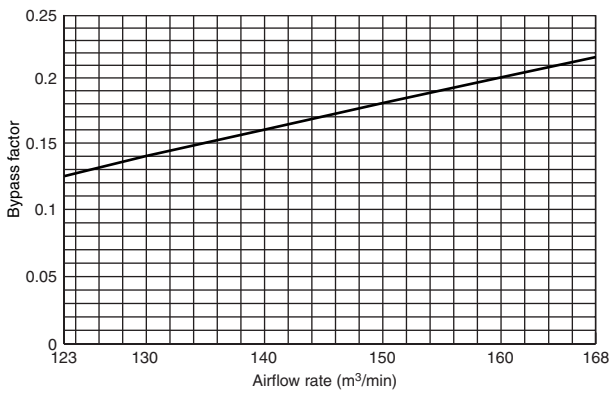

PEH-P20MYA

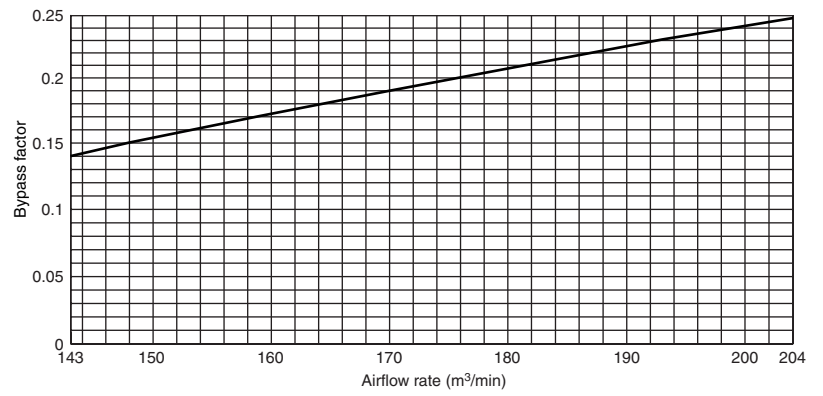

[3] Cooling Sensible Heating Capacity Table

(1) PEH-P8MYA (Airflow rate 60m³/min)

Outdoor temp. (°C)	Indoor inlet air temperature (DB/WB°C)									
	23/16		25/18		27/19		28/20		30/22	
	CA	SHC	CA	SHC	CA	SHC	CA	SHC	CA	SHC
20	18100	13700	19300	13500	20000	14400	20800	14400	21900	14200
25	17500	13400	18700	13300	19500	13700	20300	14200	21500	13900
30	16900	13100	18100	13000	18900	13500	19700	14000	20900	13700
35	16200	12800	17400	12700	18000	13100	19000	13700	20200	13500
40	15300	12500	16600	12400	17400	13000	18200	13500	19500	13300
43	14800	12400	16000	12300	16900	12900	17700	13400	19000	13200

(2) PEH-P10MYA (Airflow rate 80m³/min)

Outdoor temp. (°C)	Indoor inlet air temperature (DB/WB°C)									
	23/16		25/18		27/19		28/20		30/22	
	CA	SHC	CA	SHC	CA	SHC	CA	SHC	CA	SHC
20	22500	18100	24000	17900	24900	18500	25800	19200	27300	18800
25	21800	17800	23300	17600	24300	18300	25200	18900	26700	18600
30	21000	17500	22500	17300	23500	17900	24500	18600	26000	18300
35	20100	17100	21600	16800	22400	17400	23600	18300	25200	18100
40	19100	16800	20600	16600	21600	17400	22700	18100	24200	17900
43	18400	16600	20000	16500	21000	17300	22000	18000	23600	17800

(3) PEH-P16MYA (Airflow rate 140m³/min)

Outdoor temp. (°C)	Indoor inlet air temperature (DB/WB°C)									
	23/16		25/18		27/19		28/20		30/22	
	CA	SHC	CA	SHC	CA	SHC	CA	SHC	CA	SHC
20	36200	29200	38600	28900	40000	31000	41600	30900	43800	30400
25	35000	28600	37400	28400	39000	30500	40600	30500	43000	30100
30	33800	28100	36200	27900	37800	30100	39400	30100	41800	29700
35	32400	27400	34800	27300	36000	29300	38000	29500	40400	29200
40	30600	26600	33200	26700	34800	28800	36400	28900	39000	28700
43	29600	26200	32000	26200	33800	28400	35400	28500	38000	28300

(4) PEH-P20MYA (Airflow rate 170m³/min)

Outdoor temp. (°C)	Indoor inlet air temperature (DB/WB°C)									
	23/16		25/18		27/19		28/20		30/22	
	CA	SHC	CA	SHC	CA	SHC	CA	SHC	CA	SHC
20	45000	32900	48000	32700	49800	34600	51600	34600	54600	34100
25	43600	32200	46600	32000	48600	34100	50400	34100	53400	33600
30	42000	31400	45000	31300	47000	33400	49000	33500	52000	33000
35	40200	30600	43200	30500	44800	32500	47200	32700	50400	32400
40	38200	29600	41200	29600	43200	31800	45400	32000	48400	31600
43	36800	29000	40000	29100	42000	31300	44000	31400	47200	31200

[4] Airflow Characteristic Curves

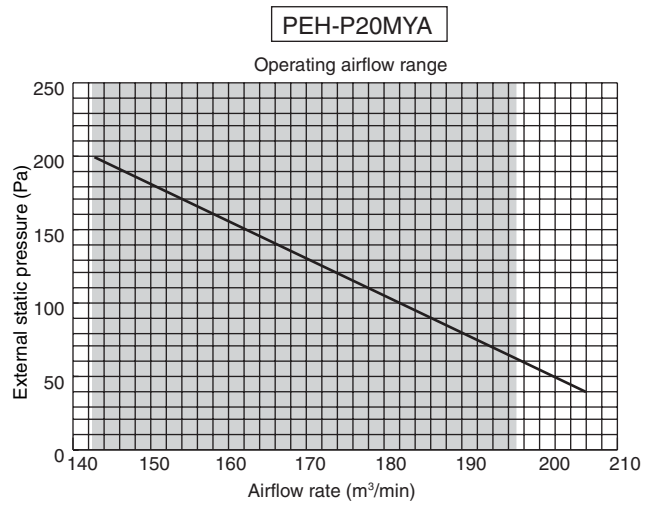
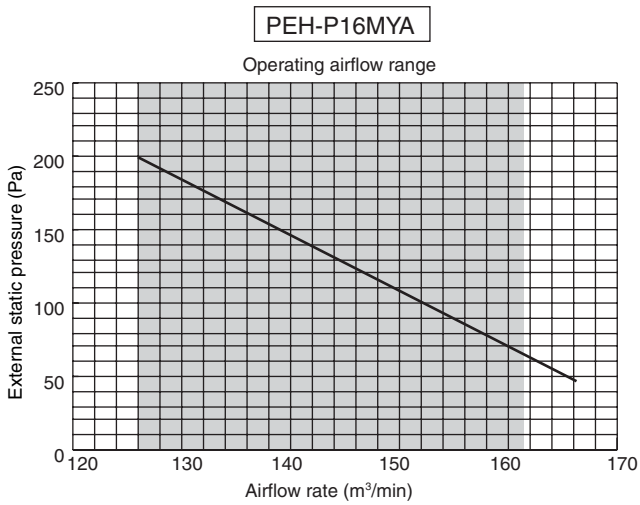
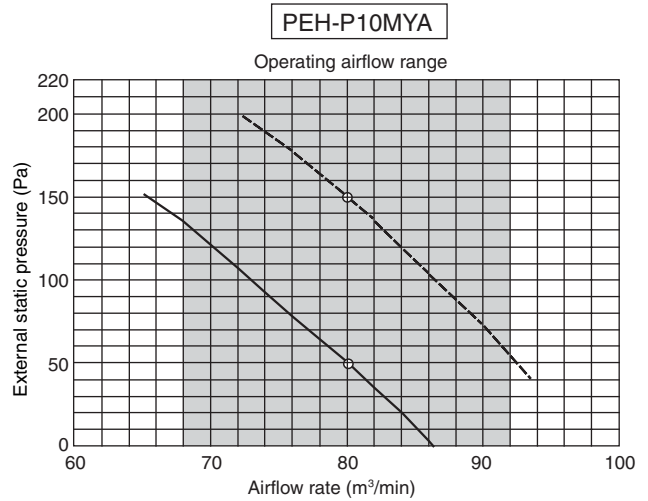
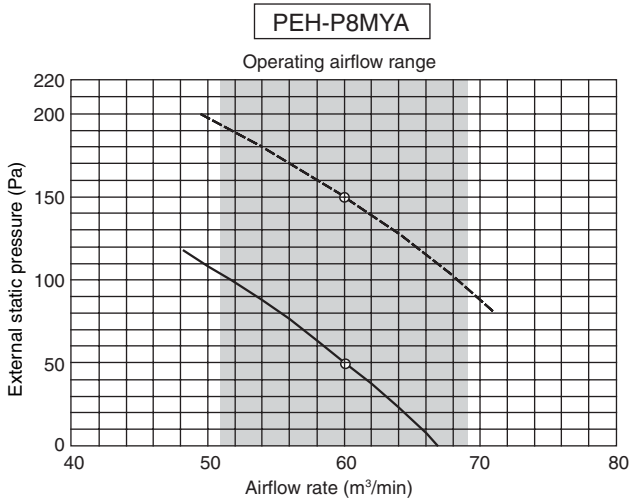

[5] Center of Gravity (Indoor unit)

• Models PEH-P8MYA/P10MYA

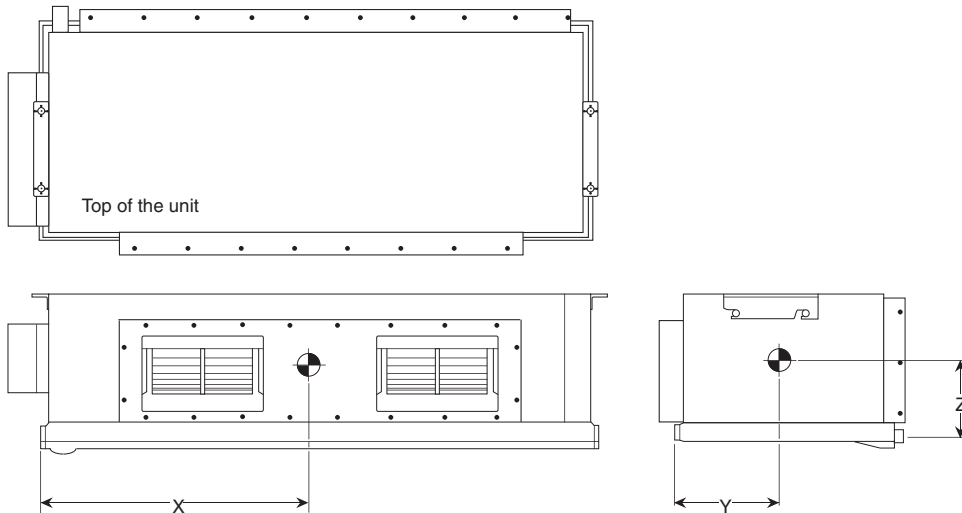

unit : (mm)

Item	Center of gravity		
	X	Y	Z
Model name			
PEH-P8MYA	630	230	240
PEH-P10MYA	730	235	240

• Models PEH-P16MYA/P20MYA

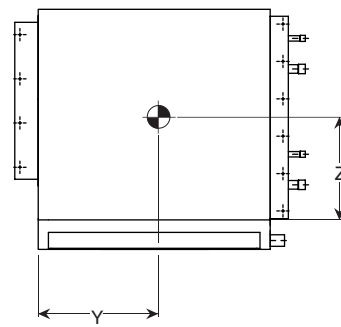
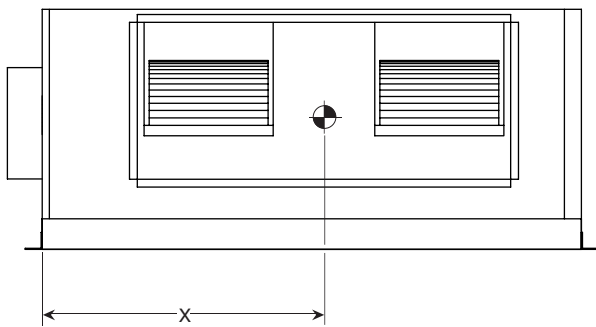
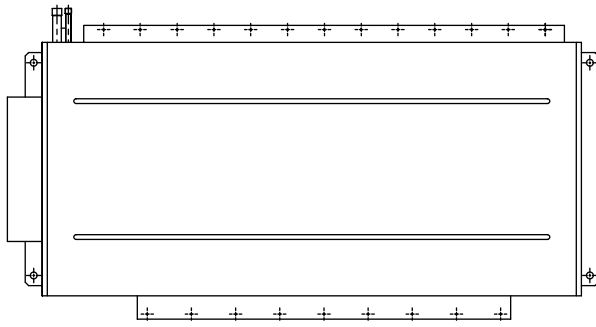

unit : (mm)

Model name	Item	Center of gravity		
		X	Y	Z
PEH-P16MYA		830	420	340
PEH-P20MYA		1015	390	340

[6] NC Curve (Indoor unit)

PEH-P8MYA

Measurement condition

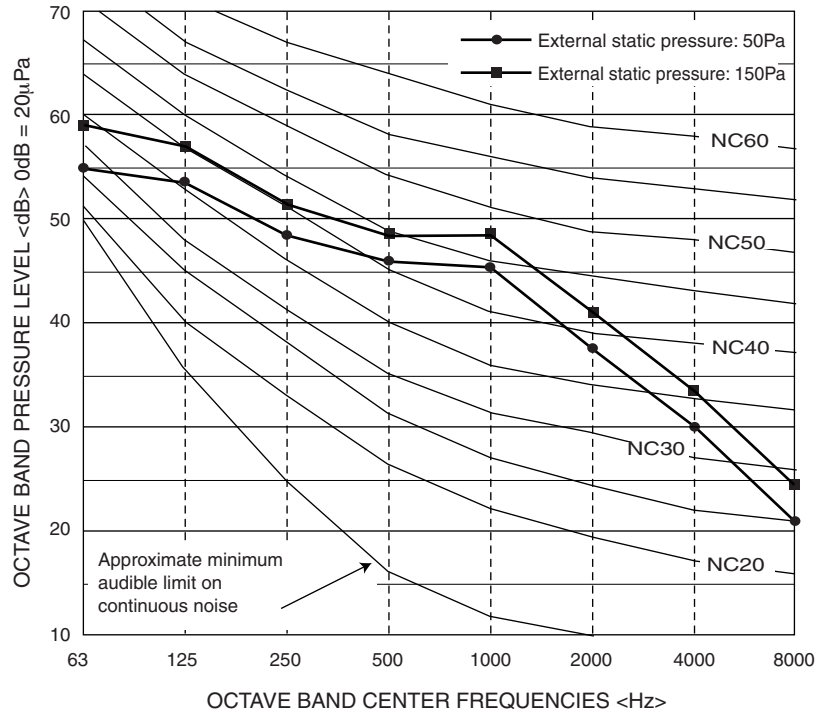
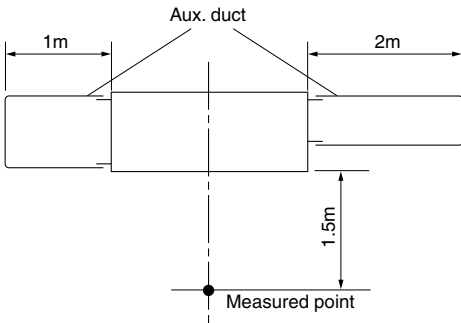

PEH-P10MYA

Measurement condition

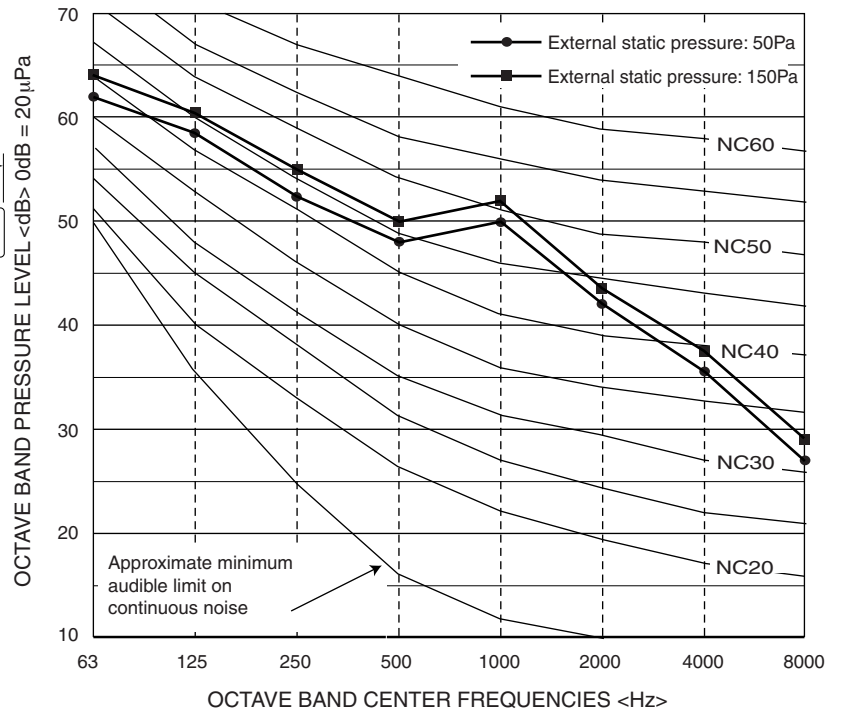
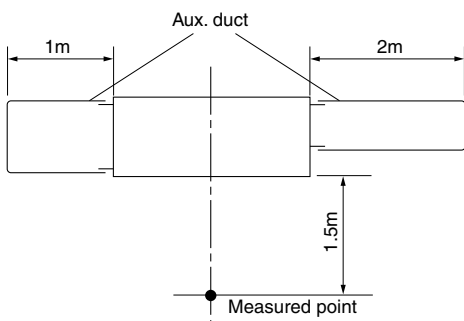

PEH-P16MYA

Measurement condition

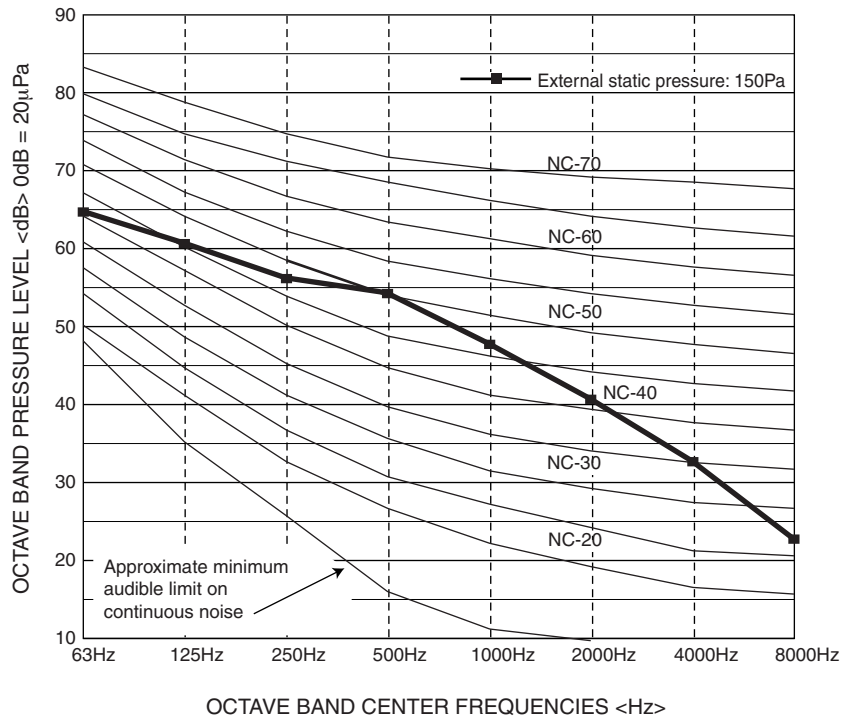
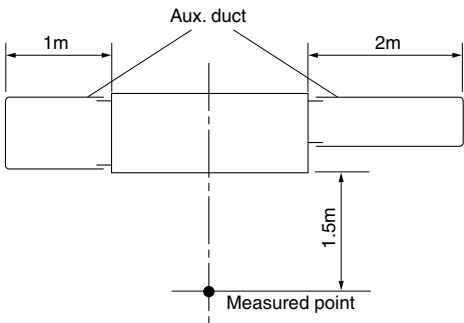

PEH-P20MYA

Measurement condition

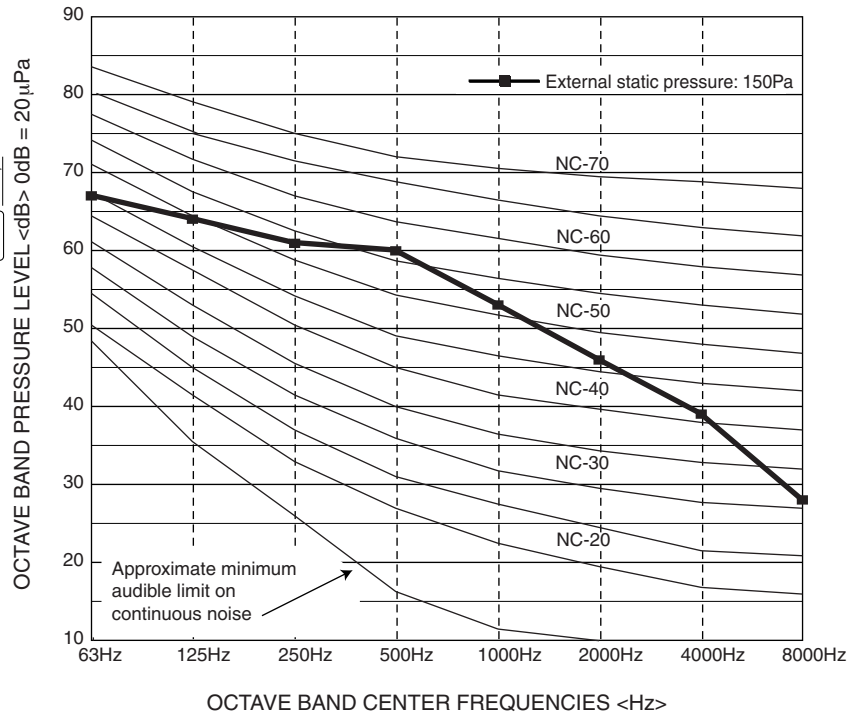
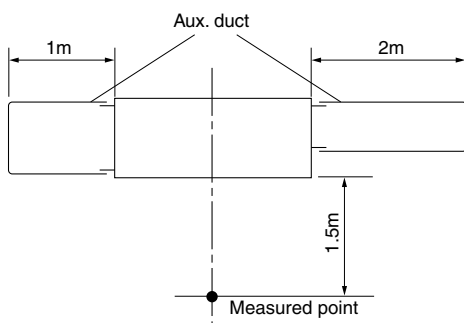

7 SERVICE DATA

[1] Appearance of Equipment

• PEH-P8MYA/P10MYA Electrical Parts Box (with cover removed)

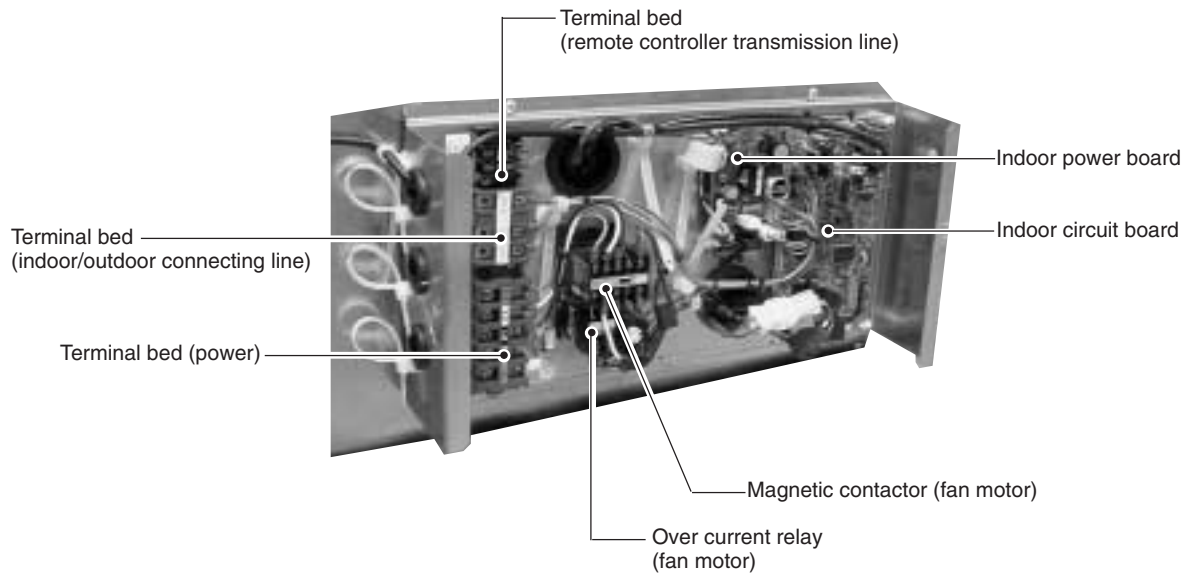

• PEH-P16MYA/P20MYA Electrical Parts Box (with cover removed)

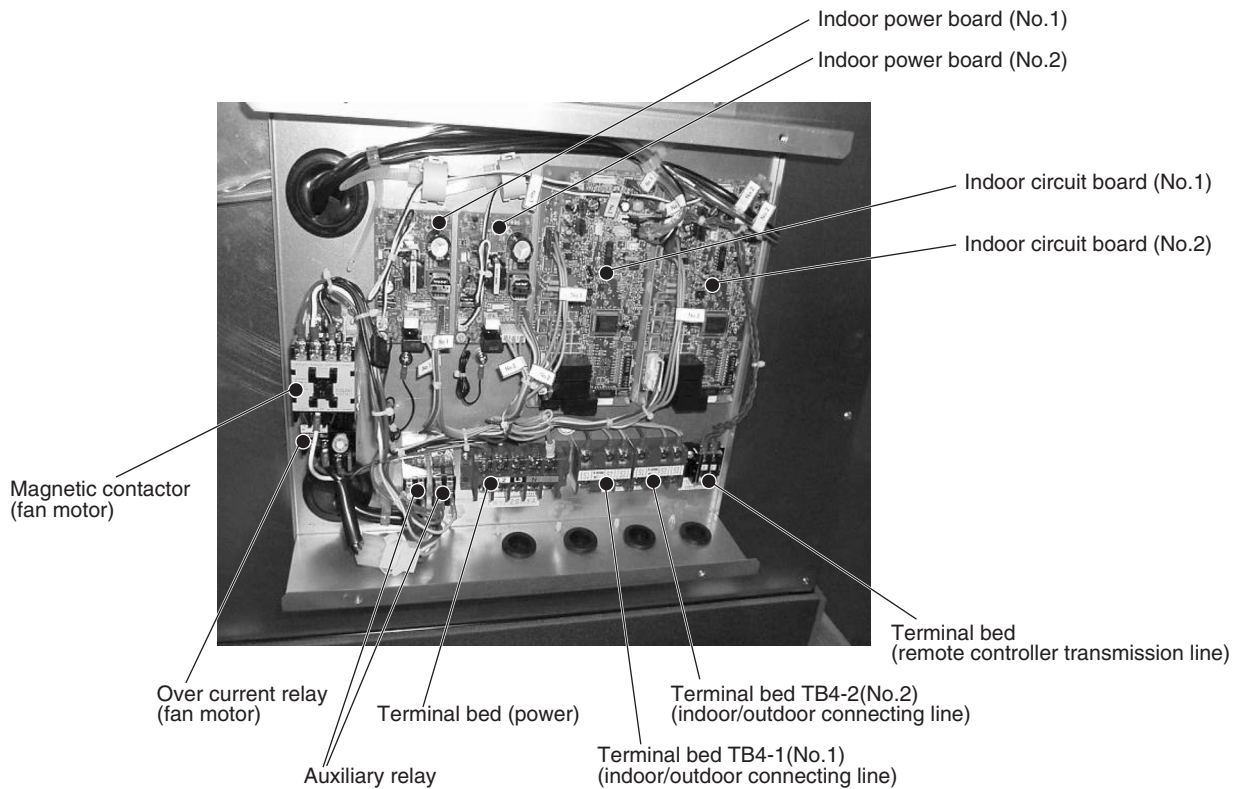

[2] Internal Construction

• PEH-P8MYA/P10MYA (Indoor unit)

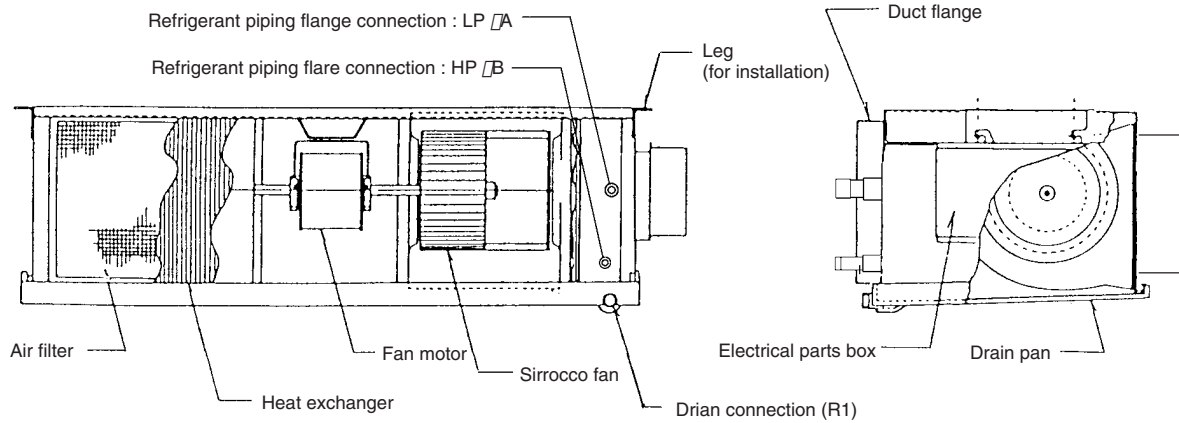

Model name	A	B
PEH-P8MYA/P16MYA	25.4	12.7
PEH-P10MYA/P20YMA	28.58	12.7

• PEH-P16MYA/P20MYA (Indoor unit)

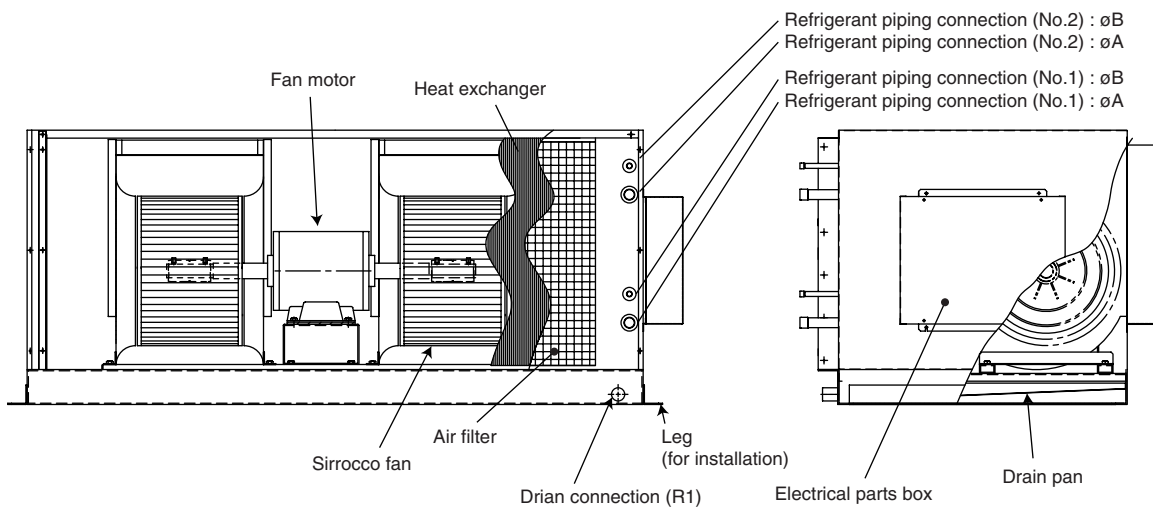

[3] Refrigerant Circuit

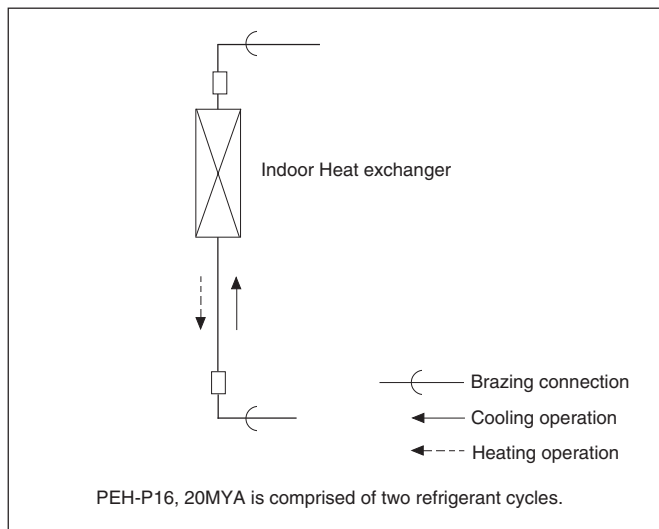

8 FUNCTION OF SWITCH ON INDOOR CIRCUIT BOARD

[1] DIP SW1 for model Selection (DIP SW1 has been set at factory)



OFF
PEH-P8MYA/P10MYA/P16MYA/P20MYA : SW1-1, -4 ON, SW1-2, -3, -5 OFF

[2] DIP SW2 for Capacity Setting (DIP SW2 has been set at factory)

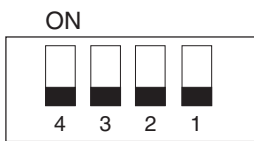

OFF
PEH-P8MYA/P16MYA : SW2-1, -2, -3 and, -4 OFF



OFF
PEH-P10MYA /P20MYA: SW2-1 ON, SW2-2, -3, and, -4 OFF

[3] DIP SWE for Emergency Operation

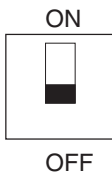

OFF

When SWE is turned ON, FAN turns ON. Setting of emergency operation other than SWE is performed at the outdoor unit. For a description of the specific emergency operation execution method, refer to the outdoor unit (PUH-P8MYA, PUH-P10MYA) Technical & Service Manual.

9 Test run

[1] Before test run

The test run can be carried out either from the outdoor unit or the indoor unit.

1. Check list

- After the installation, piping setup, and wiring of the indoor and outdoor units is complete, check that refrigerant is not leaking, the power and control wires are not loose, and the poles are not reversed.
- Use a 500 V insulation resistance tester to make sure that the resistance between the power terminal and the ground is 1.0 M or more. If it is less than 1.0 M, do not operate the unit. *Absolutely do not touch the tester to indoor/outdoor connection terminals S1, S2, and S3. An accident could occur.
- Make sure there is no malfunction in the outdoor unit. (If there is a malfunction, you can diagnose it using LED2 on the board.)
- Check that the ball valve is fully open on both the liquid and gas ends.
- Check the electrical power phase. If the phase is reversed, the fan may rotate in the wrong direction or stop, or unusual sounds may be produced.
- Starting at least 12 hours before the test run, send current through the crankcase heater. (If the current is running for a shorter period of time, damage to the compressor could result.)
- For specific models requiring changing of settings for higher ceilings or selection of power supply ON/OFF capability, make proper changes referring to the description for Selection of Functions through Remote Controller. After the above checks are complete, carry out the test run as indicated in the following outline.

[2] Test run procedures

1. Indoor unit

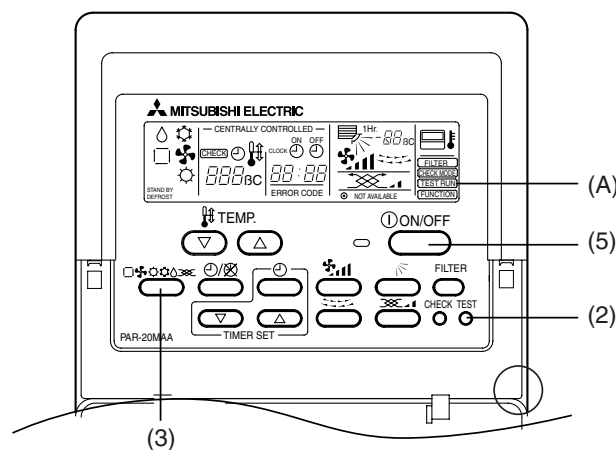

Operating procedures

(1) Turn on the main power supply

While the room temperature display on the remote controller reads "CENTRALLY CONTROLLED", the remote controller is disabled. Turn off the "CENTRALLY CONTROLLED" display before using the remote controller.

(2) Press "TEST RUN" button twice

(A) The 'TEST RUN' indicator should light up.

(3) Press button

Cooling/drying mode : Cool air should start to blow.

Heating mode : Warm air should start to blow (after a while).

(4) Check the outdoor unit fan for correct running



The outdoor unit features automatic capacity control to provide optimum fan speeds. The fan keeps running at a low speed to meet the current outside air condition unless it exceeds its available maximum power. Then, in actuality, the fan may stop or run in the reverse direction depending on the outside air, which does not mean malfunction.

(5) Press the "ON/OFF" button to reset the test run in progress

- The test run will be automatically shut down after two hours in response to the AUTO STOP setting of two hours on the timer.
- During the test run, the room temperature display shows the indoor unit tubing temperatures.

- In the case of the test run, the OFF timer will activate, and the test run will automatically stop after two hours.
- The room temperature display section shows the control temperature for the indoor units during the test run.
- Check that all the indoor units are running properly for simultaneous twin and triple operation.
Malfunctions may not be displayed even if the wiring is incorrect.

(*1)

After turning ON the power, the system will go into startup mode, and the remote controller operation lamp (red) and the room temperature display section's "H0" will flash. Also, in the case of the indoor substrate LEDs, LED 1 and LED 2 light up (when address is 0) or become dim (when address is not 0), and LED 3 flashes. In the case of the outdoor substrate LED display,  and  are displayed alternatively at 1-second intervals.

- If one of the above operations does not function correctly, the following causes should be considered, and if applicable, dealt with. (The following symptoms have been determined under test run mode. Note that "startup" in the chart means the *1 display above.)

Symptoms		Cause
Remote Controller Display	Outdoor Substrate LED Display	
Remote controller is displaying "H0", and operation is not possible.	After "startup" display, "00" is displayed (correct operation).	• After power is turned ON, system startup lasts for about 2 mins., and "H0" is displayed (correct operation).
After power is turned ON, "H0" is displayed for 3 mins., then error code is displayed.	After "startup" display, error code is displayed.	• Outdoor unit 's safeguard installation connector is open. • Negative phase and open phase of outdoor unit's power terminal board. (Single phase: L, N, ⊕/triple phase: L1, L2, L3, N, ⊕)
	After "startup" display, "F1" (negative phase) is displayed.	• Incorrect connection of outdoor terminal board (Single phase: L, N, ⊕/triple phase: L1, L2, L3, N, ⊕) grounding and S1, S2, S3)
Power is turned ON, and "EE" or "EF" are displayed after "H0" is displayed.	After "startup" display, "00" or "EE" is displayed ("EE" is displayed when a test run is made).	• Outdoor unit and indoor unit construction differ.
Display messages do not appear even when remote controller operation switch is turned ON (operation lamp does not light up).	After "startup" display, "EA" (error for number of units) or "Eb" (unit number error) is displayed.	• Wiring for the indoor and outdoor unit is not connected correctly. (Polarity is wrong for S1, S2, S3) • Remote controller transmission wire short.
	After "startup" display, "00" is displayed (correct operation).	• There is no outdoor unit for address 0 (address is something other than 0).
	After "startup" display, "00" is displayed (correct operation).	• Remote controller transmission wire burnout.
Operation display appears but soon disappears even when remote controller operations are executed.	After "startup" display, "00" is displayed (correct operation).	• After cancellation of function selection, operation is not possible for about 30 secs. (correct operation).

* Press the remote controller's "CHECK" button twice consecutively to be able to run a self diagnosis. See the chart below for content of error code displays.

LCD	Nonconformity content	LCD	Nonconformity content	LCD	Nonconformity content
P1	Suction sensor error	P8	Tube temperature error	E6 ~ EF	Signal error between indoor and outdoor units
P2	Tubing (liquid) sensor error	P9	Tube (2-phase tube) sensor error		
P4	Drain sensor error	U0 ~ UP	Outdoor unit nonconformity	----	No error history
P5	Drain overflow safeguard operation	F1 ~ FA	Outdoor unit nonconformity	FFFF	No relevant unit
P6	Freezing/overheating safeguard operation	E0 ~ E5	Signal error between remote controller and indoor unit		

See the chart below for details of the LED displays (LED 1, 2, 3) on the indoor substrate.

LED 1 (microcomputer power supply)	Displays the ON/OFF of power for control. Check that this is lit during normal use.
LED 2 (remote controller feed)	Displays the ON/OFF of feed to wired remote controller. Is only lit for indoor unit linked to outdoor unit with address "00".
LED 3 (indoor and outdoor signals)	Displays signal between indoor and outdoor units. Check that this is flashing during normal use.

2. Outdoor unit

(1) Check Items

- After installation of indoor and outdoor units, and piping and electric wiring work, check that the unit is free from leaks of refrigerant, loosened connections, and incorrect polarity.
- Check that there is no negative phase and open phase. (The F1 message for negative phase and the F2 message for open phase will flash at LED 1 on the outdoor substrate. If this happens, rewire correctly.)
- Measure the impedance between power terminals (Single phase: L, N, ⊕/triple phase: L1, L2, L3, N, ⊕) and the ground with a 500 V Megger and check that it is 1.0 M or more. Do not operate the equipment if measurement is less than 1.0 M. *Never conduct this operation on the outdoor connection wiring terminals (S1, S2, S3) as this causes damage.

- When there is no error at the outdoor unit. (If there is an error at the outdoor unit, it can be evaluated at LED 1 [digital display] of the outdoor substrate.)
- The stop valves are open both the liquid and gas sides.
After checking the above, execute the test run in accordance with the following.

(2) Test run start and finish

- Operation from the indoor unit
Execute the test run using the installation manual for the indoor unit.
- Operation from the outdoor unit
Execute settings for test run start, finish and operation mode (cooling, heating) using the DIP switch SW 4 on the outdoor substrate.

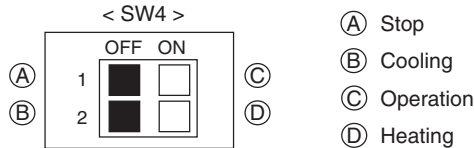

- Set the operation mode (cooling, heating) using SW 4-2
 - Turn ON SW 4-1, The operation mode for SW 4-2 will be adhered to, and the test run will commence
 - Turn OFF SW 4-1 to finish the test run
- There may be a faint knocking noise emitted from the proximity of the fan during the test run. This is torque fluctuation occurring due to control of fan revolutions. There is no problem with the product.

Note:

The SW 4-2 operation mode cannot be changed during the test run. (To change test run mode, stop the equipment with SW 4-1, change the operation mode, then restart test run with SW 4-1.)

- If the 2-hour timer is set, the test run will stop automatically after 2 hours.
- During the test run, the room temperature display on the indoor unit will indicate the temperature of the indoor unit piping.

[3] Self-diagnosis

Use the remote controller to look up each units error history.

1.

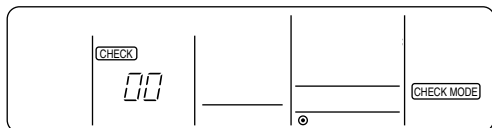

1. Change to self-diagnosis mode

Press the CHECK button twice within three seconds to show the following

2.

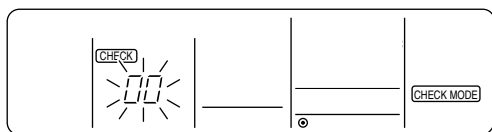

2. Select the refrigerant address number to be self-diagnosed

Press the buttons to scroll through the refrigerant address numbers (00 to 15) and select the refrigerant address number to be self-diagnosed.

After three seconds from making the change, the lit refrigerant address to be self-diagnosed will start to flash, and self-diagnosis will commence.

3. (1)

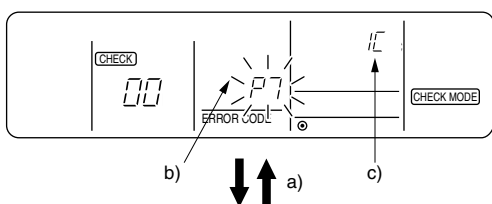

3. Self-diagnosis result display

See the above chart for details of error code contents.

(1) When there is an error history

- Alternating display
- Error code
- Attribute of error search
- Unit number

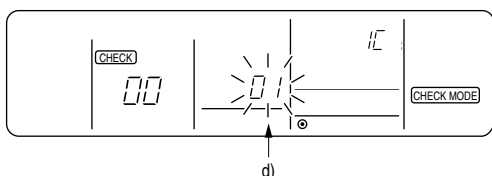

3. (2)

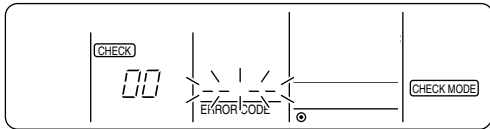

(3)

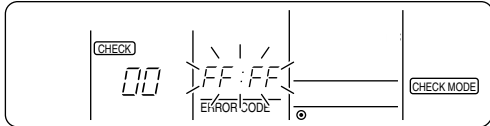

4.

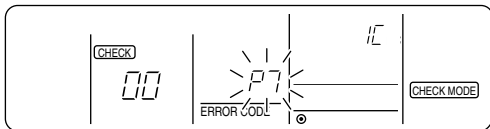

↑ ↓ a)

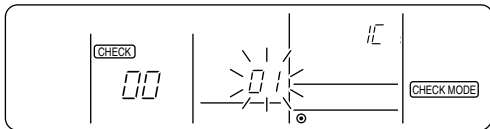

5.

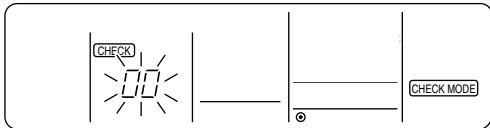

↓

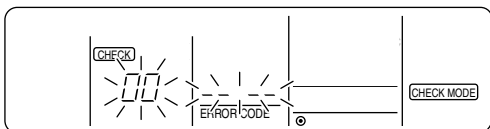



(2) When there is no error history

(3) When the address does not exist

4. Reset error history

Display the error history at the self-diagnosis result display screen 3.

The address for self-diagnosis will flash when the  →  →  button is pressed twice within three seconds.

The diagram on the left will be displayed when error history has been reset.

Note that the error content will be redisplayed if error history resetting is unsuccessful.

a) Alternating display

5. Canceling self-diagnosis

The following two methods can be used to cancel self-diagnosis. Press the CHECK button twice within three seconds to cancel self-diagnosis. The display screen will return to the status before self-diagnosis. Press the 1 ON/OFF button to cancel self-diagnosis. The indoor unit will stop. (This operation is ineffectual when operation is prohibited.)

[4] Remote controller diagnosis

If operation cannot be carried out from the remote controller, use this function to diagnose the remote controller.

1.

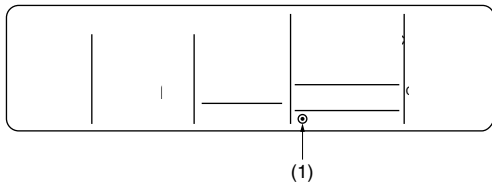

2.

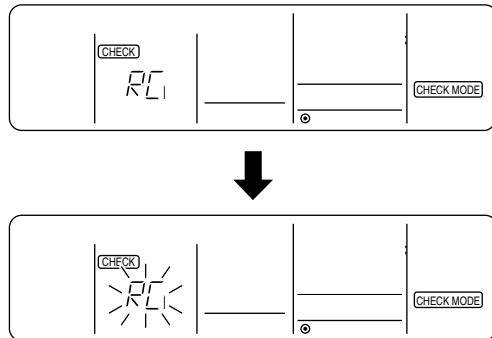

3. (1)

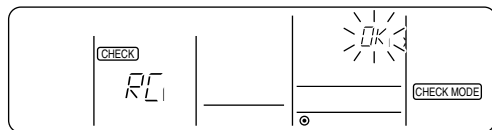

(2)

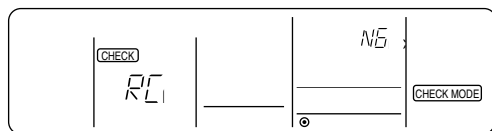

(1)

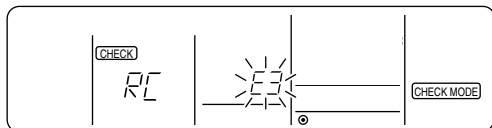

(2)

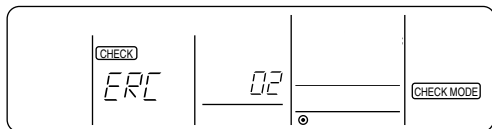

K) When the number of data errors generated is 02

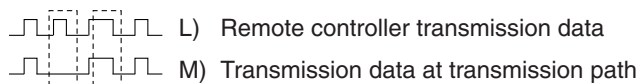

L) Remote controller transmission data

M) Transmission data at transmission path

4. Cancel the remote controller diagnosis

Hold down the CHECK button for five seconds or more to cancel the remote controller diagnosis. The "H0" operation lamp will flash, and the display screen will return to the status before remote controller diagnosis in approximately 30 seconds.

1. First, check the electricity current marker

If the correct voltage (DC 12 V) is not displayed on the remote controller, the electric current marker will be lit. If the electricity current marker is not lit, check the remote controller wiring and the indoor unit.

(1) Electric current marker

2. Transfer to remote control mode

Hold down the CHECK button for five seconds or more to display the diagram on the left.

Press the FILTER button to commence diagnosis of remote controller.

3. Remote controller diagnosis results

(1) The remote control is functioning correctly.

Check other possible causes as there are no problems with the remote controller.

(2) The remote controller has a nonconformity.

The remote controller must be replaced.

Error display 1 ("NG") flashes to show a nonconformity in the transmitter-receiver circuit.

Potential problems other than those diagnosed for the remote controller.

(1) Single transmission not possible if error display 2 ("E3") flashes.

There is "noise" on the transmission line, or damage of other remote controllers for the indoor units can be considered. Check the transmission path and other controllers.

(2) Data error has occurred when error display three shows "ERC" and number of data errors.

Number of generated data errors (maximum 66 errors). The number of generated data errors stands for the difference in the number of bits of transmitted data from the remote controller and the actual number of bits that were transmitted along the transmission path. If this error occurs, "noise", etc., is interfering with the transmission data. Check the transmission path.

— MEMO —

— MEMO —

— MEMO —



Certificate Number FM33568

The Air Conditioning & Refrigeration Systems Works acquired ISO 9001 certification under Series 9000 of the International Standard Organization (ISO) based on a review of quality warranties for the production of refrigeration and air conditioning equipment.

ISO Authorization System

The ISO 9000 series is a plant authorization system relating to quality warranties as stipulated by the ISO. ISO 9001 certifies quality warranties based on the "design, development, production, installation and auxiliary services" for products built at an authorized plant.



Certificate Number EC97J1227
Registered on March 10, 1998

The Air Conditioning & Refrigeration Systems Works acquired environmental management system standard ISO 14001 certification.

The ISO 14000 series is a set of standards applying to environmental protection set by the International Standard Organization (ISO). ISO 14001 certifies the plant's environmental protection system and activities.

MITSUBISHI ELECTRIC CORPORATION

HEAD OFFICE MITSUBISHI DENKI BLDG. MARUNOUCHI TOKYO 100-0005 TELEX J24532 CABLE MELCO TOKYO