



MITSUBISHI ELECTRIC Air-Conditioners

Mr. SLIM

PLA-RP·AA / PUHZ-RP·HA

FOR INSTALLER
FÜR INSTALLATEUR
POUR L'INSTALLATEUR
FÖR INSTALLATÖREN
VOOR DE INSTALLATEUR
PER L'INSTALLATORE
PARA EL INSTALADOR
PARA O INSTALADOR
TIL INSTALLATØREN
ΓΙΑ ΑΥΤΟΝ ΠΟΥ ΚΑΝΕΙ
ΤΗΝ ΕΓΚΑΤΑΣΤΑΣΗ
MONTÖR İÇİN
ДЛЯ УСТАНОВИТЕЛЯ

- (E)** **ILLUSTRATION BOOK FOR INSTALLATION**
This is an illustration book for installation. Install the air conditioner referring to this book and INSTALLATION MANUAL.
- (D)** **BEBILDERTES HANDBUCH ZUR INSTALLATION**
Dies ist ein bebildertes Handbuch zur Installation. Beim Installieren der Klimaanlage dieses Handbuch und das INSTALLATIONSHANDBUCH beachten.
- (F)** **NOTICE ILLUSTRÉE D'INSTALLATION**
Cette notice illustrée concerne l'installation de l'appareil. Installer le climatiseur à l'aide de cette notice et du MANUEL D'INSTALLATION.
- (SD)** **ILLUSTRERAD INSTALLATIONSBOK**
Detta är en illustrerad installationsbok. Hänvisa till den här boken och INSTALLATIONSMANUALLEN när luftkonditioneringen installeras.
- (NL)** **ILLUSTRATIEBOEK VOOR INSTALLATIE**
Dit is een illustratieboek voor installatie. Raadpleeg bij het installeren dit boek en de INSTALLATIEHANDLEIDING.
- (I)** **LIBRETTO ILLUSTRATO PER L'INSTALLAZIONE**
Il presente libretto contiene le illustrazioni per facilitare l'installazione. Installare il condizionatore d'aria facendo riferimento sia a questo libretto che al MANUALE DI INSTALLAZIONE.
- (ES)** **LIBRO DE ILUSTRACIONES PARA LA INSTALACIÓN**
Este libro contiene ilustraciones para facilitar la instalación. Instale el equipo de aire acondicionado siguiendo las instrucciones de este libro y del MANUAL DE INSTALACIÓN.
- (PR)** **LIVRO DE IMAGENS PARA A INSTALAÇÃO**
Este é um livro de imagens para a instalação. Instale o aparelho de ar condicionado de acordo com este livro e o MANUAL DE INSTALAÇÃO.
- (DK)** **ILLUSTRERET HÆFTE TIL BRUG VED INSTALLATION**
Dette er et illustreret hæfte til brug ved installationen. Installer aircondition anlægget ved at benytte dette hæfte samt INSTALLATIONSMANUAL.
- (GR)** **ΟΔΗΓΟΣ ΕΓΚΑΤΑΣΤΑΣΗΣ ΜΕ ΕΙΚΟΝΕΣ**
Αυτός είναι ένας οδηγός για την εγκατάσταση με εικόνες. Εγκαταστήστε το κλιματιστικό σύμφωνα με τις οδηγίες που θα βρείτε εδώ και στο ΕΓΧΕΙΡΙΔΙΟ ΟΔΗΓΙΩΝ ΕΓΚΑΤΑΣΤΑΣΗΣ.
- (TR)** **MONTAJ ŞEMA KİTABI**
Bu bir montaj şema kitabıdır. Klimayı bu kitaba ve MONTAJ ELKİTABI bağlı kalarak monte edin.
- (RU)** **АЛЬБОМ ИЛЛЮСТРАЦИЙ ДЛЯ УСТАНОВКИ**
Этот документ является альбомом иллюстраций для установки. При установке кондиционера пользуйтесь настоящим документом и РУКОВОДСТВОМ ПО УСТАНОВКЕ.

 **MITSUBISHI
ELECTRIC**



2

(mm)

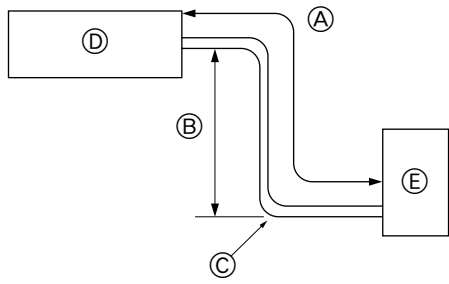

Fig. 2-1

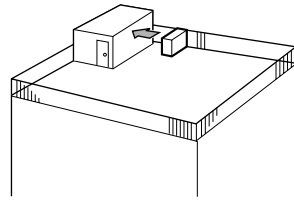

Fig. 2-2

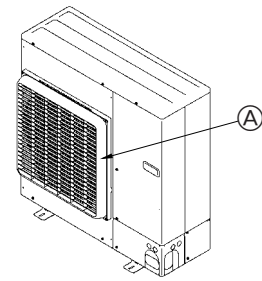

Fig. 2-3

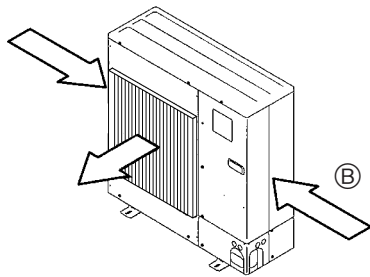

Fig. 2-4

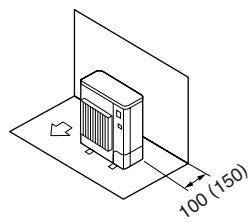

Fig. 2-5

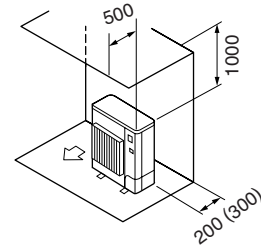

Fig. 2-6

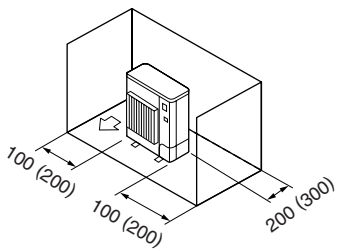

Fig. 2-7

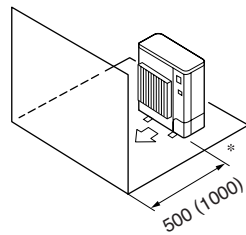

Fig. 2-8

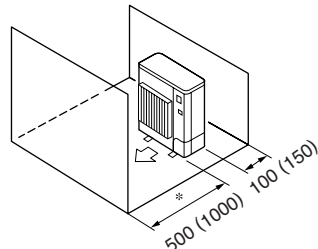

Fig. 2-9

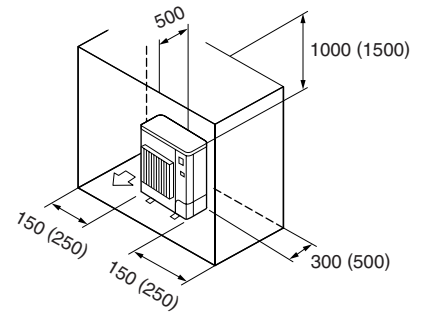

Fig. 2-10

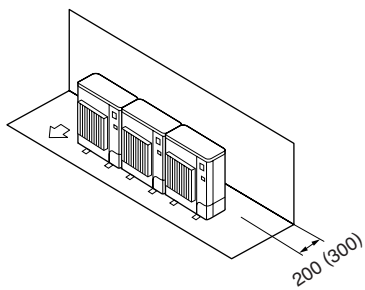

Fig. 2-11

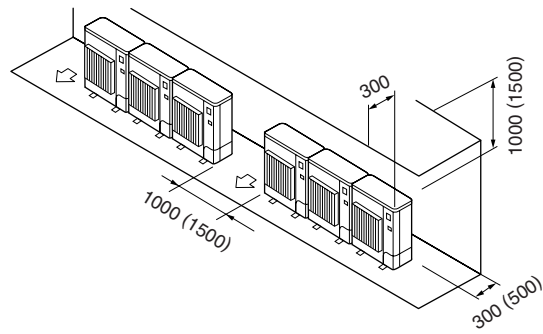

Fig. 2-12

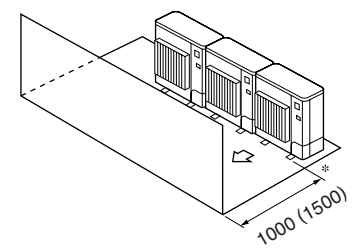

Fig. 2-13

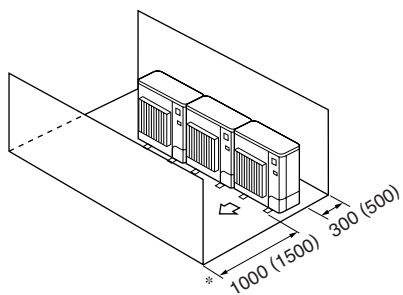

Fig. 2-14

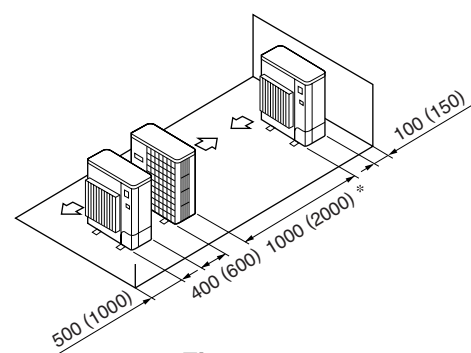

Fig. 2-15

2



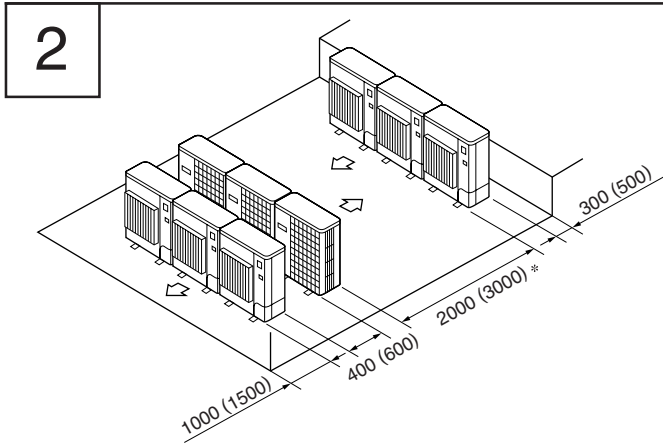

Fig. 2-16

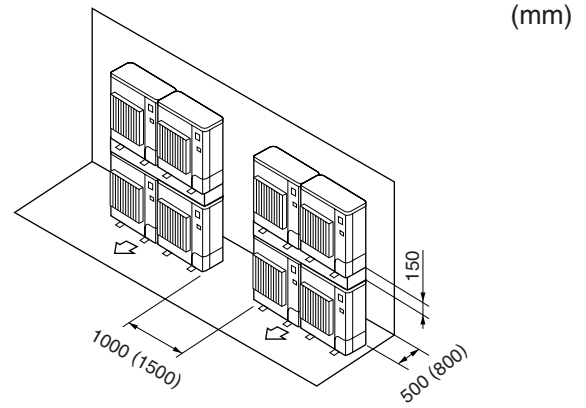

Fig. 2-17

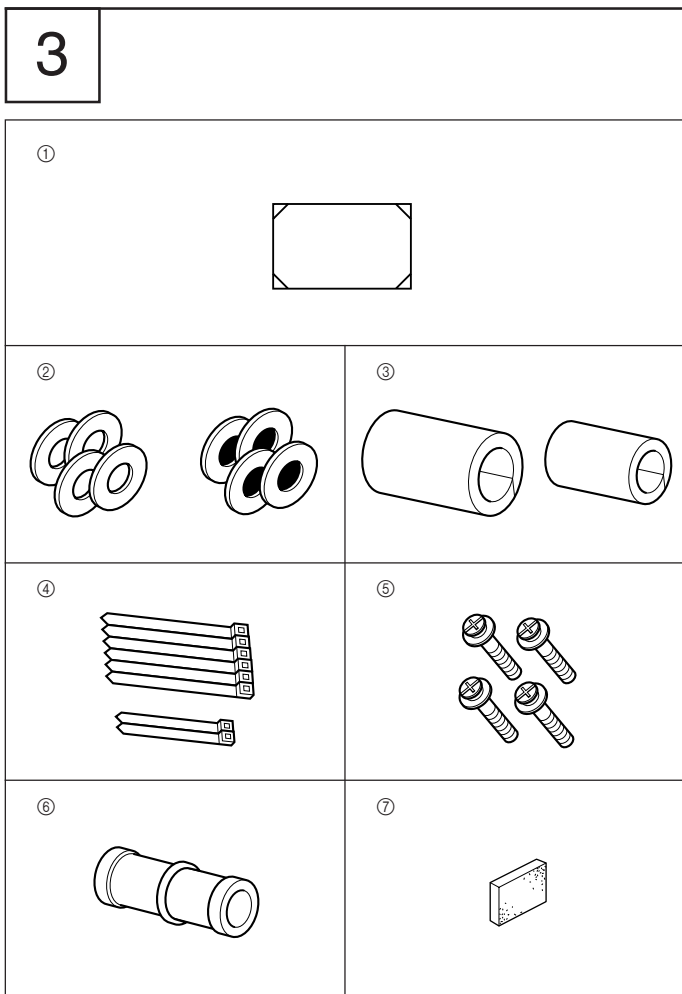

Fig. 3-1

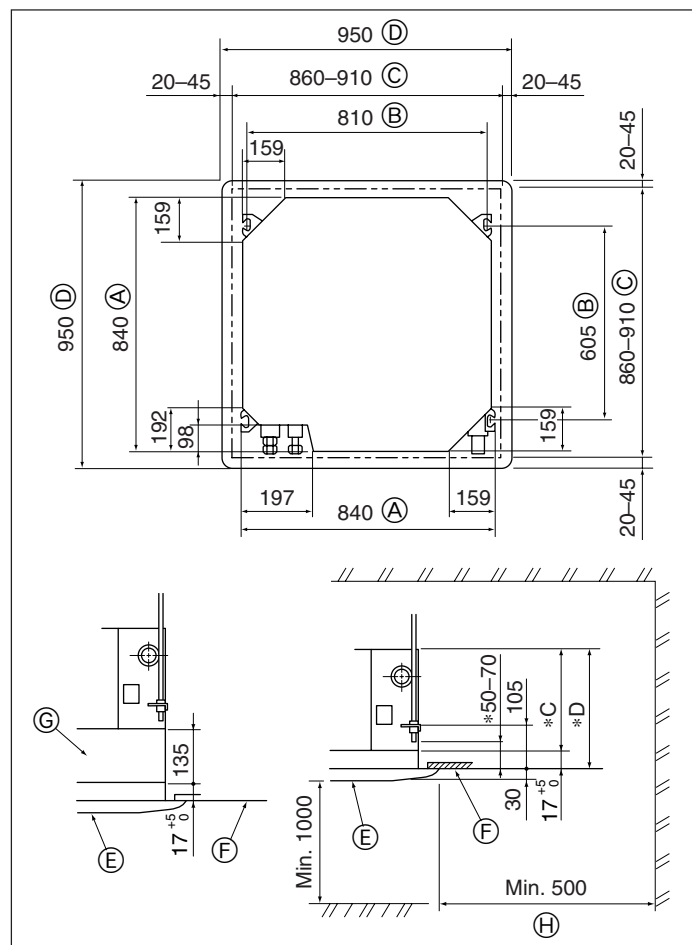

Fig. 3-2

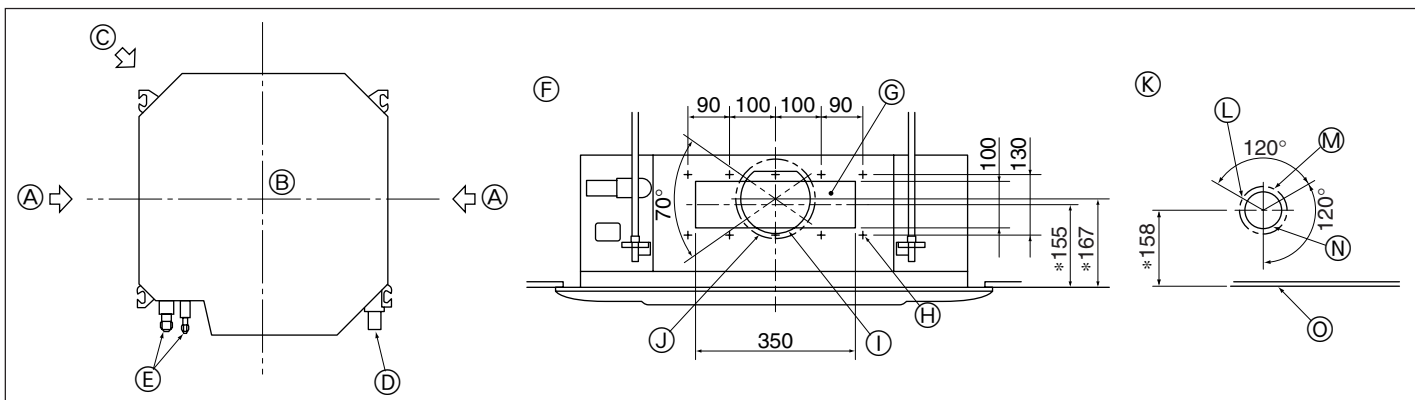

Fig. 3-3





3

(mm)

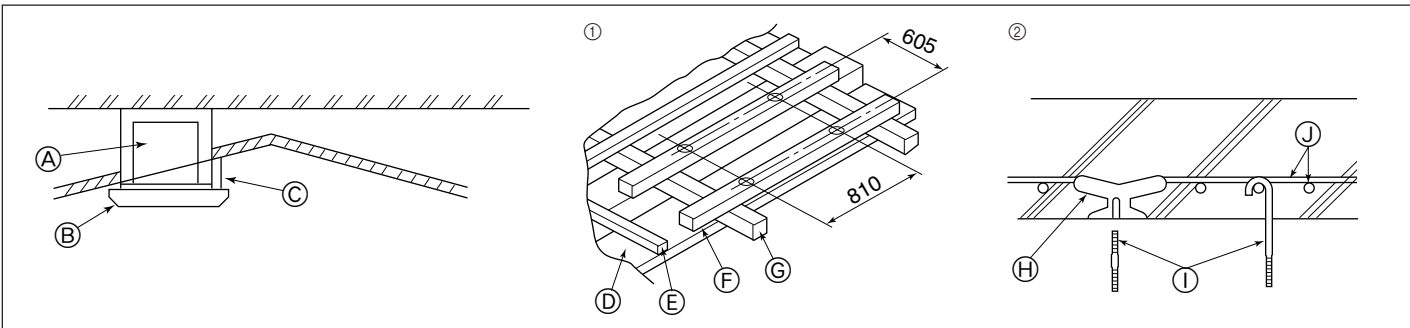

Fig. 3-4

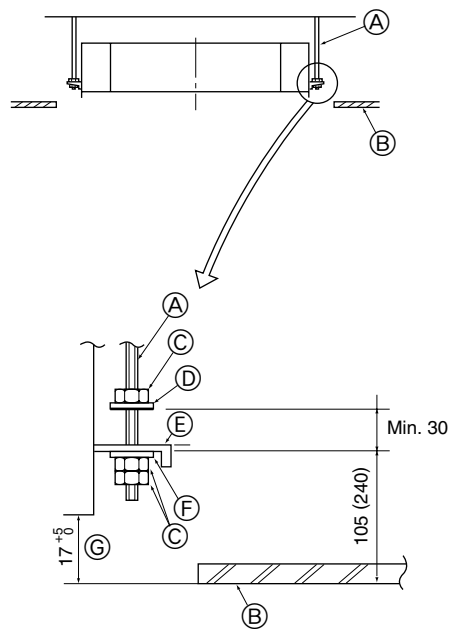

Fig. 3-5

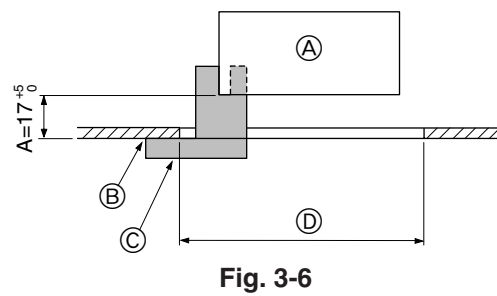

Fig. 3-6

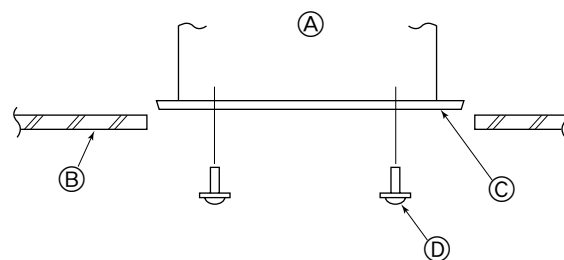

Fig. 3-7

4

(mm)

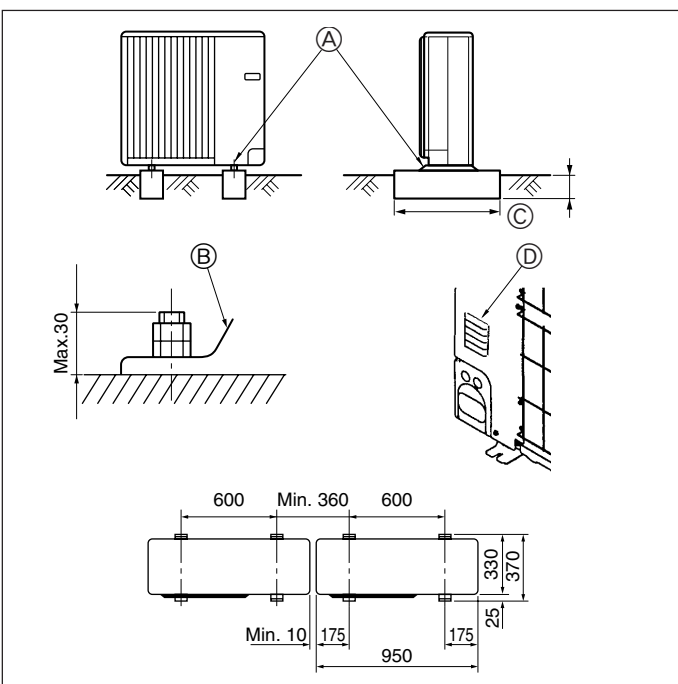

Fig. 4-1

4

5

(mm)

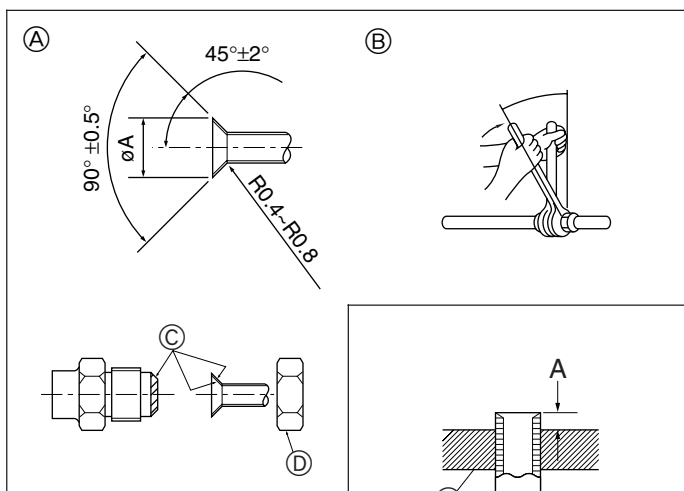

Fig. 5-1

Fig. 5-2





5

(mm)

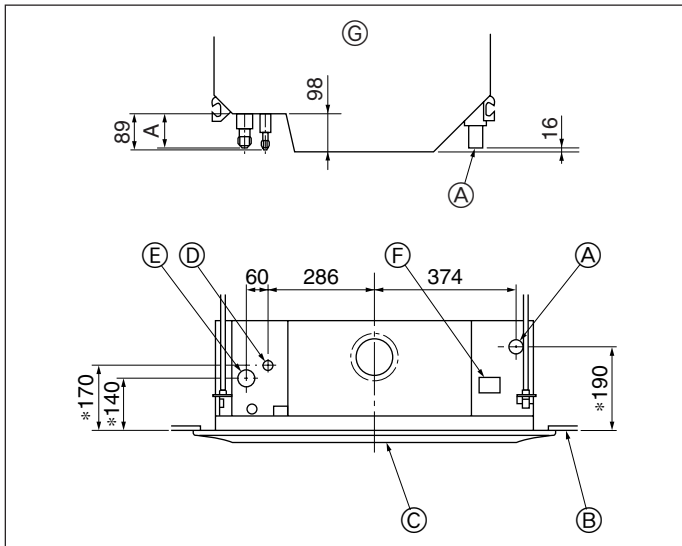

Fig. 5-3

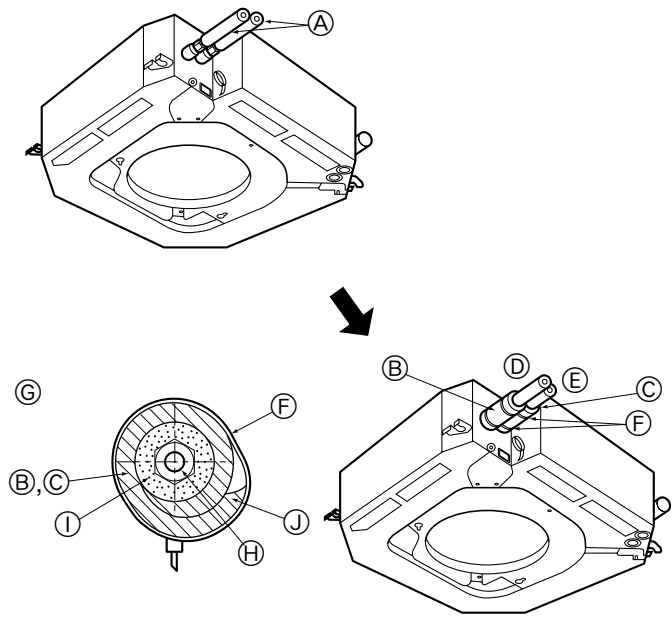

Fig. 5-4

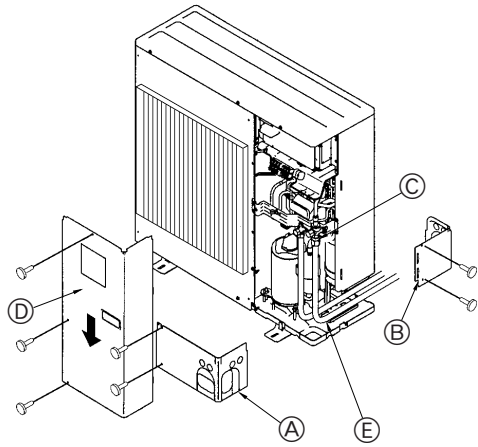

Fig. 5-5

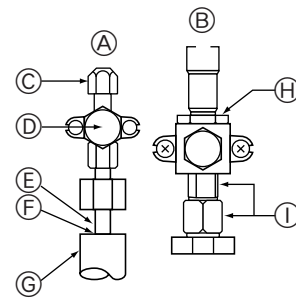

Fig. 5-6

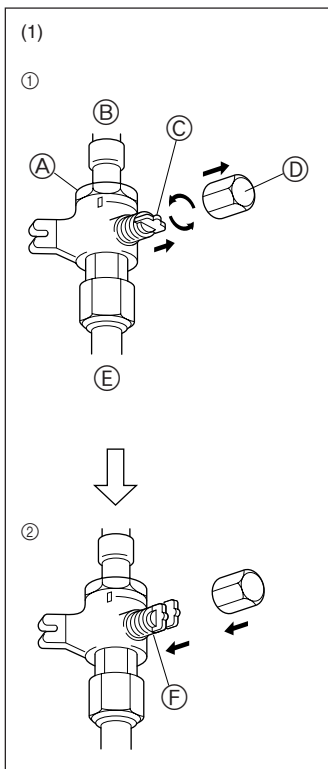

Fig. 5-7

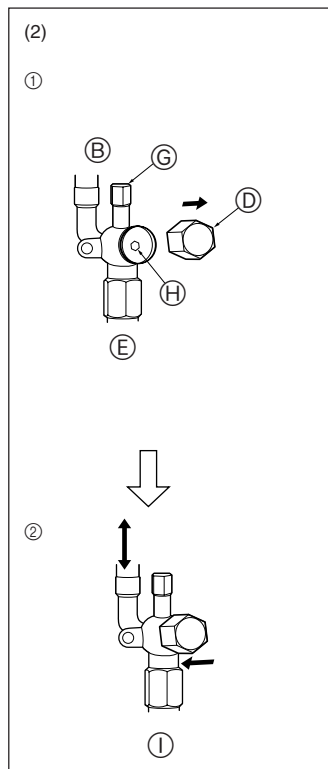

Fig. 5-8

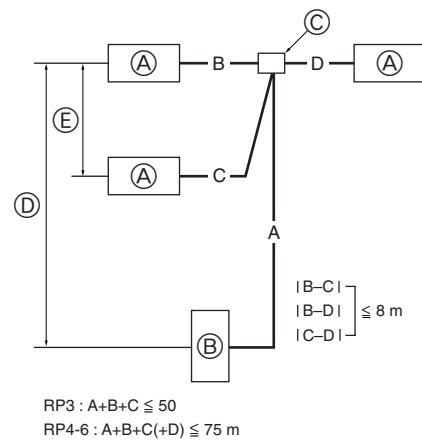

Fig. 5-9



6

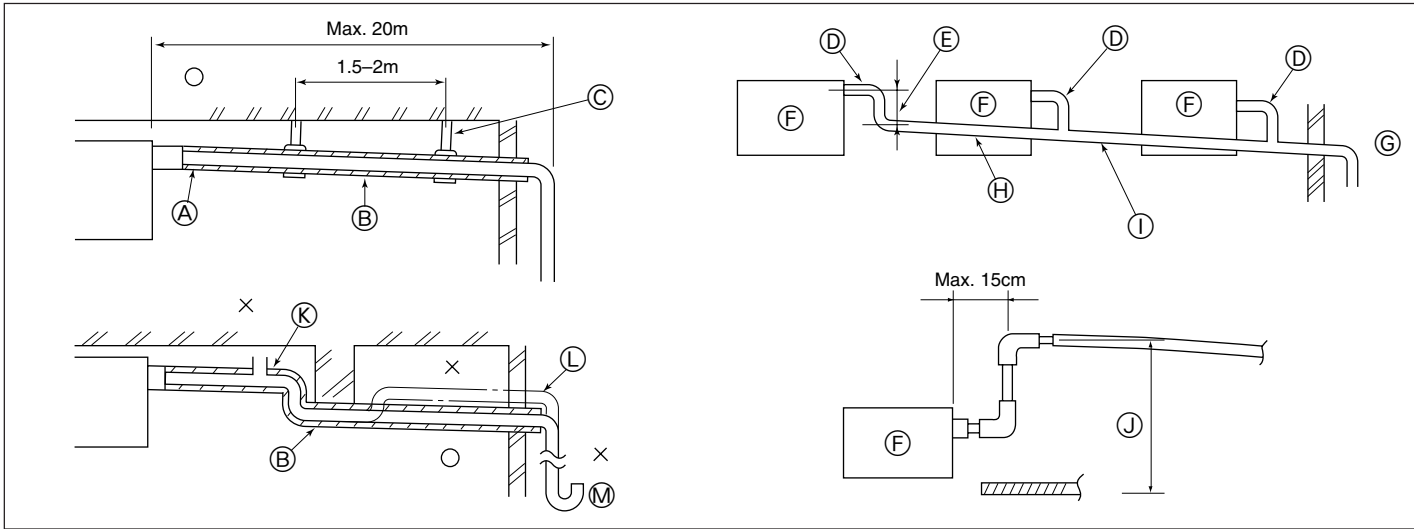

Fig. 6-1

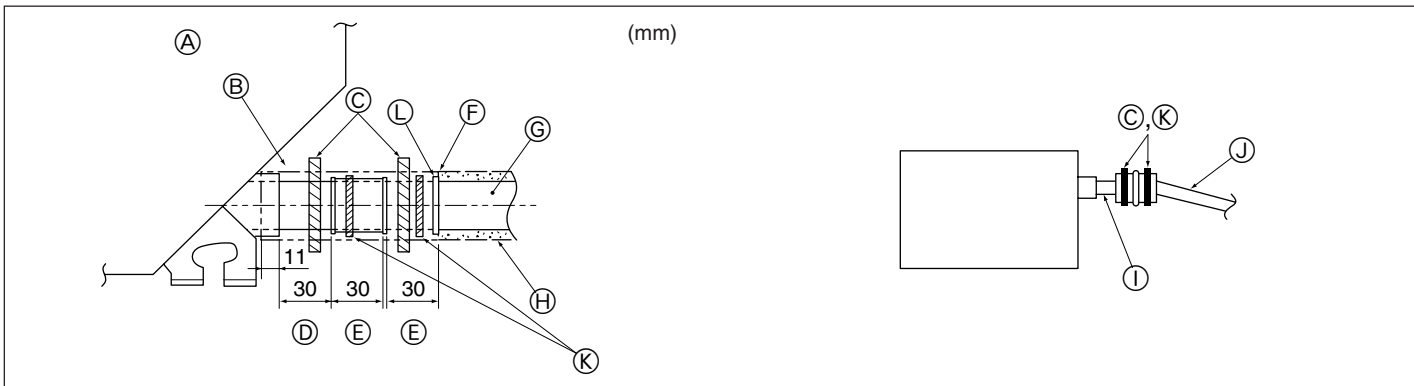

Fig. 6-2

7

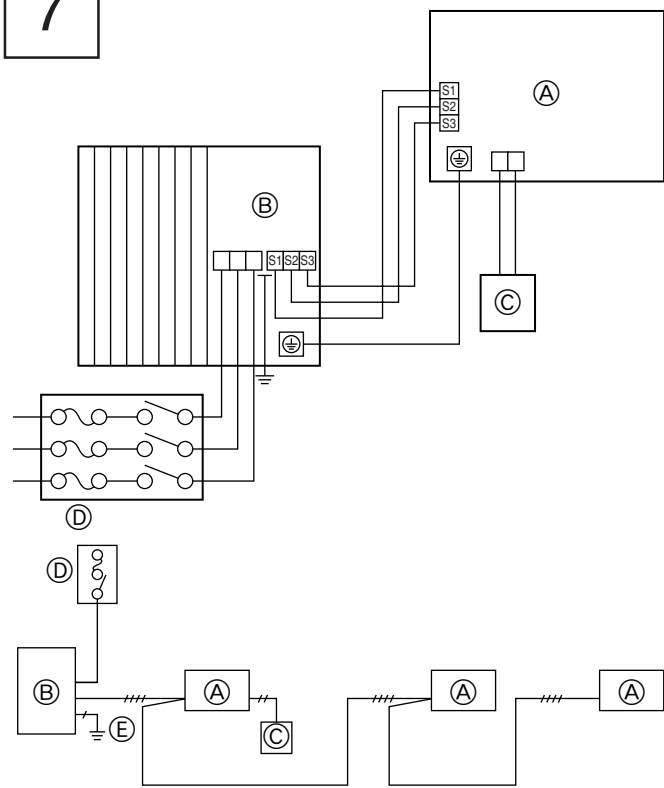

Fig. 7-1

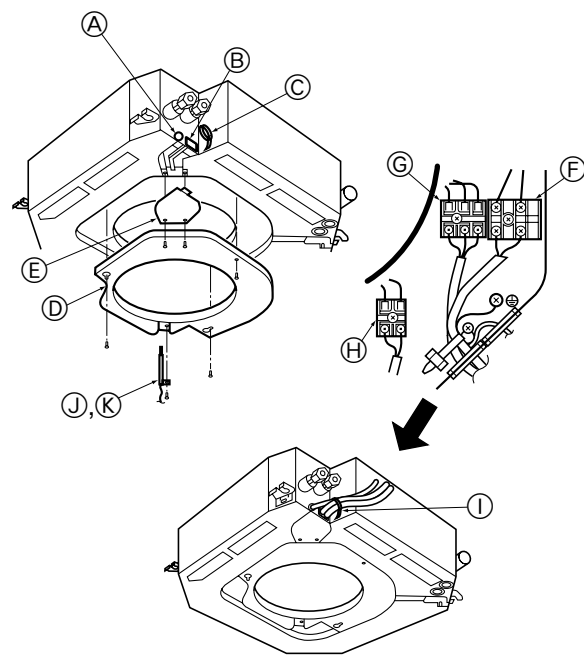

Fig. 7-2

6

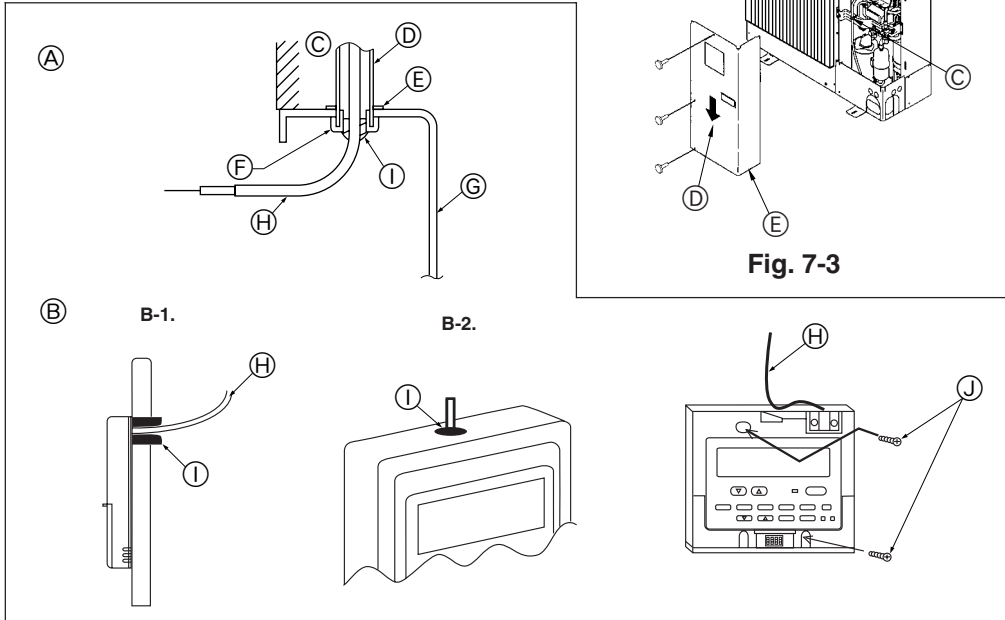

Fig. 7-5

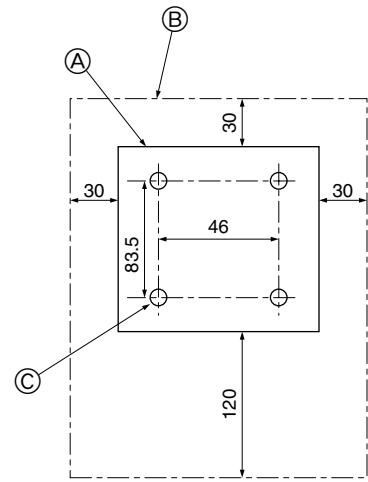

Fig. 7-4

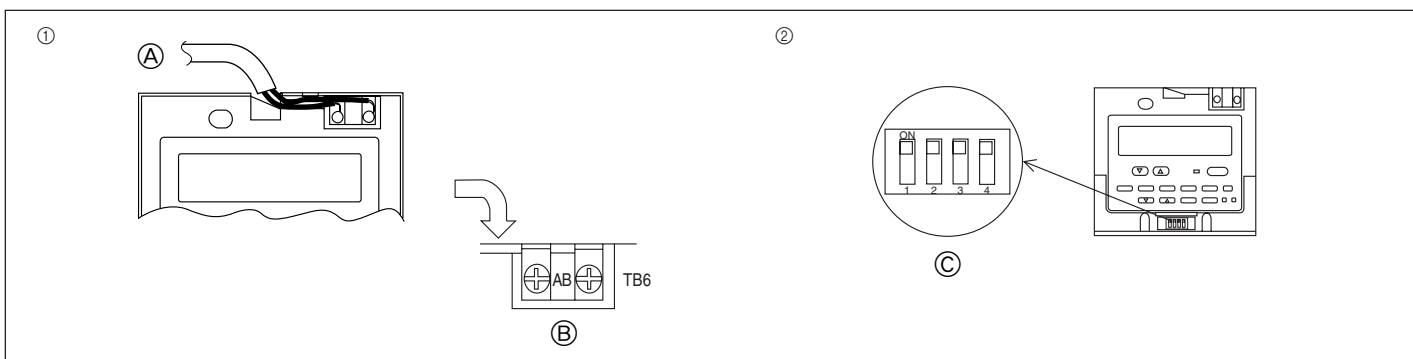

Fig. 7-6

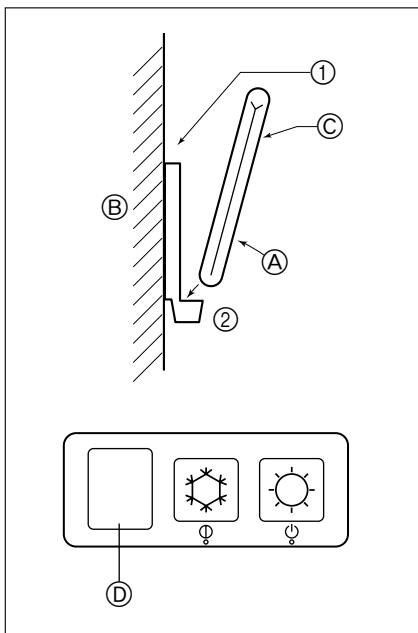

Fig. 7-7

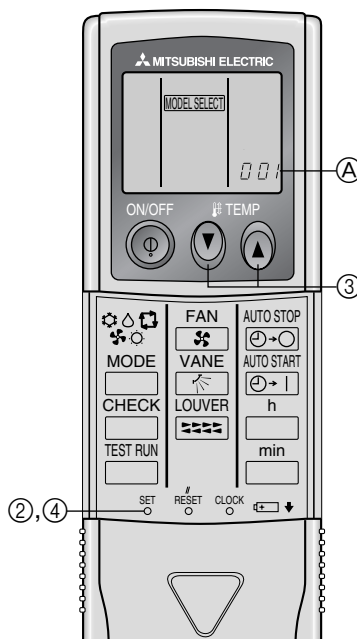

Fig. 7-8

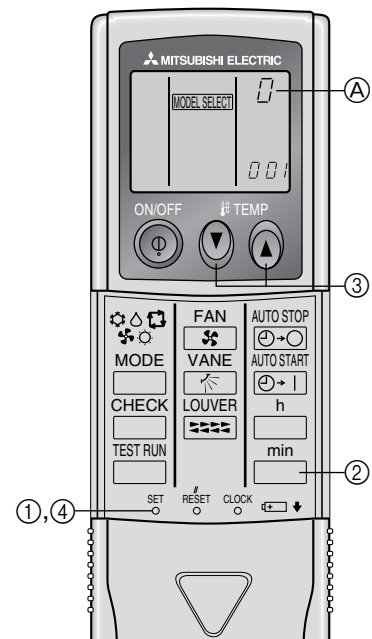

Fig. 7-9



7

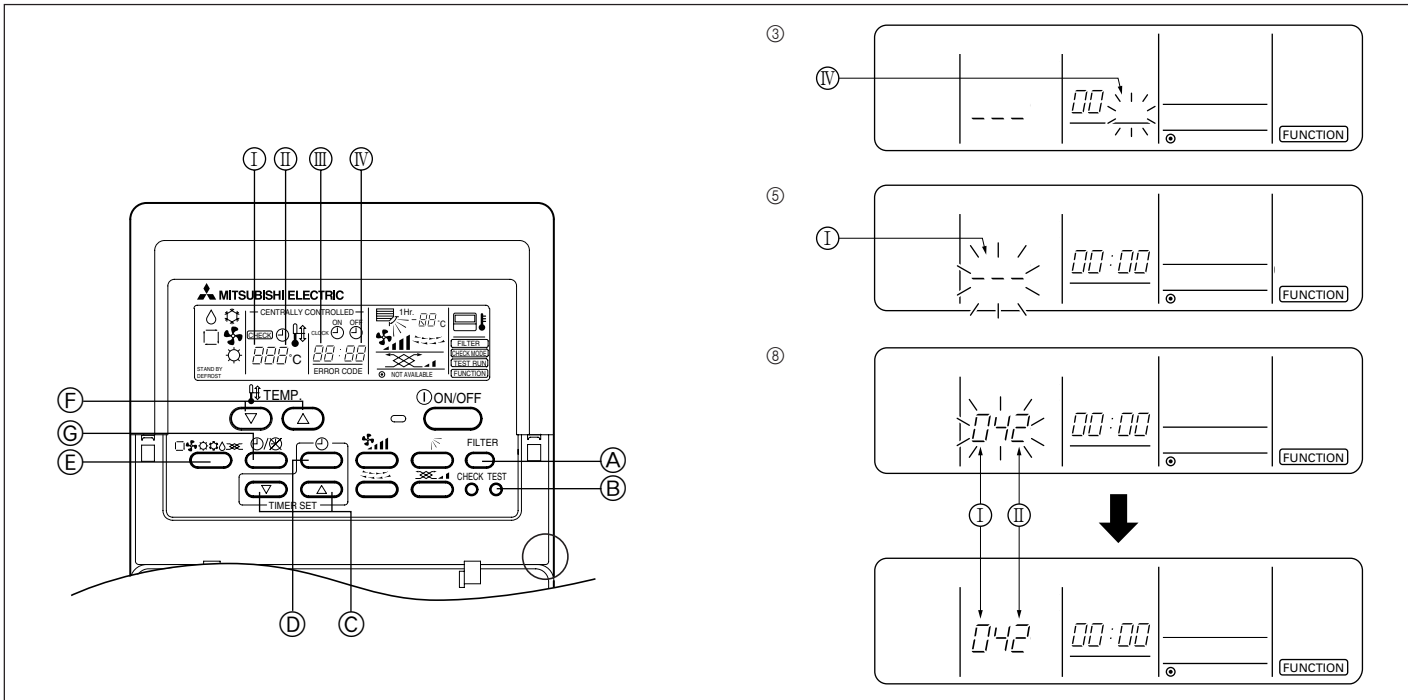

Fig. 7-10

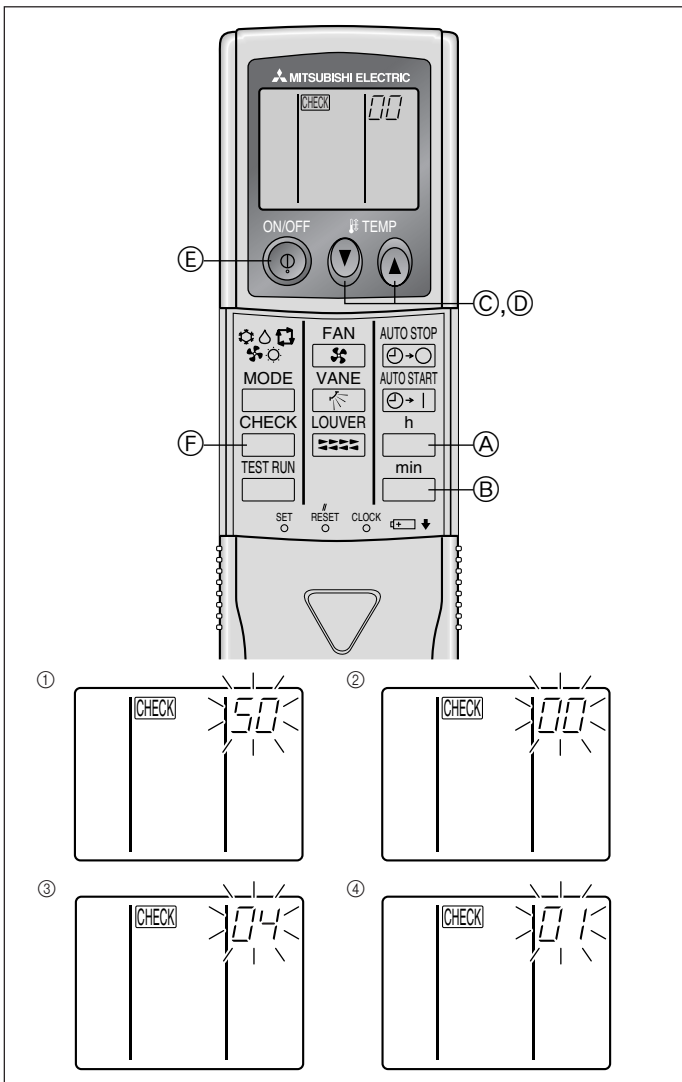

Fig. 7-11

8

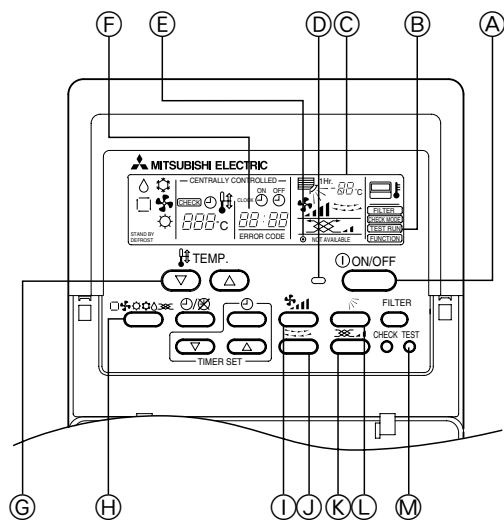

Fig. 8-1

8



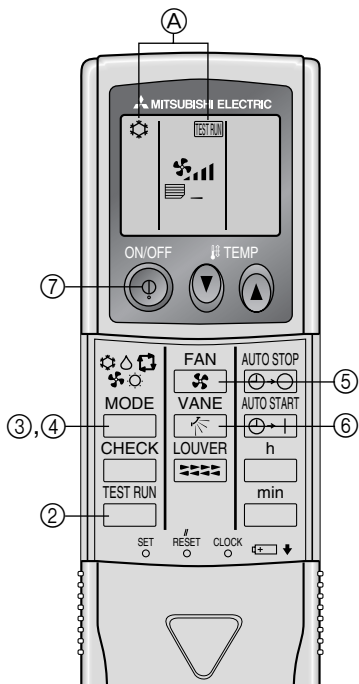

Fig. 8-2

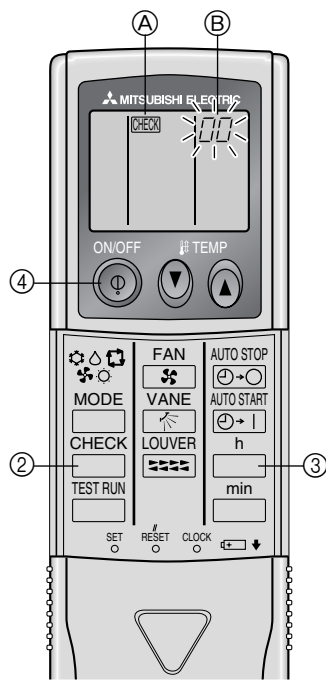

Fig. 8-4

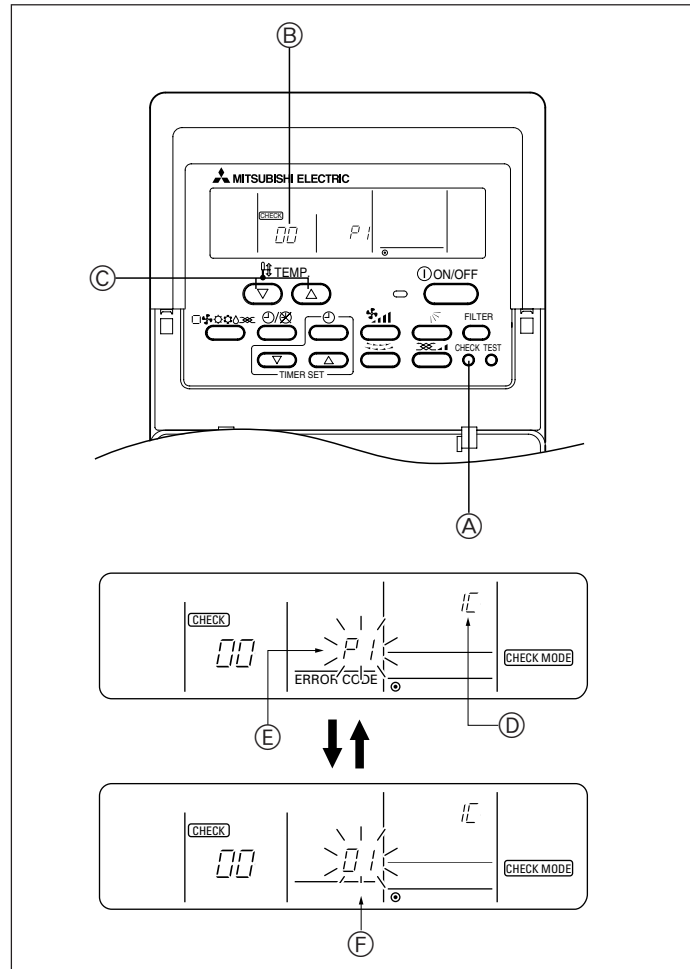

Fig. 8-3

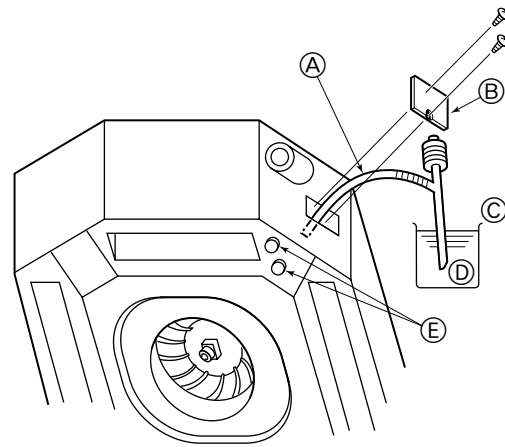

Fig. 8-5

(mm)

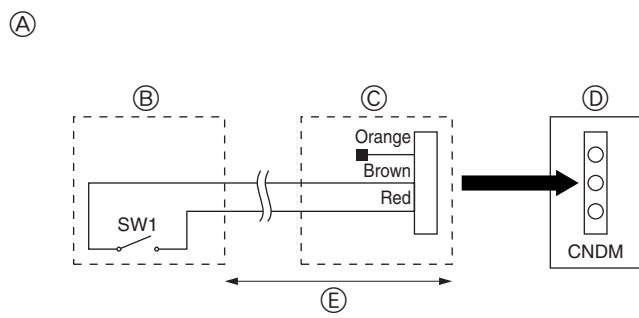
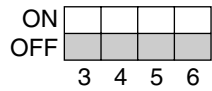

Fig. 9-1



10

Ⓔ SW 1-3~6



Ⓕ SW 1-3~6

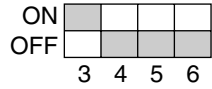

Ⓖ SW 1-3~6

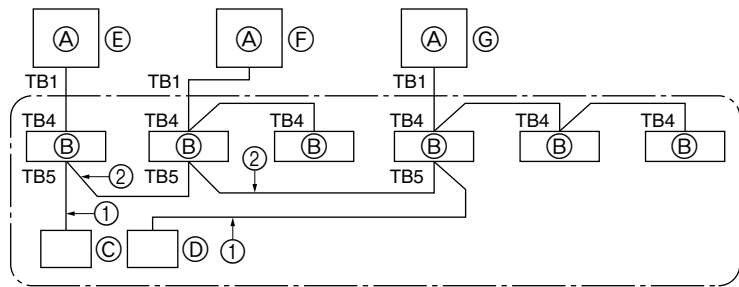
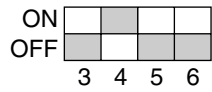

11

(mm)

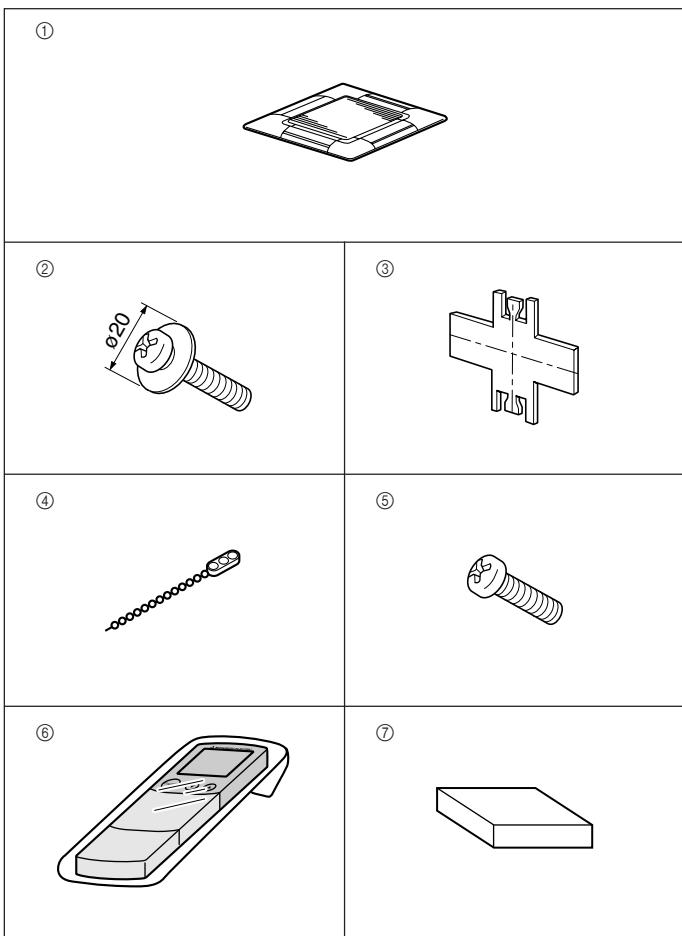

Fig. 11-1

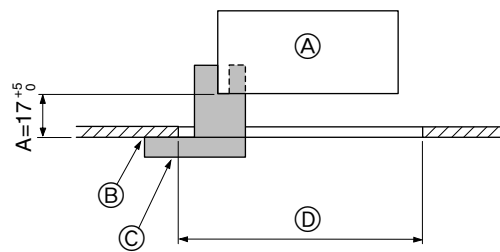

Fig. 11-2

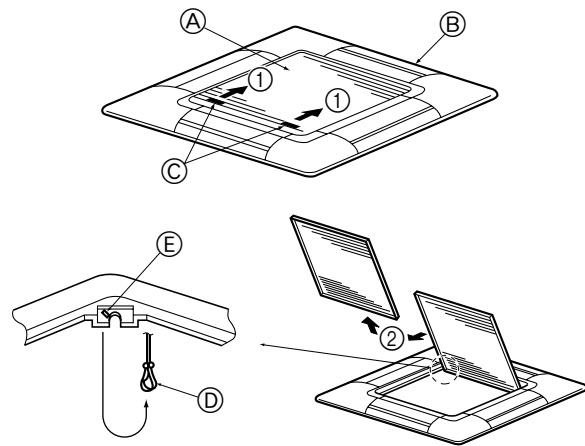

Fig. 11-3

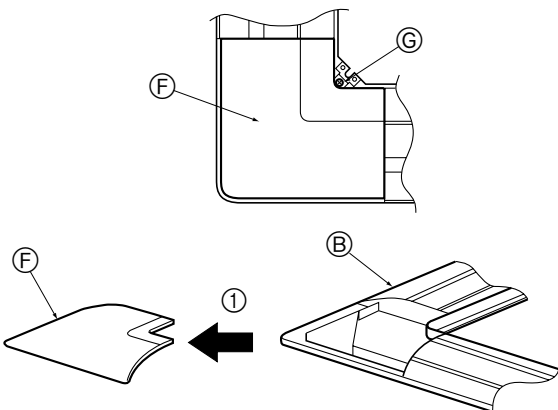

Fig. 11-4

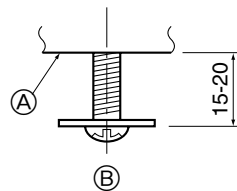

Fig. 11-5

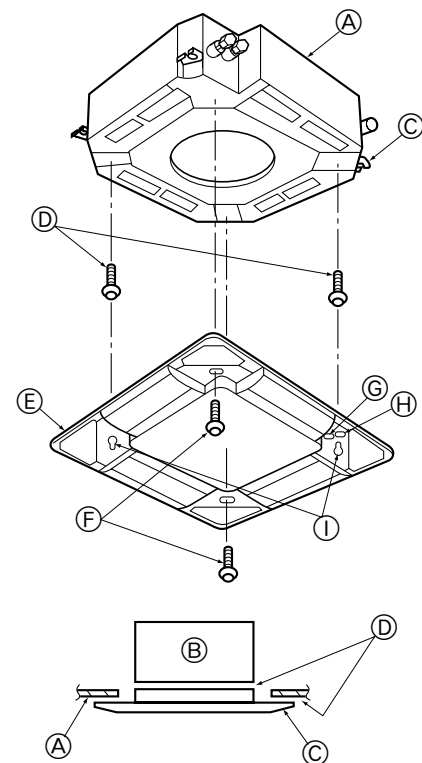

Fig. 11-6

10

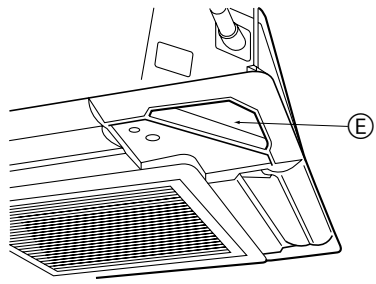

Fig. 11-7

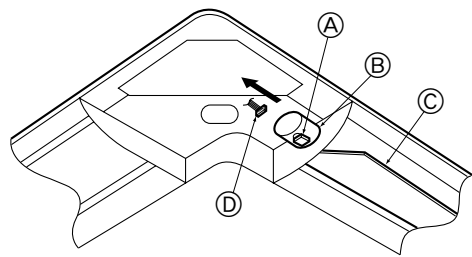

Fig. 11-8

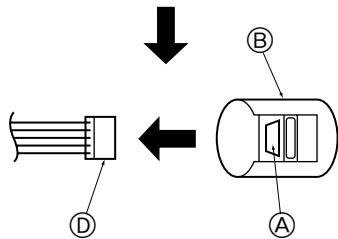
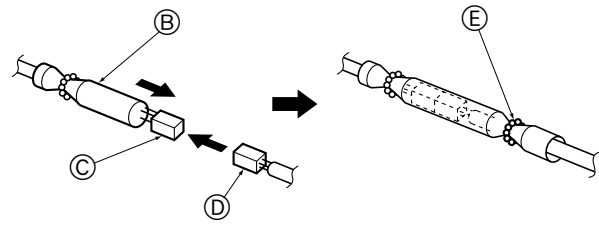

Fig. 11-9

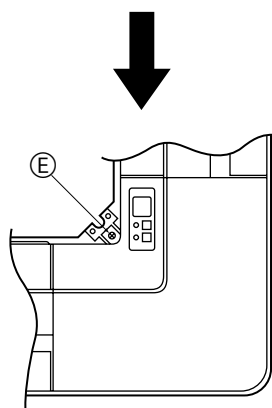
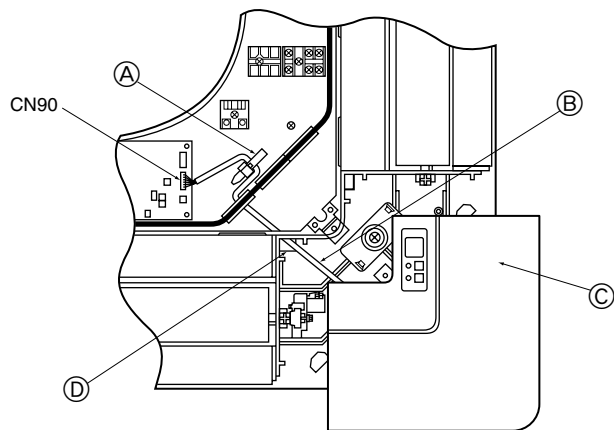

Fig. 11-10

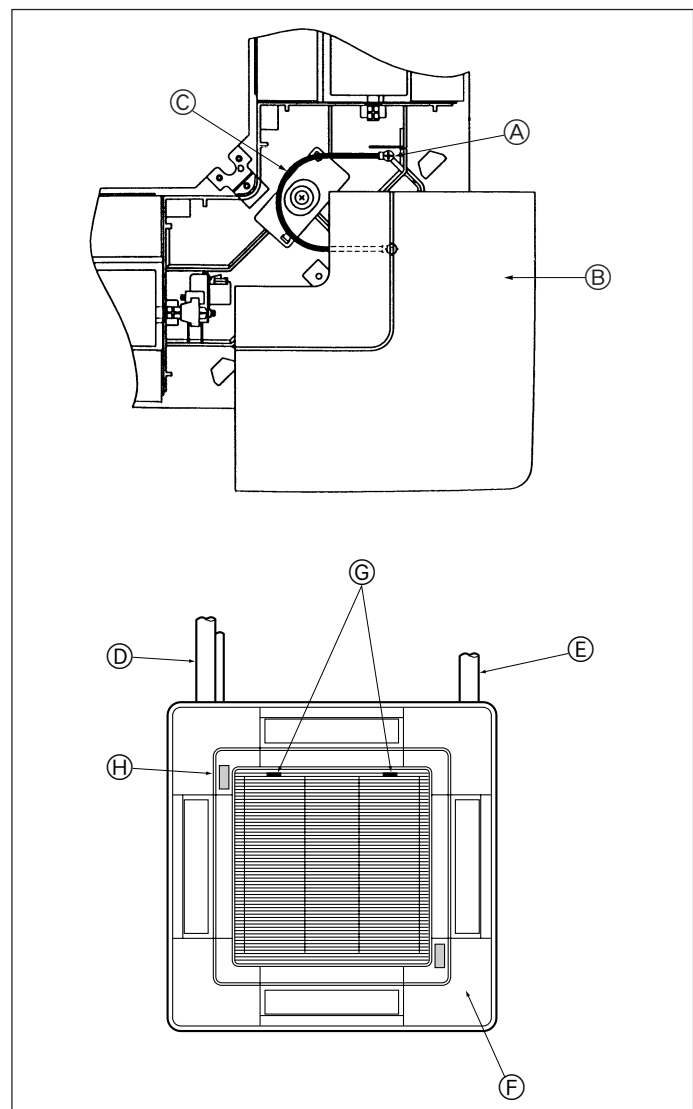

Fig. 11-11



 **mitsubishi electric corporation**
HEAD OFFICE: MITSUBISHI DENKI BLDG., 2-2-3, MARUNOUCHI, CHIYODA-KU, TOKYO 100-8310, JAPAN

BG79U015K01

