

TECHNICAL & SERVICE MANUAL

Series PLA Ceiling Cassettes R407C/R410A

**Indoor unit
[Model names]**

PLA-RP1.6AA

PLA-RP2AA

PLA-RP2.5AA

PLA-RP3AA

PLA-RP4AA

PLA-RP5AA

PLA-RP6AA

[Service Ref.]
PLA-RP1.6AA.UK
PLA-RP2AA.UK
PLA-RP2.5AA.UK
PLA-RP3AA.UK
PLA-RP3AA₁.UK
PLA-RP4AA.UK
PLA-RP4AA₁.UK
PLA-RP5AA.UK
PLA-RP5AA₁.UK
PLA-RP6AA.UK
PLA-RP6AA₁.UK
Revision:

- "12. PARTS LIST" has been modified.

Note:

- This manual does not cover outdoor units. When serving them, please refer to the service manual No.OC294 REVISED EDITION-D, OC261REVISED EDITION-D and this manual in a set.

- Please void OC297 REVISED EDITION-D.

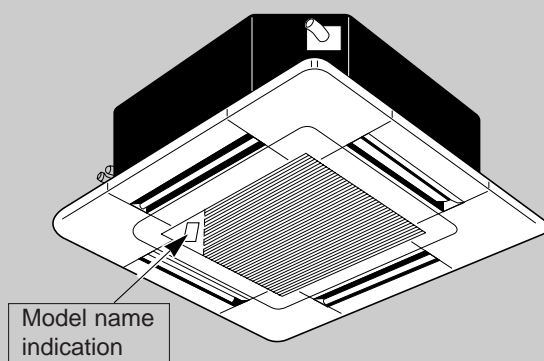
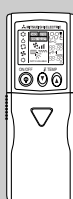
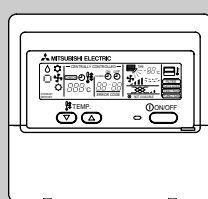
INDOOR UNIT

**WIRELESS REMOTE
CONTROLLER**

**WIRED REMOTE
CONTROLLER**
CONTENTS

1. TECHNICAL CHANGES	2
2. COMBINATION OF INDOOR AND OUTDOOR UNITS...	3
3. SAFETY PRECAUTION	4
4. PART NAMES AND FUNCTIONS	8
5. SPECIFICATIONS	11
6. DATA	21
7. OUTLINES AND DIMENSIONS	60
8. WIRING DIAGRAM	61
9. REFRIGERANT SYSTEM DIAGRAM	62
10. TROUBLESHOOTING	63
11. DISASSEMBLY PROCEDURE	74
12. PARTS LIST	77
13. OPTIONAL PARTS	84

Revision:

“ 12. PARTS LIST ” has been modified on page 82.

Page	Revise point	Service Ref.	Incorrect	Correct
82	FUNCTIONAL PARTS No.14 CAPACITOR	PLA-RP4AA.UK PLA-RP4AA ₁ .UK	S70 E02 225	S70 E02 255

1 TECHNICAL CHANGES

REVISED EDITION-A

PLA-RP3,4,5,6AA.UK PLA-RP3,4,5,6AA₁.UK

1. Connectable outdoor unit has changed.

● OC297 (PLA-RP•AA.UK)

OC294
R410A
PUHZ-RP3VHA
PUHZ-RP4VHA
PUHZ-RP5VHA
PUHZ-RP6VHA



● OC297 REVISED EDITION-A (PLA-RP•AA.UK, AA₁.UK)

OC294	OC261 REVISED EDITION-A	
R410A	R407C	
PUHZ-RP3VHA	PUH-P3VGAA.UK	PU-P3VGAA.UK
	PUH-P3VGAA ₁ .UK	PU-P3VGAA ₁ .UK
	PUH-P3YGAA.UK PUH-P3YGAA ₁ .UK	PU-P3YGAA.UK PU-P3YGAA ₁ .UK
PUHZ-RP4VHA	PUH-P4VGAA.UK	PU-P4VGAA.UK
	PUH-P4VGAA ₁ .UK	PU-P4VGAA ₁ .UK
	PUH-P4YGAA.UK PUH-P4YGAA ₁ .UK	PU-P4YGAA.UK PU-P4YGAA ₁ .UK
PUHZ-RP5VHA	PUH-P5YGAA.UK * PUH-P5YGAA ₁ .UK *	PU-P5YGAA.UK * PU-P5YGAA ₁ .UK *
PUHZ-RP6VHA	PUH-P6YGAA.UK PUH-P6YGAA ₁ .UK	PU-P6YGAA.UK PU-P6YGAA ₁ .UK

* Note: PLA-RP5AA.UK is connected to PUHZ-RP5VHA only.

PLA-RP5AA₁.UK can connect to PUHZ-RP5VHA, PUH-P5YGAA.UK, PUH-P5YGAA₁.UK, PU-P5YGAA.UK and PU-P5YGAA₁.UK.

PLA-RP5AA₁.UK

2. Corresponding to the addition of connectable outdoor unit, the setting of SW2 (Capacity setting) on the indoor controller board have also changed.



REVISED EDITION-B

• PLA-RP1.6AA.UK, PLA-RP2AA.UK and PLA-RP2.5AA.UK are added in REVISED EDITION-B.

2

COMBINATION OF INDOOR AND OUTDOOR UNITS

(R410A Inverter)

Indoor unit	Outdoor unit [OC294 REVISED EDITION-C]						
	Heat pump type						
	PUHZ-RP						
	1.6	2	2.5	3	4	5	6
VHA	VHA	VHA	VHA	VHA	VHA	VHA	
		VHA ₁	VHA ₁	VHA ₁	VHA ₁	VHA ₁	
PLA-RP1.6AA.UK	○	—	—	—	—	—	—
PLA-RP2AA.UK	—	○	—	—	—	—	—
PLA-RP2.5AA.UK	—	—	○	—	—	—	—
PLA-RP3AA.UK	—	—	—	○	—	—	—
PLA-RP3AA ₁ .UK	—	—	—	○	—	—	—
PLA-RP4AA.UK	—	—	—	—	○	—	—
PLA-RP4AA ₁ .UK	—	—	—	—	○	—	—
PLA-RP5AA.UK	—	—	—	—	—	○	—
PLA-RP5AA ₁ .UK	—	—	—	—	—	○	—
PLA-RP6AA.UK	—	—	—	—	—	—	○
PLA-RP6AA ₁ .UK	—	—	—	—	—	—	○

(R407C Fixed speed)

	Indoor unit	Outdoor unit [OC261 REVISED EDITION-B]											
		Heat pump type											
		PUH-P											
		1.6	2	2.5	3	4	5	6					
VGAA.UK	YGAA.UK	VGAA.UK	YGAA.UK	VGAA.UK	YGAA.UK	VGAA.UK	YGAA.UK	VGAA.UK	YGAA.UK	YGAA.UK	YGAA.UK		
VGAA ₁ .UK	YGAA ₁ .UK	VGAA ₁ .UK	YGAA ₁ .UK	VGAA ₁ .UK	YGAA ₁ .UK	VGAA ₁ .UK	YGAA ₁ .UK	VGAA ₁ .UK	YGAA ₁ .UK	YGAA ₁ .UK	YGAA ₁ .UK		
Heat pump without electric heater	PLA-RP1.6AA.UK	○	○	—	—	—	—	—	—	—	—	—	
	PLA-RP2AA.UK	—	—	○	○	—	—	—	—	—	—	—	
	PLA-RP2.5AA.UK	—	—	—	—	○	○	—	—	—	—	—	
	PLA-RP3AA.UK	—	—	—	—	—	—	○	○	—	—	—	
	PLA-RP3AA ₁ .UK	—	—	—	—	—	—	○	○	—	—	—	
	PLA-RP4AA.UK	—	—	—	—	—	—	—	○	○	—	—	
	PLA-RP4AA ₁ .UK	—	—	—	—	—	—	—	○	○	—	—	
	PLA-RP5AA.UK	—	—	—	—	—	—	—	—	—	×	—	
	PLA-RP5AA ₁ .UK	—	—	—	—	—	—	—	—	—	○	—	
	PLA-RP6AA.UK	—	—	—	—	—	—	—	—	—	—	○	
PLA-RP6AA ₁ .UK	—	—	—	—	—	—	—	—	—	—	○		

	Indoor unit	Outdoor unit [OC261 REVISED EDITION-B]											
		Cooling only type											
		PU-P											
		1.6	2	2.5	3	4	5	6					
VGAA.UK	YGAA.UK	VGAA.UK	YGAA.UK	VGAA.UK	YGAA.UK	VGAA.UK	YGAA.UK	VGAA.UK	YGAA.UK	YGAA.UK	YGAA.UK		
VGAA ₁ .UK	YGAA ₁ .UK	VGAA ₁ .UK	YGAA ₁ .UK	VGAA ₁ .UK	YGAA ₁ .UK	VGAA ₁ .UK	YGAA ₁ .UK	VGAA ₁ .UK	YGAA ₁ .UK	YGAA ₁ .UK	YGAA ₁ .UK		
Cooling only	PLA-RP1.6AA.UK	○	○	—	—	—	—	—	—	—	—	—	
	PLA-RP2AA.UK	—	—	○	○	—	—	—	—	—	—	—	
	PLA-RP2.5AA.UK	—	—	—	—	○	○	—	—	—	—	—	
	PLA-RP3AA.UK	—	—	—	—	—	—	○	○	—	—	—	
	PLA-RP3AA ₁ .UK	—	—	—	—	—	—	○	○	—	—	—	
	PLA-RP4AA.UK	—	—	—	—	—	—	—	○	○	—	—	
	PLA-RP4AA ₁ .UK	—	—	—	—	—	—	—	○	○	—	—	
	PLA-RP5AA.UK	—	—	—	—	—	—	—	—	—	×	—	
	PLA-RP5AA ₁ .UK	—	—	—	—	—	—	—	—	—	○	—	
	PLA-RP6AA.UK	—	—	—	—	—	—	—	—	—	—	○	
PLA-RP6AA ₁ .UK	—	—	—	—	—	—	—	—	—	—	○		

CAUTIONS RELATED TO NEW REFRIGERANT

Cautions for units utilizing refrigerant R407C

Do not use the existing refrigerant piping.

The old refrigerant and lubricant in the existing piping contains a large amount of chlorine which may cause the lubricant deterioration of the new unit.

Use liquid refrigerant to charge the system.

If gas refrigerant is used to seal the system, the composition of the refrigerant in the cylinder will change and performance may drop.

Use "low residual oil piping"

If there is a large amount of residual oil (hydraulic oil, etc.) inside the piping and joints, deterioration of the lubricant will result.

Do not use a refrigerant other than R407C.

If another refrigerant (R22, etc.) is used, the chlorine in the refrigerant may cause the lubricant deterioration.

**Store the piping to be used during installation indoors with keep both ends sealed until just before brazing.
(Store elbows and other joints in a plastic bag.)**

If dust, dirt, or water enters the refrigerant cycle, deterioration of the oil and compressor trouble may result.

Use a vacuum pump with a reverse flow check valve.

The vacuum pump oil may flow back into the refrigerant cycle and cause the lubricant deterioration.

Use ESTR, ETHER or HAB as the lubricant to coat flares and flange connection parts.

If large amount of mineral oil enter, that can cause deterioration of refrigerant oil etc.

Ventilate the room if refrigerant leaks during operation. If refrigerant comes into contact with a flame, poisonous gases will be released.**[1] Cautions for service**

- After recovering the all refrigerant in the unit, proceed to working.
- Do not release refrigerant in the air.
- After completing the repair service, recharge the cycle with the specified amount of liquid refrigerant.

[2] Refrigerant recharging**(1) Refrigerant recharging process**

- ①Direct charging from the cylinder.
 - R407C cylinder are available on the market has a syphon pipe.
 - Leave the syphon pipe cylinder standing and recharge it.
 - (By liquid refrigerant)

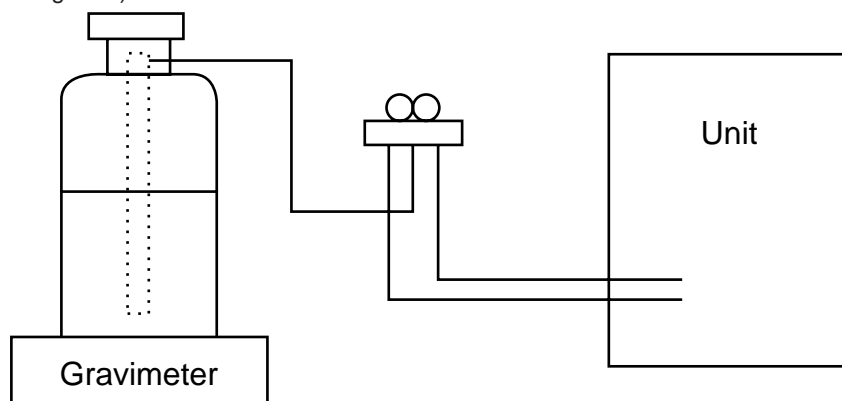
**(2) Recharge in refrigerant leakage case**

- After recovering the all refrigerant in the unit, proceed to working.
- Do not release the refrigerant in the air.
- After completing the repair service, recharge the cycle with the specified amount of liquid refrigerant.

[3] Service tools

Use the below service tools as exclusive tools for R407C refrigerant.

No.	Tool name	Specifications
①	Gauge manifold	·Only for R407C.
		·Use the existing fitting SPECIFICATIONS. (UNF7/16)
		·Use high-tension side pressure of 3.43MPa·G or over.
②	Charge hose	·Only for R407C.
		·Use pressure performance of 5.10MPa·G or over.
③	Electronic scale	
④	Gas leak detector	·Use the detector for R134a or R407C.
⑤	Adapter for reverse flow check.	·Attach on vacuum pump.
⑥	Refrigerant charge base.	
⑦	Refrigerant cylinder.	·For R407C ·Top of cylinder (Brown)
		·Cylinder with syphon
⑧	Refrigerant recovery equipment.	

CAUTIONS RELATED TO NEW REFRIGERANT

Cautions for units utilising refrigerant R410A

Use new refrigerant pipes.

In case of using the existing pipes for R22, be careful with the followings.

- For RP4, 5 and 6, be sure to perform replacement operation before test run.
- Change flare nut to the one provided with this product. Use a newly flared pipe.
- Avoid using thin pipes.

Make sure that the inside and outside of refrigerant piping is clean and it has no contamination such as sulfur hazardous for use, oxides, dirt, shaving particles, etc. In addition, use pipes with specified thickness.

Contamination inside refrigerant piping can cause deterioration of refrigerant oil etc.

Store the piping to be used during installation indoors and keep both ends of the piping sealed until just before brazing. (Leave elbow joints, etc. in their packaging.)

If dirt, dust or moisture enter into refrigerant cycle, that can cause deterioration of refrigerant oil or malfunction of compressor.

Use ester oil, ether oil or alkylbenzene oil (small amount) as the refrigerant oil applied to flares and flange connections.

If large amount of mineral oil enter, that can cause deterioration of refrigerant oil etc.

Charge refrigerant from liquid phase of gas cylinder.

If the refrigerant is charged from gas phase, composition change may occur in refrigerant and the efficiency will be lowered.

Do not use refrigerant other than R410A.

If other refrigerant (R22 etc.) is used, chlorine in refrigerant can cause deterioration of refrigerant oil etc.

Use a vacuum pump with a reverse flow check valve.

Vacuum pump oil may flow back into refrigerant cycle and that can cause deterioration of refrigerant oil etc.

Use the following tools specifically designed for use with R410A refrigerant.

The following tools are necessary to use R410A refrigerant.

Tools for R410A	
Gauge manifold	Flare tool
Charge hose	Size adjustment gauge
Gas leak detector	Vacuum pump adaptor
Torque wrench	Electronic refrigerant charging scale

Keep the tools with care.

If dirt, dust or moisture enter into refrigerant cycle, that can cause deterioration of refrigerant oil or malfunction of compressor.

Do not use a charging cylinder.

If a charging cylinder is used, the composition of refrigerant will change and the efficiency will be lowered.

Ventilate the room if refrigerant leaks during operation. If refrigerant comes into contact with a flame, poisonous gases will be released.

[1] Cautions for service

- (1) Perform service after collecting the refrigerant left in unit completely.
- (2) Do not release refrigerant in the air.
- (3) After completing service, charge the cycle with specified amount of refrigerant.
- (4) When performing service, install a filter drier simultaneously.
Be sure to use a filter drier for new refrigerant.

[2] Additional refrigerant charge

When charging directly from cylinder

- Check that cylinder for R410A on the market is syphon type.
- Charging should be performed with the cylinder of syphon stood vertically. (Refrigerant is charged from liquid phase.)

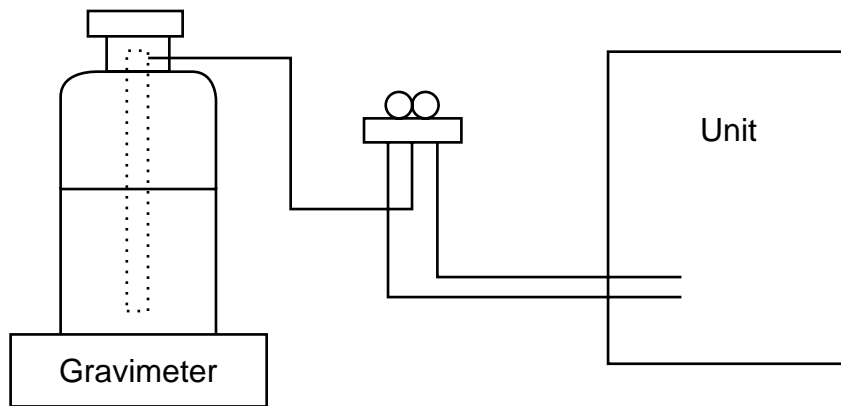

[3] Service tools

Use the below service tools as exclusive tools for R410A refrigerant.

No.		Specifications
①	Gauge manifold	·Only for R410A
		·Use the existing fitting specifications. (UNF1/2)
		·Use high-tension side pressure of 5.3MPa·G or over.
②	Charge hose	·Only for R410A
		·Use pressure performance of 5.09MPa·G or over.
③	Electronic scale	—
④	Gas leak detector	·Use the detector for R134a, R407C or R410A.
⑤	Adaptor for reverse flow check	·Attach on vacuum pump.
⑥	Refrigerant charge base	—
⑦	Refrigerant cylinder	·Only for R410A Top of cylinder (Pink)
		Cylinder with syphon
⑧	Refrigerant recovery equipment	—

4

PART NAMES AND FUNCTIONS

● Indoor Unit

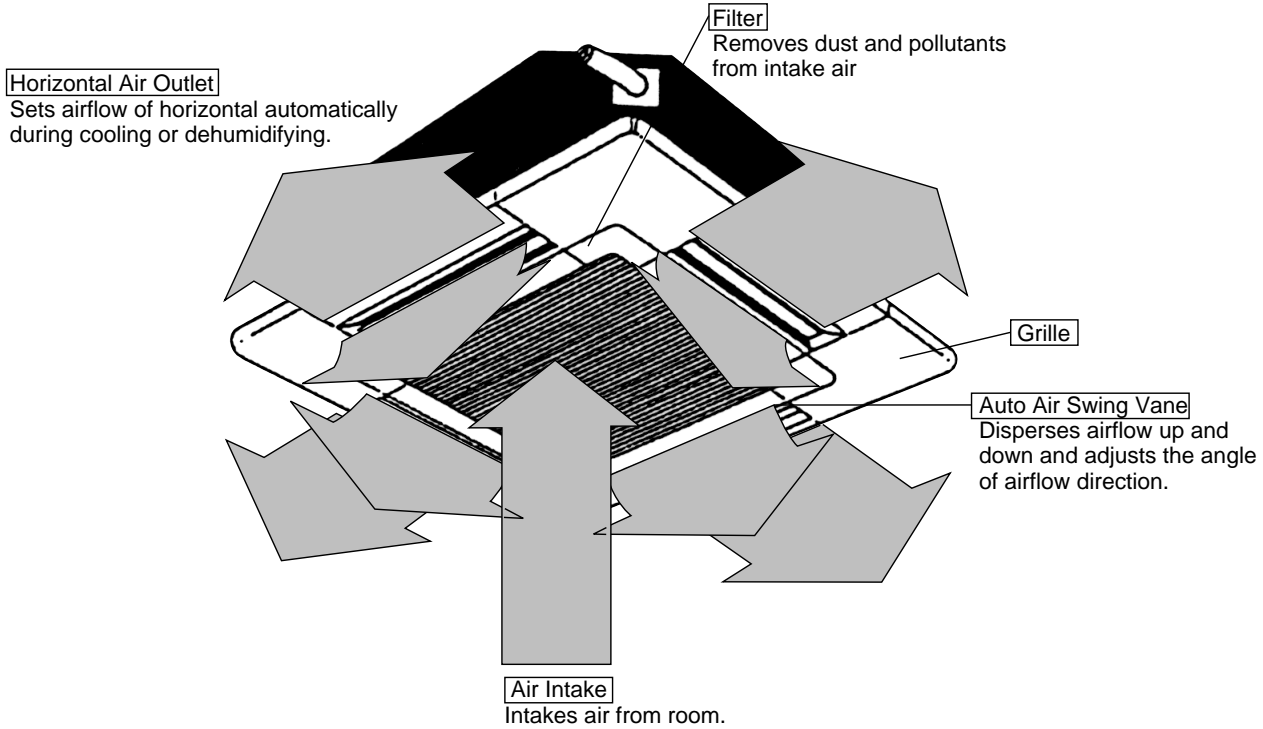

● Wired remote controller

On the controls are set, the same operation mode can be repeated by simply pressing the ON/OFF button.

● Operation buttons

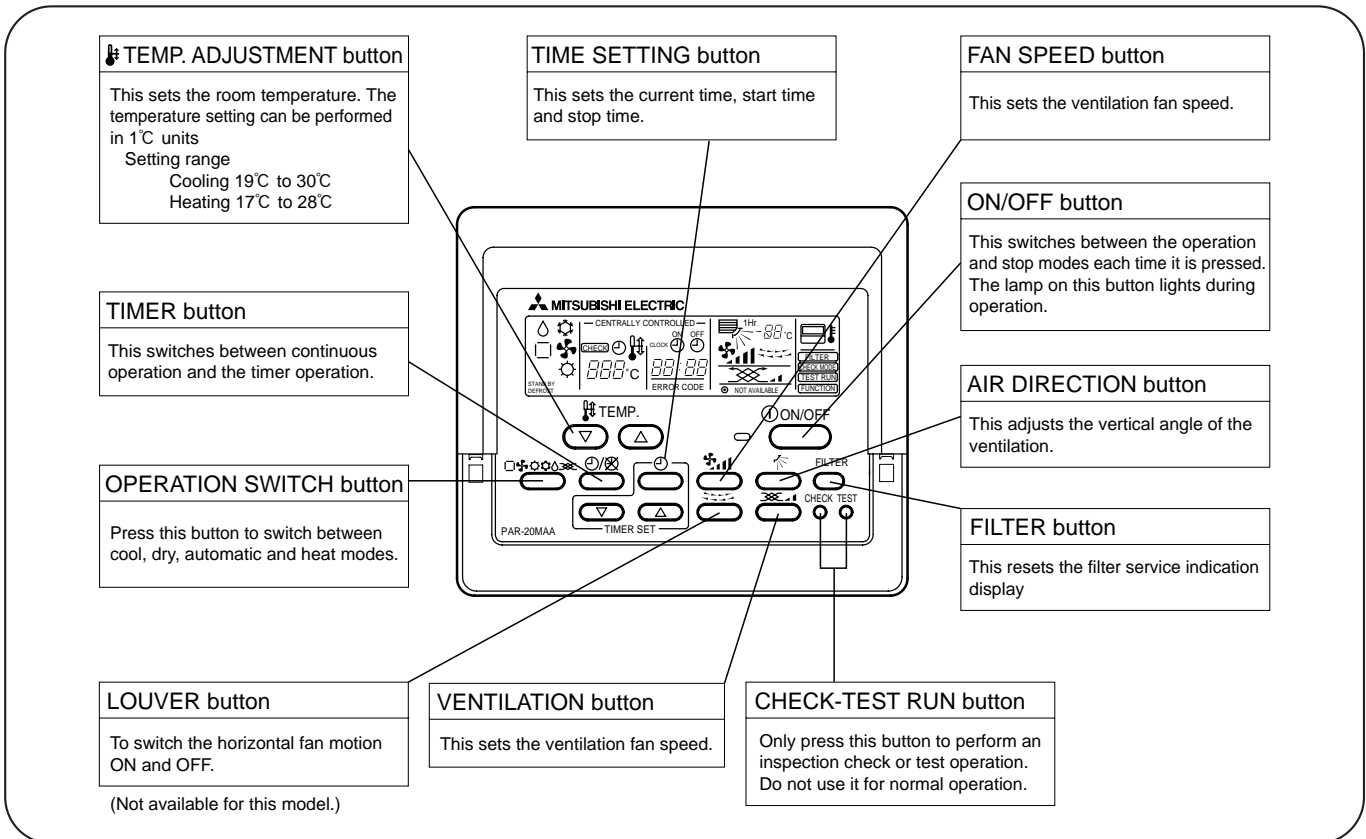

● Display

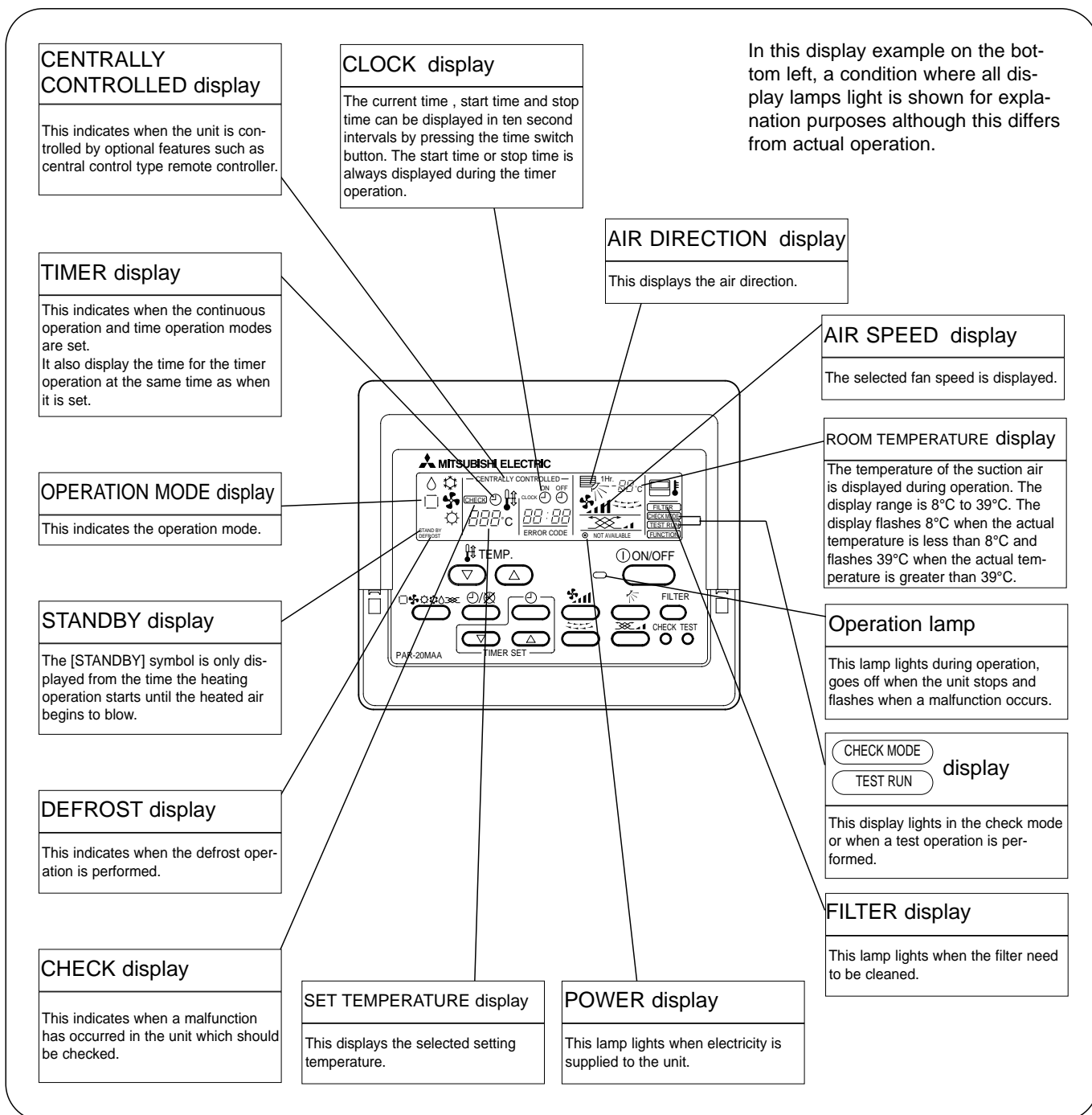

Caution

- Only the Power display lights when the unit is stopped and power supplied to the unit.
- When the central control remote control unit, which is sold separately, is used the ON-OFF button, operation switch button and TEMP. adjustment button do not operate.
- "NOT AVAILABLE" is displayed when the Air speed button is pressed. This indicates that this room unit is not equipped with the fan direction adjustment function and the louver function.
- When power is turned ON for the first time, it is normal that "H0" is displayed on the room temperature indication (For max. 2minutes). Please wait until this "H0" indication disappears then start the operation.

● Wireless remote controller

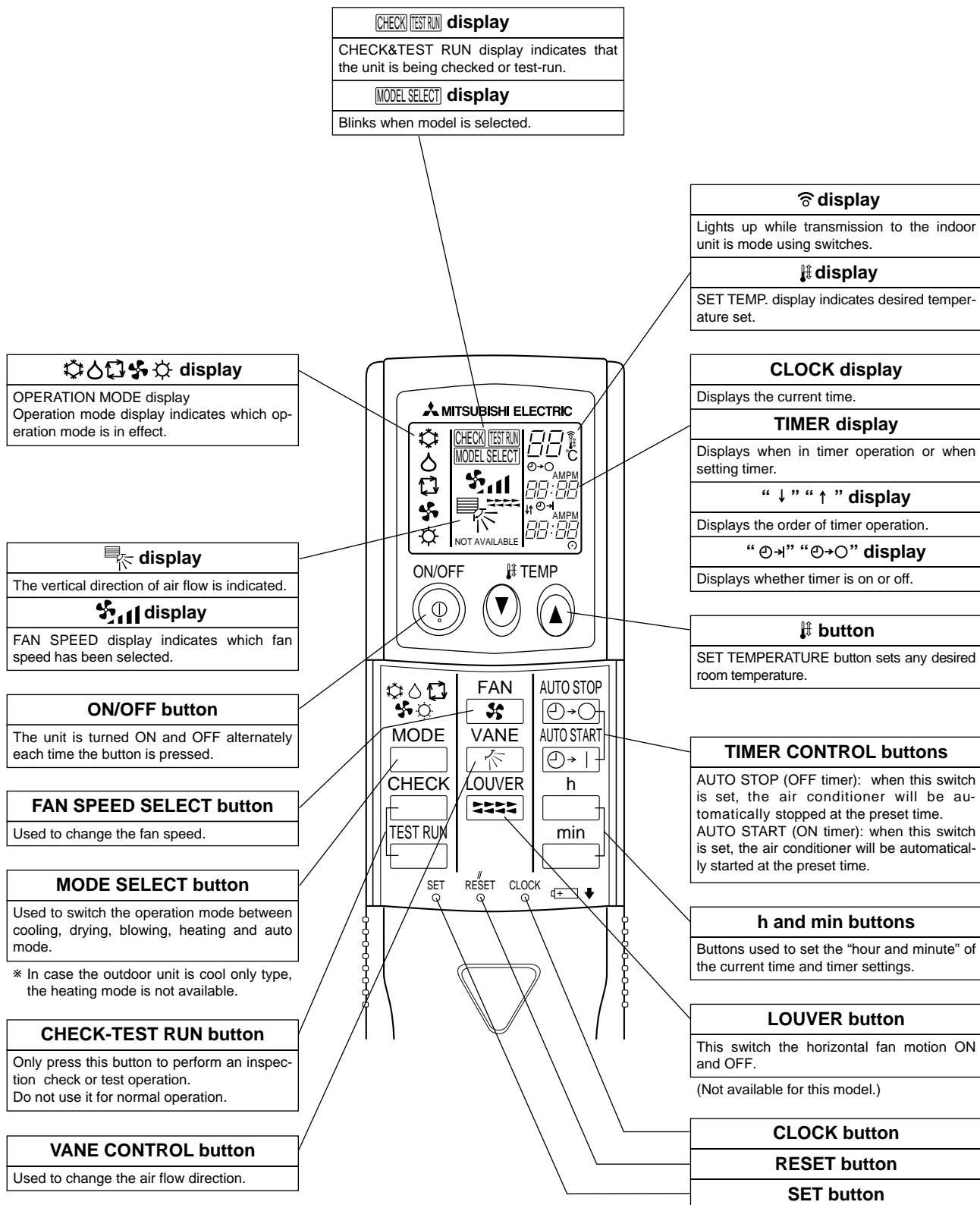

5

SPECIFICATIONS

Heat pump type (1)

Item		Service Ref.	PLA-RP1.6AA.UK			
Function			Cooling	Heating		
Capacity		Btu/h	12,300	14,000		
		W	3,600(1,600~4,500)	4,100(1,600~5,200)		
Total input		kW	1.07	1.12		
Indoor unit	Service Ref.		PLA-RP1.6AA.UK			
	Power supply (phase, cycle, voltage)		Single phase, 50Hz, 220-230-240V			
	Input		kW	0.16	0.16	
	Running current		A	0.79	0.79	
	Starting current		A	1.0	1.0	
	External finish (Panel)		Munsell 0.70Y 8.59/0.97			
	Heat exchanger		Plate fin coil			
	Fan	Fan (drive) × No.		Turbo fan (direct) ×1		
		Fan motor output		kW		0.070
		Airflow (Low-Medium2-Medium1-High)		m ³ / min (CFM)		11-12-13-14(390-425-460-495)
		External static pressure		Pa (mmAq)		0 (direct blow)
	Booster heater		kW		—	
	Operation control & Thermostat		Remote controller & built-in			
	Sound level (Low-Medium2-Medium1-High)		dB		27-28-29-31	
	Unit drain pipe I.D.		mm (in.)		32 (1-1/4)	
Dimensions	W	mm (in.)	UNIT : 840 (33-1/16)	PANEL : 950 (37-3/8)		
	D	mm (in.)	UNIT : 840 (33-1/16)	PANEL : 950 (37-3/8)		
	H	mm (in.)	UNIT : 258 (10-3/16)	PANEL : 30 (1-3/16)		
Weight		kg (lbs.)		UNIT : 24 (53) PANEL : 5 (11)		
Outdoor unit Service Ref.		PUHZ-RP1.6VHA				

Item		Service Ref.	PLA-RP2AA.UK			
Function			Cooling	Heating		
Capacity		Btu/h	17,100	20,500		
		W	5,000(2,300~5,600)	6,000(2,500~7,300)		
Total input		kW	1.55	1.62		
Indoor unit	Service Ref.		PLA-RP2AA.UK			
	Power supply (phase, cycle, voltage)		Single phase, 50Hz, 220-230-240V			
	Input		kW	0.16	0.16	
	Running current		A	0.79	0.79	
	Starting current		A	1.0	1.0	
	External finish (Panel)		Munsell 0.70Y 8.59/0.97			
	Heat exchanger		Plate fin coil			
	Fan	Fan (drive) × No.		Turbo fan (direct) ×1		
		Fan motor output		kW		0.070
		Airflow (Low-Medium2-Medium1-High)		m ³ / min (CFM)		14-15-16-18(495-530-565-635)
		External static pressure		Pa (mmAq)		0 (direct blow)
	Booster heater		kW		—	
	Operation control & Thermostat		Remote controller & built-in			
	Sound level (Low-Medium2-Medium1-High)		dB		28-29-31-33	
	Unit drain pipe I.D.		mm (in.)		32 (1-1/4)	
Dimensions	W	mm (in.)	UNIT : 840 (33-1/16)	PANEL : 950 (37-3/8)		
	D	mm (in.)	UNIT : 840 (33-1/16)	PANEL : 950 (37-3/8)		
	H	mm (in.)	UNIT : 258 (10-3/16)	PANEL : 30 (1-3/16)		
Weight		kg (lbs.)		UNIT : 24(53) PANEL : 5 (11)		
Outdoor unit Service Ref.		PUHZ-RP2VHA				

NOTE:

- Rating conditions (ISO T1)
 Cooling Indoor : D.B. 27°C (80°F) W.B. 19°C (66°F) Outdoor : D.B. 35°C (95°F) W.B. 24°C (75°F)
 Heating Indoor : D.B. 20°C (68°F) Outdoor : D.B. 7°C (45°F) W.B. 6°C (43°F)
 Refrigerant piping length (one way) : 5m (16ft.)
- Guaranteed operating range

		Indoor	Outdoor
Cooling	Upper limit	D.B. 35°C, W.B. 22.5°C	D.B. 46°C
	Lower limit	D.B. 19°C, W.B. 15°C	D.B. -5°C
Heating	Upper limit	D.B. 28°C	D.B. 21°C, W.B. 15°C
	Lower limit	D.B. 17°C	D.B. -11°C, W.B. -12°C

- Guaranteed voltage
198-264V, 50Hz

- Above data based on indicated voltage
 Indoor unit Single phase 230V 50Hz
 Outdoor unit Single phase 230V 50Hz

- Refer to the service manual of outdoor unit for the outdoor unit's specifications.

Item		Service Ref.	PLA-RP2.5AA.UK		
Function			Cooling	Heating	
Capacity		Btu/h	20,500	23,900	
		W	6,000 (2,700~6,700)	7,000 (2,800~8,200)	
Total input		kW	1.65	1.85	
Indoor unit	Service Ref.		PLA-RP2.5AA.UK		
	Power supply (phase, cycle, voltage)		Single phase, 50Hz, 220-230-240V		
	Input		kW	0.16	0.16
	Running current		A	0.79	0.79
	Starting current		A	1.0	1.0
	External finish (Panel)		Munsell 0.70Y 8.59/0.97		
	Heat exchanger		Plate fin coil		
	Fan (drive) × No.		Turbo fan (direct) ×1		
	Fan motor output		kW	0.070	
	Airflow (Low-Medium2-Medium1-High)		m ³ / min (CFM)	14-15-16-18(495-530-565-635)	
	External static pressure		Pa (mmAq)	0 (direct blow)	
	Booster heater		kW	—	
	Operation control & Thermostat		Remote controller & built-in		
	Sound level (Low-Medium2-Medium1-High)		dB	28-29-31-33	
	Unit drain pipe I.D.		mm (in.)	32 (1-1/4)	
Dimensions		W	mm (in.)	UNIT : 840 (33-1/16) PANEL : 950 (37-3/8)	
		D	mm (in.)	UNIT : 840 (33-1/16) PANEL : 950 (37-3/8)	
		H	mm (in.)	UNIT : 258 (10-3/16) PANEL : 30 (1-3/16)	
Weight		kg (lbs.)	UNIT : 24 (53)	PANEL : 5 (11)	
Outdoor unit Service Ref.		PUHZ-RP2.5VHA		PUHZ-RP2.5VHA₁	

Item		Service Ref.	PLA-RP3AA.UK PLA-RP3AA ₁ .UK		
Function			Cooling	Heating	
Capacity		Btu/h	24,200	27,300	
		W	7,100 (3,300~8,100)	8,000 (3,500~10,200)	
Total input		kW	1.97	2.34	
Indoor unit	Service Ref.		PLA-RP3AA.UK PLA-RP3AA₁.UK		
	Power supply (phase, cycle, voltage)		Single phase, 50Hz, 220-230-240V		
	Input		kW	0.16	0.16
	Running current		A	0.79	0.79
	Starting current		A	1.0	1.0
	External finish (Panel)		Munsell 0.70Y 8.59/0.97		
	Heat exchanger		Plate fin coil		
	Fan (drive) × No.		Turbo fan (direct) ×1		
	Fan motor output		kW	0.070	
	Airflow (Low-Medium2-Medium1-High)		m ³ / min (CFM)	15-16-18-20 (530-565-635-705)	
	External static pressure		Pa (mmAq)	0 (direct blow)	
	Booster heater		kW	—	
	Operation control & Thermostat		Remote controller & built-in		
	Sound level (Low-Medium2-Medium1-High)		dB	28-30-32-34	
	Unit drain pipe I.D.		mm (in.)	32 (1-1/4)	
Dimensions		W	mm (in.)	UNIT : 840 (33-1/16) PANEL : 950 (37-3/8)	
		D	mm (in.)	UNIT : 840 (33-1/16) PANEL : 950 (37-3/8)	
		H	mm (in.)	UNIT : 258 (10-3/16) PANEL : 30 (1-3/16)	
Weight		kg (lbs.)	UNIT : 24 (53)	PANEL : 5 (11)	
Outdoor unit Service Ref.		PUHZ-RP3VHA		PUHZ-RP3VHA₁	

- NOTE:**
- Rating conditions (ISO T1)
Cooling Indoor : D.B. 27°C (80°F) W.B. 19°C (66°F) Outdoor : D.B. 35°C (95°F) W.B. 24°C (75°F)
Heating Indoor : D.B. 20°C (68°F) Outdoor : D.B. 7°C (45°F) W.B. 6°C (43°F)
Refrigerant piping length (one way) : 5m (16ft.)

2. Guaranteed operating range

		Indoor	Outdoor
Cooling	Upper limit	D.B. 35°C, W.B. 22.5°C	D.B. 46°C
	Lower limit	D.B. 19°C, W.B. 15°C	D.B. -5°C
Heating	Upper limit	D.B. 28°C	D.B. 21°C, W.B. 15°C
	Lower limit	D.B. 17°C	D.B. -11°C, W.B. -12°C

3. Guaranteed voltage
198~264V, 50Hz

4. Above data based on indicated voltage
Indoor unit Single phase 230V 50Hz
Outdoor unit Single phase 230V 50Hz

5. Refer to the service manual of outdoor unit for the outdoor unit's specifications.



Item		Service Ref.	PLA-RP4AA.UK PLA-RP4AA1.UK		
Function			Cooling	Heating	
		Btu/h	34,100	38,200	
Capacity	PUHZ-RP4VHA	W	10,000 (5,000~11,400)	11,200 (5,600~14,000)	
	PUHZ-RP4VHA1	W	10,000 (4,900~11,400)	11,200 (4,500~14,000)	
Total input		kW	3.03	3.39	
Indoor unit	Service Ref.		PLA-RP4AA.UK PLA-RP4AA1.UK		
	Power supply (phase, cycle, voltage)		Single phase, 50Hz, 220-230-240V		
		Input	kW	0.25	0.25
		Running current	A	1.25	1.25
		Starting current	A	2.0	2.0
	External finish (Panel)		Munsell 0.70Y 8.59/0.97		
	Heat exchanger		Plate fin coil		
	Fan	Fan (drive) × No.		Turbo fan (direct) ×1	
			Fan motor output	kW	0.120
			Airflow (Low-Medium2-Medium1-High)	m ³ / min (CFM)	20-23-26-28 (705-810-920-990)
			External static pressure	Pa (mmAq)	0 (direct blow)
	Booster heater		kW	—	
	Operation control & Thermostat		Remote controller & built-in		
	Sound level (Low-Medium2-Medium1-High)		dB		33-36-39-41
	Unit drain pipe I.D.		mm (in.)		32 (1-1/4)
Dimensions	W	mm (in.)	UNIT : 840 (33-1/16) PANEL : 950 (37-3/8)		
	D	mm (in.)	UNIT : 840 (33-1/16) PANEL : 950 (37-3/8)		
	H	mm (in.)	UNIT : 298 (11-3/4) PANEL : 30 (1-3/16)		
Weight		kg (lbs.)	UNIT : 30 (66)	PANEL : 5 (11)	
Outdoor unit Service Ref.		PUHZ-RP4VHA PUHZ-RP4VHA1			

Item		Service Ref.	PLA-RP5AA.UK PLA-RP5AA1.UK		
Function			Cooling	Heating	
		Btu/h	42,700	47,800	
Capacity	PUHZ-RP5VHA	W	12,500 (6,000~14,000)	14,000 (6,000~16,000)	
	PUHZ-RP5VHA1	W	12,500 (5,500~14,000)	14,000 (5,000~16,000)	
Total input		kW	3.89	4.27	
Indoor unit	Service Ref.		PLA-RP5AA.UK PLA-RP5AA1.UK		
	Power supply (phase, cycle, voltage)		Single phase, 50Hz, 220-230-240V		
		Input	kW	0.33	0.33
		Running current	A	1.64	1.64
		Starting current	A	2.0	2.0
	External finish (Panel)		Munsell 0.70Y 8.59/0.97		
	Heat exchanger		Plate fin coil		
	Fan	Fan (drive) × No.		Turbo fan (direct) ×1	
			Fan motor output	kW	0.120
			Airflow (Low-Medium2-Medium1-High)	m ³ / min (CFM)	22-25-28-30 (775-880-990-1,060)
			External static pressure	Pa (mmAq)	0 (direct blow)
	Booster heater		kW	—	
	Operation control & Thermostat		Remote controller & built-in		
	Sound level (Low-Medium2-Medium1-High)		dB		37-40-43-45
	Unit drain pipe I.D.		mm (in.)		32 (1-1/4)
Dimensions	W	mm (in.)	UNIT : 840 (33-1/16) PANEL : 950 (37-3/8)		
	D	mm (in.)	UNIT : 840 (33-1/16) PANEL : 950 (37-3/8)		
	H	mm (in.)	UNIT : 298 (11-3/4) PANEL : 30 (1-3/16)		
Weight		kg (lbs.)	UNIT : 32 (71)	PANEL : 5 (11)	
Outdoor unit Service Ref.		PUHZ-RP5VHA PUHZ-RP5VHA1			

NOTE: 1. Rating conditions (ISO T1)
Cooling Indoor : D.B. 27°C (80°F) W.B. 19°C (66°F) Outdoor : D.B. 35°C (95°F) W.B. 24°C (75°F)
Heating Indoor : D.B. 20°C (68°F) Outdoor : D.B. 7°C (45°F) W.B. 6°C (43°F)
Refrigerant piping length (one way) : 5m (16ft.)

2. Guaranteed operating range

		Indoor	Outdoor
Cooling	Upper limit	D.B. 35°C, W.B. 22.5°C	D.B. 46°C
	Lower limit	D.B. 19°C, W.B. 15°C	D.B. -5°C
Heating	Upper limit	D.B. 28°C	D.B. 21°C, W.B. 15°C
	Lower limit	D.B. 17°C	D.B. -11°C, W.B. -12°C

4. Above data based on indicated voltage
Indoor unit Single phase 230V 50Hz
Outdoor unit Single phase 230V 50Hz

5. Refer to the service manual of outdoor unit for the outdoor unit's specifications.

3. Guaranteed voltage
198~264V, 50Hz



Item		Service Ref.	PLA-RP6AA.UK PLA-RP6AA1.UK		
Function			Cooling	Heating	
		Btu/h	47,800	54,600	
Capacity	PUHZ-RP6VHA	W	14,000 (6,200~15,300)	16,000 (6,200~18,000)	
	PUHZ-RP6VHA1	W	14,000 (5,500~15,300)	16,000 (5,000~18,000)	
Total input		kW	4.99	4.91	
Indoor unit	Service Ref.		PLA-RP6AA.UK PLA-RP6AA1.UK		
	Power supply (phase, cycle, voltage)		Single phase, 50Hz, 220-230-240V		
		Input	kW	0.33	0.33
		Running current	A	1.64	1.64
		Starting current	A	2.0	2.0
	External finish (Panel)		Munsell 0.70Y 8.59/0.97		
	Heat exchanger		Plate fin coil		
	Fan	Fan (drive) × No.		Turbo fan (direct) ×1	
			Fan motor output	kW	0.120
			Airflow (Low-Medium2-Medium1-High)	m ³ / min (CFM)	22-25-28-30 (775-880-990-1,060)
			External static pressure	Pa (mmAq)	0 (direct blow)
	Booster heater		kW	—	
	Operation control & Thermostat		Remote controller & built-in		
	Sound level (Low-Medium2-Medium1-High)		dB	37-40-43-45	
	Unit drain pipe I.D.		mm (in.)	32 (1-1/4)	
	Dimensions	W	mm (in.)	UNIT : 840 (33-1/16) PANEL : 950 (37-3/8)	
D		mm (in.)	UNIT : 840 (33-1/16) PANEL : 950 (37-3/8)		
H		mm (in.)	UNIT : 298 (11-3/4) PANEL : 30 (1-3/16)		
Weight		kg (lbs.)	UNIT : 32 (71)	PANEL : 5 (11)	
Outdoor unit Service Ref.		PUHZ-RP6VHA PUHZ-RP6VHA1			

- NOTE:** 1. Rating conditions (ISO T1)
Cooling : Indoor: D.B. 27°C (80°F) W.B. 19°C (66°F) Outdoor: D.B. 35°C (95°F) W.B. 24°C (75°F)
Heating : Indoor: D.B. 20°C (68°F) Outdoor: D.B. 7°C (45°F) W.B. 6°C (43°F)
Refrigerant piping length (one way) : 5m (16ft.)

2. Guaranteed operating range

		Indoor	Outdoor
Cooling	Upper limit	D.B. 35°C, W.B. 22.5°C	D.B. 46°C
	Lower limit	D.B. 19 °C, W.B. 15°C	D.B. -5°C
Heating	Upper limit	D.B. 28°C	D.B. 21°C, W.B. 15°C
	Lower limit	D.B. 17°C	D.B. -11°C, W.B. -12°C

3. Guaranteed voltage
198~264V, 50Hz

4. Above data based on indicated voltage
Indoor unit Single phase 230V 50Hz
Outdoor unit Single phase 230V 50Hz

5. Refer to the service manual of outdoor unit for the outdoor unit's specifications.

Heat pump type (2)

Item		Service Ref.	PLA-RP1.6AA.UK		
Function			Cooling	Heating	
Capacity		Btu/h	15,400	16,900	
		W	4,500	4,950	
Total input		kW	1.72	1.70	
Indoor unit	Service Ref.		PLA-RP1.6AA.UK		
	Power supply (phase, cycle, voltage)		Single phase, 50Hz, 220-230-240V		
	Input		kW	0.16	0.16
	Running current		A	0.79	0.79
	Starting current		A	1.0	1.0
	External finish (Panel)		Munsell 0.70Y 8.59/0.97		
	Heat exchanger		Plate fin coil		
	Fan (drive) × No.		Turbo fan (direct) × 1		
	Fan motor output		kW	0.070	
	Airflow (Low-Medium2-Medium1-High)		m ³ / min (CFM)	11-12-13-14(390-425-460-495)	
	External static pressure		Pa (mmAq)	0 (direct blow)	
	Booster heater		kW	—	
	Operation control & Thermostat		Remote controller & built-in		
	Sound level (Low-Medium2-Medium1-High)		dB	27-28-29-31	
	Unit drain pipe I.D.		mm (in.)	32 (1-1/4)	
Dimensions		W	mm (in.)	UNIT : 840 (33-1/16) PANEL : 950 (37-3/8)	
		D	mm (in.)	UNIT : 840 (33-1/16) PANEL : 950 (37-3/8)	
		H	mm (in.)	UNIT : 258 (10-3/16) PANEL : 30 (1-3/16)	
Weight		kg (lbs.)	UNIT : 24 (53)	PANEL : 5 (11)	
Outdoor unit Service Ref.		PUH-P1.6VGAA.UK / PUH-P1.6YGAA.UK PUH-P1.6VGAA₁.UK / PUH-P1.6YGAA₁.UK			

Item		Service Ref.	PLA-RP2AA.UK		
Function			Cooling	Heating	
Capacity		Btu/h	19,100	21,700	
		W	5,600	6,350	
Total input		kW	2.53	2.20	
Indoor unit	Service Ref.		PLA-RP2AA.UK		
	Power supply (phase, cycle, voltage)		Single phase, 50Hz, 220-230-240V		
	Input		kW	0.16	0.16
	Running current		A	0.79	0.79
	Starting current		A	1.0	1.0
	External finish (Panel)		Munsell 0.70Y 8.59/0.97		
	Heat exchanger		Plate fin coil		
	Fan (drive) × No.		Turbo fan (direct) × 1		
	Fan motor output		kW	0.070	
	Airflow (Low-Medium2-Medium1-High)		m ³ / min (CFM)	14-15-16-18(495-530-565-635)	
	External static pressure		Pa (mmAq)	0 (direct blow)	
	Booster heater		kW	—	
	Operation control & Thermostat		Remote controller & built-in		
	Sound level (Low-Medium2-Medium1-High)		dB	28-29-31-33	
	Unit drain pipe I.D.		mm (in.)	32 (1-1/4)	
Dimensions		W	mm (in.)	UNIT : 840 (33-1/16) PANEL : 950 (37-3/8)	
		D	mm (in.)	UNIT : 840 (33-1/16) PANEL : 950 (37-3/8)	
		H	mm (in.)	UNIT : 258 (10-3/16) PANEL : 30 (1-3/16)	
Weight		kg (lbs.)	UNIT : 24 (53)	PANEL : 5 (11)	
Outdoor unit Service Ref.		PUH-P2VGAA.UK / PUH-P2YGAA.UK PUH-P2VGAA₁.UK / PUH-P2YGAA₁.UK			

NOTE:

- Rating conditions (ISO T1)
Cooling Indoor : D.B. 27°C (80°F) W.B. 19°C (66°F) Outdoor : D.B. 35°C (95°F) W.B. 24°C (75°F)
Heating Indoor : D.B. 20°C (68°F) Outdoor : D.B. 7°C (45°F) W.B. 6°C (43°F)
Refrigerant piping length (one way) : 5m (16ft.)

- Guaranteed operating range

		Indoor		Outdoor
Cooling	Upper limit	D.B. 35°C, W.B. 22.5°C	D.B. 46°C	
	Lower limit	D.B. 19°C, W.B. 15°C	D.B. -5°C	
Heating	Upper limit	D.B. 28°C		D.B. 24°C, W.B. 18°C
	Lower limit	D.B. 17°C		D.B. -11°C, W.B. -12°C

- Guaranteed voltage
198~264V, 50Hz

- Above data based on indicated voltage
Indoor unit Single phase 230V 50Hz
Outdoor unit Single phase 230V 50Hz / 3 phase 400V 50Hz

- Refer to the service manual of outdoor unit for the outdoor unit's specifications.

Item		Service Ref.	PLA-RP2.5AA.UK		
Function			Cooling	Heating	
Capacity		Btu/h	22,900	24,900	
		W	6,700	7,300	
Total input		kW	2.57	2.40	
Indoor unit	Service Ref.		PLA-RP2.5AA.UK		
	Power supply (phase, cycle, voltage)		Single phase, 50Hz, 220-230-240V		
	Input	kW	0.16	0.16	
		A	0.79	0.79	
		A	1.0	1.0	
	External finish (Panel)		Munsell 0.70Y 8.59/0.97		
	Heat exchanger		Plate fin coil		
	Fan	Fan (drive) × No.		Turbo fan (direct) × 1	
		Fan motor output		0.070	
		Airflow (Low-Medium2-Medium1-High)		14-15-16-18(495-530-565-635)	
		External static pressure		0 (direct blow)	
	Booster heater		kW		
	Operation control & Thermostat		Remote controller & built-in		
	Sound level (Low-Medium2-Medium1-High)		dB		
	Unit drain pipe I.D.		mm (in.)		
Dimensions	W	mm (in.)	UNIT : 840 (33-1/16) PANEL : 950 (37-3/8)		
	D	mm (in.)	UNIT : 840 (33-1/16) PANEL : 950 (37-3/8)		
	H	mm (in.)	UNIT : 258 (10-3/16) PANEL : 30 (1-3/16)		
Weight		kg (lbs.)	UNIT : 24 (53) PANEL : 5 (11)		
Outdoor unit Service Ref.		PUH-P2.5VGAA.UK / PUH-P2.5YGAA.UK PUH-P2.5VGAA₁.UK / PUH-P2.5YGAA₁.UK			

Item		Service Ref.	PLA-RP3AA.UK PLA-RP3AA ₁ .UK		
Function			Cooling	Heating	
Capacity		Btu/h	26,300	31,400	
		W	7,700	9,200	
Total input		kW	3.42	3.48	
Indoor unit	Service Ref.		PLA-RP3AA.UK PLA-RP3AA₁.UK		
	Power supply (phase, cycle, voltage)		Single phase, 50Hz, 220-230-240V		
	Input	kW	0.16	0.16	
		A	0.79	0.79	
		A	1.0	1.0	
	External finish (Panel)		Munsell 0.70Y 8.59/0.97		
	Heat exchanger		Plate fin coil		
	Fan	Fan (drive) × No.		Turbo fan (direct) × 1	
		Fan motor output		0.070	
		Airflow (Low-Medium2-Medium1-High)		15-16-18-20 (530-565-635-705)	
		External static pressure		0 (direct blow)	
	Booster heater		kW		
	Operation control & Thermostat		Remote controller & built-in		
	Sound level (Low-Medium2-Medium1-High)		dB		
	Unit drain pipe I.D.		mm (in.)		
Dimensions	W	mm (in.)	UNIT : 840 (33-1/16) PANEL : 950 (37-3/8)		
	D	mm (in.)	UNIT : 840 (33-1/16) PANEL : 950 (37-3/8)		
	H	mm (in.)	UNIT : 258 (10-3/16) PANEL : 30 (1-3/16)		
Weight		kg (lbs.)	UNIT : 24 (53) PANEL : 5 (11)		
Outdoor unit Service Ref.		PUH-P3VGAA.UK / PUH-P3YGAA.UK PUH-P3VGAA₁.UK / PUH-P3YGAA₁.UK			

NOTE: 1. Rating conditions (ISO T1)
Cooling Indoor : D.B. 27°C (80°F) W.B. 19°C (66°F) Outdoor : D.B. 35°C (95°F) W.B. 24°C (75°F)
Heating Indoor : D.B. 20°C (68°F) Outdoor : D.B. 7°C (45°F) W.B. 6°C (43°F)
Refrigerant piping length (one way) : 5m (16ft.)

2. Guaranteed operating range

		Indoor		Outdoor
Cooling	Upper limit	D.B. 35°C, W.B. 22.5°C	D.B. 46°C	
	Lower limit	D.B. 19°C, W.B. 15°C	D.B. -5°C	
Heating	Upper limit	D.B. 28°C		D.B. 24°C, W.B. 18°C
	Lower limit	D.B. 17°C		D.B. -11°C, W.B. -12°C

3. Guaranteed voltage
198~264V, 50Hz

4. Above data based on indicated voltage
Indoor unit Single phase 230V 50Hz
Outdoor unit Single phase 230V 50Hz / 3 phase 400V 50Hz

5. Refer to the service manual of outdoor unit for the outdoor unit's specifications.



Item		Service Ref.	PLA-RP4AA.UK PLA-RP4AA1.UK		
Function			Cooling	Heating	
Capacity		Btu/h	32,800	35,800	
		W	9,600	10,500	
Total input		kW	3.68	3.91	
Indoor unit	Service Ref.		PLA-RP4AA.UK PLA-RP4AA1.UK		
	Power supply (phase, cycle, voltage)		Single phase, 50Hz, 220-230-240V		
	Input		kW	0.25	0.25
	Running current		A	1.25	1.25
	Starting current		A	2.0	2.0
	External finish (Panel)		Munsell 0.70Y 8.59/0.97		
	Heat exchanger		Plate fin coil		
	Fan (drive) × No.		Turbo fan (direct) × 1		
	Fan motor output		kW	0.120	
	Airflow (Low-Medium2-Medium1-High)		m ³ / min (CFM)	20-23-26-28 (705-810-920-990)	
	External static pressure		Pa (mmAq)	0 (direct blow)	
	Booster heater		kW	—	
	Operation control & Thermostat		Remote controller & built-in		
	Sound level (Low-Medium2-Medium1-High)		dB	33-36-39-41	
	Unit drain pipe I.D.		mm (in.)	32 (1-1/4)	
Dimensions		W	UNIT : 840 (33-1/16) PANEL : 950 (37-3/8)		
		D	UNIT : 840 (33-1/16) PANEL : 950 (37-3/8)		
		H	UNIT : 298 (11-3/4) PANEL : 30 (1-3/16)		
Weight		kg (lbs.)	UNIT : 30 (66)	PANEL : 5 (11)	
Outdoor unit Service Ref.		PUH-P4VGAA.UK / PUH-P4YGAA.UK PUH-P4VGAA1.UK / PUH-P4YGAA1.UK			

Item		Service Ref.	PLA-RP5AA1.UK		
Function			Cooling	Heating	
Capacity		Btu/h	45,400	53,200	
		W	13,300	15,600	
Total input		kW	5.09	5.54	
Indoor unit	Service Ref.		PLA-RP5AA1.UK		
	Power supply (phase, cycle, voltage)		Single phase, 50Hz, 220-230-240V		
	Input		kW	0.33	0.33
	Running current		A	1.64	1.64
	Starting current		A	2.0	2.0
	External finish (Panel)		Munsell 0.70Y 8.59/0.97		
	Heat exchanger		Plate fin coil		
	Fan (drive) × No.		Turbo fan (direct) × 1		
	Fan motor output		kW	0.120	
	Airflow (Low-Medium2-Medium1-High)		m ³ / min (CFM)	22-25-28-30 (775-880-990-1,060)	
	External static pressure		Pa (mmAq)	0 (direct blow)	
	Booster heater		kW	—	
	Operation control & Thermostat		Remote controller & built-in		
	Sound level (Low-Medium2-Medium1-High)		dB	37-40-43-45	
	Unit drain pipe I.D.		mm (in.)	32 (1-1/4)	
Dimensions		W	UNIT : 840 (33-1/16) PANEL : 950 (37-3/8)		
		D	UNIT : 840 (33-1/16) PANEL : 950 (37-3/8)		
		H	UNIT : 298 (11-3/4) PANEL : 30 (1-3/16)		
Weight		kg (lbs.)	UNIT : 32 (71)	PANEL : 5 (11)	
Outdoor unit Service Ref.		PUH-P5YGAA.UK PUH-P5YGAA1.UK			

- NOTE:**
- Rating conditions (ISO T1)
 Cooling Indoor : D.B. 27°C (80°F) W.B. 19°C (66°F) Outdoor : D.B. 35°C (95°F) W.B. 24°C (75°F)
 Heating Indoor : D.B. 20°C (68°F) Outdoor : D.B. 7°C (45°F) W.B. 6°C (43°F)
 Refrigerant piping length (one way) : 5m (16ft.)
 - Guaranteed operating range

		Indoor	Outdoor
Cooling	Upper limit	D.B. 35°C, W.B. 22.5°C	D.B. 46°C
	Lower limit	D.B. 19°C, W.B. 15°C	D.B. -5°C
Heating	Upper limit	D.B. 28°C	D.B. 24°C, W.B. 18°C
	Lower limit	D.B. 17°C	D.B. -11°C, W.B. -12°C
 - Guaranteed voltage
198-264V, 50Hz
 - Above data based on indicated voltage
 Indoor unit Single phase 230V 50Hz
 Outdoor unit Single phase 230V 50Hz / 3 phase 400V 50Hz
 - Refer to the service manual of outdoor unit for the outdoor unit's specifications.



Item		Service Ref.	PLA-RP6AA.UK PLA-RP6AA1.UK		
Function			Cooling	Heating	
Capacity		Btu/h	48,500	58,000	
		W	14,200	17,000	
Total input		kW	5.90	6.35	
Indoor unit	Service Ref.		PLA-RP6AA.UK PLA-RP6AA1.UK		
	Power supply (phase, cycle, voltage)		Single phase, 50Hz, 220-230-240V		
	Input		kW	0.33	0.33
	Running current		A	1.64	1.64
	Starting current		A	2.0	2.0
	External finish (Panel)		Munsell 0.70Y 8.59/0.97		
	Heat exchanger		Plate fin coil		
	Fan (drive) × No.		Turbo fan (direct) × 1		
	Fan motor output		kW	0.120	
	Airflow (Low-Medium2-Medium1-High)		m ³ / min (CFM)	22-25-28-30 (775-880-990-1,060)	
	External static pressure		Pa (mmAq)	0 (direct blow)	
	Booster heater		kW	—	
	Operation control & Thermostat		Remote controller & built-in		
	Sound level (Low-Medium2-Medium1-High)		dB	37-40-43-45	
	Unit drain pipe I.D.		mm (in.)	32 (1-1/4)	
	Dimensions		W	UNIT : 840 (33-1/16) PANEL : 950 (37-3/8)	
D			UNIT : 840 (33-1/16) PANEL : 950 (37-3/8)		
H			UNIT : 298 (11-3/4) PANEL : 30 (1-3/16)		
Weight		kg (lbs.)	UNIT : 32 (71)	PANEL : 5 (11)	
Outdoor unit Service Ref.		PUH-P6YGAA.UK PUH-P6YGAA1.UK			

- NOTE:**
- Rating conditions (ISO T1)
 Cooling : Indoor: D.B. 27°C (80°F) W.B. 19°C (66°F) Outdoor: D.B. 35°C (95°F) W.B. 24°C (75°F)
 Heating : Indoor: D.B. 20°C (68°F) Outdoor: D.B. 7°C (45°F) W.B. 6°C (43°F)
 Refrigerant piping length (one way) : 5m (16ft.)
 - Guaranteed operating range

		Indoor	Outdoor
Cooling	Upper limit	D.B. 35°C, W.B. 22.5°C	D.B. 46°C
	Lower limit	D.B. 19 °C, W.B. 15°C	D.B. -5°C
Heating	Upper limit	D.B. 28°C	D.B. 24 °C, W.B. 18°C
	Lower limit	D.B. 17°C	D.B. -11°C, W.B. -12°C
 - Guaranteed voltage
198~264V, 50Hz
 - Above data based on indicated voltage
 Indoor unit Single phase 230V 50Hz
 Outdoor unit 3 phase 400V 50Hz
 - Refer to the service manual of outdoor unit for the outdoor unit's specifications.

Cooling only type (3)

Service Ref.			PLA-RP1.6AA.UK	PLA-RP2AA.UK
Item			Cooling	
Function			Cooling	
Capacity		Btu/h	15,400	19,100
		W	4,500	5,600
Total input		kW	1.72	2.53
Indoor unit	Service Ref.		PLA-RP1.6AA.UK	PLA-RP2AA.UK
	Power supply (phase, cycle, voltage)		Single phase, 50Hz, 220-230-240V	
	Input		kW	0.16
	Running current		A	0.79
	Starting current		A	1.0
	External finish (Panel)		Munsell 0.70Y 8.59/0.97	
	Heat exchanger		Plate fin coil	
	Fan (drive) × No.		Turbo fan (direct) × 1	
	Fan motor output		kW	0.070
	Airflow (Low-Medium2-Medium1-High)		m ³ / min (CFM)	11-12-13-14 (390-425-460-495)
	External static pressure		Pa (mmAq)	0 (direct blow)
	Booster heater		kW	—
	Operation control & Thermostat		Remote controller & built-in	
	Sound level (Low-Medium2-Medium1-High)		dB	27-28-29-31
	Unit drain pipe I.D.		mm (in.)	32 (1-1/4)
Dimensions		W	mm (in.)	
		D	mm (in.)	
		H	mm (in.)	
Weight		kg (lbs.)	UNIT : 24 (53), PANEL : 5 (11)	
Outdoor unit Service Ref.			PU-P1.6VGAA.UK / PU-P1.6YGAA.UK PU-P1.6VGAA ₁ .UK / PU-P1.6YGAA ₁ .UK	PU-P2VGAA.UK / PU-P2YGAA.UK PU-P2VGAA ₁ .UK / PU-P2YGAA ₁ .UK

Service Ref.			PLA-RP2.5AA.UK		
Item			Cooling		
Function			Cooling		
Capacity		Btu/h	22,900		
		W	6,700		
Total input		kW	2.57		
Indoor unit	Service Ref.		PLA-RP2.5AA.UK		
	Power supply (phase, cycle, voltage)		Single phase, 50Hz, 220-230-240V		
	Input		kW	0.16	
	Running current		A	0.79	
	Starting current		A	1.0	
	External finish (Panel)		Munsell 0.70Y 8.59/0.97		
	Heat exchanger		Plate fin coil		
	Fan (drive) × No.		Turbo fan (direct) × 1		
	Fan motor output		kW	0.070	
	Airflow (Low-Medium2-Medium1-High)		m ³ / min (CFM)	14-15-16-18 (495-530-565-635)	
	External static pressure		Pa (mmAq)	0 (direct blow)	
	Booster heater		kW	—	
	Operation control & Thermostat		Remote controller & built-in		
	Sound level (Low-Medium2-Medium1-High)		dB	28-29-31-33	
	Unit drain pipe I.D.		mm (in.)	32 (1-1/4)	
Dimensions		W	mm (in.)		
		D	mm (in.)		
		H	mm (in.)		
Weight		kg (lbs.)	UNIT : 24 (53), PANEL : 5 (11)		
Outdoor unit Service Ref.			PU-P2.5VGAA.UK / PU-P2.5YGAA.UK PU-P2.5VGAA ₁ .UK / PU-P2.5YGAA ₁ .UK		

NOTE: 1. Rating conditions (ISO T1)
Cooling : Indoor: D.B. 27°C (80°F) W.B. 19°C (66°F) Outdoor: D.B. 35°C (95°F) W.B. 24°C (75°F)
Refrigerant piping length (one way) : 5m (16ft.)

2. Guaranteed operating range

		Indoor	Outdoor
Cooling	Upper limit	D.B. 35°C, W.B. 22.5°C	D.B. 46°C
	Lower limit	D.B. 19°C, W.B. 15°C	D.B. -5°C

3. Guaranteed voltage
198-264V, 50Hz

4. Above data based on indicated voltage

Indoor unit Single phase 230V 50Hz
Outdoor unit Single phase 230V 50Hz, 3 phase 400V 50Hz

5. Refer to the service manual of outdoor unit for the outdoor unit's specifications.



Item		Service Ref.	PLA-RP3AA.UK PLA-RP3AA1.UK	PLA-RP4AA.UK PLA-RP4AA1.UK		
Function			Cooling			
Capacity		Btu/h	26,300	32,800		
		W	7,700	9,600		
Total input		kW	3.42	3.68		
Indoor unit	Service Ref.		PLA-RP3AA.UK PLA-RP3AA1.UK	PLA-RP4AA.UK PLA-RP4AA1.UK		
	Power supply (phase, cycle, voltage)		Single phase, 50Hz, 220-230-240V			
		Input	kW	0.16	0.25	
		Running current	A	0.79	1.25	
		Starting current	A	1.0	2.0	
	External finish (Panel)		Munsell 0.70Y 8.59/0.97			
	Heat exchanger		Plate fin coil			
	Fan	Fan (drive) × No.		Turbo fan (direct) × 1		
			Fan motor output	kW	0.070	0.120
			Airflow (Low-Medium2-Medium1-High)	m ³ / min (CFM)	15-16-18-20 (530-565-635-705)	20-23-26-28 (705-810-920-990)
			External static pressure	Pa (mmAq)	0 (direct blow)	
	Booster heater		kW	—		
	Operation control & Thermostat		Remote controller & built-in			
	Sound level (Low-Medium2-Medium1-High)		dB	28-30-32-34	33-36-39-41	
	Unit drain pipe I.D.		mm (in.)	32 (1-1/4)		
Dimensions	W	mm (in.)	UNIT : 840 (33-1/16), PANEL : 950 (37-3/8)	UNIT : 840 (33-1/16), PANEL : 950 (37-3/8)		
	D	mm (in.)	UNIT : 840 (33-1/16), PANEL : 950 (37-3/8)	UNIT : 840 (33-1/16), PANEL : 950 (37-3/8)		
	H	mm (in.)	UNIT : 258 (10-3/16), PANEL : 30 (1-3/16)	UNIT : 298 (11-3/4), PANEL : 30 (1-3/16)		
Weight		kg (lbs.)	UNIT : 24 (53), PANEL : 5 (11)	UNIT : 30 (66), PANEL : 5 (11)		
Outdoor unit Service Ref.			PU-P3VGAA.UK / PU-P3YGAA.UK PU-P3VGAA1.UK / PU-P3YGAA1.UK	PU-P4VGAA.UK / PU-P4YGAA.UK PU-P4VGAA1.UK / PU-P4YGAA1.UK		

Item		Service Ref.	PLA-RP5AA1.UK	PLA-RP6AA.UK PLA-RP6AA1.UK	
Function			Cooling		
Capacity		Btu/h	45,400	48,500	
		W	13,300	14,200	
Total input		kW	5.09	5.90	
Indoor unit	Service Ref.		PLA-RP5AA1.UK	PLA-RP6AA.UK PLA-RP6AA1.UK	
	Power supply (phase, cycle, voltage)		Single phase, 50Hz, 220-230-240V		
		Input	kW	0.33	0.33
		Running current	A	1.64	1.64
		Starting current	A	2.0	2.0
	External finish (Panel)		Munsell 0.70Y 8.59/0.97		
	Heat exchanger		Plate fin coil		
	Fan	Fan (drive) × No.		Turbo fan (direct) × 1	
			Fan motor output	kW	0.120
			Airflow (Low-Medium2-Medium1-High)	m ³ / min (CFM)	22-25-28-30 (775-880-990-1,060)
			External static pressure	Pa (mmAq)	0 (direct blow)
	Booster heater		kW	—	
	Operation control & Thermostat		Remote controller & built-in		
	Sound level (Low-Medium2-Medium1-High)		dB	37-40-43-45	
	Unit drain pipe I.D.		mm (in.)	32 (1-1/4)	
Dimensions	W	mm (in.)	UNIT : 840 (33-1/16), PANEL : 950 (37-3/8)	UNIT : 840 (33-1/16), PANEL : 950 (37-3/8)	
	D	mm (in.)	UNIT : 840 (33-1/16), PANEL : 950 (37-3/8)	UNIT : 840 (33-1/16), PANEL : 950 (37-3/8)	
	H	mm (in.)	UNIT : 298 (11-3/4), PANEL : 30 (1-3/16)	UNIT : 298 (11-3/4), PANEL : 30 (1-3/16)	
Weight		kg (lbs.)	UNIT : 32 (71),	PANEL : 5 (11)	
Outdoor unit Service Ref.			PU-P5YGAA.UK PU-P5YGAA1.UK	PU-P6YGAA.UK PU-P6YGAA1.UK	

- NOTE:**
- Rating conditions (ISO T1)
Cooling : Indoor: D.B. 27°C (80°F) W.B. 19°C (66°F) Outdoor: D.B. 35°C (95°F) W.B. 24°C (75°F)
Refrigerant piping length (one way) : 5m (16ft.)
 - Guaranteed operating range

		Indoor	Outdoor
Cooling	Upper limit	D.B. 35°C, W.B. 22.5°C	D.B. 46°C
	Lower limit	D.B. 19°C, W.B. 15°C	D.B. -5°C
 - Guaranteed voltage
198~264V, 50Hz
 - Above data based on indicated voltage
Indoor unit Single phase 230V 50Hz
Outdoor unit Single phase 230V 50Hz, 3 phase 400V 50Hz
 - Refer to the service manual of outdoor unit for the outdoor unit's specifications.

6

DATA

6-1. PERFORMANCE DATA

6-1-1. COOLING CAPACITY (1)

PLA-RP1.6AA.UK / PUHZ-RP1.6VHA

(230V)

Indoor intake air D.B.(°C)	Indoor intake air W.B.(°C)	Outdoor intake air D.B.(°C)											
		20				25				30			
		CA	SHC	SHF	P.C.	CA	SHC	SHF	P.C.	CA	SHC	SHF	P.C.
20	16	3564	2816	0.79	0.86	3456	2730	0.79	0.90	3348	2645	0.79	0.96
20	18	3816	2557	0.67	0.87	3708	2484	0.67	0.92	3582	2400	0.67	0.98
20	20	4104	2257	0.55	0.90	4014	2208	0.55	0.94	3906	2148	0.55	1.01
22	16	3564	3101	0.87	0.86	3456	3007	0.87	0.90	3348	2913	0.87	0.96
22	18	3816	2862	0.75	0.87	3708	2781	0.75	0.92	3582	2687	0.75	0.98
22	20	4104	2586	0.63	0.90	4014	2529	0.63	0.94	3906	2461	0.63	1.01
24	16	3564	3386	0.95	0.86	3456	3283	0.95	0.90	3348	3181	0.95	0.96
24	18	3816	3167	0.83	0.87	3708	3078	0.83	0.92	3582	2973	0.83	0.98
24	20	4104	2914	0.71	0.90	4014	2850	0.71	0.94	3906	2773	0.71	1.01
24	22	4374	2581	0.59	0.92	4284	2528	0.59	0.97	4176	2464	0.59	1.04
26	16	3564	3564	1.00	0.86	3456	3456	1.00	0.90	3348	3348	1.00	0.96
26	18	3816	3473	0.91	0.87	3708	3374	0.91	0.92	3582	3260	0.91	0.98
26	20	4104	3242	0.79	0.90	4014	3171	0.79	0.94	3906	3086	0.79	1.01
26	22	4374	2931	0.67	0.92	4284	2870	0.67	0.97	4176	2798	0.67	1.04
27	16	3564	3564	1.00	0.86	3456	3456	1.00	0.90	3348	3348	1.00	0.96
27	18	3816	3625	0.95	0.87	3708	3523	0.95	0.92	3582	3403	0.95	0.98
27	20	4104	3406	0.83	0.90	4014	3332	0.83	0.94	3906	3242	0.83	1.01
27	22	4374	3106	0.71	0.92	4284	3042	0.71	0.97	4176	2965	0.71	1.04
28	16	3564	3564	1.00	0.86	3456	3456	1.00	0.90	3348	3348	1.00	0.96
28	18	3816	3778	0.99	0.87	3708	3671	0.99	0.92	3582	3546	0.99	0.98
28	20	4104	3570	0.87	0.90	4014	3492	0.87	0.94	3906	3398	0.87	1.01
28	22	4374	3281	0.75	0.92	4284	3213	0.75	0.97	4176	3132	0.75	1.04
30	16	3564	3564	1.00	0.86	3456	3456	1.00	0.90	3348	3348	1.00	0.96
30	18	3816	3816	1.00	0.87	3708	3708	1.00	0.92	3582	3582	1.00	0.98
30	20	4104	3899	0.95	0.90	4014	3813	0.95	0.94	3906	3711	0.95	1.01
30	22	4374	3630	0.83	0.92	4284	3556	0.83	0.97	4176	3466	0.83	1.04
32	16	3564	3564	1.00	0.86	3456	3456	1.00	0.90	3348	3348	1.00	0.96
32	18	3816	3816	1.00	0.87	3708	3708	1.00	0.92	3582	3582	1.00	0.98
32	20	4104	4104	1.00	0.90	4014	4014	1.00	0.94	3906	3906	1.00	1.01
32	22	4374	3980	0.91	0.92	4284	3898	0.91	0.97	4176	3800	0.91	1.04
34	16	3564	3564	1.00	0.86	3456	3456	1.00	0.90	3348	3348	1.00	0.96
34	18	3816	3816	1.00	0.87	3708	3708	1.00	0.92	3582	3582	1.00	0.98
34	20	4104	4104	1.00	0.90	4014	4014	1.00	0.94	3906	3906	1.00	1.01
34	22	4374	4330	0.99	0.92	4284	4241	0.99	0.97	4176	4134	0.99	1.04

NOTE: CA : Capacity (W) SHC: Sensible heat capacity (W)
P.C.: Power consumption (kW) SHF: Sensible heat factor

**COOLING CAPACITY (2)
PLA-RP1.6AA.UK / PUHZ-RP1.6VHA**

(230V)

Indoor intake air D.B.(°C)	Indoor intake air W.B.(°C)	Outdoor intake air D.B.(°C)											
		35				40				45			
		CA	SHC	SHF	P.C.	CA	SHC	SHF	P.C.	CA	SHC	SHF	P.C.
20	16	3204	2531	0.79	1.03	3060	2417	0.79	1.10	2916	2304	0.79	1.19
20	18	3456	2316	0.67	1.05	3348	2243	0.67	1.13	3132	2098	0.67	1.22
20	20	3744	2059	0.55	1.08	3600	1980	0.55	1.16	3384	1861	0.55	1.24
22	16	3204	2787	0.87	1.03	3060	2662	0.87	1.10	2916	2537	0.87	1.19
22	18	3456	2592	0.75	1.05	3348	2511	0.75	1.13	3132	2349	0.75	1.22
22	20	3744	2359	0.63	1.08	3600	2268	0.63	1.16	3384	2132	0.63	1.24
24	16	3204	3044	0.95	1.03	3060	2907	0.95	1.10	2916	2770	0.95	1.19
24	18	3456	2868	0.83	1.05	3348	2779	0.83	1.13	3132	2600	0.83	1.22
24	20	3744	2658	0.71	1.08	3600	2556	0.71	1.16	3384	2403	0.71	1.24
24	22	4032	2379	0.59	1.10	3888	2294	0.59	1.19	3672	2166	0.59	1.26
26	16	3204	3204	1.00	1.03	3060	3060	1.00	1.10	2916	2916	1.00	1.19
26	18	3456	3145	0.91	1.05	3348	3047	0.91	1.13	3132	2850	0.91	1.22
26	20	3744	2958	0.79	1.08	3600	2844	0.79	1.16	3384	2673	0.79	1.24
26	22	4032	2701	0.67	1.10	3888	2605	0.67	1.19	3672	2460	0.67	1.26
27	16	3204	3204	1.00	1.03	3060	3060	1.00	1.10	2916	2916	1.00	1.19
27	18	3456	3283	0.95	1.05	3348	3181	0.95	1.13	3132	2975	0.95	1.22
27	20	3744	3108	0.83	1.08	3600	2988	0.83	1.16	3384	2809	0.83	1.24
27	22	4032	2863	0.71	1.10	3888	2760	0.71	1.19	3672	2607	0.71	1.26
28	16	3204	3204	1.00	1.03	3060	3060	1.00	1.10	2916	2916	1.00	1.19
28	18	3456	3421	0.99	1.05	3348	3315	0.99	1.13	3132	3101	0.99	1.22
28	20	3744	3257	0.87	1.08	3600	3132	0.87	1.16	3384	2944	0.87	1.24
28	22	4032	3024	0.75	1.10	3888	2916	0.75	1.19	3672	2754	0.75	1.26
30	16	3204	3204	1.00	1.03	3060	3060	1.00	1.10	2916	2916	1.00	1.19
30	18	3456	3456	1.00	1.05	3348	3348	1.00	1.13	3132	3132	1.00	1.22
30	20	3744	3557	0.95	1.08	3600	3420	0.95	1.16	3384	3215	0.95	1.24
30	22	4032	3347	0.83	1.10	3888	3227	0.83	1.19	3672	3048	0.83	1.26
32	16	3204	3204	1.00	1.03	3060	3060	1.00	1.10	2916	2916	1.00	1.19
32	18	3456	3456	1.00	1.05	3348	3348	1.00	1.13	3132	3132	1.00	1.22
32	20	3744	3744	1.00	1.08	3600	3600	1.00	1.16	3384	3384	1.00	1.24
32	22	4032	3669	0.91	1.10	3888	3538	0.91	1.19	3672	3342	0.91	1.26
34	16	3204	3204	1.00	1.03	3060	3060	1.00	1.10	2916	2916	1.00	1.19
34	18	3456	3456	1.00	1.05	3348	3348	1.00	1.13	3132	3132	1.00	1.22
34	20	3744	3744	1.00	1.08	3600	3600	1.00	1.16	3384	3384	1.00	1.24
34	22	4032	3992	0.99	1.10	3888	3849	0.99	1.19	3672	3635	0.99	1.26

NOTE: CA : Capacity (W) SHC: Sensible heat capacity (W)
P.C.: Power consumption (kW) SHF: Sensible heat factor

**COOLING CAPACITY (3)
PLA-RP2AA.UK / PUHZ-RP2VHA**

(230V)

Indoor intake air D.B.(°C)	Indoor intake air W.B.(°C)	Outdoor intake air D.B.(°C)											
		20				25				30			
		CA	SHC	SHF	P.C.	CA	SHC	SHF	P.C.	CA	SHC	SHF	P.C.
20	16	4950	3762	0.76	1.24	4800	3648	0.76	1.31	4650	3534	0.76	1.39
20	18	5300	3392	0.64	1.26	5150	3296	0.64	1.33	4975	3184	0.64	1.43
20	20	5700	2964	0.52	1.30	5575	2899	0.52	1.36	5425	2821	0.52	1.46
22	16	4950	4158	0.84	1.24	4800	4032	0.84	1.31	4650	3906	0.84	1.39
22	18	5300	3816	0.72	1.26	5150	3708	0.72	1.33	4975	3582	0.72	1.43
22	20	5700	3420	0.60	1.30	5575	3345	0.60	1.36	5425	3255	0.60	1.46
24	16	4950	4554	0.92	1.24	4800	4416	0.92	1.31	4650	4278	0.92	1.39
24	18	5300	4240	0.80	1.26	5150	4120	0.80	1.33	4975	3980	0.80	1.43
24	20	5700	3876	0.68	1.30	5575	3791	0.68	1.36	5425	3689	0.68	1.46
24	22	6075	3402	0.56	1.33	5950	3332	0.56	1.41	5800	3248	0.56	1.50
26	16	4950	4950	1.00	1.24	4800	4800	1.00	1.31	4650	4650	1.00	1.39
26	18	5300	4664	0.88	1.26	5150	4532	0.88	1.33	4975	4378	0.88	1.43
26	20	5700	4332	0.76	1.30	5575	4237	0.76	1.36	5425	4123	0.76	1.46
26	22	6075	3888	0.64	1.33	5950	3808	0.64	1.41	5800	3712	0.64	1.50
27	16	4950	4950	1.00	1.24	4800	4800	1.00	1.31	4650	4650	1.00	1.39
27	18	5300	4876	0.92	1.26	5150	4738	0.92	1.33	4975	4577	0.92	1.43
27	20	5700	4560	0.80	1.30	5575	4460	0.80	1.36	5425	4340	0.80	1.46
27	22	6075	4131	0.68	1.33	5950	4046	0.68	1.41	5800	3944	0.68	1.50
28	16	4950	4950	1.00	1.24	4800	4800	1.00	1.31	4650	4650	1.00	1.39
28	18	5300	5088	0.96	1.26	5150	4944	0.96	1.33	4975	4776	0.96	1.43
28	20	5700	4788	0.84	1.30	5575	4683	0.84	1.36	5425	4557	0.84	1.46
28	22	6075	4374	0.72	1.33	5950	4284	0.72	1.41	5800	4176	0.72	1.50
30	16	4950	4950	1.00	1.24	4800	4800	1.00	1.31	4650	4650	1.00	1.39
30	18	5300	5300	1.00	1.26	5150	5150	1.00	1.33	4975	4975	1.00	1.43
30	20	5700	5244	0.92	1.30	5575	5129	0.92	1.36	5425	4991	0.92	1.46
30	22	6075	4860	0.80	1.33	5950	4760	0.80	1.41	5800	4640	0.80	1.50
32	16	4950	4950	1.00	1.24	4800	4800	1.00	1.31	4650	4650	1.00	1.39
32	18	5300	5300	1.00	1.26	5150	5150	1.00	1.33	4975	4975	1.00	1.43
32	20	5700	5700	1.00	1.30	5575	5575	1.00	1.36	5425	5425	1.00	1.46
32	22	6075	5346	0.88	1.33	5950	5236	0.88	1.41	5800	5104	0.88	1.50
34	16	4950	4950	1.00	1.24	4800	4800	1.00	1.31	4650	4650	1.00	1.39
34	18	5300	5300	1.00	1.26	5150	5150	1.00	1.33	4975	4975	1.00	1.43
34	20	5700	5700	1.00	1.30	5575	5575	1.00	1.36	5425	5425	1.00	1.46
34	22	6075	5832	0.96	1.33	5950	5712	0.96	1.41	5800	5568	0.96	1.50

NOTE: CA : Capacity (W) SHC: Sensible heat capacity (W)
P.C.: Power consumption (kW) SHF: Sensible heat factor

**COOLING CAPACITY (4)
PLA-RP2AA.UK / PUHZ-RP2VHA**

(230V)

Indoor intake air D.B.(°C)	Indoor intake air W.B.(°C)	Outdoor intake air D.B.(°C)											
		35				40				45			
		CA	SHC	SHF	P.C.	CA	SHC	SHF	P.C.	CA	SHC	SHF	P.C.
20	16	4450	3382	0.76	1.49	4250	3230	0.76	1.60	4050	3078	0.76	1.73
20	18	4800	3072	0.64	1.53	4650	2976	0.64	1.64	4350	2784	0.64	1.77
20	20	5200	2704	0.52	1.57	5000	2600	0.52	1.67	4700	2444	0.52	1.80
22	16	4450	3738	0.84	1.49	4250	3570	0.84	1.60	4050	3402	0.84	1.73
22	18	4800	3456	0.72	1.53	4650	3348	0.72	1.64	4350	3132	0.72	1.77
22	20	5200	3120	0.60	1.57	5000	3000	0.60	1.67	4700	2820	0.60	1.80
24	16	4450	4094	0.92	1.49	4250	3910	0.92	1.60	4050	3726	0.92	1.73
24	18	4800	3840	0.80	1.53	4650	3720	0.80	1.64	4350	3480	0.80	1.77
24	20	5200	3536	0.68	1.57	5000	3400	0.68	1.67	4700	3196	0.68	1.80
24	22	5600	3136	0.56	1.60	5400	3024	0.56	1.72	5100	2856	0.56	1.83
26	16	4450	4450	1.00	1.49	4250	4250	1.00	1.60	4050	4050	1.00	1.73
26	18	4800	4224	0.88	1.53	4650	4092	0.88	1.64	4350	3828	0.88	1.77
26	20	5200	3952	0.76	1.57	5000	3800	0.76	1.67	4700	3572	0.76	1.80
26	22	5600	3584	0.64	1.60	5400	3456	0.64	1.72	5100	3264	0.64	1.83
27	16	4450	4450	1.00	1.49	4250	4250	1.00	1.60	4050	4050	1.00	1.73
27	18	4800	4416	0.92	1.53	4650	4278	0.92	1.64	4350	4002	0.92	1.77
27	20	5200	4160	0.80	1.57	5000	4000	0.80	1.67	4700	3760	0.80	1.80
27	22	5600	3808	0.68	1.60	5400	3672	0.68	1.72	5100	3468	0.68	1.83
28	16	4450	4450	1.00	1.49	4250	4250	1.00	1.60	4050	4050	1.00	1.73
28	18	4800	4608	0.96	1.53	4650	4464	0.96	1.64	4350	4176	0.96	1.77
28	20	5200	4368	0.84	1.57	5000	4200	0.84	1.67	4700	3948	0.84	1.80
28	22	5600	4032	0.72	1.60	5400	3888	0.72	1.72	5100	3672	0.72	1.83
30	16	4450	4450	1.00	1.49	4250	4250	1.00	1.60	4050	4050	1.00	1.73
30	18	4800	4800	1.00	1.53	4650	4650	1.00	1.64	4350	4350	1.00	1.77
30	20	5200	4784	0.92	1.57	5000	4600	0.92	1.67	4700	4324	0.92	1.80
30	22	5600	4480	0.80	1.60	5400	4320	0.80	1.72	5100	4080	0.80	1.83
32	16	4450	4450	1.00	1.49	4250	4250	1.00	1.60	4050	4050	1.00	1.73
32	18	4800	4800	1.00	1.53	4650	4650	1.00	1.64	4350	4350	1.00	1.77
32	20	5200	5200	1.00	1.57	5000	5000	1.00	1.67	4700	4700	1.00	1.80
32	22	5600	4928	0.88	1.60	5400	4752	0.88	1.72	5100	4488	0.88	1.83
34	16	4450	4450	1.00	1.49	4250	4250	1.00	1.60	4050	4050	1.00	1.73
34	18	4800	4800	1.00	1.53	4650	4650	1.00	1.64	4350	4350	1.00	1.77
34	20	5200	5200	1.00	1.57	5000	5000	1.00	1.67	4700	4700	1.00	1.80
34	22	5600	5376	0.96	1.60	5400	5184	0.96	1.72	5100	4896	0.96	1.83

NOTE: CA : Capacity (W) SHC: Sensible heat capacity (W)
P.C.: Power consumption (kW) SHF: Sensible heat factor

COOLING CAPACITY (5)

PLA-RP2.5AA.UK / PUAZ-RP2.5VHA

PUHZ-RP2.5VHA₁

(230V)

Indoor intake air D.B.(°C)	Indoor intake air W.B.(°C)	Outdoor intake air D.B.(°C)											
		20				25				30			
		CA	SHC	SHF	P.C.	CA	SHC	SHF	P.C.	CA	SHC	SHF	P.C.
20	16	5940	4039	0.68	1.32	5760	3917	0.68	1.39	5580	3794	0.68	1.48
20	18	6360	3562	0.56	1.34	6180	3461	0.56	1.42	5970	3343	0.56	1.52
20	20	6840	3010	0.44	1.39	6690	2944	0.44	1.45	6510	2864	0.44	1.55
22	16	5940	4514	0.76	1.32	5760	4378	0.76	1.39	5580	4241	0.76	1.48
22	18	6360	4070	0.64	1.34	6180	3955	0.64	1.42	5970	3821	0.64	1.52
22	20	6840	3557	0.52	1.39	6690	3479	0.52	1.45	6510	3385	0.52	1.55
24	16	5940	4990	0.84	1.32	5760	4838	0.84	1.39	5580	4687	0.84	1.48
24	18	6360	4579	0.72	1.34	6180	4450	0.72	1.42	5970	4298	0.72	1.52
24	20	6840	4104	0.60	1.39	6690	4014	0.60	1.45	6510	3906	0.60	1.55
24	22	7290	3499	0.48	1.42	7140	3427	0.48	1.50	6960	3341	0.48	1.60
26	16	5940	5465	0.92	1.32	5760	5299	0.92	1.39	5580	5134	0.92	1.48
26	18	6360	5088	0.80	1.34	6180	4944	0.80	1.42	5970	4776	0.80	1.52
26	20	6840	4651	0.68	1.39	6690	4549	0.68	1.45	6510	4427	0.68	1.55
26	22	7290	4082	0.56	1.42	7140	3998	0.56	1.50	6960	3898	0.56	1.60
27	16	5940	5702	0.96	1.32	5760	5530	0.96	1.39	5580	5357	0.96	1.48
27	18	6360	5342	0.84	1.34	6180	5191	0.84	1.42	5970	5015	0.84	1.52
27	20	6840	4925	0.72	1.39	6690	4817	0.72	1.45	6510	4687	0.72	1.55
27	22	7290	4374	0.60	1.42	7140	4284	0.60	1.50	6960	4176	0.60	1.60
28	16	5940	5940	1.00	1.32	5760	5760	1.00	1.39	5580	5580	1.00	1.48
28	18	6360	5597	0.88	1.34	6180	5438	0.88	1.42	5970	5254	0.88	1.52
28	20	6840	5198	0.76	1.39	6690	5084	0.76	1.45	6510	4948	0.76	1.55
28	22	7290	4666	0.64	1.42	7140	4570	0.64	1.50	6960	4454	0.64	1.60
30	16	5940	5940	1.00	1.32	5760	5760	1.00	1.39	5580	5580	1.00	1.48
30	18	6360	6106	0.96	1.34	6180	5933	0.96	1.42	5970	5731	0.96	1.52
30	20	6840	5746	0.84	1.39	6690	5620	0.84	1.45	6510	5468	0.84	1.55
30	22	7290	5249	0.72	1.42	7140	5141	0.72	1.50	6960	5011	0.72	1.60
32	16	5940	5940	1.00	1.32	5760	5760	1.00	1.39	5580	5580	1.00	1.48
32	18	6360	6360	1.00	1.34	6180	6180	1.00	1.42	5970	5970	1.00	1.52
32	20	6840	6293	0.92	1.39	6690	6155	0.92	1.45	6510	5989	0.92	1.55
32	22	7290	5832	0.80	1.42	7140	5712	0.80	1.50	6960	5568	0.80	1.60
34	16	5940	5940	1.00	1.32	5760	5760	1.00	1.39	5580	5580	1.00	1.48
34	18	6360	6360	1.00	1.34	6180	6180	1.00	1.42	5970	5970	1.00	1.52
34	20	6840	6840	1.00	1.39	6690	6690	1.00	1.45	6510	6510	1.00	1.55
34	22	7290	6415	0.88	1.42	7140	6283	0.88	1.50	6960	6125	0.88	1.60

NOTE: CA : Capacity (W) SHC: Sensible heat capacity (W)
P.C.: Power consumption (kW) SHF: Sensible heat factor

COOLING CAPACITY (6)

PLA-RP2.5AA.UK / PUAZ-RP2.5VHA

PUHZ-RP2.5VHA₁

(230V)

Indoor intake air D.B.(°C)	Indoor intake air W.B.(°C)	Outdoor intake air D.B.(°C)											
		35				40				45			
		CA	SHC	SHF	P.C.	CA	SHC	SHF	P.C.	CA	SHC	SHF	P.C.
20	16	5340	3631	0.68	1.58	5100	3468	0.68	1.70	4860	3305	0.68	1.84
20	18	5760	3226	0.56	1.63	5580	3125	0.56	1.75	5220	2923	0.56	1.88
20	20	6240	2746	0.44	1.67	6000	2640	0.44	1.78	5640	2482	0.44	1.91
22	16	5340	4058	0.76	1.58	5100	3876	0.76	1.70	4860	3694	0.76	1.84
22	18	5760	3686	0.64	1.63	5580	3571	0.64	1.75	5220	3341	0.64	1.88
22	20	6240	3245	0.52	1.67	6000	3120	0.52	1.78	5640	2933	0.52	1.91
24	16	5340	4486	0.84	1.58	5100	4284	0.84	1.70	4860	4082	0.84	1.84
24	18	5760	4147	0.72	1.63	5580	4018	0.72	1.75	5220	3758	0.72	1.88
24	20	6240	3744	0.60	1.67	6000	3600	0.60	1.78	5640	3384	0.60	1.91
24	22	6720	3226	0.48	1.70	6480	3110	0.48	1.83	6120	2938	0.48	1.95
26	16	5340	4913	0.92	1.58	5100	4692	0.92	1.70	4860	4471	0.92	1.84
26	18	5760	4608	0.80	1.63	5580	4464	0.80	1.75	5220	4176	0.80	1.88
26	20	6240	4243	0.68	1.67	6000	4080	0.68	1.78	5640	3835	0.68	1.91
26	22	6720	3763	0.56	1.70	6480	3629	0.56	1.83	6120	3427	0.56	1.95
27	16	5340	5126	0.96	1.58	5100	4896	0.96	1.70	4860	4666	0.96	1.84
27	18	5760	4838	0.84	1.63	5580	4687	0.84	1.75	5220	4385	0.84	1.88
27	20	6240	4493	0.72	1.67	6000	4320	0.72	1.78	5640	4061	0.72	1.91
27	22	6720	4032	0.60	1.70	6480	3888	0.60	1.83	6120	3672	0.60	1.95
28	16	5340	5340	1.00	1.58	5100	5100	1.00	1.70	4860	4860	1.00	1.84
28	18	5760	5069	0.88	1.63	5580	4910	0.88	1.75	5220	4594	0.88	1.88
28	20	6240	4742	0.76	1.67	6000	4560	0.76	1.78	5640	4286	0.76	1.91
28	22	6720	4301	0.64	1.70	6480	4147	0.64	1.83	6120	3917	0.64	1.95
30	16	5340	5340	1.00	1.58	5100	5100	1.00	1.70	4860	4860	1.00	1.84
30	18	5760	5530	0.96	1.63	5580	5357	0.96	1.75	5220	5011	0.96	1.88
30	20	6240	5242	0.84	1.67	6000	5040	0.84	1.78	5640	4738	0.84	1.91
30	22	6720	4838	0.72	1.70	6480	4666	0.72	1.83	6120	4406	0.72	1.95
32	16	5340	5340	1.00	1.58	5100	5100	1.00	1.70	4860	4860	1.00	1.84
32	18	5760	5760	1.00	1.63	5580	5580	1.00	1.75	5220	5220	1.00	1.88
32	20	6240	5741	0.92	1.67	6000	5520	0.92	1.78	5640	5189	0.92	1.91
32	22	6720	5376	0.80	1.70	6480	5184	0.80	1.83	6120	4896	0.80	1.95
34	16	5340	5340	1.00	1.58	5100	5100	1.00	1.70	4860	4860	1.00	1.84
34	18	5760	5760	1.00	1.63	5580	5580	1.00	1.75	5220	5220	1.00	1.88
34	20	6240	6240	1.00	1.67	6000	6000	1.00	1.78	5640	5640	1.00	1.91
34	22	6720	5914	0.88	1.70	6480	5702	0.88	1.83	6120	5386	0.88	1.95

NOTE: CA : Capacity (W) SHC: Sensible heat capacity (W)
P.C.: Power consumption (kW) SHF: Sensible heat factor

COOLING CAPACITY (7)

**PLA-RP3AA.UK PLA-RP3AA₁.UK / PUIZ-RP3VHA
PUIZ-RP3VHA₁**

(230V)

Indoor intake air D.B.(°C)	Indoor intake air W.B.(°C)	Outdoor intake air D.B.(°C)											
		20				25				30			
		CA	SHC	SHF	P.C.	CA	SHC	SHF	P.C.	CA	SHC	SHF	P.C.
20	16	7,029	4,499	0.64	1.58	6,816	4,362	0.64	1.66	6,603	4,226	0.64	1.76
20	18	7,526	3,914	0.52	1.61	7,313	3,803	0.52	1.69	7,065	3,674	0.52	1.81
20	20	8,094	3,238	0.40	1.65	7,917	3,167	0.40	1.73	7,704	3,081	0.40	1.85
22	16	7,029	5,061	0.72	1.58	6,816	4,908	0.72	1.66	6,603	4,754	0.72	1.76
22	18	7,526	4,516	0.60	1.61	7,313	4,388	0.60	1.69	7,065	4,239	0.60	1.81
22	20	8,094	3,885	0.48	1.65	7,917	3,800	0.48	1.73	7,704	3,698	0.48	1.85
24	16	7,029	5,623	0.80	1.58	6,816	5,453	0.80	1.66	6,603	5,282	0.80	1.76
24	18	7,526	5,118	0.68	1.61	7,313	4,973	0.68	1.69	7,065	4,804	0.68	1.81
24	20	8,094	4,533	0.56	1.65	7,917	4,433	0.56	1.73	7,704	4,314	0.56	1.85
24	22	8,627	3,796	0.44	1.69	8,449	3,718	0.44	1.79	8,236	3,624	0.44	1.91
26	16	7,029	6,186	0.88	1.58	6,816	5,998	0.88	1.66	6,603	5,811	0.88	1.76
26	18	7,526	5,720	0.76	1.61	7,313	5,558	0.76	1.69	7,065	5,369	0.76	1.81
26	20	8,094	5,180	0.64	1.65	7,917	5,067	0.64	1.73	7,704	4,930	0.64	1.85
26	22	8,627	4,486	0.52	1.69	8,449	4,393	0.52	1.79	8,236	4,283	0.52	1.91
27	16	7,029	6,467	0.92	1.58	6,816	6,271	0.92	1.66	6,603	6,075	0.92	1.76
27	18	7,526	6,021	0.80	1.61	7,313	5,850	0.80	1.69	7,065	5,652	0.80	1.81
27	20	8,094	5,504	0.68	1.65	7,917	5,383	0.68	1.73	7,704	5,238	0.68	1.85
27	22	8,627	4,831	0.56	1.69	8,449	4,731	0.56	1.79	8,236	4,612	0.56	1.91
28	16	7,029	6,748	0.96	1.58	6,816	6,543	0.96	1.66	6,603	6,339	0.96	1.76
28	18	7,526	6,322	0.84	1.61	7,313	6,143	0.84	1.69	7,065	5,934	0.84	1.81
28	20	8,094	5,828	0.72	1.65	7,917	5,700	0.72	1.73	7,704	5,547	0.72	1.85
28	22	8,627	5,176	0.60	1.69	8,449	5,069	0.60	1.79	8,236	4,942	0.60	1.91
30	16	7,029	7,029	1.00	1.58	6,816	6,816	1.00	1.66	6,603	6,603	1.00	1.76
30	18	7,526	6,924	0.92	1.61	7,313	6,728	0.92	1.69	7,065	6,499	0.92	1.81
30	20	8,094	6,475	0.80	1.65	7,917	6,333	0.80	1.73	7,704	6,163	0.80	1.85
30	22	8,627	5,866	0.68	1.69	8,449	5,745	0.68	1.79	8,236	5,600	0.68	1.91
32	16	7,029	7,029	1.00	1.58	6,816	6,816	1.00	1.66	6,603	6,603	1.00	1.76
32	18	7,526	7,526	1.00	1.61	7,313	7,313	1.00	1.69	7,065	7,065	1.00	1.81
32	20	8,094	7,123	0.88	1.65	7,917	6,967	0.88	1.73	7,704	6,779	0.88	1.85
32	22	8,627	6,556	0.76	1.69	8,449	6,421	0.76	1.79	8,236	6,259	0.76	1.91
34	16	7,029	7,029	1.00	1.58	6,816	6,816	1.00	1.66	6,603	6,603	1.00	1.76
34	18	7,526	7,526	1.00	1.61	7,313	7,313	1.00	1.69	7,065	7,065	1.00	1.81
34	20	8,094	7,770	0.96	1.65	7,917	7,600	0.96	1.73	7,704	7,395	0.96	1.85
34	22	8,627	7,246	0.84	1.69	8,449	7,097	0.84	1.79	8,236	6,918	0.84	1.91

NOTE: CA : Capacity (W) SHC: Sensible heat capacity (W)
P.C.: Power consumption (kW) SHF: Sensible heat factor

COOLING CAPACITY (8)

PLA-RP3AA.UK PLA-RP3AA₁.UK / PUIHZ-RP3VHA

PUHZ-RP3VHA₁

(230V)

Indoor intake air D.B.(°C)	Indoor intake air W.B.(°C)	Outdoor intake air D.B.(°C)											
		35				40				45			
		CA	SHC	SHF	P.C.	CA	SHC	SHF	P.C.	CA	SHC	SHF	P.C.
20	16	6,319	4,044	0.64	1.89	6,035	3,862	0.64	2.03	5,751	3,681	0.64	2.20
20	18	6,816	3,544	0.52	1.94	6,603	3,434	0.52	2.09	6,177	3,212	0.52	2.25
20	20	7,384	2,954	0.40	1.99	7,100	2,840	0.40	2.13	6,674	2,670	0.40	2.29
22	16	6,319	4,550	0.72	1.89	6,035	4,345	0.72	2.03	5,751	4,141	0.72	2.20
22	18	6,816	4,090	0.60	1.94	6,603	3,962	0.60	2.09	6,177	3,706	0.60	2.25
22	20	7,384	3,544	0.48	1.99	7,100	3,408	0.48	2.13	6,674	3,204	0.48	2.29
24	16	6,319	5,055	0.80	1.89	6,035	4,828	0.80	2.03	5,751	4,601	0.80	2.20
24	18	6,816	4,635	0.68	1.94	6,603	4,490	0.68	2.09	6,177	4,200	0.68	2.25
24	20	7,384	4,135	0.56	1.99	7,100	3,976	0.56	2.13	6,674	3,737	0.56	2.29
24	22	7,952	3,499	0.44	2.03	7,668	3,374	0.44	2.19	7,242	3,186	0.44	2.32
26	16	6,319	5,561	0.88	1.89	6,035	5,311	0.88	2.03	5,751	5,061	0.88	2.20
26	18	6,816	5,180	0.76	1.94	6,603	5,018	0.76	2.09	6,177	4,695	0.76	2.25
26	20	7,384	4,726	0.64	1.99	7,100	4,544	0.64	2.13	6,674	4,271	0.64	2.29
26	22	7,952	4,135	0.52	2.03	7,668	3,987	0.52	2.19	7,242	3,766	0.52	2.32
27	16	6,319	5,813	0.92	1.89	6,035	5,552	0.92	2.03	5,751	5,291	0.92	2.20
27	18	6,816	5,453	0.80	1.94	6,603	5,282	0.80	2.09	6,177	4,942	0.80	2.25
27	20	7,384	5,021	0.68	1.99	7,100	4,828	0.68	2.13	6,674	4,538	0.68	2.29
27	22	7,952	4,453	0.56	2.03	7,668	4,294	0.56	2.19	7,242	4,056	0.56	2.32
28	16	6,319	6,066	0.96	1.89	6,035	5,794	0.96	2.03	5,751	5,521	0.96	2.20
28	18	6,816	5,725	0.84	1.94	6,603	5,547	0.84	2.09	6,177	5,189	0.84	2.25
28	20	7,384	5,316	0.72	1.99	7,100	5,112	0.72	2.13	6,674	4,805	0.72	2.29
28	22	7,952	4,771	0.60	2.03	7,668	4,601	0.60	2.19	7,242	4,345	0.60	2.32
30	16	6,319	6,319	1.00	1.89	6,035	6,035	1.00	2.03	5,751	5,751	1.00	2.20
30	18	6,816	6,271	0.92	1.94	6,603	6,075	0.92	2.09	6,177	5,683	0.92	2.25
30	20	7,384	5,907	0.80	1.99	7,100	5,680	0.80	2.13	6,674	5,339	0.80	2.29
30	22	7,952	5,407	0.68	2.03	7,668	5,214	0.68	2.19	7,242	4,925	0.68	2.32
32	16	6,319	6,319	1.00	1.89	6,035	6,035	1.00	2.03	5,751	5,751	1.00	2.20
32	18	6,816	6,816	1.00	1.94	6,603	6,603	1.00	2.09	6,177	6,177	1.00	2.25
32	20	7,384	6,498	0.88	1.99	7,100	6,248	0.88	2.13	6,674	5,873	0.88	2.29
32	22	7,952	6,044	0.76	2.03	7,668	5,828	0.76	2.19	7,242	5,504	0.76	2.32
34	16	6,319	6,319	1.00	1.89	6,035	6,035	1.00	2.03	5,751	5,751	1.00	2.20
34	18	6,816	6,816	1.00	1.94	6,603	6,603	1.00	2.09	6,177	6,177	1.00	2.25
34	20	7,384	7,089	0.96	1.99	7,100	6,816	0.96	2.13	6,674	6,407	0.96	2.29
34	22	7,952	6,680	0.84	2.03	7,668	6,441	0.84	2.19	7,242	6,083	0.84	2.32

NOTE: CA : Capacity (W) SHC: Sensible heat capacity (W)
P.C.: Power consumption (kW) SHF: Sensible heat factor

COOLING CAPACITY (9)

**PLA-RP4AA.UK PLA-RP4AA₁.UK / PUIHZ-RP4VHA
PUIHZ-RP4VHA₁**

(230V)

Indoor intake air D.B.(°C)	Indoor intake air W.B.(°C)	Outdoor intake air D.B.(°C)											
		20				25				30			
		CA	SHC	SHF	P.C.	CA	SHC	SHF	P.C.	CA	SHC	SHF	P.C.
20	16	9,900	6,435	0.65	2.42	9,600	6,240	0.65	2.56	9,300	6,045	0.65	2.71
20	18	10,600	5,618	0.53	2.47	10,300	5,459	0.53	2.61	9,950	5,274	0.53	2.79
20	20	11,400	4,674	0.41	2.55	11,150	4,572	0.41	2.67	10,850	4,449	0.41	2.85
22	16	9,900	7,227	0.73	2.42	9,600	7,008	0.73	2.56	9,300	6,789	0.73	2.71
22	18	10,600	6,466	0.61	2.47	10,300	6,283	0.61	2.61	9,950	6,070	0.61	2.79
22	20	11,400	5,586	0.49	2.55	11,150	5,464	0.49	2.67	10,850	5,317	0.49	2.85
24	16	9,900	8,019	0.81	2.42	9,600	7,776	0.81	2.56	9,300	7,533	0.81	2.71
24	18	10,600	7,314	0.69	2.47	10,300	7,107	0.69	2.61	9,950	6,866	0.69	2.79
24	20	11,400	6,498	0.57	2.55	11,150	6,356	0.57	2.67	10,850	6,185	0.57	2.85
24	22	12,150	5,468	0.45	2.61	11,900	5,355	0.45	2.76	11,600	5,220	0.45	2.94
26	16	9,900	8,811	0.89	2.42	9,600	8,544	0.89	2.56	9,300	8,277	0.89	2.71
26	18	10,600	8,162	0.77	2.47	10,300	7,931	0.77	2.61	9,950	7,662	0.77	2.79
26	20	11,400	7,410	0.65	2.55	11,150	7,248	0.65	2.67	10,850	7,053	0.65	2.85
26	22	12,150	6,440	0.53	2.61	11,900	6,307	0.53	2.76	11,600	6,148	0.53	2.94
27	16	9,900	9,207	0.93	2.42	9,600	8,928	0.93	2.56	9,300	8,649	0.93	2.71
27	18	10,600	8,586	0.81	2.47	10,300	8,343	0.81	2.61	9,950	8,060	0.81	2.79
27	20	11,400	7,866	0.69	2.55	11,150	7,694	0.69	2.67	10,850	7,487	0.69	2.85
27	22	12,150	6,926	0.57	2.61	11,900	6,783	0.57	2.76	11,600	6,612	0.57	2.94
28	16	9,900	9,603	0.97	2.42	9,600	9,312	0.97	2.56	9,300	9,021	0.97	2.71
28	18	10,600	9,010	0.85	2.47	10,300	8,755	0.85	2.61	9,950	8,458	0.85	2.79
28	20	11,400	8,322	0.73	2.55	11,150	8,140	0.73	2.67	10,850	7,921	0.73	2.85
28	22	12,150	7,412	0.61	2.61	11,900	7,259	0.61	2.76	11,600	7,076	0.61	2.94
30	16	9,900	9,900	1.00	2.42	9,600	9,600	1.00	2.56	9,300	9,300	1.00	2.71
30	18	10,600	9,858	0.93	2.47	10,300	9,579	0.93	2.61	9,950	9,254	0.93	2.79
30	20	11,400	9,234	0.81	2.55	11,150	9,032	0.81	2.67	10,850	8,789	0.81	2.85
30	22	12,150	8,384	0.69	2.61	11,900	8,211	0.69	2.76	11,600	8,004	0.69	2.94
32	16	9,900	9,900	1.00	2.42	9,600	9,600	1.00	2.56	9,300	9,300	1.00	2.71
32	18	10,600	10,600	1.00	2.47	10,300	10,300	1.00	2.61	9,950	9,950	1.00	2.79
32	20	11,400	10,146	0.89	2.55	11,150	9,924	0.89	2.67	10,850	9,657	0.89	2.85
32	22	12,150	9,356	0.77	2.61	11,900	9,163	0.77	2.76	11,600	8,932	0.77	2.94
34	16	9,900	9,900	1.00	2.42	9,600	9,600	1.00	2.56	9,300	9,300	1.00	2.71
34	18	10,600	10,600	1.00	2.47	10,300	10,300	1.00	2.61	9,950	9,950	1.00	2.79
34	20	11,400	11,058	0.97	2.55	11,150	10,816	0.97	2.67	10,850	10,525	0.97	2.85
34	22	12,150	10,328	0.85	2.61	11,900	10,115	0.85	2.76	11,600	9,860	0.85	2.94

NOTE: CA : Capacity (W) SHC: Sensible heat capacity (W)
P.C.: Power consumption (kW) SHF: Sensible heat factor

COOLING CAPACITY (10)

**PLA-RP4AA.UK PLA-RP4AA₁.UK / PUIZ-RP4VHA
PUIZ-RP4VHA₁**

(230V)

Indoor intake air D.B.(°C)	Indoor intake air W.B.(°C)	Outdoor intake air D.B.(°C)											
		35				40				45			
		CA	SHC	SHF	P.C.	CA	SHC	SHF	P.C.	CA	SHC	SHF	P.C.
20	16	8,900	5,785	0.65	2.91	8,500	5,525	0.65	3.12	8,100	5,265	0.65	3.38
20	18	9,600	5,088	0.53	2.98	9,300	4,929	0.53	3.21	8,700	4,611	0.53	3.45
20	20	10,400	4,264	0.41	3.06	10,000	4,100	0.41	3.27	9,400	3,854	0.41	3.51
22	16	8,900	6,497	0.73	2.91	8,500	6,205	0.73	3.12	8,100	5,913	0.73	3.38
22	18	9,600	5,856	0.61	2.98	9,300	5,673	0.61	3.21	8,700	5,307	0.61	3.45
22	20	10,400	5,096	0.49	3.06	10,000	4,900	0.49	3.27	9,400	4,606	0.49	3.51
24	16	8,900	7,209	0.81	2.91	8,500	6,885	0.81	3.12	8,100	6,561	0.81	3.38
24	18	9,600	6,624	0.69	2.98	9,300	6,417	0.69	3.21	8,700	6,003	0.69	3.45
24	20	10,400	5,928	0.57	3.06	10,000	5,700	0.57	3.27	9,400	5,358	0.57	3.51
24	22	11,200	5,040	0.45	3.12	10,800	4,860	0.45	3.36	10,200	4,590	0.45	3.58
26	16	8,900	7,921	0.89	2.91	8,500	7,565	0.89	3.12	8,100	7,209	0.89	3.38
26	18	9,600	7,392	0.77	2.98	9,300	7,161	0.77	3.21	8,700	6,699	0.77	3.45
26	20	10,400	6,760	0.65	3.06	10,000	6,500	0.65	3.27	9,400	6,110	0.65	3.51
26	22	11,200	5,936	0.53	3.12	10,800	5,724	0.53	3.36	10,200	5,406	0.53	3.58
27	16	8,900	8,277	0.93	2.91	8,500	7,905	0.93	3.12	8,100	7,533	0.93	3.38
27	18	9,600	7,776	0.81	2.98	9,300	7,533	0.81	3.21	8,700	7,047	0.81	3.45
27	20	10,400	7,176	0.69	3.06	10,000	6,900	0.69	3.27	9,400	6,486	0.69	3.51
27	22	11,200	6,384	0.57	3.12	10,800	6,156	0.57	3.36	10,200	5,814	0.57	3.58
28	16	8,900	8,633	0.97	2.91	8,500	8,245	0.97	3.12	8,100	7,857	0.97	3.38
28	18	9,600	8,160	0.85	2.98	9,300	7,905	0.85	3.21	8,700	7,395	0.85	3.45
28	20	10,400	7,592	0.73	3.06	10,000	7,300	0.73	3.27	9,400	6,862	0.73	3.51
28	22	11,200	6,832	0.61	3.12	10,800	6,588	0.61	3.36	10,200	6,222	0.61	3.58
30	16	8,900	8,900	1.00	2.91	8,500	8,500	1.00	3.12	8,100	8,100	1.00	3.38
30	18	9,600	8,928	0.93	2.98	9,300	8,649	0.93	3.21	8,700	8,091	0.93	3.45
30	20	10,400	8,424	0.81	3.06	10,000	8,100	0.81	3.27	9,400	7,614	0.81	3.51
30	22	11,200	7,728	0.69	3.12	10,800	7,452	0.69	3.36	10,200	7,038	0.69	3.58
32	16	8,900	8,900	1.00	2.91	8,500	8,500	1.00	3.12	8,100	8,100	1.00	3.38
32	18	9,600	9,600	1.00	2.98	9,300	9,300	1.00	3.21	8,700	8,700	1.00	3.45
32	20	10,400	9,256	0.89	3.06	10,000	8,900	0.89	3.27	9,400	8,366	0.89	3.51
32	22	11,200	8,624	0.77	3.12	10,800	8,316	0.77	3.36	10,200	7,854	0.77	3.58
34	16	8,900	8,900	1.00	2.91	8,500	8,500	1.00	3.12	8,100	8,100	1.00	3.38
34	18	9,600	9,600	1.00	2.98	9,300	9,300	1.00	3.21	8,700	8,700	1.00	3.45
34	20	10,400	10,088	0.97	3.06	10,000	9,700	0.97	3.27	9,400	9,118	0.97	3.51
34	22	11,200	9,520	0.85	3.12	10,800	9,180	0.85	3.36	10,200	8,670	0.85	3.58

NOTE: CA : Capacity (W) SHC: Sensible heat capacity (W)
P.C.: Power consumption (kW) SHF: Sensible heat factor

COOLING CAPACITY (11)

PLA-RP5AA.UK PLA-RP5AA₁.UK / PUIZ-RP5VHA

PUIZ-RP5VHA₁

(230V)

Indoor intake air D.B.(°C)	Indoor intake air W.B.(°C)	Outdoor intake air D.B.(°C)											
		20				25				30			
		CA	SHC	SHF	P.C.	CA	SHC	SHF	P.C.	CA	SHC	SHF	P.C.
20	16	12,375	7,920	0.64	3.11	12,000	7,680	0.64	3.29	11,625	7,440	0.64	3.48
20	18	13,250	6,890	0.52	3.17	12,875	6,695	0.52	3.35	12,438	6,468	0.52	3.58
20	20	14,250	5,700	0.40	3.27	13,938	5,575	0.40	3.42	13,563	5,425	0.40	3.66
22	16	12,375	8,910	0.72	3.11	12,000	8,640	0.72	3.29	11,625	8,370	0.72	3.48
22	18	13,250	7,950	0.60	3.17	12,875	7,725	0.60	3.35	12,438	7,463	0.60	3.58
22	20	14,250	6,840	0.48	3.27	13,938	6,690	0.48	3.42	13,563	6,510	0.48	3.66
24	16	12,375	9,900	0.80	3.11	12,000	9,600	0.80	3.29	11,625	9,300	0.80	3.48
24	18	13,250	9,010	0.68	3.17	12,875	8,755	0.68	3.35	12,438	8,458	0.68	3.58
24	20	14,250	7,980	0.56	3.27	13,938	7,805	0.56	3.42	13,563	7,595	0.56	3.66
24	22	15,188	6,683	0.44	3.35	14,875	6,545	0.44	3.54	14,500	6,380	0.44	3.77
26	16	12,375	10,890	0.88	3.11	12,000	10,560	0.88	3.29	11,625	10,230	0.88	3.48
26	18	13,250	10,070	0.76	3.17	12,875	9,785	0.76	3.35	12,438	9,453	0.76	3.58
26	20	14,250	9,120	0.64	3.27	13,938	8,920	0.64	3.42	13,563	8,680	0.64	3.66
26	22	15,188	7,898	0.52	3.35	14,875	7,735	0.52	3.54	14,500	7,540	0.52	3.77
27	16	12,375	11,385	0.92	3.11	12,000	11,040	0.92	3.29	11,625	10,695	0.92	3.48
27	18	13,250	10,600	0.80	3.17	12,875	10,300	0.80	3.35	12,438	9,950	0.80	3.58
27	20	14,250	9,690	0.68	3.27	13,938	9,478	0.68	3.42	13,563	9,223	0.68	3.66
27	22	15,188	8,505	0.56	3.35	14,875	8,330	0.56	3.54	14,500	8,120	0.56	3.77
28	16	12,375	11,880	0.96	3.11	12,000	11,520	0.96	3.29	11,625	11,160	0.96	3.48
28	18	13,250	11,130	0.84	3.17	12,875	10,815	0.84	3.35	12,438	10,448	0.84	3.58
28	20	14,250	10,260	0.72	3.27	13,938	10,035	0.72	3.42	13,563	9,765	0.72	3.66
28	22	15,188	9,113	0.60	3.35	14,875	8,925	0.60	3.54	14,500	8,700	0.60	3.77
30	16	12,375	12,375	1.00	3.11	12,000	12,000	1.00	3.29	11,625	11,625	1.00	3.48
30	18	13,250	12,190	0.92	3.17	12,875	11,845	0.92	3.35	12,438	11,443	0.92	3.58
30	20	14,250	11,400	0.80	3.27	13,938	11,150	0.80	3.42	13,563	10,850	0.80	3.66
30	22	15,188	10,328	0.68	3.35	14,875	10,115	0.68	3.54	14,500	9,860	0.68	3.77
32	16	12,375	12,375	1.00	3.11	12,000	12,000	1.00	3.29	11,625	11,625	1.00	3.48
32	18	13,250	13,250	1.00	3.17	12,875	12,875	1.00	3.35	12,438	12,438	1.00	3.58
32	20	14,250	12,540	0.88	3.27	13,938	12,265	0.88	3.42	13,563	11,935	0.88	3.66
32	22	15,188	11,543	0.76	3.35	14,875	11,305	0.76	3.54	14,500	11,020	0.76	3.77
34	16	12,375	12,375	1.00	3.11	12,000	12,000	1.00	3.29	11,625	11,625	1.00	3.48
34	18	13,250	13,250	1.00	3.17	12,875	12,875	1.00	3.35	12,438	12,438	1.00	3.58
34	20	14,250	13,680	0.96	3.27	13,938	13,380	0.96	3.42	13,563	13,020	0.96	3.66
34	22	15,188	12,758	0.84	3.35	14,875	12,495	0.84	3.54	14,500	12,180	0.84	3.77

NOTE: CA : Capacity (W) SHC: Sensible heat capacity (W)
P.C.: Power consumption (kW) SHF: Sensible heat factor

COOLING CAPACITY (12)

**PLA-RP5AA.UK PLA-RP5AA₁.UK / PUIZ-RP5VHA
PUIZ-RP5VHA₁**

(230V)

Indoor intake air D.B.(°C)	Indoor intake air W.B.(°C)	Outdoor intake air D.B.(°C)											
		35				40				45			
		CA	SHC	SHF	P.C.	CA	SHC	SHF	P.C.	CA	SHC	SHF	P.C.
20	16	11,125	7,120	0.64	3.73	10,625	6,800	0.64	4.01	10,125	6,480	0.64	4.34
20	18	12,000	6,240	0.52	3.83	11,625	6,045	0.52	4.12	10,875	5,655	0.52	4.43
20	20	13,000	5,200	0.40	3.93	12,500	5,000	0.40	4.20	11,750	4,700	0.40	4.51
22	16	11,125	8,010	0.72	3.73	10,625	7,650	0.72	4.01	10,125	7,290	0.72	4.34
22	18	12,000	7,200	0.60	3.83	11,625	6,975	0.60	4.12	10,875	6,525	0.60	4.43
22	20	13,000	6,240	0.48	3.93	12,500	6,000	0.48	4.20	11,750	5,640	0.48	4.51
24	16	11,125	8,900	0.80	3.73	10,625	8,500	0.80	4.01	10,125	8,100	0.80	4.34
24	18	12,000	8,160	0.68	3.83	11,625	7,905	0.68	4.12	10,875	7,395	0.68	4.43
24	20	13,000	7,280	0.56	3.93	12,500	7,000	0.56	4.20	11,750	6,580	0.56	4.51
24	22	14,000	6,160	0.44	4.01	13,500	5,940	0.44	4.32	12,750	5,610	0.44	4.59
26	16	11,125	9,790	0.88	3.73	10,625	9,350	0.88	4.01	10,125	8,910	0.88	4.34
26	18	12,000	9,120	0.76	3.83	11,625	8,835	0.76	4.12	10,875	8,265	0.76	4.43
26	20	13,000	8,320	0.64	3.93	12,500	8,000	0.64	4.20	11,750	7,520	0.64	4.51
26	22	14,000	7,280	0.52	4.01	13,500	7,020	0.52	4.32	12,750	6,630	0.52	4.59
27	16	11,125	10,235	0.92	3.73	10,625	9,775	0.92	4.01	10,125	9,315	0.92	4.34
27	18	12,000	9,600	0.80	3.83	11,625	9,300	0.80	4.12	10,875	8,700	0.80	4.43
27	20	13,000	8,840	0.68	3.93	12,500	8,500	0.68	4.20	11,750	7,990	0.68	4.51
27	22	14,000	7,840	0.56	4.01	13,500	7,560	0.56	4.32	12,750	7,140	0.56	4.59
28	16	11,125	10,680	0.96	3.73	10,625	10,200	0.96	4.01	10,125	9,720	0.96	4.34
28	18	12,000	10,080	0.84	3.83	11,625	9,765	0.84	4.12	10,875	9,135	0.84	4.43
28	20	13,000	9,360	0.72	3.93	12,500	9,000	0.72	4.20	11,750	8,460	0.72	4.51
28	22	14,000	8,400	0.60	4.01	13,500	8,100	0.60	4.32	12,750	7,650	0.60	4.59
30	16	11,125	11,125	1.00	3.73	10,625	10,625	1.00	4.01	10,125	10,125	1.00	4.34
30	18	12,000	11,040	0.92	3.83	11,625	10,695	0.92	4.12	10,875	10,005	0.92	4.43
30	20	13,000	10,400	0.80	3.93	12,500	10,000	0.80	4.20	11,750	9,400	0.80	4.51
30	22	14,000	9,520	0.68	4.01	13,500	9,180	0.68	4.32	12,750	8,670	0.68	4.59
32	16	11,125	11,125	1.00	3.73	10,625	10,625	1.00	4.01	10,125	10,125	1.00	4.34
32	18	12,000	12,000	1.00	3.83	11,625	11,625	1.00	4.12	10,875	10,875	1.00	4.43
32	20	13,000	11,440	0.88	3.93	12,500	11,000	0.88	4.20	11,750	10,340	0.88	4.51
32	22	14,000	10,640	0.76	4.01	13,500	10,260	0.76	4.32	12,750	9,690	0.76	4.59
34	16	11,125	11,125	1.00	3.73	10,625	10,625	1.00	4.01	10,125	10,125	1.00	4.34
34	18	12,000	12,000	1.00	3.83	11,625	11,625	1.00	4.12	10,875	10,875	1.00	4.43
34	20	13,000	12,480	0.96	3.93	12,500	12,000	0.96	4.20	11,750	11,280	0.96	4.51
34	22	14,000	11,760	0.84	4.01	13,500	11,340	0.84	4.32	12,750	10,710	0.84	4.59

NOTE: CA : Capacity (W) SHC: Sensible heat capacity (W)
P.C.: Power consumption (kW) SHF: Sensible heat factor

COOLING CAPACITY (13)

PLA-RP6AA.UK PLA-RP6AA₁.UK / PUIHZ-RP6VHA

PUIHZ-RP6VHA₁

(230V)

Indoor intake air D.B.(°C)	Indoor intake air W.B.(°C)	Outdoor intake air D.B.(°C)											
		20				25				30			
		CA	SHC	SHF	P.C.	CA	SHC	SHF	P.C.	CA	SHC	SHF	P.C.
20	16	13,860	8,455	0.61	3.99	13,440	8,198	0.61	4.22	13,020	7,942	0.61	4.47
20	18	14,840	7,272	0.49	4.07	14,420	7,066	0.49	4.29	13,930	6,826	0.49	4.59
20	20	15,960	5,905	0.37	4.19	15,610	5,776	0.37	4.39	15,190	5,620	0.37	4.69
22	16	13,860	9,563	0.69	3.99	13,440	9,274	0.69	4.22	13,020	8,984	0.69	4.47
22	18	14,840	8,459	0.57	4.07	14,420	8,219	0.57	4.29	13,930	7,940	0.57	4.59
22	20	15,960	7,182	0.45	4.19	15,610	7,025	0.45	4.39	15,190	6,836	0.45	4.69
24	16	13,860	10,672	0.77	3.99	13,440	10,349	0.77	4.22	13,020	10,025	0.77	4.47
24	18	14,840	9,646	0.65	4.07	14,420	9,373	0.65	4.29	13,930	9,055	0.65	4.59
24	20	15,960	8,459	0.53	4.19	15,610	8,273	0.53	4.39	15,190	8,051	0.53	4.69
24	22	17,010	6,974	0.41	4.29	16,660	6,831	0.41	4.54	16,240	6,658	0.41	4.84
26	16	13,860	11,781	0.85	3.99	13,440	11,424	0.85	4.22	13,020	11,067	0.85	4.47
26	18	14,840	10,833	0.73	4.07	14,420	10,527	0.73	4.29	13,930	10,169	0.73	4.59
26	20	15,960	9,736	0.61	4.19	15,610	9,522	0.61	4.39	15,190	9,266	0.61	4.69
26	22	17,010	8,335	0.49	4.29	16,660	8,163	0.49	4.54	16,240	7,958	0.49	4.84
27	16	13,860	12,335	0.89	3.99	13,440	11,962	0.89	4.22	13,020	11,588	0.89	4.47
27	18	14,840	11,427	0.77	4.07	14,420	11,103	0.77	4.29	13,930	10,726	0.77	4.59
27	20	15,960	10,374	0.65	4.19	15,610	10,147	0.65	4.39	15,190	9,874	0.65	4.69
27	22	17,010	9,015	0.53	4.29	16,660	8,830	0.53	4.54	16,240	8,607	0.53	4.84
28	16	13,860	12,890	0.93	3.99	13,440	12,499	0.93	4.22	13,020	12,109	0.93	4.47
28	18	14,840	12,020	0.81	4.07	14,420	11,680	0.81	4.29	13,930	11,283	0.81	4.59
28	20	15,960	11,012	0.69	4.19	15,610	10,771	0.69	4.39	15,190	10,481	0.69	4.69
28	22	17,010	9,696	0.57	4.29	16,660	9,496	0.57	4.54	16,240	9,257	0.57	4.84
30	16	13,860	13,860	1.00	3.99	13,440	13,440	1.00	4.22	13,020	13,020	1.00	4.47
30	18	14,840	13,208	0.89	4.07	14,420	12,834	0.89	4.29	13,930	12,398	0.89	4.59
30	20	15,960	12,289	0.77	4.19	15,610	12,020	0.77	4.39	15,190	11,696	0.77	4.69
30	22	17,010	11,057	0.65	4.29	16,660	10,829	0.65	4.54	16,240	10,556	0.65	4.84
32	16	13,860	13,860	1.00	3.99	13,440	13,440	1.00	4.22	13,020	13,020	1.00	4.47
32	18	14,840	14,395	0.97	4.07	14,420	13,987	0.97	4.29	13,930	13,512	0.97	4.59
32	20	15,960	13,566	0.85	4.19	15,610	13,269	0.85	4.39	15,190	12,912	0.85	4.69
32	22	17,010	12,417	0.73	4.29	16,660	12,162	0.73	4.54	16,240	11,855	0.73	4.84
34	16	13,860	13,860	1.00	3.99	13,440	13,440	1.00	4.22	13,020	13,020	1.00	4.47
34	18	14,840	14,840	1.00	4.07	14,420	14,420	1.00	4.29	13,930	13,930	1.00	4.59
34	20	15,960	14,843	0.93	4.19	15,610	14,517	0.93	4.39	15,190	14,127	0.93	4.69
34	22	17,010	13,778	0.81	4.29	16,660	13,495	0.81	4.54	16,240	13,154	0.81	4.84

NOTE: CA : Capacity (W) SHC: Sensible heat capacity (W)
P.C.: Power consumption (kW) SHF: Sensible heat factor

COOLING CAPACITY (14)

**PLA-RP6AA.UK PLA-RP6AA₁.UK / PUIHZ-RP6VHA
PUIHZ-RP6VHA₁**

(230V)

Indoor intake air D.B.(°C)	Indoor intake air W.B.(°C)	Outdoor intake air D.B.(°C)											
		35				40				45			
		CA	SHC	SHF	P.C.	CA	SHC	SHF	P.C.	CA	SHC	SHF	P.C.
20	16	12,460	7,601	0.61	4.79	11,900	7,259	0.61	5.14	11,340	6,917	0.61	5.56
20	18	13,440	6,586	0.49	4.92	13,020	6,380	0.49	5.29	12,180	5,968	0.49	5.69
20	20	14,560	5,387	0.37	5.04	14,000	5,180	0.37	5.39	13,160	4,869	0.37	5.79
22	16	12,460	8,597	0.69	4.79	11,900	8,211	0.69	5.14	11,340	7,825	0.69	5.56
22	18	13,440	7,661	0.57	4.92	13,020	7,421	0.57	5.29	12,180	6,943	0.57	5.69
22	20	14,560	6,552	0.45	5.04	14,000	6,300	0.45	5.39	13,160	5,922	0.45	5.79
24	16	12,460	9,594	0.77	4.79	11,900	9,163	0.77	5.14	11,340	8,732	0.77	5.56
24	18	13,440	8,736	0.65	4.92	13,020	8,463	0.65	5.29	12,180	7,917	0.65	5.69
24	20	14,560	7,717	0.53	5.04	14,000	7,420	0.53	5.39	13,160	6,975	0.53	5.79
24	22	15,680	6,429	0.41	5.14	15,120	6,199	0.41	5.54	14,280	5,855	0.41	5.89
26	16	12,460	10,591	0.85	4.79	11,900	10,115	0.85	5.14	11,340	9,639	0.85	5.56
26	18	13,440	9,811	0.73	4.92	13,020	9,505	0.73	5.29	12,180	8,891	0.73	5.69
26	20	14,560	8,882	0.61	5.04	14,000	8,540	0.61	5.39	13,160	8,028	0.61	5.79
26	22	15,680	7,683	0.49	5.14	15,120	7,409	0.49	5.54	14,280	6,997	0.49	5.89
27	16	12,460	11,089	0.89	4.79	11,900	10,591	0.89	5.14	11,340	10,093	0.89	5.56
27	18	13,440	10,349	0.77	4.92	13,020	10,025	0.77	5.29	12,180	9,379	0.77	5.69
27	20	14,560	9,464	0.65	5.04	14,000	9,100	0.65	5.39	13,160	8,554	0.65	5.79
27	22	15,680	8,310	0.53	5.14	15,120	8,014	0.53	5.54	14,280	7,568	0.53	5.89
28	16	12,460	11,588	0.93	4.79	11,900	11,067	0.93	5.14	11,340	10,546	0.93	5.56
28	18	13,440	10,886	0.81	4.92	13,020	10,546	0.81	5.29	12,180	9,866	0.81	5.69
28	20	14,560	10,046	0.69	5.04	14,000	9,660	0.69	5.39	13,160	9,080	0.69	5.79
28	22	15,680	8,938	0.57	5.14	15,120	8,618	0.57	5.54	14,280	8,140	0.57	5.89
30	16	12,460	12,460	1.00	4.79	11,900	11,900	1.00	5.14	11,340	11,340	1.00	5.56
30	18	13,440	11,962	0.89	4.92	13,020	11,588	0.89	5.29	12,180	10,840	0.89	5.69
30	20	14,560	11,211	0.77	5.04	14,000	10,780	0.77	5.39	13,160	10,133	0.77	5.79
30	22	15,680	10,192	0.65	5.14	15,120	9,828	0.65	5.54	14,280	9,282	0.65	5.89
32	16	12,460	12,460	1.00	4.79	11,900	11,900	1.00	5.14	11,340	11,340	1.00	5.56
32	18	13,440	13,037	0.97	4.92	13,020	12,629	0.97	5.29	12,180	11,815	0.97	5.69
32	20	14,560	12,376	0.85	5.04	14,000	11,900	0.85	5.39	13,160	11,186	0.85	5.79
32	22	15,680	11,446	0.73	5.14	15,120	11,038	0.73	5.54	14,280	10,424	0.73	5.89
34	16	12,460	12,460	1.00	4.79	11,900	11,900	1.00	5.14	11,340	11,340	1.00	5.56
34	18	13,440	13,440	1.00	4.92	13,020	13,020	1.00	5.29	12,180	12,180	1.00	5.69
34	20	14,560	13,541	0.93	5.04	14,000	13,020	0.93	5.39	13,160	12,239	0.93	5.79
34	22	15,680	12,701	0.81	5.14	15,120	12,247	0.81	5.54	14,280	11,567	0.81	5.89

NOTE: CA : Capacity (W) SHC: Sensible heat capacity (W)
P.C.: Power consumption (kW) SHF: Sensible heat factor

COOLING CAPACITY (16)

**PLA-RP1.6AA.UK / PUH-P1.6VGAA.UK PUH-P1.6YGAA.UK
 PUH-P1.6VGAA₁.UK PUH-P1.6YGAA₁.UK
 PU-P1.6VGAA.UK PU-P1.6YGAA.UK
 PU-P1.6VGAA₁.UK PU-P1.6YGAA₁.UK**

(230V)

Indoor intake air D.B.(°C)	Indoor intake air W.B.(°C)	Outdoor intake air D.B.(°C)											
		35				40				45			
		CA	SHC	SHF	P.C.	CA	SHC	SHF	P.C.	CA	SHC	SHF	P.C.
20	16	4005	2603	0.65	1.65	3825	2486	0.65	1.77	3645	2369	0.65	1.92
20	18	4320	2290	0.53	1.69	4185	2218	0.53	1.82	3915	2075	0.53	1.96
20	20	4680	1919	0.41	1.74	4500	1845	0.41	1.86	4230	1734	0.41	2.00
22	16	4005	2924	0.73	1.65	3825	2792	0.73	1.77	3645	2661	0.73	1.92
22	18	4320	2635	0.61	1.69	4185	2553	0.61	1.82	3915	2388	0.61	1.96
22	20	4680	2293	0.49	1.74	4500	2205	0.49	1.86	4230	2073	0.49	2.00
24	16	4005	3244	0.81	1.65	3825	3098	0.81	1.77	3645	2952	0.81	1.92
24	18	4320	2981	0.69	1.69	4185	2888	0.69	1.82	3915	2701	0.69	1.96
24	20	4680	2668	0.57	1.74	4500	2565	0.57	1.86	4230	2411	0.57	2.00
24	22	5040	2268	0.45	1.77	4860	2187	0.45	1.91	4590	2066	0.45	2.03
26	16	4005	3564	0.89	1.65	3825	3404	0.89	1.77	3645	3244	0.89	1.92
26	18	4320	3326	0.77	1.69	4185	3222	0.77	1.82	3915	3015	0.77	1.96
26	20	4680	3042	0.65	1.74	4500	2925	0.65	1.86	4230	2750	0.65	2.00
26	22	5040	2671	0.53	1.77	4860	2576	0.53	1.91	4590	2433	0.53	2.03
27	16	4005	3725	0.93	1.65	3825	3557	0.93	1.77	3645	3390	0.93	1.92
27	18	4320	3499	0.81	1.69	4185	3390	0.81	1.82	3915	3171	0.81	1.96
27	20	4680	3229	0.69	1.74	4500	3105	0.69	1.86	4230	2919	0.69	2.00
27	22	5040	2873	0.57	1.77	4860	2770	0.57	1.91	4590	2616	0.57	2.03
28	16	4005	3885	0.97	1.65	3825	3710	0.97	1.77	3645	3536	0.97	1.92
28	18	4320	3672	0.85	1.69	4185	3557	0.85	1.82	3915	3328	0.85	1.96
28	20	4680	3416	0.73	1.74	4500	3285	0.73	1.86	4230	3088	0.73	2.00
28	22	5040	3074	0.61	1.77	4860	2965	0.61	1.91	4590	2800	0.61	2.03
30	16	4005	4005	1.00	1.65	3825	3825	1.00	1.77	3645	3645	1.00	1.92
30	18	4320	4018	0.93	1.69	4185	3892	0.93	1.82	3915	3641	0.93	1.96
30	20	4680	3791	0.81	1.74	4500	3645	0.81	1.86	4230	3426	0.81	2.00
30	22	5040	3478	0.69	1.77	4860	3353	0.69	1.91	4590	3167	0.69	2.03
32	16	4005	4005	1.00	1.65	3825	3825	1.00	1.77	3645	3645	1.00	1.92
32	18	4320	4320	1.00	1.69	4185	4185	1.00	1.82	3915	3915	1.00	1.96
32	20	4680	4165	0.89	1.74	4500	4005	0.89	1.86	4230	3765	0.89	2.00
32	22	5040	3881	0.77	1.77	4860	3742	0.77	1.91	4590	3534	0.77	2.03
34	16	4005	4005	1.00	1.65	3825	3825	1.00	1.77	3645	3645	1.00	1.92
34	18	4320	4320	1.00	1.69	4185	4185	1.00	1.82	3915	3915	1.00	1.96
34	20	4680	4540	0.97	1.74	4500	4365	0.97	1.86	4230	4103	0.97	2.00
34	22	5040	4284	0.85	1.77	4860	4131	0.85	1.91	4590	3902	0.85	2.03

NOTE: CA : Capacity (W) SHC: Sensible heat capacity (W)
 P.C.: Power consumption (kW) SHF: Sensible heat factor

COOLING CAPACITY (17)

PLA-RP2AA.UK / PUH-P2VGAA.UK PUH-P2YGAA.UK
PUH-P2VGAA₁.UK PUH-P2YGAA₁.UK
PU-P2VGAA.UK PU-P2YGAA.UK
PU-P2VGAA₁.UK PU-P2YGAA₁.UK

(230V)

Indoor intake air D.B.(°C)	Indoor intake air W.B.(°C)	Outdoor intale air D.B.(°C)											
		20				25				30			
		CA	SHC	SHF	P.C.	CA	SHC	SHF	P.C.	CA	SHC	SHF	P.C.
20	16	5544	3992	0.72	2.02	5376	3871	0.72	2.14	5208	3750	0.72	2.26
20	18	5936	3562	0.60	2.06	5768	3461	0.60	2.18	5572	3343	0.60	2.33
20	20	6384	3064	0.48	2.13	6244	2997	0.48	2.23	6076	2916	0.48	2.38
22	16	5544	4435	0.80	2.02	5376	4301	0.80	2.14	5208	4166	0.80	2.26
22	18	5936	4036	0.68	2.06	5768	3922	0.68	2.18	5572	3789	0.68	2.33
22	20	6384	3575	0.56	2.13	6244	3497	0.56	2.23	6076	3403	0.56	2.38
24	16	5544	4879	0.88	2.02	5376	4731	0.88	2.14	5208	4583	0.88	2.26
24	18	5936	4511	0.76	2.06	5768	4384	0.76	2.18	5572	4235	0.76	2.33
24	20	6384	4086	0.64	2.13	6244	3996	0.64	2.23	6076	3889	0.64	2.38
24	22	6804	3538	0.52	2.18	6664	3465	0.52	2.30	6496	3378	0.52	2.45
26	16	5544	5322	0.96	2.02	5376	5161	0.96	2.14	5208	5000	0.96	2.26
26	18	5936	4986	0.84	2.06	5768	4845	0.84	2.18	5572	4680	0.84	2.33
26	20	6384	4596	0.72	2.13	6244	4496	0.72	2.23	6076	4375	0.72	2.38
26	22	6804	4082	0.60	2.18	6664	3998	0.60	2.30	6496	3898	0.60	2.45
27	16	5544	5544	1.00	2.02	5376	5376	1.00	2.14	5208	5208	1.00	2.26
27	18	5936	5224	0.88	2.06	5768	5076	0.88	2.18	5572	4903	0.88	2.33
27	20	6384	4852	0.76	2.13	6244	4745	0.76	2.23	6076	4618	0.76	2.38
27	22	6804	4355	0.64	2.18	6664	4265	0.64	2.30	6496	4157	0.64	2.45
28	16	5544	5544	1.00	2.02	5376	5376	1.00	2.14	5208	5208	1.00	2.26
28	18	5936	5461	0.92	2.06	5768	5307	0.92	2.18	5572	5126	0.92	2.33
28	20	6384	5107	0.80	2.13	6244	4995	0.80	2.23	6076	4861	0.80	2.38
28	22	6804	4627	0.68	2.18	6664	4532	0.68	2.30	6496	4417	0.68	2.45
30	16	5544	5544	1.00	2.02	5376	5376	1.00	2.14	5208	5208	1.00	2.26
30	18	5936	5936	1.00	2.06	5768	5768	1.00	2.18	5572	5572	1.00	2.33
30	20	6384	5618	0.88	2.13	6244	5495	0.88	2.23	6076	5347	0.88	2.38
30	22	6804	5171	0.76	2.18	6664	5065	0.76	2.30	6496	4937	0.76	2.45
32	16	5544	5544	1.00	2.02	5376	5376	1.00	2.14	5208	5208	1.00	2.26
32	18	5936	5936	1.00	2.06	5768	5768	1.00	2.18	5572	5572	1.00	2.33
32	20	6384	6129	0.96	2.13	6244	5994	0.96	2.23	6076	5833	0.96	2.38
32	22	6804	5715	0.84	2.18	6664	5598	0.84	2.30	6496	5457	0.84	2.45
34	16	5544	5544	1.00	2.02	5376	5376	1.00	2.14	5208	5208	1.00	2.26
34	18	5936	5936	1.00	2.06	5768	5768	1.00	2.18	5572	5572	1.00	2.33
34	20	6384	6384	1.00	2.13	6244	6244	1.00	2.23	6076	6076	1.00	2.38
34	22	6804	6260	0.92	2.18	6664	6131	0.92	2.30	6496	5976	0.92	2.45

NOTE: CA : Capacity (W) SHC: Sensible heat capacity (W)
P.C.: Power consumption (kW) SHF: Sensible heat factor

COOLING CAPACITY (18)

PLA-RP2AA.UK / PUH-P2VGAA.UK PUH-P2YGAA.UK
PUH-P2VGAA₁.UK PUH-P2YGAA₁.UK
PU-P2VGAA.UK PU-P2YGAA.UK
PU-P2VGAA₁.UK PU-P2YGAA₁.UK

(230V)

Indoor intake air D.B.(°C)	Indoor intake air W.B.(°C)	Outdoor intake air D.B.(°C)											
		35				40				45			
		CA	SHC	SHF	P.C.	CA	SHC	SHF	P.C.	CA	SHC	SHF	P.C.
20	16	4984	3588	0.72	2.43	4760	3427	0.72	2.61	4536	3266	0.72	2.82
20	18	5376	3226	0.60	2.49	5208	3125	0.60	2.68	4872	2923	0.60	2.88
20	20	5824	2796	0.48	2.56	5600	2688	0.48	2.73	5264	2527	0.48	2.93
22	16	4984	3987	0.80	2.43	4760	3808	0.80	2.61	4536	3629	0.80	2.82
22	18	5376	3656	0.68	2.49	5208	3541	0.68	2.68	4872	3313	0.68	2.88
22	20	5824	3261	0.56	2.56	5600	3136	0.56	2.73	5264	2948	0.56	2.93
24	16	4984	4386	0.88	2.43	4760	4189	0.88	2.61	4536	3992	0.88	2.82
24	18	5376	4086	0.76	2.49	5208	3958	0.76	2.68	4872	3703	0.76	2.88
24	20	5824	3727	0.64	2.56	5600	3584	0.64	2.73	5264	3369	0.64	2.93
24	22	6272	3261	0.52	2.61	6048	3145	0.52	2.81	5712	2970	0.52	2.99
26	16	4984	4785	0.96	2.43	4760	4570	0.96	2.61	4536	4355	0.96	2.82
26	18	5376	4516	0.84	2.49	5208	4375	0.84	2.68	4872	4092	0.84	2.88
26	20	5824	4193	0.72	2.56	5600	4032	0.72	2.73	5264	3790	0.72	2.93
26	22	6272	3763	0.60	2.61	6048	3629	0.60	2.81	5712	3427	0.60	2.99
27	16	4984	4984	1.00	2.43	4760	4760	1.00	2.61	4536	4536	1.00	2.82
27	18	5376	4731	0.88	2.49	5208	4583	0.88	2.68	4872	4287	0.88	2.88
27	20	5824	4426	0.76	2.56	5600	4256	0.76	2.73	5264	4001	0.76	2.93
27	22	6272	4014	0.64	2.61	6048	3871	0.64	2.81	5712	3656	0.64	2.99
28	16	4984	4984	1.00	2.43	4760	4760	1.00	2.61	4536	4536	1.00	2.82
28	18	5376	4946	0.92	2.49	5208	4791	0.92	2.68	4872	4482	0.92	2.88
28	20	5824	4659	0.80	2.56	5600	4480	0.80	2.73	5264	4211	0.80	2.93
28	22	6272	4265	0.68	2.61	6048	4113	0.68	2.81	5712	3884	0.68	2.99
30	16	4984	4984	1.00	2.43	4760	4760	1.00	2.61	4536	4536	1.00	2.82
30	18	5376	5376	1.00	2.49	5208	5208	1.00	2.68	4872	4872	1.00	2.88
30	20	5824	5125	0.88	2.56	5600	4928	0.88	2.73	5264	4632	0.88	2.93
30	22	6272	4767	0.76	2.61	6048	4596	0.76	2.81	5712	4341	0.76	2.99
32	16	4984	4984	1.00	2.43	4760	4760	1.00	2.61	4536	4536	1.00	2.82
32	18	5376	5376	1.00	2.49	5208	5208	1.00	2.68	4872	4872	1.00	2.88
32	20	5824	5591	0.96	2.56	5600	5376	0.96	2.73	5264	5053	0.96	2.93
32	22	6272	5268	0.84	2.61	6048	5080	0.84	2.81	5712	4798	0.84	2.99
34	16	4984	4984	1.00	2.43	4760	4760	1.00	2.61	4536	4536	1.00	2.82
34	18	5376	5376	1.00	2.49	5208	5208	1.00	2.68	4872	4872	1.00	2.88
34	20	5824	5824	1.00	2.56	5600	5600	1.00	2.73	5264	5264	1.00	2.93
34	22	6272	5770	0.92	2.61	6048	5564	0.92	2.81	5712	5255	0.92	2.99

NOTE: CA : Capacity (W) SHC: Sensible heat capacity (W)
P.C.: Power consumption (kW) SHF: Sensible heat factor

COOLING CAPACITY (19)

PLA-RP2.5AA.UK / PUH-P2.5VGAA.UK PUH-P2.5YGAA.UK
PUH-P2.5VGAA₁.UK PUH-P2.5YGAA₁.UK
PU-P2.5VGAA.UK PU-P2.5YGAA.UK
PU-P2.5VGAA₁.UK PU-P2.5YGAA₁.UK

(230V)

Indoor intake air D.B.(°C)	Indoor intake air W.B.(°C)	Outdoor intake air D.B.(°C)											
		20				25				30			
		CA	SHC	SHF	P.C.	CA	SHC	SHF	P.C.	CA	SHC	SHF	P.C.
20	16	6633	4112	0.62	2.06	6432	3988	0.62	2.17	6231	3863	0.62	2.30
20	18	7102	3551	0.50	2.09	6901	3451	0.50	2.21	6667	3333	0.50	2.36
20	20	7638	2902	0.38	2.16	7471	2839	0.38	2.26	7270	2762	0.38	2.42
22	16	6633	4643	0.70	2.06	6432	4502	0.70	2.17	6231	4362	0.70	2.30
22	18	7102	4119	0.58	2.09	6901	4003	0.58	2.21	6667	3867	0.58	2.36
22	20	7638	3513	0.46	2.16	7471	3436	0.46	2.26	7270	3344	0.46	2.42
24	16	6633	5174	0.78	2.06	6432	5017	0.78	2.17	6231	4860	0.78	2.30
24	18	7102	4687	0.66	2.09	6901	4555	0.66	2.21	6667	4400	0.66	2.36
24	20	7638	4125	0.54	2.16	7471	4034	0.54	2.26	7270	3926	0.54	2.42
24	22	8141	3419	0.42	2.21	7973	3349	0.42	2.34	7772	3264	0.42	2.49
26	16	6633	5704	0.86	2.06	6432	5532	0.86	2.17	6231	5359	0.86	2.30
26	18	7102	5255	0.74	2.09	6901	5107	0.74	2.21	6667	4933	0.74	2.36
26	20	7638	4736	0.62	2.16	7471	4632	0.62	2.26	7270	4507	0.62	2.42
26	22	8141	4070	0.50	2.21	7973	3987	0.50	2.34	7772	3886	0.50	2.49
27	16	6633	5970	0.90	2.06	6432	5789	0.90	2.17	6231	5608	0.90	2.30
27	18	7102	5540	0.78	2.09	6901	5383	0.78	2.21	6667	5200	0.78	2.36
27	20	7638	5041	0.66	2.16	7471	4931	0.66	2.26	7270	4798	0.66	2.42
27	22	8141	4396	0.54	2.21	7973	4305	0.54	2.34	7772	4197	0.54	2.49
28	16	6633	6235	0.94	2.06	6432	6046	0.94	2.17	6231	5857	0.94	2.30
28	18	7102	5824	0.82	2.09	6901	5659	0.82	2.21	6667	5467	0.82	2.36
28	20	7638	5347	0.70	2.16	7471	5229	0.70	2.26	7270	5089	0.70	2.42
28	22	8141	4721	0.58	2.21	7973	4624	0.58	2.34	7772	4508	0.58	2.49
30	16	6633	6633	1.00	2.06	6432	6432	1.00	2.17	6231	6231	1.00	2.30
30	18	7102	6392	0.90	2.09	6901	6211	0.90	2.21	6667	6000	0.90	2.36
30	20	7638	5958	0.78	2.16	7471	5827	0.78	2.26	7270	5670	0.78	2.42
30	22	8141	5373	0.66	2.21	7973	5262	0.66	2.34	7772	5130	0.66	2.49
32	16	6633	6633	1.00	2.06	6432	6432	1.00	2.17	6231	6231	1.00	2.30
32	18	7102	6960	0.98	2.09	6901	6763	0.98	2.21	6667	6533	0.98	2.36
32	20	7638	6569	0.86	2.16	7471	6425	0.86	2.26	7270	6252	0.86	2.42
32	22	8141	6024	0.74	2.21	7973	5900	0.74	2.34	7772	5751	0.74	2.49
34	16	6633	6633	1.00	2.06	6432	6432	1.00	2.17	6231	6231	1.00	2.30
34	18	7102	7102	1.00	2.09	6901	6901	1.00	2.21	6667	6667	1.00	2.36
34	20	7638	7180	0.94	2.16	7471	7022	0.94	2.26	7270	6833	0.94	2.42
34	22	8141	6675	0.82	2.21	7973	6538	0.82	2.34	7772	6373	0.82	2.49

NOTE: CA : Capacity (W) SHC: Sensible heat capacity (W)
P.C.: Power consumption (kW) SHF: Sensible heat factor

COOLING CAPACITY (20)

PLA-RP2.5AA.UK / PUH-P2.5VGAA.UK PUH-P2.5YGAA.UK
PUH-P2.5VGAA₁.UK PUH-P2.5YGAA₁.UK
PU-P2.5VGAA.UK PU-P2.5YGAA.UK
PU-P2.5VGAA₁.UK PU-P2.5YGAA₁.UK

(230V)

Indoor intake air D.B.(°C)	Indoor intake air W.B.(°C)	Outdoor intake air D.B.(°C)											
		35				40				45			
		CA	SHC	SHF	P.C.	CA	SHC	SHF	P.C.	CA	SHC	SHF	P.C.
20	16	5963	3697	0.62	2.47	5695	3531	0.62	2.65	5427	3365	0.62	2.87
20	18	6432	3216	0.50	2.53	6231	3116	0.50	2.72	5829	2915	0.50	2.93
20	20	6968	2648	0.38	2.60	6700	2546	0.38	2.78	6298	2393	0.38	2.98
22	16	5963	4174	0.70	2.47	5695	3987	0.70	2.65	5427	3799	0.70	2.87
22	18	6432	3731	0.58	2.53	6231	3614	0.58	2.72	5829	3381	0.58	2.93
22	20	6968	3205	0.46	2.60	6700	3082	0.46	2.78	6298	2897	0.46	2.98
24	16	5963	4651	0.78	2.47	5695	4442	0.78	2.65	5427	4233	0.78	2.87
24	18	6432	4245	0.66	2.53	6231	4112	0.66	2.72	5829	3847	0.66	2.93
24	20	6968	3763	0.54	2.60	6700	3618	0.54	2.78	6298	3401	0.54	2.98
24	22	7504	3152	0.42	2.65	7236	3039	0.42	2.85	6834	2870	0.42	3.03
26	16	5963	5128	0.86	2.47	5695	4898	0.86	2.65	5427	4667	0.86	2.87
26	18	6432	4760	0.74	2.53	6231	4611	0.74	2.72	5829	4313	0.74	2.93
26	20	6968	4320	0.62	2.60	6700	4154	0.62	2.78	6298	3905	0.62	2.98
26	22	7504	3752	0.50	2.65	7236	3618	0.50	2.85	6834	3417	0.50	3.03
27	16	5963	5367	0.90	2.47	5695	5126	0.90	2.65	5427	4884	0.90	2.87
27	18	6432	5017	0.78	2.53	6231	4860	0.78	2.72	5829	4547	0.78	2.93
27	20	6968	4599	0.66	2.60	6700	4422	0.66	2.78	6298	4157	0.66	2.98
27	22	7504	4052	0.54	2.65	7236	3907	0.54	2.85	6834	3690	0.54	3.03
28	16	5963	5605	0.94	2.47	5695	5353	0.94	2.65	5427	5101	0.94	2.87
28	18	6432	5274	0.82	2.53	6231	5109	0.82	2.72	5829	4780	0.82	2.93
28	20	6968	4878	0.70	2.60	6700	4690	0.70	2.78	6298	4409	0.70	2.98
28	22	7504	4352	0.58	2.65	7236	4197	0.58	2.85	6834	3964	0.58	3.03
30	16	5963	5963	1.00	2.47	5695	5695	1.00	2.65	5427	5427	1.00	2.87
30	18	6432	5789	0.90	2.53	6231	5608	0.90	2.72	5829	5246	0.90	2.93
30	20	6968	5435	0.78	2.60	6700	5226	0.78	2.78	6298	4912	0.78	2.98
30	22	7504	4953	0.66	2.65	7236	4776	0.66	2.85	6834	4510	0.66	3.03
32	16	5963	5963	1.00	2.47	5695	5695	1.00	2.65	5427	5427	1.00	2.87
32	18	6432	6303	0.98	2.53	6231	6106	0.98	2.72	5829	5712	0.98	2.93
32	20	6968	5992	0.86	2.60	6700	5762	0.86	2.78	6298	5416	0.86	2.98
32	22	7504	5553	0.74	2.65	7236	5355	0.74	2.85	6834	5057	0.74	3.03
34	16	5963	5963	1.00	2.47	5695	5695	1.00	2.65	5427	5427	1.00	2.87
34	18	6432	6432	1.00	2.53	6231	6231	1.00	2.72	5829	5829	1.00	2.93
34	20	6968	6550	0.94	2.60	6700	6298	0.94	2.78	6298	5920	0.94	2.98
34	22	7504	6153	0.82	2.65	7236	5934	0.82	2.85	6834	5604	0.82	3.03

NOTE: CA : Capacity (W) SHC: Sensible heat capacity (W)
P.C.: Power consumption (kW) SHF: Sensible heat factor

COOLING CAPACITY (21)

PLA-RP3AA.UK PLA-RP3AA₁.UK / PUH-P3VGAA.UK PUH-P3YGAA.UK
PUH-P3VGAA₁.UK PUH-P3YGAA₁.UK
PU-P3VGAA.UK PU-P3YGAA.UK
PU-P3VGAA₁.UK PU-P3YGAA₁.UK

(230V)

Indoor intake air D.B.(°C)	Indoor intake air W.B.(°C)	Outdoor intale air D.B.(°C)											
		20				25				30			
		CA	SHC	SHF	P.C.	CA	SHC	SHF	P.C.	CA	SHC	SHF	P.C.
20	16	7623	4879	0.64	2.74	7392	4731	0.64	2.89	7161	4583	0.64	3.06
20	18	8162	4244	0.52	2.79	7931	4124	0.52	2.94	7662	3984	0.52	3.15
20	20	8778	3511	0.40	2.87	8586	3434	0.40	3.01	8355	3342	0.40	3.21
22	16	7623	5489	0.72	2.74	7392	5322	0.72	2.89	7161	5156	0.72	3.06
22	18	8162	4897	0.60	2.79	7931	4759	0.60	2.94	7662	4597	0.60	3.15
22	20	8778	4213	0.48	2.87	8586	4121	0.48	3.01	8355	4010	0.48	3.21
24	16	7623	6098	0.80	2.74	7392	5914	0.80	2.89	7161	5729	0.80	3.06
24	18	8162	5550	0.68	2.79	7931	5393	0.68	2.94	7662	5210	0.68	3.15
24	20	8778	4916	0.56	2.87	8586	4808	0.56	3.01	8355	4679	0.56	3.21
24	22	9356	4116	0.44	2.94	9163	4032	0.44	3.11	8932	3930	0.44	3.32
26	16	7623	6708	0.88	2.74	7392	6505	0.88	2.89	7161	6302	0.88	3.06
26	18	8162	6203	0.76	2.79	7931	6028	0.76	2.94	7662	5823	0.76	3.15
26	20	8778	5618	0.64	2.87	8586	5495	0.64	3.01	8355	5347	0.64	3.21
26	22	9356	4865	0.52	2.94	9163	4765	0.52	3.11	8932	4645	0.52	3.32
27	16	7623	7013	0.92	2.74	7392	6801	0.92	2.89	7161	6588	0.92	3.06
27	18	8162	6530	0.80	2.79	7931	6345	0.80	2.94	7662	6129	0.80	3.15
27	20	8778	5969	0.68	2.87	8586	5838	0.68	3.01	8355	5681	0.68	3.21
27	22	9356	5239	0.56	2.94	9163	5131	0.56	3.11	8932	5002	0.56	3.32
28	16	7623	7318	0.96	2.74	7392	7096	0.96	2.89	7161	6875	0.96	3.06
28	18	8162	6856	0.84	2.79	7931	6662	0.84	2.94	7662	6436	0.84	3.15
28	20	8778	6320	0.72	2.87	8586	6182	0.72	3.01	8355	6015	0.72	3.21
28	22	9356	5613	0.60	2.94	9163	5498	0.60	3.11	8932	5359	0.60	3.32
30	16	7623	7623	1.00	2.74	7392	7392	1.00	2.89	7161	7161	1.00	3.06
30	18	8162	7509	0.92	2.79	7931	7297	0.92	2.94	7662	7049	0.92	3.15
30	20	8778	7022	0.80	2.87	8586	6868	0.80	3.01	8355	6684	0.80	3.21
30	22	9356	6362	0.68	2.94	9163	6231	0.68	3.11	8932	6074	0.68	3.32
32	16	7623	7623	1.00	2.74	7392	7392	1.00	2.89	7161	7161	1.00	3.06
32	18	8162	8162	1.00	2.79	7931	7931	1.00	2.94	7662	7662	1.00	3.15
32	20	8778	7725	0.88	2.87	8586	7555	0.88	3.01	8355	7352	0.88	3.21
32	22	9356	7110	0.76	2.94	9163	6964	0.76	3.11	8932	6788	0.76	3.32
34	16	7623	7623	1.00	2.74	7392	7392	1.00	2.89	7161	7161	1.00	3.06
34	18	8162	8162	1.00	2.79	7931	7931	1.00	2.94	7662	7662	1.00	3.15
34	20	8778	8427	0.96	2.87	8586	8242	0.96	3.01	8355	8020	0.96	3.21
34	22	9356	7859	0.84	2.94	9163	7697	0.84	3.11	8932	7503	0.84	3.32

NOTE: CA : Capacity (W) SHC: Sensible heat capacity (W)
P.C.: Power consumption (kW) SHF: Sensible heat factor

COOLING CAPACITY (22)

PLA-RP3AA.UK PLA-RP3AA₁.UK / PUH-P3VGAA.UK PUH-P3YGAA.UK
PUH-P3VGAA₁.UK PUH-P3YGAA₁.UK
PU-P3VGAA.UK PU-P3YGAA.UK
PU-P3VGAA₁.UK PU-P3YGAA₁.UK

(230V)

Indoor intake air D.B.(°C)	Indoor intake air W.B.(°C)	Outdoor intake air D.B.(°C)											
		35				40				45			
		CA	SHC	SHF	P.C.	CA	SHC	SHF	P.C.	CA	SHC	SHF	P.C.
20	16	6853	4386	0.64	3.28	6545	4189	0.64	3.52	6237	3992	0.64	3.81
20	18	7392	3844	0.52	3.37	7161	3724	0.52	3.63	6699	3483	0.52	3.90
20	20	8008	3203	0.40	3.45	7700	3080	0.40	3.69	7238	2895	0.40	3.97
22	16	6853	4934	0.72	3.28	6545	4712	0.72	3.52	6237	4491	0.72	3.81
22	18	7392	4435	0.60	3.37	7161	4297	0.60	3.63	6699	4019	0.60	3.90
22	20	8008	3844	0.48	3.45	7700	3696	0.48	3.69	7238	3474	0.48	3.97
24	16	6853	5482	0.80	3.28	6545	5236	0.80	3.52	6237	4990	0.80	3.81
24	18	7392	5027	0.68	3.37	7161	4869	0.68	3.63	6699	4555	0.68	3.90
24	20	8008	4484	0.56	3.45	7700	4312	0.56	3.69	7238	4053	0.56	3.97
24	22	8624	3795	0.44	3.52	8316	3659	0.44	3.80	7854	3456	0.44	4.04
26	16	6853	6031	0.88	3.28	6545	5760	0.88	3.52	6237	5489	0.88	3.81
26	18	7392	5618	0.76	3.37	7161	5442	0.76	3.63	6699	5091	0.76	3.90
26	20	8008	5125	0.64	3.45	7700	4928	0.64	3.69	7238	4632	0.64	3.97
26	22	8624	4484	0.52	3.52	8316	4324	0.52	3.80	7854	4084	0.52	4.04
27	16	6853	6305	0.92	3.28	6545	6021	0.92	3.52	6237	5738	0.92	3.81
27	18	7392	5914	0.80	3.37	7161	5729	0.80	3.63	6699	5359	0.80	3.90
27	20	8008	5445	0.68	3.45	7700	5236	0.68	3.69	7238	4922	0.68	3.97
27	22	8624	4829	0.56	3.52	8316	4657	0.56	3.80	7854	4398	0.56	4.04
28	16	6853	6579	0.96	3.28	6545	6283	0.96	3.52	6237	5988	0.96	3.81
28	18	7392	6209	0.84	3.37	7161	6015	0.84	3.63	6699	5627	0.84	3.90
28	20	8008	5766	0.72	3.45	7700	5544	0.72	3.69	7238	5211	0.72	3.97
28	22	8624	5174	0.60	3.52	8316	4990	0.60	3.80	7854	4712	0.60	4.04
30	16	6853	6853	1.00	3.28	6545	6545	1.00	3.52	6237	6237	1.00	3.81
30	18	7392	6801	0.92	3.37	7161	6588	0.92	3.63	6699	6163	0.92	3.90
30	20	8008	6406	0.80	3.45	7700	6160	0.80	3.69	7238	5790	0.80	3.97
30	22	8624	5864	0.68	3.52	8316	5655	0.68	3.80	7854	5341	0.68	4.04
32	16	6853	6853	1.00	3.28	6545	6545	1.00	3.52	6237	6237	1.00	3.81
32	18	7392	7392	1.00	3.37	7161	7161	1.00	3.63	6699	6699	1.00	3.90
32	20	8008	7047	0.88	3.45	7700	6776	0.88	3.69	7238	6369	0.88	3.97
32	22	8624	6554	0.76	3.52	8316	6320	0.76	3.80	7854	5969	0.76	4.04
34	16	6853	6853	1.00	3.28	6545	6545	1.00	3.52	6237	6237	1.00	3.81
34	18	7392	7392	1.00	3.37	7161	7161	1.00	3.63	6699	6699	1.00	3.90
34	20	8008	7688	0.96	3.45	7700	7392	0.96	3.69	7238	6948	0.96	3.97
34	22	8624	7244	0.84	3.52	8316	6985	0.84	3.80	7854	6597	0.84	4.04

NOTE: CA : Capacity (W) SHC: Sensible heat capacity (W)
P.C.: Power consumption (kW) SHF: Sensible heat factor

COOLING CAPACITY (23)

PLA-RP4AA.UK PLA-RP4AA₁.UK / PUH-P4VGAA.UK PUH-P4YGAA.UK
PUH-P4VGAA₁.UK PUH-P4YGAA₁.UK
PU-P4VGAA.UK PU-P4YGAA.UK
PU-P4VGAA₁.UK PU-P4YGAA₁.UK

(230V)

Indoor intake air D.B.(°C)	Indoor intake air W.B.(°C)	Outdoor intake air D.B.(°C)											
		20				25				30			
		CA	SHC	SHF	P.C.	CA	SHC	SHF	P.C.	CA	SHC	SHF	P.C.
20	16	9504	6463	0.68	2.94	9216	6267	0.68	3.11	8928	6071	0.68	3.29
20	18	10176	5699	0.56	3.00	9888	5537	0.56	3.16	9552	5349	0.56	3.39
20	20	10944	4815	0.44	3.09	10704	4710	0.44	3.24	10416	4583	0.44	3.46
22	16	9504	7223	0.76	2.94	9216	7004	0.76	3.11	8928	6785	0.76	3.29
22	18	10176	6513	0.64	3.00	9888	6328	0.64	3.16	9552	6113	0.64	3.39
22	20	10944	5691	0.52	3.09	10704	5566	0.52	3.24	10416	5416	0.52	3.46
24	16	9504	7983	0.84	2.94	9216	7741	0.84	3.11	8928	7500	0.84	3.29
24	18	10176	7327	0.72	3.00	9888	7119	0.72	3.16	9552	6877	0.72	3.39
24	20	10944	6566	0.60	3.09	10704	6422	0.60	3.24	10416	6250	0.60	3.46
24	22	11664	5599	0.48	3.16	11424	5484	0.48	3.35	11136	5345	0.48	3.57
26	16	9504	8744	0.92	2.94	9216	8479	0.92	3.11	8928	8214	0.92	3.29
26	18	10176	8141	0.80	3.00	9888	7910	0.80	3.16	9552	7642	0.80	3.39
26	20	10944	7442	0.68	3.09	10704	7279	0.68	3.24	10416	7083	0.68	3.46
26	22	11664	6532	0.56	3.16	11424	6397	0.56	3.35	11136	6236	0.56	3.57
27	16	9504	9124	0.96	2.94	9216	8847	0.96	3.11	8928	8571	0.96	3.29
27	18	10176	8548	0.84	3.00	9888	8306	0.84	3.16	9552	8024	0.84	3.39
27	20	10944	7880	0.72	3.09	10704	7707	0.72	3.24	10416	7500	0.72	3.46
27	22	11664	6998	0.60	3.16	11424	6854	0.60	3.35	11136	6682	0.60	3.57
28	16	9504	9504	1.00	2.94	9216	9216	1.00	3.11	8928	8928	1.00	3.29
28	18	10176	8955	0.88	3.00	9888	8701	0.88	3.16	9552	8406	0.88	3.39
28	20	10944	8317	0.76	3.09	10704	8135	0.76	3.24	10416	7916	0.76	3.46
28	22	11664	7465	0.64	3.16	11424	7311	0.64	3.35	11136	7127	0.64	3.57
30	16	9504	9504	1.00	2.94	9216	9216	1.00	3.11	8928	8928	1.00	3.29
30	18	10176	9769	0.96	3.00	9888	9492	0.96	3.16	9552	9170	0.96	3.39
30	20	10944	9193	0.84	3.09	10704	8991	0.84	3.24	10416	8749	0.84	3.46
30	22	11664	8398	0.72	3.16	11424	8225	0.72	3.35	11136	8018	0.72	3.57
32	16	9504	9504	1.00	2.94	9216	9216	1.00	3.11	8928	8928	1.00	3.29
32	18	10176	10176	1.00	3.00	9888	9888	1.00	3.16	9552	9552	1.00	3.39
32	20	10944	10068	0.92	3.09	10704	9848	0.92	3.24	10416	9583	0.92	3.46
32	22	11664	9331	0.80	3.16	11424	9139	0.80	3.35	11136	8909	0.80	3.57
34	16	9504	9504	1.00	2.94	9216	9216	1.00	3.11	8928	8928	1.00	3.29
34	18	10176	10176	1.00	3.00	9888	9888	1.00	3.16	9552	9552	1.00	3.39
34	20	10944	10944	1.00	3.09	10704	10704	1.00	3.24	10416	10416	1.00	3.46
34	22	11664	10264	0.88	3.16	11424	10053	0.88	3.35	11136	9800	0.88	3.57

NOTE: CA : Capacity (W) SHC: Sensible heat capacity (W)
P.C.: Power consumption (kW) SHF: Sensible heat factor

COOLING CAPACITY (24)

PLA-RP4AA.UK PLA-RP4AA₁.UK / PUH-P4VGAA.UK PUH-P4YGAA.UK
PUH-P4VGAA₁.UK PUH-P4YGAA₁.UK
PU-P4VGAA.UK PU-P4YGAA.UK
PU-P4VGAA₁.UK PU-P4YGAA₁.UK

(230V)

Indoor intake air D.B.(°C)	Indoor intake air W.B.(°C)	Outdoor intake air D.B.(°C)											
		35				40				45			
		CA	SHC	SHF	P.C.	CA	SHC	SHF	P.C.	CA	SHC	SHF	P.C.
20	16	8544	5810	0.68	3.53	8160	5549	0.68	3.79	7776	5288	0.68	4.10
20	18	9216	5161	0.56	3.62	8928	5000	0.56	3.90	8352	4677	0.56	4.20
20	20	9984	4393	0.44	3.72	9600	4224	0.44	3.97	9024	3971	0.44	4.27
22	16	8544	6493	0.76	3.53	8160	6202	0.76	3.79	7776	5910	0.76	4.10
22	18	9216	5898	0.64	3.62	8928	5714	0.64	3.90	8352	5345	0.64	4.20
22	20	9984	5192	0.52	3.72	9600	4992	0.52	3.97	9024	4692	0.52	4.27
24	16	8544	7177	0.84	3.53	8160	6854	0.84	3.79	7776	6532	0.84	4.10
24	18	9216	6636	0.72	3.62	8928	6428	0.72	3.90	8352	6013	0.72	4.20
24	20	9984	5990	0.60	3.72	9600	5760	0.60	3.97	9024	5414	0.60	4.27
24	22	10752	5161	0.48	3.79	10368	4977	0.48	4.08	9792	4700	0.48	4.34
26	16	8544	7860	0.92	3.53	8160	7507	0.92	3.79	7776	7154	0.92	4.10
26	18	9216	7373	0.80	3.62	8928	7142	0.80	3.90	8352	6682	0.80	4.20
26	20	9984	6789	0.68	3.72	9600	6528	0.68	3.97	9024	6136	0.68	4.27
26	22	10752	6021	0.56	3.79	10368	5806	0.56	4.08	9792	5484	0.56	4.34
27	16	8544	8202	0.96	3.53	8160	7834	0.96	3.79	7776	7465	0.96	4.10
27	18	9216	7741	0.84	3.62	8928	7500	0.84	3.90	8352	7016	0.84	4.20
27	20	9984	7188	0.72	3.72	9600	6912	0.72	3.97	9024	6497	0.72	4.27
27	22	10752	6451	0.60	3.79	10368	6221	0.60	4.08	9792	5875	0.60	4.34
28	16	8544	8544	1.00	3.53	8160	8160	1.00	3.79	7776	7776	1.00	4.10
28	18	9216	8110	0.88	3.62	8928	7857	0.88	3.90	8352	7350	0.88	4.20
28	20	9984	7588	0.76	3.72	9600	7296	0.76	3.97	9024	6858	0.76	4.27
28	22	10752	6881	0.64	3.79	10368	6636	0.64	4.08	9792	6267	0.64	4.34
30	16	8544	8544	1.00	3.53	8160	8160	1.00	3.79	7776	7776	1.00	4.10
30	18	9216	8847	0.96	3.62	8928	8571	0.96	3.90	8352	8018	0.96	4.20
30	20	9984	8387	0.84	3.72	9600	8064	0.84	3.97	9024	7580	0.84	4.27
30	22	10752	7741	0.72	3.79	10368	7465	0.72	4.08	9792	7050	0.72	4.34
32	16	8544	8544	1.00	3.53	8160	8160	1.00	3.79	7776	7776	1.00	4.10
32	18	9216	9216	1.00	3.62	8928	8928	1.00	3.90	8352	8352	1.00	4.20
32	20	9984	9185	0.92	3.72	9600	8832	0.92	3.97	9024	8302	0.92	4.27
32	22	10752	8602	0.80	3.79	10368	8294	0.80	4.08	9792	7834	0.80	4.34
34	16	8544	8544	1.00	3.53	8160	8160	1.00	3.79	7776	7776	1.00	4.10
34	18	9216	9216	1.00	3.62	8928	8928	1.00	3.90	8352	8352	1.00	4.20
34	20	9984	9984	1.00	3.72	9600	9600	1.00	3.97	9024	9024	1.00	4.27
34	22	10752	9462	0.88	3.79	10368	9124	0.88	4.08	9792	8617	0.88	4.34

NOTE: CA : Capacity (W) SHC: Sensible heat capacity (W)
P.C.: Power consumption (kW) SHF: Sensible heat factor

COOLING CAPACITY (25)
PLA-RP5AA₁.UK / PUH-P5YGAA.UK
PUH-P5YGAA₁.UK
PU-P5YGAA.UK
PU-P5YGAA₁.UK

(230V)

Indoor intake air D.B.(°C)	Indoor intake air W.B.(°C)	Outdoor intake air D.B.(°C)											
		20				25				30			
		CA	SHC	SHF	P.C.	CA	SHC	SHF	P.C.	CA	SHC	SHF	P.C.
20	16	13167	8164	0.62	4.07	12768	7916	0.62	4.30	12369	7669	0.62	4.56
20	18	14098	7049	0.50	4.15	13699	6850	0.50	4.38	13234	6617	0.50	4.68
20	20	15162	5762	0.38	4.28	14830	5635	0.38	4.48	14431	5484	0.38	4.78
22	16	13167	9217	0.70	4.07	12768	8938	0.70	4.30	12369	8658	0.70	4.56
22	18	14098	8177	0.58	4.15	13699	7945	0.58	4.38	13234	7675	0.58	4.68
22	20	15162	6975	0.46	4.28	14830	6822	0.46	4.48	14431	6638	0.46	4.78
24	16	13167	10270	0.78	4.07	12768	9959	0.78	4.30	12369	9648	0.78	4.56
24	18	14098	9305	0.66	4.15	13699	9041	0.66	4.38	13234	8734	0.66	4.68
24	20	15162	8187	0.54	4.28	14830	8008	0.54	4.48	14431	7792	0.54	4.78
24	22	16160	6787	0.42	4.38	15827	6647	0.42	4.63	15428	6480	0.42	4.94
26	16	13167	11324	0.86	4.07	12768	10980	0.86	4.30	12369	10637	0.86	4.56
26	18	14098	10433	0.74	4.15	13699	10137	0.74	4.38	13234	9793	0.74	4.68
26	20	15162	9400	0.62	4.28	14830	9194	0.62	4.48	14431	8947	0.62	4.78
26	22	16160	8080	0.50	4.38	15827	7914	0.50	4.63	15428	7714	0.50	4.94
27	16	13167	11850	0.90	4.07	12768	11491	0.90	4.30	12369	11132	0.90	4.56
27	18	14098	10996	0.78	4.15	13699	10685	0.78	4.38	13234	10322	0.78	4.68
27	20	15162	10007	0.66	4.28	14830	9787	0.66	4.48	14431	9524	0.66	4.78
27	22	16160	8726	0.54	4.38	15827	8547	0.54	4.63	15428	8331	0.54	4.94
28	16	13167	12377	0.94	4.07	12768	12002	0.94	4.30	12369	11627	0.94	4.56
28	18	14098	11560	0.82	4.15	13699	11233	0.82	4.38	13234	10851	0.82	4.68
28	20	15162	10613	0.70	4.28	14830	10381	0.70	4.48	14431	10101	0.70	4.78
28	22	16160	9373	0.58	4.38	15827	9180	0.58	4.63	15428	8948	0.58	4.94
30	16	13167	13167	1.00	4.07	12768	12768	1.00	4.30	12369	12369	1.00	4.56
30	18	14098	12688	0.90	4.15	13699	12329	0.90	4.38	13234	11910	0.90	4.68
30	20	15162	11826	0.78	4.28	14830	11567	0.78	4.48	14431	11256	0.78	4.78
30	22	16160	10665	0.66	4.38	15827	10446	0.66	4.63	15428	10182	0.66	4.94
32	16	13167	13167	1.00	4.07	12768	12768	1.00	4.30	12369	12369	1.00	4.56
32	18	14098	13816	0.98	4.15	13699	13425	0.98	4.38	13234	12969	0.98	4.68
32	20	15162	13039	0.86	4.28	14830	12753	0.86	4.48	14431	12410	0.86	4.78
32	22	16160	11958	0.74	4.38	15827	11712	0.74	4.63	15428	11417	0.74	4.94
34	16	13167	13167	1.00	4.07	12768	12768	1.00	4.30	12369	12369	1.00	4.56
34	18	14098	14098	1.00	4.15	13699	13699	1.00	4.38	13234	13234	1.00	4.68
34	20	15162	14252	0.94	4.28	14830	13940	0.94	4.48	14431	13565	0.94	4.78
34	22	16160	13251	0.82	4.38	15827	12978	0.82	4.63	15428	12651	0.82	4.94

NOTE: CA : Capacity (W) SHC: Sensible heat capacity (W)
P.C.: Power consumption (kW) SHF: Sensible heat factor

COOLING CAPACITY (26)

PLA-RP5AA₁.UK / PUH-P5YGAA.UK
PUH-P5YGAA₁.UK
PU-P5YGAA.UK
PU-P5YGAA₁.UK

(230V)

Indoor intake air D.B.(°C)	Indoor intake air W.B.(°C)	Outdoor intake air D.B.(°C)											
		35				40				45			
		CA	SHC	SHF	P.C.	CA	SHC	SHF	P.C.	CA	SHC	SHF	P.C.
20	16	11837	7339	0.62	4.89	11305	7009	0.62	5.24	10773	6679	0.62	5.68
20	18	12768	6384	0.50	5.01	12369	6185	0.50	5.40	11571	5786	0.50	5.80
20	20	13832	5256	0.38	5.14	13300	5054	0.38	5.50	12502	4751	0.38	5.90
22	16	11837	8286	0.70	4.89	11305	7914	0.70	5.24	10773	7541	0.70	5.68
22	18	12768	7405	0.58	5.01	12369	7174	0.58	5.40	11571	6711	0.58	5.80
22	20	13832	6363	0.46	5.14	13300	6118	0.46	5.50	12502	5751	0.46	5.90
24	16	11837	9233	0.78	4.89	11305	8818	0.78	5.24	10773	8403	0.78	5.68
24	18	12768	8427	0.66	5.01	12369	8164	0.66	5.40	11571	7637	0.66	5.80
24	20	13832	7469	0.54	5.14	13300	7182	0.54	5.50	12502	6751	0.54	5.90
24	22	14896	6256	0.42	5.24	14364	6033	0.42	5.65	13566	5698	0.42	6.01
26	16	11837	10180	0.86	4.89	11305	9722	0.86	5.24	10773	9265	0.86	5.68
26	18	12768	9448	0.74	5.01	12369	9153	0.74	5.40	11571	8563	0.74	5.80
26	20	13832	8576	0.62	5.14	13300	8246	0.62	5.50	12502	7751	0.62	5.90
26	22	14896	7448	0.50	5.24	14364	7182	0.50	5.65	13566	6783	0.50	6.01
27	16	11837	10653	0.90	4.89	11305	10175	0.90	5.24	10773	9696	0.90	5.68
27	18	12768	9959	0.78	5.01	12369	9648	0.78	5.40	11571	9025	0.78	5.80
27	20	13832	9129	0.66	5.14	13300	8778	0.66	5.50	12502	8251	0.66	5.90
27	22	14896	8044	0.54	5.24	14364	7757	0.54	5.65	13566	7326	0.54	6.01
28	16	11837	11127	0.94	4.89	11305	10627	0.94	5.24	10773	10127	0.94	5.68
28	18	12768	10470	0.82	5.01	12369	10143	0.82	5.40	11571	9488	0.82	5.80
28	20	13832	9682	0.70	5.14	13300	9310	0.70	5.50	12502	8751	0.70	5.90
28	22	14896	8640	0.58	5.24	14364	8331	0.58	5.65	13566	7868	0.58	6.01
30	16	11837	11837	1.00	4.89	11305	11305	1.00	5.24	10773	10773	1.00	5.68
30	18	12768	11491	0.90	5.01	12369	11132	0.90	5.40	11571	10414	0.90	5.80
30	20	13832	10789	0.78	5.14	13300	10374	0.78	5.50	12502	9752	0.78	5.90
30	22	14896	9831	0.66	5.24	14364	9480	0.66	5.65	13566	8954	0.66	6.01
32	16	11837	11837	1.00	4.89	11305	11305	1.00	5.24	10773	10773	1.00	5.68
32	18	12768	12513	0.98	5.01	12369	12122	0.98	5.40	11571	11340	0.98	5.80
32	20	13832	11896	0.86	5.14	13300	11438	0.86	5.50	12502	10752	0.86	5.90
32	22	14896	11023	0.74	5.24	14364	10629	0.74	5.65	13566	10039	0.74	6.01
34	16	11837	11837	1.00	4.89	11305	11305	1.00	5.24	10773	10773	1.00	5.68
34	18	12768	12768	1.00	5.01	12369	12369	1.00	5.40	11571	11571	1.00	5.80
34	20	13832	13002	0.94	5.14	13300	12502	0.94	5.50	12502	11752	0.94	5.90
34	22	14896	12215	0.82	5.24	14364	11778	0.82	5.65	13566	11124	0.82	6.01

NOTE: CA : Capacity (W) SHC: Sensible heat capacity (W)
P.C.: Power consumption (kW) SHF: Sensible heat factor

COOLING CAPACITY (27)

**PLA-RP6AA.UK PLA-RP6AA₁.UK / PUH-P6YGAA.UK
 PUH-P6YGAA₁.UK
 PU-P6YGAA.UK
 PU-P6YGAA₁.UK**

(230V)

Indoor intake air D.B.(°C)	Indoor intake air W.B.(°C)	Outdoor intake air D.B.(°C)											
		20				25				30			
		CA	SHC	SHF	P.C.	CA	SHC	SHF	P.C.	CA	SHC	SHF	P.C.
20	16	14058	8294	0.59	4.72	13632	8043	0.59	4.99	13206	7792	0.59	5.28
20	18	15052	7074	0.47	4.81	14626	6874	0.47	5.07	14129	6641	0.47	5.43
20	20	16188	5666	0.35	4.96	15833	5542	0.35	5.19	15407	5392	0.35	5.55
22	16	14058	9419	0.67	4.72	13632	9133	0.67	4.99	13206	8848	0.67	5.28
22	18	15052	8279	0.55	4.81	14626	8044	0.55	5.07	14129	7771	0.55	5.43
22	20	16188	6961	0.43	4.96	15833	6808	0.43	5.19	15407	6625	0.43	5.55
24	16	14058	10544	0.75	4.72	13632	10224	0.75	4.99	13206	9905	0.75	5.28
24	18	15052	9483	0.63	4.81	14626	9214	0.63	5.07	14129	8901	0.63	5.43
24	20	16188	8256	0.51	4.96	15833	8075	0.51	5.19	15407	7858	0.51	5.55
24	22	17253	6729	0.39	5.07	16898	6590	0.39	5.37	16472	6424	0.39	5.72
26	16	14058	11668	0.83	4.72	13632	11315	0.83	4.99	13206	10961	0.83	5.28
26	18	15052	10687	0.71	4.81	14626	10384	0.71	5.07	14129	10032	0.71	5.43
26	20	16188	9551	0.59	4.96	15833	9341	0.59	5.19	15407	9090	0.59	5.55
26	22	17253	8109	0.47	5.07	16898	7942	0.47	5.37	16472	7742	0.47	5.72
27	16	14058	12230	0.87	4.72	13632	11860	0.87	4.99	13206	11489	0.87	5.28
27	18	15052	11289	0.75	4.81	14626	10970	0.75	5.07	14129	10597	0.75	5.43
27	20	16188	10198	0.63	4.96	15833	9975	0.63	5.19	15407	9706	0.63	5.55
27	22	17253	8799	0.51	5.07	16898	8618	0.51	5.37	16472	8401	0.51	5.72
28	16	14058	12793	0.91	4.72	13632	12405	0.91	4.99	13206	12017	0.91	5.28
28	18	15052	11891	0.79	4.81	14626	11555	0.79	5.07	14129	11162	0.79	5.43
28	20	16188	10846	0.67	4.96	15833	10608	0.67	5.19	15407	10323	0.67	5.55
28	22	17253	9489	0.55	5.07	16898	9294	0.55	5.37	16472	9060	0.55	5.72
30	16	14058	13917	0.99	4.72	13632	13496	0.99	4.99	13206	13074	0.99	5.28
30	18	15052	13095	0.87	4.81	14626	12725	0.87	5.07	14129	12292	0.87	5.43
30	20	16188	12141	0.75	4.96	15833	11875	0.75	5.19	15407	11555	0.75	5.55
30	22	17253	10869	0.63	5.07	16898	10646	0.63	5.37	16472	10377	0.63	5.72
32	16	14058	14058	1.00	4.72	13632	13632	1.00	4.99	13206	13206	1.00	5.28
32	18	15052	14299	0.95	4.81	14626	13895	0.95	5.07	14129	13423	0.95	5.43
32	20	16188	13436	0.83	4.96	15833	13141	0.83	5.19	15407	12788	0.83	5.55
32	22	17253	12250	0.71	5.07	16898	11998	0.71	5.37	16472	11695	0.71	5.72
34	16	14058	14058	1.00	4.72	13632	13632	1.00	4.99	13206	13206	1.00	5.28
34	18	15052	15052	1.00	4.81	14626	14626	1.00	5.07	14129	14129	1.00	5.43
34	20	16188	14731	0.91	4.96	15833	14408	0.91	5.19	15407	14020	0.91	5.55
34	22	17253	13630	0.79	5.07	16898	13349	0.79	5.37	16472	13013	0.79	5.72

NOTE: CA : Capacity (W) SHC: Sensible heat capacity (W)
 P.C.: Power consumption (kW) SHF: Sensible heat factor

COOLING CAPACITY (28)

**PLA-RP6AA.UK PLA-RP6AA₁.UK / PUH-P6YGAA.UK
 PUH-P6YGAA₁.UK
 PU-P6YGAA.UK
 PU-P6YGAA₁.UK**

(230V)

Indoor intake air D.B.(°C)	Indoor intake air W.B.(°C)	Outdoor intake air D.B.(°C)											
		35				40				45			
		CA	SHC	SHF	P.C.	CA	SHC	SHF	P.C.	CA	SHC	SHF	P.C.
20	16	12638	7456	0.59	5.66	12070	7121	0.59	6.08	11502	6786	0.59	6.58
20	18	13632	6407	0.47	5.81	13206	6207	0.47	6.25	12354	5806	0.47	6.73
20	20	14768	5169	0.35	5.96	14200	4970	0.35	6.37	13348	4672	0.35	6.84
22	16	12638	8467	0.67	5.66	12070	8087	0.67	6.08	11502	7706	0.67	6.58
22	18	13632	7498	0.55	5.81	13206	7263	0.55	6.25	12354	6795	0.55	6.73
22	20	14768	6350	0.43	5.96	14200	6106	0.43	6.37	13348	5740	0.43	6.84
24	16	12638	9479	0.75	5.66	12070	9053	0.75	6.08	11502	8627	0.75	6.58
24	18	13632	8588	0.63	5.81	13206	8320	0.63	6.25	12354	7783	0.63	6.73
24	20	14768	7532	0.51	5.96	14200	7242	0.51	6.37	13348	6807	0.51	6.84
24	22	15904	6203	0.39	6.08	15336	5981	0.39	6.55	14484	5649	0.39	6.96
26	16	12638	10490	0.83	5.66	12070	10018	0.83	6.08	11502	9547	0.83	6.58
26	18	13632	9679	0.71	5.81	13206	9376	0.71	6.25	12354	8771	0.71	6.73
26	20	14768	8713	0.59	5.96	14200	8378	0.59	6.37	13348	7875	0.59	6.84
26	22	15904	7475	0.47	6.08	15336	7208	0.47	6.55	14484	6807	0.47	6.96
27	16	12638	10995	0.87	5.66	12070	10501	0.87	6.08	11502	10007	0.87	6.58
27	18	13632	10224	0.75	5.81	13206	9905	0.75	6.25	12354	9266	0.75	6.73
27	20	14768	9304	0.63	5.96	14200	8946	0.63	6.37	13348	8409	0.63	6.84
27	22	15904	8111	0.51	6.08	15336	7821	0.51	6.55	14484	7387	0.51	6.96
28	16	12638	11501	0.91	5.66	12070	10984	0.91	6.08	11502	10467	0.91	6.58
28	18	13632	10769	0.79	5.81	13206	10433	0.79	6.25	12354	9760	0.79	6.73
28	20	14768	9895	0.67	5.96	14200	9514	0.67	6.37	13348	8943	0.67	6.84
28	22	15904	8747	0.55	6.08	15336	8435	0.55	6.55	14484	7966	0.55	6.96
30	16	12638	12512	0.99	5.66	12070	11949	0.99	6.08	11502	11387	0.99	6.58
30	18	13632	11860	0.87	5.81	13206	11489	0.87	6.25	12354	10748	0.87	6.73
30	20	14768	11076	0.75	5.96	14200	10650	0.75	6.37	13348	10011	0.75	6.84
30	22	15904	10020	0.63	6.08	15336	9662	0.63	6.55	14484	9125	0.63	6.96
32	16	12638	12638	1.00	5.66	12070	12070	1.00	6.08	11502	11502	1.00	6.58
32	18	13632	12950	0.95	5.81	13206	12546	0.95	6.25	12354	11736	0.95	6.73
32	20	14768	12257	0.83	5.96	14200	11786	0.83	6.37	13348	11079	0.83	6.84
32	22	15904	11292	0.71	6.08	15336	10889	0.71	6.55	14484	10284	0.71	6.96
34	16	12638	12638	1.00	5.66	12070	12070	1.00	6.08	11502	11502	1.00	6.58
34	18	13632	13632	1.00	5.81	13206	13206	1.00	6.25	12354	12354	1.00	6.73
34	20	14768	13439	0.91	5.96	14200	12922	0.91	6.37	13348	12147	0.91	6.84
34	22	15904	12564	0.79	6.08	15336	12115	0.79	6.55	14484	11442	0.79	6.96

NOTE: CA : Capacity (W) SHC: Sensible heat capacity (W)
 P.C.: Power consumption (kW) SHF: Sensible heat factor

6-1-2. HEATING CAPACITY

PLA-RP•AA.UK PLA-RP•AA₁.UK / PUHZ-RP•VHA PUHZ-RP•VHA₁

(230V)

Service Ref.	Indoor intake are D.B. (°C)	Outdoor intake air W.B. (°C)											
		-10		-5		0		5		10		15	
		CA	P.C.	CA	P.C.	CA	P.C.	CA	P.C.	CA	P.C.	CA	P.C.
PLA-RP1.6AA.UK	15	2,604	0.66	2,829	0.73	3,157	0.84	4,141	1.01	4,674	1.12	5,207	1.21
	20	2,501	0.72	2,706	0.78	2,993	0.91	3,998	1.09	4,510	1.21	5,023	1.30
	25	2,419	0.76	2,624	0.85	2,870	0.99	3,772	1.15	4,346	1.29	4,838	1.39
PLA-RP2AA.UK	15	3,810	0.96	4,140	1.05	4,620	1.22	6,060	1.46	6,840	1.62	7,620	1.75
	20	3,660	1.04	3,960	1.13	4,380	1.31	5,850	1.57	6,600	1.75	7,350	1.88
	25	3,540	1.10	3,840	1.23	4,200	1.43	5,520	1.67	6,360	1.87	7,080	2.02
PLA-RP2.5AA.UK	15	4,445	1.09	4,830	1.20	5,390	1.39	7,070	1.67	7,980	1.85	8,890	2.00
	20	4,270	1.18	4,620	1.30	5,110	1.50	6,825	1.79	7,700	2.00	8,575	2.15
	25	4,130	1.26	4,480	1.23	4,900	1.63	6,440	1.91	7,420	2.14	8,260	2.30
PLA-RP3AA.UK PLA-RP3AA ₁ .UK	15	5,080	1.38	5,520	1.52	6,160	1.76	8,080	2.11	9,120	2.34	10,160	2.53
	20	4,880	1.50	5,280	1.64	5,840	1.90	7,800	2.27	8,800	2.53	9,800	2.71
	25	4,720	1.59	5,120	1.78	5,600	2.06	7,360	2.41	8,480	2.70	9,440	2.91
PLA-RP4AA.UK PLA-RP4AA ₁ .UK	15	7,112	2.00	7,728	2.20	8,624	2.54	11,312	3.05	12,768	3.39	14,224	3.66
	20	6,832	2.17	7,392	2.37	8,176	2.75	10,920	3.29	12,320	3.66	13,720	3.93
	25	6,608	2.31	7,168	2.58	7,840	2.98	10,304	3.49	11,872	3.92	13,216	4.22
PLA-RP5AA.UK PLA-RP5AA ₁ .UK	15	8,890	2.52	9,660	2.78	10,780	3.20	14,140	3.84	15,960	4.27	17,780	4.61
	20	8,540	2.73	9,240	2.99	10,220	3.46	13,650	4.14	15,400	4.61	17,150	4.95
	25	8,260	2.90	8,960	3.25	9,800	3.76	12,880	4.40	14,840	4.93	16,520	5.32
PLA-RP6AA.UK PLA-RP6AA ₁ .UK	15	10,160	2.90	11,040	3.19	12,320	3.68	16,160	4.42	18,240	4.91	20,320	5.30
	20	9,760	3.14	10,560	3.44	11,680	3.98	15,600	4.76	17,600	5.30	19,600	5.70
	25	9,440	3.34	10,240	3.73	11,200	4.32	14,720	5.06	16,960	5.67	18,880	6.11

NOTE: CA: Capacity (W) P.C.: Power consumption (kW)

PLA-RP•AA.UK PLA-RP•AA₁.UK / PUH-P•VGAA.UK PUH-P•YGAA.UK
PUH-P•VGAA₁.UK PUH-P•YGAA₁.UK

(230V)

Service Ref.	Indoor intake are D.B. (°C)	Outdoor intake air W.B. (°C)											
		-10		-5		0		5		10		15	
		CA	P.C.	CA	P.C.	CA	P.C.	CA	P.C.	CA	P.C.	CA	P.C.
PLA-RP1.6AA.UK	15	3,143	1.00	3,416	1.11	3,812	1.28	5,000	1.53	5,643	1.70	6,287	1.84
	20	3,020	1.09	3,267	1.19	3,614	1.38	4,826	1.65	5,445	1.84	6,064	1.97
	25	2,921	1.16	3,168	1.29	3,465	1.50	4,554	1.75	5,247	1.96	5,841	2.12
PLA-RP2AA.UK	15	4,032	1.30	4,382	1.43	4,890	1.65	6,414	1.98	7,239	2.20	8,065	2.38
	20	3,874	1.41	4,191	1.54	4,636	1.78	6,191	2.13	6,985	2.38	7,779	2.55
	25	3,747	1.50	4,064	1.67	4,445	1.94	5,842	2.27	6,731	2.54	7,493	2.74
PLA-RP2.5AA.UK	15	4,636	1.42	5,037	1.56	5,621	1.80	7,373	2.16	8,322	2.40	9,271	2.59
	20	4,453	1.54	4,818	1.68	5,329	1.94	7,118	2.33	8,030	2.59	8,943	2.78
	25	4,307	1.63	4,672	1.82	5,110	2.11	6,716	2.47	7,738	2.77	8,614	2.99
PLA-RP3AA.UK PLA-RP3AA ₁ .UK	15	5,842	2.05	6,348	2.26	7,084	2.61	9,292	3.13	10,488	3.48	11,684	3.76
	20	5,612	2.23	6,072	2.44	6,716	2.82	8,970	3.38	10,120	3.76	11,270	4.04
	25	5,428	2.37	5,888	2.64	6,440	3.06	8,464	3.58	9,752	4.02	10,856	4.33
PLA-RP4AA.UK PLA-RP4AA ₁ .UK	15	6,668	2.31	7,245	2.54	8,085	2.93	10,605	3.52	11,970	3.91	13,335	4.22
	20	6,405	2.50	6,930	2.74	7,665	3.17	10,238	3.79	11,550	4.22	12,863	4.54
	25	6,195	2.66	6,720	2.97	7,350	3.44	9,660	4.03	11,130	4.52	12,390	4.87
PLA-RP5AA ₁ .UK	15	9,906	3.27	10,764	3.60	12,012	4.16	15,756	4.99	17,784	5.54	19,812	5.98
	20	9,516	3.55	10,296	3.88	11,388	4.49	15,210	5.37	17,160	5.98	19,110	6.43
	25	9,204	3.77	9,984	4.21	10,920	4.88	14,352	5.71	16,536	6.40	18,408	6.90
PLA-RP6AA.UK PLA-RP6AA ₁ .UK	15	10,795	3.75	11,730	4.13	13,090	4.76	17,170	5.72	19,380	6.35	21,590	6.86
	20	10,370	4.06	11,220	4.45	12,410	5.14	16,575	6.16	18,700	6.86	20,825	7.37
	25	10,030	4.32	10,880	4.83	11,900	5.59	15,640	6.54	18,020	7.33	20,060	7.91

NOTE: CA: Capacity (W) P.C.: Power consumption (kW)

6-2. PERFORMANCE CURVE

PLA-RP•AA.UK PLA-RP•AA₁.UK / PUHZ-RP•VHA PUHZ-RP•VHA₁

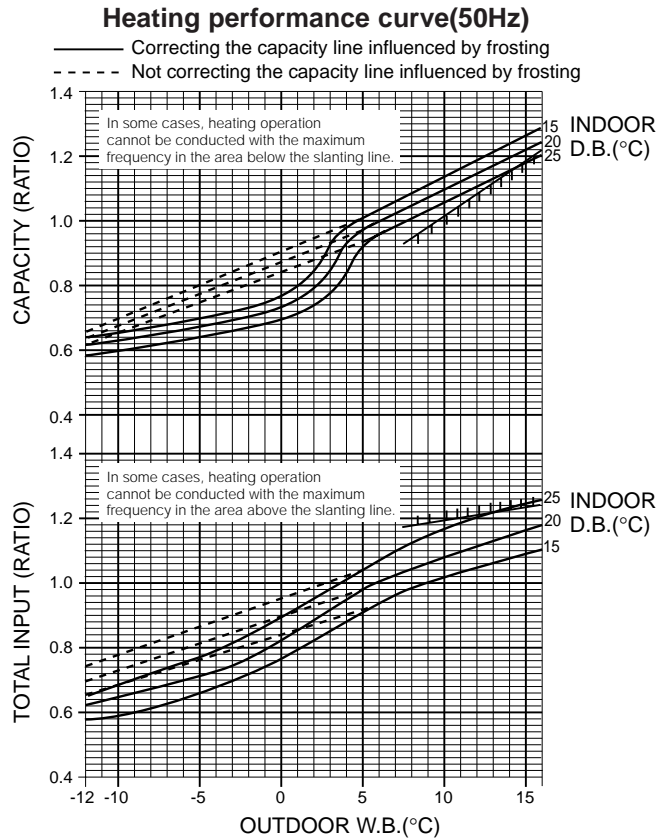
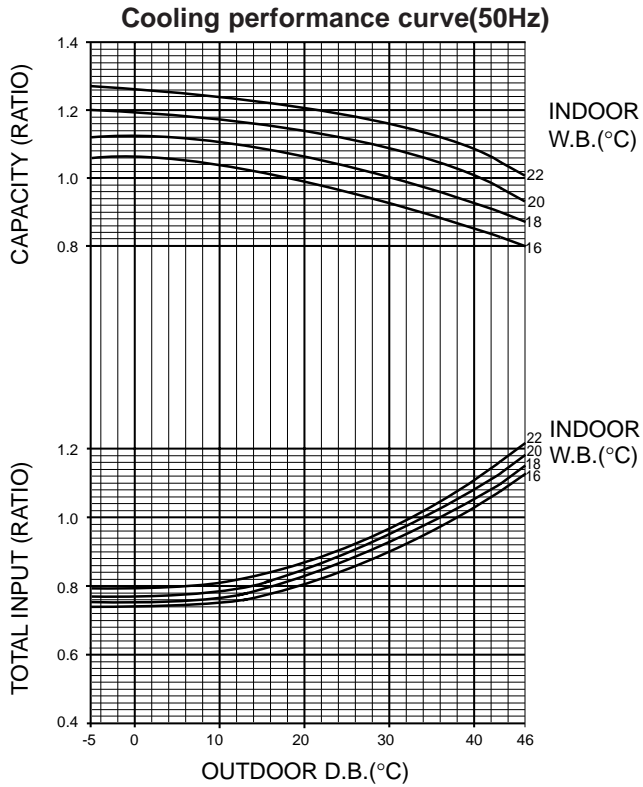

PLA-RP•AA.UK PLA-RP•AA₁.UK / PUH-P•VGAA.UK PUH-P•YGAA.UK
 PUH-P•VGAA₁.UK PUH-P•YGAA₁.UK
 PU-P•VGAA.UK PU-P•YGAA.UK
 PU-P•VGAA₁.UK PU-P•YGAA₁.UK

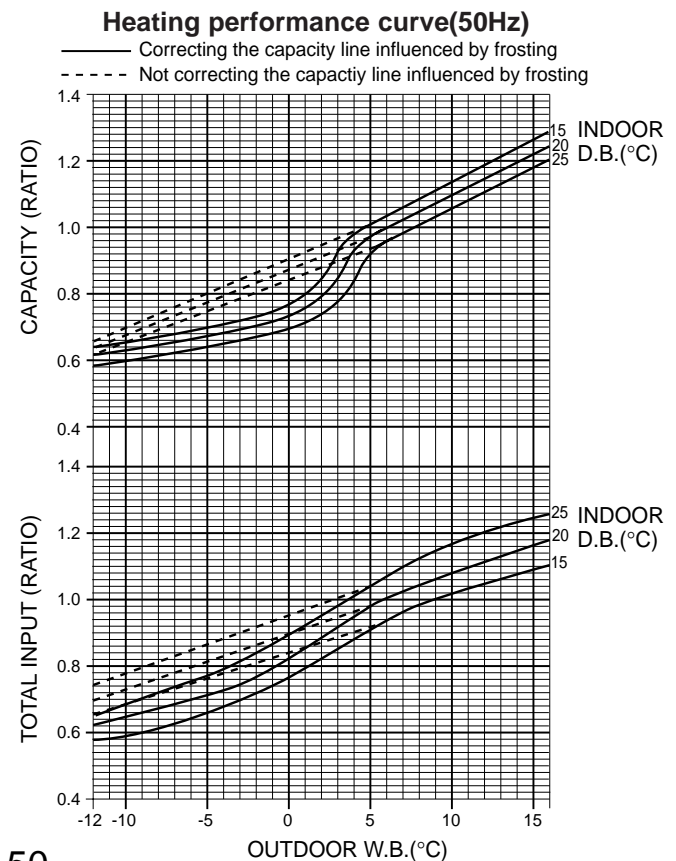
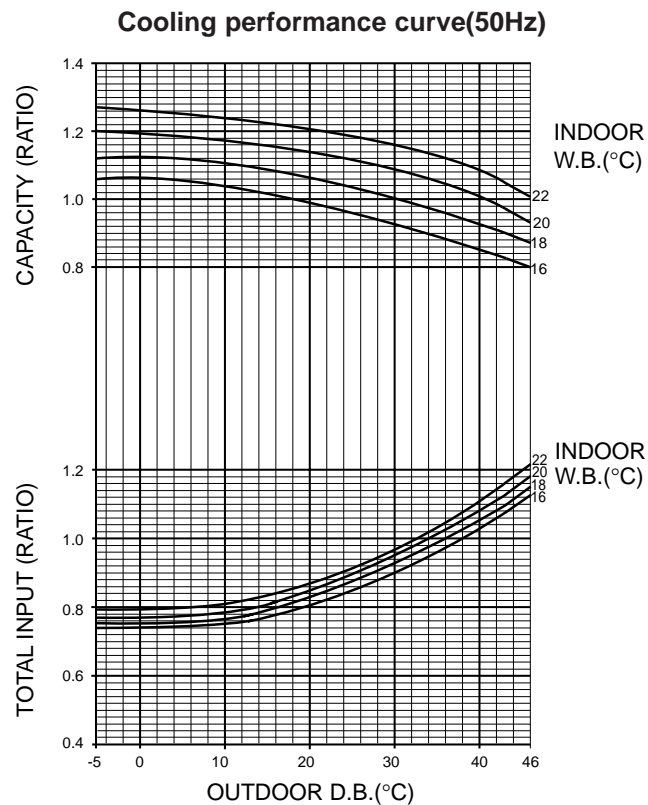

6-3. CORRECTION FACTRS

PLA-RP•AA.UK PLA-RP•AA₁.UK / PUHZ-RP•VHA PUHZ-RP•VHA₁
Cooling capacity correction factors

Service Ref.	Refrigerant piping length (one way)									
	5m	10m	20m	30m	40m	50m	55m	60m	70m	80m
PLA-RP1.6AA.UK	1.00	0.992	0.976	0.962	0.949	0.936	0.930	—	—	—
PLA-RP2AA.UK	1.00	0.985	0.957	0.931	0.908	0.886	0.876	—	—	—
PLA-RP2.5AA.UK	1.00	0.992	0.976	0.962	0.949	0.936	0.930	—	—	—
PLA-RP3AA.UK PLA-RP3AA ₁ .UK	1.00	0.988	0.966	0.946	0.929	0.913	0.905	—	—	—
PLA-RP4AA.UK PLA-RP4AA ₁ .UK	1.00	0.985	0.957	0.931	0.908	0.886	0.876	0.865	0.846	0.829
PLA-RP5AA.UK PLA-RP5AA ₁ .UK	1.00	0.981	0.946	0.914	0.885	0.858	0.845	0.834	0.812	0.792
PLA-RP6AA.UK PLA-RP6AA ₁ .UK	1.00	0.976	0.931	0.893	0.858	0.827	0.813	0.800	0.775	0.753

Heating capacity correction factors

Service Ref.	Refrigerant piping length (one way)									
	5m	10m	20m	30m	40m	50m	55m	60m	70m	80m
PLA-RP1.6AA.UK	1.00	0.997	0.991	0.985	0.979	0.973	0.970	—	—	—
PLA-RP2AA.UK	1.00	0.997	0.991	0.985	0.979	0.973	0.970	—	—	—
PLA-RP2.5AA.UK	1.00	0.997	0.991	0.985	0.979	0.973	0.970	—	—	—
PLA-RP3AA.UK PLA-RP3AA ₁ .UK	1.00	0.997	0.991	0.985	0.979	0.973	0.970	—	—	—
PLA-RP4AA.UK PLA-RP4AA ₁ .UK	1.00	0.997	0.991	0.985	0.979	0.973	0.970	0.967	0.961	0.955
PLA-RP5AA.UK PLA-RP5AA ₁ .UK	1.00	0.997	0.991	0.985	0.979	0.973	0.970	0.967	0.961	0.955
PLA-RP6AA.UK PLA-RP6AA ₁ .UK	1.00	0.997	0.991	0.985	0.979	0.973	0.970	0.967	0.961	0.955

PLA-RP•AA.UK PLA-RP•AA₁.UK / PUH-P•VGAA.UK PUH-P•YGAA.UK
PUH-P•VGAA₁.UK PUH-P•YGAA₁.UK
PU-P•VGAA.UK PU-P•YGAA.UK
PU-P•VGAA₁.UK PU-P•YGAA₁.UK

Cooling capacity correction factors

Service Ref.	Refrigerant piping length(one way)					
	5m	10m	20m	30m	40m	50m
PLA-RP1.6AA.UK	1.00	0.993	0.978	0.961	0.948	—
PLA-RP2AA.UK	1.00	0.993	0.978	0.961	0.948	—
PLA-RP2.5AA.UK	1.00	0.989	0.970	0.950	0.930	0.910
PLA-RP3AA.UK PLA-RP3AA ₁ .UK	1.00	0.981	0.952	0.925	0.900	0.874
PLA-RP4AA.UK PLA-RP4AA ₁ .UK	1.00	0.989	0.970	0.950	0.930	0.910
PLA-RP5AA ₁ .UK	1.00	0.981	0.952	0.925	0.900	0.874
PLA-RP6AA.UK PLA-RP6AA ₁ .UK	1.00	0.975	0.935	0.900	0.869	0.840

Heating capacity correction factors

Service Ref.	Refrigerant piping length(one way)					
	5m	10m	20m	30m	40m	50m
PLA-RP1.6AA.UK	1.00	0.998	0.993	0.988	0.983	—
PLA-RP2AA.UK	1.00	0.998	0.993	0.988	0.983	—
PLA-RP2.5AA.UK	1.00	0.998	0.993	0.988	0.983	0.978
PLA-RP3AA.UK PLA-RP3AA ₁ .UK	1.00	0.998	0.993	0.988	0.983	0.978
PLA-RP4AA.UK PLA-RP4AA ₁ .UK	1.00	0.998	0.993	0.988	0.983	0.978
PLA-RP5AA ₁ .UK	1.00	0.998	0.993	0.988	0.983	0.978
PLA-RP6AA.UK PLA-RP6AA ₁ .UK	1.00	0.998	0.993	0.988	0.983	0.978

6-4. STANDARD OPERATION DATA

Heat pump type(1)

Service Ref.			PLA-RP1.6AA.UK		PLA-RP2AA.UK		PLA-RP2.5AA.UK		
Mode			Cooling	Heating	Cooling	Heating	Cooling	Heating	
Total	Capacity	W	3,600	4,100	5,000	6,000	6,000	7,000	
	Input	kW	1.07	1.12	1.55	1.62	1.65	1.85	
Electrical circuit	Indoor unit Service Ref.		PLA-RP1.6AA.UK		PLA-RP2AA.UK		PLA-RP2.5AA.UK		
	Phase , Hz		1 , 50		1 , 50		1 , 50		
	Volts	V	230		230		230		
	Amperes	A	0.79		0.79		0.79		
	Outdoor unit Service Ref.		PUHZ-RP1.6VHA		PUHZ-RP2VHA		PUHZ-RP2.5VHA PUHZ-RP2.5VHA ₁		
	Phase , Hz		1 , 50		1 , 50		1 , 50		
	Volts	V	230		230		230		
	Current	A	4.01	4.23	6.16	6.47	6.61	7.50	
Refrigerant circuit	Discharge pressure	MPa	2.70	2.69	2.91	2.76	2.60	2.63	
	Suction pressure	MPa	1.01	0.74	0.99	0.67	0.99	0.70	
	Discharge temperature	°C	70	71	73	77	65	81	
	Condensing temperature	°C	46	41	49	44	44	44	
	Suction temperature	°C	15	2	11	-1	12	8	
	Ref. pipe length	m	5	5	5	5	5	5	
Indoor side	Intake air temperature	D.B.	°C	27	20	27	20	27	20
		W.B.	°C	19	15	19	15	19	15
	Discharge air temperature	D.B.	°C	15.6	35.5	15.4	37.8	14.3	40.9
Outdoor side	Intake air temperature	D.B.	°C	35	7	35	7	35	7
		W.B.	°C	24	6	24	6	24	6
SHF			0.89	—	0.86	—	0.78	—	
BF			0.11	—	0.14	—	0.14	—	

The unit of pressure has been changed to MPa based on international SI system.
The conversion factor is : 1(MPa)=10.2(kgf/cm²)



Service Ref.			PLA-RP3AA.UK PLA-RP3AA ₁ .UK	PLA-RP4AA.UK PLA-RP4AA ₁ .UK	PLA-RP5AA.UK PLA-RP5AA ₁ .UK	PLA-RP6AA.UK PLA-RP6AA ₁ .UK					
Mode			Cooling	Heating	Cooling	Heating	Cooling	Heating	Cooling	Heating	
Total	Capacity	W	7,100	8,000	10,000	11,200	12,500	14,000	14,000	16,000	
	Input	kW	1.97	2.34	3.03	3.39	3.89	4.27	4.99	4.91	
Electrical circuit	Indoor unit Service Ref.		PLA-RP3AA.UK PLA-RP3AA ₁ .UK	PLA-RP4AA.UK PLA-RP4AA ₁ .UK	PLA-RP5AA.UK PLA-RP5AA ₁ .UK	PLA-RP6AA.UK PLA-RP6AA ₁ .UK					
	Phase , Hz		1 , 50		1 , 50		1 , 50		1 , 50		
	Volts	V	230		230		230		230		
	Amperes	A	0.79		1.25		1.64		1.64		
	Outdoor unit Service Ref.		PUHZ-RP3VHA PUHZ-RP3VHA ₁	PUHZ-RP4VHA PUHZ-RP4VHA ₁	PUHZ-RP5VHA PUHZ-RP5VHA ₁	PUHZ-RP6VHA PUHZ-RP6VHA ₁					
	Phase , Hz		1 , 50		1 , 50		1 , 50		1 , 50		
	Volts	V	230		230		230		230		
	Current	A	8.04	9.74	12.33	13.94	15.80	17.50	20.73	20.37	
Refrigerant circuit	Discharge pressure	MPa	2.68	2.87	2.63	2.80	2.72	2.77	2.86	3.03	
	Suction pressure	MPa	0.94	0.73	0.92	0.72	0.89	0.71	0.80	0.69	
	Discharge temperature	°C	70	74	70	76	70	77	79	83	
	Condensing temperature	°C	46	48	45	48	46	47	48	51	
	Suction temperature	°C	10	1	11	3	8	1	8	1	
	Ref. pipe length	m	5	5	5	5	5	5	5	5	
Indoor side	Intake air temperature	D.B.	°C	27	20	27	20	27	20	27	20
		W.B.	°C	19	15	19	15	19	15	19	15
	Discharge air temperature	D.B.	°C	14.2	41.6	14.0	41.6	12.2	45.5	11.2	49.5
Outdoor side	Intake air temperature	D.B.	°C	35	7	35	7	35	7	35	7
		W.B.	°C	24	6	24	6	24	6	24	6
SHF			0.74	—	0.75	—	0.74	—	0.71	—	
BF			0.18	—	0.15	—	0.06	—	0.06	—	

The unit of pressure has been changed to MPa based on international SI system.
The conversion factor is : 1(MPa)=10.2(kgf/cm²)

Heat pump type (2)

Service Ref.			PLA-RP1.6AA.UK		PLA-RP2AA.UK		PLA-RP2.5AA.UK		
Mode			Cooling	Heating	Cooling	Heating	Cooling	Heating	
Total	Capacity	W	4,500	4,950	5,600	6,350	6,700	7,300	
	Input	kW	1.72	1.70	2.53	2.20	2.57	2.40	
Electrical circuit	Indoor unit Service Ref.		PLA-RP1.6AA.UK		PLA-RP2AA.UK		PLA-RP2.5AA.UK		
	Phase , Hz		1 , 50		1 , 50		1 , 50		
	Volts	V	230		230		230		
	Amperes	A	0.79		0.79		0.79		
	Outdoor unit Service Ref.		PUH-P1.6VGAA.UK PUH-P1.6VGAA ₁ .UK PUH-P1.6YGAA.UK PUH-P1.6YGAA ₁ .UK		PUH-P2VGAA.UK PUH-P2VGAA ₁ .UK PUH-P2YGAA.UK PUH-P2YGAA ₁ .UK		PUH-P2.5VGAA.UK PUH-P2.5VGAA ₁ .UK PUH-P2.5YGAA.UK PUH-P2.5YGAA ₁ .UK		
	Phase , Hz		1/3 , 50		1/3 , 50		1/3 , 50		
	Volts	V	230/400		230/400		230/400		
	Amperes	A	7.43/1.94	7.33/1.91	11.30/3.23	9.72/2.70	11.49/3.29	10.68/3.02	
Refrigerant circuit	Discharge pressure	MPa	2.01	1.92	2.48	1.96	2.18	1.92	
	Suction pressure	MPa	0.59	0.37	0.59	0.38	0.54	0.38	
	Discharge temperature	°C	78	77	85	76	80	75	
	Condensing temperature	°C	48	48	55	45	51	47	
	Suction temperature	°C	11	1	10	0	9	1	
	Ref. pipe length	m	5	5	5	5	5	5	
Indoor side	Intake air temperature	D.B.	°C	27	20	27	20	27	20
		W.B.	°C	19	15	19	15	19	15
	Discharge air temperature	D.B.	°C	14.1	38.9	14.6	38.9	12.9	41.9
Outdoor side	Intake air temperature	D.B.	°C	35	7	35	7	35	7
		W.B.	°C	24	6	24	6	24	6
SHF			0.75	—	0.82	—	0.72	—	
BF			0.16	—	0.12	—	0.14	—	

The unit of pressure has been changed to MPa based on international SI system.
The conversion factor is : 1(MPa)=10.2(kgf/cm²)



Service Ref.			PLA-RP3AA.UK PLA-RP3AA ₁ .UK	PLA-RP4AA.UK PLA-RP4AA ₁ .UK	PLA-RP5AA ₁ .UK	PLA-RP6AA.UK PLA-RP6AA ₁ .UK					
Mode			Cooling	Heating	Cooling	Heating	Cooling	Heating			
Total	Capacity	W	7,700	9,200	9,600	10,500	13,300	15,600	14,200	17,000	
	Input	kW	3.42	3.48	3.68	3.91	5.09	5.54	5.90	6.35	
Electrical circuit	Indoor unit Service Ref.		PLA-RP3AA.UK PLA-RP3AA ₁ .UK	PLA-RP4AA.UK PLA-RP4AA ₁ .UK	PLA-RP5AA ₁ .UK	PLA-RP6AA.UK PLA-RP6AA ₁ .UK					
	Phase , Hz		1 , 50		1 , 50		1 , 50		1 , 50		
	Volts	V	230		230		230		230		
	Amperes	A	0.79		1.25		1.64		1.64		
	Outdoor unit Service Ref.		PUH-P3VGAA.UK PUH-P3VGAA ₁ .UK PUH-P3YGAA.UK PUH-P3YGAA ₁ .UK	PUH-P4VGAA.UK PUH-P4VGAA ₁ .UK PUH-P4YGAA.UK PUH-P4YGAA ₁ .UK	PUH-P5YGAA.UK PUH-P5YGAA ₁ .UK	PUH-P6YGAA.UK PUH-P6YGAA ₁ .UK					
	Phase , Hz		1/3 , 50		1/3 , 50		3 , 50		3 , 50		
	Volts	V	230/400		230/400		400		400		
	Amperes	A	15.55/4.64	15.84/4.74	16.33/4.59	17.43/4.96	6.44	7.16	7.73	8.44	
Refrigerant circuit	Discharge pressure		MPa	2.30	2.38	1.98	2.12	2.11	2.39	2.27	2.36
	Suction pressure		MPa	0.47	0.39	0.54	0.42	0.48	0.42	0.45	0.41
	Discharge temperature		°C	81	88	71	75	71	79	81	84
	Condensing temperature		°C	44	45	42	47	41	44	45	46
	Suction temperature		°C	5	0	8	1	6	0	2	-1
	Ref. pipe length		m	5	5	5	5	5	5	5	5
Indoor side	Intake air temperature	D.B.	°C	27	20	27	20	27	20	27	20
		W.B.	°C	19	15	19	15	19	15	19	15
	Discharge air temperature	D.B.	°C	13.4	45.1	14.0	40.1	11.7	48.7	11.3	51.2
Outdoor side	Intake air temperature	D.B.	°C	35	7	35	7	35	7	35	7
		W.B.	°C	24	6	24	6	24	6	24	6
SHF			0.74	—	0.78	—	0.72	—	0.69	—	
BF			0.13	—	0.12	—	0.06	—	0.09	—	

The unit of pressure has been changed to MPa based on international SI system.
The conversion factor is : 1(MPa)=10.2(kgf/cm²)

Cooling only type (3)

Service Ref.			PLA-RP1.6AA.UK	PLA-RP2AA.UK	PLA-RP2.5AA.UK
Mode			Cooling	Cooling	Cooling
Total	Capacity	W	4,500	5,600	6,700
	Input	kW	1.72	2.53	2.57
Electrical circuit	Indoor unit Service Ref.		PLA-RP1.6AA.UK	PLA-RP2AA.UK	PLA-RP2.5AA.UK
	Phase , Hz		1 , 50	1 , 50	1 , 50
	Volts	V	230	230	230
	Amperes	A	0.79	0.79	0.79
	Outdoor unit Service Ref.		PU-P1.6VGAA.UK PU-P1.6VGAA;.UK PU-P1.6YGAA.UK PU-P1.6YGAA;.UK	PU-P2VGAA.UK PU-P2VGAA;.UK PU-P2YGAA.UK PU-P2YGAA;.UK	PU-P2.5VGAA.UK PU-P2.5VGAA;.UK PU-P2.5YGAA.UK PU-P2.5YGAA;.UK
	Phase , Hz		1/3 , 50	1/3 , 50	1/3 , 50
	Volts	V	230/400	230/400	230/400
	Amperes	A	7.43/1.94	11.30/3.23	11.49/3.29
Refrigerant circuit	Discharge pressure	MPa	2.01	2.48	2.18
	Suction pressure	MPa	0.59	0.59	0.54
	Discharge temperature	°C	78	85	80
	Condensing temperature	°C	48	55	51
	Suction temperature	°C	11	10	9
	Ref. pipe length	m	5	5	5
Indoor side	Intake air temperature	D.B.	°C	27	27
		W.B.	°C	19	19
	Discharge air temperature	D.B.	°C	14.1	14.6
Outdoor side	Intake air temperature	D.B.	°C	35	35
		W.B.	°C	24	24
SHF			0.75	0.82	0.72
BF			0.16	0.12	0.14

The unit of pressure has been changed to MPa based on international SI system.
The conversion factor is : 1(MPa)=10.2(kgf/cm²)



Service Ref.			PLA-RP3AA.UK PLA-RP3AA ₁ .UK	PLA-RP4AA.UK PLA-RP4AA ₁ .UK	PLA-RP5AA ₁ .UK	PLA-RP6AA.UK PLA-RP6AA ₁ .UK	
Mode			Cooling	Cooling	Cooling	Cooling	
Total	Capacity	W	7,700	9,200	13,300	14,200	
	Input	kW	3.42	3.68	5.09	5.90	
Electrical circuit	Indoor unit Service Ref.		PLA-RP3AA.UK PLA-RP3AA ₁ .UK	PLA-RP4AA.UK PLA-RP4AA ₁ .UK	PLA-RP5AA ₁ .UK	PLA-RP6AA.UK PLA-RP6AA ₁ .UK	
	Phase , Hz		1 , 50	1 , 50	1 , 50	1 , 50	
	Volts	V	230	230	230	230	
	Amperes	A	0.79	1.25	1.64	1.64	
	Outdoor unit Service Ref.		PU-P3VGAA.UK PU-P3VGAA ₁ .UK PU-P3YGAA.UK PU-P3YGAA ₁ .UK	PU-P4VGAA.UK PU-P4VGAA ₁ .UK PU-P4YGAA.UK PU-P4YGAA ₁ .UK	PU-P5YGAA.UK PU-P5YGAA ₁ .UK	PU-P6YGAA.UK PU-P6YGAA ₁ .UK	
	Phase , Hz		1/3 , 50	1/3 , 50	3 , 50	3 , 50	
	Volts	V	230/400	230/400	400	400	
	Amperes	A	15.55/4.64	16.33/4.59	6.44	7.73	
Refrigerant circuit	Discharge pressure		MPa	2.30	1.98	2.11	2.27
	Suction pressure		MPa	0.47	0.54	0.48	0.45
	Discharge temperature		°C	81	71	71	81
	Condensing temperature		°C	44	42	41	45
	Suction temperature		°C	5	8	6	2
	Ref. pipe length		m	5	5	5	5
Indoor side	Intake air temperature	D.B.	°C	27	27	27	27
		W.B.	°C	19	19	19	19
	Discharge air temperature	D.B.	°C	13.4	14.0	11.7	11.3
Outdoor side	Intake air temperature	D.B.	°C	35	35	35	35
		W.B.	°C	24	24	24	24
SHF			0.74	0.78	0.72	0.69	
BF			0.13	0.12	0.06	0.09	

The unit of pressure has been changed to MPa based on international SI system.
The conversion factor is : 1(MPa)=10.2(kgf/cm²)

6-5. OUTLET AIR SPEED AND COVERAGE RANGE

		PLA-RP1.6AA.UK	PLA-RP2AA.UK	PLA-RP2.5AA.UK	PLA-RP3AA.UK PLA-RP3AA ₁ .UK	PLA-RP4AA.UK PLA-RP4AA ₁ .UK	PLA-RP5AA.UK PLA-RP5AA ₁ .UK	PLA-RP6AA.UK PLA-RP6AA ₁ .UK
Air flow	m ³ /min.	14	18	18	20	28	30	30
Air speed	m/sec.	2.8	3.6	3.6	4.0	4.9	6.6	6.6
Coverage range	m	4.0	5.2	5.2	5.7	7.4	8.9	8.9

* The air coverage range is the value up to the position where the air speed is 0.25m/sec.
When air is blown out horizontally from the unit at the Hi notch position.
The coverage range should be used only as a general guideline since it varies according to the size of the room and the furniture inside the room.

6-6. NOISE CRITERION CURVES

PLA-RP1.6AA.UK

NOTCH	SPL(dB)	LINE
High	31	○—○
Medium1	29	△—△
Medium2	28	●—●
Low	27	▲—▲

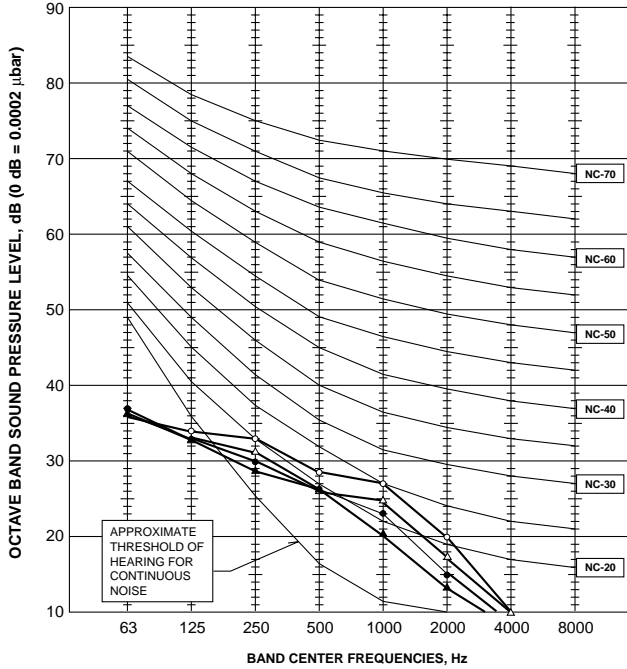

PLA-RP2AA.UK PLA-RP2.5AA.UK

NOTCH	SPL(dB)	LINE
High	33	○—○
Medium1	31	△—△
Medium2	29	●—●
Low	28	▲—▲

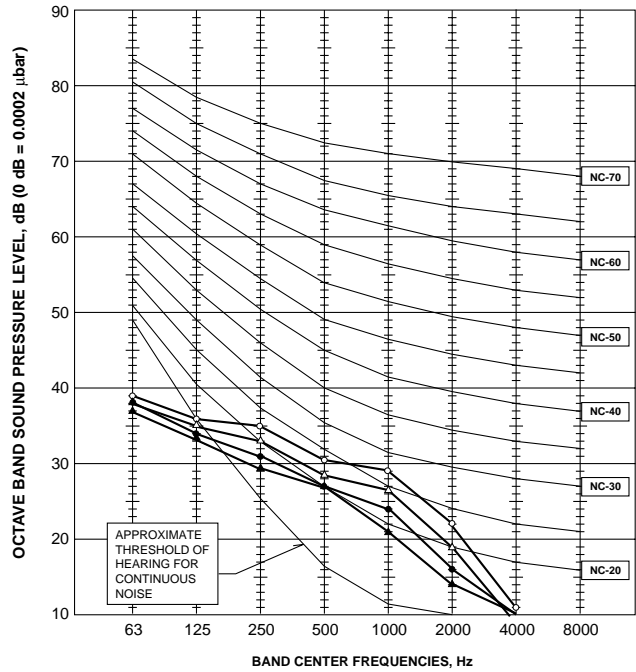

PLA-RP3AA.UK PLA-RP3AA₁.UK

NOTCH	SPL(dB)	LINE
High	34	○—○
Medium1	32	△—△
Medium2	30	●—●
Low	28	▲—▲

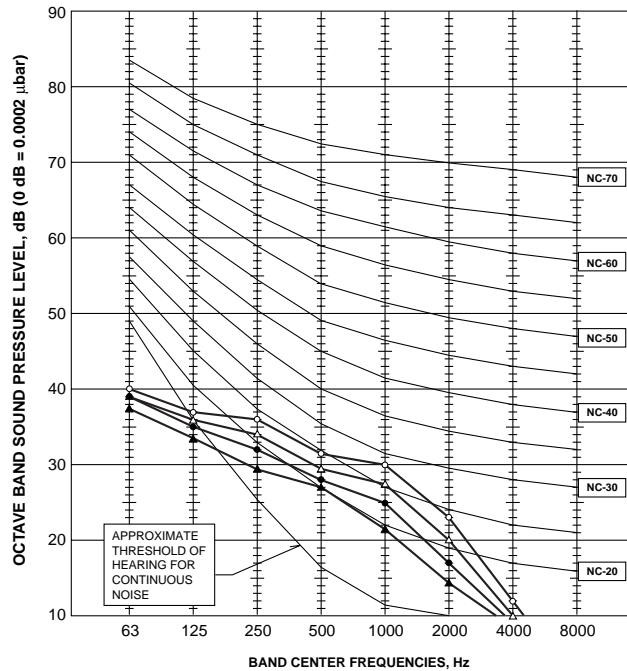

PLA-RP4AA.UK PLA-RP4AA₁.UK

NOTCH	SPL(dB)	LINE
High	41	○—○
Medium1	39	△—△
Medium2	36	●—●
Low	33	▲—▲

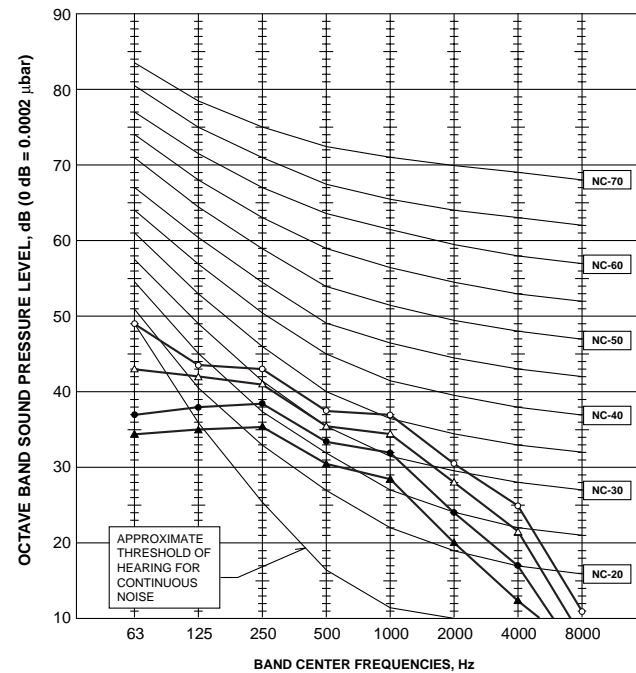

PLA-RP5AA.UK
PLA-RP5AA₁.UK

NOTCH	SPL(dB)	LINE
High	45	○—○
Medium1	43	△—△
Medium2	40	●—●
Low	37	▲—▲

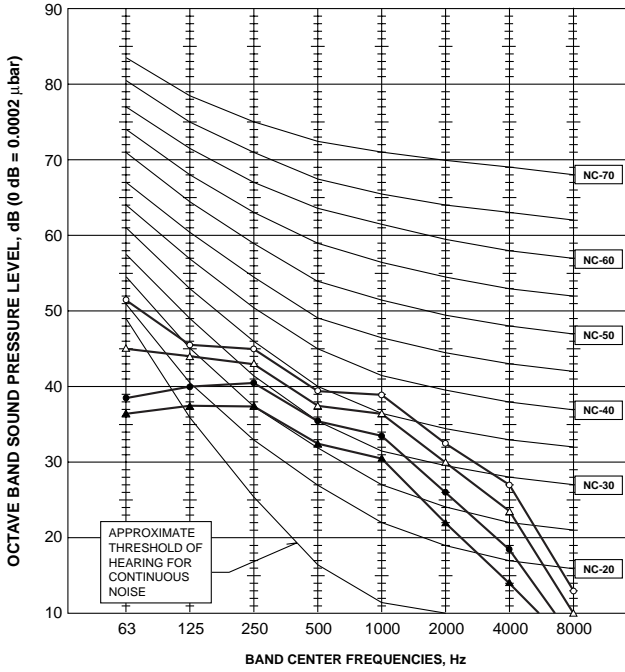

PLA-RP6AA.UK
PLA-RP6AA₁.UK

NOTCH	SPL(dB)	LINE
High	45	○—○
Medium1	43	△—△
Medium2	40	●—●
Low	37	▲—▲

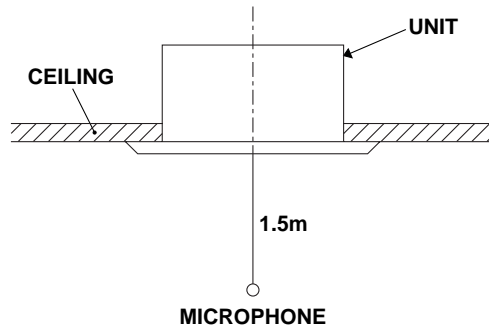
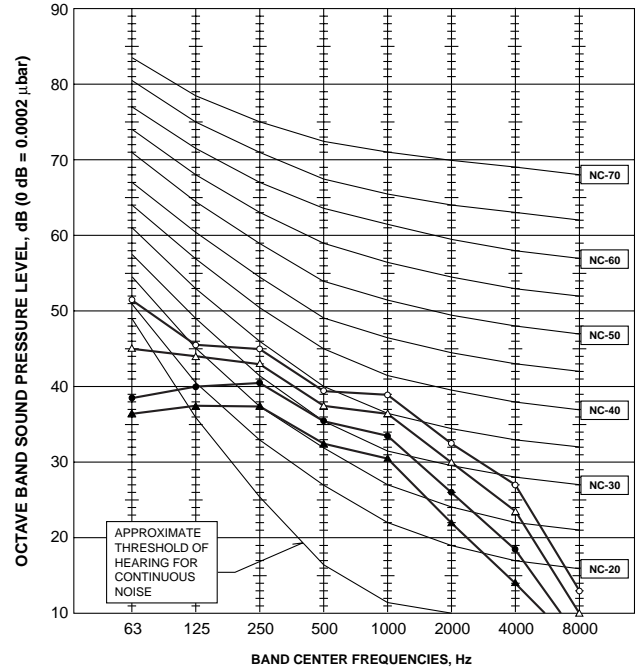

7

OUTLINES AND DIMENSIONS

PLA-RP1.6AA.UK PLA-RP2AA.UK PLA-RP2.5AA.UK
 PLA-RP3AA.UK PLA-RP4AA.UK PLA-RP5AA.UK PLA-RP6AA.UK
 PLA-RP3AA₁.UK PLA-RP4AA₁.UK PLA-RP5AA₁.UK PLA-RP6AA₁.UK

Unit : mm

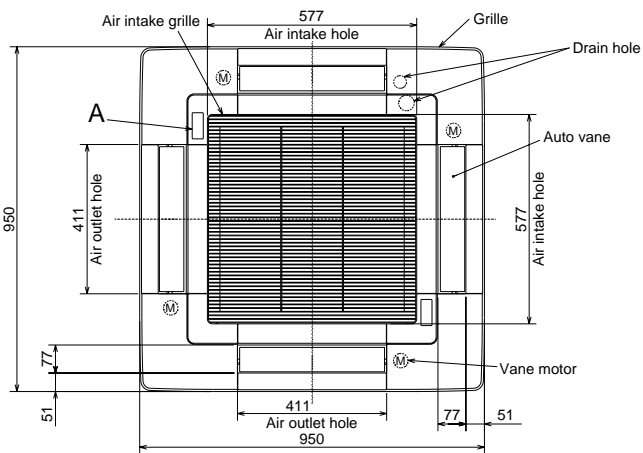
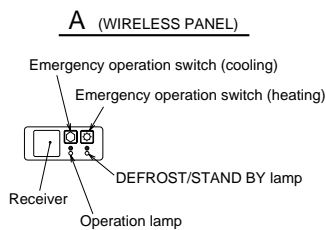
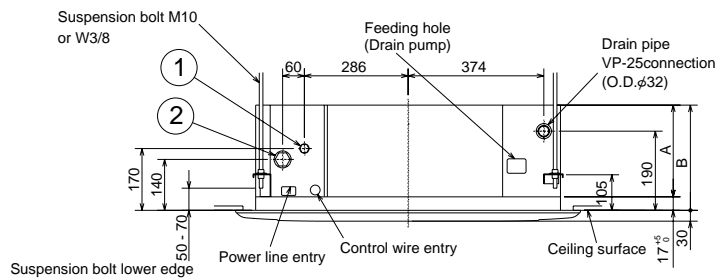
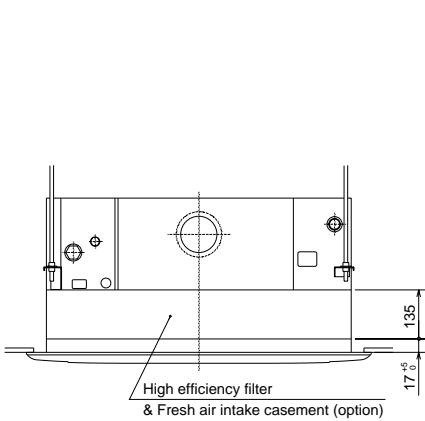
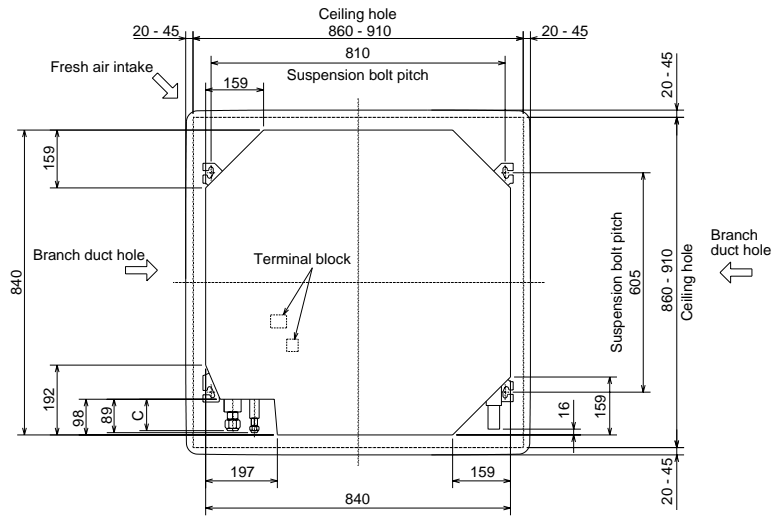
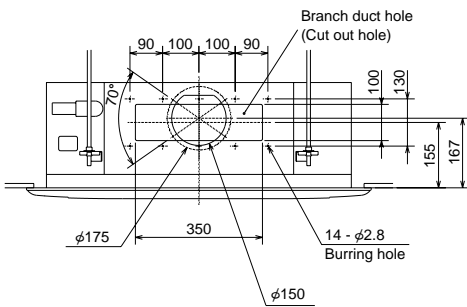

Models	①	②	A	B	C
PLA-RP1.6,2AA	FOR PUHZ-RP type Refrigerant pipe(6.35mm dia.) flared connection 1/4F	FOR PUHZ-RP type Refrigerant pipe(12.7mm dia.) flared connection 1/2F	241	258	80
	FOR PU(H)-P type Refrigerant pipe(9.52mm dia.) flared connection 3/8F	FOR PU(H)-P type Refrigerant pipe(15.88mm dia.) flared connection 5/8F			
PLA-RP2.5,3AA	Refrigerant pipe(9.52mm dia.) flared connection 3/8F	Refrigerant pipe(15.88mm dia.) flared connection 5/8F	281	298	84
PLA-RP4,5,6AA	Refrigerant pipe(9.52mm dia.) flared connection 3/8F	FOR PUHZ-RP type Refrigerant pipe(15.88mm dia.) flared connection 5/8F FOR PU(H)-P type Refrigerant pipe(19.05mm dia.) flared connection 3/4F			

PLA-RP1.6AA.UK PLA-RP2AA.UK PLA-RP2.5AA.UK
 PLA-RP3AA.UK PLA-RP4AA.UK PLA-RP5AA.UK PLA-RP6AA.UK
 PLA-RP3AA₁.UK PLA-RP4AA₁.UK PLA-RP5AA₁.UK PLA-RP6AA₁.UK

[LEGEND]

SYMBOL	NAME	SYMBOL	NAME	SYMBOL	NAME
P.B	INDOOR POWER BOARD	MV	VANE MOTOR	W.B	WIRELESS REMOTE CONTROLLER BOARD
F1	FUSE (4A)	DP	DRAIN PUMP	RU	RECEIVING UNIT
ZNR	VARISTOR	DS	DRAIN SENSOR	BZ	BUZZER
I.B	INDOOR CONTROLLER BOARD	H2	DEW PREVENTION HEATER	LED1	LED (RUN INDICATOR)
CN2L	CONNECTOR (LOSSNAY)	TB4	TERMINAL BLOCK (INDOOR/OUTDOOR CONNECTING LINE)	LED2	LED (HOT ADJUST)
CN32	CONNECTOR (REMOTE SWITCH)	TB5	TERMINAL BLOCK (REMOTE CONTROLLER TRANSMISSION LINE)	SW1	SWITCH (HEATING ON/OFF)
CN41	CONNECTOR (HA TERMINAL-A)	TH1	ROOM TEMPERATURE THERMISTOR (0°C/15kΩ, 25°C/5.4kΩ DETECT)	SW2	SWITCH (COOLING ON/OFF)
SW1	JUMPER WIRE (MODEL SELECTION)	TH2	PIPE TEMPERATURE THERMISTOR/LIQUID (0°C/15kΩ, 25°C/5.4kΩ DETECT)		
SW2	JUMPER WIRE (CAPACITY CORD)	TH5	COND./EVA. TEMPERATURE THERMISTOR (0°C/15kΩ, 25°C/5.4kΩ DETECT)		
SWE	SWITCH (EMERGENCY OPERATION)	R.B	REMOTE CONTROLLER BOARD		
X1	RELAY (DRAIN PUMP)	CN2	CONNECTOR (PROGRAM TIMER)		
X4	RELAY (FAN MOTOR)	TB6	TERMINAL BLOCK (REMOTE CONTROLLER TRANSMISSION LINE)		
FC	FAN PHASE CONTROL				
LED1	POWER SUPPLY (I.B)				
LED2	POWER SUPPLY (I.B)				
LED3	TRANSMISSION (INDOOR-OUTDOOR)				
C	CAPACITOR (FAN MOTOR)				
MF	FAN MOTOR				

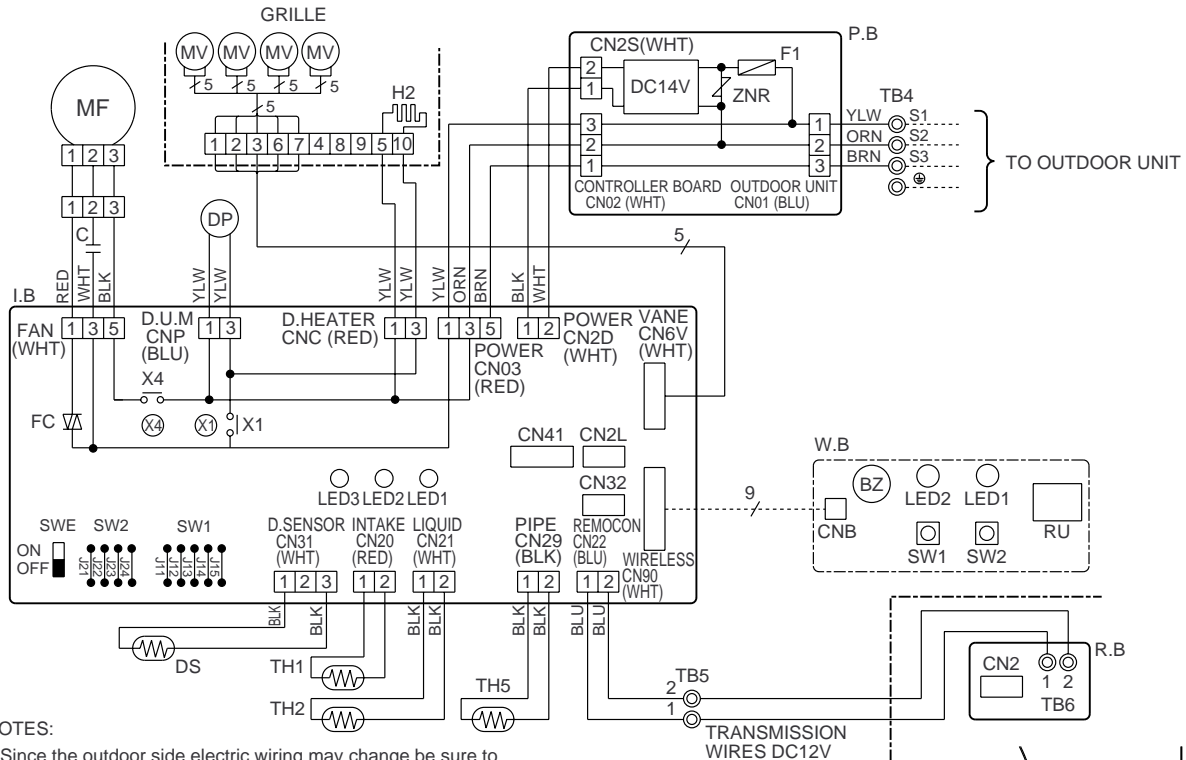

NOTES:

- Since the outdoor side electric wiring may change be sure to check the outdoor unit electric wiring for servicing.
- Indoor and outdoor connecting wires are made with polarities, make wiring matching terminal numbers (S1, S2, S3).
- Symbols used in wiring diagram above are, : Connector, : Terminal (block).

[Servicing]

Fasten terminal of the terminal board "TB4" equips lock system.
 To remove the fastened terminal, pull it while pressing the protruding portion (locking lever) of the terminal. The fastened terminal protruding portion should face upward.

Please set the voltage using the remote controller. For the setting method, please refer to the indoor unit Installation Manual.

SW1		
MODELS	Manufacture	Service board
PLA-RP1.6,2,2.5AA.UK PLA-RP3,4,5,6AA.UK PLA-RP3,4,5,6AA ₁ .UK		

SW2					
MODELS	Manufacture	Service board	MODELS	Manufacture	Service board
PLA-RP1.6AA.UK	J21,J22,J23,J24		PLA-RP4AA.UK PLA-RP4AA ₁ .UK	J21,J22,J23,J24	
PLA-RP2AA.UK	J21,J22,J23,J24		PLA-RP5AA.UK	J21,J22,J23,J24	
PLA-RP2.5AA.UK	J21,J22,J23,J24		PLA-RP5AA ₁ .UK PLA-RP6AA.UK PLA-RP6AA ₁ .UK	J21,J22,J23,J24	
PLA-RP3AA.UK PLA-RP3AA ₁ .UK	J21,J22,J23,J24				

REFRIGERANT SYSTEM DIAGRAM

PLA-RP1.6AA.UK PLA-RP2AA.UK PLA-RP2.5AA.UK
 PLA-RP3AA.UK PLA-RP4AA.UK PLA-RP5AA.UK PLA-RP6AA.UK
 PLA-RP3AA₁.UK PLA-RP4AA₁.UK PLA-RP5AA₁.UK PLA-RP6AA₁.UK

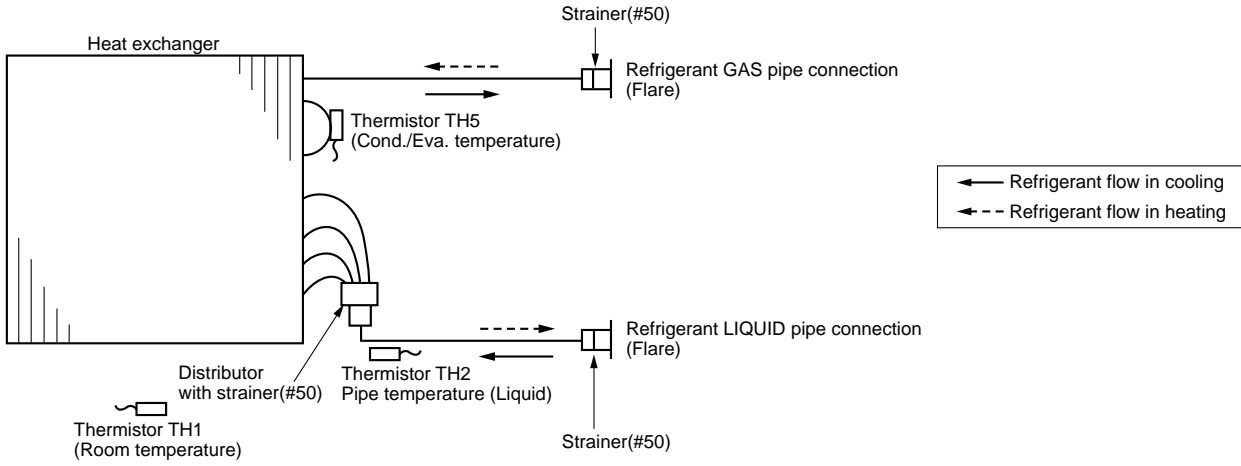

10-1. TROUBLESHOOTING

<Error code display by self-diagnosis and actions to be taken for service (summary)>

Present and past error codes are logged and displayed on the wired remote controller and control board of outdoor unit. Actions to be taken for service, which depends on whether or not the inferior phenomenon is reoccurring at service, are summarised in the table below. Check the contents below before investigating details.

Note : Refer to the manual of outdoor unit for malfunction-diagnosis method by remote controller.

Unit conditions at service	Error code	Actions to be taken for service (summary)
The inferior phenomenon is reoccurring.	Displayed	Judge what is wrong and take a corrective action according to 10-2. "Self-diagnosis action table".
	Not displayed	Conduct trouble shooting and ascertain the cause of the inferior phenomenon according to 10-3. "Trouble shooting by inferior phenomena".
The inferior phenomenon is not reoccurring.	Logged	<ul style="list-style-type: none"> ① Consider the temporary defects such as the work of protection devices in the refrigerant circuit including compressor, poor connection of wiring, noise and etc. Re-check the symptom, and check the installation environment, refrigerant amount, weather when the inferior phenomenon occurred, matters related to wiring and etc. ② Reset error code logs and restart the unit after finishing service. ③ There is no abnormality concerning of parts such as electrical component, controller board, remote controller and etc.
	Not logged	<ul style="list-style-type: none"> ① Recheck the abnormal symptom. ② Conduct trouble shooting and ascertain the cause of the inferior phenomenon according to 10-3. "Trouble shooting by inferior phenomena". ③ Continue to operate unit for the time being if the cause is not ascertained. ④ There is no abnormality concerning of parts such as electrical component, controller board, remote controller and etc.

Note: Refer to the manual of outdoor unit for the details of display such as F, U, and other E.

10-2. SELF-DIAGNOSIS ACTION TABLE

Error Code	Meaning of error code and detection method	Case	Judgment and action
P1	<p>Abnormality of room temperature thermistor (TH1)</p> <p>① The unit is in three-minute resume prevention mode if short/open of thermistor is detected. Abnormal if the unit does not reset normally after three minutes. (The unit returns to normal operation, if it has normally reset.)</p> <p>② Constantly detected during cooling, drying, and heating operation. Short: 90°C or more Open: -40°C or less</p>	<p>① Defective thermistor characteristics.</p> <p>② Contact failure of connector (CN20) on the indoor controller board. (Insert failure)</p> <p>③ Breaking of wire or contact failure of thermistor wiring.</p> <p>④ Defective indoor controller board.</p>	<p>①—③ Check resistance value of thermistor. 0°C15.0kΩ 10°C9.6kΩ 20°C6.3kΩ 30°C4.3kΩ 40°C3.0kΩ If you put force on (draw or bend) the lead wire with measuring resistance value of thermistor breaking of wire or contact failure can be detected.</p> <p>② Check contact failure of connector (CN20) on the indoor controller board. Refer to 10-6-2. Put the power on again and check restart after inserting connector again.</p> <p>④ Check room temperature display on remote controller. Replace indoor controller board if there is abnormal difference with actual room temperature. There is no abnormality if none of above comes within the unit. Put the power off, and on again to operate.</p>
P2	<p>Abnormality of pipe temperature thermistor/Liquid (TH2)</p> <p>① The unit is in three-minute resume prevention mode if short/open of thermistor is detected. Abnormal if the unit does not reset normally after three minutes. (The unit returns to normal operation, if it has normally reset.)</p> <p>② Constantly detected during cooling, drying, and heating (except defrosting) operation. Short: 90°C or more Open: -40°C or less</p>	<p>① Defective thermistor characteristics.</p> <p>② Contact failure of connector (CN21) on the indoor controller board. (Insert failure)</p> <p>③ Breaking of wire or contact failure of thermistor wiring.</p> <p>④ Defective refrigerant circuit is causing thermistor temperature of 90°C or more or -40°C or less.</p> <p>⑤ Defective indoor controller board.</p>	<p>①—③ Check resistance value of thermistor. For characteristics, refer to (P1) above.</p> <p>② Check contact failure of connector (CN21) on the indoor controller board. Refer to 10-6-2. Put the power on and check restart after inserting connector again.</p> <p>④ Check pipe <liquid> temperature with remote controller in test run mode. If pipe <liquid> temperature is exclusively low (in cooling mode) or high (in heating mode), refrigerant circuit may have defective.</p> <p>⑤ Check pipe <liquid> temperature with remote controller in test run mode. If there is exclusive difference with actual pipe <liquid> temperature, replace indoor controller board. There is no abnormality if none of above comes within the unit. Put the power off, and on again to operate.</p>
P4	<p>Abnormality of drain sensor (DS)</p> <p>① Suspensive abnormality, if short/open of thermistor is detected for 30 seconds continuously. Put off compressor and indoor fan.</p> <p>② Short/open is detected for 30 seconds continuously during suspensive abnormality. (The unit returns to normal operation, if it has normally reset.)</p> <p>③ Detect the following condition.</p> <ul style="list-style-type: none"> • During cooling and drying operation. • In case that pipe <liquid> temperature - room temperature <-10deg (Except defrosting) • When pipe <liquid> temperature or room temperature is short/open temperature. • During drain pump operation. 	<p>① Defective thermistor characteristics</p> <p>② Contact failure of connector (CN31) on the indoor controller board. (Insert failure).</p> <p>③ Breaking of wire or contact failure of drain sensor wiring.</p> <p>④ Defective indoor controller board.</p>	<p>①—③ Check resistance value of thermistor. 0°C6.0kΩ 10°C3.9kΩ 20°C2.6kΩ 30°C1.8kΩ 40°C1.3kΩ</p> <p>② Check contact failure of connector (CN31) on the indoor controller board. Refer to 10-6-2. Put the power on again and check restart after inserting connector again.</p> <p>④ Replace indoor controller board if drain pump operates with the line of drain sensor connector CN31-① and ② is short-circuited, and abnormality reappears. There is no abnormality if none of above comes within the unit. Put the power off, and on again to operate.</p>
P5	<p>Malfunction of drain pump (DP)</p> <p>① Suspensive abnormality, if thermistor of drain sensor is let heat itself and temperature rises slightly. Put off compressor and indoor fan.</p> <p>② Drain pump is abnormal if the condition above is detected during suspensive abnormality.</p> <p>③ Constantly detected during drain pump operation.</p>	<p>① Malfunction of drain pump</p> <p>② Defective drain Clogged drain pump Clogged drain pipe</p> <p>③ Attached drop of water at the drain sensor</p> <ul style="list-style-type: none"> • Drops of drain trickles from lead wire. • Clogged filter is causing wave of drain. <p>④ Defective indoor controller board.</p>	<p>① Check if drain-up machine works.</p> <p>② Check drain function.</p> <p>③ Check the setting of lead wire of drain sensor and check clogs of the filter.</p> <p>④ Replace indoor controller board if drain pump operates with the line of drain sensor connector CN31-① and ② is short-circuited and abnormality reappears. Refer to 10-6-2. There is no abnormality if none of above comes within the unit. Put the power off, and on again to operate.</p>

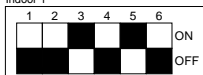
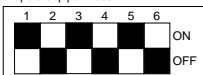
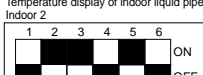
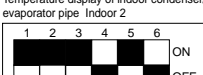

Error Code	Meaning of error code and detection method	Case	Judgment and action
P6	<p>Freezing/overheating protection is working</p> <p>① Freezing protection (Cooling mode) The unit is in six-minute resume prevention mode if pipe <liquid or condenser/evaporator> temperature stays under -15°C for three minutes, three minutes after the compressor started. Abnormal if it stays under -15°C for three minutes again within 16 minutes after six-minute resume prevention mode.</p> <p>② Overheating protection (Heating mode) The units is in six-minute resume prevention mode if pipe <condenser / evaporator> temperature is detected as over 74°C after the compressor started. Abnormal if the temperature of over 74°C is detected again within 10 minutes after six-minute resume prevention mode.</p>	<p>(Cooling or drying mode)</p> <p>① Clogged filter (reduced airflow) ② Short cycle of air path ③ Low-load (low temperature) operation beyond the tolerance range ④ Defective indoor fan motor</p> <ul style="list-style-type: none"> • Fan motor is defective. • Indoor controller board is defective. <p>⑤ Overcharge of refrigerant ⑥ Defective refrigerant circuit (clogs)</p> <p>(Heating mode)</p> <p>① Clogged filter (reduced airflow) ② Short cycle of air path ③ Over-load (high temperature) operation beyond the tolerance range ④ Defective indoor fan motor</p> <ul style="list-style-type: none"> • Fan motor is defective. • Indoor controller board is defective. <p>⑤ Overcharge of refrigerant ⑥ Defective refrigerant circuit (clogs) ⑦ Bypass circuit of outdoor unit is defective.</p>	<p>(Cooling or drying mode)</p> <p>① Check clogs of the filter. ② Remove shields.</p> <p>④ Measure the resistance of fan motor's winding. Measure the output voltage of fan's connector (FAN) on the indoor controller board. *The indoor controller board should be normal when voltage of AC 100~240V is detected while fan motor is connected. Refer to 10-6-2. ⑤⑥ Check operating condition of refrigerant circuit.</p> <p>(Heating mode)</p> <p>① Check clogs of the filter. ② Remove shields.</p> <p>④ Measure the resistance of fan motor's winding. Measure the output voltage of fan's connector (FAN) on the indoor controller board. *The indoor controller board should be normal when voltage of AC 100~240V is detected while fan motor is connected. Refer to 10-6-2. ⑤~⑦ Check operating condition of refrigerant circuit.</p>
P8	<p>Abnormality of pipe temperature</p> <p><Cooling mode> Detected as abnormal when the pipe temperature is not in the cooling range 3 minutes later of compressor start and 6 minutes later of the liquid or condenser/evaporator pipe is out of cooling range. Note 1) It takes at least 9 min. to detect. Note 2) Abnormality P8 is not detected in drying mode. Cooling range : Indoor pipe temperature (TH2 or TH5) – intake temperature (TH1) ≤ -3 deg TH: Lower temperature between: liquid pipe temperature and condenser/evaporator temperature</p> <p><Heating mode> When 10 seconds have passed after the compressor starts operation and the hot adjustment mode has finished, the unit is detected as abnormal when condenser/evaporator pipe temperature is not in heating range within 20 minutes.</p> <p>Note 3) It takes at least 27 minutes to detect abnormality. Note 4) It excludes the period of defrosting (Detection restarts when defrosting mode is over) Heating range : 3 deg ≤ (Condenser/ Evaporator temperature(TH5) – intake temperature(TH1))</p>	<p>① Slight temperature difference between indoor room temperature and pipe <liquid or condenser / evaporator> temperature thermistor</p> <ul style="list-style-type: none"> • Shortage of refrigerant • Disconnected holder of pipe <liquid or condenser / evaporator> thermistor • Defective refrigerant circuit <p>② Converse connection of extension pipe (on plural units connection) ③ Converse wiring of indoor/outdoor unit connecting wire (on plural units connection) ④ Defective detection of indoor room temperature and pipe <condenser / evaporator> temperature thermistor ⑤ Stop valve is not opened completely.</p>	<p>①~④ Check pipe <liquid or condenser / evaporator> temperature with room temperature display on remote controller and outdoor controller circuit board. Pipe <liquid or condenser / evaporator> temperature display is indicated by setting SW2 of outdoor controller circuit board as follows.</p> <p>(Conduct temperature check with outdoor controller circuit board after connecting 'A-Control Service Tool(PAC-SK52ST)')</p> <div style="display: flex; justify-content: space-around;"> <div style="text-align: center;"> <p>Temperature display of indoor liquid pipe Indoor 1</p>  </div> <div style="text-align: center;"> <p>Temperature display of indoor condenser/evaporator pipe Indoor 1</p>  </div> </div> <div style="display: flex; justify-content: space-around;"> <div style="text-align: center;"> <p>Temperature display of indoor liquid pipe Indoor 2</p>  </div> <div style="text-align: center;"> <p>Temperature display of indoor condenser/evaporator pipe Indoor 2</p>  </div> </div> <p style="text-align: center; font-size: small;">A-Control Service Tool SW2 setting</p> <p>②③ Check converse connection of extension pipe or converse wiring of indoor/outdoor unit connecting wire.</p>

Error Code	Meaning of error code and detection method	Case	Judgment and action
P9	<p>Abnormality of pipe temperature thermistor / Condenser-Evaporator (TH5)</p> <p>① The unit is in three-minute resume protection mode if short/open of thermistor is detected. Abnormal if the unit does not get back to normal within three minutes. (The unit returns to normal operation, if it has normally reset.)</p> <p>② Constantly detected during cooling, drying, and heating operation (except defrosting) Short: 90°C or more Open: -40°C or less</p>	<p>① Defective thermistor characteristics</p> <p>② Contact failure of connector (CN29) on the indoor controller board. (Insert failure)</p> <p>③ Breaking of wire or contact failure of thermistor wiring.</p> <p>④ Temperature of thermistor is 90°C or more or -40°C or less caused by defective refrigerant circuit.</p> <p>⑤ Defective indoor controller board.</p>	<p>①-③ Check resistance value of thermistor. For characteristics, refer to (P1) above.</p> <p>② Check contact failure of connector (CN29) on the indoor controller board. Refer to 10-6-2. Put the power on and check restart after inserting connector again.</p> <p>④ Operate in test run mode and check pipe <condenser / evaporator> temperature with outdoor controller circuit board. If pipe <condenser / evaporator> temperature is exclusively low (in cooling mode) or high (in heating mode), refrigerant circuit may have defective.</p> <p>⑤ Operate in test run mode and check pipe <condenser / evaporator> temperature with outdoor control circuit board. If there is exclusive difference with actual pipe <condenser / evaporator> temperature replace indoor controller board. There is no abnormality if none of above comes within the unit. Put the power off and on again to operate.</p> <p>(In case of checking pipe temperature with outdoor controller circuit board, be sure to connect A-control service tool (PAC-SK52ST).)</p> <div style="display: flex; justify-content: space-around;"> <div style="text-align: center;"> <p>Temperature display of indoor condenser/ evaporator pipe Indoor 1</p> </div> <div style="text-align: center;"> <p>Temperature display of indoor condenser/ evaporator pipe Indoor 2</p> </div> </div> <p style="text-align: center;">A-Control Service Tool SW2 setting</p>
E4	<p>Remote controller signal receiving error</p> <p>① Abnormal if indoor controller board can not receive normally any data from remote controller or from other indoor controller board for three minutes.</p> <p>② Indoor control board cannot receive any signal from remote controller for two minutes.</p>	<p>① Contact failure at transmission wire of remote controller</p> <p>② All remote controllers are set as "sub" remote controller. In this case, E0 is displayed on remote controller, and E4 is displayed at LED (LED1, LED2) on the outdoor controller circuit board.</p> <p>③ Defective transmitting receiving circuit of remote controller</p> <p>④ Defective transmitting receiving circuit of indoor controller board.</p> <p>⑤ Noise has entered into the transmission wire of remote controller.</p>	<p>① Check disconnection or looseness of indoor unit or transmission wire of remote controller.</p> <p>② Set one of the remote controllers "main". If there is no problem with the action above.</p> <p>③ Diagnose remote controllers. a) When "RC OK" is displayed, Remote controllers have no problem. Put the power off, and on again to check. If abnormality generates again, replace indoor controller board. b) When "RC NG" is displayed, Replace remote controller. c) When "RC E3" is displayed, d) When "ERC 00-06" is displayed, [c),d)→Noise may be causing abnormality.] * If the unit is not normal after replacing indoor controller board in group control, indoor controller board of address "0" may be abnormal.</p>
E5	<p>Remote controller transmitting error</p> <p>① Abnormal if indoor controller board cannot check the blank of transmission path for three minutes.</p> <p>② Abnormal if indoor controller board cannot finish transmitting 30 times consecutively.</p>	<p>① Defective transmitting receiving circuit of indoor controller board.</p> <p>② Noise has entered into the transmission wire of remote controller.</p>	<p>①② Put the power off, and on again to check. If abnormality generates again, replace indoor controller board.</p>
E6	<p>Indoor/outdoor unit communication error (Signal receiving error)</p> <p>① Abnormal if indoor controller board cannot receive any signal normally for six minutes after putting the power on.</p> <p>② Abnormal if indoor controller board cannot receive any signal normally for three minutes.</p> <p>③ Consider the unit abnormal under the following condition: When two or more indoor units are connected to one outdoor unit, indoor controller board cannot receive a signal for three minutes from outdoor controller circuit board, a signal which allows outdoor controller circuit board to transmit signals.</p>	<p>① Contact failure, short circuit or, mis-wiring (converse wiring) of indoor/outdoor unit connecting wire</p> <p>② Defective transmitting receiving circuit of indoor controller board</p> <p>③ Defective transmitting receiving circuit of indoor controller board</p> <p>④ Noise has entered into indoor/ outdoor unit connecting wire.</p>	<p>* Check LED display on the outdoor control circuit board. (Connect A-control service tool, PAC-SK52ST.) Refer to EA-EC item if LED displays EA-EC.</p> <p>① Check disconnection or looseness of indoor/ outdoor unit connecting wire of indoor/ outdoor unit. Check all the units in case of twin triple indoor unit system.</p> <p>②-④ Put the power off, and on again to check. If abnormality generates again, replace indoor controller board or outdoor controller circuit board.</p> <p>* Other indoor controller board may have defective in case of twin triple indoor unit system.</p>
E7	<p>Indoor/outdoor unit communication error (Transmitting error)</p> <p>Abnormal if "1" receiving is detected 30 times continuously though indoor controller board has transmitted "0".</p>	<p>① Defective transmitting receiving circuit of indoor controller board</p> <p>② Noise has entered into power supply.</p> <p>③ Noise has entered into outdoor control wire.</p>	<p>①-③ Put the power off, and on again to check. If abnormality generates again, replace indoor controller board.</p>



10-3. TROUBLESHOOTING BY INFERIOR PHENOMENA

Note: Refer to the manual of outdoor unit for the detail of remote controller.

Phenomena	Factor	Countermeasure
(1)LED2 on indoor controller board is off.	<ul style="list-style-type: none"> • When LED1 on indoor controller board is also off. ① Power supply of 220~240V is not supplied to outdoor unit. ② Defective outdoor controller circuit board. ③ Power supply of 220~240V is not supplied to indoor unit. ④ Defective indoor power board. ⑤ Defective indoor controller board. 	<ul style="list-style-type: none"> ① Check the voltage of outdoor power supply terminal block (L, N) <ul style="list-style-type: none"> • When AC 220~240V is not detected. Check the power wiring to outdoor unit and the breaker. • When AC 220~240V is detected. —Check ② (below). ② Check the voltage between outdoor terminal block S1 and S2. <ul style="list-style-type: none"> • When AC 220~240V is not detected. Check the fuse on outdoor controller circuit board (10A). Check the wiring connection. • When AC 220~240V is detected. —Check ③ (below). ③ Check the voltage between indoor terminal block S1 and S2. <ul style="list-style-type: none"> • When AC 220~240V is not detected. Check indoor/outdoor unit connecting wire for mis-wiring. • When AC 220~240V is detected. —Check ④ (below). ④ Check voltage output from CN2S on indoor power board (DC14V). Refer to 10-6-1. <ul style="list-style-type: none"> • When no voltage is output. Check the fuse on indoor power board. Check the wiring connection. • When output voltage is between 12V and 16V. —Check ⑤ (below). ⑤ Check the wiring connection between indoor controller board and indoor power board. If no problems are found, indoor controller board is defective.
(2)LED2 on indoor controller board is blinking.	<ul style="list-style-type: none"> • When LED1 on indoor controller board is also blinking. Connection failure of indoor/outdoor unit connecting wire • When LED1 is lit. Mis-wiring of remote controller wires Under twin triple indoor unit system, 2 or more indoor units are wired together. ① Refrigerant address for outdoor unit is wrong or not set. Under grouping control system, there are some units whose refrigerant address is 0. ② Short-cut of remote controller wires ③ Defective remote controller 	<ul style="list-style-type: none"> Check indoor/outdoor unit connecting wire for connection failure. Check the connection of remote controller wires in case of twin triple indoor unit system. When 2 or more indoor units are wired in one refrigerant system, connect remote controller wires to one of those units. ① Check the setting of refrigerant address in case of grouping control system. If there are some units whose refrigerant addresses are 0 in one group, set one of the units to 0 using SW1 on outdoor controller circuit board. ②③ Remove remote controller wires and check LED2 on indoor controller board. <ul style="list-style-type: none"> • When LED2 is blinking, check the short-cut of remote controller wires. • When LED2 is lit, connect remote controller wires again and: if LED2 is blinking, remote controller is defective; if LED2 is lit, connection failure of remote controller terminal block etc. has returned to normal.
(3)Upward/downward vane performance failure	<ul style="list-style-type: none"> ① The vane is not downward during defrosting and heat preparation and when the thermostat is OFF in HEAT mode. (Working of COOL protection function) ② Vane motor does not rotate. <ul style="list-style-type: none"> • Defective vane motor • Breaking of wire or connection failure of connector ③ Upward/downward vane does not work. <ul style="list-style-type: none"> • The vane is set to fixed position. 	<ul style="list-style-type: none"> ① Normal operation (The vane is set to horizontal regardless of remote control.) ② Check ② (left). <ul style="list-style-type: none"> • Check the vane motor. (Refer to "How to check the parts".) • Check for breaking of wire or connection failure of connector. ③ Normal operation (Each connector on vane motor side is disconnected.)

10-4. EMERGENCY OPERATION

10-4-1. When wireless remote controller troubles or its battery is exhausted

- Emergency operation is available in such a case using emergency operation switch equipped next to the receiver of indoor unit.
 - To start operation
 - Cooling Operation.....Press  (Cooling) switch.
 - Heating Operation.....Press  (Heating) switch.
- ※When the unit starts operating, the operation lamp is lit.

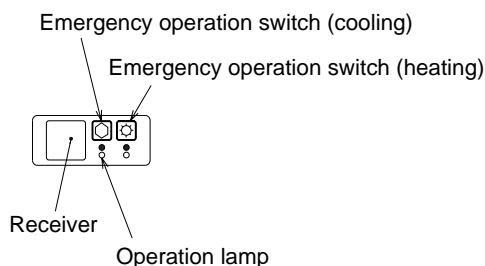

※Emergency operation will be performed as follows.

Mode	Cooling	Heating
Set temperature	24°C	24°C
Fan speed	High	High
Airflow direction	Horizontal (30deg)	Downward (70deg)

- To stop operation
 - Press either emergency operation switch (cooling/heating).

10-4-2. When wired remote controller or indoor unit micro computer troubles

- If there is not any other wrong when trouble occurs, emergency operation starts as the indoor controller board switch (SWE) is set to ON.
During the emergency operation the indoor unit is as follows;
 - Indoor fan high speed operation
 - Drain pump operation
- When emergency operating for COOL or HEAT, setting of the switch (SWE) in the indoor controller board and outdoor unit emergency operation are necessary.
- Check items and notices as the emergency operation
 - Emergency operation cannot be used as follows;
 - When the outdoor unit is something wrong.
 - When the indoor fan is something wrong.
 - When drain over flow protected operation is detected during self-diagnosis. (Error code : P5)
 - Emergency operation will be serial operation by the power supply ON/OFF.
ON/OFF or temperature, etc. adjustment is not operated by the remote controller.
 - Do not operate for a long time as cold air is blown when the outdoor unit starts defrosting operation during heat emergency operation.
 - Cool emergency operation must be within 10 hours at most. It may cause heat exchanger frosting in the indoor unit.
 - After completing the emergency operation, return the switch setting, etc. in former state.
 - Since vane does not work at emergency operation, position the vane manually and slowly.

10-5. HOW TO CHECK THE PARTS

PLA-RP1.6AA.UK

PLA-RP2AA.UK

PLA-RP2.5AA.UK

PLA-RP3AA.UK PLA-RP3AA₁.UK

PLA-RP4AA.UK PLA-RP4AA₁.UK

PLA-RP5AA.UK PLA-RP5AA₁.UK

PLA-RP6AA.UK PLA-RP6AA₁.UK

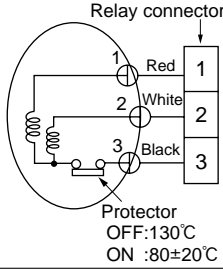
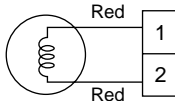
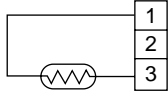
Parts name	Check points													
Room temperature thermistor (TH1) Pipe temperature thermistor/liquid(TH2) Condenser/Evaporator temperature thermistor (TH5)	Disconnect the connector then measure the resistance using a tester. (Surrounding temperature 10°C ~30°C) <table border="1" style="margin-left: 20px;"> <tr> <td>Normal</td> <td>Abnormal</td> </tr> <tr> <td>4.3kΩ~9.6kΩ</td> <td>Open or short</td> </tr> </table> (Refer to the thermistor)	Normal	Abnormal	4.3kΩ~9.6kΩ	Open or short									
Normal	Abnormal													
4.3kΩ~9.6kΩ	Open or short													
Vane motor	Measure the resistance between the terminals using a tester. (Surrounding temperature 20°C) <table border="1" style="margin-left: 20px;"> <tr> <td>Normal</td> <td>Abnormal</td> </tr> <tr> <td>15kΩ</td> <td>Open or short</td> </tr> </table>	Normal	Abnormal	15kΩ	Open or short									
Normal	Abnormal													
15kΩ	Open or short													
Fan motor 	Measure the resistance between the terminals using a tester. (Winding temperature 20°C) <table border="1" style="margin-left: 20px;"> <thead> <tr> <th rowspan="2">Motor terminal or Relay connector</th> <th colspan="2">Normal</th> <th rowspan="2">Abnormal</th> </tr> <tr> <th>PLA-RP1.6,2,2.5,3AA.UK PLA-RP3AA₁.UK</th> <th>PLA-RP4,5,6AA.UK PLA-RP4,5,6AA₁.UK</th> </tr> </thead> <tbody> <tr> <td>Red-Black</td> <td>87.2Ω</td> <td>28.7Ω</td> <td rowspan="2">Open or short</td> </tr> <tr> <td>White-Black</td> <td>104.1Ω</td> <td>41.6Ω</td> </tr> </tbody> </table>	Motor terminal or Relay connector	Normal		Abnormal	PLA-RP1.6,2,2.5,3AA.UK PLA-RP3AA ₁ .UK	PLA-RP4,5,6AA.UK PLA-RP4,5,6AA ₁ .UK	Red-Black	87.2Ω	28.7Ω	Open or short	White-Black	104.1Ω	41.6Ω
Motor terminal or Relay connector	Normal		Abnormal											
	PLA-RP1.6,2,2.5,3AA.UK PLA-RP3AA ₁ .UK	PLA-RP4,5,6AA.UK PLA-RP4,5,6AA ₁ .UK												
Red-Black	87.2Ω	28.7Ω	Open or short											
White-Black	104.1Ω	41.6Ω												
Drain pump 	Measure the resistance between the terminals using a tester. (Winding temperature 20°C) <table border="1" style="margin-left: 20px;"> <tr> <td>Normal</td> <td>Abnormal</td> </tr> <tr> <td>290Ω</td> <td>Open or short</td> </tr> </table>	Normal	Abnormal	290Ω	Open or short									
Normal	Abnormal													
290Ω	Open or short													
Drain sensor 	Measure the resistance between the terminals using a tester. Measure the resistance after 3 minutes have passed since the power supply was intercepted. (Surrounding temperature 0°C ~60°C) <table border="1" style="margin-left: 20px;"> <tr> <td>Normal</td> <td>Abnormal</td> </tr> <tr> <td>0.6kΩ~6.0kΩ</td> <td>Open or short</td> </tr> </table> (Refer to the thermistor)	Normal	Abnormal	0.6kΩ~6.0kΩ	Open or short									
Normal	Abnormal													
0.6kΩ~6.0kΩ	Open or short													

<Thermistor Characteristic graph>

Thermistor for lower temperature

Room temperature thermistor (TH1)
 Pipe temperature thermistor/liquid (TH2)
 Condenser/evaporator temperature thermistor (TH5)

Thermistor $R_0 = 15k\Omega \pm 3\%$

Fixed number of $B = 3480K \pm 2\%$

$$R_t = 15 \exp \left\{ 3480 \left(\frac{1}{273+t} - \frac{1}{273} \right) \right\}$$

0°C	15kΩ
10°C	9.6kΩ
20°C	6.3kΩ
25°C	5.4kΩ
30°C	4.3kΩ
40°C	3.0kΩ

Thermistor for drain sensor

Thermistor $R_0 = 6.0k\Omega \pm 5\%$

Fixed number of $B = 3390K \pm 2\%$

$$R_t = 6 \exp \left\{ 3390 \left(\frac{1}{273+t} - \frac{1}{273} \right) \right\}$$

0°C	6.0kΩ
10°C	3.9kΩ
20°C	2.6kΩ
25°C	2.2kΩ
30°C	1.8kΩ
40°C	1.3kΩ

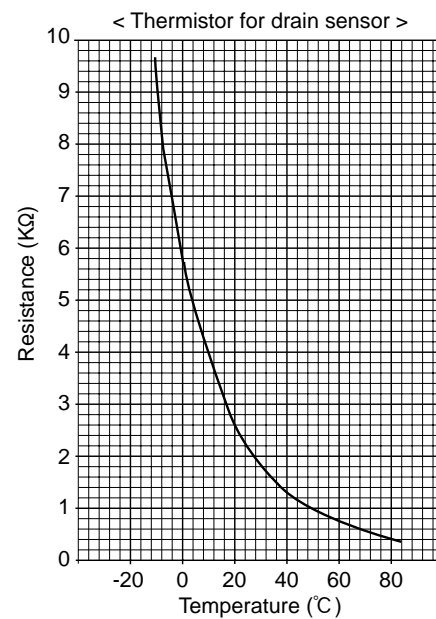
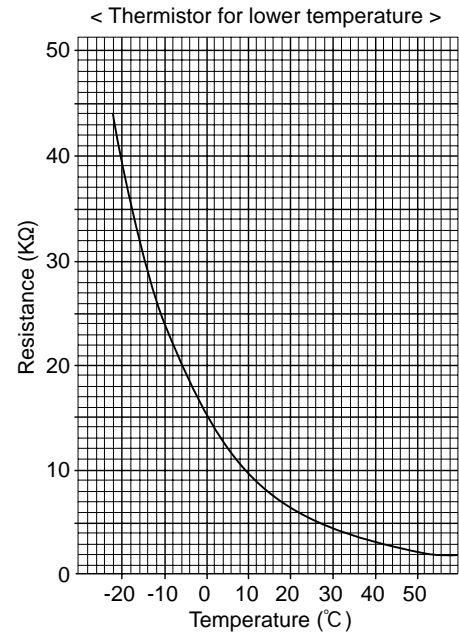

10-6. TEST POINT DIAGRAM

10-6-1. Power board

PLA-RP1.6AA.UK

PLA-RP2AA.UK

PLA-RP2.5AA.UK

PLA-RP3AA.UK PLA-RP3AA₁.UK

PLA-RP4AA.UK PLA-RP4AA₁.UK

PLA-RP5AA.UK PLA-RP5AA₁.UK

PLA-RP6AA.UK PLA-RP6AA₁.UK

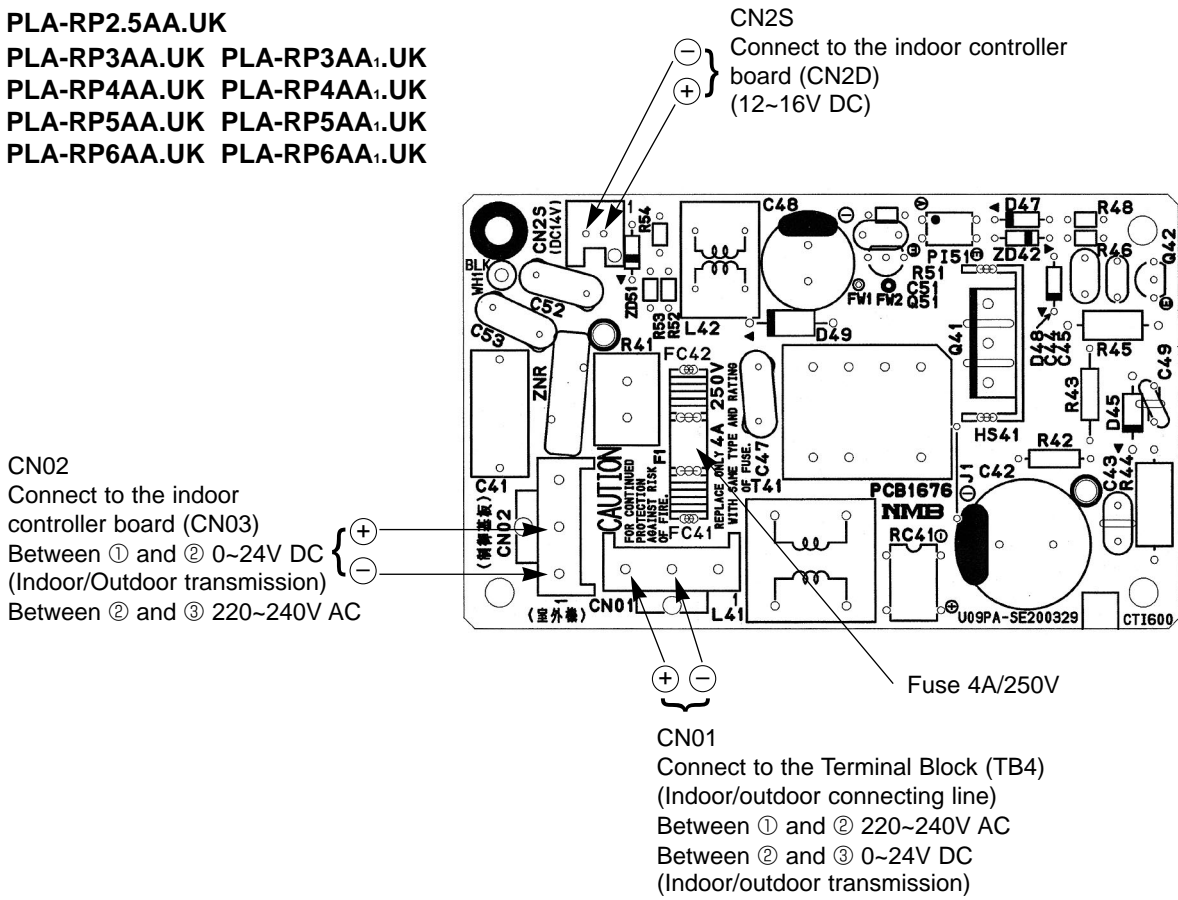

10-6-2. Controller board

PLA-RP1.6AA.UK

PLA-RP2AA.UK

PLA-RP2.5AA.UK

PLA-RP3AA.UK PLA-RP3AA₁.UK

PLA-RP4AA.UK PLA-RP4AA₁.UK

PLA-RP5AA.UK PLA-RP5AA₁.UK

PLA-RP6AA.UK PLA-RP6AA₁.UK

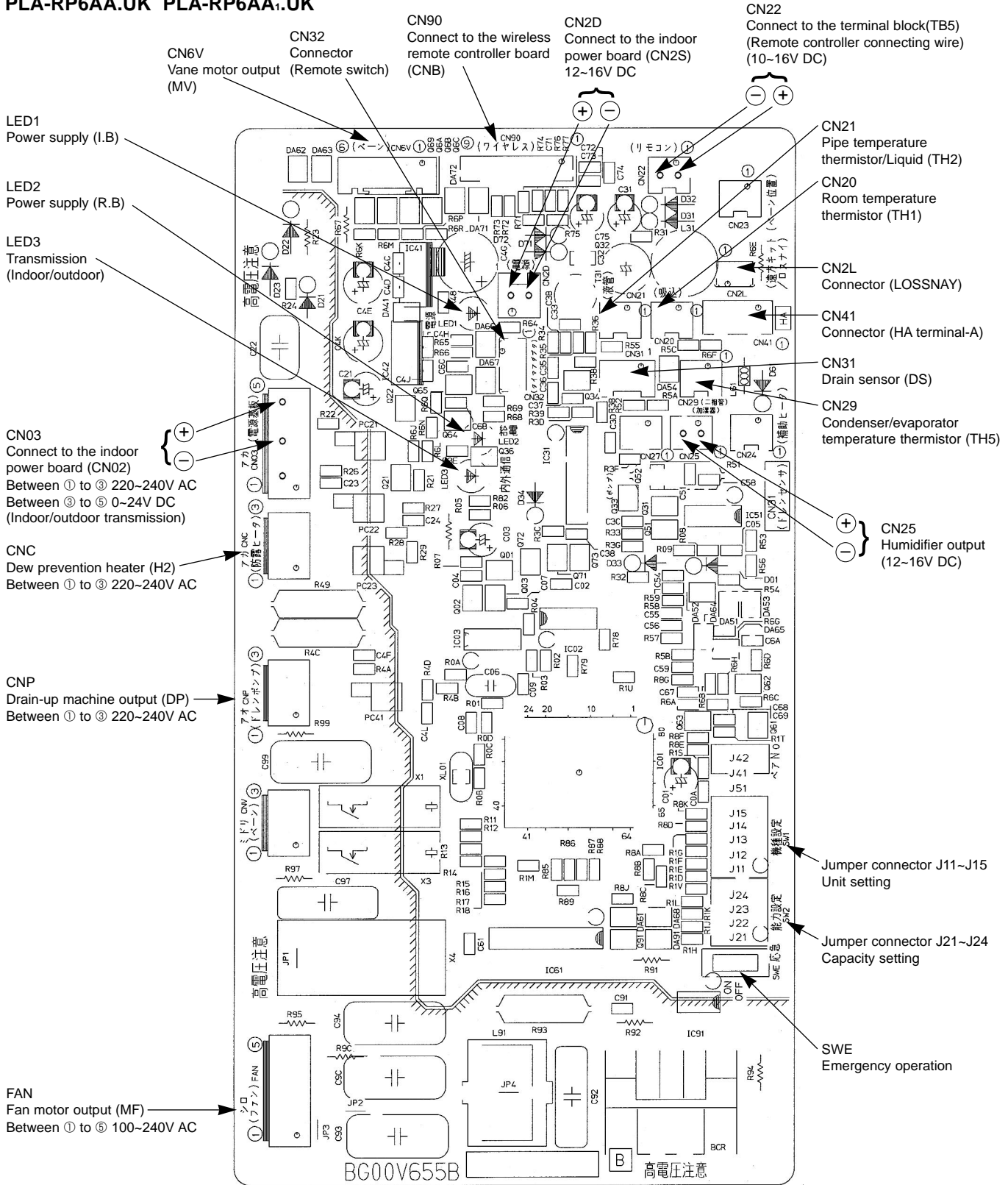

10-7. FUNCTIONS OF JUMPER WIRE

Each function is controlled by the jumper wire on control p.c. board. For service parts, J11- J15 and J21-J24, DIP switches (SW1 and SW2) are equipped with jumper wire.

(Marks in the table below) Jumper wire (○ : Short × : Open)
DIP switch (○ : ON × : OFF)

Jumper wire	Functions	Open/short of jumper wire	Remarks																																													
J11~J15 (SW1)	Model settings	<p>Models : PLA-RP1.6~6</p> <table border="1"> <thead> <tr> <th></th> <th>J11</th> <th>J12</th> <th>J13</th> <th>J14</th> <th>J15</th> </tr> </thead> <tbody> <tr> <td>Heater-less</td> <td>○</td> <td>○</td> <td>○</td> <td>○</td> <td>×</td> </tr> </tbody> </table>		J11	J12	J13	J14	J15	Heater-less	○	○	○	○	×																																		
	J11	J12	J13	J14	J15																																											
Heater-less	○	○	○	○	×																																											
J21~J24 (SW2)	Capacity settings	<table border="1"> <thead> <tr> <th>Models</th> <th>J21</th> <th>J22</th> <th>J23</th> <th>J24</th> </tr> </thead> <tbody> <tr> <td>RP1.6AA</td> <td>○</td> <td>○</td> <td>×</td> <td>×</td> </tr> <tr> <td>RP2AA</td> <td>○</td> <td>×</td> <td>○</td> <td>×</td> </tr> <tr> <td>RP2.5AA</td> <td>○</td> <td>○</td> <td>○</td> <td>×</td> </tr> <tr> <td>RP3AA,AA₁</td> <td>○</td> <td>×</td> <td>×</td> <td>○</td> </tr> <tr> <td>RP4AA,AA₁</td> <td>×</td> <td>×</td> <td>○</td> <td>○</td> </tr> <tr> <td>RP5AA</td> <td>×</td> <td>○</td> <td>○</td> <td>○</td> </tr> <tr> <td>RP5AA₁</td> <td>○</td> <td>○</td> <td>○</td> <td>○</td> </tr> <tr> <td>RP6AA,AA₁</td> <td>○</td> <td>○</td> <td>○</td> <td>○</td> </tr> </tbody> </table>	Models	J21	J22	J23	J24	RP1.6AA	○	○	×	×	RP2AA	○	×	○	×	RP2.5AA	○	○	○	×	RP3AA,AA ₁	○	×	×	○	RP4AA,AA ₁	×	×	○	○	RP5AA	×	○	○	○	RP5AA ₁	○	○	○	○	RP6AA,AA ₁	○	○	○	○	
Models	J21	J22	J23	J24																																												
RP1.6AA	○	○	×	×																																												
RP2AA	○	×	○	×																																												
RP2.5AA	○	○	○	×																																												
RP3AA,AA ₁	○	×	×	○																																												
RP4AA,AA ₁	×	×	○	○																																												
RP5AA	×	○	○	○																																												
RP5AA ₁	○	○	○	○																																												
RP6AA,AA ₁	○	○	○	○																																												
J41 J42	Pair number setting with wireless remote controller	<table border="1"> <thead> <tr> <th rowspan="2">Wireless remote controller setting</th> <th colspan="2">Control PCB setting</th> </tr> <tr> <th>J41</th> <th>J42</th> </tr> </thead> <tbody> <tr> <td>0</td> <td>○</td> <td>○</td> </tr> <tr> <td>1</td> <td>×</td> <td>○</td> </tr> <tr> <td>2</td> <td>○</td> <td>×</td> </tr> <tr> <td>3 ~ 9</td> <td>×</td> <td>×</td> </tr> </tbody> </table>	Wireless remote controller setting	Control PCB setting		J41	J42	0	○	○	1	×	○	2	○	×	3 ~ 9	×	×	<p><Settings at time of factory shipment> Wireless remote controller: 0 Control PCB: ○ (for both J41 and J42) Four pair number settings are supported. The pair number settings of the wireless remote controller and indoor control PCB (J41/J42) are given in the table on the left. ('×' in the table indicates the jumper line is disconnected.)</p>																												
Wireless remote controller setting	Control PCB setting																																															
	J41	J42																																														
0	○	○																																														
1	×	○																																														
2	○	×																																														
3 ~ 9	×	×																																														

PLA-RP1.6AA.UK PLA-RP2AA.UK PLA-RP2.5AA.UK

PLA-RP3AA.UK PLA-RP4AA.UK PLA-RP5AA.UK PLA-RP6AA.UK

PLA-RP3AA₁.UK PLA-RP4AA₁.UK PLA-RP5AA₁.UK PLA-RP6AA₁.UK

Be careful on removing heavy parts.

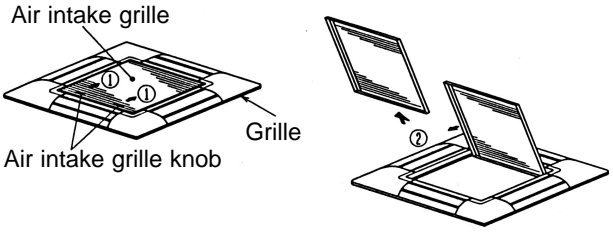
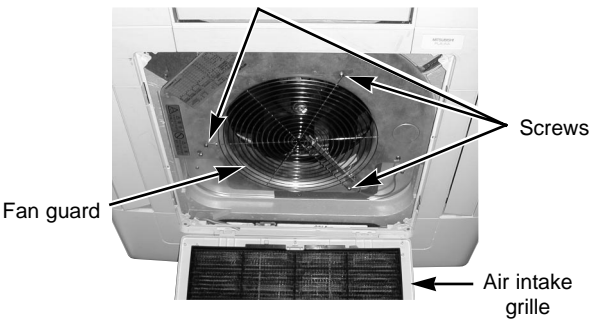
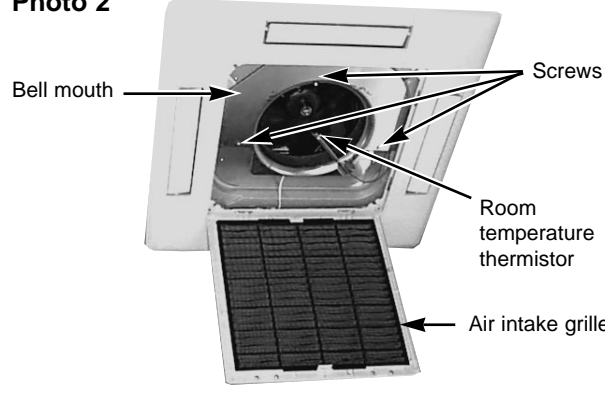
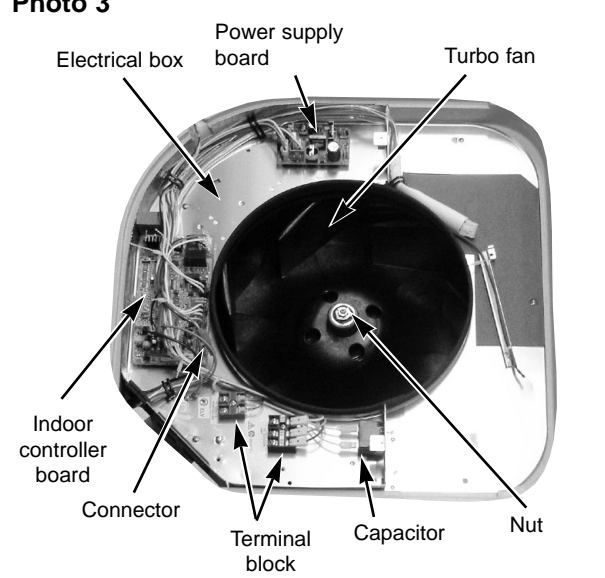
OPERATING PROCEDURE	PHOTOS & ILLUSTRATIONS
<p>1. Removing the air intake grille</p> <p>(1) Slide the knob of air intake grille toward the arrow ① to open the air intake grille.</p> <p>(2) Remove drop prevention hook from the panel.</p> <p>(3) Slide the shaft in the hinge to the direction of the arrow ② and remove the air intake grille.</p>	<p>Figure 1</p>  <p>Air intake grille Air intake grille knob Grille</p>
<p>2. Removing the fan guard</p> <p>(1) Open the air intake grille.</p> <p>(2) Remove the 3 screws of fan guard.</p>	<p>Photo 1</p>  <p>Fan guard Screws Air intake grille</p>
<p>3. Removing the room temperature thermistor</p> <p>(1) Remove the fan guard. (See photo 1)</p> <p>(2) Remove the screw in the room temperature thermistor holder to remove the holder and the room temperature thermistor.</p> <p>(3) Remove the 1 screw from the bell mouth, and unscrew the other 2 screws (fix to the oval hole which has a different diameter) to remove the bell mouth.</p> <p>(4) Remove the holder claw, and remove the room temperature thermistor and holder.</p> <p>(5) Disconnect the connector (red) from the indoor control board.</p>	<p>Photo 2</p>  <p>Bell mouth Screws Room temperature thermistor Air intake grille</p>
<p>4. Removing the electrical box</p> <p>(1) Remove the fan guard. (See photo 1)</p> <p>(2) Remove the lead wire of the vane motor from the clamp, and disconnect the white connector (10P).</p> <p>(3) Remove the room temperature thermistor with the holder.</p> <p>(4) Remove the bell mouth. (See photo 2)</p> <p>(5) Disconnect the relay connector in the electrical box.</p> <p>Red (3P) for fan motor power supply White (2P) for pipe temperature detecting thermistor Black (2P) for condenser/evaporator pipe temperature detecting thermistor Blue (2P) for drain pump White (3P) for drain sensor</p> <p>(6) Remove the 3 screws of the electrical box and loosen the other 2 screws to remove the box.</p> <p><Electrical parts in the electrical box></p> <p>Indoor controller board Power supply board Terminal block Capacitor</p>	<p>Photo 3</p>  <p>Electrical box Power supply board Turbo fan Indoor controller board Connector Terminal block Capacitor Nut</p>

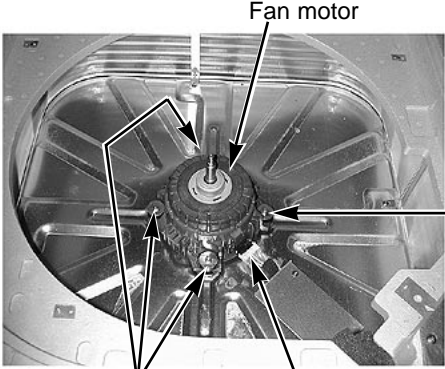
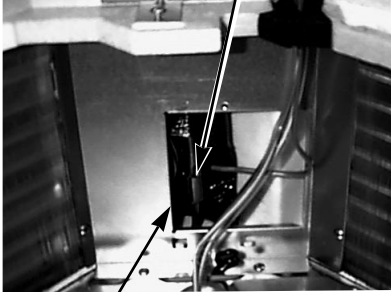
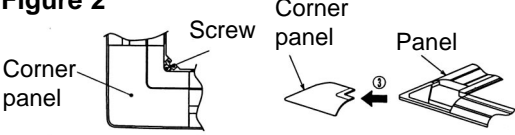
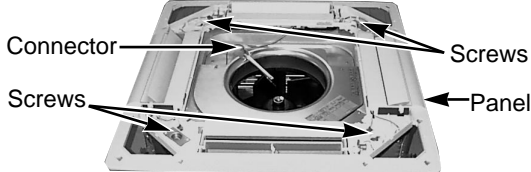
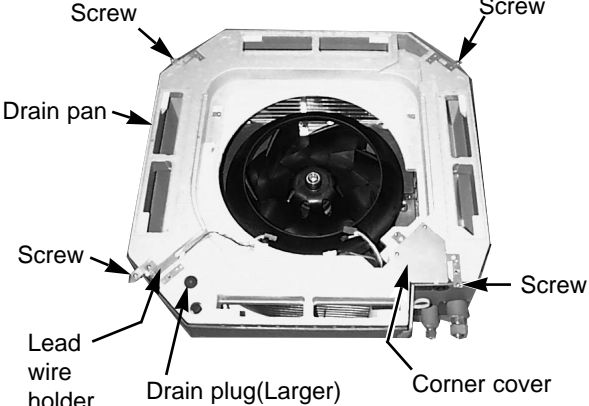

OPERATING PROCEDURE	PHOTOS & ILLUSTRATIONS
<p>5. Removing the fan motor</p> <ol style="list-style-type: none">(1) Remove the fan guard.(See photo 1)(2) Remove the bell mouth.(See photo 2)(3) Remove the electrical box.(See photo 3)(4) Remove the turbo fan nut.(5) Pull out the turbo fan.(6) Disconnect the connector of the fan motor lead wire.(7) Remove the 4 nuts of the fan motor.	<p>Photo 4</p>  <p>Fan motor</p> <p>Nut</p> <p>Nut</p> <p>Connector</p>
<p>6. Removing the pipe temperature thermistor and condenser evaporator temperature thermistor</p> <ol style="list-style-type: none">(1) Remove the fan guard.(See photo 1)(2) Remove the bell mouth.(See photo 2)(3) Remove the electrical box.(See photo 3)(4) Remove the turbo fan.(5) Remove the screw of the service panel.(6) Remove the service panel.(7) Remove the pipe temperature thermistor which are inserted into the holder installed to the thin copper pipe.(8) Disconnect the 2-pin white connector.	<p>Photo 5</p>  <p>Pipe temperature thermistor</p> <p>Service access</p>
<p>7. Removing the panel</p> <ol style="list-style-type: none">(1) Remove the air intake grille.(See figure 1) <p>Corner panel (See figure 2)</p> <ol style="list-style-type: none">(1) Remove the corner screw.(2) Slide the corner panel to the direction of the arrow ③, and remove the corner panel. <p>Panel (See photo 6)</p> <ol style="list-style-type: none">(1) Disconnect the connector that connects with the unit.(2) Remove the 2 screws from the panel and loosen another 2 screws, which fix to the oval holes, have different diameters.(3) Rotate the panel a little to remove the panel.	<p>Figure 2</p>  <p>Screw</p> <p>Corner panel</p> <p>Panel</p> <p>Photo 6</p>  <p>Connector</p> <p>Screws</p> <p>Screws</p> <p>Panel</p>
<p>8. Removing the drain pan</p> <ol style="list-style-type: none">(1) Remove the panel. (See photo 6)(2) Remove the drain plug (Larger one), drain the remaining water in the drain pan.(3) Remove the corner cover. (2 screws)(4) Remove the bell mouth. (See photo 2)(5) Remove the electrical box. (See photo 3)(6) Remove the lead wire holder. (1 screw)(7) Remove the 4 screws and pull out the drain pan. <p>* Pull out the left and right of the pan gradually. Be careful not to crack or damage the pan.</p>	<p>Photo 7</p>  <p>Screw</p> <p>Screw</p> <p>Drain pan</p> <p>Screw</p> <p>Screw</p> <p>Lead wire holder</p> <p>Drain plug(Larger)</p> <p>Corner cover</p>

OPERATING PROCEDURE

PHOTOS & ILLUSTRATIONS

9. Removing the drain pump and drain sensor

- (1) Remove the panel. (See photo 6)
- (2) Remove the fan guard. (See photo 1)
- (3) Remove the bell mouth. (See photo 2)
- (4) Remove the electrical box. (See photo 3)
- (5) Remove the drain pan. (See photo 7)
- (6) Remove the 3 screws of the drain pump.
- (7) Cut the drain hose band, pull out the drain hose from the drain pump.
- (8) Pull out the drain pump.
- (9) Remove the drain sensor and the holder.

Photo 8

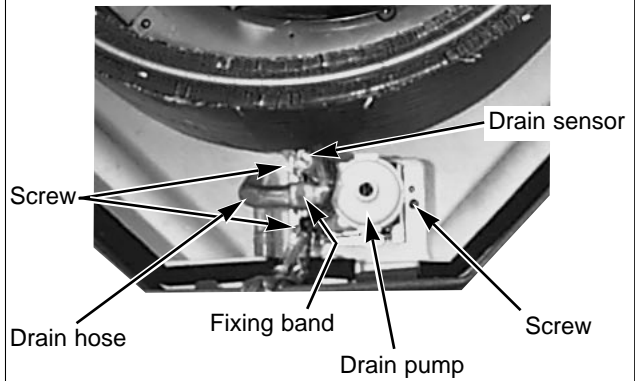

10. Removing the heat exchanger

- (1) Remove the panel. (See photo 6)
- (2) Remove the fan guard. (See photo 1)
- (3) Remove the bell mouth. (See photo 2)
- (4) Remove the electrical box. (See photo 3)
- (5) Remove the drain pan. (See photo 7)
- (6) Remove the turbo fan. (See photo 4)
- (7) Remove the 3 screws of the piping cover, and pull out piping cover.
- (8) Remove the 4 screws of the outer wall cover, and pull out the outer wall cover.
- (9) Remove the screw of the coil support.
- (10) Remove the 2 screws of the coil.
- (11) Pull out the heat exchanger.

Photo 9

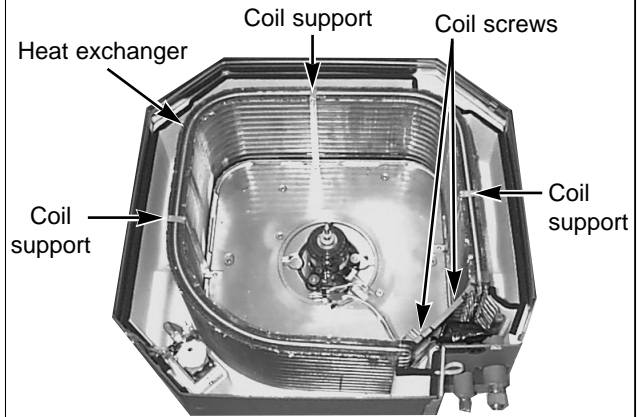
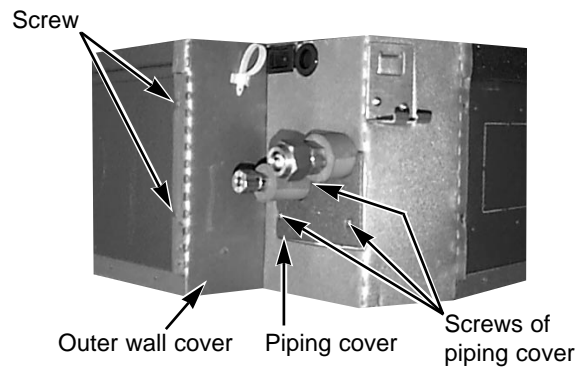

Photo 10



PANEL PARTS

PLA-RP1.6AA.UK

PLA-RP2AA.UK

PLA-RP2.5AA.UK

PLA-RP3AA.UK PLA-RP3AA.1.UK

PLA-RP4AA.UK PLA-RP4AA.1.UK

PLA-RP5AA.UK PLA-RP5AA.1.UK

PLA-RP6AA.UK PLA-RP6AA.1.UK

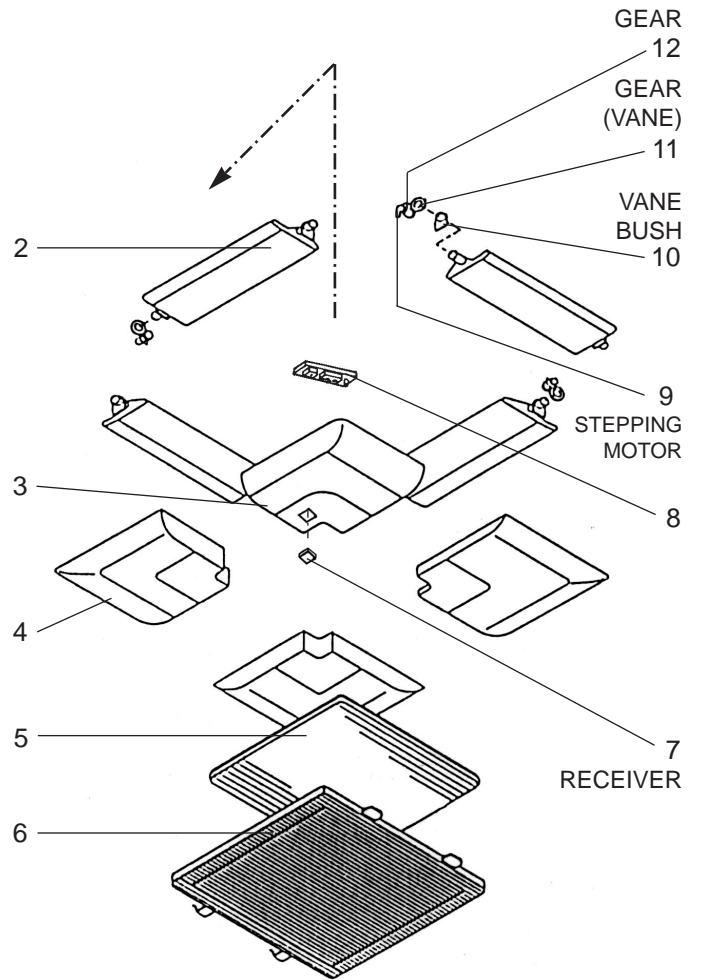
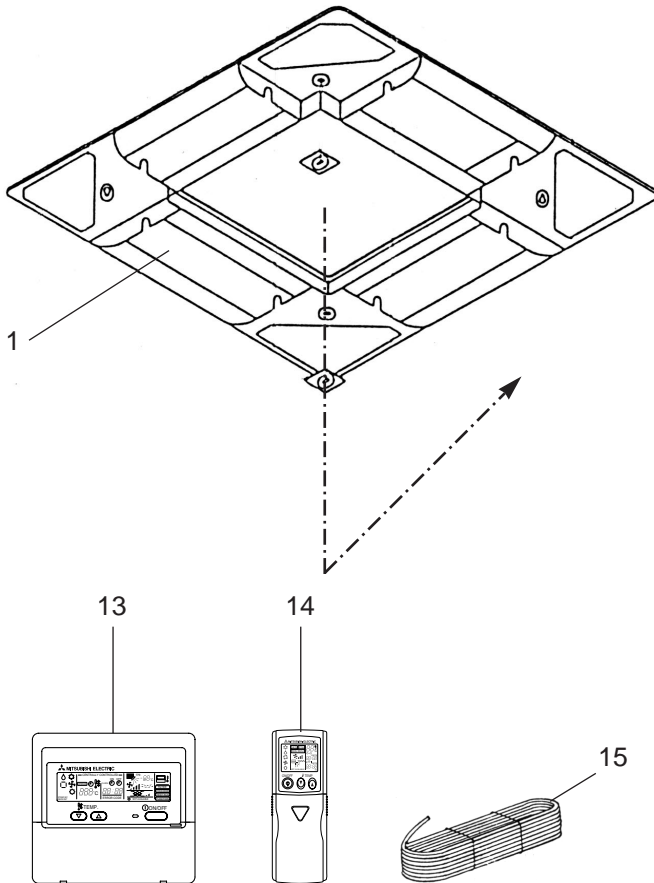

No.	Parts No.	Parts Name	Specifi- cation	Q'ty / set		Remarks (Drawing No.)	Wiring Diagram Symbol	Recom- mended Q'ty	Price	
				PLA-RP1,6,2,2,5,3,4,5,6AA.UK PLA-RP3,4,5,6AA.1.UK	WIRED				WIRELESS	Unit
1	S70 E10 003	AIR OUTLET GRILLE		1	1					
2	S70 E01 002	VANE ASSY		4	4					
3	S70 E01 638	CORNER PANEL		1	2					
4	S70 E00 638	CORNER PANEL		3	2					
5	S70 E00 500	L.L FILTER-A		1	1					
6	S70 E00 691	GRILLE ASSY		1	1					
7	S70 24K 658	RECEIVER			1		RU			
8	S70 E00 317	WIRELESS ADAPTER			1		W.B			
9	S70 E00 223	STEPPING MOTOR		4	4		MV			
10	S70 E00 063	VANE BUSH		8	8					
11	S70 E00 040	GEAR (VANE)		4	4					
12	S70 E01 040	GEAR		4	4					
13	S70 E13 713	REMOTE CONTROLLER ASSY	PAR-20MAA-E	1			R.B			
14	S70 E15 714	WIRELESS REMOTE CONTROLLER ASSY	PAR-SL97A-E		1					
15	S70 58A 246	CORD		1	1					

FUNCTIONAL PARTS

PLA-RP1.6AA.UK

PLA-RP2AA.UK

PLA-RP2.5AA.UK

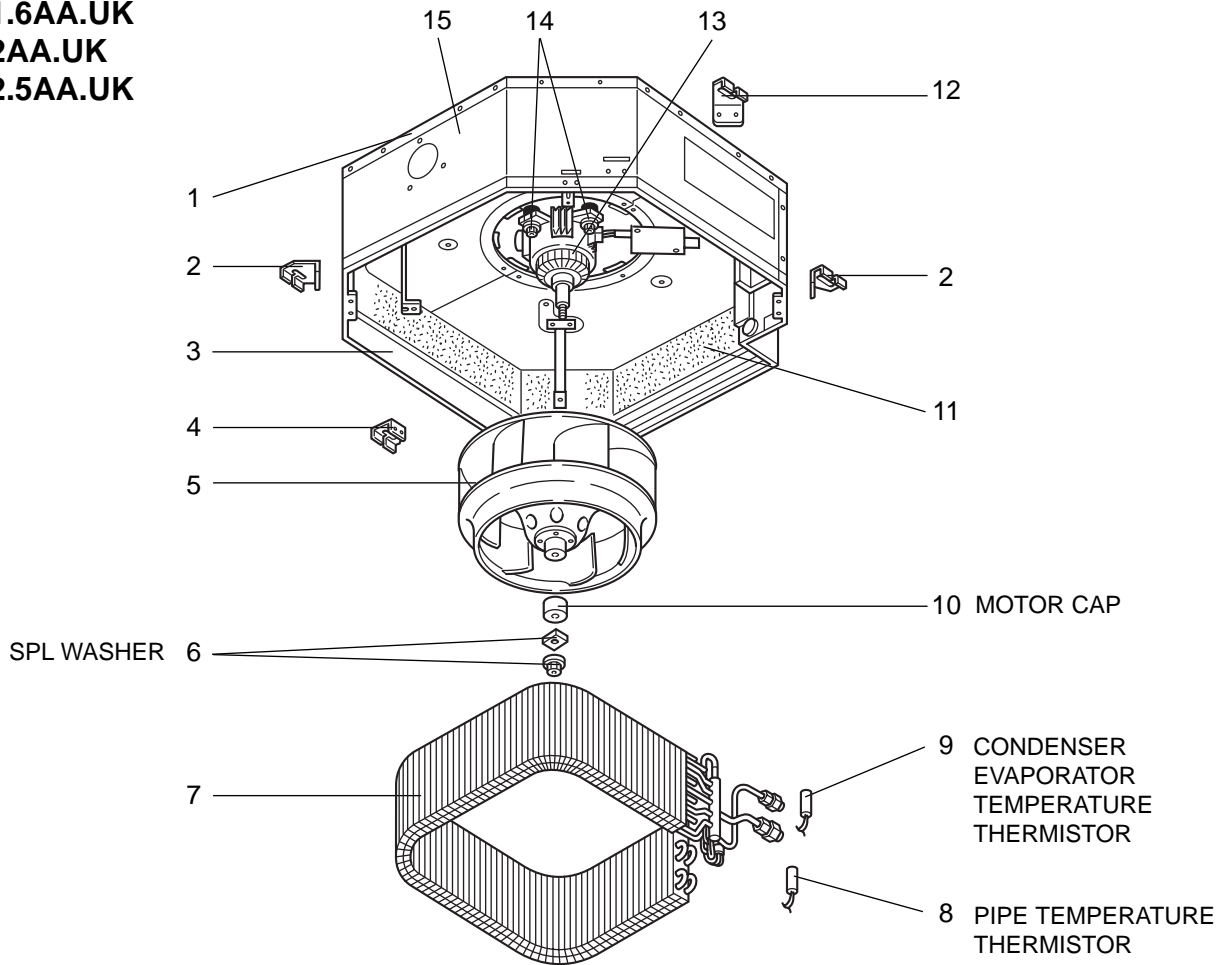

No.	Parts No.	Parts Name	Specifi- cation	Q'ty / set		Remarks (Drawing No.)	Wiring Diagram Symbol	Recom- mended Q'ty	Price	
				PLA-RP1.6AA.UK PLA-RP2AA.UK	PLA-RP2.5AA.UK				Unit	Amount
1	S70 003 687	BASE		1	1					
2	S70 E01 130	LEG		2	2					
3	S70 005 688	DRUM 1 ASSY		1	1					
4	S70 E00 130	LEG		1	1					
5	S70 E00 114	TURBO FAN		1	1					
6	S70 08K 097	SPL WASHER / NUT		1	1					
7	S70 R21 480	HEAT EXCHANGER		1						
	S70 E40 480	HEAT EXCHANGER			1					
8	S70 17J 202	PIPE TEMPERATURE THERMISTOR		1	1		TH2			
9	S70 E20 202	CONDENSER EVAPORATOR TEMPERATURE THERMISTOR		1	1		TH5			
10	S70 E50 129	MOTOR CAP		1	1					
11	S70 E00 659	INNER COVER		1	1					
12	S70 E02 130	LEG		1	1					
13	S70 E06 762	FAN MOTOR	D17B6P70MS	1	1		MF			
14	S70 A41 105	MOTOR MOUNT		4	4					
15	S70 006 688	DRUM 2 ASSY		1	1					

FUNCTIONAL PARTS

PLA-RP3AA.UK PLA-RP3AA₁.UK
 PLA-RP4AA.UK PLA-RP4AA₁.UK

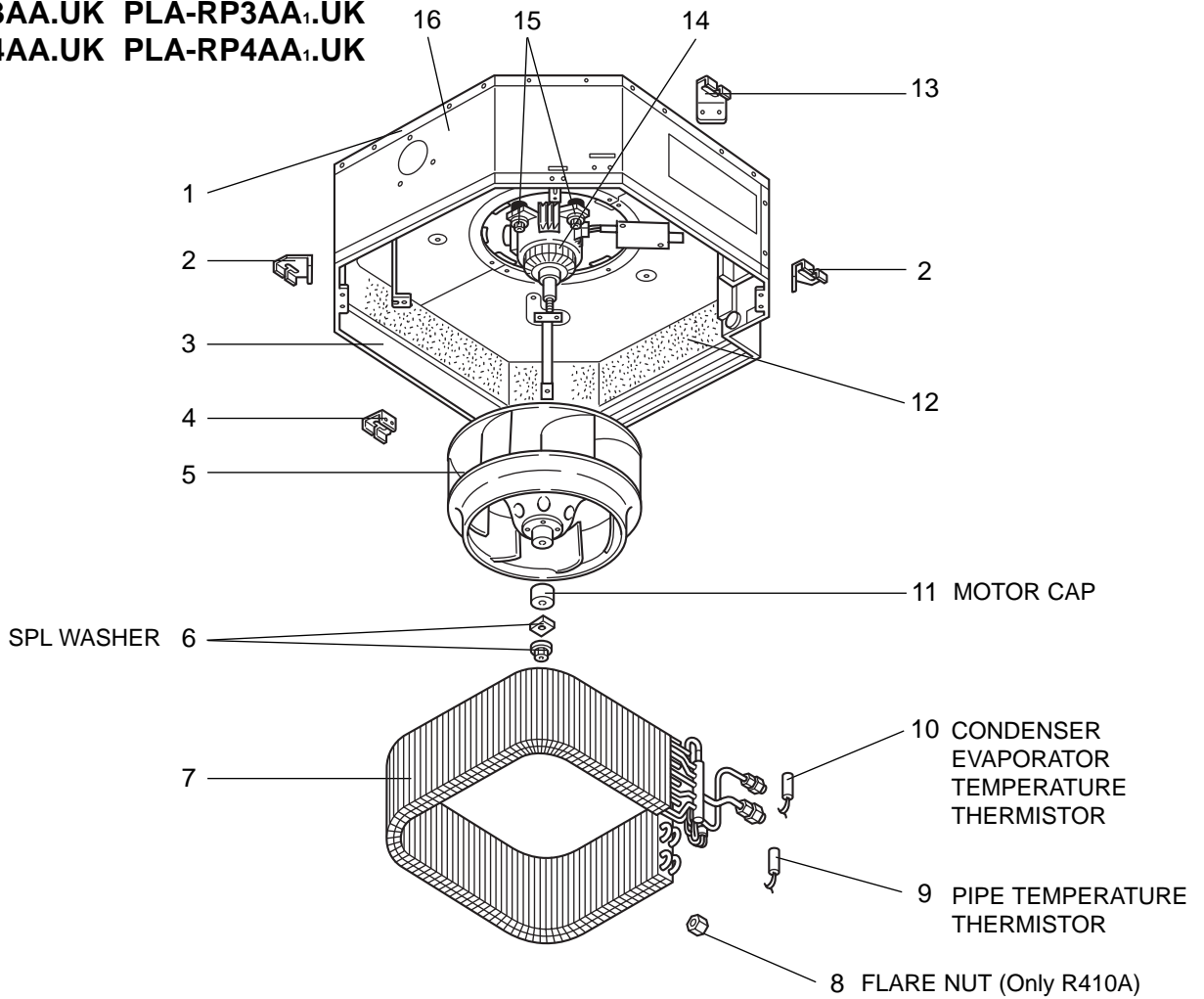

No.	Parts No.	Parts Name	Specifi- cation	Q'ty / set		Remarks (Drawing No.)	Wiring Diagram Symbol	Recom- mended Q'ty	Price	
				PLA-RP3AA.UK PLA-RP3AA ₁ .UK	PLA-RP4AA.UK PLA-RP4AA ₁ .UK				Unit	Amount
1	S70 003 687	BASE		1	1					
2	S70 E01 130	LEG		2	2					
3	S70 005 688	DRUM 1 ASSY		1						
	S70 007 688	DRUM 1 ASSY			1					
4	S70 E00 130	LEG		1	1					
5	S70 E00 114	TURBO FAN		1						
	S70 E01 114	TURBO FAN			1					
6	S70 08K 097	SPL WASHER / NUT		1	1					
7	S70 E40 480	HEAT EXCHANGER		1						
	S70 E41 480	HEAT EXCHANGER			1					
8	S70 E50 097	FLARE NUT	I.D. 5/8 O.D. 3/4		1					
9	S70 17J 202	PIPE TEMPERATURE THERMISTOR		1	1		TH2			
10	S70 E20 202	CONDENSER EVAPORATOR TEMPERATURE THERMISTOR		1	1		TH5			
11	S70 E50 129	MOTOR CAP		1	1					
12	S70 E00 659	INNER COVER		1						
	S70 E02 659	INNER COVER			1					
13	S70 E02 130	LEG		1	1					
14	S70 E06 762	FAN MOTOR	D17B6P70MS	1			MF			
	S70 E07 762	FAN MOTOR	D176P120MS		1		MF			
15	S70 A41 105	MOTOR MOUNT		4	4					
16	S70 006 688	DRUM 2 ASSY		1						
	S70 008 688	DRUM 2 ASSY			1					

FUNCTIONAL PARTS

PLA-RP5AA.UK PLA-RP5AA1.UK
 PLA-RP6AA.UK PLA-RP6AA1.UK

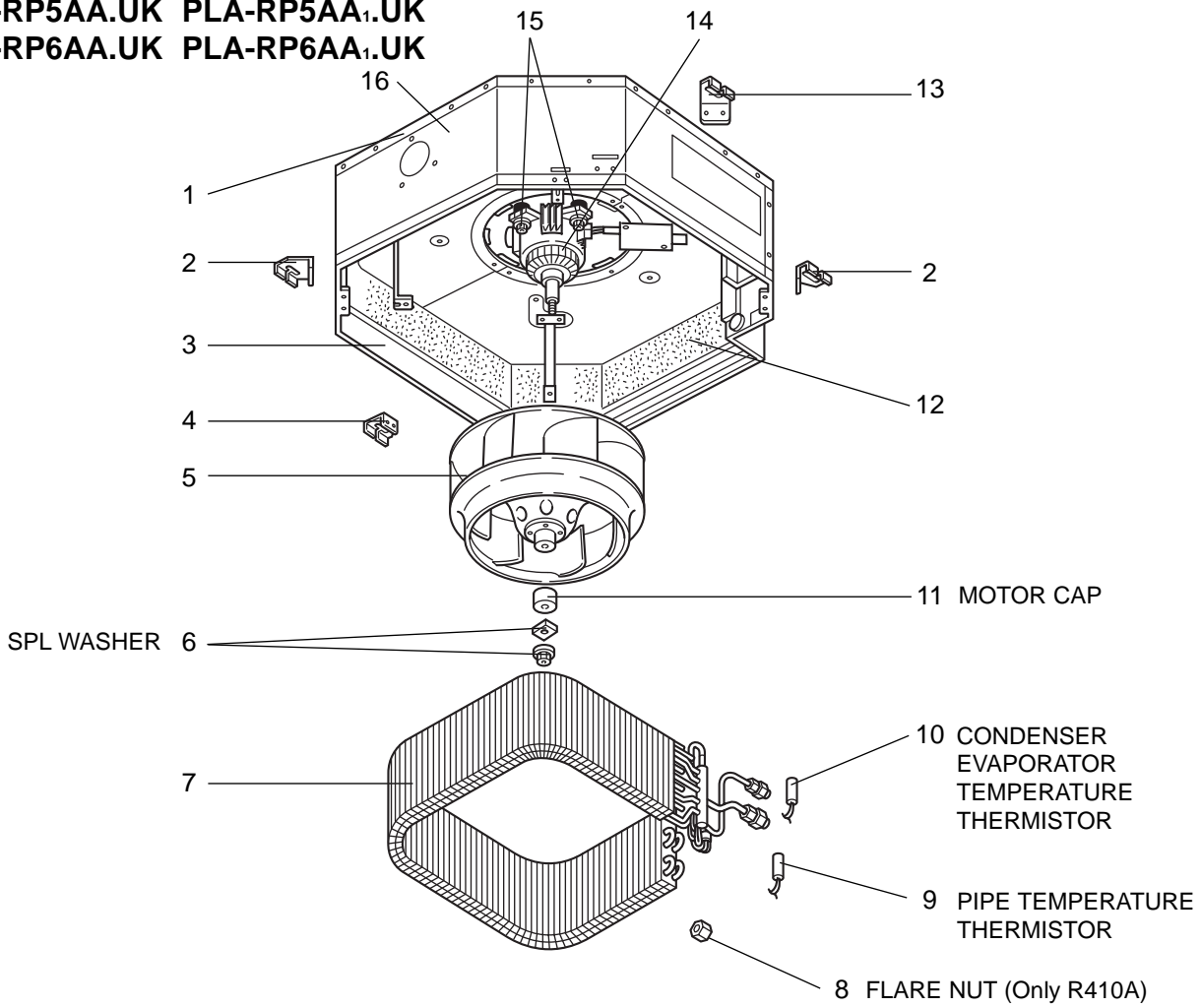

No.	Parts No.	Parts Name	Specifi- cation	Q'ty / set		Remarks (Drawing No.)	Wiring Diagram Symbol	Recom- mended Q'ty	Price	
				PLA-RP5AA.UK PLA-RP5AA1.UK	PLA-RP6AA.UK PLA-RP6AA1.UK				Unit	Amount
1	S70 003 687	BASE		1	1					
2	S70 E01 130	LEG		2	2					
3	S70 007 688	DRUM 1 ASSY		1	1					
4	S70 E00 130	LEG		1	1					
5	S70 E01 114	TURBO FAN		1	1					
6	S70 08K 097	SPL WASHER		1	1					
7	S70 E42 480	HEAT EXCHANGER		1	1					
8	S70 E50 097	FLARE NUT	I.D. 5/8 O.D. 3/4	1	1					
9	S70 17J 202	PIPE TEMPERATURE THERMISTOR		1	1		TH2			
10	S70 E20 202	CONDENSER EVAPORATOR TEMPERATURE THERMISTOR		1	1		TH5			
11	S70 E50 129	MOTOR CAP		1	1					
12	S70 E02 659	INNER COVER		1	1					
13	S70 E02 130	LEG		1	1					
14	S70 E07 762	FAN MOTOR		1	1		MF			
15	S70 A41 105	MOTOR MOUNT	D176P120MS	4	4					
16	S70 008 688	DRUM 2 ASSY		1	1					

FUNCTIONAL PARTS
PLA-RP1.6AA.UK
PLA-RP2AA.UK
PLA-RP2.5AA.UK

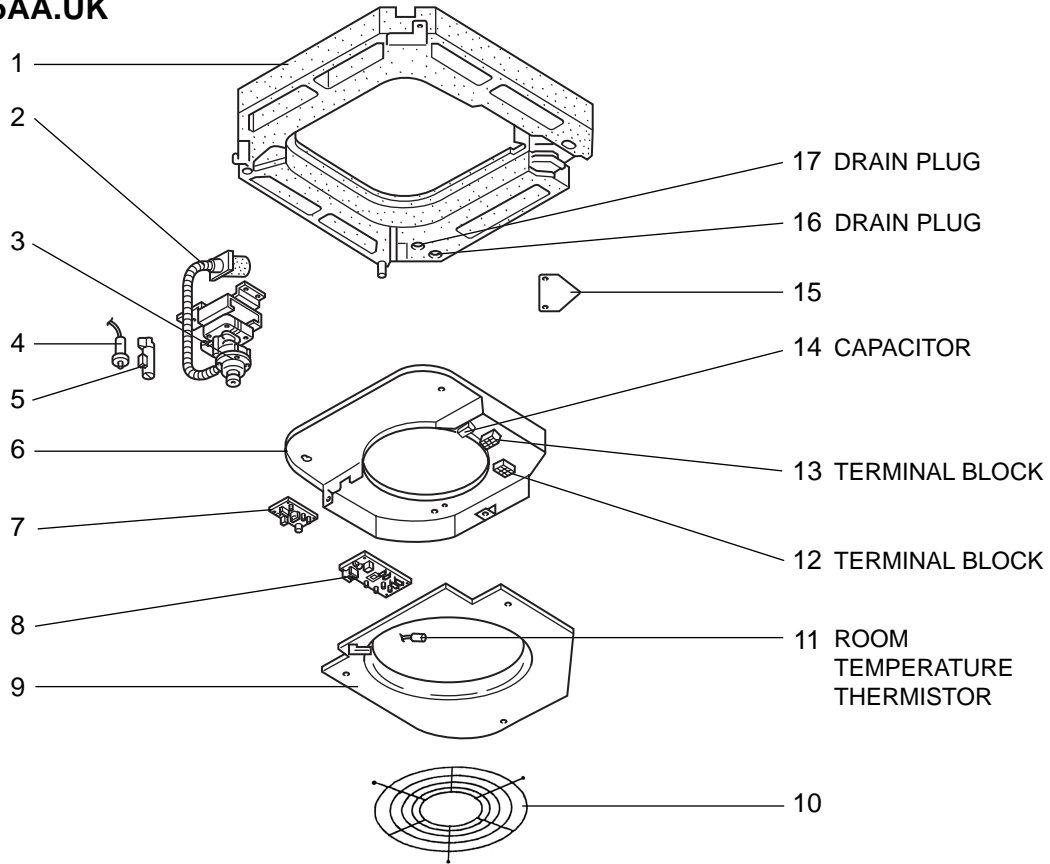

Part numbers that is circled is not shown in the figure.

No.	Parts No.	Parts Name	Specification	Q'ty / set	Remarks (Drawing No.)	Wiring Diagram Symbol	Recom- mended Q'ty	Price	
				PLA-RP1.6AA.UK PLA-RP2AA.UK PLA-RP2.5AA.UK				Unit	Amount
1	S70 E02 529	DRAIN PAN		1					
2	S70 29H 523	DRAIN SOCKET		1					
3	S70 E02 355	DRAIN PUMP		1		DP			
4	S70 E00 266	DRAIN SENSOR		1		DS			
5	S70 31K 241	DRAIN SENSOR HOLDER		1					
6	S70 E20 501	ELECTRICAL CONTROL BOX		1					
7	S70 E20 313	POWER BOARD		1		P.B			
8	S70 E45 310	INDOOR CONTROLLER BOARD		1		I.B			
9	S70 003 503	CONTROL COVER ASSY		1					
10	S70 E10 675	FAN GUARD		1					
11	S70 E00 202	ROOM TEMPERATURE THERMISTOR		1		TH1			
12	S70 512 716	TERMINAL BLOCK	2P (1, 2)	1		TB5			
13	S70 E01 716	TERMINAL BLOCK	3P (S1, S2, S3)	1		TB4			
14	S70 576 255	CAPACITOR	3 μ F 440V	1		C			
15	S70 001 663	CORNER COVER		1					
16	S70 A48 524	DRAIN PLUG		1					
17	S70 A41 524	DRAIN PLUG		1					
18	S70 A41 523	DRAIN HOSE ASSY		1					

FUNCTIONAL PARTS

PLA-RP3AA.UK PLA-RP3AA₁.UK

PLA-RP4AA.UK PLA-RP4AA₁.UK

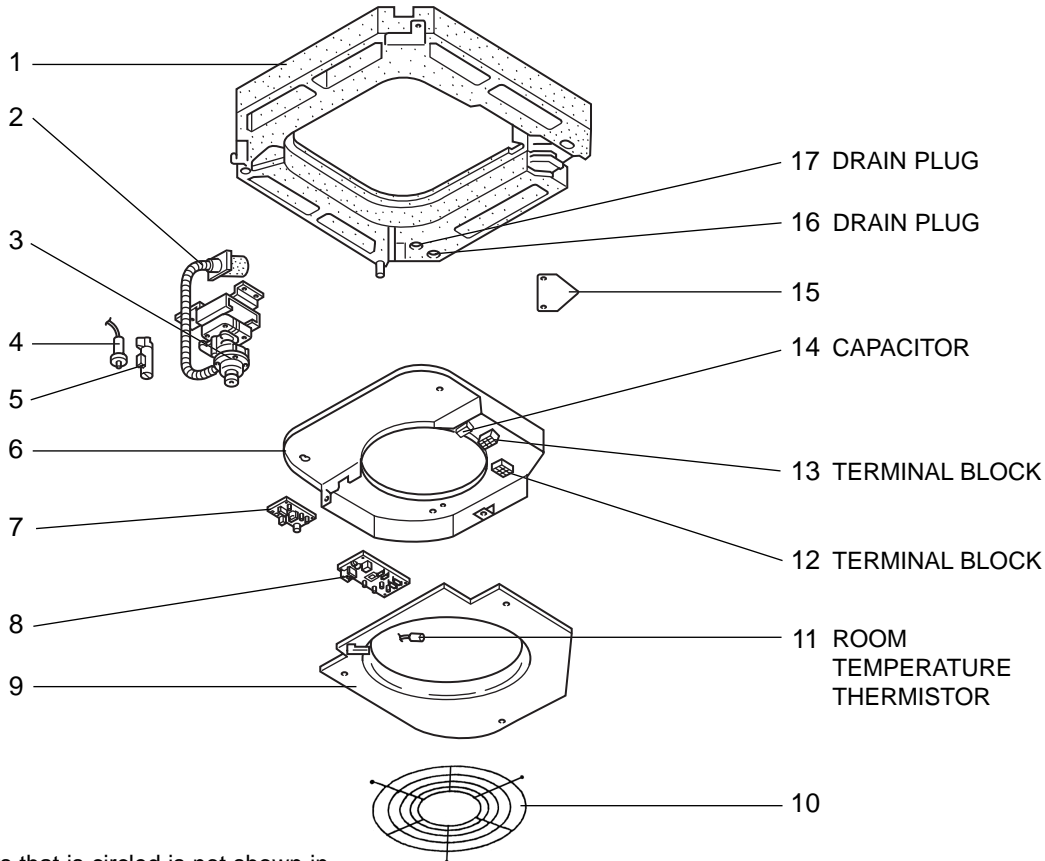

Part numbers that is circled is not shown in

No.	Parts No.	Parts Name	Specifi- cation	Q'ty / set		Remarks (Drawing No.)	Wiring Diagram Symbol	Recom- mended Q'ty	Price	
				PLA-RP3AA.UK PLA-RP3AA ₁ .UK	PLA-RP4AA.UK PLA-RP4AA ₁ .UK				Unit	Amount
1	S70 E02 529	DRAIN PAN		1						
	S70 E00 529	DRAIN PAN			1					
2	S70 29H 523	DRAIN SOCKET		1	1					
3	S70 E02 355	DRAIN PUMP		1	1		DP			
4	S70 E00 266	DRAIN SENSOR		1	1		DS			
5	S70 31K 241	DRAIN SENSOR HOLDER		1	1					
6	S70 E20 501	ELECTRICAL CONTROL BOX		1	1					
7	S70 E20 313	POWER BOARD		1	1		P.B			
8	S70 R03 310	INDOOR CONTROLLER BOARD		1	1		I.B			
9	S70 003 503	CONTROL COVER ASSY		1	1					
10	S70 E10 675	FAN GUARD		1	1					
11	S70 E00 202	ROOM TEMPERATURE THERMISTOR		1	1		TH1			
12	S70 512 716	TERMINAL BLOCK	2P (1, 2)	1	1		TB5			
13	S70 E01 716	TERMINAL BLOCK	3P (S1, S2, S3)	1	1		TB4			
14	S70 17T 255	CAPACITOR	3.5 μ F 440V	1			C			
	S70 E02 255	CAPACITOR	7.0 μ F 440V		1		C			
15	S70 001 663	CORNER COVER		1	1					
16	S70 A48 524	DRAIN PLUG		1	1					
17	S70 A41 524	DRAIN PLUG		1	1					
18	S70 A41 523	DRAIN HOSE ASSY		1	1					

FUNCTIONAL PARTS
PLA-RP5AA.UK PLA-RP5AA.i.UK
PLA-RP6AA.UK PLA-RP6AA.i.UK

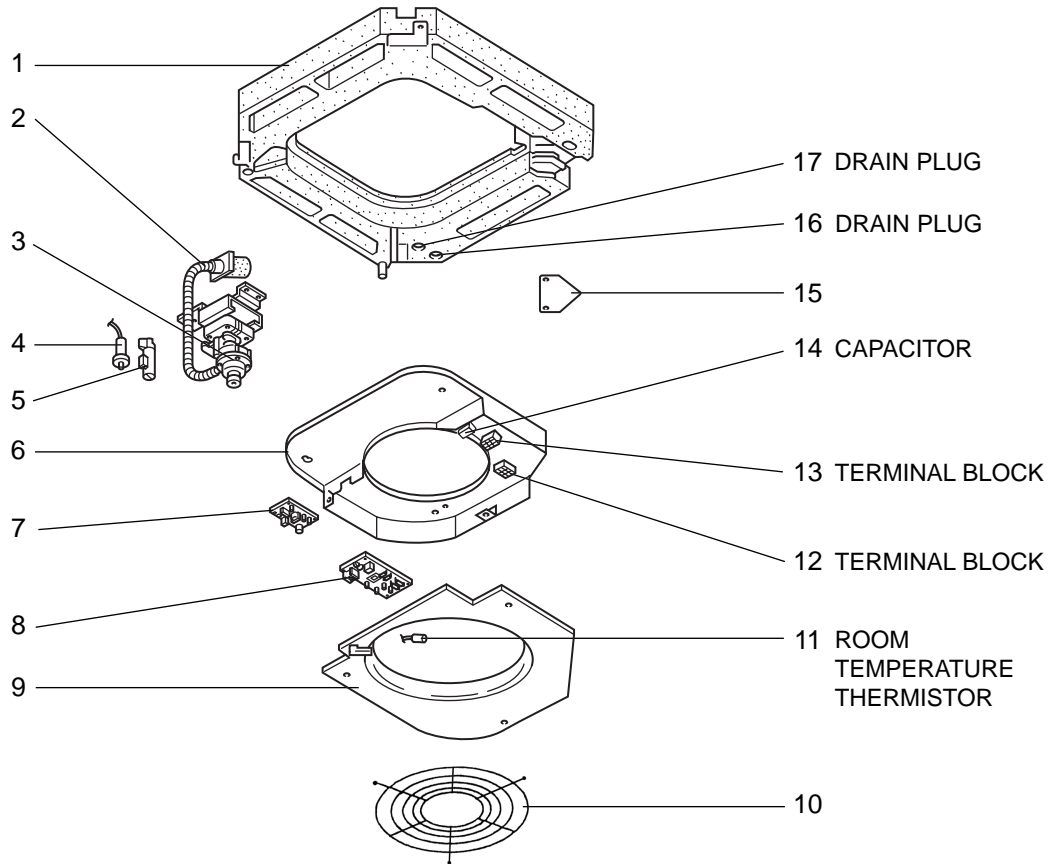

Part numbers that is circled is not shown in the figure.

No.	Parts No.	Parts Name	Specifi- cation	Q'ty / set		Remarks (Drawing No.)	Wiring Diagram Symbol	Recom- mended Q'ty	Price	
				PLA-RP5AA.UK PLA-RP5AA.i.UK	PLA-RP6AA.UK PLA-RP6AA.i.UK				Unit	Amount
1	S70 E01 529	DRAIN PAN		1	1					
2	S70 29H 523	DRAIN SOCKET		1	1					
3	S70 E02 355	DRAIN PUMP		1	1		DP			
4	S70 E00 266	DRAIN SENSOR		1	1		DS			
5	S70 31K 241	DRAIN SENSOR HOLDER		1	1					
6	S70 E20 501	ELECTRICAL CONTROL BOX		1	1					
7	S70 E20 313	POWER BOARD		1	1		P.B			
8	S70 R03 310	INDOOR CONTROLLER BOARD		1	1		I.B			
9	S70 003 503	CONTROL COVER ASSY		1	1					
10	S70 E10 675	FAN GUARD		1	1					
11	S70 E00 202	ROOM TEMPERATURE THERMISTOR		1	1		TH1			
12	S70 512 716	TERMINAL BLOCK	2P (1, 2)	1	1		TB5			
13	S70 E01 716	TERMINAL BLOCK	3P (S1, S2, S3)	1	1		TB4			
14	S70 E02 255	CAPACITOR	7.0 μ F 440V	1	1		C			
15	S70 001 663	CORNER COVER		1	1					
16	S70 A48 524	DRAIN PLUG		1	1					
17	S70 A41 524	DRAIN PLUG		1	1					
18	S70 A41 523	DRAIN HOSE ASSY		1	1					

13-1. PROGRAM TIMER

Part No.

PAC-YT32PTA

13-1-1. Names and functions

<PAC-YT32PTA>

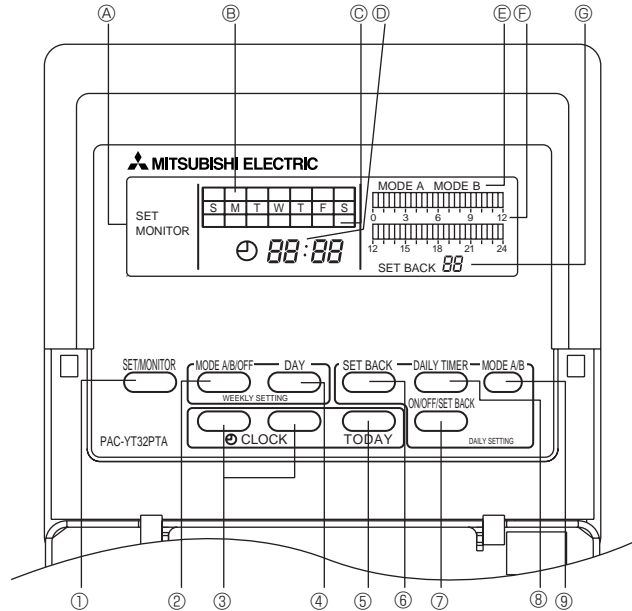

- A** SET/MONITOR DISPLAY:
When SET is displayed, clock adjustment, change of day, and daily and weekly timer settings can be performed. When MONITOR is displayed, all switches except SET/MONITOR SW are invalidated. This is normal status.
- B** WEEKLY TIMER SETTING DISPLAY:
Used to select whether the operation pattern set using the PATTERN SETTING can be applied to different days of the week.
- C** CURRENT DAY DISPLAY:
Indicates the current day.
- D** CURRENT TIME DISPLAY:
During MONITOR status, current time is displayed.
During daily timer setting, a time desired for timer setting is displayed.
- E** OPERATION MODE DISPLAY:
Indicates the operation mode.
- F** DAILY TIMER SETTING DISPLAY:
24 hours is divided into 48 blocks and each block is expressed in 30 minutes.
The block display consists of 3 patterns.
- G** SET BACK DISPLAY
Indicates the set back value.
- 1** SET/MONITOR Button
Using this switch, select "MONITOR" or "SET" Mode.
"MONITOR": Indicates the current timer setting. All switches expect MODE SELECTOR SW are invalidated then. This is the normal status.
"SET": Set to "SET" mode for clock adjustment, change of day and daily and weekly timer settings.
- 2** MODE A/B/OFF Button
Used for setting timer in day of week unit.
- 3** CLOCK ADJUSTMENT Button
Used for adjustment of the current time.
Push [▲] SW to advance the time. Each time the button is pushed the time advances by 1 minute, pushing continuously advances by 1 minute at 0.5 second intervals, and when the lower digit of the minute becomes "0" the time advances in 10 minute units.
[▼] SW is used for reversing the time. Each time the button is pushed the time reverses by 1 minute, pushing continuously reverses the time by 1 minute at 0.5 second intervals, and when the lower digit of the minute becomes "0" the time reverses in 10 minute units.
- 4** DAY SETTING Button
Used when setting the day.
- 5** WEEK DAY SETTING Button
Used for week day setting.
Pushing [▶] SW moves the week day light display in order of S → M → T → W → ... enabling to set the week day.
- 6** SET BACK SETTING Button
Used for set back setting.
Set back can be done in the range of 1, 2, 4, 6 and 8°C (2, 4, 8, 12 and 16°F).
- 7** ON/OFF/SET BACK Button
Used to specify the time setting pattern.
- 8** DAILY TIMER Button
Used for timer setting in 30 minute units.
- 9** MODE A/B Button
Used to set A Mode or B Mode when specifying the operation time.

13-2. MULTI-FUNCTIONAL CASEMENT

Part No.	PAC-SG03TM-E
Applied Service Ref.	PLA-RP1.6,2,2.5,3,4,5,6AA.UK PLA-RP3,4,5,6AA1.UK

13-3. HIGH-EFFICIENCY FILTER ELEMENT (13-2. MULTI-FUNCTIONAL CASEMENT is needed.)

Part No.	PAC-SG01KF
Applied Service Ref.	PLA-RP1.6,2,2.5,3,4,5,6AA.UK PLA-RP3,4,5,6AA1.UK

13-4. GRILLE + WIRELESS REMOTE CONTROLLER

Part No.	PLP-6AALM
Applied Service Ref.	PLA-RP1.6,2,2.5,3,4,5,6AA.UK PLA-RP3,4,5,6AA1.UK

13-5. GRILLE + WIRED REMOTE CONTROLLER

Part No.	PLP-6AAM
Applied Service Ref.	PLA-RP1.6,2,2.5,3,4,5,6AA.UK PLA-RP3,4,5,6AA1.UK

13-6. REMOTE SENSOR

Part No.	PAC-SE41TS-E
Applied Service Ref.	PLA-RP1.6,2,2.5,3,4,5,6AA.UK PLA-RP3,4,5,6AA1.UK

13-7. REMOTE OPERATION ADAPTER

Part No.	PAC-SF40RM-E
Applied Service Ref.	PLA-RP1.6,2,2.5,3,4,5,6AA.UK PLA-RP3,4,5,6AA1.UK

13-8. REMOTE ON/OFF ADAPTER

Part No.	PAC-SE55RA-E
Applied Service Ref.	PLA-RP1.6,2,2.5,3,4,5,6AA.UK PLA-RP3,4,5,6AA1.UK

13-9. AIR OUTLET SHUTTER PLATE (20 SET, 2 PCS/SET)

Part No.	PAC-SG06SP-E
Applied Service Ref.	PLA-RP1.6,2,2.5,3,4,5,6AA.UK PLA-RP3,4,5,6AA1.UK

Mr. SLIM™

 **mitsubishi electric corporation**

HEAD OFFICE : MITSUBISHI DENKI BLDG., 2-2-3 MARUNOUCHI CHIYODA-KU , TOKYO 100-8310 , JAPAN

©Copyright 2003 MITSUBISHI ELECTRIC ENGINEERING CO., LTD.
Distributed in May 2005 No. OC297 REVISED EDITION-E PDF 8
Distributed in Feb. 2005 No. OC297 REVISED EDITION-D PDF 8
Distributed in Jul. 2004 No. OC297 REVISED EDITION-C PDF 8
Distributed in Jun. 2004 No. OC297 REVISED EDITION-B PDF 8
Distributed in Dec. 2003 No. OC297 REVISED EDITION-A PDF 8
Distributed in Jun. 2003 No. OC297
Made in Japan

New publication, effective May 2005.
Specifications subject to change without notice