

# mitsubishi electric

## Air-Conditioners OUTDOOR UNIT

# PUH-P8, 10MYA

CE

**FOR INSTALLER  
FÜR INSTALLATEUR  
POUR L'INSTALLATEUR  
PARA EL INSTALADOR**

**PER L'INSTALLATORE  
VOOR DE INSTALLATEUR  
FÖR INSTALLATÖREN  
PARA O INSTALADOR**

GB

D

F

E

## INSTALLATION MANUAL

For safe and correct use, please read this installation manual thoroughly before installing the air-conditioner unit.

## INSTALLATIONSHANDBUCH

Zum sicheren und ordnungsgemäßen Gebrauch der Klimageräte das Installationshandbuch gründlich durchlesen.

## MANUEL D'INSTALLATION

Veillez lire le manuel d'installation en entier avant d'installer ce climatiseur pour éviter tout accident et vous assurer d'une utilisation correcte.

## MANUAL DE INSTALACIÓN

Para un uso seguro y correcto, lea detalladamente este manual de instalación antes de montar la unidad de aire acondicionado.

## MANUALE DI INSTALLAZIONE

Per un uso sicuro e corretto, leggere attentamente questo manuale di installazione prima di installare il condizionatore d'aria.

## INSTALLATIEHANDLEIDING

Voor een veilig en juist gebruik moet u deze installatiehandleiding grondig doorlezen voordat u de airconditioner installeert.

## INSTALLATIONSMANUAL

Läs denna installationsmanual noga för säkert och korrekt bruk innan luftkonditioneringen installeras.

## MANUAL DE INSTALAÇÃO

Para segurança e utilização correctas, leia atentamente este manual de instalação antes de instalar a unidade de ar condicionado.

I

NL

SW

P

#### 4 [Fig. 4.0.1]

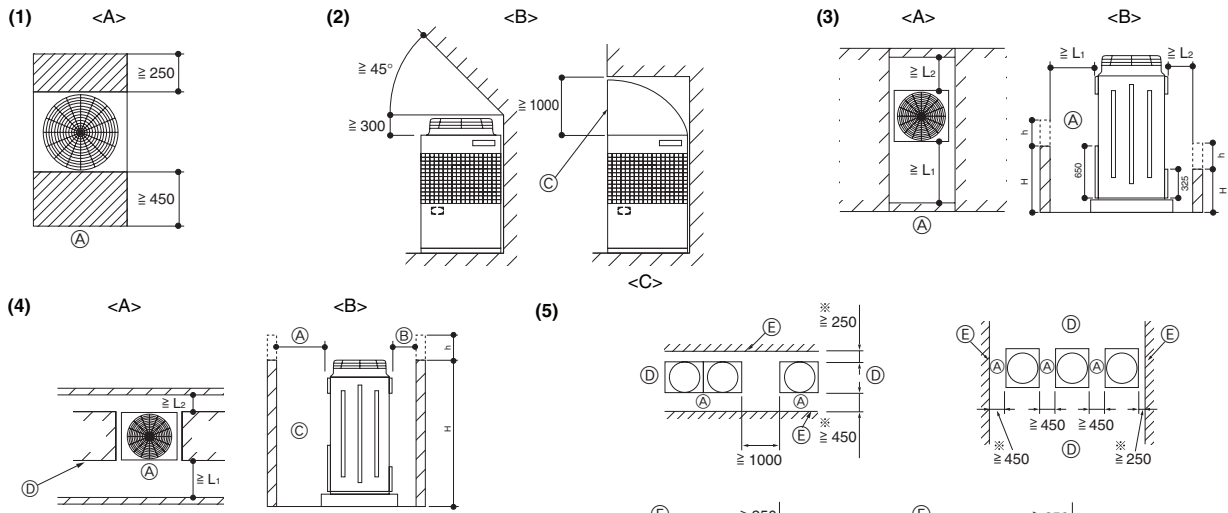

#### 5 [Fig. 5.0.1]

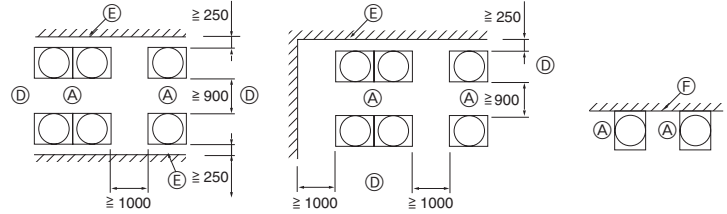
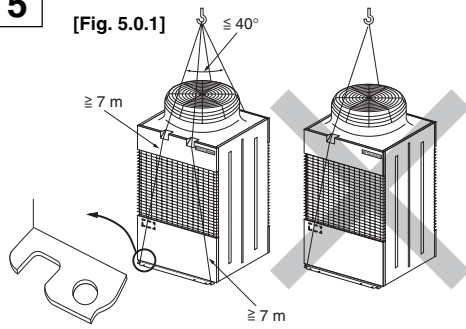

- <A> Top view  
<B> Side view  
<C> When there is little space up to an obstruction  
 (A) Front (B) No restrictions on wall height (left and right)  
 (C) Air outlet guide (Procured at the site) (D) Must be open  
 (E) Wall height (H) (F) No restrictions on wall height  
 L1: 450 L2: 250

#### 6 6.1

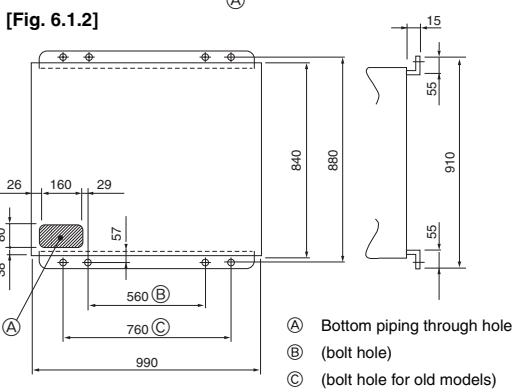
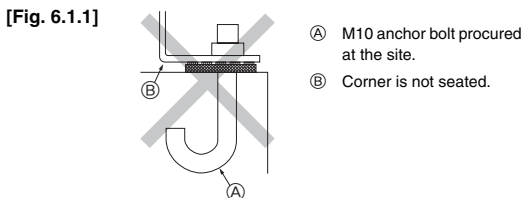

#### 6.2

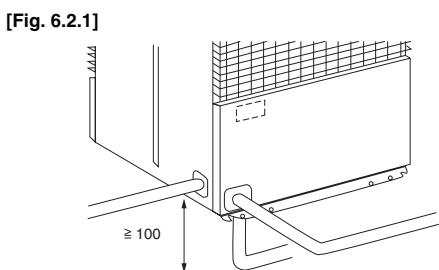

#### 7 7.2

[Fig. 7.2.1]

##### (1) Single

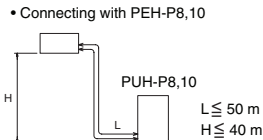

##### (2) Twin

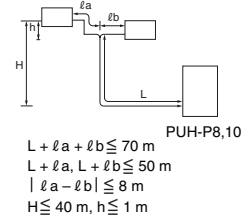

##### • Connecting with PEH-P16, 20

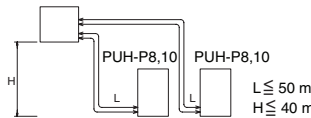

##### (3) Triple

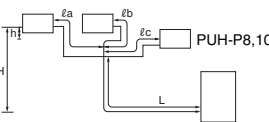

##### (4) Four

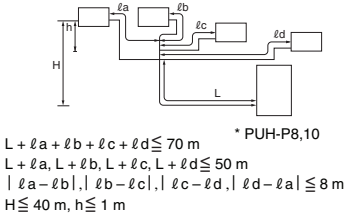

A (mm)		
[A] Outdoor unit	[B] Gas pipe size	[C] Liquid pipe size
PUH-P8	ø25.4	ø12.7
PUH-P10	ø28.58	ø12.7

B (mm)		
[D] Indoor unit	[B] Gas pipe size	[C] Liquid pipe size
(P)1.6~(P)3	ø15.88	ø9.52
(P)4~(P)5	ø19.05	ø9.52
(P)8	ø25.4	ø12.7
P10	ø28.58	ø12.7
P16	ø25.4	ø12.7
P20	ø28.58	ø12.7

[Fig. 8.2.2]

<A> [Ball valve (gas side)]  
(This figure shows the valve in the fully open state.)

<B> [Ball valve (liquid side)]

[Fig. 8.2.3]

[Fig. 8.2.1]

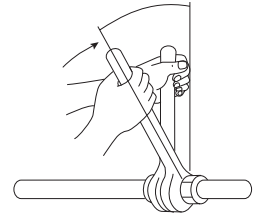
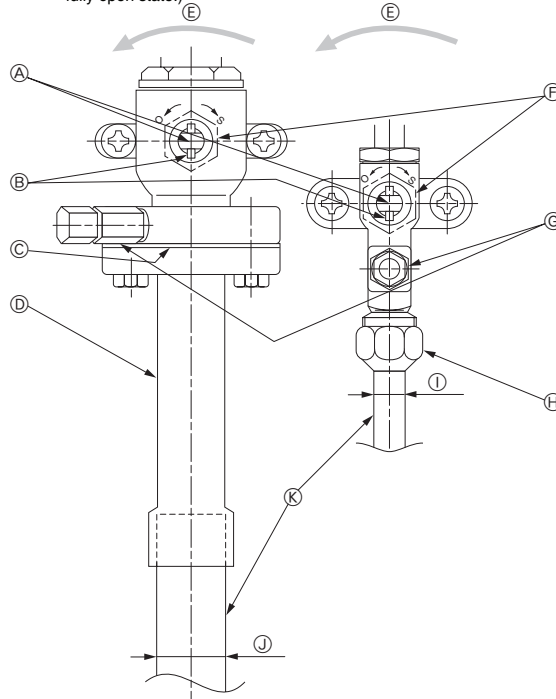
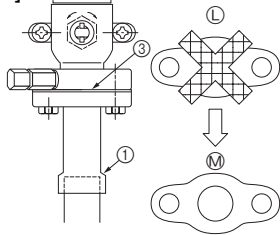

- A Valve stem
- B Stopper pin
- C Packing (Accessory)
- D Connecting pipe (Accessory)
- E Open (Operate slowly)
- F Cap, copper packing
- G Service port
- H Flare nut
- I  $\phi 12.7$  PUH-P8, 10
- J  $\phi 25.4$  PUH-P8  
 $\phi 28.58$  PUH-P10
- K Field piping
- L Close-packed packing
- M Hollow packing

8.3

[Fig. 8.3.1]

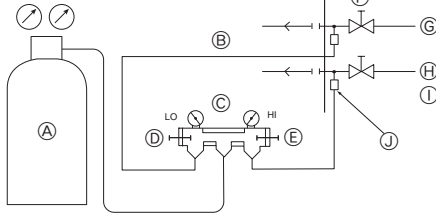

- A Nitrogen gas
- B To indoor unit
- C System analyzer
- D Lo Knob
- E Hi Knob
- F Stop valve
- G Liquid pipe
- H Gas pipe
- I Outdoor unit
- J Service port

[Fig. 8.3.2]

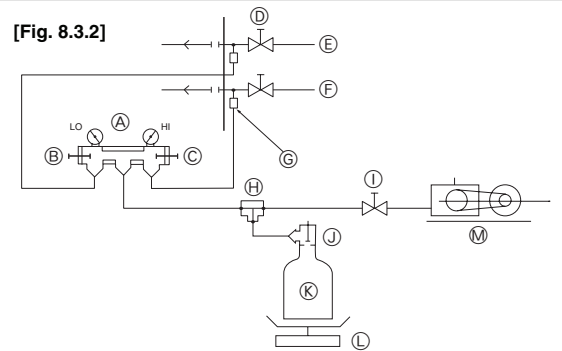

- A System analyzer
- B Lo Knob
- C Hi Knob
- D Ball valve
- E Liquid pipe
- F Gas pipe
- G Service port
- H Three-way joint
- I Valve
- J Service port
- K Cylinder
- L Scale
- M Vacuum pump

[Fig. 8.3.3]

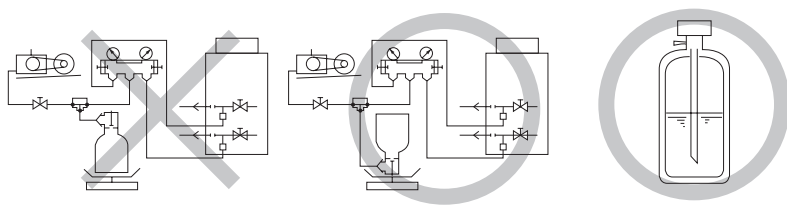

8.4

[Fig. 8.4.1]

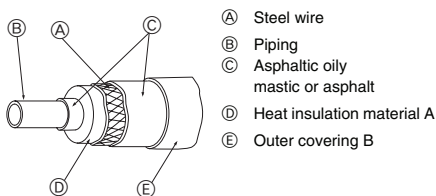

- A Steel wire
- B Piping
- C Asphaltic oily mastic or asphalt
- D Heat insulation material A
- E Outer covering B

[Fig. 8.4.3]

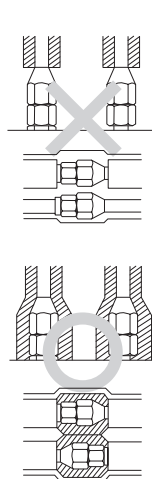

[Fig. 8.4.4]

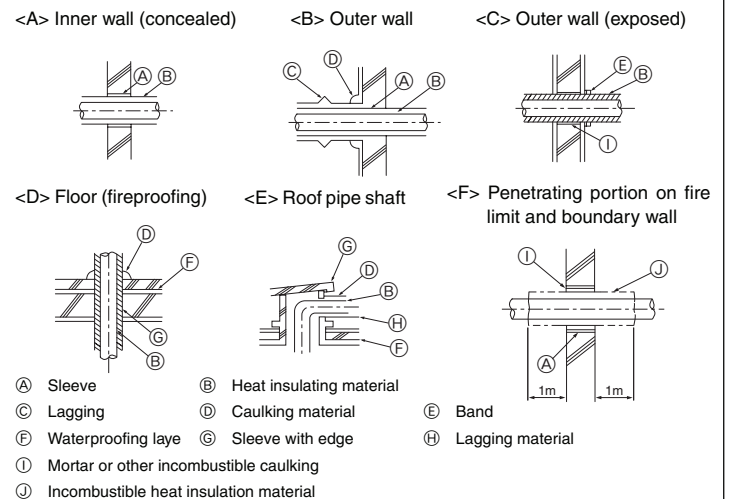

- A Sleeve
- B Heat insulating material
- C Lagging
- D Caulking material
- E Band
- F Waterproofing layer
- G Sleeve with edge
- H Lagging material
- I Mortar or other incombustible caulking
- J Incombustible heat insulation material

[Fig. 8.4.2]

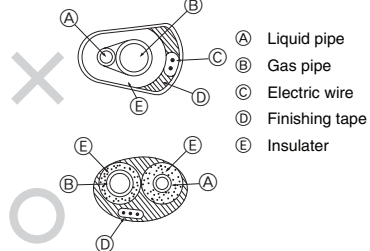

- A Liquid pipe
- B Gas pipe
- C Electric wire
- D Finishing tape
- E Insulator

[Fig. 9.2.1]

(1) Connecting with PEH-P8, 10

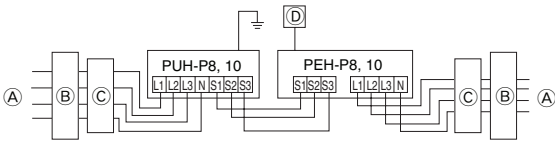

(4) Connecting with PEH-P16, 20

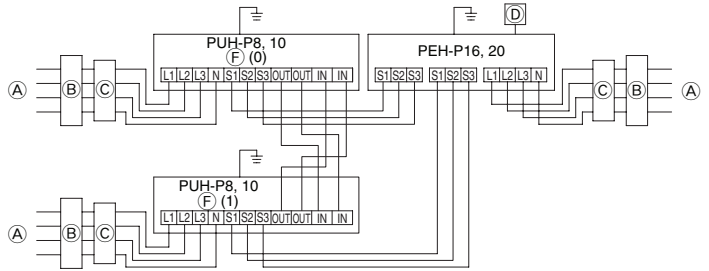

(2) Free multi - component system

① Without heater

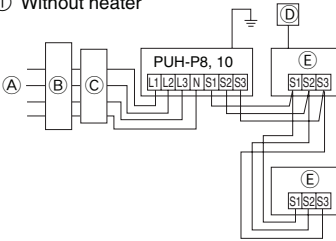

② With heater

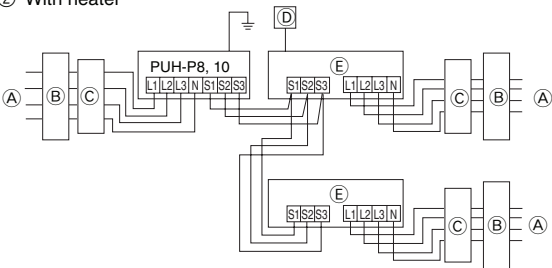

(3) Grouping (16 outdoor units)

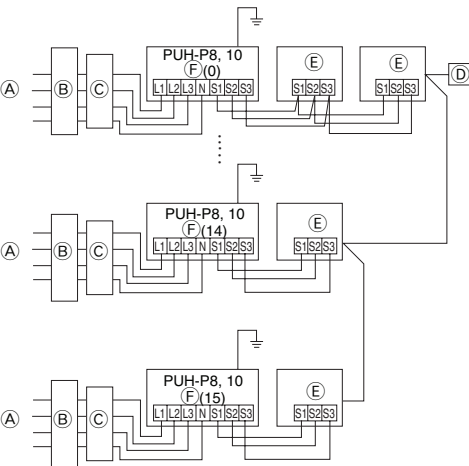

(5) Grouping (16 outdoor units) [Connecting with PEH-P16, 20]

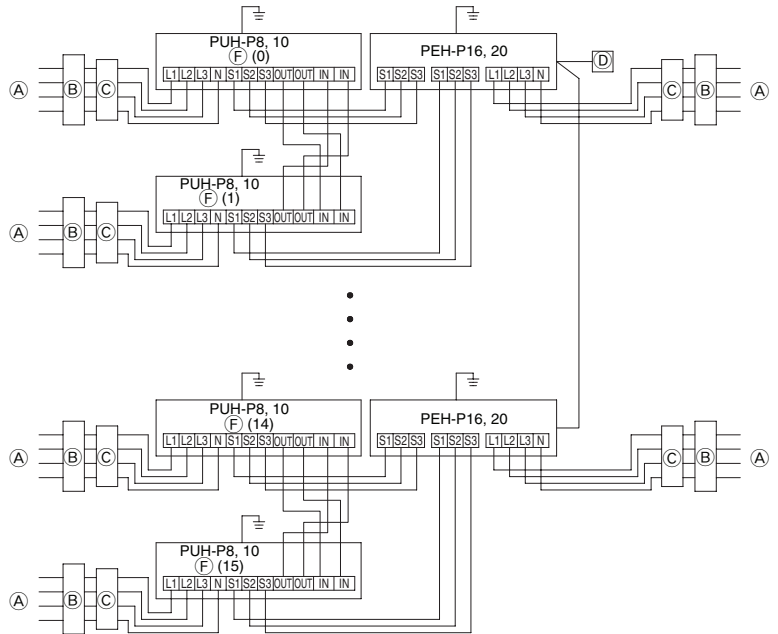

- (A) Power supply
- (B) Breaker
- (C) Switch box
- (D) Remote controller
- (E) Indoor unit
- (F) Address

[Fig. 9.3.1]

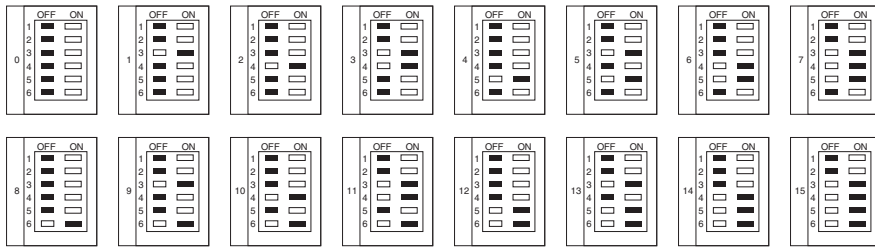

9.4

[Fig. 9.4.1]

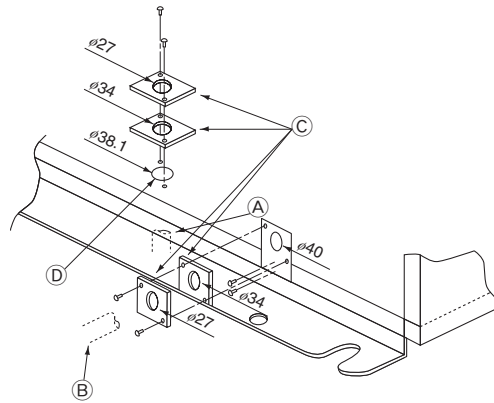

- Ⓐ When installing conduct from bottom panel
- Ⓑ When installing conduct from front panel
- Ⓒ Mounting plate (attached)
- Ⓓ Knock-out hole

# Contents

1. Safety precautions .....	6	8. Additional Refrigerant Charge .....	9
1.1. Before installation and electric work .....	6	8.1. Additional refrigerant charge .....	9
1.2. Precautions for devices that use R407C refrigerant .....	6	8.2. Caution for piping connection/valve operation .....	9
1.3. Before getting installed .....	7	8.3. Airtight test, evacuation, and refrigerant charging .....	10
1.4. Before getting installed (moved) - electrical work .....	7	8.4. Thermal insulation of refrigerant piping .....	11
1.5. Before starting the test run .....	7	9. Wiring .....	11
2. Specifications .....	7	9.1. Caution .....	11
3. Confirmation of parts attached .....	7	9.2. Wiring and fitting capacities .....	11
4. Space required around unit .....	8	9.3. Address settings .....	12
5. Lifting method and weight of product .....	8	9.4. Location of wiring connections .....	12
6. Installation of unit .....	8	10. Test run .....	12
6.1. Installation .....	8	10.1. Test run .....	12
6.2. Connecting direction for refrigerant piping .....	8	10.2. How to handle problems with the test run .....	12
7. Refrigerant piping installation .....	8	10.3. The following occurrences are not problems or errors .....	14
7.1. Caution .....	8		
7.2. Refrigerant piping system .....	9		

## 1. Safety precautions

### 1.1. Before installation and electric work

- ▶ Before installing the unit, make sure you read all the “Safety precautions”.
- ▶ The “Safety precautions” provide very important points regarding safety. Make sure you follow them.

#### Symbols used in the text





##### **Warning:**

Describes precautions that should be observed to prevent danger of injury or death to the user.

##### **Caution:**

Describes precautions that should be observed to prevent damage to the unit.

#### Symbols used in the illustrations

-  : Indicates an action that must be avoided.
-  : Indicates that important instructions must be followed.
-  : Indicates a part which must be grounded.
-  : Beware of electric shock. (This symbol is displayed on the main unit label.)  
<Color: yellow>

##### **Warning:**

**Carefully read the labels affixed to the main unit.**

##### **Warning:**

- **Ask the dealer or an authorized technician to install the air conditioner.**
  - Improper installation by the user may result in water leakage, electric shock, or fire.
- **Install the unit at a place that can withstand its weight.**
  - Inadequate strength may cause the unit to fall down, resulting in injuries.
- **Use the specified cables for wiring. Make the connections securely so that the outside force of the cable is not applied to the terminals.**
  - Inadequate connection and fastening may generate heat and cause a fire.
- **Prepare for strong winds and earthquakes and install the unit at the specified place.**
  - Improper installation may cause the unit to topple and result in injury.
- **Always use an filter and other accessories specified by Mitsubishi Electric.**
  - Ask an authorized technician to install the accessories. Improper installation by the user may result in water leakage, electric shock, or fire.
- **Never repair the unit. If the air conditioner must be repaired, consult the dealer.**
  - If the unit is repaired improperly, water leakage, electric shock, or fire may result.
- **Do not touch the heat exchanger fins.**
  - Improper handling may result in injury.
- **If refrigerant gas leaks during installation work, ventilate the room.**
  - If the refrigerant gas comes into contact with a flame, poisonous gases will be released.
- **Install the air conditioner according to this Installation Manual.**
  - If the unit is installed improperly, water leakage, electric shock, or fire may result.

- **Have all electric work done by a licensed electrician according to “Electric Facility Engineering Standard” and “Interior Wire Regulations” and the instructions given in this manual and always use a special circuit.**
  - If the power source capacity is inadequate or electric work is performed improperly, electric shock and fire may result.
- **Securely install the outdoor unit terminal cover (panel).**
  - If the terminal cover (panel) is not installed properly, dust or water may enter the outdoor unit and fire or electric shock may result.
- **When installing and moving the air conditioner to another site, do not charge the it with a refrigerant different from the refrigerant (R407C or R22) specified on the unit.**
  - If a different refrigerant or air is mixed with the original refrigerant, the refrigerant cycle may malfunction and the unit may be damaged.
- **If the air conditioner is installed in a small room, measures must be taken to prevent the refrigerant concentration from exceeding the safety limit even if the refrigerant should leak.**
  - Consult the dealer regarding the appropriate measures to prevent the safety limit from being exceeded. Should the refrigerant leak and cause the safety limit to be exceeded, hazards due to lack of oxygen in the room could result.
- **When moving and reinstalling the air conditioner, consult the dealer or an authorized technician.**
  - If the air conditioner is installed improperly, water leakage, electric shock, or fire may result.
- **After completing installation work, make sure that refrigerant gas is not leaking.**
  - If the refrigerant gas leaks and is exposed to a fan heater, stove, oven, or other heat source, it may generate noxious gases.
- **Do not reconstruct or change the settings of the protection devices.**
  - If the pressure switch, thermal switch, or other protection device is shorted and operated forcibly, or parts other than those specified by Mitsubishi Electric are used, fire or explosion may result.
- **To dispose of this product, consult your dealer.**
- **The installer and system specialist shall secure safety against leakage according to local regulation or standards.**
  - Following standards may be applicable if local regulation are not available.
- **Pay a special attention to the place, such as a basement, etc. where refrigeration gas can stay, since refrigeration is heavier than the air.**
- **The appliance is not intended for use by young children or infirm persons without supervision.**
- **Young children should be supervised to ensure that they do not play with the appliance.**

### 1.2. Precautions for devices that use R407C refrigerant

##### **Caution:**

- **Do not use the existing refrigerant piping.**
  - The old refrigerant and refrigerator oil in the existing piping contains a large amount of chlorine which may cause the refrigerator oil of the new unit to deteriorate.
- **Use refrigerant piping made of phosphorus deoxidized copper and copper alloy seamless pipes and tubes. In addition, be sure that the inner and outer surfaces of the pipes are clean and free of hazardous sulphur, oxides, dust/dirt, shaving particles, oils, moisture, or any other contaminant.**
  - Contaminants on the inside of the refrigerant piping may cause the refrigerant residual oil to deteriorate.
- **Store the piping to be used during installation indoors and keep both ends of the piping sealed until just before brazing. (Store elbows and other joints in a plastic bag.)**
  - If dust, dirt, or water enters the refrigerant cycle, deterioration of the oil and compressor trouble may result.

- **Use ester oil, ether oil or alkylbenzene (small amount) as the refrigerant oil to coat flares and flange connections.**
  - The refrigerant oil will degrade if it is mixed with a large amount of mineral oil.
- **Use liquid refrigerant to fill the system.**
  - If gas refrigerant is used to seal the system, the composition of the refrigerant in the cylinder will change and performance may drop.
- **Do not use a refrigerant other than R407C.**
  - If another refrigerant (R22, etc.) is used, the chlorine in the refrigerant may cause the refrigerant oil to deteriorate.
- **Use a vacuum pump with a reverse flow check valve.**
  - The vacuum pump oil may flow back into the refrigerant cycle and cause the refrigerant oil to deteriorate.
- **Do not use the following tools that are used with conventional refrigerants.**  
(Gauge manifold, charge hose, gas leak detector, reverse flow check valve, refrigerant charge base, refrigerant recovery equipment)
  - If the conventional refrigerant and refrigerant oil are mixed in the R407C, the refrigerant may deteriorate.
  - If water is mixed in the R407C, the refrigerant oil may deteriorate.
  - Since R407C does not contain any chlorine, gas leak detectors for conventional refrigerants will not react to it.
- **Do not use a charging cylinder.**
  - Using a charging cylinder may cause the refrigerant to deteriorate.
- **Be especially careful when managing the tools.**
  - If dust, dirt, or water gets in the refrigerant cycle, the refrigerant may deteriorate.

- **Install the power cable so that tension is not applied to the cable.**
  - Tension may cause the cable to break and generate heat and cause a fire.
- **Install an leak circuit breaker, as required.**
  - If an leak circuit breaker is not installed, electric shock may result.
- **Use power line cables of sufficient current carrying capacity and rating.**
  - Cables that are too small may leak, generate heat, and cause a fire.
- **Use only a circuit breaker and fuse of the specified capacity.**
  - A fuse or circuit breaker of a larger capacity or a steel or copper wire may result in a general unit failure or fire.
- **Do not wash the air conditioner units.**
  - Washing them may cause an electric shock.
- **Be careful that the installation base is not damaged by long use.**
  - If the damage is left uncorrected, the unit may fall and cause personal injury or property damage.
- **Install the drain piping according to this Installation Manual to ensure proper drainage. Wrap thermal insulation around the pipes to prevent condensation.**
  - Improper drain piping may cause water leakage and damage to furniture and other possessions.
- **Be very careful about product transportation.**
  - Only one person should not carry the product if it weighs more than 20 kg.
  - Some products use PP bands for packaging. Do not use any PP bands for a means of transportation. It is dangerous.
  - Do not touch the heat exchanger fins. Doing so may cut your fingers.
  - When transporting the outdoor unit, suspend it at the specified positions on the unit base. Also support the outdoor unit at four points so that it cannot slip sideways.
- **Safely dispose of the packing materials.**
  - Packing materials, such as nails and other metal or wooden parts, may cause stabs or other injuries.
  - Tear apart and throw away plastic packaging bags so that children will not play with them. If children play with a plastic bag which was not torn apart, they face the risk of suffocation.

### 1.3. Before getting installed

#### ⚠ Caution:

- **Do not install the unit where combustible gas may leak.**
  - If the gas leaks and accumulates around the unit, an explosion may result.
- **Do not use the air conditioner where food, pets, plants, precision instruments, or artwork are kept.**
  - The quality of the food, etc. may deteriorate.
- **Do not use the air conditioner in special environments.**
  - Oil, steam, sulfuric smoke, etc. can significantly reduce the performance of the air conditioner or damage its parts.
- **When installing the unit in a hospital, communication station, or similar place, provide sufficient protection against noise.**
  - The inverter equipment, private power generator, high-frequency medical equipment, or radio communication equipment may cause the air conditioner to operate erroneously, or fail to operate. On the other hand, the air conditioner may affect such equipment by creating noise that disturbs medical treatment or image broadcasting.
- **Do not install the unit on a structure that may cause leakage.**
  - When the room humidity exceeds 80 % or when the drain pipe is clogged, condensation may drip from the indoor unit. Perform collective drainage work together with the outdoor unit, as required.

### 1.4. Before getting installed (moved) - electrical work

#### ⚠ Caution:

- **Ground the unit.**
  - Do not connect the ground wire to gas or water pipes, lightning rods, or telephone ground lines. Improper grounding may result in electric shock.
- **The reverse phase of L lines (L1, L2, L3) can be detected (Error cord: 4103), but the reverse phase of L lines and N line can be not be detected.**
  - The some electric parts should be damaged when power is supplied under the miss wiring.

### 1.5. Before starting the test run

#### ⚠ Caution:

- **Turn on the power at least 12 hours before starting operation.**
  - Starting operation immediately after turning on the main power switch can result in severe damage to internal parts. Keep the power switch turned on during the operational season.
- **Do not touch the switches with wet fingers.**
  - Touching a switch with wet fingers can cause electric shock.
- **Do not touch the refrigerant pipes during and immediately after operation.**
  - During and immediately after operation, the refrigerant pipes are may be hot and may be cold, depending on the condition of the refrigerant flowing through the refrigerant piping, compressor, and other refrigerant cycle parts. Your hands may suffer burns or frostbite if you touch the refrigerant pipes.
- **Do not operate the air conditioner with the panels and guards removed.**
  - Rotating, hot, or high-voltage parts can cause injuries.
- **Do not turn off the power immediately after stopping operation.**
  - Always wait at least five minutes before turning off the power. Otherwise, water leakage and trouble may occur.

#### Note:

1. **The total capacity of connected indoor unit models represents the total sum of the figures expressed in the indoor model name.**
2. **Combinations in which the total capacity of the connected indoor units exceeds the capacity of the outdoor unit will reduce the capacity of each indoor unit below the rated capacity during simultaneous operation. Therefore, if circumstances allows, combine indoor units within the capacity of the outdoor unit.**

## 2. Specifications

Model	PUH-P8MYA		PUH-P10MYA
Noise level	56 dB <A>		57 dB <A>
Net weight	215 kg		220 kg
Maximum refrigerant pressure	3.3 MPa		
External static pressure	0 Pa		
Indoor units	Quantity	1 ~ 4	
Operation temperature	Cooling mode: - 5 °CDB ~ 46 °CDB Heating mode: - 12 °CWB ~ 18 °CWB		

## 3. Confirmation of parts attached

- ① Conduit mounting plate × 3
- ② Tapping screw M4 × 4
- ③ Connecting pipe × 1 (Connecting pipe is fixed with the unit.)
- ④ Packing (inside ø23, outside ø35) × 1





- ⑥ You must use one of the following (separately sold) junction pipe sets for the junction area.

Outdoor-Unit Type	Junction-Set Type (multidistributor)				
	Twin	Triple			Four
	50 : 50	33 : 33 : 33	25 : 25 : 50	20 : 40 : 40	25 : 25 : 25 : 25
PUH-P8, 10	SDD-50WSA-E	SDT-111SA-E	SDT-112SA-E	SDT-122SA-E	SDT-1111SA-E

- ⑦ When the diameter of the designated refrigerant piping is different from the diameter of the branch piping, either cut the connecting portion off with a pipe cutter, or use an adapter to match the diameters.
- ⑧ **Use liquid refrigerant to fill the system.**
- ⑨ Never use refrigerant to perform an air purge. Always evacuate using a vacuum pump.
- ⑩ Always insulate the piping properly. Insufficient insulation will result in a decline in heating/cooling performance, water drops from condensation and other such problems.
- ⑪ When connecting the refrigerant piping, make sure the ball valve of the outdoor unit is completely closed (the factory setting) and do not operate it until the refrigerant piping for the outdoor and indoor units has been connected, a refrigerant leakage test has been performed and the evacuation process has been completed.
- ⑫ Always use a non-oxidizing brazing material for brazing the parts. If a non-oxidizing brazing material is not used, it could cause clogging or damage to the compressor unit.
- ⑬ **Never perform outdoor unit piping connection work when it is raining.**

### ⚠ Warning:

**When installing and moving the unit, do not charge it with refrigerant other than the refrigerant specified on the unit.**

- Mixing of a different refrigerant, air, etc. may cause the refrigerant cycle to malfunction and result in severe damage.

### ⚠ Caution:

- **Use a vacuum pump with a reverse flow check valve. (For R407C models)**
  - If the vacuum pump does not have a reverse flow check valve, the vacuum pump oil may flow back into the refrigerant cycle and cause deterioration of the refrigerant oil and other trouble.
- **Do not use the tools shown below used with conventional refrigerant. (For R407C models)**

**(Gauge manifold, charge hose, gas leak detector, check valve, refrigerant charge base, vacuum gauge, refrigerant recovery equipment)**

  - Mixing of conventional refrigerant and refrigerant oil may cause the refrigerant oil to deteriorate.
  - Mixing of water will cause the refrigerant oil to deteriorate.
  - R407C refrigerant does not contain any chlorine. Therefore, gas leak detectors for conventional refrigerants will not react to it.
- **Manage the tools more carefully than normal. (For R407C models)**
  - If dust, dirt, or water gets in the refrigerant cycle, the refrigerant oil will deteriorate.
- **Never use existing refrigerant piping. (For R407C models)**
  - The large amount of chlorine in conventional refrigerant and refrigerant oil in the existing piping will cause the new refrigerant to deteriorate.
- **Store the piping to be used during installation indoors and keep both ends of the piping sealed until just before brazing.**
  - If dust, dirt, or water gets into the refrigerant cycle, the oil will deteriorate and the compressor may fail.
- **Do not use a charging cylinder. (For R407C models)**
  - Using a charging cylinder may cause the refrigerant to deteriorate.
- **Do not use special detergents for washing piping.**

## 7.2. Refrigerant piping system

### Connection Example

[Fig. 7.2.1] (P.2)

- |                    |                               |
|--------------------|-------------------------------|
| Ⓐ Outdoor unit     | (1) Single,                   |
| Ⓑ Gas pipe size    | • Connecting with PEH-P8, 10  |
| Ⓒ Liquid pipe size | • Connecting with PEH-P16, 20 |
| Ⓓ Indoor unit      | (2) Twin                      |
|                    | (3) Triple                    |
|                    | (4) Four                      |

### ⚠ Caution:

- **Total bends are 15 units, and max. bends are 8 units within L + ℓ<sub>a</sub>, L + ℓ<sub>b</sub>, L + ℓ<sub>c</sub> and L + ℓ<sub>d</sub>.**

## 8. Additional Refrigerant Charge

### 8.1. Additional refrigerant charge

Model	Amount of infusion of coolant at ex-factory	Additional refrigerant charge
PUH-P8	6.0 kg	$0.026 \times L + 0.014 \times (\ell_a + \ell_b + \ell_c + \ell_d) + 1.7 \times \text{amount of indoor unit. (kg)}$
PUH-P10	6.5 kg	$0.026 \times L + 0.014 \times (\ell_a + \ell_b + \ell_c + \ell_d) + 1.7 \times \text{amount of indoor unit. (kg)}$

L: Main section actual length  $\ell_a + \ell_b + \ell_c + \ell_d$ : Join section actual length  
The value of calculation result at the second decimal place must be rounded up to the first decimal place.

(e.g. 2.22 kg must be rounded up to 2.3 kg)

### 8.2. Caution for piping connection/valve operation

- Conduct piping connection and valve operation accurately.
- The gas side connecting pipe is being assembled for shipment.
  - ① For brazing to the connecting pipe with flange, remove the connecting pipe with flange from the ball valve, and braze it at the outside of the unit.
  - ② During the time when removing the connecting pipe with flange, seal the flange surface of ball valve to prevent the entry of dust into the valve.
  - ③ The refrigerant circuit is closed with a round, close-packed packing at the shipment to prevent gas leak between flanges. As no operation can be done under this state, be sure replace the packing with the hollow packing attached at the piping connection.
  - ④ At the mounting of the hollow packing, wipe off dust attached on the flange sheet surface and the packing. Coat refrigerating machine oil (Ester oil, ether oil or alkylbenzene [small amount]) onto both surfaces of the packing.

[Fig. 8.2.1] (P.3)

- After evacuation and refrigerant charge, ensure that the handle is fully open. If operating with the valve closed, abnormal pressure will be imparted to the high- or low-pressure side of the refrigerant circuit, giving damage to the compressor, four-way valve, etc.
- Determine the amount of additional refrigerant charge by using the formula, and charge refrigerant additionally through the service port after completing piping connection work.
- After completing work, tighten the service port and cap securely not to generate gas leak.

[Fig. 8.2.2] (P.3)

- <A> [Ball valve (gas side)]  
(This figure shows the valve in the fully open state.)
- <B> [Ball valve (liquid side)]
- Ⓐ Valve stem  
[Fully closed at the factory, when connecting the piping, when evacuating, and when charging additional refrigerant. Open fully after the operations above are completed.]
  - Ⓑ Stopper pin [Prevents the valve stem from turning 90° or more.]
  - Ⓒ Packing (Accessory)  
[Manufacturer: Nichiasu corporation]  
[Type: T/#1991-NF]
  - Ⓓ Connecting pipe (Accessory)  
[Use packing and securely install this pipe to the valve flange so that gas leakage will not occur. (Tightening torque: 25 N·m (250 kg·cm)) Coat both surfaces of the packing with refrigerant oil (Ester oil, ether oil or alkylbenzene [small amount]).]
  - Ⓔ Open (Operate slowly)
  - Ⓕ Cap, copper packing  
[Remove the cap and operate the valve stem. Always reinstall the cap after operation is completed. (Valve stem cap tightening torque: 25 N·m (250 kg·cm) or more)]
  - Ⓖ Service port  
[Use this port to evacuate the refrigerant piping and add an additional charge at the site.  
Open and close the port using a double-ended wrench.  
Always reinstall the cap after operation is completed. (Service port cap tightening torque: 14 N·m (140 kg·cm) or more)]

- ⓑ Flare nut  
[Tightening torque: 120 N-m (1200 kg-cm)  
Loosen and tighten this nut using a double-ended wrench.  
Coat the flare contact surface with refrigerator oil (Ester oil, ether oil or alkylbenzene [small amount]).]
- ⓐ  $\phi$ 12.7 PUH-P8, 10
- ⓓ  $\phi$ 25.4 PUH-P8  
 $\phi$ 28.58 PUH-P10
- Ⓚ Field piping  
[Brazed to the connecting pipe. (When brazing, use unoxidized brazing.)]
- Ⓛ Close-packed packing
- Ⓜ Hollow packing

Appropriate tightening torque by torque wrench:

Copper pipe external dia. (mm)	Tightening torque (N-m) / (kg-cm)
$\phi$ 6.35	14 to 18 / 140 to 180
$\phi$ 9.52	35 to 42 / 350 to 420
$\phi$ 12.7	50 to 57.5 / 500 to 575
$\phi$ 15.88	75 to 80 / 750 to 800

Tightening angle standard:

Pipe diameter (mm)	Tightening angle (°)
$\phi$ 6.35, $\phi$ 9.52	60 to 90
$\phi$ 12.7, $\phi$ 15.88	30 to 60

[Fig. 8.2.3] (P.3)

Note:

If a torque wrench is not available, use the following method as a standard: When you tighten the flare nut with a wrench, you will reach a point where the tightening torque will abruptly increase. Turn the flare nut beyond this point by the angle shown in the table above.

### ⚠ Caution:

- **Always remove the connecting pipe from the ball valve and braze it outside the unit.**  
- Brazing the connecting pipe while it is installed will heat the ball valve and cause trouble or gas leakage. The piping, etc. inside the unit may also be burned.
- **Use ester oil, ether oil or alkylbenzene (small amount) as the refrigerator oil to coat flares and flange connections. (For R407C models)**  
- The refrigerator oil will degrade if it is mixed with a large amount of mineral oil.

## 8.3. Airtight test, evacuation, and refrigerant charging

### ① Airtight test

Perform with the stop valve of the outdoor unit closed, and pressurize the connection piping and the indoor unit from the service port provided on the stop valve of the outdoor unit. (Always pressurize from both the liquid pipe and the gas pipe service ports.)

[Fig. 8.3.1] (P.3)

- |                |                  |                   |
|----------------|------------------|-------------------|
| Ⓐ Nitrogen gas | Ⓑ To indoor unit | Ⓒ System analyzer |
| Ⓓ Lo Knob      | Ⓔ Hi Knob        | Ⓕ Stop valve      |
| Ⓔ Liquid pipe  | Ⓖ Gas pipe       | Ⓗ Outdoor unit    |
| Ⓙ Service port |                  |                   |

<For R407C models>

The method of conducting the airtight test is basically the same as for R22 models. However, since the restrictions have a large affect on deterioration of the refrigerator oil, always observe them. Also, with nonazeotropic refrigerant (R407C, etc.), gas leakage causes the composition to change and affects performance. Therefore, perform the airtightness test cautiously.

Airtight test procedure	Restriction
<p>1. Nitrogen gas pressurization</p> <p>(1) After pressurizing to the design pressure (3.3 MPa) using nitrogen gas, let stand for about one day. If the pressure does not drop, airtightness is good. However, if the pressure drops, since the leaking point is unknown, the following bubble test may also be performed.</p> <p>(2) After the pressurization described above, spray the flare connection parts, brazed parts, flanges, and other parts that may leak with a bubbling agent (Kyuboflex, etc.) and visually check for bubbles.</p> <p>(3) After the airtight test, wipe off the bubbling agent.</p>	<ul style="list-style-type: none"> <li>• If a flammable gas or air (oxygen) is used as the pressurization gas, it may catch fire or explode.</li> </ul>
<p>2. Pressurization using refrigerant gas and nitrogen gas</p> <p>(1) Pressurizing to a gas pressure of approximately 0.2 MPa, pressurize to the design pressure (2.94 MPa) using nitrogen gas. However, do not pressurize at one time. Stop during pressurization and check that the pressure does not drop.</p> <p>(2) Check for gas leaks by checking the flare connection parts, brazed parts, flanges, and other parts which may leak using an R407C compatible electric leak detector.</p> <p>(3) This test may be used together the with bubble type gas leak test.</p>	<ul style="list-style-type: none"> <li>• Do not use a refrigerant other than that indicated on the unit.</li> <li>• Sealing with gas from a cylinder will cause the composition of the refrigerant in the cylinder to change. (For R407C models)</li> <li>• Use a pressure gauge, charge box, and other parts especially for R407C. (For R407C models)</li> <li>• An electric leak detector for R22 cannot detect leaks of R407C.</li> <li>• Do not use a haloid torch. (Leaks cannot be detected.)</li> </ul>

### ② Evacuation

Evacuate with the ball valve of the outdoor unit closed and evacuate both the connection piping and the indoor unit from the service port provided on the ball valve of the outdoor unit using a vacuum pump. (Always evacuate from the service port of both the liquid pipe and the gas pipe.) After the vacuum reaches 5 Torr, continue evacuation for at least one hour or more.

\* Never perform air purging using refrigerant.

[Fig. 8.3.2] (P.3)

- |                   |                   |            |
|-------------------|-------------------|------------|
| Ⓐ System analyzer | Ⓑ Lo Knob         | Ⓒ Hi Knob  |
| Ⓓ Ball valve      | Ⓔ Liquid pipe     | Ⓕ Gas pipe |
| Ⓔ Service port    | Ⓖ Three-way joint | Ⓗ Valve    |
| Ⓙ Valve           | Ⓖ Cylinder        | Ⓖ Scale    |
| Ⓜ Vacuum pump     |                   |            |

Note:

- **Always add an appropriate amount of refrigerant. Also always seal the system with liquid refrigerant. Too much or too little refrigerant will cause trouble.**
- **Use a gauge manifold, charging hose, and other parts for the refrigerant indicated on the unit.**

- **Use a gravimeter. (One that can measure down to 0.1 kg.)**
- **Use a vacuum pump with a reverse flow check valve. (For R407C models)**  
**(Recommended vacuum gauge: ROBINAIR 14830A Thermistor Vacuum Gauge)**  
**Also use a vacuum gauge that reaches 0.5 Torr or greater after operating for five minutes.**

### ③ Refrigerant Charging (For R407C models)

Since the refrigerant used with the unit is nonazeotropic, it must be charged in the liquid state. Consequently, when charging the unit with refrigerant from a cylinder, if the cylinder does not have a syphon pipe, charge the liquid refrigerant by turning the cylinder upside-down as shown below. If the cylinder has a syphon pipe like that shown in the figure at the right, the liquid refrigerant can be charged with the cylinder standing upright. Therefore, give careful attention to the cylinder specifications. If the unit should be charged with gas refrigerant, replace all the refrigerant with new refrigerant. Do not use the refrigerant remaining in the cylinder.

[Fig. 8.3.3] (P.3)

## 8.4. Thermal insulation of refrigerant piping

Be sure to give insulation work to refrigerant piping by covering liquid pipe and gas pipe separately with enough thickness heat-resistant polyethylene, so that no gap is observed in the joint between indoor unit and insulating material, and insulating materials themselves. When insulation work is insufficient, there is a possibility of condensation drip, etc. Pay special attention to insulation work to ceiling plenum.

[Fig. 8.4.1] (P.3)

- Ⓐ Steel wire
- Ⓑ Piping
- Ⓒ Asphaltic oily mastic or asphalt
- Ⓓ Heat insulation material A
- Ⓔ Outer covering B

Heat insulation material A	Glass fiber + Steel wire	
	Adhesive + Heat - resistant polyethylene foam + Adhesive tape	
Outer covering B	Indoor	Vinyl tape
	Floor exposed	Water-proof hemp cloth + Bronze asphalt
	Outdoor	Water-proof hemp cloth + Zinc plate + Oily paint

**Note:**

- When using polyethylene cover as covering material, asphalt roofing shall not be required.
- No heat insulation must be provided for electric wires.

## 9. Wiring

### 9.1. Caution

- ① Follow ordinance of your governmental organization for technical standard related to electrical equipment, wiring regulations and guidance of each electric power company.
- ② Set up the outdoor unit so that the wiring for the remote controller and the M-NET (MELANS) wiring do not produce electrical interference with the power supply cable. (Do not route them together in the same conduit.)
- ③ Be sure to provide designated grounding work to outdoor unit.
- ④ Give some allowance to wiring for electrical part box of indoor and outdoor units, because the box is sometimes removed at the time of service work.
- ⑤ In the indoor/outdoor connection wiring, the power and signals wiring are contained in the same multiconductor cable. Since the cable is polarized, be sure the connection is according to the terminal number.
- ⑥ For detailed information about the power supply cable, see the manual supplied with the indoor unit.

### 9.2. Wiring and fitting capacities

#### (1) PUH-P8, 10

**Main power supply wire thickness and switch capacities.**

				PUH-P8	PUH-P10
Electrical work	Main wire Outdoor	Power supply thickness *1	mm <sup>2</sup>	4 or more	6 or more
		Overcurrent protector *2	A	32	40
	Thickness of wires for remote controller and indoor unit *1		mm <sup>2</sup>	0.8 or more *3	
	Thickness of wire between indoor and outdoor unit		mm <sup>2</sup>	1.5 or more	
	Thickness of wire between outdoor and outdoor unit (connecting with PEH-P16, 20)		mm <sup>2</sup>	0.75 or more	
	Ground wire thickness		mm <sup>2</sup>	4 or more	6 or more

**Notes:**

- \*1: "Power supply thickness" indicates the thinnest allowable metal wire.
- \*2: "Overcurrent protector" indications are for when class B fuse are used.
- \*3: These wires are supplied with optional remote controller and branch piping.
- \*4: Power supply codes of parts of appliances for outdoor use shall not be lighter than polychloroprene sheathed flexible cord (design 245 IEC 57).
- \*5: A switch with at least 3 mm contact separation in each pole shall be provided by the Air conditioner installation.

[Fig. 8.4.2] (P.3)

- Ⓐ Liquid pipe
- Ⓑ Gas pipe
- Ⓒ Electric wire
- Ⓓ Finishing tape
- Ⓔ Insulator

[Fig. 8.4.3] (P.3)

### Penetrations

[Fig. 8.4.4] (P.3)

- <A> Inner wall (concealed)
- <B> Outer wall
- <C> Outer wall (exposed)
- <D> Floor (fireproofing)
- <E> Roof pipe shaft
- <F> Penetrating portion on fire limit and boundary wall
- Ⓐ Sleeve
- Ⓑ Heat insulating material
- Ⓒ Lagging
- Ⓓ Caulking material
- Ⓔ Band
- Ⓕ Waterproofing layer
- Ⓖ Sleeve with edge
- Ⓖ Lagging material
- Ⓗ Mortar or other incombustible caulking
- Ⓙ Incombustible heat insulation material

When filling a gap with mortar, cover the penetration part with steel plate so that the insulation material will not be caved in. For this part, use incombustible materials for both insulation and covering. (Vinyl covering should not be used.)

#### ⚠ Warning:

Always use the designated cable for wiring, and connect it correctly. Secure it so that the cable applies no external pressure to the terminal connection. If the connection is faulty or the cable is not fully secured, overheating or fire could result.

#### ⚠ Caution:

- Depending on the location of the unit, a current leakage breaker may be required. If a current leakage breaker is not installed, electric shock could result.
- Do not use breakers or fuses with a capacity different from the correct one. If large-capacity fuses, wire, or copper wiring are used, accident or fire may result.

Table above is an example. The selection of other capacities should be determined in accordance with the relevant standards.

#### Types of cable/cord

- Vinyl cab tire round cord: VCTF
- Vinyl insulating vinyl sheath cable round type: VVR
- Vinyl cab tire flat cord: VCTFK
- Vinyl insulating vinyl sheath cable flat type: VVF
- Vinyl insulating vinyl sheath cable for control: CVV
- 600 V vinyl cab tire cable: VCT
- Vinyl insulating vinyl sheath cable for control: CVS

#### ⚠ Warning:

Be sure to use specified cables and connect them firmly so that no external wiring force is exerted on terminal connections. Loose connections may cause heat or fire.

#### ⚠ Caution:

- Some installation sites may required installation of an earth leakage breaker. Failure to install it may result in an electric shock.
- Always use an earth leakage breaker and fuse with the specified capacity. Use of a fuse with a capacity larger than that specified, or use of a piece of wire or copper wire may cause breakdown or fire.

## Example

### [Fig. 9.2.1] (P.4)

- (1) Connecting with PEH-P8, 10
- (2) Free multi-component system
  - ① Without heater
  - ② With heater
- (3) Grouping (16 outdoor units)
- (4) Connecting with PEH-P16, 20
- (5) Grouping (16 outdoor units) [Connecting with PEH-P16, 20]
  - ① single
  - ② twin
  - Ⓐ Power supply      Ⓑ Breaker      Ⓒ Switch box
  - Ⓓ Remote controller    Ⓔ Indoor unit      Ⓕ Address

## 9.3. Address settings

### Outdoor unit address settings

- When controlling a group, the address must be set for each outdoor unit.
- During address setting, set all the dip switches SW1 (3 - 6) on the board to <when shipped from factory: all OFF>. (Address setting is not necessary for 1:1 or Free multi-component systems.)
- Settings using SW1 are given below.
- Please set the mutually different address, and prevent the start up simultaneously. (In case of connecting with PEH-P16, 20)

## 10. Test run

### 10.1. Test run

The test run can be carried out either from the outdoor unit or the indoor unit.

#### 1. Checklist

- After the installation, piping setup, and wiring of the indoor and outdoor units is complete, check that refrigerant is not leaking, the power and control wires are not loose, and the poles are not reversed. (When connecting model PEH-P-MYA in particular, check that there is current in the separate power supply cable for the indoor unit.)
- Use a 500 V insulation resistance tester to make sure that the resistance between the power terminal and the ground is 1.0 MΩ or more. If it is less than 1.0 MΩ, do not operate the unit. \* Absolutely do not touch the tester to indoor/outdoor connection terminals S1, S2, and S3. An accident could occur.
- Make sure there is no malfunction in the outdoor unit. (If there is a malfunction, you can diagnose it using LED2 on the board.)
- Check that the ball valve is fully open on both the liquid and gas ends.
- Check the electrical power phase. If the phase is reversed, the fan may rotate in the wrong direction or stop, or unusual sounds may be produced.
- Starting at least 12 hours before the test run, send current through the crankcase heater. (If the current is running for a shorter period of time, damage to the compressor could result.)

After the above checks are complete, carry out the test run as indicated in the following outline.

### 10.2. How to handle problems with the test run

#### Error code list: details

Error details	Problem location	MELANS display	Remote controller display
Remote controller communication – reception error	Remote Controller	6831,6834	E0
Remote controller communication – transmission error	Remote Controller	6832,6833	E3
Remote controller communication – reception error	Indoor unit	6831,6834	E4
Remote controller communication – transmission error	Indoor unit	6832,6833	E5
Communication between indoor and outdoor units – reception error	Indoor unit	6740,6843	E6
Communication between indoor and outdoor units – transmission error	Indoor unit	6841,6842	E7
Communication between indoor and outdoor units – reception error	Outdoor unit	6840,6843	E8
Communication between indoor and outdoor units – transmission error	Outdoor unit	6841,6842	E9
Indoor/outdoor connection wiring error, indoor unit overload (5 units or more)	Outdoor unit	6844	EA
Indoor/outdoor connection wiring error (interference, loose)	Outdoor unit	6845	EB
Excessive time in use	Outdoor unit	6846	EC
Serial communication error	Outdoor unit	0403	ED
Serial communication error	M-NET board	0403	EE

### (SW1)

SW1 function switching	Model	Operation by switch manipulation	
		ON	OFF
1	–	–	–
2	Error history clear	Clear	Ordinary
3	Refrigerant system address setting	Outdoor unit address Settings 0 - 15	
4	↑		
5	↑		
6	↑		

[Fig. 9.3.1] (P.5)

## 9.4. Location of wiring connections

- Using the conduit mounting plates  
Conduit mounting plates are supplied in three sizes (ø27, ø34, ø40). Choose the size of mounting plate that matches the outer diameter of the conduit being used.

[Fig. 9.4.1] (P.5)

- Ⓐ When installing conduit from bottom panel
- Ⓑ When installing conduit from front panel
- Ⓒ Mounting plate (attached)
- Ⓓ Knock-out hole

#### 2. Starting and finishing the test run

- Procedure from the indoor unit: carry out the test run as in the manual provided with the indoor unit.
- Procedure from the outdoor unit: start and stop the test run and set test run mode (cooling/heating) using the SW4 dip switches on the board.
  - ① Set test run mode (cooling/heating) using SW 4-2.
  - ② The test run will begin when SW 4-1 is turned ON, according to the mode selected by SW 4-2.
  - ③ The test run is stopped when SW 4-1 is turned OFF.



#### Note:

**Test run mode cannot be stopped during operation by using SW 4-2. (If the operation mode is to be changed, first stop it using SW 4-1, then after changing the operation mode, start the test run again using SW 4-1.)**

- If the 2-hour timer is set, the test run will stop automatically after 2 hours.
- During the test run, the room temperature display on the indoor unit will indicate the temperature of the indoor unit piping.
- When you operate the test run from OC1, all trial runs are completed by OC1 → IC1 → MA → IC1 → OC2.

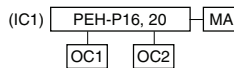

Error details	Problem location	MELANS display	Remote controller display
Reverse phase, out of phase verification	Outdoor unit	4103	F1
Faulty input circuit	Outdoor unit	4115	F8
Duplicated M-NET address setting	M-NET board	6600	A0
M-NET error in PH/W transmission	M-NET board	6602	A2
M-NET bus busy	M-NET board	6603	A3
M-NET communication error with P transmission	M-NET board	6606	A6
M-NET error – no ACK	M-NET board	6607	A7
M-NET error- no response	M-NET board	6608	A8
Undefined error code	–	undefined	EF
Outlet temperature error	Outdoor unit	1102	U2
CN23 Short-circuit Connector Unplugged	Outdoor unit	1108	U2
Open/short in discharge temp thermistor	Outdoor unit	5104	U3
Open/short in liquid temp or condenser/evaporater temp thermistor	Outdoor unit	5105	U4
Compressor overcurrent interruption (51C operation)	Outdoor unit	4101	U6
High pressure error (63H1 operation)	Outdoor unit	1302	UE
Low pressure error (63L operation)	Outdoor unit	1300	UL
Power synchronous idle circuit error	Outdoor unit	4115	F8
Inlet sensor error	Indoor unit	5101	P1
Piping sensor error	Indoor unit	5102	P2
Drain sensor error	Indoor unit	2503	P4
Drain overflow protector operation	Indoor unit	2502	P5
Water leak error (PDH only)	Indoor unit	2500	P5
Freeze prevention operation	Indoor unit	1503	P6
Surge prevention operation	Indoor unit	1504	P6
Piping temperature error	Indoor unit	1110	P8

- Depending on the position of the SW2 switch on the outdoor unit board, the segments light up to indicate the running condition of the unit and the particulars of the check code.

SW2 setting 123456	Item	Display contents																														
000000	Operation mode/relay output	tens place O: stop C: cooling H: heating d: defrosting  units place 1: SV1 2: 21S4 4: 52C	Relay output = SV1 + 21S4 + 52C  Ex. During cooling mode, when 52C and SV1 are ON: C5  When an error occurs, the error code and error signal (*1) are displayed in alternation.																													
011110	Outdoor unit control condition	Control mode display system																														
010110	Indoor unit control condition (IC1) (IC2)																															
110110	Indoor unit control condition (IC3) (IC4)	Indoor unit No.2 Indoor unit No.4	Indoor unit No.1 Indoor unit No.3 Outdoor unit																													
		<table border="1"> <thead> <tr> <th rowspan="2">Display</th> <th colspan="2">Control mode</th> </tr> <tr> <th>Indoor unit</th> <th>Outdoor unit</th> </tr> </thead> <tbody> <tr><td>0</td><td>Ordinary</td><td>←</td></tr> <tr><td>1</td><td>Hot adjustment</td><td>←</td></tr> <tr><td>2</td><td>Defrosting</td><td>←</td></tr> <tr><td>3</td><td>—</td><td>←</td></tr> <tr><td>4</td><td>Heater ON</td><td>←</td></tr> <tr><td>5</td><td>Freeze prevention</td><td>←</td></tr> <tr><td>6</td><td>Surge prevention</td><td>←</td></tr> <tr><td>7</td><td>Compressor OFF</td><td>←</td></tr> </tbody> </table>		Display	Control mode		Indoor unit	Outdoor unit	0	Ordinary	←	1	Hot adjustment	←	2	Defrosting	←	3	—	←	4	Heater ON	←	5	Freeze prevention	←	6	Surge prevention	←	7	Compressor OFF	←
Display	Control mode																															
	Indoor unit	Outdoor unit																														
0	Ordinary	←																														
1	Hot adjustment	←																														
2	Defrosting	←																														
3	—	←																														
4	Heater ON	←																														
5	Freeze prevention	←																														
6	Surge prevention	←																														
7	Compressor OFF	←																														
011100	Error code history 1	The error code (ex. U8, UA) and error indicator (*1) are displayed in alternation.																														
111100	Error code history 2																															

\*1 Display system for error indicator  
 The indicator corresponds to the following numbers  
 0 ..... Outdoor unit  
 1 ..... Indoor unit No.1  
 2 ..... Indoor unit No.2  
 3 ..... Indoor unit No.3  
 4 ..... Indoor unit No.4

### 10.3. The following occurrences are not problems or errors

Problem	Remote controller display	Cause
The auto vane moves on its own.	Ordinary display	As a result of the auto vane control operations, during cooling, when downward blowing has been used, after 1 hour has passed horizontal blowing sometimes occurs automatically. During defrosting in heating, hot adjustment, and thermostat OFF modes, horizontal blowing occurs automatically.
The fan setting changes during heating.	Ordinary display	During thermostat OFF mode, light air or low air operation will take place. During thermostat ON mode, light air or low air will switch automatically to set notch on the basis of time or piping temperature.
The fan stops during heating.	Defrosting display	During defrosting, the fan will stop.
Although operation has stopped, the fan does not stop.	Off	When the supplementary electric heater is ON, the fan will run for 1 minute after operation stops in order to expel excess hot air (during heating only).
When the switch is turned ON, the fan does not begin to operate.	Heating preparations underway	After the switch is turned to ON or until the piping temperature reaches 35°C, there will be 5 minutes of light air operation. After that there will be 2 minutes of low air operation, then set notch will begin (hot adjustment control).
The outdoor unit fan turns in reverse or stops, and an unusual sound is heard.	Ordinary display	There is a risk of the power to the outdoor unit being connected in reverse phase. Be sure to check that the phase is correct.







---

This product is designed and intended for use in the residential, commercial and light-industrial environment.

The product at hand is based on the following EU regulations:

- Low Voltage Directive 73/23/EEC
- Electromagnetic Compatibility Directive 89/336/EEC

Please be sure to put the contact address/telephone number on this manual before handing it to the customer.