

# Air-Conditioners

## PEAD-RP·EA

### INSTALLATION MANUAL

For safe and correct use, please read this installation manual thoroughly before installing the air-conditioner unit.  
How to install outdoor units and items about the multi-unit system are described in the outdoor unit installation manual.  
\* Remote controller is available as an optional remote controller.

### INSTALLATIONSHANDBUCH

Zum sicheren und ordnungsgemäßen Gebrauch der Klimaanlage das Installationshandbuch gründlich durchlesen.

### MANUEL D'INSTALLATION

Veuillez lire le manuel d'installation en entier avant d'installer ce climatiseur pour éviter tout accident et vous assurer d'une utilisation correcte.

### INSTALLATIEHANDLEIDING

Voor een veilig en juist gebruik moet u deze installatiehandleiding grondig doorlezen voordat u de airconditioner installeert.

### MANUAL DE INSTALACIÓN

Para un uso seguro y correcto, lea detalladamente este manual de instalación antes de montar la unidad de aire acondicionado.

### MANUALE DI INSTALLAZIONE

Per un uso sicuro e corretto, leggere attentamente questo manuale di installazione prima di installare il condizionatore d'aria.

### ΕΓΧΕΙΡΙΔΙΟ ΟΔΗΓΙΩΝ ΕΓΚΑΤΑΣΤΑΣΗΣ

Για ασφάλεια και σωστή χρήση, παρακαλείστε διαβάσετε προσεχτικά αυτό το εγχειρίδιο εγκατάστασης πριν αρχίσετε την εγκατάσταση της μονάδας κλιματισμού.

### MANUAL DE INSTALAÇÃO

Para segurança e utilização correctas, leia atentamente este manual de instalação antes de instalar a unidade de ar condicionado.

### INSTALLATIONSMANUAL

Læs venligst denne installationsmanual grundigt, før De installerer airconditionanlægget, af hensyn til sikker og korrekt anvendelse.

### INSTALLATIONSMANUAL

Läs denna installationsmanual noga för säkert och korrekt bruk innan luftkonditioneringen installeras.

### MONTAJ ELKİTABI

Emniyetli ve doğru biçimde nasıl kullanılacağını öğrenmek için lütfen klima cihazını monte etmeden önce bu elkitabını dikkatle okuyunuz.

### РУКОВОДСТВО ПО УСТАНОВКЕ

Для осторожного и правильного использования прибора необходимо тщательно ознакомиться с данным руководством по установке до выполнения установки кондиционера.

English

Deutsch

Français

Nederlands

Español

Italiano

Ελληνικά

Português

Dansk

Svenska

Türkçe

Русский

2

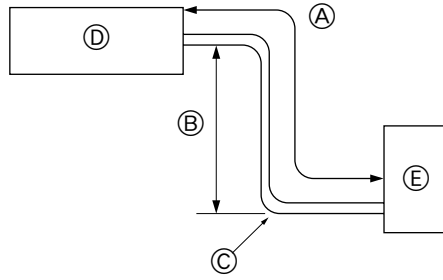

Fig. 2-1

3

(mm)

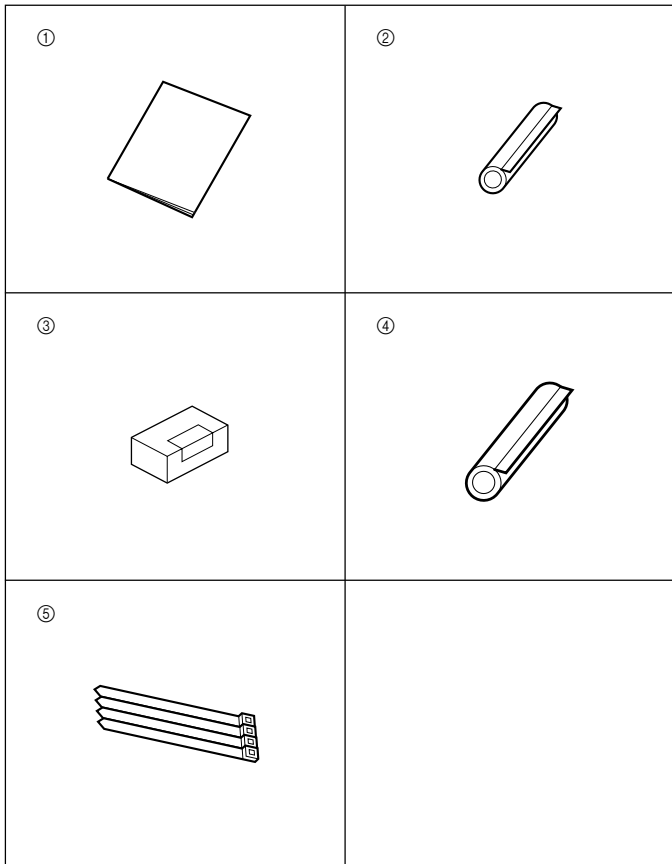

Fig. 3-1

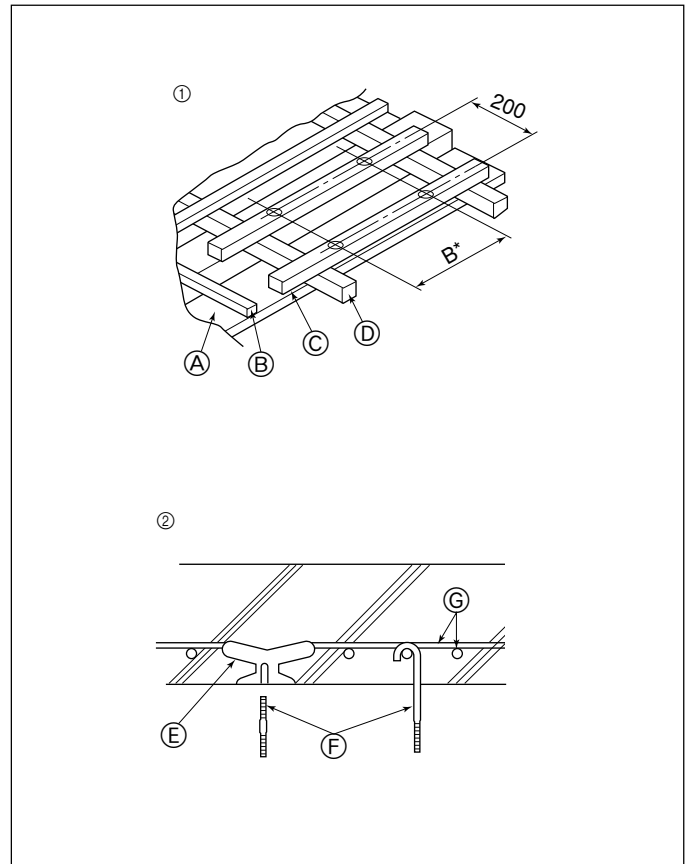

Fig. 3-2

4

(mm)

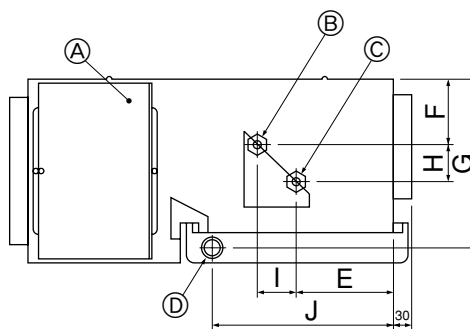

Fig. 4-1

2

5

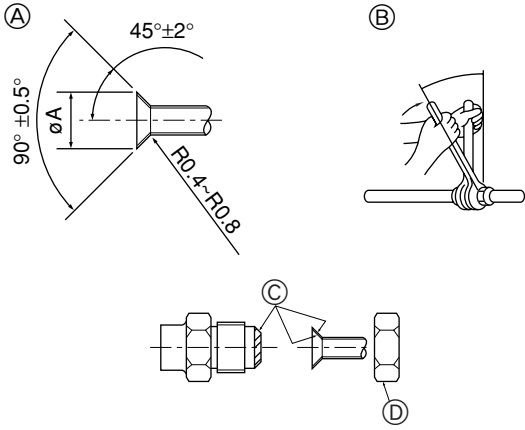

Fig. 5-1

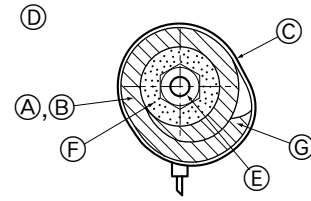

Fig. 5-2

6

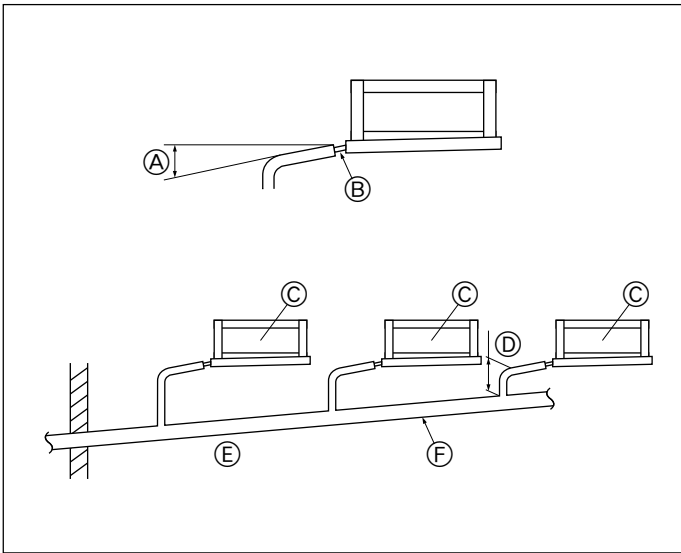

Fig. 6-1

7

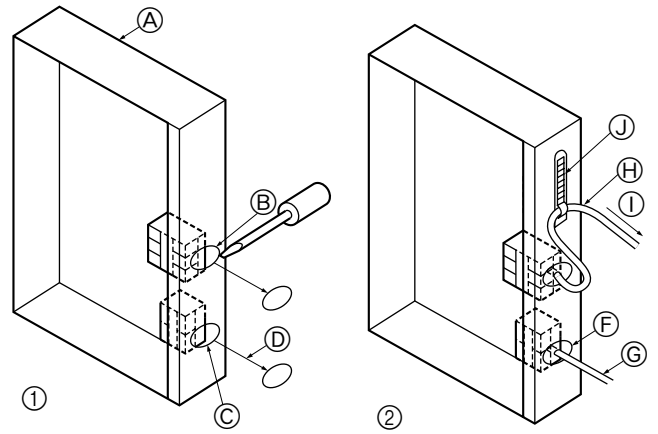

Fig. 7-1

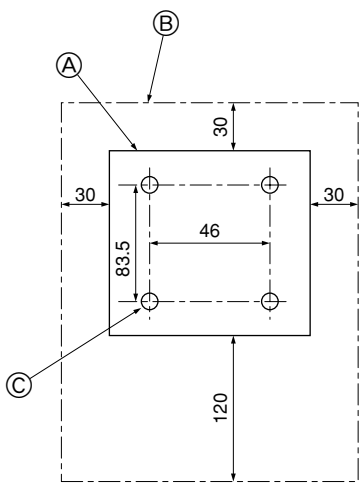

Fig. 7-2

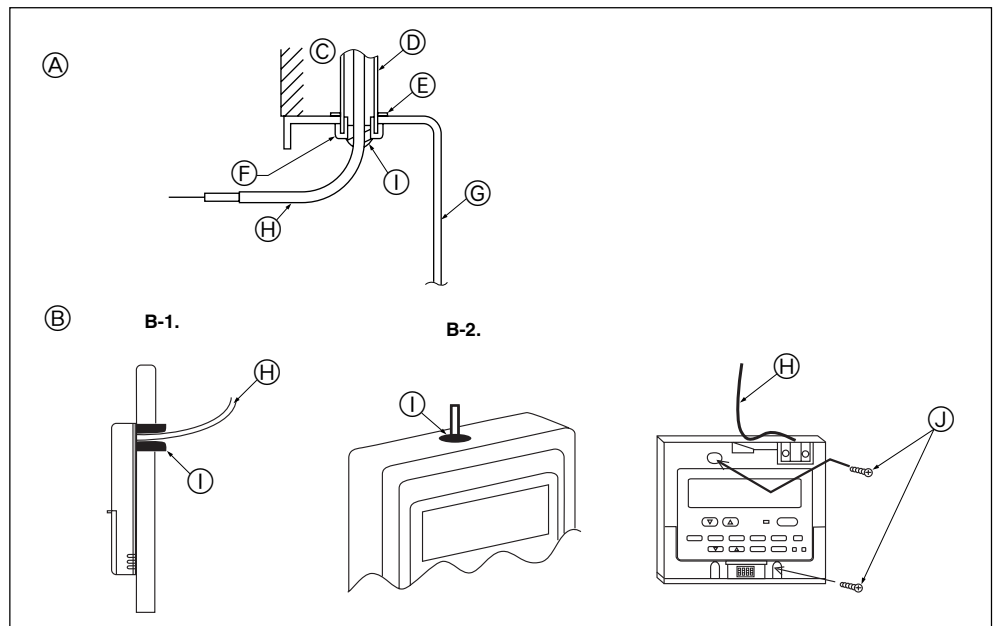

Fig. 7-3

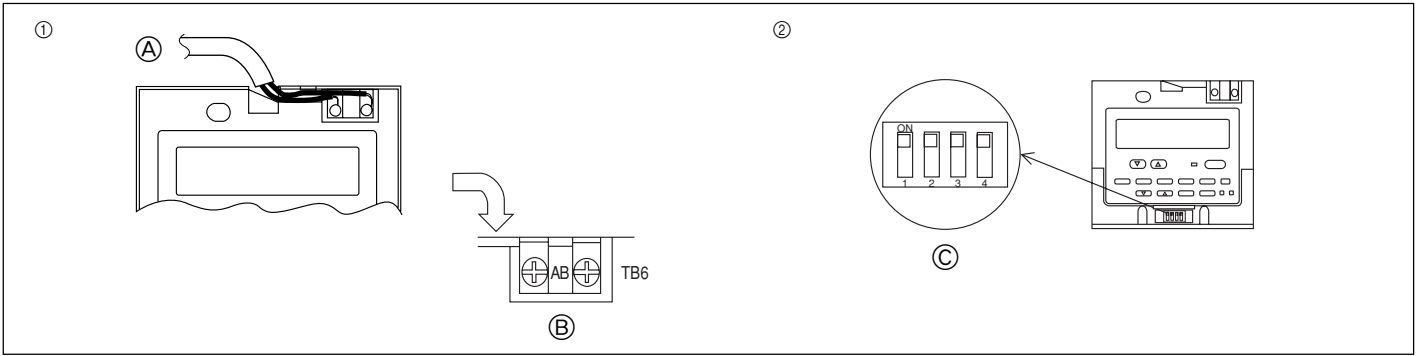

Fig. 7-4

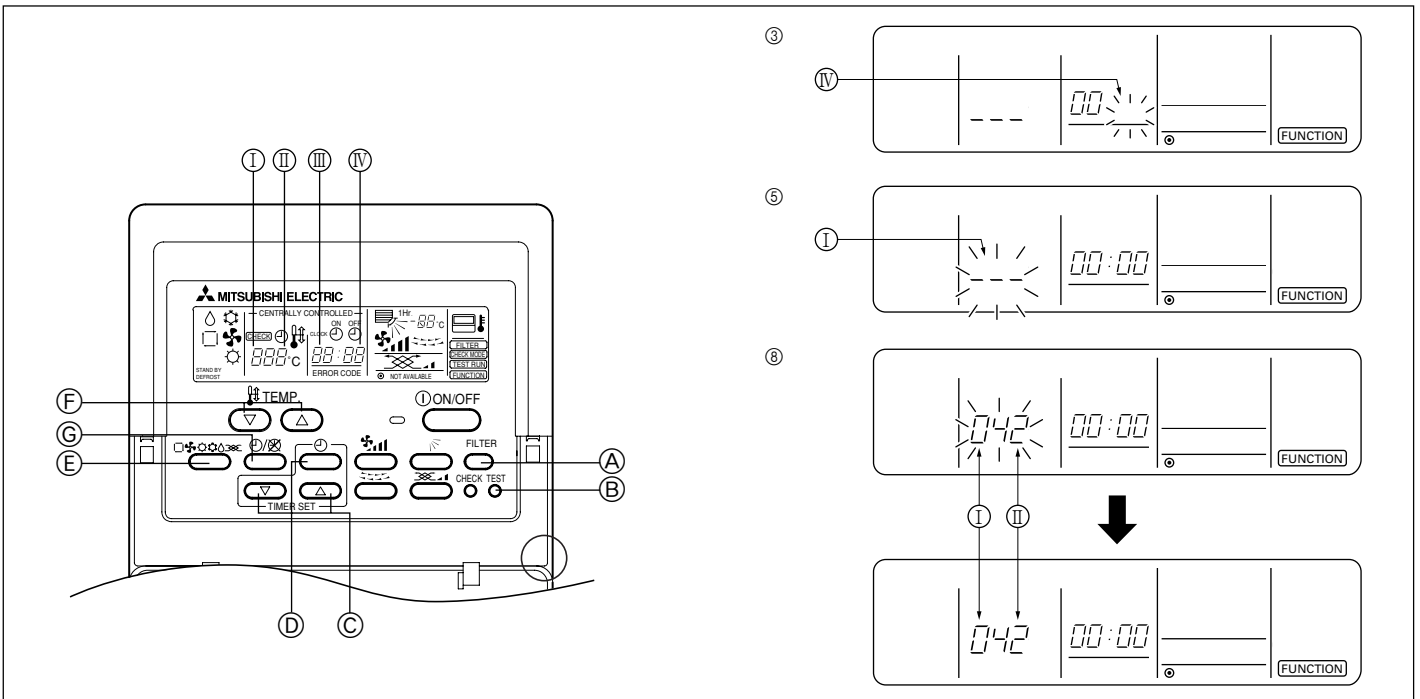
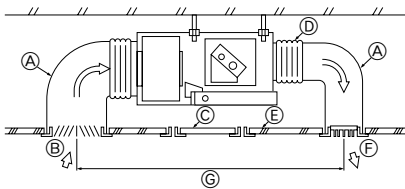
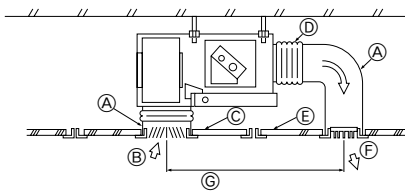

Fig. 7-5



<A> In case of rear inlet



<B> In case of bottom inlet

Fig. 8-1

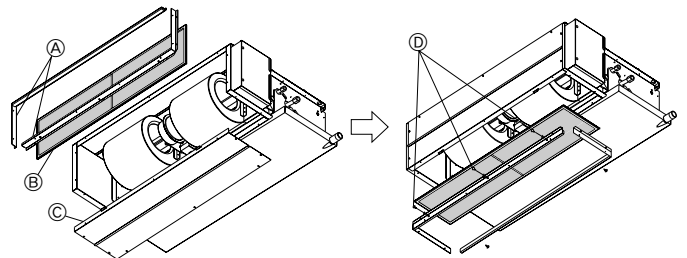

Fig. 8-2

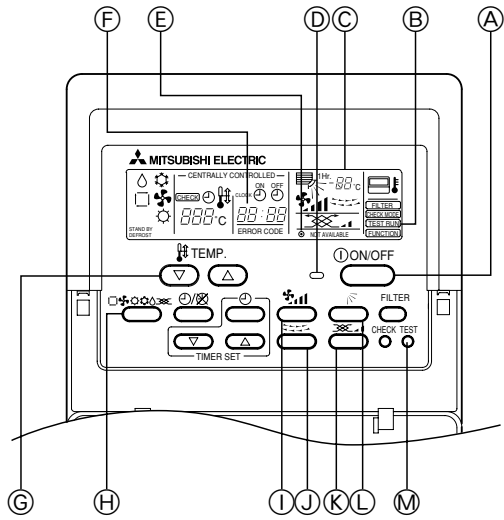

Fig. 9-1

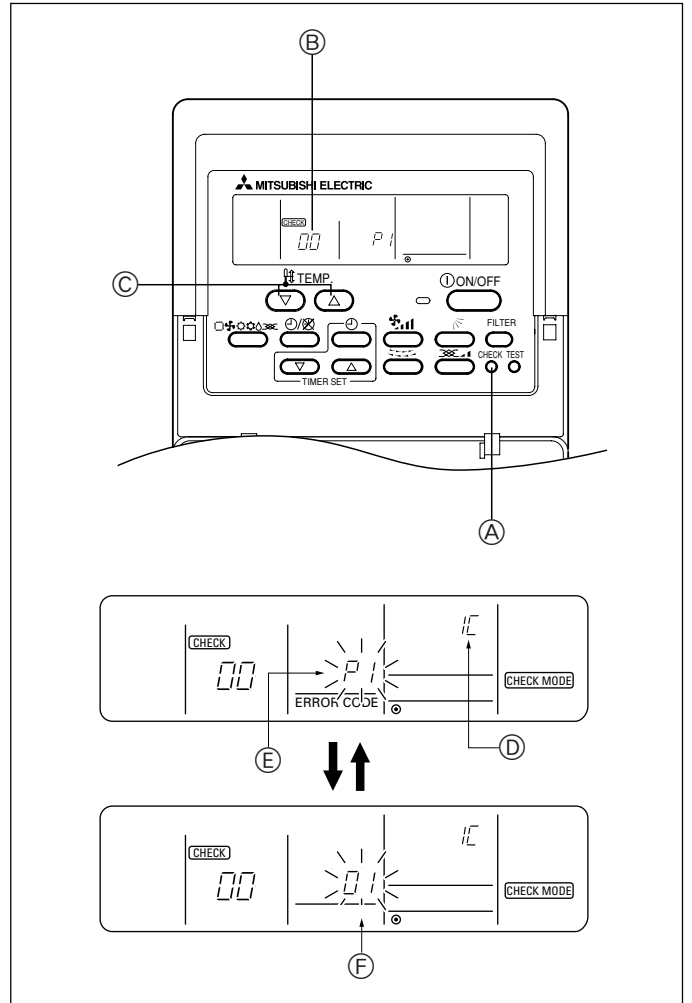

Fig. 9-2

# Contents

## 1. Safety precautions

1. Safety precautions .....	6
2. Installation location .....	6
3. Installing the indoor unit .....	7
4. Installing the pipes .....	7
5. Refrigerant piping work .....	7
6. Drainage piping work .....	7
7. Electrical work .....	8
8. Duct work .....	10
9. Test run .....	10
10. System control .....	11

- ▶ Before installing the unit, make sure you read all the "Safety precautions".
- ▶ Please report to or take consent by the supply authority before connection to the system.

### ⚠ Warning:

Describes precautions that must be observed to prevent danger of injury or death to the user.

### ⚠ Caution:

Describes precautions that must be observed to prevent damage to the unit.

After installation work has been completed, explain the "Safety Precautions," use, and maintenance of the unit to the customer according to the information in the Operation Manual and perform the test run to ensure normal operation. Both the Installation Manual and Operation Manual must be given to the user for keeping. These manuals must be passed on to subsequent users.

⊘ : Indicates an action that must be avoided.

❗ : Indicates that important instructions must be followed.

⚡ : Indicates a part which must be grounded.

⚠ : Indicates that caution should be taken with rotating parts.

⚠ : Beware of electric shock.

### ⚠ Warning:

Carefully read the labels affixed to the main unit.

### ⚠ Warning:

- Ask a dealer or an authorized technician to install the unit.
- For installation work, follow the instructions in the Installation Manual and use tools and pipe components specifically made for use with refrigerant specified in the outdoor unit installation manual.
- The unit must be securely installed on a structure that can sustain its weight.
- If the air conditioner is installed in a small room, measures must be taken to prevent the refrigerant concentration in the room from exceeding the safety limit in the event of refrigerant leakage. Should the refrigerant leak and cause the concentration limit to be exceeded, hazards due to lack of oxygen in the room may result.
- Ventilate the room if refrigerant leaks during operation. If refrigerant comes into contact with a flame, poisonous gases will be released.
- All electric work must be performed by a qualified technician according to local regulations and the instructions given in this manual.
- Use only specified cables for wiring.
- The terminal block cover of the unit must be firmly attached.
- Use only accessories authorized by Mitsubishi Electric and ask a dealer or an authorized technician to install them.
- The user should never attempt to repair the unit or transfer it to another location.
- After installation has been completed, check for refrigerant leaks. If refrigerant leaks into the room and comes into contact with the flame of a heater or portable cooking range, poisonous gases will be released.
- Do not turn on the power until installation has been completed.

### 1.1. Before installation (Environment)

#### ⚠ Caution:

- Do not use the unit in an unusual environment. If the air conditioner is installed in areas exposed to steam, volatile oil (including machine oil), or sulfuric gas, areas exposed to high salt content such as the seaside, the performance can be significantly reduced and the internal parts can be damaged.
- Do not install the unit where combustible gases may leak, be produced, flow, or accumulate. If combustible gas accumulates around the unit, fire or explosion may result.

## 2. Installation location

- Do not keep food, plants, caged pets, artwork, or precision instruments in the direct airflow of the indoor unit or too close to the unit, as these items can be damaged by temperature changes or dripping water.
- When the room humidity exceeds 80% or when the drainpipe is clogged, water may drip from the indoor unit. Do not install the indoor unit where such dripping can cause damage.
- When installing the unit in a hospital or communications office, be prepared for noise and electronic interference. Inverters, home appliances, high-frequency medical equipment, and radio communications equipment can cause the air conditioner to malfunction or breakdown. The air conditioner may also affect medical equipment, disturbing medical care, and communications equipment, harming the screen display quality.

### 1.2. Before installation or relocation

#### ⚠ Caution:

- Be extremely careful when transporting the units. Two or more persons are needed to handle the unit, as it weighs 20 kg or more. Do not grasp the packaging bands. Wear protective gloves, as you can injure your hands on the fins or other parts.
- Be sure to safely dispose of the packaging materials. Packaging materials, such as nails and other metal or wooden parts may cause stabs or other injuries.
- Thermal insulation of the refrigerant pipe is necessary to prevent condensation. If the refrigerant pipe is not properly insulated, condensation will be formed.
- Place thermal insulation on the pipes to prevent condensation. If the drainpipe is installed incorrectly, water leakage and damage to the ceiling, floor, furniture, or other possessions may result.
- Do not clean the air conditioner unit with water. Electric shock may result.
- Tighten all flare nuts to specification using a torque wrench. If tightened too much, the flare nut can break after an extended period.

### 1.3. Before electric work

#### ⚠ Caution:

- Be sure to install circuit breakers. If not installed, electric shock may result.
- For the power lines, use standard cables of sufficient capacity. Otherwise, a short circuit, overheating, or fire may result.
- When installing the power lines, do not apply tension to the cables.
- Be sure to ground the unit. If the unit is not properly grounded, electric shock may result.
- Use circuit breakers (ground fault interrupter, isolating switch (+B fuse), and molded case circuit breaker) with the specified capacity. If the circuit breaker capacity is larger than the specified capacity, breakdown or fire may result.

### 1.4. Before starting the test run

#### ⚠ Caution:

- Turn on the main power switch more than 12 hours before starting operation. Starting operation just after turning on the power switch can severely damage the internal parts.
- Before starting operation, check that all panels, guards and other protective parts are correctly installed. Rotating, hot, or high voltage parts can cause injuries.
- Do not operate the air conditioner without the air filter set in place. If the air filter is not installed, dust may accumulate and breakdown may result.
- Do not touch any switch with wet hands. Electric shock may result.
- Do not touch the refrigerant pipes with bare hands during operation.
- After stopping operation, be sure to wait at least five minutes before turning off the main power switch. Otherwise, water leakage or breakdown may result.

### 2.1. Refrigerant pipe (Fig. 2-1)

- Refer to the outdoor unit installation manual.

- Ⓐ Pipe length
- Ⓑ Height
- Ⓒ Number of bends (one way)
- Ⓓ Indoor unit
- Ⓔ Outdoor unit

### 3. Installing the indoor unit

#### 4. Installing the pipes

#### 3.1. Check the indoor unit accessories (Fig. 3-1)

The indoor unit should be supplied with the following accessories.

	Accessory name	Q'ty
①	Piping instruction	1pc.
②	Insulation pipe	1pc.
③	Remote controller parts	1pc.
④	Insulation pipe	1pc.
⑤	Band	4pcs.

#### 3.2. Suspension bolt installation (Give site of suspension strong structure) (Fig. 3-2)

##### ① Wooden structure

- Select tie beam (one-story houses) or second-floor girder (two-story houses) as reinforcement member.
- Use sturdy beams of at least 6cm square for beam pitch of 90cm or less or of at least 9cm square for beam pitch of 90-180cm.

Ⓐ Ceiling      Ⓑ Rafter      Ⓒ Beam      Ⓓ Roof beam

##### ② Ferro-concrete structures

Secure the suspension bolts using the method shown, or use steel or wooden hangers, etc. to install the suspension bolts.

- Ⓔ Use inserts rated at 100-150 kg each (procure locally)
- Ⓕ Suspension bolts M10 (3/8") (procure locally)
- Ⓖ Steel reinforcing rod

##### Installing the suspension bolts

- Check the pitch of the suspension bolts.
- Use the  $\phi 10$  (3/8") suspension bolts (x4, obtain locally).
- Adhere strictly to the length of the suspension bolts (specified figure below).

#### 3.3. Carry-in/Installation of indoor unit

- Carry in indoor unit to the installation site without unpacking.
- Install indoor unit before mounting ceiling surface material.
- Lift unit body with a lifting machine, and suspend it through suspension bolt.
- Be sure to install indoor unit horizontally. Installing it in slant may cause drain water leak.
- Check unit for horizontal installation with a level gauge, and if slanted, re-adjust it by loosening the nut holding suspension fixtures.

#### 4.1. Refrigerant and drainage piping locations of indoor unit

1. For the limitation of piping length and the allowable height difference, refer to the instruction manual of outdoor unit.
2. The connection method of piping is of flare connection. (Fig. 4-1)

- Ⓐ Electrical parts box
- Ⓑ Refrigerant piping (liquid)
- Ⓒ Refrigerant piping (gas)
- Ⓓ Drain piping

	E	F	G	H	I	J
RP3, 4, 5, 6	169	122	308	46	53	323

### 5. Refrigerant piping work

#### 6. Drainage piping work

#### 5.1. Refrigerant and drainage piping connection (Fig. 5-1)

- When commercially available copper pipes are used, wrap liquid and gas pipes with commercially available insulation materials (heat-resistant to 100 °C or more, thickness of 12 mm or more).
- The indoor parts of the drain pipe should be wrapped with polyethylene foam insulation materials (specific gravity of 0.03, thickness of 9 mm or more).
- Apply thin layer of refrigerant oil to pipe and joint seating surface before tightening flare nut.
- Use torque wrench and spanner to tighten piping connections.
- Use refrigerant piping insulation provided to insulate indoor unit connections. Insulate carefully.

##### Ⓐ Flare cutting dimensions

Copper pipe O.D. (mm)	Flare dimensions $\phi A$ dimensions (mm)
$\phi 6.35$	8.7 - 9.1
$\phi 9.52$	12.8 - 13.2
$\phi 12.7$	16.2 - 16.6
$\phi 15.88$	19.3 - 19.7

##### Ⓑ Flare nut tightening torque

Copper pipe O.D. (mm)	Flare nut O.D. (mm)	Tightening torque (N·m)
$\phi 6.35$	17	14 - 18
$\phi 9.52$	22	34 - 42
$\phi 12.7$	26	49 - 61
$\phi 15.88$	29	68 - 82
$\phi 15.88$	36	100 - 120

##### Ⓒ Apply refrigerating machine oil over the entire flare seat surface.

##### Ⓓ Use the flare nuts as follows.

	RP3	RP4-6
Indoor unit (Liquid)	Flare nut attached to indoor liquid valve	Flare nut attached to indoor liquid valve
Indoor unit (Gas)	Flare nut attached to indoor gas valve	* Flare nut in outdoor unit accessories
Outdoor unit (Liquid)	Flare nut attached to outdoor liquid valve	Flare nut attached to outdoor liquid valve
Outdoor unit (Gas)	Flare nut attached to outdoor gas valve	Flare nut attached to outdoor gas valve

\* If the flare nut attached to indoor gas valve is used, gas leakage or even pipe extraction will occur.

#### 5.2. Indoor unit (Fig. 5-2)

##### Heat insulation for refrigerant pipes:

- ① Wrap the large pipe cover around the gas pipe, making sure that the end of the pipe cover touches the side of the unit.
- ② Wrap the small pipe cover around the liquid pipe, making sure that the end of the pipe cover touches the side of the unit.
- ③ Secure both ends of each pipe cover with the enclosed bands. (Attach the bands 20 mm from the ends of the pipe cover.)

- Ⓐ Pipe cover (large)
- Ⓑ Pipe cover (small)
- Ⓒ Band
- Ⓓ Cross-sectional view of connection
- Ⓔ Pipe
- Ⓕ Insulating material
- Ⓖ Squeeze

- After connecting the refrigerant piping to the indoor unit, be sure to test the pipe connections for gas leakage with nitrogen gas. (Check that there is no leakage from the refrigerant piping to the indoor unit.)

#### 5.3. For twin/triple combination

Refer to the outdoor unit installation manual.

#### 6.1. Drainage piping work (Fig. 6-1)

1. For drain piping, provide a downward slope of 1/100 or more to the water outlet and do not provide any trap or rising section on the way.
2. Keep the horizontal length of drain piping less than 20 m (not including the height difference).  
For long drain piping, provide a metal support, fixture on the way to eliminate the waving of the piping. Never install an air vent pipe. Otherwise, drain may blow out.
3. For drain piping, use the PVC pipe VP-25 (outside diameter  $\phi 32$ ).
4. For collective drain piping, arrange the piping to 10 cm lower than the unit drain outlet.

## 6. Drainage piping work

## 7. Electrical work

5. Insulate the drain pipe with insulating material as 5.1.
6. Locate the outlet of drain piping so that it will not generate odor.
7. Do not connect drain piping directly to sewer system as this may generate sulfur gas.
  - Ⓐ Downward slope 1/100 or more
  - Ⓑ Connection dia 25A external thread
  - Ⓒ Indoor unit
  - Ⓓ Maximize this length to approx. 10 cm
  - Ⓔ Collective piping
  - Ⓕ Downward slope 1/100 or more

### 7.1. Indoor unit (Fig. 7-1)

#### Field wiring method

##### ① Open knockout holes.

(Recommend to use a screwdriver or the like for this work.)

- |                 |                 |
|-----------------|-----------------|
| Ⓐ Control box   | Ⓒ Knockout hole |
| Ⓑ Knockout hole | Ⓓ Remove        |

##### ② Fix power source wiring to control box by using buffer bushing for tensile force. (PG connection or the like.) Secure the wiring Ⓓ with the tie wrap ①. Connect transmission wiring to transmission terminal block through the knockout hole of control box using ordinary bushing.

- Ⓔ To prevent external tensile force from applying to the wiring connection section of power source terminal block use buffer bushing like PG connection or the like.
- Ⓕ Use ordinary bushing
- Ⓖ Remote controller
- Ⓖ Indoor/Outdoor unit connecting wiring
- ① Tensile force
- ① Tie wrap

- ▶ Selecting non-fuse breaker (NF) or earth leakage breaker (NV).
- ▶ Always install an earth. (Earth cable dia: Thicker than 1.6 mm)

### 7.2. Remote controller

#### 7.2.1. For wired remote controller

##### 1) Installing procedures

- (1) Select an installing position for the remote controller. (Fig. 7-2)
- The temperature sensors are located on both remote controller and indoor unit.

##### ▶ Procure the following parts locally:

- Two piece switch box
- Conduit tube
- Lock nuts and bushings

##### ▶ Remote controller guide

- Ⓐ Remote controller profile
  - Ⓑ Required clearances surrounding the remote controller
  - Ⓒ Installation pitch
- (2) Seal the service entrance for the remote controller cord with putty to prevent possible invasion of dew drops, water, cockroaches or worms. (Fig. 7-3)
    - Ⓐ For installation in the switch box:
    - Ⓑ For direct installation on the wall select one of the following:
      - Prepare a hole through the wall to pass the remote controller cord (in order to run the remote controller cord from the back), then seal the hole with putty.
      - Run the remote controller cord through the cut-out at top of case, then seal the cut-out notch with putty similarly as above.

##### B-1. Route of cord to back of controller:

##### B-2. Route of cord to top of controller:

- (3) For direct installation on the wall

- Ⓒ Wall
- Ⓓ Conduit
- Ⓔ Lock nut
- Ⓕ Bushing
- Ⓖ Switch box
- Ⓖ Remote controller cord
- ① Seal with putty
- ① Wood screw

##### 2) Connecting procedures (Fig. 7-4)

- ① Connect the remote controller cord to the terminal block.
  - Ⓐ To TB5 on the indoor unit
  - Ⓑ TB6 (No polarity)
- ② Set the dip switch No.1 shown Ⓒ when using two remote controller's for the same group.
  - Ⓒ Dip switches

#### Setting the dip switches

The dip switches are at the bottom of the remote controller. Remote controller Main/Sub and other function settings are performed using these switches. Ordinarily, only change the Main/Sub setting of SW No.1. (The factory settings are all "ON".)

##### <SW No. 1>

SW contents Main	Remote controller Main/Sub setting
ON/OFF	Main/Sub
Comment	Set one of the two remote controllers at one group to "Main"

##### <SW No. 2>

SW contents Main	When remote controller power turned on
ON/OFF	Normally on/Timer mode on
Comment	When you want to return to the timer mode when the power is restored after a power failure when a Program timer is connected, select "Timer mode".

##### <SW No. 3>

SW contents Main	Cooling/heating display in AUTO mode
ON/OFF	Yes/No
Comment	When you do not want to display "Cooling" and "Heating" in the Auto mode, set to "No".

##### <SW No. 4>

SW contents Main	Intake temperature display
ON/OFF	Yes/No
Comment	When you do not want to display the intake temperature, set to "No".

### 7.3. Function settings

#### 7.3.1. For wired remote controller (Fig. 7-5)

- ① Mode number
- ② Setting number
- ③ Refrigerant address
- ④ Unit number

##### Changing the power voltage setting

- Be sure to change the power voltage setting depending on the voltage used.

- ① Go to the function setting mode.
    - Switch OFF the remote controller.
    - Press the Ⓐ and Ⓑ buttons simultaneously and hold them for at least 2 seconds. FUNCTION will start to flash.
  - ② Use the Ⓒ button to set the refrigerant address (Ⅲ) to 00.
  - ③ Press Ⓓ and [-] will start to flash in the unit number (Ⅳ) display.
  - ④ Use the Ⓒ button to set the unit number (Ⅳ) to 00.
  - ⑤ Press the Ⓔ MODE button to designate the refrigerant address/unit number. [-] will flash in the mode number (Ⅰ) display momentarily.
  - ⑥ Press the Ⓕ buttons to set the mode number (Ⅰ) to 04.
  - ⑦ Press the Ⓖ button and the current set setting number (Ⅱ) will flash.
    - Use the Ⓕ button to switch the setting number to the power supply voltage to be used.
- Power supply voltage
- |              |   |                    |
|--------------|---|--------------------|
| 240 V        | : | setting number = 1 |
| 220 V, 230 V | : | setting number = 2 |
- ⑧ Press the MODE button Ⓔ and the setting number (Ⅰ) and (Ⅱ) will change to being on constantly and the contents of the setting can be confirmed.
  - ⑨ Press the FILTER Ⓐ and TEST RUN Ⓑ buttons simultaneously for at least two seconds. The function selection screen will disappear momentarily and the air conditioner OFF display will appear.



## 7. Electrical work

### Function table

Select unit number 00

Mode	Settings	Mode no.	Setting no.	Initial setting	Setting
Power failure automatic recovery	Not available	01	1	○	
	Available		2		
Indoor temperature detecting	Indoor unit operating average	02	1	○	
	Set by indoor unit's remote controller		2		
	Remote controller's internal sensor		3		
LOSSNAY connectivity	Not Supported	03	1		
	Supported (indoor unit is not equipped with outdoor-air intake)		2		
	Supported (indoor unit is equipped with outdoor-air intake)		3		
Power voltage	240 V	04	1		
	220 V, 230 V		2	○	
Auto mode	Energy saving cycle automatically enabled	05	1	○	
	Energy saving cycle automatically disabled		2		

Select unit numbers 01 to 03 or all units (AL [wired remote controller]/07 [wireless remote controller])

Mode	Settings	Mode no.	Setting no.	Initial setting	Setting
Filter sign	100Hr	07	1		
	2500Hr		2		
	No filter sign indicator		3	○	
Fan speed	Standard (PLH/PLA-P-AA(H)/PLA-RP-AA)/Silent (PLH/PLA-P-KA(H), PCH/PCA)	08	1		
	High ceiling ① (PLH/PLA-P-AA(H)/PLA-RP-AA)/Standard (PLH/PLA-P-KA(H), PCH/PCA)		2	–	
	High ceiling ② (PLH/PLA-P-AA(H)/PLA-RP-AA)/High ceiling (PLH/PLA-P-KA(H), PCH/PCA)		3		
No. of air outlets	4 directions	09	1		
	3 directions		2	–	
	2 directions		3		
Installed options (high-performance filter)	Not supported	10	1	–	
	Supported		2		
Up/down vane setting	No vanes	11	1		
	Equipped with vanes (vaner angle setup ①)		2	–	
	Equipped with vanes (vaner angle setup ②)		3		
Energy saving air flow (Heating mode)	Disabled	12	1	–	
	Enabled		2		

## 8. Duct work

### 8. Duct work

- Connect canvas duct between unit and duct. (Fig. 8-1)
- Use incombustible material for duct parts.
- Provide full insulation to inlet duct flange and outlet duct to prevent condensation.
- Be sure to change the position of air filter to a position where it can be serviced.

<A> In case of rear inlet

<B> In case of bottom inlet

Ⓐ Duct

Ⓑ Air inlet

Ⓒ Access door

Ⓓ Canvas duct

Ⓔ Ceiling surface

Ⓕ Air outlet

Ⓖ Leave distance enough to prevent short cycle

- Procedure for changing the rear inlet to the bottom inlet. (Fig. 8-2)

1. Remove air filter.
2. Remove the bottom plate and flange.
3. Fit the bottom plate to the rear of the body.
4. Fit filter to the underside of the body with screws.

Ⓐ Flange

Ⓑ Filter

Ⓒ Bottom plate

Ⓓ Screws for filter fitting

#### ⚠ Caution:

**An inlet duct of 850 mm or more should be constructed.**

**To connect the air conditioner main body and the duct for potential equalization.**

## 9. Test run

### 9.1. Before test run

- ▶ **After completing installation of the wiring and piping of the indoor and outdoor units, check for refrigerant leakage, looseness in the power supply or control wiring, wrong polarity, and no disconnection of one phase in the supply.**
- ▶ **Use a 500-volt megohmmeter to check that the resistance between the power supply terminals and ground is at least 1.0MΩ.**
- ▶ **Do not carry out this test on the control wiring (low voltage circuit) terminals.**

#### ⚠ Warning:

**Do not use the air conditioner if the insulation resistance is less than 1.0MΩ.**

### 9.2. Test run

The following 2 methods are available.

#### 9.2.1. Using wired remote controller (Fig. 9-1)

- ① Turn on the power at least 12 hours before the test run.
- ② Press the [TEST] button twice. ⇒ "TEST RUN" liquid crystal display
- ③ Press the [Mode selection] button. ⇒ Make sure that wind is blown out.
- ④ Press the [Mode selection] button and switch to the cooling (or heating) mode.  
⇒ Make sure that cold (or warm) wind is blown out.
- ⑤ Press the [Fan speed] button. ⇒ Make sure that the wind speed is switched.
- ⑥ Switch the wind direction by pressing the [Airflow] or [Louver] button.  
⇒ Make sure that horizontal outlet, downward outlet, and other wind direction adjustments are possible.  
⇒ Check operation of the outdoor unit fan.
- ⑦ Release test run by pressing the [ON/OFF] button. ⇒ Stop
- ⑧ After the checks, always turn off the power.

#### 9.2.2. Using SW4 in outdoor unit

Refer to the outdoor unit installation manual.

### 9.3. Self-check

#### 9.3.1. Wired remote controller (Fig. 9-2)

- ① Turn on the power.
- ② Press the [CHECK] button twice.
- ③ Set refrigerant address with [TEMP] button if system control is used.
- ④ Press the [ON/OFF] button to stop the self-check.
  - Ⓐ CHECK button
  - Ⓑ Refrigerant address
  - Ⓒ TEMP. button
  - Ⓓ IC: Indoor unit
  - OC: Outdoor unit
  - Ⓔ Check code
  - Ⓕ Unit address

## 9. Test run

## 10. System controll

• For description of each check code, refer to the following table.

① Check code	Symptom	② Buzzer sound	③ OPE LED
P1	Intake sensor error	Single beep × 1	Lit for 1 sec. × 1
P2	Pipe sensor error	Single beep × 2	Lit for 1 sec. × 2
P4	Drain sensor error	Single beep × 4	Lit for 1 sec. × 4
P5	Drain pump error	Single beep × 5	Lit for 1 sec. × 5
P6	Freezing / Overheating safeguard operation	Single beep × 6	Lit for 1 sec. × 6
P8	Pipe temperature error	Single beep × 8	Lit for 1 sec. × 8
P9	TH5 sensor error	Single beep × 2	Lit for 1 sec. × 2
U0-UP	Outdoor unit error	Double beep × 1	Lit for 0.4 sec. + 0.4 sec. × 1
F1-FA	Outdoor unit error	Double beep × 1	Lit for 0.4 sec. + 0.4 sec. × 1
E0-E5	Signal error between remote controller and indoor units	Sounds other than above	Lights other than above
E6-EF	Communication error between indoor and outdoor units	Sounds other than above	Lights other than above
--	No alarm history	No sound	Not lit
F F F F	No unit	Triple beep	Not lit

• If the unit cannot be operated properly after the above test run has been performed, refer to the following table to remove the cause.

Symptom		Cause
Wired remote controller	LED 1, 2 (PCB in outdoor unit)	
H0	For about 2 minutes following power-on	After LED 1, 2 are lighted, LED 2 is turned off, then only LED 1 is lighted. (Correct operation)
H0 → Error code	After about 2 minutes has expired following power-on	Only LED 1 is lighted. → LED 1, 2 blink.
Display messages do not appear even when operation switch is turned ON (operation lamp does not light up).		Only LED 1 is lighted. → LED 1 blinks twice, LED 2 blinks once.

### Note:

**Operation is not possible for about 30 seconds after cancellation of function selection. (Correct operation)**

For description of each LED (LED1, 2, 3) provided on the indoor controller, refer to the following table.

LED1 (power for microcomputer)	Indicates whether control power is supplied. Make sure that this LED is always lit.
LED2 (power for remote controller)	Indicates whether power is supplied to the remote controller. This LED lights only in the case of the indoor unit which is connected to the outdoor unit refrigerant address "0".
LED3 (communication between indoor and outdoor units)	Indicates state of communication between the indoor and outdoor units. Make sure that this LED is always blinking.

## 10. System controll

Refer to the outdoor unit installation manual.

This product is designed and intended for use in the residential,  
commercial and light-industrial environment.

The product at hand is based on the following EU regulations:

- Low Voltage Directive 73/23/ EEC
- Electromagnetic Compatibility Directive 89/336/ EEC

Please be sure to put the contact address/telephone number on  
this manual before handing it to the customer.