

Changes for the Better

AIR-COOLED SPLIT-TYPE
PACKAGED AIR CONDITIONERS

2004

TECHNICAL & SERVICE MANUAL

<Indoor unit>

HEAT PUMP

Models

PEH-RP8MYA

PEH-RP10MYA

For use with the R410A

Contents

	Page
1 SAFETY PRECAUTION	1
2 PART NAMES AND FUNCTIONS	3
3 SPECIFICATIONS	5
4 OUTLINE AND DIMENSIONS	7
5 ELECTRICAL WIRING DIAGRAM	10
6 TECHNICAL DATA	11
[1] Capacity/Input Ratio against Changes in Room Airflow Rate	11
[2] Capacity table	12
[3] Correction factors	16
[4] Airflow Characteristic Curves	17
[5] Center of Gravity (Indoor unit)	17
[6] Standard Operation Data	18
[7] NC Curve (Indoor unit)	19
7 SERVICE DATA	20
[1] Appearance of Equipment	20
[2] Internal Construction	21
[3] Refrigerant Circuit	21
8 FUNCTION OF SWITCH ON INDOOR CIRCUIT BOARD	22
[1] DIP SW1 for model Selection (DIP SW1 has been set at factory)	22
[2] DIP SW2 for Capacity Setting (DIP SW2 has been set at factory)	22
[3] DIP SWE for Emergency Operation	22
9 TEST RUN	23
[1] Before test run	23
[2] Test run procedures	23
[3] Self-diagnosis	25
[4] Remote controller diagnosis	27

1

SAFETY PRECAUTION

CAUTIONS RELATED TO NEW REFRIGERANT

Cautions for units utilizing refrigerant R410A

Use new refrigerant pipes.

In case of using the existing pipes for R22, be careful with the followings.

- Change flare nut to the one provided with this product.
Use a newly flared pipe.
- Avoid using thin pipes.

Make sure that the inside and outside of refrigerant piping is clean and it has no contamination such as sulfur hazardous for use, oxides, dirt, shaving particles, etc. In addition, use pipes with specified thickness.

Contamination inside refrigerant piping can cause deterioration of refrigerant oil etc.

Store the piping to be used during installation indoors and keep both ends of the piping sealed until just before brazing. (Leave elbow joints, etc. in their packaging.)

If dirt, dust or moisture enter into refrigerant cycle, that can cause deterioration of refrigerant oil or malfunction of compressor.

Use ester oil, ether oil or alkylbenzene oil (small amount) as the refrigerant oil applied to flares and flange connections.

If large amount of mineral oil enter, that can cause deterioration of refrigerant oil etc.

Charge refrigerant from liquid phase of gas cylinder.

If the refrigerant is charged from gas phase, composition change may occur in refrigerant and the efficiency will be lowered.

Do not use refrigerant other than R410A.

If other refrigerant (R22 etc.) is used, chlorine in refrigerant can cause deterioration of refrigerant oil etc.

Use a vacuum pump with a reverse flow check valve.

Vacuum pump oil may flow back into refrigerant cycle and that can cause deterioration of refrigerant oil etc.

Use the following tools specifically designed for use with R410A refrigerant.

The following tools are necessary to use R410A refrigerant.

Tools for R410A	
Gauge manifold	Flare tool
Charge hose	Size adjustment gauge
Gas leak detector	Vacuum pump adaptor
Torque wrench	Electronic refrigerant charging scale

Keep the tools with care.

If dirt, dust or moisture enter into refrigerant cycle, that can cause deterioration of refrigerant oil or malfunction of compressor.

Do not use a charging cylinder.

If a charging cylinder is used, the composition of refrigerant will change and the efficiency will be lowered.

Ventilate the room if refrigerant leaks during operation. If refrigerant comes into contact with a flame, poisonous gases will be released.

[1] Cautions for service

- (1) Perform service after collecting the refrigerant left in unit completely.
- (2) Do not release refrigerant in the air.
- (3) After completing service, charge the cycle with specified amount of refrigerant.
- (4) When performing service, install a filter drier simultaneously.
Be sure to use a filter drier for new refrigerant.

[2] Additional refrigerant charge

When charging directly from cylinder

- Check that cylinder for R410A on the market is syphon type.
- Charging should be performed with the cylinder of syphon stood vertically. (Refrigerant is charged from liquid phase.)

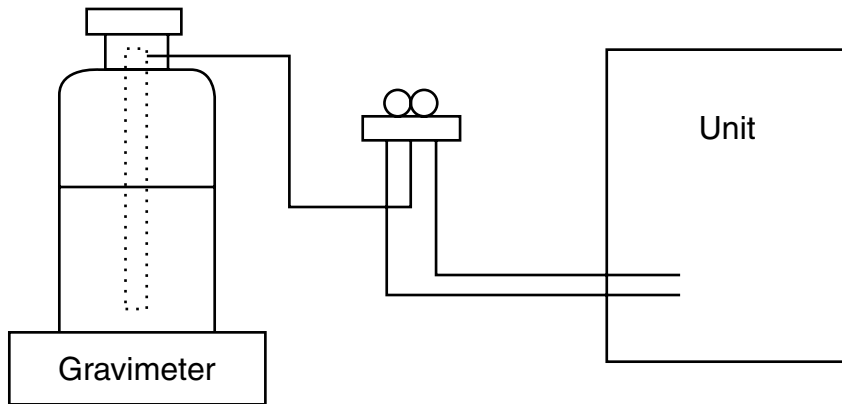

[3] Service tools

Use the below service tools as exclusive tools for R410A refrigerant.

No.		Specifications
①	Gauge manifold	·Only for R410A
		·Use the existing fitting specifications. (UNF1/2)
		·Use high-tension side pressure of 5.3MPa-G or over.
②	Charge hose	·Only for R410A
		·Use pressure performance of 5.09MPa-G or over.
③	Electronic scale	—
④	Gas leak detector	·Use the detector for R134a, R407C or R410A.
⑤	Adaptor for reverse flow check	·Attach on vacuum pump.
⑥	Refrigerant charge base	—
⑦	Refrigerant cylinder	·Only for R410A Top of cylinder (Pink)
		Cylinder with syphon
⑧	Refrigerant recovery equipment	—

2

PART NAMES AND FUNCTIONS

● Indoor Unit PEH-RP8MYA PEH-RP10MYA

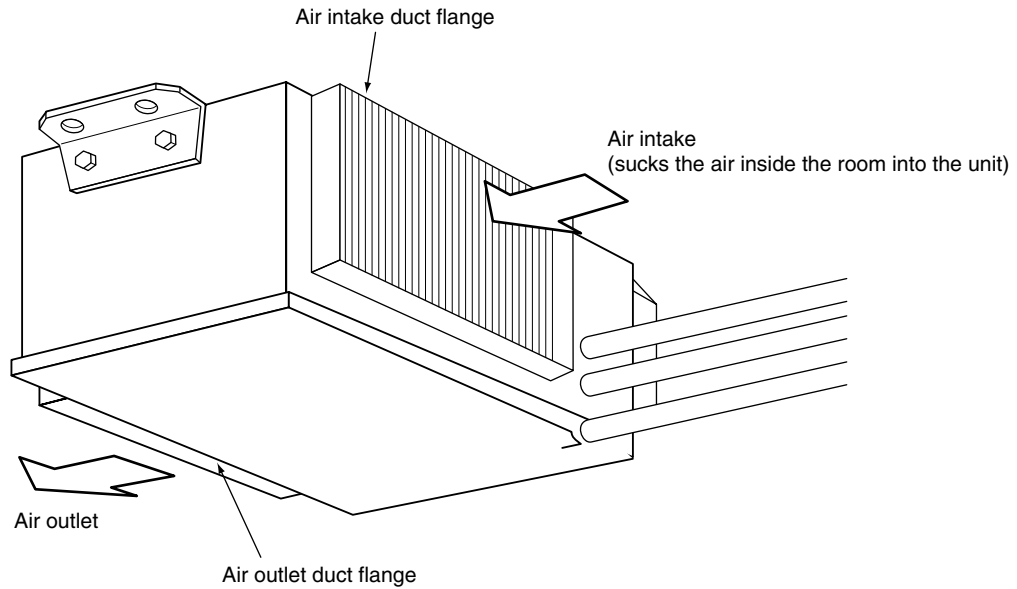

● Operation buttons

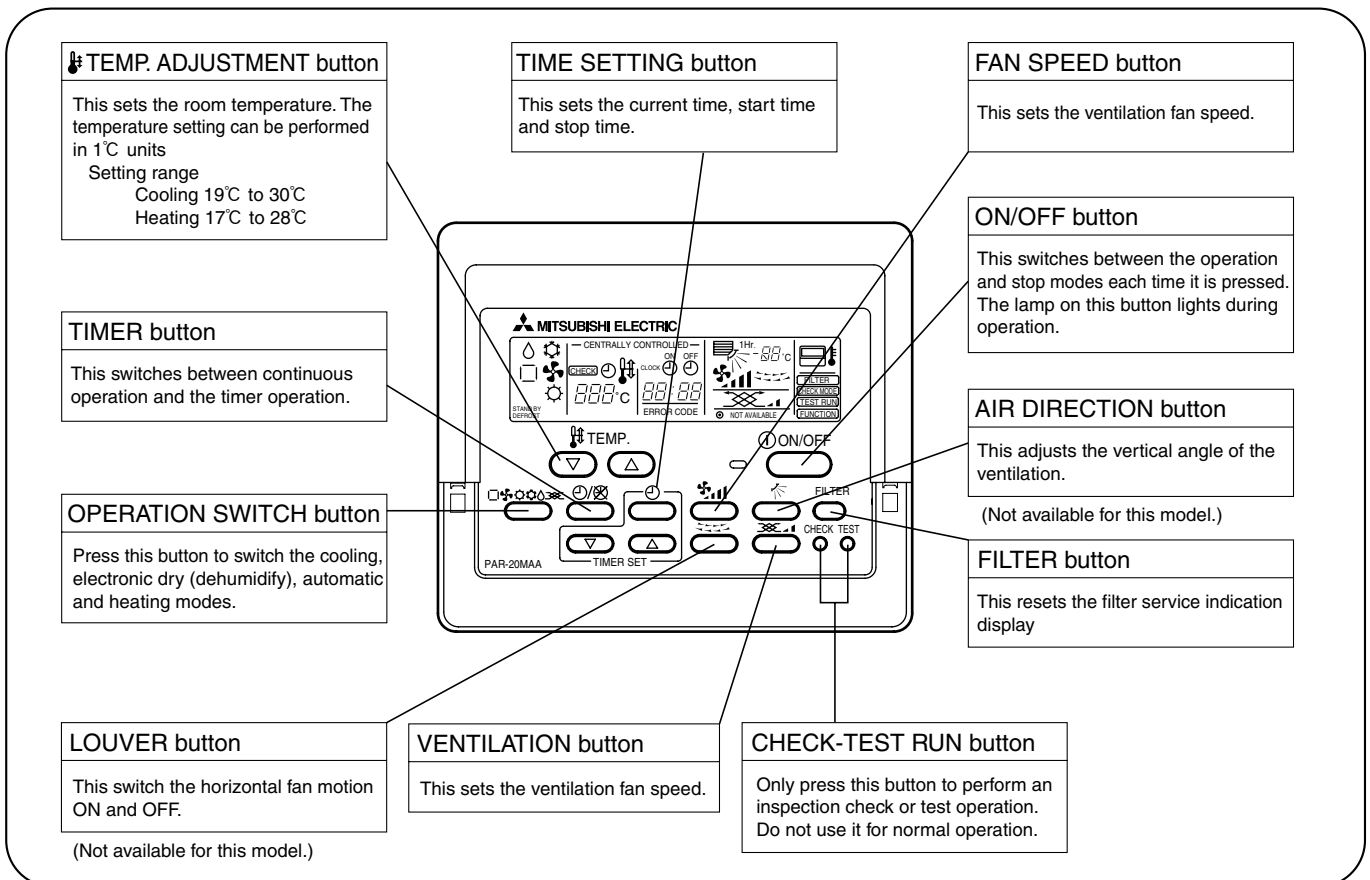

● Display

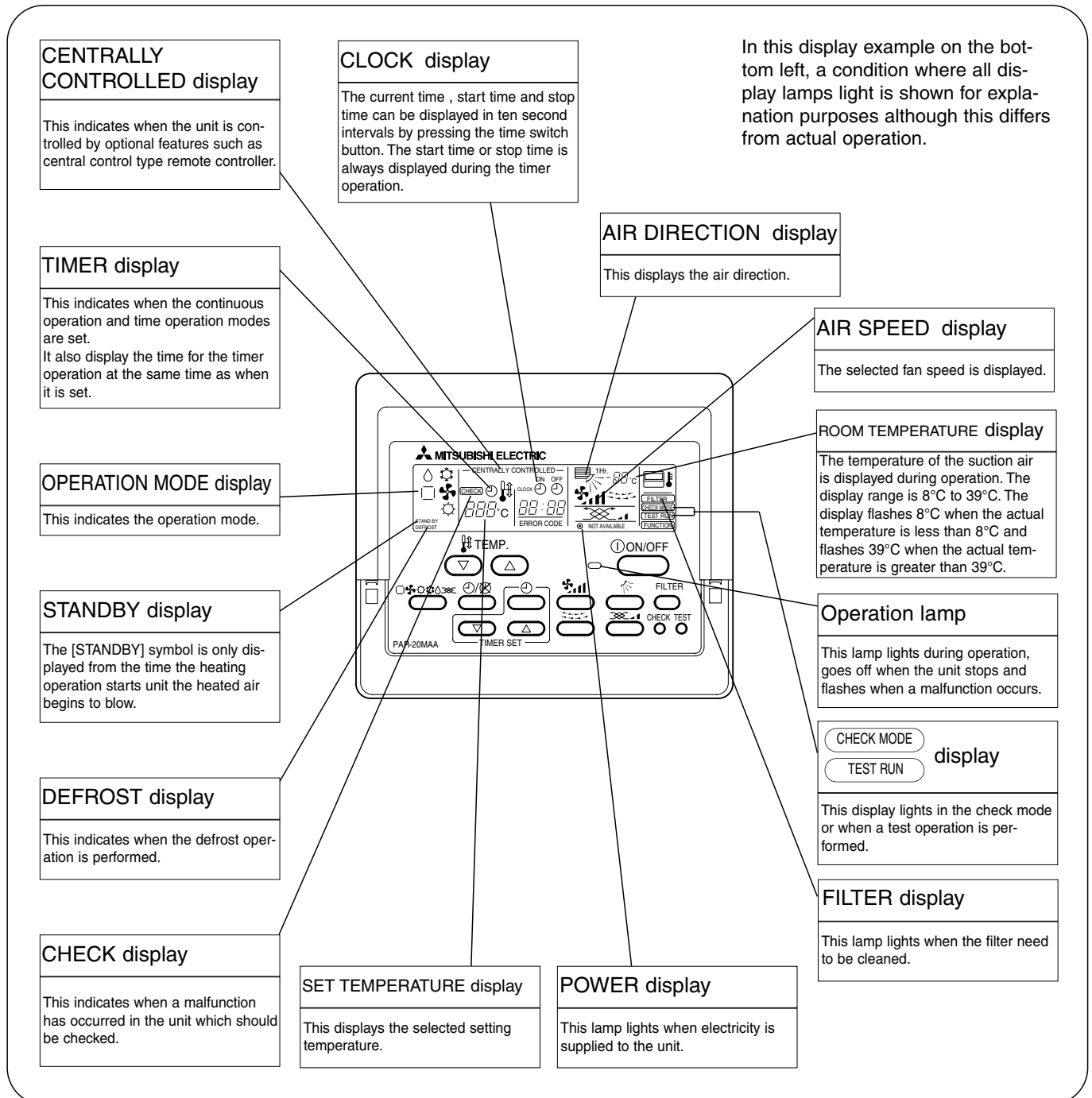

Caution

- Only the Power display lights when the unit is stopped and power supplied to the unit.
- When the central control remote control unit, which is sold separately, is used the ON-OFF button, operation switch button and  TEMP. adjustment button do not operate.
- "NOT AVAILABLE" is displayed when the Air speed button are pressed. This indicates that this room unit is not equipped with the fan direction adjustment function and the louver function.
- When power is turned ON for the first time, it is normal that "HO" is displayed on the room temperature indication (For max. 2minutes). Please wait until this "HO" indication disappear then start the operation.

3

SPECIFICATIONS

Specifications of air-source heat pump type packaged air conditioner (Ceiling concealed type indoor unit)						
Model name		PEH-RP8MYA		Quantity	Symbol	
Service Ref.			PEH-RP8MYA			
			Cooling	Heating		
Capacity				kcal/h	16,300	
				kW	19.0	
Air condition	Indoor side	Dry bulb temperature/wet bulb temperature		27 °C/19 °C	20 °C/–	
	Outdoor side	Dry bulb temperature/wet bulb temperature		35 °C/24 °C	7 °C/6 °C	
Service Ref.			PEH-RP8MYA			
Power source			3N~ 380/400/415V 50Hz			
Electrical characteristics		Power consumption		kW	0.65/0.65/0.65	
		Operating current		A	1.12/1.12/1.12	
Remote controller temperature setting range			°C	19 ~ 30	17 ~ 28	
Airflow direction control			–			
Fan		Type × Quantity		Sirrocco fan × 2		
		Airflow rate		m ³ /min	60	
		External static pressure		Pa	50/150	
		Motor output		kW	0.75	
External finish			Galvanizing			
External dimension		Unit (H × W × D)		mm	428 × 1380 × 650	
		Panel (H × W × D)		mm	–	
Heat exchanger type			Cross fin			
Air filter			Saran net			
Insulation material			Polyethylene foam			
Refrigerant piping size Liquid/Gas			φmm	9.52/25.4		
Drain piping size			φmm	25.4 (RC1)		
Noise level			dB(A)	49 (at 50 Pa)		
Net weight			kg	70		
External wiring		Minimum wire thickness		1.6 mm		
		Circuit breaker		15 A		
Composing parts		Operation control device (provided)		Remote controller: PAR-20MAA		
		Decoration panel (Option)		–		
Other mountable major options			–			
Accessories			Installation manual, Operation manual, Remote controller			
Special note, Non-standard specifications, etc.			–			
Outdoor unit	Service Ref.		PUHZ-RP8YHA			
Notes:	<ol style="list-style-type: none"> The cooling and heating capacities are the maximum capacities that were obtained by operating in the above air conditions and with a refrigerant pipe of about 7.5 m. The actual capacity characteristics vary with the combination of indoor and outdoor units. See the technical information. The operating noise is the data that was obtained by measuring it 1.5 m from the unit's bottom in an anechoic room. (Noise meter A-scale value) The figure of Electrical characteristic, Airflow rate, Noise level, indicates, at 50 Pa setting. Refer to the service manual of outdoor unit for the outdoor unit's specifications. 					

**Specifications of air-source heat pump type packaged air conditioner
(Ceiling concealed type indoor unit)**

Model name	PEH-RP10MYA		Quantity		Symbol		
Service Ref.			PEH-RP10MYA				
			Cooling		Heating		
Capacity			kcal/h	18,900	23,200		
			kW	22.0	27.0		
Air condition	Indoor side	Dry bulb temperature/wet bulb temperature		27 °C/19 °C	20 °C/-		
	Outdoor side	Dry bulb temperature/wet bulb temperature		35 °C/24 °C	7 °C/ 6 °C		
Service Ref.			PEH-RP10MYA				
Power source			3N~ 380/400/415V 50 Hz				
Electrical characteristics		Power consumption	kW	0.94/0.94/0.94	0.94/0.94/0.94		
		Operating current	A	1.64/1.64/1.64	1.64/1.64/1.64		
Remote controller temperature setting range			°C	19 ~ 30	17 ~ 28		
Airflow direction control			-				
Fan	Type × Quantity		Sirrocco fan × 2				
	Airflow rate		m ³ /min	80			
	External static pressure		Pa	50/150			
	Motor output		kW	1.23			
External finish			Galvanizing				
External dimension		Unit (H × W × D)	mm	428 × 1,580 × 650			
		Panel (H × W × D)	mm	-			
Indoor unit	Heat exchanger type			Cross fin			
	Air filter			Saran net			
	Insulation material			Polyethylene foam			
	Refrigerant piping size Liquid/Gas			φ mm	12.7/28.58		
	Drain piping size			φ mm	25.4 (RC1)		
	Noise level			dB(A)	53 (at 50 Pa)		
	Net weight			kg	80		
	External wiring		Minimum wire thickness		1.6 mm		
			Circuit breaker		15 A		
	Composing parts		Operation control device (provided)		Remote controller: PAR-20MAA		
			Decoration panel (Option)		-		
	Other mountable major options			-			
	Accessories			Installation manual, Operation manual, Remote controller			
	Special note, Non-standard specifications, etc.			-			
	Outdoor unit	Service Ref.		PUHZ-RP10YHA			
	Notes:	<ol style="list-style-type: none"> The cooling and heating capacities are the maximum capacities that were obtained by operating in the above air conditions and with a refrigerant pipe of about 7.5 m. The actual capacity characteristics vary with the combination of indoor and outdoor units. See the technical information. The operating noise is the data that was obtained by measuring it 1.5 m from the unit's bottom in an anechoic room. (Noise meter A-scale value) The figure of Electrical characteristic, Airflow rate, Noise level, indicates, at 50 Pa setting. Refer to the service manual of outdoor unit for the outdoor unit's specifications. 					

4

OUTLINE AND DIMENSIONS

(1) Indoor Unit

• Model PEH-RP8MYA

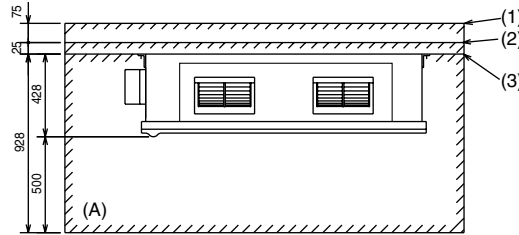
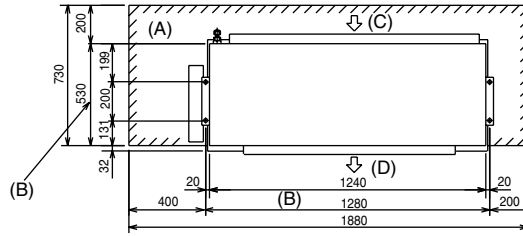

- (1) When connecting air inlet
- (2) When installing the suspension fixtures prior to installation of the indoor unit without inlet duct
- (3) When hanging the indoor unit directly without inlet duct

- (A) Service space
- (B) Suspension bolt pitch
- (C) Air inlet
- (D) Air outlet

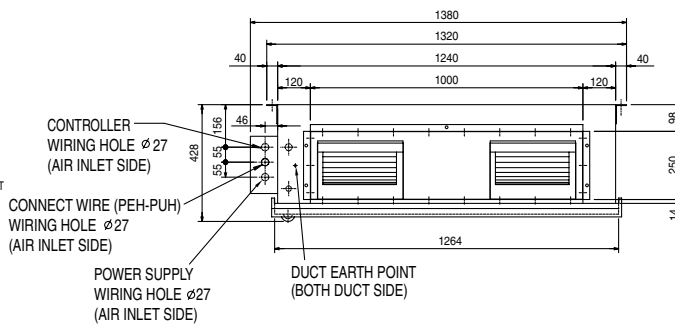
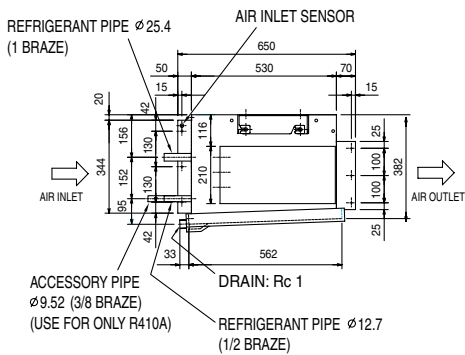
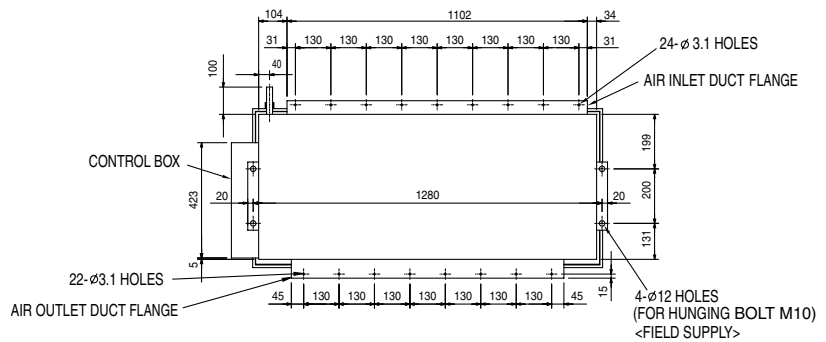

Note: When connecting duct to the inlet side, remove the air filter attached to the unit body, and mount an air filter onto the inlet duct side separately.

(2) Remote Controller

- Model PAR-20MAA

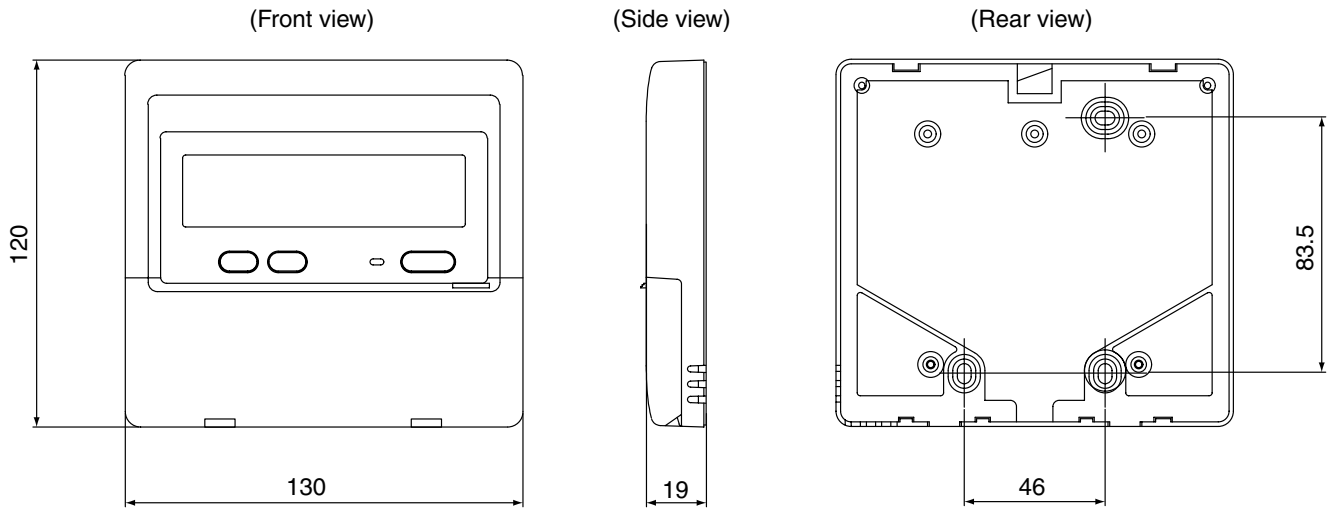

(1) Indoor Unit

• Models PEH-RP8MYA/RP10MYA

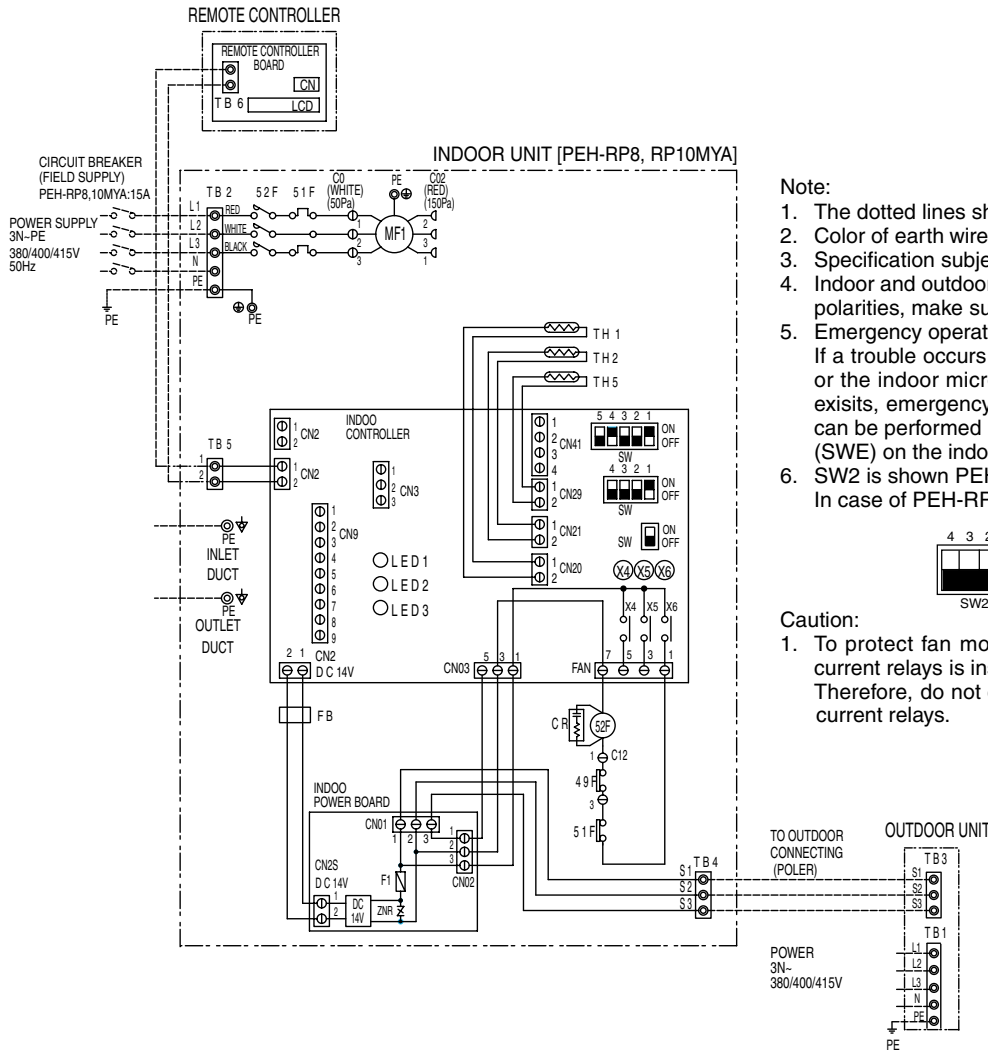

Note:

1. The dotted lines show field wiring.
2. Color of earth wire is yellow and green twisting.
3. Specification subject to change without notice.
4. Indoor and outdoor connecting wires are made with polarities, make sure matching wiring and terminal.
5. Emergency operation
If a trouble occurs with either the remote controller or the indoor microcomputer and no other trouble exists, emergency operation for cooling or heating can be performed by changing the setting of switch (SWE) on the indoor controller board.
6. SW2 is shown PEH-RP10MYA setting.
In case of PEH-RP8MYA setting is shown as below.

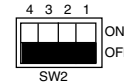

Caution:

1. To protect fan motor from abnormal current, over current relays is installed.
Therefore, do not change factory set value of over current relays.

INDOOR UNIT

SYMBOL	NAME
MF1	FAN MOTOR (INDOOR)
51F	OVER CURRENT RELAY (INDOOR FAN MOTOR)
52F	CONTACTOR (INDOOR FAN MOTOR)
49F	INTERNAL THERMOSTAT (INDOOR FAN MOTOR)
TB2, 4, 5	TERMINAL BLOCK
TH1	ROOM TEMP. (0°C/15kΩ, 25°C/5.4kΩ)
TH2	PIPE TEMP. (0°C/15kΩ, 25°C/5.4kΩ)
TH5	COND./EVA. TEMP. (0°C/15kΩ, 25°C/5.4kΩ)
F1	FUSE (4A 250VAC CLASS T)
ZNR	VARIATOR
X4-6	AUXILIARY RELAY (INDOOR CONTROLLER BOARD)
SW1	SWITCH (MODEL SELECTION)
SW2	SWITCH (CAPACITY CORD)
SWE	SWITCH (EMERGENCY OPERATION)
LED1	LED (POWER SUPPLY : INDOOR CONTROLLER BOARD)
LED2	LED (POWER SUPPLY : REMOTE CONTROLLER)
LED3	LED (TRANSMISSION : INDOOR-OUTDOOR)
CR	SURGE KILLER
CN03, CN21, 2D CN20-22, 29, 32 CN41, 90, FAN	CONNECTOR (INDOOR CONTROLLER BOARD)
CN01, 02, 2S	CONNECTOR (INDOOR POWER BOARD)
C01, 02, 12	CONNECTOR (FAN MOTOR)
FB	FERRITE CORE

OUTDOOR UNIT

SYMBOL	NAME
TB3	TERMINAL BLOCK

REMOTE CONTROLLER

SYMBOL	NAME
TB6	TERMINAL BLOCK

6

TECHNICAL DATA

[1] Capacity/Input Ratio against Changes in Room Airflow Rate

• Model PEH-RP8MYA

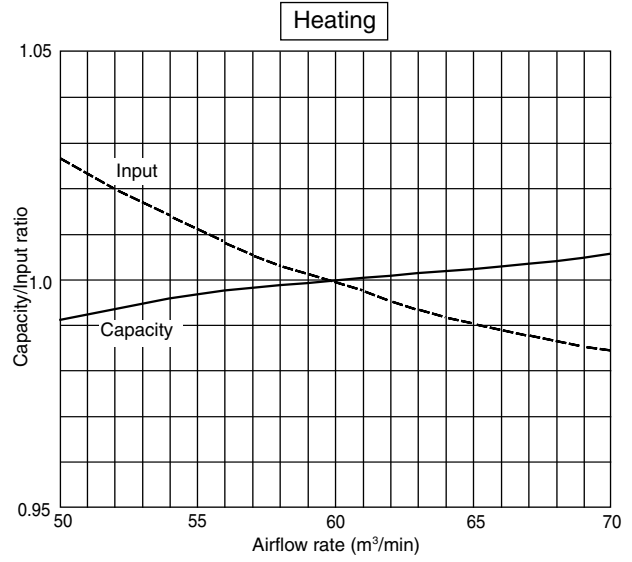
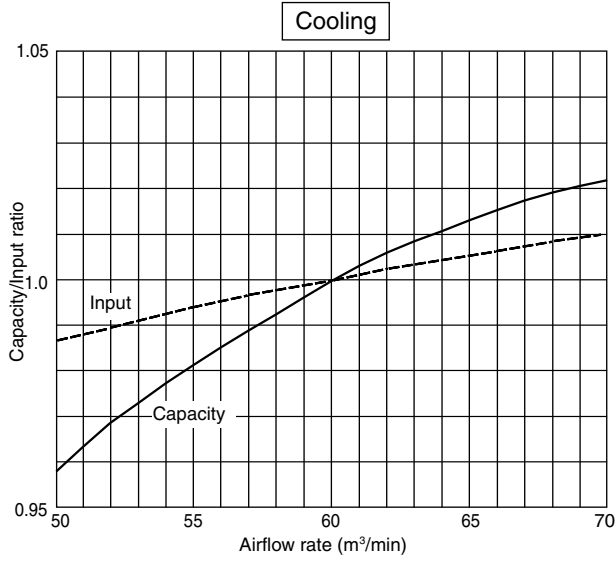

• Model PEH-RP10MYA

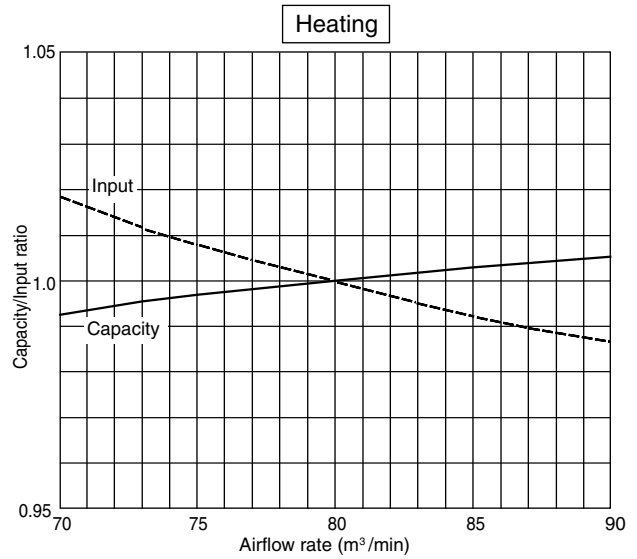
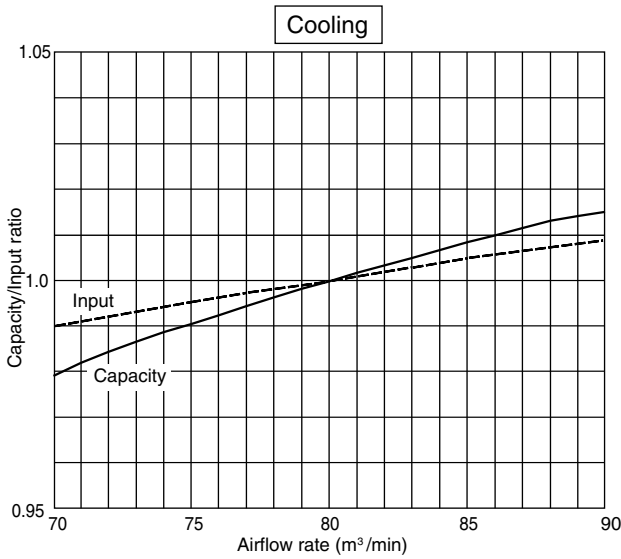

[2] Capacity table

COOLING CAPACITY (1)

PEH-RP8MYA/PUHZ-RP8YHA (Indoor unit Airflow rate 60m³/min)

Indoor intake air DB°C	Indoor intake air WB°C	Outdoor intake air DB°C											
		20				25				30			
		CA	SHC(W)	SHF	P.C.	CA	SHC(W)	SHF	P.C.	CA	SHC(W)	SHF	P.C.
20	16	18810	12227	0.65	5.82	18240	11856	0.65	6.15	17670	11486	0.65	6.52
	18	20140	10674	0.53	5.93	19570	10372	0.53	6.26	18905	10020	0.53	6.70
	20	21660	8881	0.41	6.12	21185	8686	0.41	6.41	20615	8452	0.41	6.84
22	16	18810	13731	0.73	5.82	18240	13315	0.73	6.15	17670	12899	0.73	6.52
	18	20140	12285	0.61	5.93	19570	11938	0.61	6.26	18905	11532	0.61	6.70
	20	21660	10613	0.49	6.12	21185	10381	0.49	6.41	20615	10101	0.49	6.84
24	16	18810	15236	0.81	5.82	18240	14774	0.81	6.15	17670	14313	0.81	6.52
	18	20140	13897	0.69	5.93	19570	13503	0.69	6.26	18905	13044	0.69	6.70
	20	21660	12346	0.57	6.12	21185	12075	0.57	6.41	20615	11751	0.57	6.84
	22	23085	10388	0.45	6.26	22610	10175	0.45	6.62	22040	9918	0.45	7.06
26	16	18810	16741	0.89	5.82	18240	16234	0.89	6.15	17670	15726	0.89	6.52
	18	20140	15508	0.77	5.93	19570	15069	0.77	6.26	18905	14557	0.77	6.70
	20	21660	14079	0.65	6.12	21185	13770	0.65	6.41	20615	13400	0.65	6.84
	22	23085	12235	0.53	6.26	22610	11983	0.53	6.62	22040	11681	0.53	7.06
27	16	18810	17493	0.93	5.82	18240	16963	0.93	6.15	17670	16433	0.93	6.52
	18	20140	16313	0.81	5.93	19570	15852	0.81	6.26	18905	15313	0.81	6.70
	20	21660	14945	0.69	6.12	21185	14618	0.69	6.41	20615	14224	0.69	6.84
	22	23085	13158	0.57	6.26	22610	12888	0.57	6.62	22040	12563	0.57	7.06
28	16	18810	18246	0.97	5.82	18240	17693	0.97	6.15	17670	17140	0.97	6.52
	18	20140	17119	0.85	5.93	19570	16635	0.85	6.26	18905	16069	0.85	6.70
	20	21660	15812	0.73	6.12	21185	15465	0.73	6.41	20615	15049	0.73	6.84
	22	23085	14082	0.61	6.26	22610	13792	0.61	6.62	22040	13444	0.61	7.06
30	16	18810	18810	1.00	5.82	18240	18240	1.00	6.15	17670	17670	1.00	6.52
	18	20140	18730	0.93	5.93	19570	18200	0.93	6.26	18905	17582	0.93	6.70
	20	21660	17545	0.81	6.12	21185	17160	0.81	6.41	20615	16698	0.81	6.84
	22	23085	15929	0.69	6.26	22610	15601	0.69	6.62	22040	15208	0.69	7.06
32	16	18810	18810	1.00	5.82	18240	18240	1.00	6.15	17670	17670	1.00	6.52
	18	20140	20140	1.00	5.93	19570	19570	1.00	6.26	18905	18905	1.00	6.70
	20	21660	19277	0.89	6.12	21185	18855	0.89	6.41	20615	18347	0.89	6.84
	22	23085	17775	0.77	6.26	22610	17410	0.77	6.62	22040	16971	0.77	7.06
34	16	18810	18810	1.00	5.82	18240	18240	1.00	6.15	17670	17670	1.00	6.52
	18	20140	20140	1.00	5.93	19570	19570	1.00	6.26	18905	18905	1.00	6.70
	20	21660	21010	0.97	6.12	21185	20549	0.97	6.41	20615	19997	0.97	6.84
	22	23085	19622	0.85	6.26	22610	19219	0.85	6.62	22040	18734	0.85	7.06

NOTE: CA : Capacity (W) SHC : Sensible heat capacity (W)
P.C. : Power consumption (kW) SHF : Sensible heat factor

COOLING CAPACITY (2)

PEH-RP8MYA/PUHZ-RP8YHA

(Indoor unit Airflow rate 60m³/min)

Indoor intake air DB°C	Indoor intake air WB°C	Outdoor intake air DB°C											
		35				40				45			
		CA	SHC(W)	SHF	P.C.	CA	SHC(W)	SHF	P.C.	CA	SHC(W)	SHF	P.C.
20	16	16910	10992	0.65	6.99	16150	10498	0.65	7.50	15390	10004	0.65	8.12
	18	18240	9667	0.53	7.17	17670	9365	0.53	7.72	16530	8761	0.53	8.30
	20	19760	8102	0.41	7.35	19000	7790	0.41	7.86	17860	7323	0.41	8.44
22	16	16910	12344	0.73	6.99	16150	11790	0.73	7.50	15390	11235	0.73	8.12
	18	18240	11126	0.61	7.17	17670	10779	0.61	7.72	16530	10083	0.61	8.30
	20	19760	9682	0.49	7.35	19000	9310	0.49	7.86	17860	8751	0.49	8.44
24	16	16910	13697	0.81	6.99	16150	13082	0.81	7.50	15390	12466	0.81	8.12
	18	18240	12586	0.69	7.17	17670	12192	0.69	7.72	16530	11406	0.69	8.30
	20	19760	11263	0.57	7.35	19000	10830	0.57	7.86	17860	10180	0.57	8.44
	22	21280	9576	0.45	7.50	20520	9234	0.45	8.08	19380	8721	0.45	8.59
26	16	16910	15050	0.89	6.99	16150	14374	0.89	7.50	15390	13697	0.89	8.12
	18	18240	14045	0.77	7.17	17670	13606	0.77	7.72	16530	12728	0.77	8.30
	20	19760	12844	0.65	7.35	19000	12350	0.65	7.86	17860	11609	0.65	8.44
	22	21280	11278	0.53	7.50	20520	10876	0.53	8.08	19380	10271	0.53	8.59
27	16	16910	15726	0.93	6.99	16150	15020	0.93	7.50	15390	14313	0.93	8.12
	18	18240	14774	0.81	7.17	17670	14313	0.81	7.72	16530	13389	0.81	8.30
	20	19760	13634	0.69	7.35	19000	13110	0.69	7.86	17860	12323	0.69	8.44
	22	21280	12130	0.57	7.50	20520	11696	0.57	8.08	19380	11047	0.57	8.59
28	16	16910	16403	0.97	6.99	16150	15666	0.97	7.50	15390	14928	0.97	8.12
	18	18240	15504	0.85	7.17	17670	15020	0.85	7.72	16530	14051	0.85	8.30
	20	19760	14425	0.73	7.35	19000	13870	0.73	7.86	17860	13038	0.73	8.44
	22	21280	12981	0.61	7.50	20520	12517	0.61	8.08	19380	11822	0.61	8.59
30	16	16910	16910	1.00	6.99	16150	16150	1.00	7.50	15390	15390	1.00	8.12
	18	18240	16963	0.93	7.17	17670	16433	0.93	7.72	16530	15373	0.93	8.30
	20	19760	16006	0.81	7.35	19000	15390	0.81	7.86	17860	14467	0.81	8.44
	22	21280	14683	0.69	7.50	20520	14159	0.69	8.08	19380	13372	0.69	8.59
32	16	16910	16910	1.00	6.99	16150	16150	1.00	7.50	15390	15390	1.00	8.12
	18	18240	18240	1.00	7.17	17670	17670	1.00	7.72	16530	16530	1.00	8.30
	20	19760	17586	0.89	7.35	19000	16910	0.89	7.86	17860	15895	0.89	8.44
	22	21280	16386	0.77	7.50	20520	15800	0.77	8.08	19380	14923	0.77	8.59
34	16	16910	16910	1.00	6.99	16150	16150	1.00	7.50	15390	15390	1.00	8.12
	18	18240	18240	1.00	7.17	17670	17670	1.00	7.72	16530	16530	1.00	8.30
	20	19760	19167	0.97	7.35	19000	18430	0.97	7.86	17860	17324	0.97	8.44
	22	21280	18088	0.85	7.50	20520	17442	0.85	8.08	19380	16473	0.85	8.59

NOTE: CA : Capacity (W) SHC : Sensible heat capacity (W)
P.C. : Power consumption (kW) SHF : Sensible heat factor

COOLING CAPACITY (3)

PEH-RP10MYA/PUHZ-RP10YHA (Indoor unit Airflow rate 80m³/min)

Indoor intake air DB°C	Indoor intake air WB°C	Outdoor intake air DB°C											
		20				25				30			
		CA	SHC(W)	SHF	P.C.	CA	SHC(W)	SHF	P.C.	CA	SHC(W)	SHF	P.C.
20	16	21780	15682	0.72	6.74	21120	15206	0.72	7.12	20460	14731	0.72	7.54
	18	23320	13992	0.60	6.87	22660	13596	0.60	7.25	21890	13134	0.60	7.76
	20	25080	12038	0.48	7.08	24530	11774	0.48	7.42	23870	11458	0.48	7.92
22	16	21780	17424	0.80	6.74	21120	16896	0.80	7.12	20460	16368	0.80	7.54
	18	23320	15858	0.68	6.87	22660	15409	0.68	7.25	21890	14885	0.68	7.76
	20	25080	14045	0.56	7.08	24530	13737	0.56	7.42	23870	13367	0.56	7.92
24	16	21780	19166	0.88	6.74	21120	18586	0.88	7.12	20460	18005	0.88	7.54
	18	23320	17723	0.76	6.87	22660	17222	0.76	7.25	21890	16636	0.76	7.76
	20	25080	16051	0.64	7.08	24530	15699	0.64	7.42	23870	15277	0.64	7.92
	22	26730	13900	0.52	7.25	26180	13614	0.52	7.67	25520	13270	0.52	8.18
26	16	21780	20909	0.96	6.74	21120	20275	0.96	7.12	20460	19642	0.96	7.54
	18	23320	19589	0.84	6.87	22660	19034	0.84	7.25	21890	18388	0.84	7.76
	20	25080	18058	0.72	7.08	24530	17662	0.72	7.42	23870	17186	0.72	7.92
	22	26730	16038	0.60	7.25	26180	15708	0.60	7.67	25520	15312	0.60	8.18
27	16	21780	21780	1.00	6.74	21120	21120	1.00	7.12	20460	20460	1.00	7.54
	18	23320	20522	0.88	6.87	22660	19941	0.88	7.25	21890	19263	0.88	7.76
	20	25080	19061	0.76	7.08	24530	18643	0.76	7.42	23870	18141	0.76	7.92
	22	26730	17107	0.64	7.25	26180	16755	0.64	7.67	25520	16333	0.64	8.18
28	16	21780	21780	1.00	6.74	21120	21120	1.00	7.12	20460	20460	1.00	7.54
	18	23320	21454	0.92	6.87	22660	20847	0.92	7.25	21890	20139	0.92	7.76
	20	25080	20064	0.80	7.08	24530	19624	0.80	7.42	23870	19096	0.80	7.92
	22	26730	18176	0.68	7.25	26180	17802	0.68	7.67	25520	17354	0.68	8.18
30	16	21780	21780	1.00	6.74	21120	21120	1.00	7.12	20460	20460	1.00	7.54
	18	23320	23320	1.00	6.87	22660	22660	1.00	7.25	21890	21890	1.00	7.76
	20	25080	22070	0.88	7.08	24530	21586	0.88	7.42	23870	21006	0.88	7.92
	22	26730	20315	0.76	7.25	26180	19897	0.76	7.67	25520	19395	0.76	8.18
32	16	21780	21780	1.00	6.74	21120	21120	1.00	7.12	20460	20460	1.00	7.54
	18	23320	23320	1.00	6.87	22660	22660	1.00	7.25	21890	21890	1.00	7.76
	20	25080	24077	0.96	7.08	24530	23549	0.96	7.42	23870	22915	0.96	7.92
	22	26730	22453	0.84	7.25	26180	21991	0.84	7.67	25520	21437	0.84	8.18
34	16	21780	21780	1.00	6.74	21120	21120	1.00	7.12	20460	20460	1.00	7.54
	18	23320	23320	1.00	6.87	22660	22660	1.00	7.25	21890	21890	1.00	7.76
	20	25080	25080	1.00	7.08	24530	24530	1.00	7.42	23870	23870	1.00	7.92
	22	26730	24592	0.92	7.25	26180	24086	0.92	7.67	25520	23478	0.92	8.18

NOTE: CA : Capacity (W) SHC : Sensible heat capacity (W)
P.C. : Power consumption (kW) SHF : Sensible heat factor

COOLING CAPACITY (4)

PEH-RP10MYA/PUHZ-RP10YHA (Indoor unit Airflow rate 80m³/min)

Indoor intake air DB°C	Indoor intake air WB°C	Outdoor intake air DB°C											
		35				40				45			
		CA	SHC(W)	SHF	P.C.	CA	SHC(W)	SHF	P.C.	CA	SHC(W)	SHF	P.C.
20	16	19580	14098	0.72	8.09	18700	13464	0.72	8.68	17820	12830	0.72	9.40
	18	21120	12672	0.60	8.30	20460	12276	0.60	8.94	19140	11484	0.60	9.61
	20	22880	10982	0.48	8.51	22000	10560	0.48	9.10	20680	9926	0.48	9.78
22	16	19580	15664	0.80	8.09	18700	14960	0.80	8.68	17820	14256	0.80	9.40
	18	21120	14362	0.68	8.30	20460	13913	0.68	8.94	19140	13015	0.68	9.61
	20	22880	12813	0.56	8.51	22000	12320	0.56	9.10	20680	11581	0.56	9.78
24	16	19580	17230	0.88	8.09	18700	16456	0.88	8.68	17820	15682	0.88	9.40
	18	21120	16051	0.76	8.30	20460	15550	0.76	8.94	19140	14546	0.76	9.61
	20	22880	14643	0.64	8.51	22000	14080	0.64	9.10	20680	13235	0.64	9.78
	22	24640	12813	0.52	8.68	23760	12355	0.52	9.36	22440	11669	0.52	9.95
26	16	19580	18797	0.96	8.09	18700	17952	0.96	8.68	17820	17107	0.96	9.40
	18	21120	17741	0.84	8.30	20460	17186	0.84	8.94	19140	16078	0.84	9.61
	20	22880	16474	0.72	8.51	22000	15840	0.72	9.10	20680	14890	0.72	9.78
	22	24640	14784	0.60	8.68	23760	14256	0.60	9.36	22440	13464	0.60	9.95
27	16	19580	19580	1.00	8.09	18700	18700	1.00	8.68	17820	17820	1.00	9.40
	18	21120	18586	0.88	8.30	20460	18005	0.88	8.94	19140	16843	0.88	9.61
	20	22880	17389	0.76	8.51	22000	16720	0.76	9.10	20680	15717	0.76	9.78
	22	24640	15770	0.64	8.68	23760	15206	0.64	9.36	22440	14362	0.64	9.95
28	16	19580	19580	1.00	8.09	18700	18700	1.00	8.68	17820	17820	1.00	9.40
	18	21120	19430	0.92	8.30	20460	18823	0.92	8.94	19140	17609	0.92	9.61
	20	22880	18304	0.80	8.51	22000	17600	0.80	9.10	20680	16544	0.80	9.78
	22	24640	16755	0.68	8.68	23760	16157	0.68	9.36	22440	15259	0.68	9.95
30	16	19580	19580	1.00	8.09	18700	18700	1.00	8.68	17820	17820	1.00	9.40
	18	21120	21120	1.00	8.30	20460	20460	1.00	8.94	19140	19140	1.00	9.61
	20	22880	20134	0.88	8.51	22000	19360	0.88	9.10	20680	18198	0.88	9.78
	22	24640	18726	0.76	8.68	23760	18058	0.76	9.36	22440	17054	0.76	9.95
32	16	19580	19580	1.00	8.09	18700	18700	1.00	8.68	17820	17820	1.00	9.40
	18	21120	21120	1.00	8.30	20460	20460	1.00	8.94	19140	19140	1.00	9.61
	20	22880	21965	0.96	8.51	22000	21120	0.96	9.10	20680	19853	0.96	9.78
	22	24640	20698	0.84	8.68	23760	19958	0.84	9.36	22440	18850	0.84	9.95
34	16	19580	19580	1.00	8.09	18700	18700	1.00	8.68	17820	17820	1.00	9.40
	18	21120	21120	1.00	8.30	20460	20460	1.00	8.94	19140	19140	1.00	9.61
	20	22880	22880	1.00	8.51	22000	22000	1.00	9.10	20680	20680	1.00	9.78
	22	24640	22669	0.92	8.68	23760	21859	0.92	9.36	22440	20645	0.92	9.95

NOTE: CA : Capacity (W) SHC : Sensible heat capacity (W)
P.C. : Power consumption (kW) SHF : Sensible heat factor

**HEATING CAPACITY
PUHZ-RP8YHA/PUHZ-RP10YHA**

Service Ref.	Indoor intake air DB°C	Outdoor intake air WB°C					
		-10		-5		0	
		CA	P.C.	CA	P.C.	CA	P.C.
PEH-RP8MYA (Airflow Rate 60m³/min)	15	14224	4.12	15456	4.54	17248	5.24
	20	13664	4.47	14784	4.89	16352	5.65
	25	13216	4.75	14336	5.30	15680	6.14
PEH-RP10MYA (Airflow Rate 80m³/min)	15	17145	4.96	18630	5.47	20790	6.31
	20	16470	5.38	17820	5.89	19710	6.81
	25	15930	5.72	17280	6.39	18900	7.40

Service Ref.	Indoor intake air DB°C	Outdoor intake air WB°C					
		5		10		15	
		CA	P.C.	CA	P.C.	CA	P.C.
PEH-RP8MYA (Airflow Rate 60m³/min)	15	22624	6.28	25536	6.98	28448	7.54
	20	21840	6.77	24640	7.54	27440	8.10
	25	20608	7.19	23744	8.06	26432	8.69
PEH-RP10MYA (Airflow Rate 80m³/min)	15	27270	7.57	30780	8.41	34290	9.08
	20	26325	8.16	29700	9.08	33075	9.76
	25	24840	8.66	28620	9.71	31860	10.47

NOTE: CA : Capacity (W) P.C. : Power consumption (kW)

[3] CORRECTION FACTORS

Cooling capacity correction factors

Service Ref.	Refrigerent piping length (one way)							
	5m	10m	15m	20m	25m	30m	35m	40m
PEH-RP8MYA	1.00	0.985	0.971	0.958	0.943	0.931	0.919	0.908
PEH-RP10MYA	1.00	0.985	0.971	0.958	0.943	0.931	0.919	0.908

Service Ref.	Refrigerent piping length (one way)							
	45m	50m	55m	60m	65m	70m	75m	80m
PEH-RP8MYA	0.898	0.887	0.876	0.865	0.855	0.847	0.838	0.829
PEH-RP10MYA	0.898	0.887	0.876	0.865	0.855	0.847	0.838	0.829

Heating capacity correction factors

Service Ref.	Refrigerent piping length (one way)							
	5m	10m	15m	20m	25m	30m	35m	40m
PEH-RP8MYA	1.00	0.997	0.994	0.991	0.988	0.985	0.982	0.979
PEH-RP10MYA	1.00	0.997	0.994	0.991	0.988	0.985	0.982	0.979

Service Ref.	Refrigerent piping length (one way)							
	45m	50m	55m	60m	65m	70m	75m	80m
PEH-RP8MYA	0.976	0.973	0.970	0.967	0.964	0.961	0.958	0.955
PEH-RP10MYA	0.976	0.973	0.970	0.967	0.964	0.961	0.958	0.955

[4] Airflow Characteristic Curves

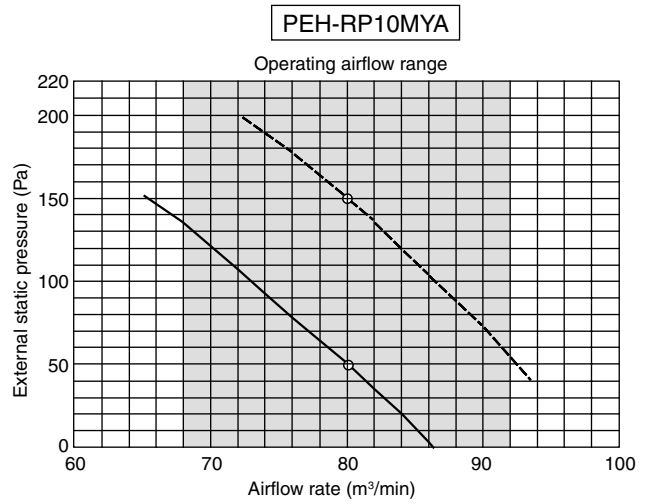
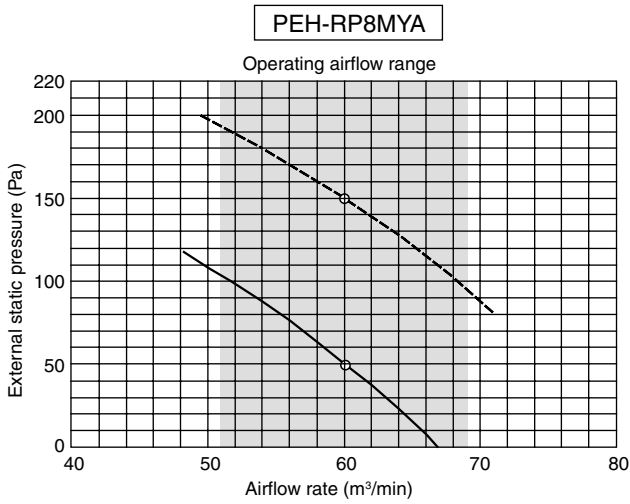

[5] Center of Gravity (Indoor unit)

- Models PEH-RP8MYA/RP10MYA

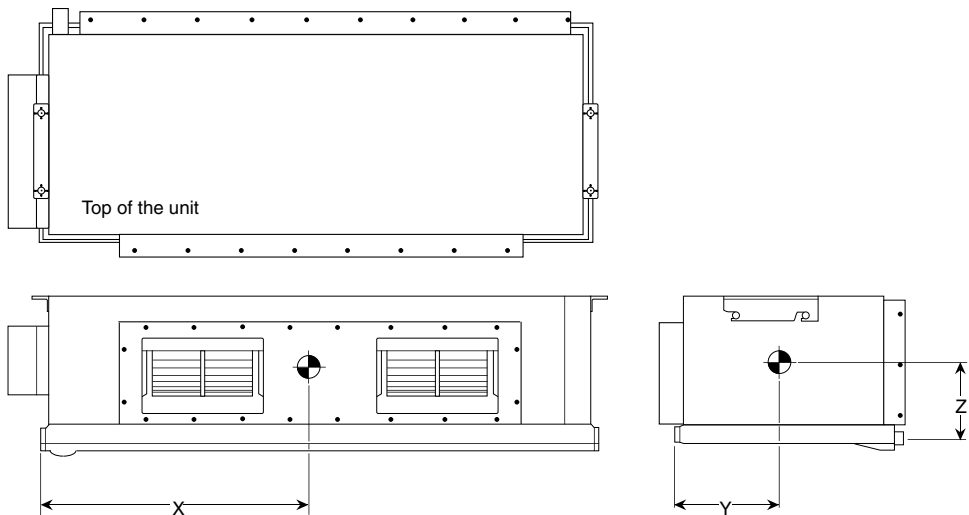

unit : (mm)

Item	Center of gravity		
	X	Y	Z
Model name			
PEH-RP8MYA	630	230	240
PEH-RP10MYA	730	235	240

[6] Standard Operation Data

Service Ref.			PEH-RP8MYA		PEH-RP10MYA			
Mode			Cooling	Heating	Cooling	Heating		
Electrical circuit	Indoor unit Service Ref.		PEH-RP8MYA		PEH-RP10MYA			
	Phase, Hz		3, 50		3, 50			
	Volts	V	400		400			
	Input	kW	0.65		0.94			
	Current	A	1.12		1.64			
	Outdoor unit Service Ref.		PUHZ-RP8YHA		PUHZ-RP10YHA			
	Phase, Hz		3, 50		3, 50			
	Volts	V	400		400			
Refrigerant circuit	Current		A	10.63	10.15	12.01	11.98	
	Discharge pressure		MPa (kgf/cm ²)	2.81 (28.7)	2.59 (26.4)	2.86 (29.2)	2.27 (23.2)	
	Suction pressure		MPa (kgf/cm ²)	0.92 (9.4)	0.69 (7.0)	0.96 (9.8)	0.63 (6.4)	
	Discharge temreature		°C	73.0	71.3	70.2	67.1	
	Condensing temreature		°C	47.1	41.4	47.8	38.7	
	Suction temreature		°C	12.2	4.7	14.6	3.0	
Ref. pipe length		m	5	5	5	5		
Indoor side	Intake air temreature		D.B.	°C	27	20	27	20
			W.B.	°C	19	15	19	15
	Discharge air temreature		D.B.	°C	14.7	38.8	15.3	37.0
Outdoor side	Intake air temreature		D.B.	°C	35	7	35	7
			W.B.	°C	24	6	24	6
SHF				0.75	–	0.82	–	
BF				0.18	–	0.15	–	

The unit of pressure has been changed to MPa based on international SI system.
The conversion factor is : 1(MPa)=10.2(kgf/cm²)

[7] NC Curve (Indoor unit)

PEH-RP8MYA

Measurement condition

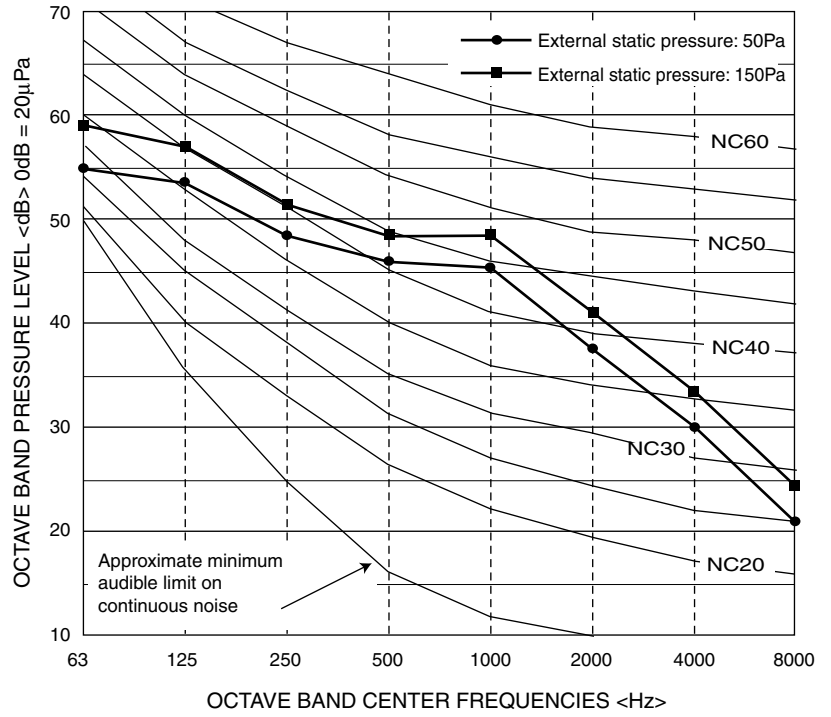
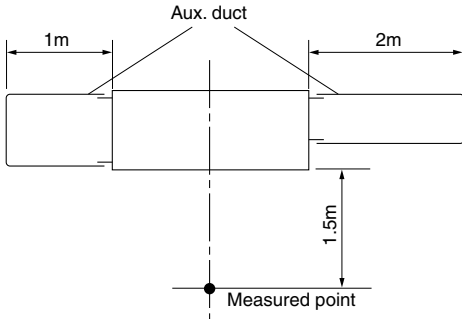

PEH-RP10MYA

Measurement condition

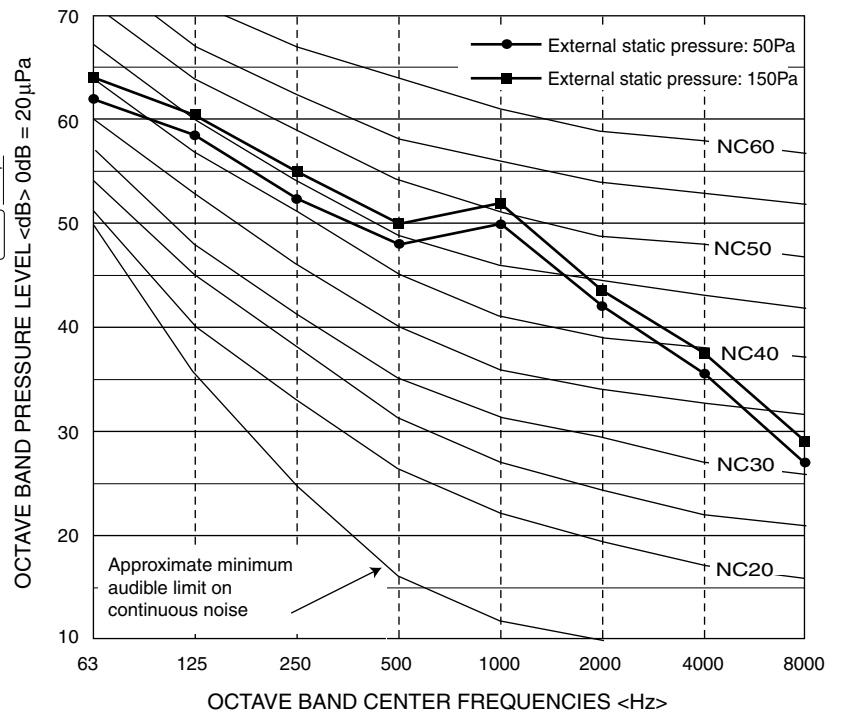
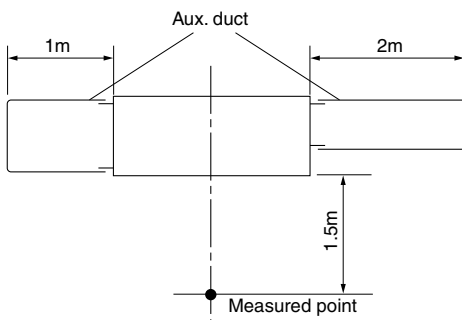

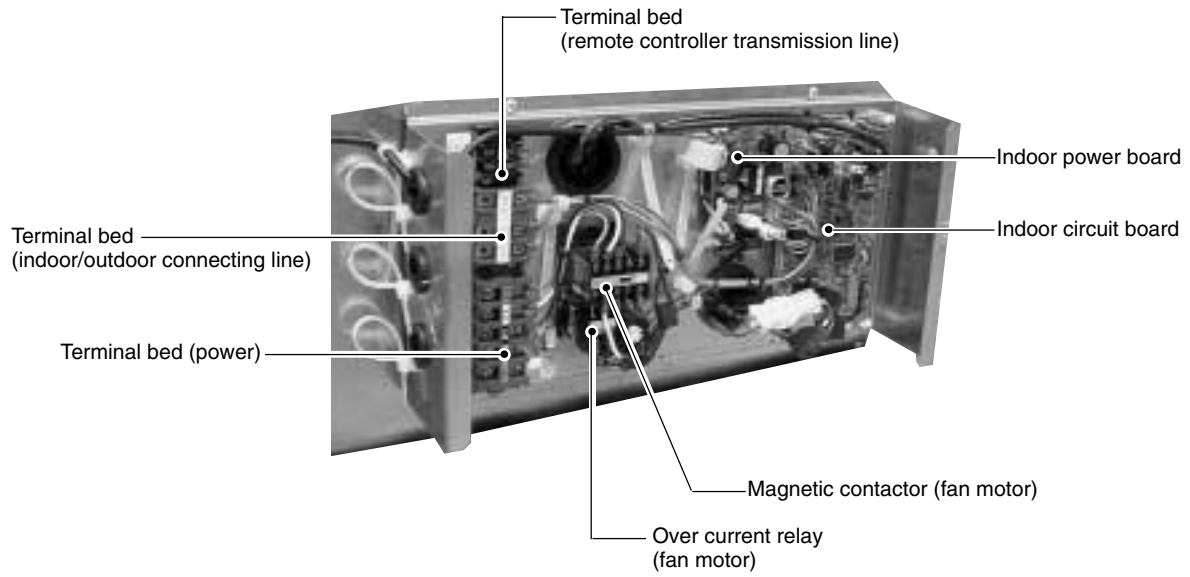
[1] Appearance of Equipment**• PEH-RP8MYA/RP10MYA Electrical Parts Box (with cover removed)**

[2] Internal Construction

• PEH-RP8MYA/RP10MYA (Indoor unit)

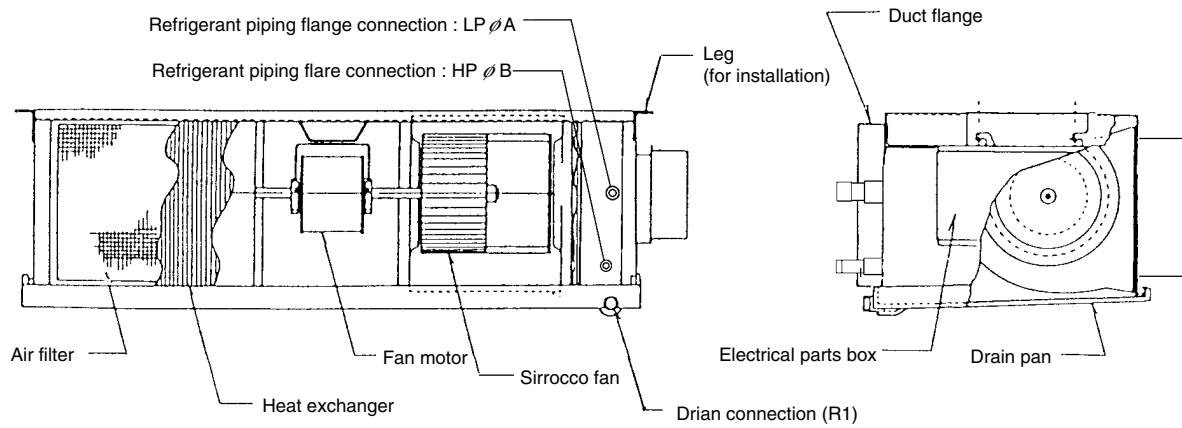

Model name	A	B
PEH-RP8MYA	25.4	9.52
PEH-RP10MYA	28.58	12.7

[3] Refrigerant Circuit

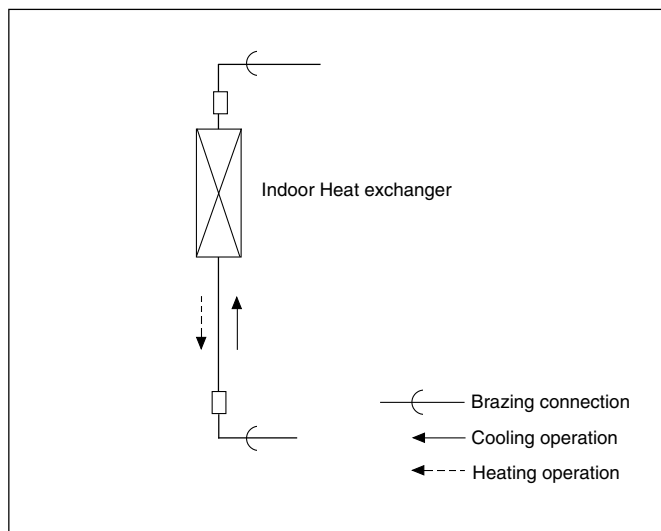

8 FUNCTION OF SWITCH ON INDOOR CIRCUIT BOARD

[1] DIP SW1 for model Selection (DIP SW1 has been set at factory)



OFF
PEH-RP8MYA/RP10MYA : SW1-1, -4 ON, SW1-2, -3, -5 OFF

[2] DIP SW2 for Capacity Setting (DIP SW2 has been set at factory)



OFF
PEH-RP8MYA : SW2-1, -2, -3 and, -4 OFF

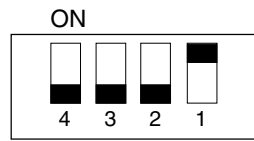

OFF
PEH-RP10MYA : SW2-1 ON, SW2-2, -3, and, -4 OFF

[3] DIP SWE for Emergency Operation

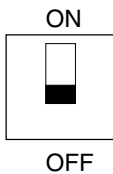

When SWE is turned ON, FAN turns ON. Setting of emergency operation other than SWE is performed at the outdoor unit. For a description of the specific emergency operation execution method, refer to the outdoor unit (PUHZ-RP8YHA, PUHZ-RP10YHA) Technical & Service Manual.

[1] Before test run

The test run can be carried out either from the outdoor unit or the indoor unit.

1. Check list

- After the installation, piping setup, and wiring of the indoor and outdoor units is complete, check that refrigerant is not leaking, the power and control wires are not loose, and the poles are not reversed.
 - Use a 500 V insulation resistance tester to make sure that the resistance between the power terminal and the ground is 1.0 M or more. If it is less than 1.0 M, do not operate the unit. *Absolutely do not touch the tester to indoor/outdoor connection terminals S1, S2, and S3. An accident could occur.
 - Make sure there is no malfunction in the outdoor unit. (If there is a malfunction, you can diagnose it using LED2 on the board.)
 - Check that the ball valve is fully open on both the liquid and gas ends.
 - Check the electrical power phase. If the phase is reversed, the fan may rotate in the wrong direction or stop, or unusual sounds may be produced.
 - Starting at least 12 hours before the test run, send current through the crankcase heater. (If the current is running for a shorter period of time, damage to the compressor could result.)
 - For specific models requiring changing of settings for higher ceilings or selection of power supply ON/OFF capability, make proper changes referring to the description for Selection of Functions through Remote Controller.
- After the above checks are complete, carry out the test run as indicated in the following outline.

[2] Test run procedures

1. Indoor unit

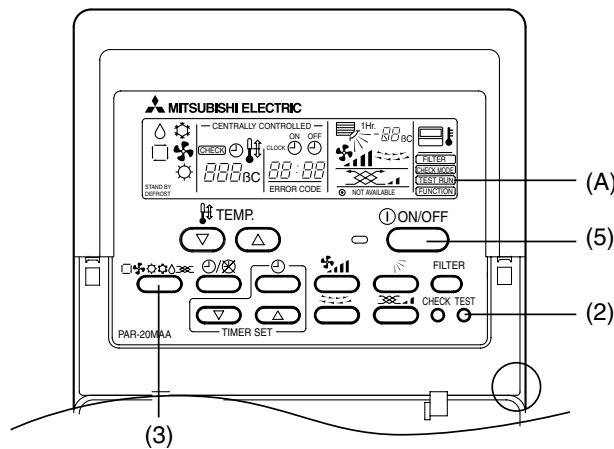

Operating procedures

- Turn on the main power supply

While the room temperature display on the remote controller reads “CENTRALLY CONTROLLED”, the remote controller is disabled. Turn off the “CENTRALLY CONTROLLED” display before using the remote controller.
- Press “TEST RUN” button twice



(A) The ‘TEST RUN’ indicator should light up.
- Press button

Cooling/drying mode : Cool air should start to blow.
Heating mode : Warm air should start to blow (after a while).
- Check the outdoor unit fan for correct running

The outdoor unit features automatic capacity control to provide optimum fan speeds. The fan keeps running at a low speed to meet the current outside air condition unless it exceeds its available maximum power. Then, in actuality, the fan may stop or run in the reverse direction depending on the outside air, which does not mean malfunction.
- Press the “ON/OFF” button to reset the test run in progress
 - The test run will be automatically shut down after two hours in response to the AUTO STOP setting of two hours on the timer.
 - During the test run, the room temperature display shows the indoor unit tubing temperatures.

- In the case of the test run, the OFF timer will activate, and the test run will automatically stop after two hours.
 - The room temperature display section shows the control temperature for the indoor units during the test run.
 - Check that all the indoor units are running properly for simultaneous twin and triple operation.
- Malfunions may not be displayed even if the wiring is incorrect.

(*1)

After turning ON the power, the system will go into startup mode, and the remote controller operation lamp (red) and the room temperature display section's "H0" will flash. Also, in the case of the indoor substrate LEDs, LED 1 and LED 2 light up (when address is 0) or become dim (when address is not 0), and LED 3 flashes. In the case of the outdoor substrate LED display,  and  are displayed alternatively at 1-second intervals.

- If one of the above operations does not function correctly, the following causes should be considered, and if applicable, dealt with. (The following symptoms have been determined under test run mode. Note that "startup" in the chart means the *1 display above.)

Symptoms		Cause
Remote Controller Display	Outdoor Substrate LED Display	
Remote controller is displaying "H0", and operation is not possible.	After "startup" display, "00" is displayed (correct operation).	• After power is turned ON, system startup lasts for about 2 mins., and "H0" is displayed (correct operation).
After power is turned ON, "H0" is displayed for 3 mins., then error code is displayed.	After "startup" display, error code is displayed.	• Outdoor unit's safeguard installation connector is open. • Negative phase and open phase of outdoor unit's power terminal board. (Single phase: L, N, ⊕/triple phase: L1, L2, L3, N, ⊕)
	After "startup" display, "F1" (negative phase) is displayed.	• Incorrect connection of outdoor terminal board (Single phase: L, N, ⊕/triple phase: L1, L2, L3, N, ⊕ grounding and S1, S2, S3)
Power is turned ON, and "EE" or "EF" are displayed after "H0" is displayed.	After "startup" display, "00" or "EE" is displayed ("EE" is displayed when a test run is made).	• Outdoor unit and indoor unit construction differ.
Display messages do not appear even when remote controller operation switch is turned ON (operation lamp does not light up).	After "startup" display, "EA" (error for number of units) or "Eb" (unit number error) is displayed.	• Wiring for the indoor and outdoor unit is not connected correctly. (Polarity is wrong for S1, S2, S3) • Remote controller transmission wire short.
	After "startup" display, "00" is displayed (correct operation).	• There is no outdoor unit for address 0 (address is something other than 0).
	After "startup" display, "00" is displayed (correct operation).	• Remote controller transmission wire burnout.
Operation display appears but soon disappears even when remote controller operations are executed.	After "startup" display, "00" is displayed (correct operation).	• After cancellation of function selection, operation is not possible for about 30 secs. (correct operation).

* Press the remote controller's "CHECK" button twice consecutively to be able to run a self diagnosis. See the chart below for content of error code displays.

LCD	Nonconformity content	LCD	Nonconformity content	LCD	Nonconformity content
P1	Suction sensor error	P8	Tube temperature error	E6 ~ EF	Signal error between indoor and outdoor units
P2	Tubing (liquid) sensor error	P9	Tube (2-phase tube) sensor error		
P4	Drain sensor error	U0 ~ UP	Outdoor unit nonconformity	----	No error history
P5	Drain overflow safeguard operation	F1 ~ FA	Outdoor unit nonconformity	FFFF	No relevant unit
P6	Freezing/overheating safeguard operation	E0 ~ E5	Signal error between remote controller and indoor unit		

See the chart below for details of the LED displays (LED 1, 2, 3) on the indoor substrate.

LED 1 (microcomputer power supply)	Displays the ON/OFF of power for control. Check that this is lit during normal use.
LED 2 (remote controller feed)	Displays the ON/OFF of feed to wired remote controller. Is only lit for indoor unit linked to outdoor unit with address "00".
LED 3 (indoor and outdoor signals)	Displays signal between indoor and outdoor units. Check that this is flashing during normal use.

2. Outdoor unit

(1) Check Items

- After installation of indoor and outdoor units, and piping and electric wiring work, check that the unit is free from leaks of refrigerant, loosened connections, and incorrect polarity.
- Check that there is no negative phase and open phase. (The F1 message for negative phase and the F2 message for open phase will flash at LED 1 on the outdoor substrate. If this happens, rewire correctly.)
- Measure the impedance between power terminals (Single phase: L, N, ⊕/triple phase: L1, L2, L3, N, ⊕) and the ground with a 500 V Megger and check that it is 1.0 M or more. Do not operate the equipment if measurement is less than 1.0 M. *Never conduct this operation on the outdoor connection wiring terminals (S1, S2, S3) as this causes damage.

- When there is no error at the outdoor unit. (If there is an error at the outdoor unit, it can be evaluated at LED 1 [digital display] of the outdoor substrate.)
- The stop valves are open both the liquid and gas sides.
After checking the above, execute the test run in accordance with the following.

(2) Test run start and finish

- Operation from the indoor unit
Execute the test run using the installation manual for the indoor unit.
- Operation from the outdoor unit
Execute settings for test run start, finish and operation mode (cooling, heating) using the DIP switch SW 4 on the outdoor substrate.

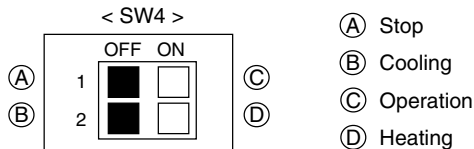

- Set the operation mode (cooling, heating) using SW 4-2
 - Turn ON SW 4-1, The operation mode for SW 4-2 will be adhered to, and the test run will commence
 - Turn OFF SW 4-1 to finish the test run
- There may be a faint knocking noise emitted from the proximity of the fan during the test run. This is torque fluctuation occurring due to control of fan revolutions. There is no problem with the product.

Note:

The SW 4-2 operation mode cannot be changed during the test run. (To change test run mode, stop the equipment with SW 4-1, change the operation mode, then restart test run with SW 4-1.)

- If the 2-hour timer is set, the test run will stop automatically after 2 hours.
- During the test run, the room temperature display on the indoor unit will indicate the temperature of the indoor unit piping.

[3] Self-diagnosis

Use the remote controller to look up each units error history.

1.

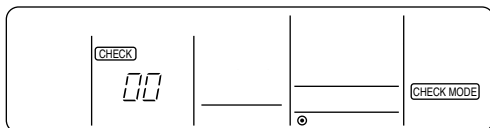

2.

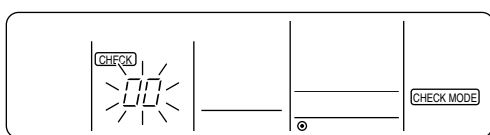

3. (1)

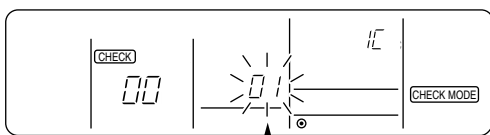
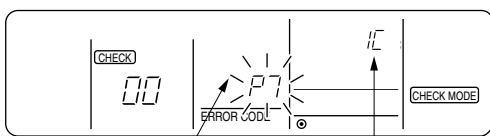

1. Change to self-diagnosis mode

Press the CHECK button twice within three seconds to show the following

2. Select the refrigerant address number to be self-diagnosed

Press the buttons to scroll through the refrigerant address numbers (00 to 15) and select the refrigerant address number to be self-diagnosed.

After three seconds from making the change, the lit refrigerant address to be self-diagnosed will start to flash, and self-diagnosis will commence.

3. Self-diagnosis result display

See the above chart for details of error code contents.

(1) When there is an error history

- Alternating display
- Error code
- Attribute of error search
- Unit number

3. (2)

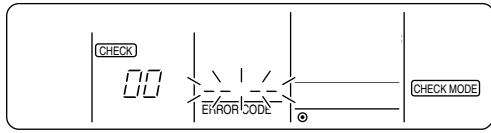

(3)

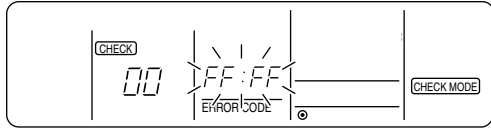

4.

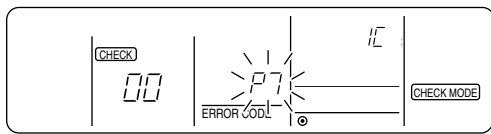

↓↑ a)

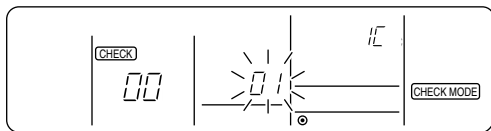

5.

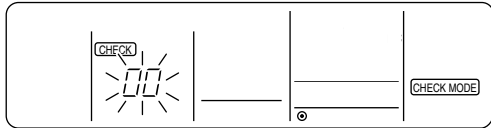

↓

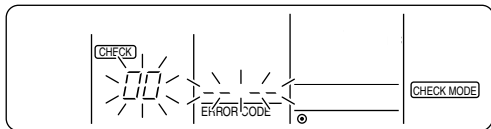

(2) When there is no error history

(3) When the address does not exist

4. Reset error history

Display the error history at the self-diagnosis result display screen 3.

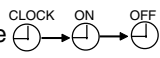
The address for self-diagnosis will flash when the  button is pressed twice within three seconds.

The diagram on the left will be displayed when error history has been reset.

Note that the error content will be redisplayed if error history resetting is unsuccessful.

a) Alternating display

5. Canceling self-diagnosis

The following two methods can be used to cancel self-diagnosis. Press the CHECK button twice within three seconds to cancel self-diagnosis. The display screen will return to the status before self-diagnosis. Press the 1 ON/OFF button to cancel self-diagnosis. The indoor unit will stop. (This operation is ineffectual when operation is prohibited.)

[4] Remote controller diagnosis

If operation cannot be carried out from the remote controller, use this function to diagnose the remote controller.

1.

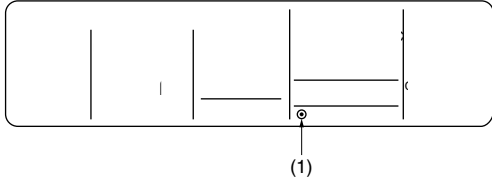

1. First, check the electricity current marker

If the correct voltage (DC 12 V) is not displayed on the remote controller, the electric current marker will be lit. If the electricity current marker is not lit, check the remote controller wiring and the indoor unit.

(1) Electric current marker

2.

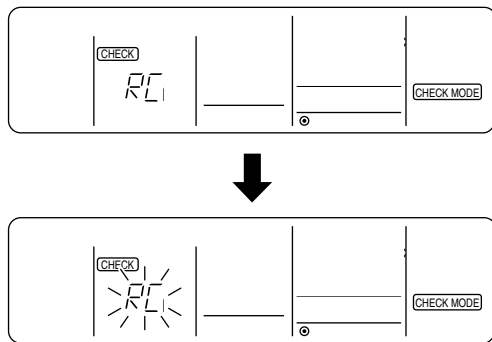

2. Transfer to remote control mode

Hold down the CHECK button for five seconds or more to display the diagram on the left.

Press the FILTER button to commence diagnosis of remote controller.

3. (1)

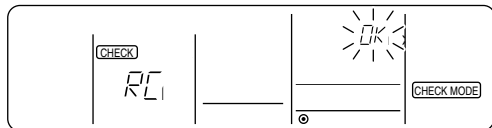

3. Remote controller diagnosis results

(1) The remote control is functioning correctly.

Check other possible causes as there are no problems with the remote controller.

(2)

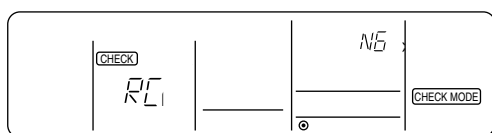

(2) The remote controller has a nonconformity.

The remote controller must be replaced. Error display 1 ("NG") flashes to show a nonconformity in the transmitter-receiver circuit.

Potential problems other than those diagnosed for the remote controller.

(1)

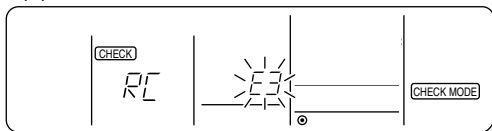

(1) Single transmission not possible if error display 2 ("E3") flashes.

There is "noise" on the transmission line, or damage of other remote controllers for the indoor units can be considered. Check the transmission path and other controllers.

(2)

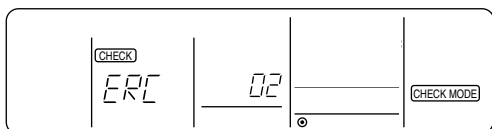

(2) Data error has occurred when error display three shows "ERC" and number of data errors.

Number of generated data errors (maximum 66 errors). The number of generated data errors stands for the difference in the number of bits of transmitted data from the remote controller and the actual number of bits that were transmitted along the transmission path. If this error occurs, "noise", etc., is interfering with the transmission data. Check the transmission path.

K) When the number of data errors generated is 02

L) Remote controller transmission data

M) Transmission data at transmission path

4. Cancel the remote controller diagnosis

Hold down the CHECK button for five seconds or more to cancel the remote controller diagnosis. The "HO" operation lamp will flash, and the display screen will return to the status before remote controller diagnosis in approximately 30 seconds.

— MEMO —



Certificate Number FM33568

The Air Conditioning & Refrigeration Systems Works acquired ISO 9001 certification under Series 9000 of the International Standard Organization (ISO) based on a review of quality warranties for the production of refrigeration and air conditioning equipment.

ISO Authorization System

The ISO 9000 series is a plant authorization system relating to quality warranties as stipulated by the ISO. ISO 9001 certifies quality warranties based on the "design, development, production, installation and auxiliary services" for products built at an authorized plant.



Certificate Number EC97J1227
Registered on March 10, 1998

The Air Conditioning & Refrigeration Systems Works acquired environmental management system standard ISO 14001 certification.

The ISO 14000 series is a set of standards applying to environmental protection set by the International Standard Organization (ISO). ISO 14001 certifies the plant's environmental protection system and activities.



HEAD OFFICE: MITSUBISHI DENKI BLDG., 2-2-3, MARUNOUCHI, CHIYODA-KU, TOKYO 100-8310, JAPAN