

# Air-Conditioners PUHZ-RP8,10 YHA

## INSTALLATION MANUAL

**FOR INSTALLER**

For safe and correct use, please read this installation manual thoroughly before installing the air-conditioner unit.

## INSTALLATIONSHANDBUCH

**FÜR INSTALLATEURE**

Zum sicheren und ordnungsgemäßen Gebrauch der Klimaanlage das Installationshandbuch gründlich durchlesen.

## MANUEL D'INSTALLATION

**POUR L'INSTALLATEUR**

Veuillez lire le manuel d'installation en entier avant d'installer ce climatiseur pour éviter tout accident et vous assurer d'une utilisation correcte.

## INSTALLATIEHANDLEIDING

**VOOR DE INSTALLATEUR**

Voor een veilig en juist gebruik moet u deze installatiehandleiding grondig doorlezen voordat u de airconditioner installeert.

## MANUAL DE INSTALACIÓN

**PARA EL INSTALADOR**

Para un uso seguro y correcto, lea detalladamente este manual de instalación antes de montar la unidad de aire acondicionado.

## MANUALE DI INSTALLAZIONE

**PER L'INSTALLATORE**

Per un uso sicuro e corretto, leggere attentamente questo manuale di installazione prima di installare il condizionatore d'aria.

## ΕΓΧΕΙΡΙΔΙΟ ΟΔΗΓΙΩΝ ΕΓΚΑΤΑΣΤΑΣΗΣ

**ΓΙΑ ΑΥΤΟΝ ΠΟΥ ΚΑΝΕΙ ΤΗΝ ΕΓΚΑΤΑΣΤΑΣΗ**

Για ασφάλεια και σωστή χρήση, παρακαλείστε διαβάσετε προσεκτικά αυτό το εγχειρίδιο εγκατάστασης πριν αρχίσετε την εγκατάσταση της μονάδας κλιματισμού.

## MANUAL DE INSTALAÇÃO

**PARA O INSTALADOR**

Para segurança e utilização correctas, leia atentamente este manual de instalação antes de instalar a unidade de ar condicionado.

## INSTALLATIONSMANUAL

**TIL INSTALLATØREN**

Læs venligst denne installationsmanual grundigt, før De installerer airconditionanlægget, af hensyn til sikker og korrekt anvendelse.

## INSTALLATIONSMANUAL

**FÖR INSTALLATÖREN**

Läs denna installationsmanual noga för säkert och korrekt bruk innan luftkonditioneringen installeras.

## MONTAJ ELKİTABI

**MONTÖR İÇİN**

Emniyetli ve doğru biçimde nasıl kullanılacağını öğrenmek için lütfen klima cihazını monte etmeden önce bu elkitabını dikkatle okuyunuz.

## РУКОВОДСТВО ПО УСТАНОВКЕ

**ДЛЯ УСТАНОВИТЕЛЯ**

Для осторожного и правильного использования прибора необходимо тщательно ознакомиться с данным руководством по установке до выполнения установки кондиционера.

English

Deutsch

Français

Nederlands

Español

Italiano

Ελληνικά

Português

Dansk

Svenska

Türkçe

Русский

# Contents

1. Safety precautions .....	2	7. Electrical work .....	11
2. Installation location .....	3	8. Test run .....	12
3. Transporting the unit .....	5	9. Special Functions .....	13
4. Installing the outdoor unit .....	6	10. System controll (Fig. 10-1) .....	13
5. Installing the refrigerant piping .....	7	11. Information on rating plate .....	13
6. Drainage piping work .....	11		

## 1. Safety precautions

- ▶ Before installing the unit, make sure you read all the "Safety precautions".
- ▶ This equipment does not comply with the relevant technical standard for the limitation of flicker and this may cause adverse effects on other electrical appliances. Please provide an exclusive circuit for the air conditioner and ensure, the max. impedance in this manual. Do not connect other appliances to this circuit.
- ▶ Please report to or take consent by the supply authority before connection to the system.

### ⚠ Warning:

Describes precautions that must be observed to prevent danger of injury or death to the user.

### ⚠ Caution:

Describes precautions that must be observed to prevent damage to the unit.

After installation work has been completed, explain the "Safety Precautions," use, and maintenance of the unit to the customer according to the information in the Operation Manual and perform the test run to ensure normal operation. Both the Installation Manual and Operation Manual must be given to the user for keeping. These manuals must be passed on to subsequent users.

### ⚠ Warning:

- The unit must not be installed by the user. Ask a dealer or an authorized technician to install the unit. If the unit is installed incorrectly, water leakage, electric shock, or fire may result.
- For installation work, follow the instructions in the Installation Manual and use tools and pipe components specifically made for use with R410A refrigerant. The R410A refrigerant in the HFC system is pressurized 1.6 times the pressure of usual refrigerants. If pipe components not designed for R410A refrigerant are used and the unit is not installed correctly, the pipes may burst and cause damage or injuries. In addition, water leakage, electric shock, or fire may result.
- The unit must be installed according to the instructions in order to minimize the risk of damage from earthquakes, typhoons, or strong winds. An incorrectly installed unit may fall down and cause damage or injuries.
- The unit must be securely installed on a structure that can sustain its weight. If the unit is mounted on an unstable structure, it may fall down and cause damage or injuries.
- If the air conditioner is installed in a small room, measures must be taken to prevent the refrigerant concentration in the room from exceeding the safety limit in the event of refrigerant leakage. Consult a dealer regarding the appropriate measures to prevent the allowable concentration from being exceeded. Should the refrigerant leak and cause the concentration limit to be exceeded, hazards due to lack of oxygen in the room may result.
- Ventilate the room if refrigerant leaks during operation. If refrigerant comes into contact with a flame, poisonous gases will be released.
- All electric work must be performed by a qualified technician according to local regulations and the instructions given in this manual. The units must be powered by dedicated power lines and the correct voltage and circuit breakers must be used. Power lines with insufficient capacity or incorrect electrical work may result in electric shock or fire.

### 1.1. Before installation

#### ⚠ Caution:

- Do not use the unit in an unusual environment. If the air conditioner is installed in areas exposed to steam, volatile oil (including machine oil), or sulfuric gas, areas exposed to high salt content such as the seaside, or areas where the unit will be covered by snow, the performance can be significantly reduced and the internal parts can be damaged.
- Do not install the unit where combustible gases may leak, be produced, flow, or accumulate. If combustible gas accumulates around the unit, fire or explosion may result.
- The outdoor unit produces condensation during the heating operation. Make sure to provide drainage around the outdoor unit if such condensation is likely to cause damage.

### 1.2. Before installation (relocation)

#### ⚠ Caution:

- Be extremely careful when transporting the units. Please read and fully understand "3. Transporting the unit" before transporting the unit. Wear protective gloves to remove the unit from the packaging and to move it, as you can injure your hands on the fins or other parts.
- Be sure to safely dispose of the packaging materials. Packaging materials, such as nails and other metal or wooden parts may cause stabs or other injuries.

⊘ : Indicates an action that must be avoided.

⚠ : Indicates that important instructions must be followed.

⚡ : Indicates a part which must be grounded.

⚠ : Indicates that caution should be taken with rotating parts.

⚡ : Indicates that the main switch must be turned off before servicing.

⚠ : Beware of electric shock.

⚠ : Beware of hot surface.

⚡ ELV: At servicing, please shut down the power supply for both the Indoor and Outdoor Unit.

### ⚠ Warning:

Carefully read the labels affixed to the main unit.

- Use C1220 copper phosphorus, for copper and copper alloy seamless pipes, to connect the refrigerant pipes. If the pipes are not connected correctly, the unit will not be properly grounded and electric shock may result.
- Use only specified cables for wiring. The connections must be made securely without tension on the terminals. If the cables are connected or installed incorrectly, overheating or fire may result.
- The terminal block cover panel of the outdoor unit must be firmly attached. If the cover panel is mounted incorrectly and dust and moisture enter the unit, electric shock or fire may result.
- When installing or moving the air conditioner, use only the specified refrigerant (R410A) to charge the refrigerant lines. Do not mix it with any other refrigerant and do not allow air to remain in the lines. Air enclosed in the lines can cause pressure peaks resulting in a rupture and other hazards.
- Use only accessories authorized by Mitsubishi Electric and ask a dealer or an authorized technician to install them. If accessories are incorrectly installed, water leakage, electric shock, or fire may result.
- Do not alter the unit. Consult a dealer for repairs. If alterations or repairs are not performed correctly, water leakage, electric shock, or fire may result.
- The user should never attempt to repair the unit or transfer it to another location. If the unit is installed incorrectly, water leakage, electric shock, or fire may result. If the air conditioner must be repaired or moved, ask a dealer or an authorized technician.
- After installation has been completed, check for refrigerant leaks. If refrigerant leaks into the room and comes into contact with the flame of a heater or portable cooking range, poisonous gases will be released.

- When installing the unit in a hospital or communications office, be prepared for noise and electronic interference. Inverters, home appliances, high-frequency medical equipment, and radio communications equipment can cause the air conditioner to malfunction or breakdown. The air conditioner may also affect medical equipment, disturbing medical care, and communications equipment, harming the screen display quality.

- The base and attachments of the outdoor unit must be periodically checked for looseness, cracks or other damage. If such defects are left uncorrected, the unit may fall down and cause damage or injuries.
- Do not clean the air conditioner unit with water. Electric shock may result.
- Tighten all flare nuts to specification using a torque wrench. If tightened too much, the flare nut can break after an extended period and refrigerant can leak out.

# 1. Safety precautions

## 1.3. Before electric work

⚠ Caution:

- Be sure to install circuit breakers. If not installed, electric shock may result.
- For the power lines, use standard cables of sufficient capacity. Otherwise, a short circuit, overheating, or fire may result.
- When installing the power lines, do not apply tension to the cables. If the connections are loosened, the cables can snap or break and overheating or fire may result.
- Be sure to ground the unit. Do not connect the ground wire to gas or water pipes, lighting rods, or telephone grounding lines. If the unit is not properly grounded, electric shock may result.
- Use circuit breakers (ground fault interrupter, isolating switch (+B fuse), and molded case circuit breaker) with the specified capacity. If the circuit breaker capacity is larger than the specified capacity, breakdown or fire may result.

## 1.4. Before starting the test run

⚠ Caution:

- Before starting operation, check that all panels, guards and other protective parts are correctly installed. Rotating, hot, or high voltage parts can cause injuries.
- Do not touch any switch with wet hands. Electric shock may result.
- Do not touch the refrigerant pipes with bare hands during operation. The refrigerant pipes are hot or cold depending on the condition of the flowing refrigerant. If you touch the pipes, burns or frostbite may result.
- After stopping operation, be sure to wait at least five minutes before turning off the main power switch. Otherwise, water leakage or breakdown may result.

## 1.5. Using R410A refrigerant air conditioners

⚠ Caution:

- Use C1220 copper phosphorus, for copper and copper alloy seamless pipes, to connect the refrigerant pipes. Make sure the insides of the pipes are clean and do not contain any harmful contaminants such as sulfuric compounds, oxidants, debris, or dust. Use pipes with the specified thickness. (Refer to page 7) Note the following if reusing existing pipes that carried R22 refrigerant.
- Do not use OL material for the  $\phi 22.2$  pipes.
  - Replace the existing flare nuts and flare the flared sections again.
  - Do not use thin pipes. (Refer to page 7)
- Store the pipes to be used during installation indoors and keep both ends of the pipes sealed until just before brazing. (Leave elbow joints, etc. in their packaging.) If dust, debris, or moisture enters the refrigerant lines, oil deterioration or compressor breakdown may result.
- Use ester oil, ether oil, alkylbenzene oil (small amount) as the refrigeration oil applied to the flared sections. If mineral oil is mixed in the refrigeration oil, oil deterioration may result.
- Do not use refrigerant other than R410A refrigerant. If another refrigerant is used, the chlorine will cause the oil to deteriorate.
- Use the following tools specifically designed for use with R410A refrigerant. The following tools are necessary to use R410A refrigerant. Contact your nearest dealer for any questions.

Tools (for R410A)	
Gauge manifold	Flare tool
Charge hose	Size adjustment gauge
Gas leak detector	Vacuum pump adapter
Torque wrench	Electronic refrigerant charging scale
Safety chager	



Fig. 1-1

## 1.6. Accessories of outdoor unit (Fig. 1-1)

The parts show in the left are the accessories of this unit, which are affixed to the inside of the service panel.

- ① Flange joint ... x1
- ② Packing ..... x1

# 2. Installation location

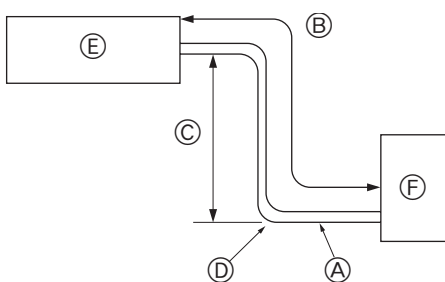

Fig. 2-1

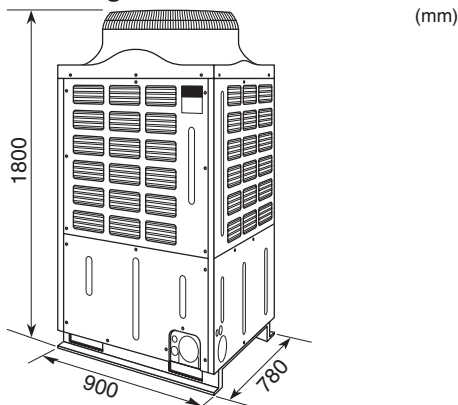

Fig. 2-2

## 2.1. Refrigerant pipe (Fig. 2-1)

► Check that the difference between the heights of the indoor and outdoor units, the length of refrigerant pipe, and the number of bends in the pipe are within the limits shown below.

Models	A Pipe size (mm)		B Pipe length (one way)	C Height difference	D Number of bends (one way)
	Gas side	Liquid side			
RP8	$\phi 25.4$	$\phi 9.52$	Max. 80 m	Max. 40 m	Max. of 15
RP10	$\phi 28.58$	$\phi 12.7$	Max. 80 m	Max. 40 m	Max. of 15

- Height difference limitations are binding regardless of which unit, indoor or outdoor, is positioned higher.
  - Ⓔ Indoor unit
  - Ⓕ Outdoor unit

## 2.2. Choosing the outdoor unit installation location

- Avoid locations exposed to direct sunlight or other sources of heat.
- Select a location from which noise emitted by the unit will not inconvenience neighbors.
- Avoid locations where the unit will be exposed to strong winds.
- Select a location permitting easy wiring and pipe access to the power source and indoor unit.
- Avoid locations where combustible gases may leak, be produced, flow, or accumulate.
- Note that water may drain from the unit during operation.
- Select a level location that can bear the weight and vibration of the unit.
- Avoid locations where the unit can be covered by snow. In areas where heavy snow fall is anticipated, special precautions such as raising the installation location or installing a hood on the air intake and air outlet must be taken to prevent the snow from blocking the air intake or blowing directly against it. This can reduce the airflow and a malfunction may result.
- Avoid locations exposed to oil, steam, or sulfuric gas.

## 2.3. Outline dimensions (Outdoor unit) (Fig. 2-2)



## 2. Installation location

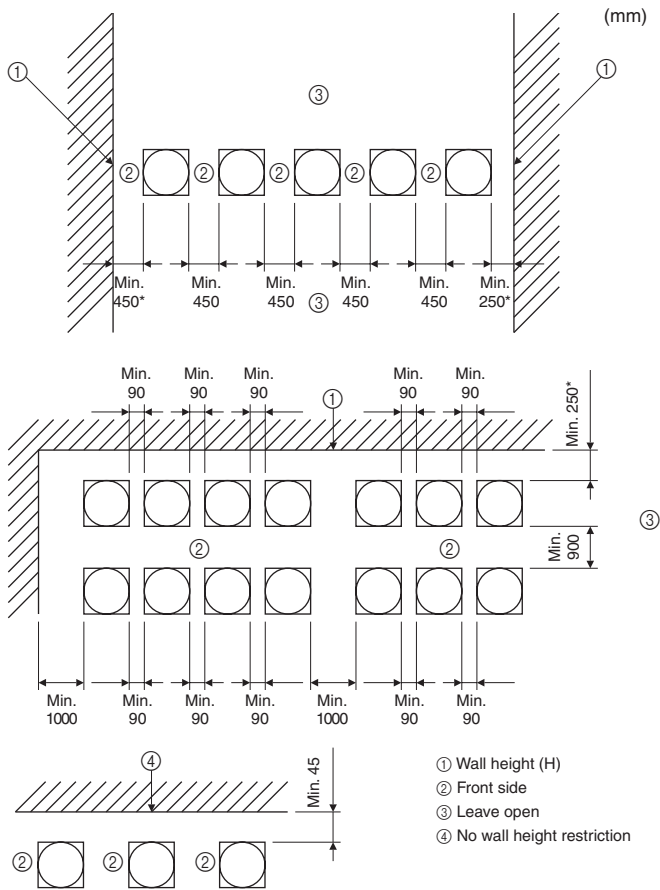

- Leave open in two directions.
- If the wall height (H) exceeds the overall height of the unit, add the dimension shown as "h" to the dimension shown as "450\*": (h: Wall height (H) - overall unit height)
- When there is a wall in front of the units, limit the maximum number of units connected together to 4 and allow 1,000 mm of space or more between every 4 units to provide space for airflow and space for people to pass through.

Fig. 2-8

## 3. Transporting the unit

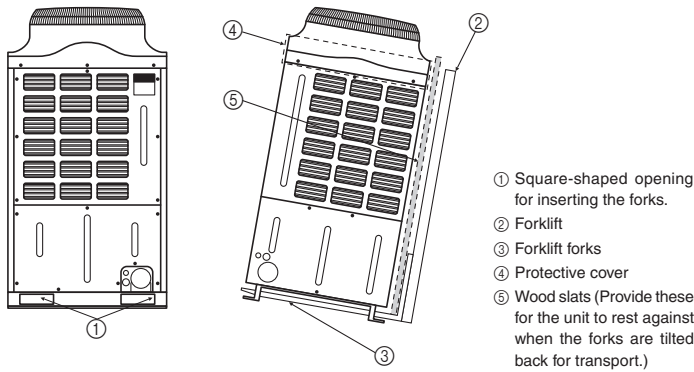

Fig. 3-1

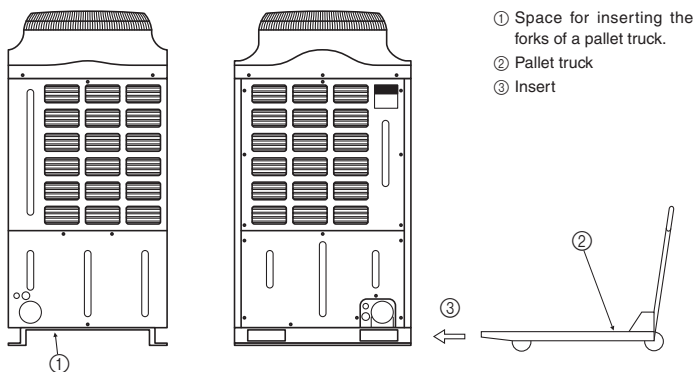

Fig. 3-2

### Use care in the following areas when handling the units.

When using a forklift or similar equipment to load or unload the units, always insert the forks of the forklift into the square-shaped openings provided (as shown in the illustration on the left) and transport. It is dangerous to insert the forks from the side as the unit has a center of gravity that is not at the center of the unit. It may tilt away from its center of gravity and become unstable.

### 3.1. Transporting by forklift (Fig. 3-1)

- When transporting the unit by forklift, always insert the forks into the square-shaped openings at the base of the unit.

#### Note:

1. Always use care when transporting a unit by forklift on rainy days as slip-page can occur.
2. Never use dangerous sudden movements, such as accelerating or applying the brakes suddenly or turning the steering wheel quickly, when transporting the unit by forklift.

### 3.2. Transporting by pallet truck (Fig. 3-2)

- When using a pallet truck to transport the unit, insert the forks from the side of the unit.

#### Note:

The center of gravity of the unit is not at the dimensional center of the unit. Therefore, make sure that the forks of the pallet truck pass completely under the unit and extend out the opposite side before lifting the unit for transport.

### 3. Transporting the unit

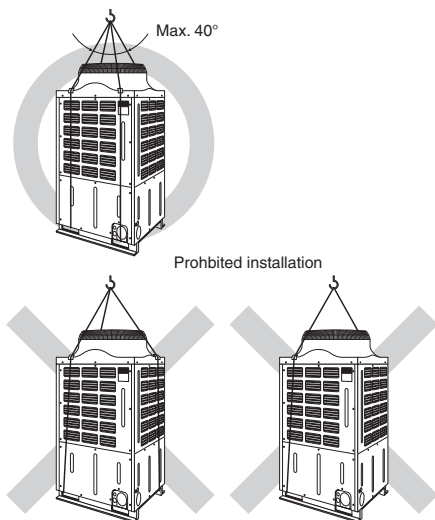

Fig. 3-3

#### 3.3. Precautions when lifting the unit (Fig. 3-3)

- When hang-lifting the unit, pass the sling or rope through the square-shaped holes at the base and through the lifting hooks at the front and rear of the top.
- Always pass the sling or rope through the four lifting hooks on the top of the unit. Use care not to jolt or expose the unit to impact.
- Make sure that the lifting angle of the rope or sling is 40° or less.
- Use two slings or ropes for lifting. Make sure that the rope or sling is 7 meters long or longer and can withstand the weight of the unit.
- Place some form of padding between the unit and the rope or sling passing through the square-shape openings to prevent scratching or damaging the unit.

#### ⚠ Caution:

##### Precautions When Transporting

- Units weighing 20 kg or more shall not be lifted by one person.
- Never touch the finned surface of the heat exchanger with your bare hands. This area can cause cuts or damage.
- Never allow children to play with the plastic bag used for covering the unit. Asphyxiation could occur. Always cut up the bag before disposing.
- Always use the designated spaces provided at the base of the unit when lifting the unit. Make sure that four support points are always used. The unit will be unstable and tip over or be dropped if lifted or transported using less than four support points.

### 4. Installing the outdoor unit

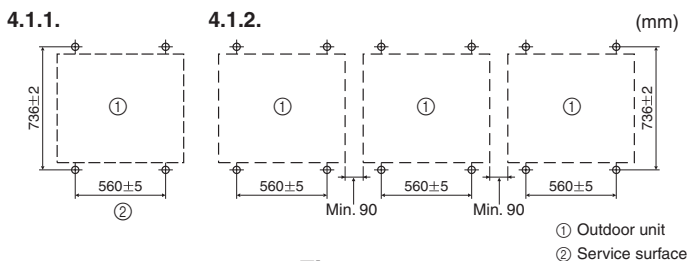

Fig. 4-1

#### 4.1. Positioning the anchor bolts

##### 4.1.1. When installing a single outdoor unit (Fig. 4-1)

##### 4.1.2. When installing multiple outdoor unit

- When installing in groups, always provide 90 mm of space between units.

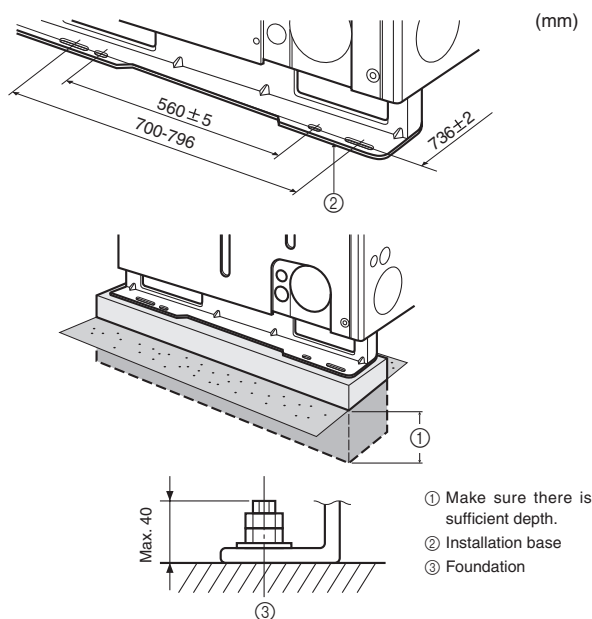

Fig. 4-2

#### 4.2. Requests when installing the units (Fig. 4-2)

- Do not block the air passageways for the unit. If the air passageways are blocked, trouble could occur in the operation of the unit.

#### ⚠ Warning:

- Always make certain that the surface onto which the unit is going to be installed has sufficient strength. If the surface is not strong enough, the unit could fall over and cause damage or injury.
- Make sure that the unit is installed so that it will be able to withstand earthquakes and strong winds. Damage or injury could occur if the unit tips over due to an earthquake or strong wind.
- Be sure to install the unit in a sturdy, level surface to prevent rattling noises during operation.

<Foundation specifications>

Foundation bolt	M10 (J type)
Thickness of concrete	120 mm
Length of bolt	70 mm
Weight-bearing capacity	320 kg

- Make sure that the length of the foundation bolt is within 40 mm of the bottom surface of the base.
- Secure the base of the unit firmly with four-M10 foundation bolts in sturdy locations. \* Procure the anchor bolts, nuts and washers locally.

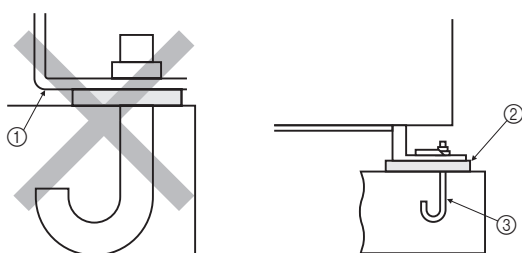

- ① Receiving the corner section.
- ② Make sure that the corner section is securely received. If the corner section is not securely received, the anchoring points could bend.
- ③ Procure the M10 anchor bolts locally.

Fig. 4-3

#### 4.3. Anchoring (Fig. 4-3)

- In order to enable the unit to withstand strong winds and earthquakes, make sure that the anchor bolts are installed as shown in the illustration.
  - Provide a strong foundation of concrete or angle iron.
  - With some types of installation, vibration will be conveyed along the base to floors and walls where it could create noise. In such locations, take measures to prevent vibration (such as using anti-vibration pads or suspension mounting for the unit).
- When performing the foundation work make sure that the floor surface has sufficient strength and carefully route piping and wiring in consideration of water drainage that will be required when the unit is operated.

## 5. Installing the refrigerant piping

### 5.1. Precautions for devices that use R410A refrigerant

- Refer to page 3 for precautions not included below on using air conditioners with R410A refrigerant.
- Use ester oil, ether oil, alkylbenzene oil (small amount) as the refrigeration oil applied to the flared sections.
- Use C1220 copper phosphorus, for copper and copper alloy seamless pipes, to connect the refrigerant pipes. Use refrigerant pipes with the thicknesses specified in the table to the below. Make sure the insides of the pipes are clean and do not contain any harmful contaminants such as sulfuric compounds, oxidants, debris, or dust.
- Always use a non-oxidizing brazing material when brazing the pipes. The compressor will be damaged if this type of brazing material is not used.

#### ⚠ Warning:

When installing or moving the air conditioner, use only the specified refrigerant (R410A) to charge the refrigerant lines. Do not mix it with any other refrigerant and do not allow air to remain in the lines. Air enclosed in the lines can cause pressure peaks resulting in a rupture and other hazards.

Pipe size (mm)	ø6.35	ø9.52	ø12.7	ø15.88	ø19.05	ø22.2	ø25.4	ø28.58
Thickness (mm)	0.8	0.8	0.8	1.0	1.0	1.0	1.0	1.0

- Do not use pipes thinner than those specified above.

### 5.2. Connecting pipes (Fig. 5-1)

- When commercially available copper pipes are used, wrap liquid and gas pipes with commercially available insulation materials (heat-resistant to 100 °C or more, thickness of 12 mm or more).
- The indoor parts of the drain pipe should be wrapped with polyethylene foam insulation materials (specific gravity of 0.03, thickness of 9 mm or more).
- Apply thin layer of refrigerant oil to pipe and joint seating surface before tightening flare nut. (A)
- Use two wrenches to tighten piping connections. (B)
- Use leak detector or soapy water to check for gas leaks after connections are completed.
- Apply refrigerating machine oil over the entire flare seat surface. (C)
- \* Do not apply to threaded portion. (It will cause the flare nut to loosen.)
- Use the flare nuts as follows. (D)

		RP2	RP2.5, 3	RP4-6
Gas side	Pipe size (mm)	ø12.7	ø15.88	ø15.88
	Indoor nut	*2	*1	*2
Liquid side	Pipe size (mm)	ø6.35	ø9.52	ø9.52
	Indoor nut	*2	*1	*1

\*1: The flare nut is attached to its pipe.

\*2: The flare nut is in the multi distribution pipe accessory.

Do not use the flare nut attached. If it is used, a gas leakage or even a pipe extraction may occur.

- When bending the pipes, be careful not to break them. Bend radii of 100 mm to 150 mm are sufficient.
- Make sure the pipes do not contact the compressor. Abnormal noise or vibration may result.

(1) Pipes must be connected starting from the indoor unit.

Flare nuts must be tightened with a torque wrench.

(2) Flare the liquid pipes and gas pipes and apply a thin layer of refrigeration oil (Applied on site).

- When usual pipe sealing is used, refer to Table 1 for flaring of R410A refrigerant pipes. The size adjustment gauge can be used to confirm A measurements.
- Always use a non-oxidizing brazing material when brazing the pipes. Only use good-quality brazing materials.

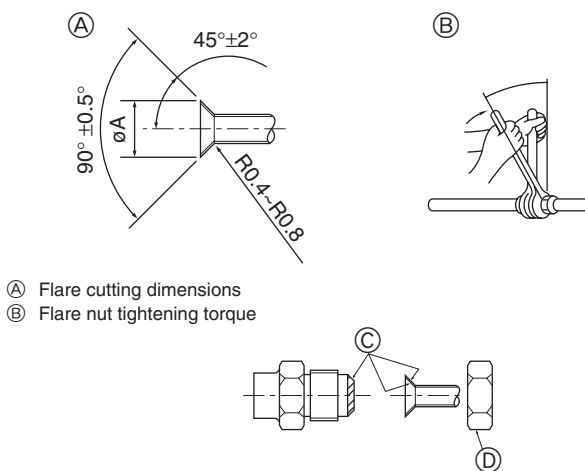

Fig. 5-1

(A) (Fig. 5-1)

Copper pipe O.D. (mm)	Flare dimensions øA dimensions (mm)
ø6.35	8.7 - 9.1
ø9.52	12.8 - 13.2
ø12.7	16.2 - 16.6
ø15.88	19.3 - 19.7
ø19.05	23.6 - 24.0

(B) (Fig. 5-1)

Copper pipe O.D. (mm)	Flare nut O.D. (mm)	Tightening torque (N·m)
ø6.35	17	14 - 18
ø6.35	22	34 - 42
ø9.52	22	34 - 42
ø12.7	26	49 - 61
ø12.7	29	68 - 82
ø15.88	29	68 - 82
ø15.88	36	100 - 120
ø19.05	36	100 - 120

## 5. Installing the refrigerant piping

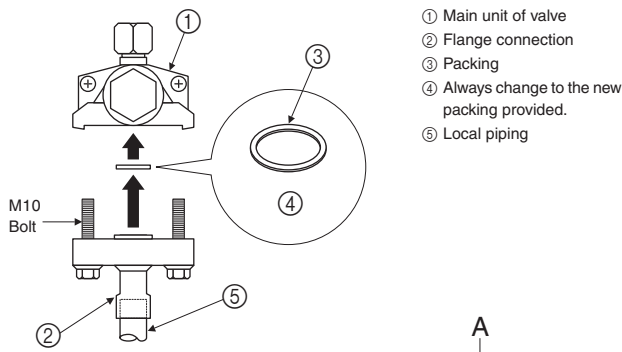

Fig. 5-2

- ① Main unit of valve
- ② Flange connection
- ③ Packing
- ④ Always change to the new packing provided.
- ⑤ Local piping

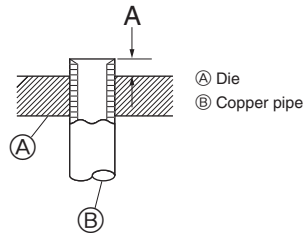

Fig. 5-3

- (3) Use the following procedure for connecting the gas-side piping. (Fig. 5-2)
  1. Remove the flange and packing attached to the valve body. These were mounted at the time of shipping from the factory to prevent refrigerant leakage.
    - \* Never attempt to reuse this packing as refrigerant leakage will occur.
  2. Braze the flange joint ② provided to the outdoor unit using locally procured brazing materials.
    - \* Always perform this brazing before mounting the stop valve.
  3. Always attach the new packing ③, provided, for the connecting pipe with the flange to the valve body before connecting the piping to the stop valve.
    - \* The tightening torque for M10 bolts for the flange joint : 25.2 N·m ±15%.
- (4) After connecting the installing bolts for the refrigerant piping, check for gas leakage in the locally installed piping and indoor units.

Table 3 (Fig. 5-3)

Copper pipe O.D. (mm)	A (mm)	
	Flare tool for R410A	Flare tool for R22-R407C
	Clutch type	
ø6.35 (1/4")	0 - 0.5	1.0 - 1.5
ø9.52 (3/8")	0 - 0.5	1.0 - 1.5
ø12.7 (1/2")	0 - 0.5	1.0 - 1.5
ø15.88 (5/8")	0 - 0.5	1.0 - 1.5

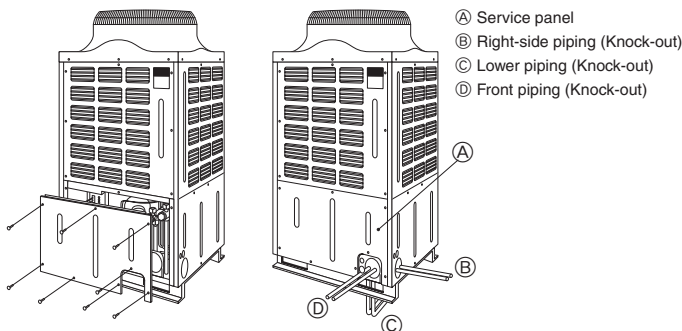

Fig. 5-4

- Ⓐ Service panel
- Ⓑ Right-side piping (Knock-out)
- Ⓒ Lower piping (Knock-out)
- Ⓓ Front piping (Knock-out)

### 5.3. Refrigerant piping (Fig. 5-4)

Remove the service panel (A) (eight screw).

- (1) Perform refrigerant piping connections for the indoor/outdoor unit when the outdoor unit's stop valve is completely closed.
- (2) Vacuum-purge air from the indoor unit and the connection piping.
- (3) After connecting the refrigerant pipes, check the connected pipes and the indoor unit for gas leaks. (Refer to 5.4 Refrigerant pipe airtight testing method)
- (4) Vacuumize the refrigerant lines through the service port of the liquid stop valve and then open the stop valves completely (for both the liquid and gas stop valves). This will completely connect the refrigerant lines of the indoor and outdoor units.
  - If the stop valves are left closed and the unit is operated, the compressor and control valves will be damaged.
  - Use a leak detector or soapy water to check for gas leaks at the pipe connection sections of the outdoor unit.
  - Do not use the refrigerant from the unit to purge air from the refrigerant lines.
  - After the valve work is completed, tighten the valve caps to the correct torque.

Valve size	Tightening torque N·m (kgf·cm)	
	Valve cap	Service port cap
3/8 ø9.52	22-28 (220-280)	12-16
1/2 ø12.7	25-31 (250-310)	(120-160)
1 ø25.4	36-44 (360-440)	11.5-13.9 (115-139)

Failure to replace and tighten the caps may result in refrigerant leakage. In addition, do not damage the insides of the valve caps as they act as a seal to prevent refrigerant leakage.

- (5) Use sealant to seal the ends of the thermal insulation around the pipe connection sections to prevent water from entering the thermal insulation.

### 5.4. Refrigerant pipe airtight testing method (Fig. 5-5)

- (1) Connect the testing tools.
  - Make sure the stop valves (A) (B) are closed and do not open them.
  - Add pressure to the refrigerant lines through the service port (C) of the liquid stop valve (D).
- (2) Do not add pressure to the specified pressure all at once; add pressure little by little.
  - ① Pressurize to 0.5 MPa (5 kgf/cm<sup>2</sup>G), wait five minutes, and make sure the pressure does not decrease.
  - ② Pressurize to 1.5 MPa (15 kgf/cm<sup>2</sup>G), wait five minutes, and make sure the pressure does not decrease.
  - ③ Pressurize to 3.6 MPa (36 kgf/cm<sup>2</sup>G) and measure the surrounding temperature and refrigerant pressure.
- (3) If the specified pressure holds for about one day and does not decrease, the pipes have passed the test and there are no leaks.
  - If the surrounding temperature changes by 1 °C, the pressure will change by about 0.03 MPa (0.3 kgf/cm<sup>2</sup>G). Make the necessary corrections.
- (4) If the pressure decreases in steps (2) or (3), there is a gas leak. Look for the source of the gas leak.

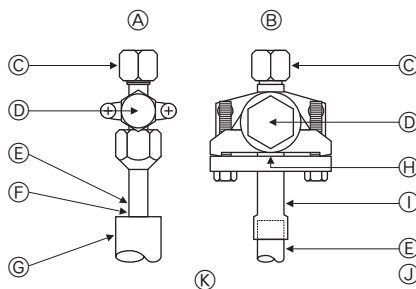

- Ⓐ Stop valve <Liquid side>
- Ⓑ Stop valve <Gas side>
- Ⓒ Service port
- Ⓓ Open/Close section
- Ⓔ Local pipe
- Ⓕ Sealed, same way for gas side
- Ⓖ Pipe cover
- Ⓗ Packing (Provided part)
- Ⓘ Connecting pipe (Provided part)
- Ⓝ Use non-oxidizing brazing material on flange joint.
- Ⓚ Locally procured pipe connection

Fig. 5-5



## 5. Installing the refrigerant piping

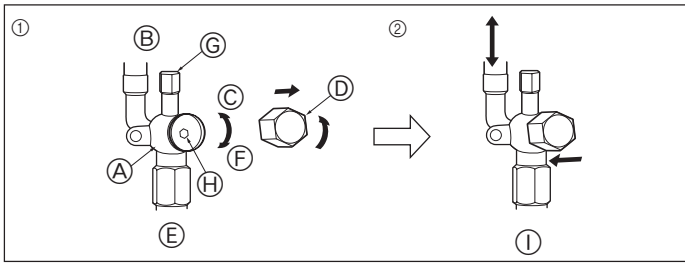

Fig. 5-6

### 5.5. Stop valve opening method (Fig. 5-6)

- (1) Remove the cap and turn the valve rod counterclockwise as far as it will go with the use of hexagonal wrench. Stop turning when it hits the stopper.
- (2) Make sure that the stop valve is open completely, push in the handle and rotate the cap back to its original position.

- Ⓐ Valve
- Ⓑ Unit side
- Ⓒ Open
- Ⓓ Cap
- Ⓔ Local pipe side
- Ⓕ Close
- Ⓖ Service port
- Ⓗ Wrench hole
- Liquid side : 4 mm hexagonal wrench
- Gus side : 10 mm hexagonal wrench

### 5.6. Addition of refrigerant (Fig. 5-7)

- Additional charging is not necessary for this unit if the pipe length does not exceed 30 m.
- If the pipe length exceeds 30 m, charge the unit with additional R410A refrigerant according to the permitted pipe lengths in the chart below.
  - \* When the unit is stopped, charge the unit with the additional refrigerant through the liquid stop valve after the pipe extensions and indoor unit have been vacuumized.
  - When the unit is operating, add refrigerant to the gas check valve using a safety charger. Do not add liquid refrigerant directly to the check valve.

- \* After charging the unit with refrigerant, note the added refrigerant amount on the service label (attached to the unit). Refer to the "1.5. Using R410A refrigerant air conditioners" for more information.
- Be careful when installing multiple units. Connecting to an incorrect indoor unit can lead to abnormally high pressure and have a serious effect on operation performance.

Outdoor unit	At time of shipping (kg)	A+B+C+D					
		Amount of additional refrigerant charge (kg)					
		30 m and less	31-40 m and less	41-50 m and less	51-60 m and less	61-70 m and less	71-80 m and less
RP8	10.5	No additional charge necessary	0.9 kg	1.8 kg	2.7 kg	3.6 kg	Calculate the amount of additional refrigerant charge using formula provided below.
RP10	10.5		1.2 kg	2.4 kg	3.6 kg	4.8 kg	

#### When length exceeds 70 m

When the total length of the piping exceeds 70 m, calculate the amount of additional charge based on the following requirements.

Note: If the calculation produces a negative number (i.e. a "minus" charge), if calculation results in an amount that is less than the "Additional charge amount for 70 m," perform the additional charge using the amount shown in "Additional charge amount for 70 m."

Amount of additional charge (kg)	=	Main piping: Liquid line size $\phi 12.7$ overall length $\times 0.12$ (m) $\times 0.12$ (kg/m)	+	Main piping: Liquid line size $\phi 9.52$ overall length $\times 0.09$ (Gas line: $\phi 28.58$ ) (m) $\times 0.09$ (kg/m)	+	Branch piping: Liquid line size $\phi 9.52$ overall length $\times 0.06$ (Gas line: $\phi 15.88$ ) (m) $\times 0.06$ (kg/m)	+	Branch piping: Liquid line size $\phi 6.35$ overall length $\times 0.02$ (Gas line: $\phi 15.88$ ) (m) $\times 0.02$ (kg/m)	-	3.6 (kg)
----------------------------------	---	--	---	--	---	--	---	--	---	----------

Additional charge amount for 70 meters	RP8	3.6 kg
	RP10	4.8 kg

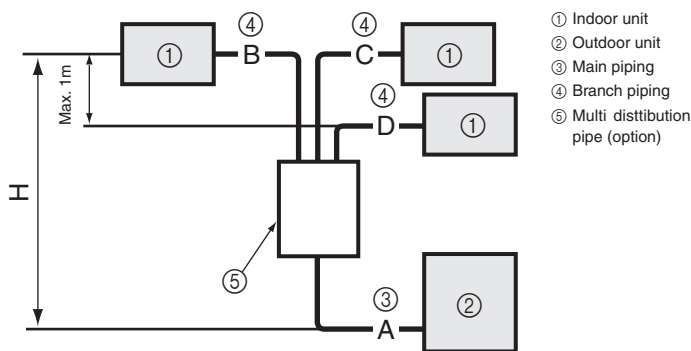

Fig. 5-7

Outdoor unit : RP10 A:  $\phi 12.7$  ... 65 m  
 Indoor unit 1 : RP3 B:  $\phi 9.52$  ... 5 m  
 Indoor unit 2 : RP3 C:  $\phi 9.52$  ... 5 m  
 Indoor unit 3 : RP3 D:  $\phi 9.52$  ... 5 m

Main piping  $\phi 12.7$  is A = 65 m  
 Branch piping  $\phi 9.52$  is B + C + D = 15 m  
 Therefore, the amount of additional charge is:  $65 \times 0.12 + 15 \times 0.06 - 3.6 = 5.1$  (kg)  
 (Fractions are rounded up)

## 5. Installing the refrigerant piping

### 5.7. Precautions when reusing existing R22 refrigerant pipes

- Refer to the flowchart below to determine if the existing pipes can be used.
- See below for oil condition.  
Clear to slight yellow color → Normal  
Black or brown → Pipe cleaning is necessary.
- If the diameter of the existing pipes is different from the specified diameter, refer to technological data materials to confirm if the pipes can be used.
- Additional charge amount for 70 m.

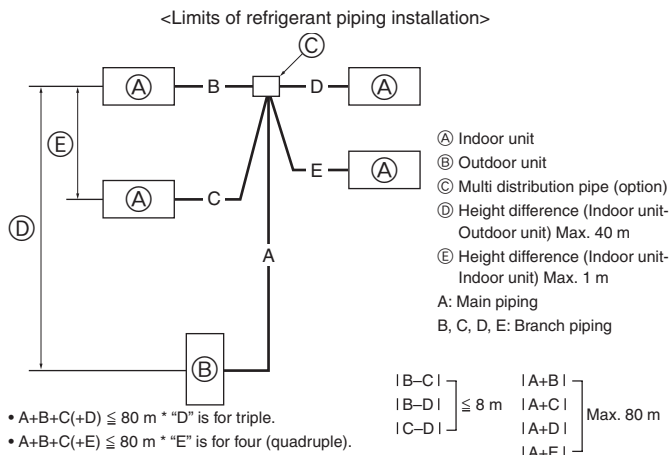
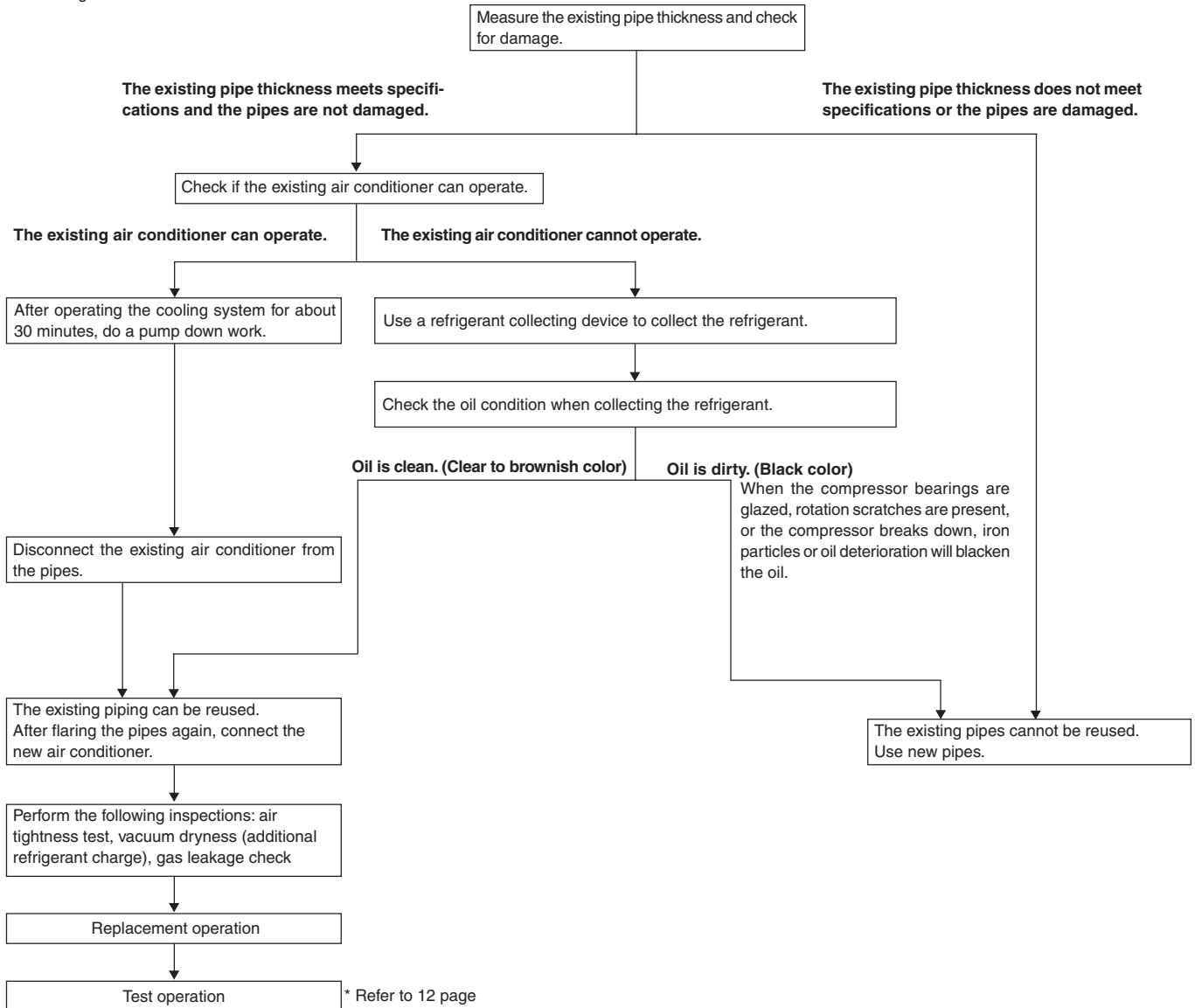

Fig. 5-8

### 5.8. For twin/triple/quadruple combination (Fig. 5-8)

- When this unit is used as a FREE COMPO MULTI unit, install the refrigerant piping with the restrictions indicated in the drawing on the left. In addition, if the restrictions are going to be exceeded, or if there are going to be combinations of indoor and outdoor units, refer to installation instructions for the indoor unit for details about the installation.

Outdoor unit	Permissible total piping length A+B+C+D+E	A+B or A+C or A+D or A+E	Charge-less piping length A+B+C+D+E
RP8 PR10	80 m and less	80 m and less	30 m and less
Outdoor unit	B-C  or  B-D  or  B-E  or  C-D  or  C-E  or  D-E		No. of bends
RP8 RP10	8 m and less		Within 15

## 6. Drainage piping work

It is possible to have the drain flow out along the bottom of the outdoor unit. Use the centralized drainage kit when using drain piping.

## 7. Electrical work

### 7.1. Outdoor unit (Fig. 7-1, Fig. 7-2)

- (1) Remove the service panel.
- (2) Wire the cables referring to the Fig. 7-1 and the Fig. 7-2.

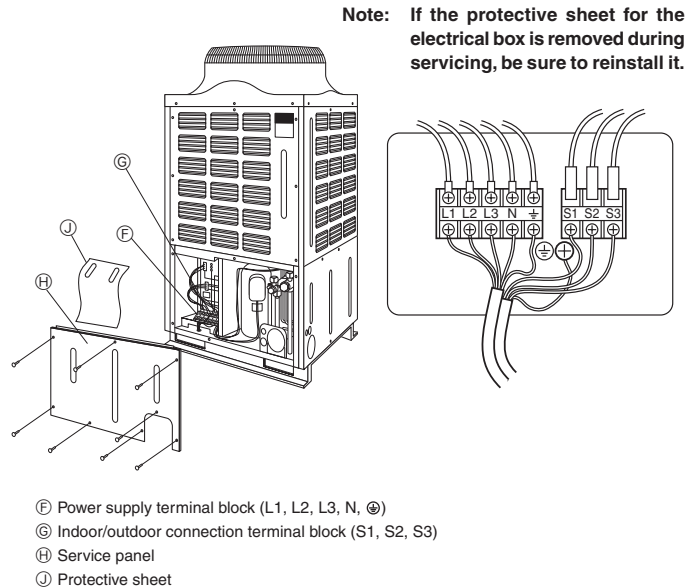
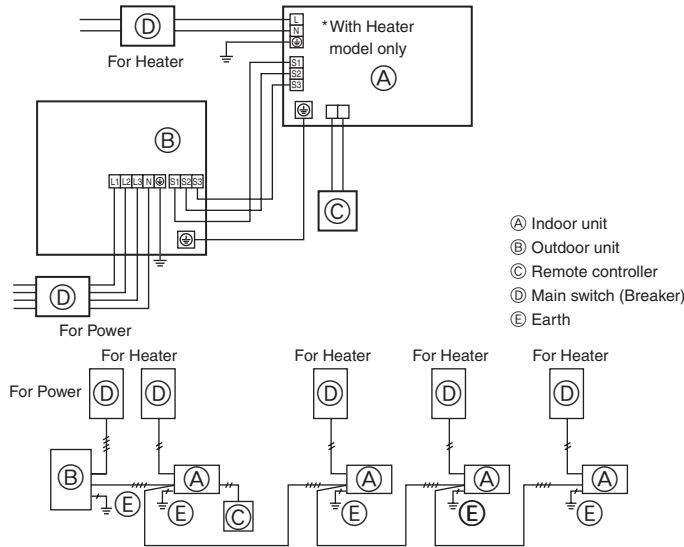

**Note:** If the protective sheet for the electrical box is removed during servicing, be sure to reinstall it.

### 7.2. Field electrical wiring

Indoor unit model		RP8, 10
Outdoor unit Power supply	Phase	3N-(3ph 4-wires), 50Hz,
	Frequency & Voltage	380-400-415V
	Max. Permissive System Impedance (Ω)	0.25
Outdoor unit input capacity	*1	32A
Main switch (Breaker)		
Wiring Wire No. x size (mm <sup>2</sup> )	Outdoor unit power supply	4 x Min. 6
	Outdoor unit power supply earth	1 x Min. 6
	Indoor unit-Outdoor unit	*2 Cable length 50 m : 3 x 4 (Polar)/Cable length 80 m : 3 x 6 (Polar)
	Indoor unit-Outdoor unit earth	1 x Min. 2.5
Circuit rating	Remote controller-Indoor unit	*3 2 x 0.69 (Non-polar)
	Outdoor unit L1-N, L2-N, L3-N	AC 220-230-240V
	Indoor unit-Outdoor unit S1-S2	*4 AC 220-230-240V
	Indoor unit-Outdoor unit S2-S3	DC24V
	Remote controller-Indoor unit	*4 DC14V

\*1. A breaker with at least 3 mm contact separation in each pole shall be provided. Use non-fuse breaker (NF) or earth leakage breaker (NV).

\*2. Max. 80 m Total Max. including all indoor/ indoor connection is 80 m.

\*3. Use one cable for S1 and S2 and another for S3 as shown in the picture.

\*4. A 10 m wire is attached in the remote controller accessory.

\*5. The voltage are NOT against the ground.

S3 terminal has DC 24 V against S2 terminal. However between S3 and S1, these terminals are not electrically insulated by the transformer or other device.



**Notes:** 1. Wiring size must comply with the applicable local and national code.

2. Power supply cords and indoor unit/Outdoor unit connecting cords shall not be lighter than polychloroprene sheathed flexible cord. (Design 245 IEC 57)



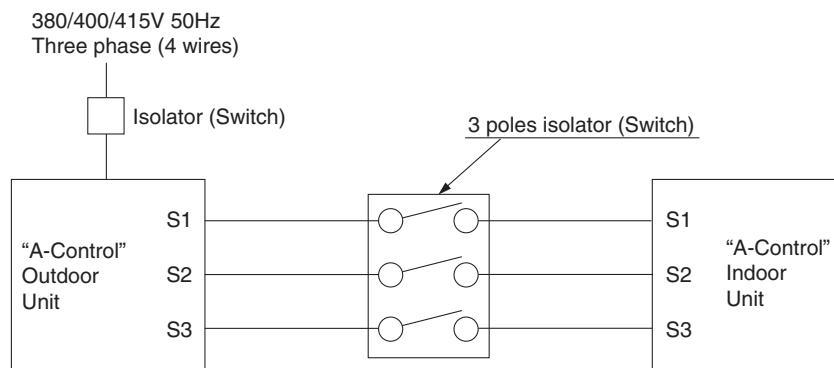

3. Use an earth wire which is longer than the other cords so that it will not become disconnected when tension is applied. The earth wire should also be thicker than the power supply cord so that it can stand any surge of electricity when trouble occurs.



#### Warning:

In case of A-control wiring, there is high voltage potential on the S3 terminal caused by electrical circuit design that has no electrical insulation between power line and communication signal line. Therefore, please turn off the main power supply when servicing. And do not touch the S1, S2, S3 terminals when the power is energized. If isolator should be used between indoor unit and outdoor unit, please use 3-poles type.

**WIRING SPECIFICATIONS FOR 220-240 V 50 Hz  
(INDOOR-OUTDOOR CONNECTING CABLE)**

Cross section of cable	Wire size (mm <sup>2</sup> )	Number of wires	Polarity	L (m)*6
Round 	2.5	3	Clockwise : S1-S2-S3 * Pay attention to stripe of yellow and green	(30) *2
Flat 	2.5	3	Not applicable (Because center wire has no cover finish)	Not applicable *5
Flat 	1.5	4	From left to right : S1-Open-S2-S3	(18) *3
Round 	2.5	4	Clockwise : S1-S2-S3-Open *Connect S1 and S3 to the opposite angle	(30) *4

\*1 : Power supply cords of appliances shall not be lighter than design 245 IEC or 227 IEC.

\*2 : In case that cable with stripe of yellow and green is available.

\*3 : In case of regular polarity connection (S1-S2-S3), wire size is 1.5 mm<sup>2</sup>.

\*4 : In case of regular polarity connection (S1-S2-S3).

\*5 : In the flat cables are connected as this picture, they can be used up to 30 m.

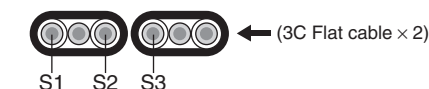

\*6 : Mentioned cable length is just a reference value.

It may be different depending on the condition of installation, Humidity or materials, etc.

Be sure to connect the indoor-outdoor connecting cables directly to the units (no intermediate connections). Intermediate connections can lead to communication errors if water enters the cables and causes insufficient insulation to ground or a poor electrical contact at the intermediate connection point.  
(If an intermediate connection is necessary, be sure to take measures to prevent water from entering the cables.)

## 8. Test run

### 8.1. Before test run

- ▶ After completing installation and the wiring and piping of the indoor and outdoor units, check for refrigerant leakage, looseness in the power supply or control wiring, wrong polarity, and no disconnection of one phase in the supply.
- ▶ Use a 500-volt megohmmeter to check that the resistance between the power supply terminals and ground is at least 1 MΩ.
- ▶ Do not carry out this test on the control wiring (low voltage circuit) terminals.

#### Insulation resistance

After installation or after the power source to the unit has been cut for an extended period, the insulation resistance will drop below several MΩ due to refrigerant accumulating in the compressor.

In this case, turn on the power and check that the insulation resistance has recovered while the unit is operating. By operating the unit, the refrigerant that has accumulated in the compressor will flow through the refrigerant piping.

#### Leakage breaker

Always use a current leakage breaker that is compatible with higher harmonics as this unit is equipped with an inverter.

#### ⚠ Caution:

- The compressor will not operate unless the power supply phase connection is correct.

#### ▶ The followings must be checked as well.

- The outdoor unit is not faulty. LED1 and LED2 on the control board of the outdoor unit flash when the outdoor unit is faulty.
- Both the gas and liquid stop valves are completely open.
- A protective sheet covers the surface of the DIP switch panel on the control board of the outdoor unit. Remove the protective sheet to operate the DIP switches easily.
- Make sure that all of the SW5 DIP switches for function changes on the control board of the outdoor unit are set to OFF. If all of the SW5 switches are not set to OFF, record the settings and then set all of the switches to OFF. Begin recovering the refrigerant. After moving the unit to a new location and completing the test run, set the SW5 switches to the previously recorded settings.

### 8.2. Unit replacement operation

- ▶ Replacement operation is the operation by which impurities remaining in the existing piping (chlorinated compounds) are captured by the activated carbon filter (replacement filter) in the outdoor unit.

• This model will automatically begin the replacement operation after it has been installed when it enters the initialization phase for normal heating or cooling. However, the unit will not automatically perform the replacement operation if it is moved to a new location where it will be used with existing R22 refrigerant piping. Under such conditions, always use the SW8-2 operations to perform the replacement operation before beginning the test operation.

#### Replacement operation procedures (When moving the unit and connecting it to existing R22 piping.)

- ① Supply power.
- ② Set DIP switch SW8-2 on the control board of the outdoor unit to ON to start replacement operation.
  - \* The replacement operation is performed using the cooling system. Cool air will flow from the indoor unit during the replacement operation.
  - \* During the replacement operation,  is displayed on the remote controller and LED1 and LED2 on the control board of the outdoor unit flash together.
- ③ The duration of the replacement operation is determined by the length of the piping. Always perform the replacement operation for longer than the stipulated time.
  - \* Always perform one of the following operations at the completion of the replacement operation. The replacement operation will end and the unit will automatically stop.

(1) Set SW8-2 from ON to OFF. (When ending a replacement operation of less than 2 hours.)

- Each time SW8-2 is set from OFF to ON, the replacement operation can be started. Always perform the replacement operation for longer than the stipulated time.

Required replacement operation times

Piping Length	Replacement Operation Time
0 to 20 meters	30 minutes or more
21 to 30 meters	45 minutes or more
31 to 70 meters	60 minutes or more

(2) The replacement operation will automatically stop after 2 hours. (It will end with SW8-2 still in the ON position.)

- When the replacement operation has ended automatically after 2 hours of operation, there is no need to set SW8-2 from ON to OFF; normal air conditioning operations can be possible with the SW8-2 set to ON. Furthermore, to repeat the replacement operation, SW8-2 will have to be returned to OFF and then set to ON.

\* If the indoor temperature is less than 15 °C, the compressor will operate intermittently but the unit is not faulty.

### 8.3. Test run

#### 8.3.1. Using SW4 in outdoor unit

SW4-1	ON	Cooling operation
SW4-2	OFF	
SW4-1	ON	Heating operation
SW4-2	ON	

\* After performing the test run, set SW4-1 to OFF.

- After power is supplied, a small clicking noise may be heard from the inside of the outdoor unit. The electronic expansion valve is opening and closing. The unit is not faulty.

- A few seconds after the compressor starts, a clanging noise may be heard from the inside of the outdoor unit. The noise is coming from the check valve due to the small difference in pressure in the pipes. The unit is not faulty.

**The test run operation mode cannot be changed by DIP switch SW4-2 during the test run. (To change the test run operation mode during the test run, stop the test run by DIP switch SW4-1. After changing the test run operation mode, resume the test run by switch SW4-1.)**

#### 8.3.2. Using remote controller

Refer to the indoor unit installation manual.

## 9. Special Functions

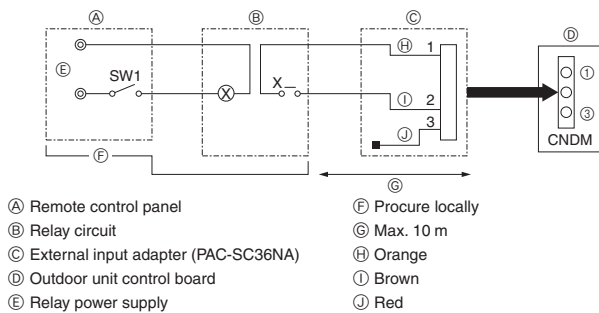

Fig. 9-1

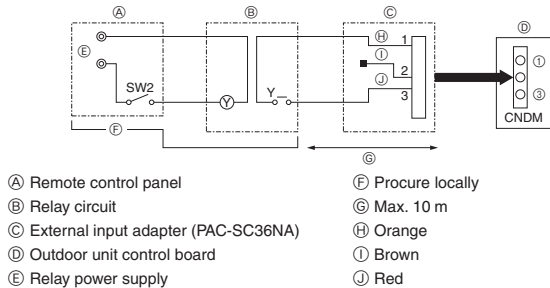

Fig. 9-2

### 9.1. Low noise mode (on-site modification) (Fig. 9-1)

By performing the following modification, operation noise of the outdoor unit can be reduced by about 3-4 dB.

The low noise mode will be activated when a commercially available timer or the contact input of an ON/OFF switch is added to the CNDM connector (option) on the control board of the outdoor unit.

- The ability varies according to the outdoor temperature and conditions, etc.
- ① Complete the circuit as shown when using the external input adapter (PAC-SC36NA). (Option)
- ② DIP switch SW7-1 ON: Low noise mode  
DIP switch SW7-1 OFF: Normal operation

### 9.2. Demand function (on-site modification) (Fig. 9-2)

• It is possible to reduce electricity consumption within a range from 0 to 100 percent by performing the following on-site installation.

The demand function can be enabled by adding a commercially available input contact point ON/OFF switch to the CNDM connector (the contact point demand input, sold separately).

- ① Incorporate the "Adaptor for external input (PAC-SC36NA)" into the circuit as shown in the diagram on the left.
- ② By switching SW7-1 and SW7-2 on the control circuit board for the outdoor unit, the following power consumption restrictions (compared to rated power) can be set.

SW7-1	SW7-2	Power consumption when SW2 is on
OFF	OFF	0% (STOP)
ON	OFF	50%
OFF	ON	75%

### 9.3. Refrigerant collecting (pump down)

Perform the following procedures to collect the refrigerant when moving the indoor unit or the outdoor unit.

- ① Before collecting the refrigerant, first make sure that all of the SW5 DIP switches for function changes on the control board of the outdoor unit are set to OFF. If all of the SW5 switches are not set to OFF, record the settings and then set all of the switches to OFF. Start collecting the refrigerant. After moving the unit to a new location and completing the test run, set the SW5 switches to the previously recorded settings.
- ② Supply power (circuit breaker).
  - \* When power is supplied, make sure that "CENTRALLY CONTROLLED" is not displayed on the remote controller. If "CENTRALLY CONTROLLED" is displayed, the refrigerant collecting (pump down) cannot be completed normally.
- ③ After the liquid stop valve is closed, set the SWP switch on the control board of the outdoor unit to ON. The compressor (outdoor unit) and ventilators (indoor and outdoor units) start operating and refrigerant collecting operation begins. LED1 and LED2 on the control board of the outdoor unit are lit.

- \* Only set the SWP switch (push-button type) to ON if the unit is stopped. However, even if the unit is stopped and the SWP switch is set to ON less than three minutes after the compressor stops, the refrigerant collecting operation cannot be performed. Wait until the compressor has been stopped for three minutes and then set the SWP switch to ON again.
- ④ Because the unit automatically stops in about two to three minutes after the refrigerant collecting operation (LED1 and LED2 are lit), be sure to quickly close the gas stop valve. When LED1 and LED2 are lit and the outdoor unit is stopped, open the liquid stop valve completely, and then repeat step ③ after three minutes have passed.
  - \* If the refrigerant collecting operation has been completed normally (LED1 and LED2 are lit), the unit will remain stopped until the power supply is turned off.
- ⑤ Turn off the power supply (circuit breaker).
  - \* Note that when the length of the extension piping is long, it may not be possible to perform a pump-down operation. When performing the pump-down operation, make sure that the low pressure is lowered to near 0 MPa (gauge).

## 10. System control (Fig. 10-1)

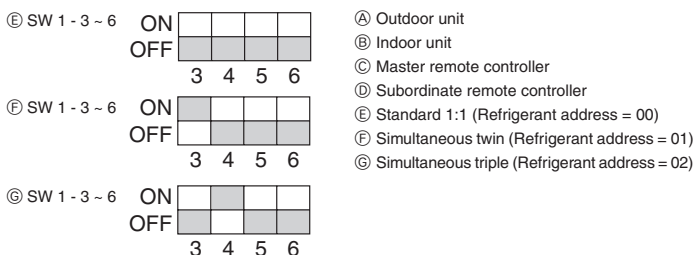

Fig. 10-1

\* Set the refrigerant address using the DIP switch of the outdoor unit.

- ① Wiring from the Remote Control  
This wire is connected to TB5 (terminal board for remote controller) of the indoor unit (non-polar).
- ② When a Different Refrigerant System Grouping is Used.  
Up to 16 refrigerant systems can be controlled as one group using the slim MA remote controller.

**Note:**

In single refrigerant system (twin/triple/quadruple), there is no need of wiring ②.

SW1  
Function table

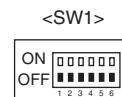

Function	Operation according to switch setting	
	ON	OFF
1 Compulsory defrosting	Start	Normal
2 Error history clear	Clear	Normal
3 Refrigerant system address setting	Settings for outdoor unit addresses 0 to 15	
4		
5		
6		

## 11. Information on rating plate

Model		RP8, 10
Refrigerant (R410A)	kg	10.5
Allowable pressure (Ps)		HP:3.6 MPa (36 bar), LP:2.3 MPa (23 bar)
Net weight	kg	198
MANUFACTURER: MITSUBISHI ELECTRIC CORPORATION, SHIZUOKA WORKS 18-1, OSHIKA 3-CHOME, SHIZUOKA CITY, JAPAN		

This product is designed and intended for use in the residential,  
commercial and light-industrial environment.

- The product at hand is based on the following EU regulations:
- Low Voltage Directive 73/23/ EEC
  - Electromagnetic Compatibility Directive 89/336/ EEC
  - Pressure Equipment Directive 97/23/ EC

Please be sure to put the contact address/telephone number on  
this manual before handing it to the customer.