

mitsubishi electric

Air-Conditioners ROOFTOP UNIT

CE

PRH-P8, 10MYA

**FOR INSTALLER
FÜR INSTALLATEUR
POUR L'INSTALLATEUR
PARA EL INSTALADOR**

**PER L'INSTALLATORE
VOOR DE INSTALLATEUR
FÖR INSTALLATÖREN
PARA O INSTALADOR**

GB

D

F

E

INSTALLATION MANUAL

For safe and correct use, please read this operation manual thoroughly before operating the air-conditioner unit.

INSTALLATIONSHANDBUCH

Zum sicheren und ordnungsgemäßen Gebrauch der Klimageräte das Installationshandbuch gründlich durchlesen.

MANUEL D'INSTALLATION

Veillez lire le manuel d'installation en entier avant d'installer ce climatiseur pour éviter tout accident et vous assurer d'une utilisation correcte.

MANUAL DE INSTALACIÓN

Para un uso seguro y correcto, lea detalladamente este manual de instalación antes de montar la unidad de aire acondicionado.

MANUALE DI INSTALLAZIONE

Per un uso sicuro e corretto, leggere attentamente questo manuale di installazione prima di installare il condizionatore d'aria.

INSTALLATIEHANDLEIDING

Voor een veilig en juist gebruik moet u deze installatiehandleiding grondig doorlezen voordat u de airconditioner installeert.

INSTALLATIONSMANUAL

Läs denna installationsmanual noga för säkert och korrekt bruk innan luftkonditioneringen installeras.

MANUAL DE INSTALAÇÃO

Para segurança e utilização correctas, leia atentamente este manual de instalação antes de instalar a unidade de ar condicionado.

I

NL

SW

P

3

[Fig. 3.1.1]

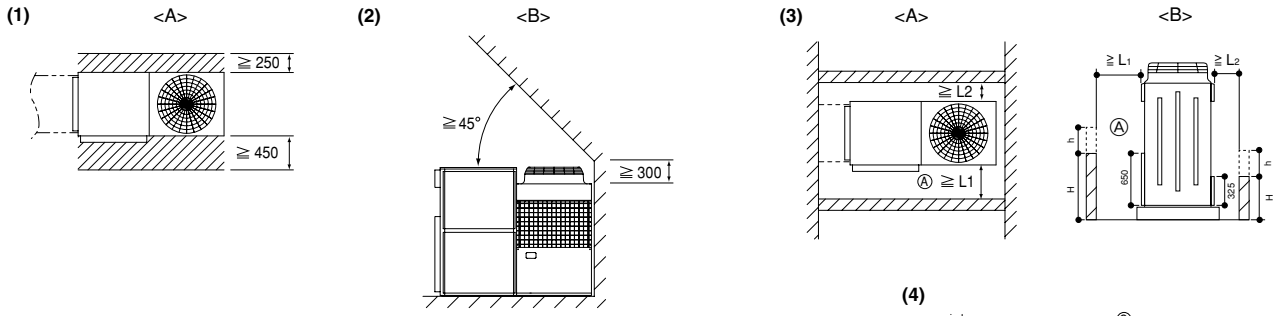

4

[Fig. 4.0.1]

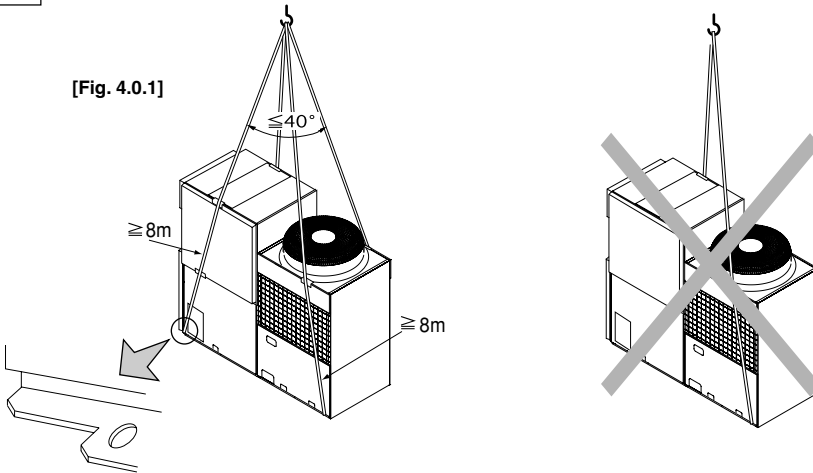

(4)

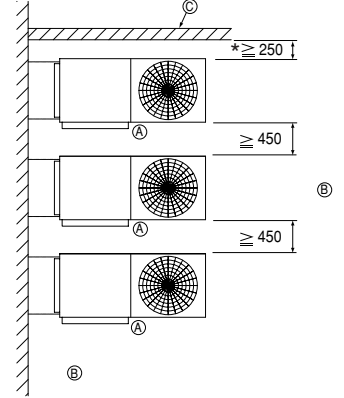

<A> Top view
 Side view
 (A) Front
 (B) Must be open
 (C) Wall height (H)
 L1: 450 L2: 250

5

[Fig. 5.1.1]

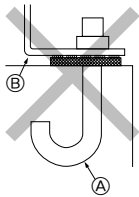

(A) M10 anchor bolt procured at the site.
 (B) Corner is not seated.

[Fig. 5.1.2]

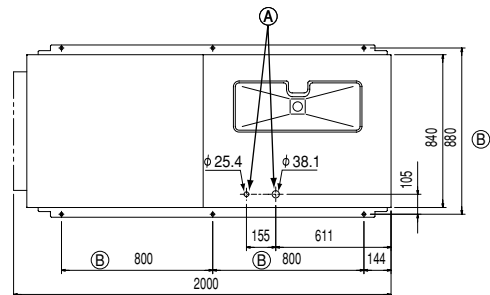

(A) Bottom wiring through hole
 (B) (bolt hole)

6

[Fig.6.0.1]

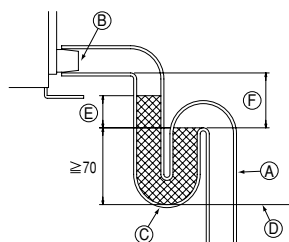
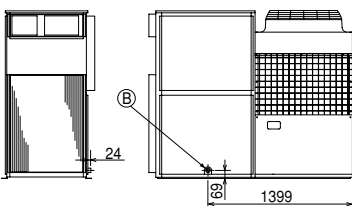

(A) Drain piping
 (B) Socket R1
 (C) Drain trap
 (D) The drain pipe should extend below the level.
 (E) $\geq 2 \times$ External static pressure
 (F) $\geq 2 \times$ (E)

[Fig.7.0.1]

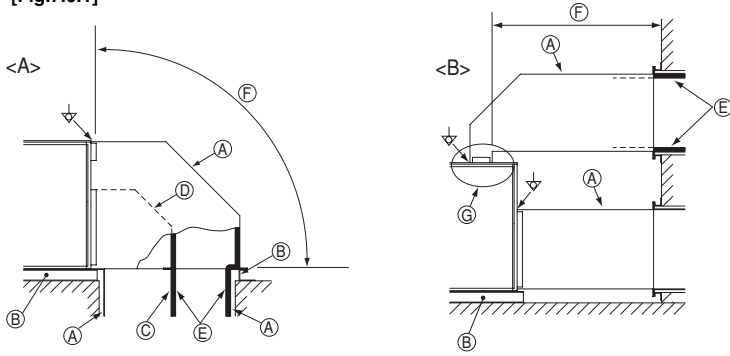

- <A> Ex. Side flow
- Ex. Top flow
- Ⓐ Duct
- Ⓑ Roof curb
- Ⓒ Single duct divider
- Ⓓ Plenum divider
- Ⓔ Insulator
- Ⓕ Keep duct-work length 850 mm or more
- Ⓖ Rainproof the part where the duct flange is screwed on (Top flow only).

[Fig.7.0.2]

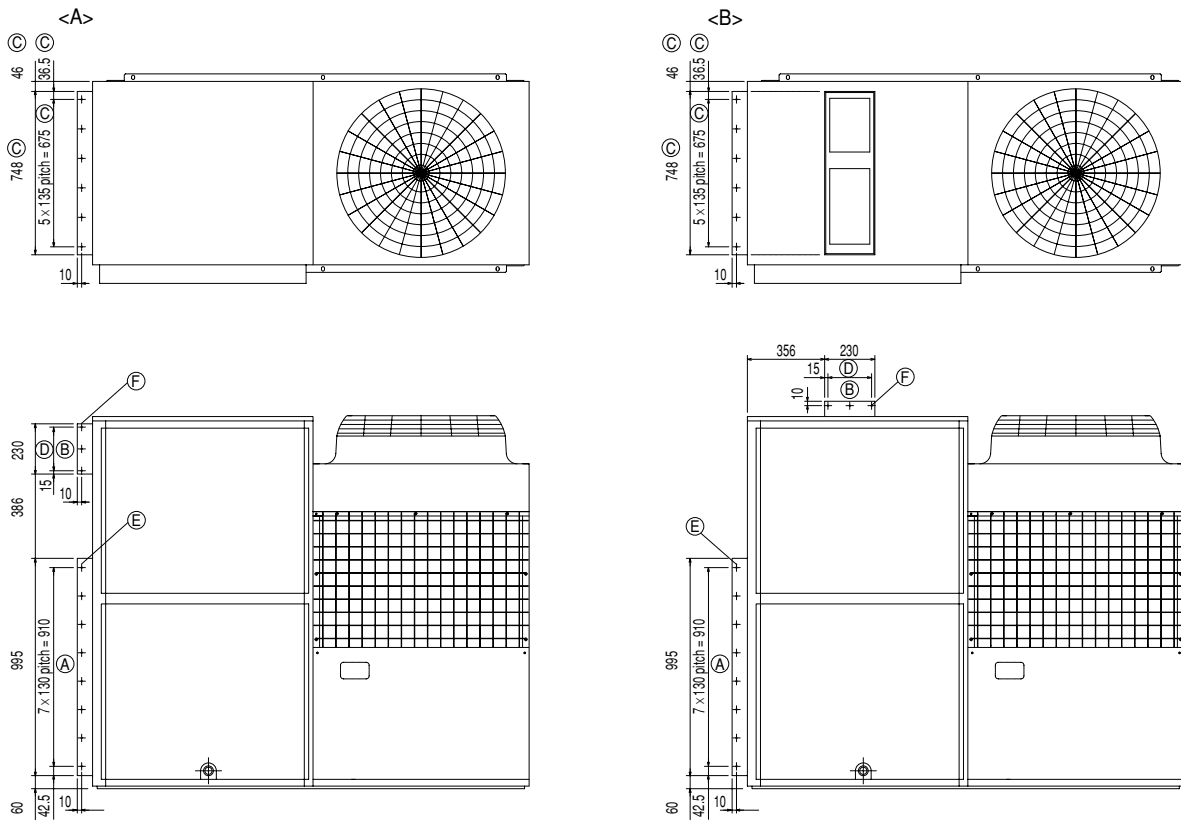

- <A> In case of side flow
- In case of top flow
- Ⓐ Inlet duct flange
- Ⓑ Outlet duct flange
- Ⓒ Same as inlet and outlet duct flange
- Ⓓ 2 × 100 pitch = 200
- Ⓔ 28 - ø3 holes (Inlet duct mount holes)
- Ⓕ 18 - ø3 holes (Outlet duct mount holes)

7.1

[Fig.7.1.1]

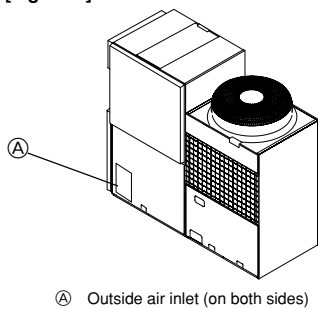

- Ⓐ Outside air inlet (on both sides)

[Fig.7.1.2]

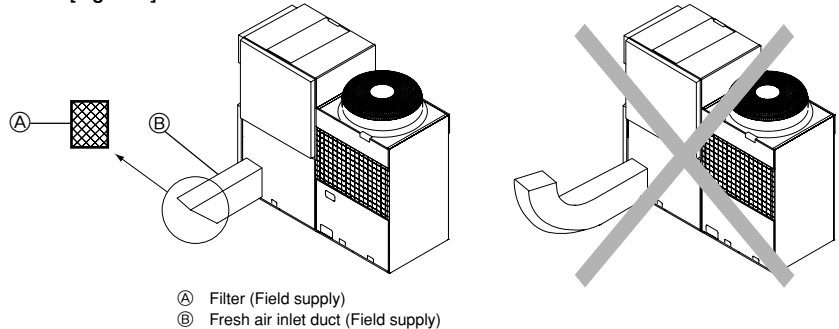

- Ⓐ Filter (Field supply)
- Ⓑ Fresh air inlet duct (Field supply)

[Fig.8.1.1]

(1)

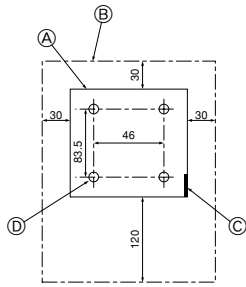

- (A) Remote controller profile
- (B) Required clearances surrounding the remote controller
- (C) Temperature sensor
- (D) Installation pitch

(2)

<A> For installation in the switch box:

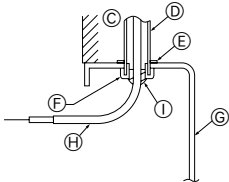

- (C) Wall
- (D) Conduit
- (E) Lock nut
- (F) Bushing
- (G) Switch box
- (H) Remote controller cord
- (I) Seal with putty.

 For direct installation on the wall select one of the following:

B-1.

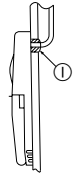

B-2.

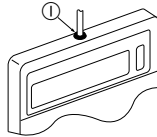

(3)

<A> For installation in the switch box

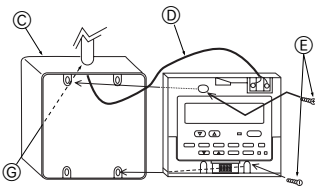

- (C) Switch box for two pieces
- (D) Remote controller cord
- (E) Cross-recessed, pan-head screw
- (G) Seal the remote controller cord service entrance with putty
- (H) Wood screw

 For direct installation on the wall

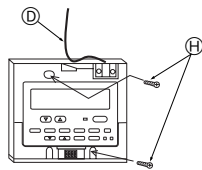

[Fig.8.2.1]

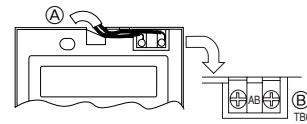

- (A) To TB5 on the unit
- (B) Terminal block representation
No polarity!

[Fig.8.2.2]

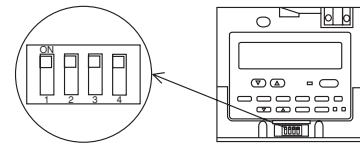

[Fig.8.3.1]

(1)

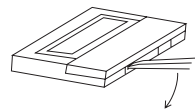

(2)

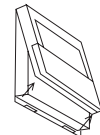

[Fig.8.4.1]

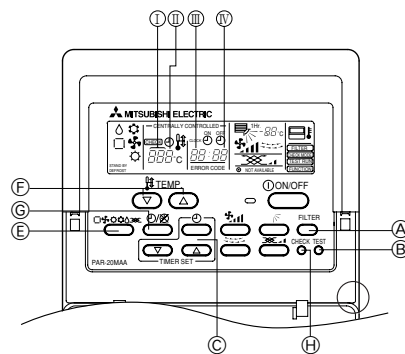

- (I) Mode number
- (II) Setting number
- (III) Refrigerant address
- (IV) Unit number

[Fig.8.4.2]

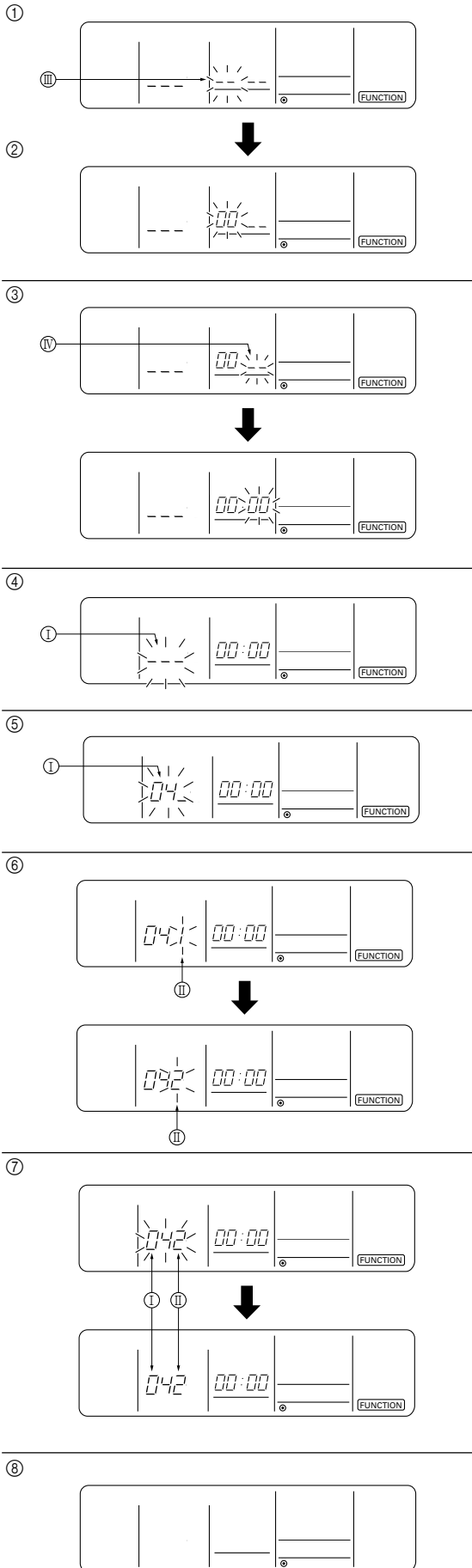

[Fig.8.4.3]

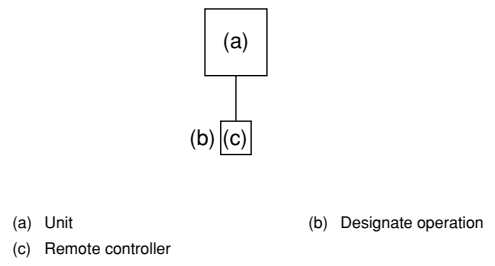

[Fig. 9.0.1]

(1) Normal Connecting

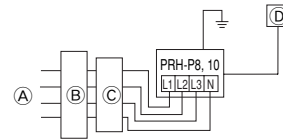

(2) Grouping (16 units)

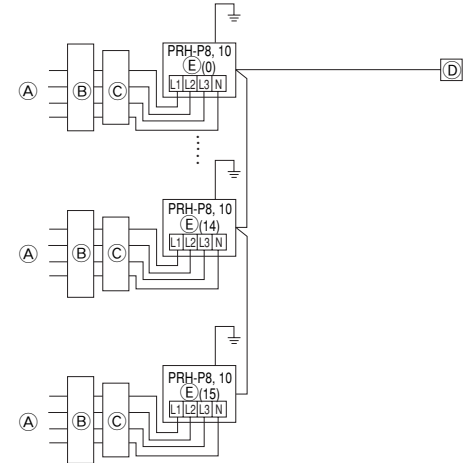

- Ⓐ Power supply
- Ⓑ Breaker
- Ⓒ Switch box
- Ⓓ Remote controller
- Ⓔ Address

[Fig. 9.1.1]

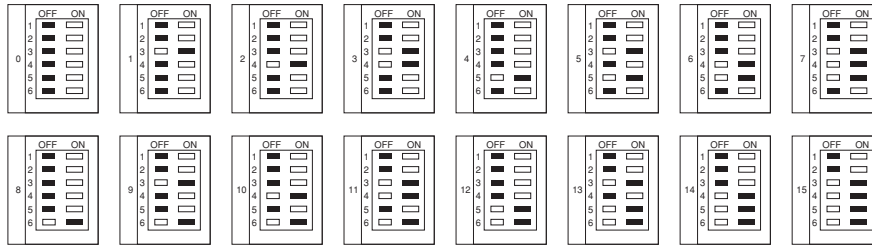

9.2

[Fig. 9.2.1]

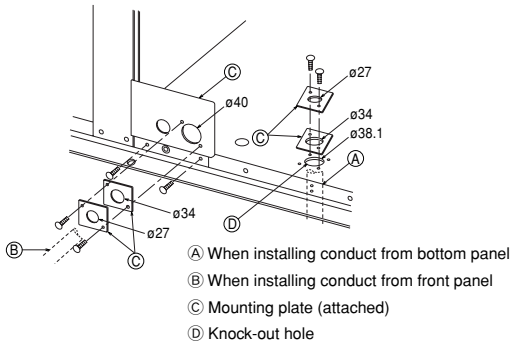

10

[Fig. 10.0.1]

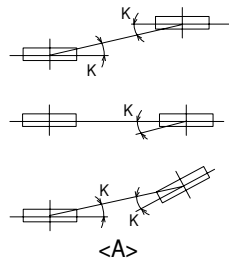

[Fig. 10.0.2]

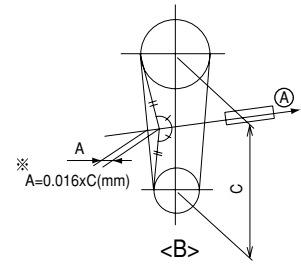

<A> Parallel degree of pulley
 Belt tension
 Ⓐ Flexion load (W)

11

[Fig. 11.0.1]

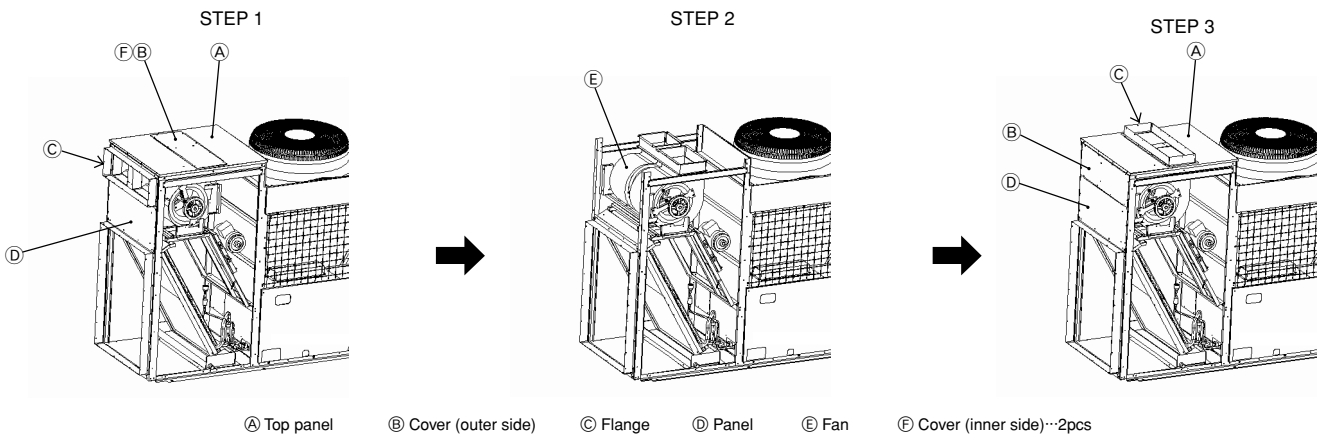

12

12.2

[Fig.12.2.1]

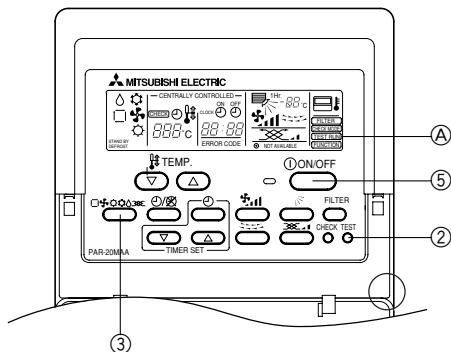

[Fig.12.2.2]

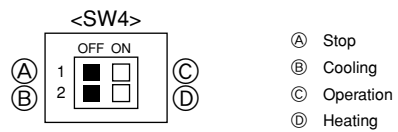

[Fig.12.3.1]

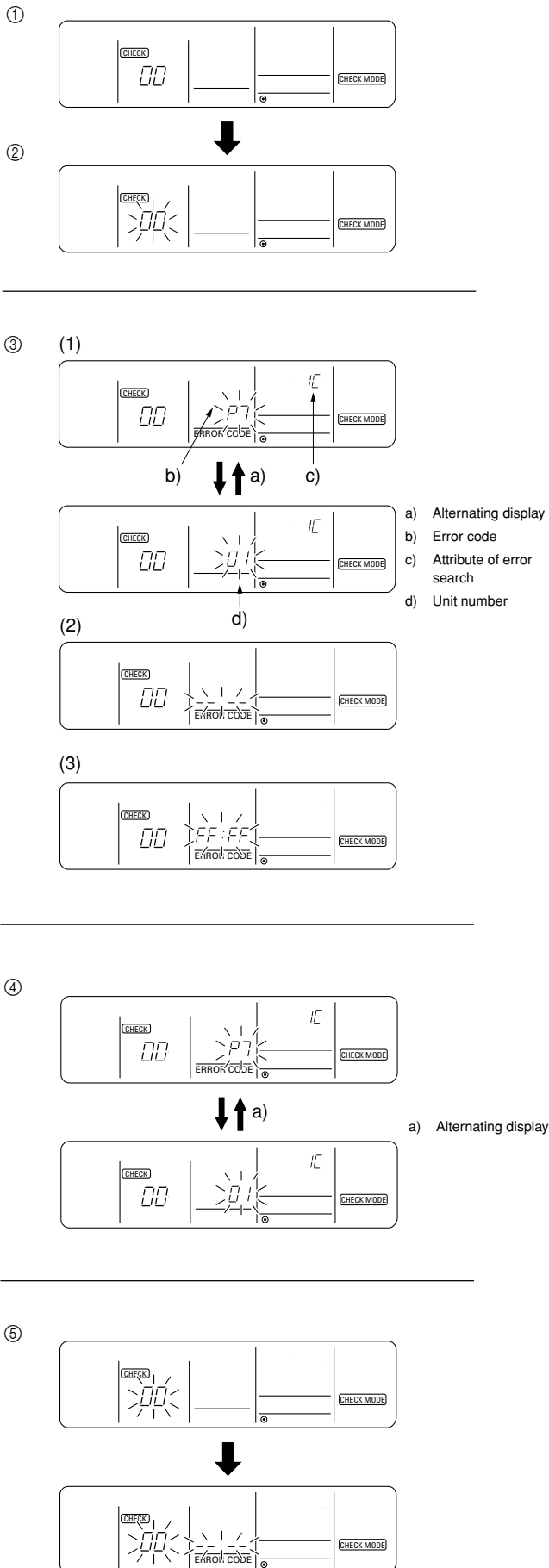

[Fig. 12.4.1]

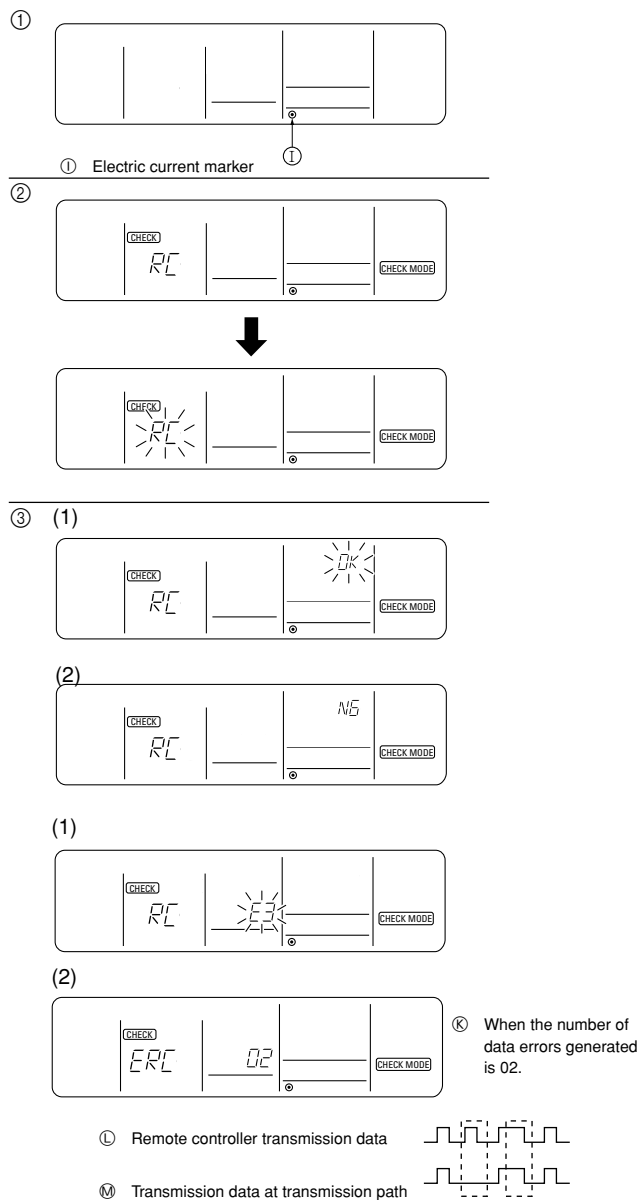

[Fig.14.1.1]

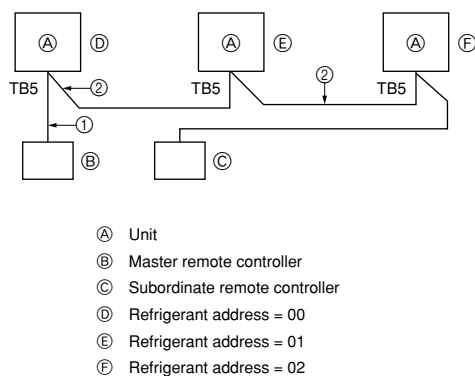

Contents

1. Safety precautions	8	8.3. Fitting the upper case	12
1.1. Before installation and electric work	8	8.4. Function settings	12
1.2. Precautions for devices that use R407C refrigerant	8	9. Electrical wiring	14
1.3. Before getting installed	9	9.1. Address settings	14
1.4. Before getting installed (moved) - electrical work	9	9.2. Wiring connection	14
1.5. Before starting the test run	9	10. Specifications for installing the belt	15
2. Unit accessories	9	11. Modification method of fan direction (From side flow to top flow)	15
3. Selecting an installation site	9	12. Test run	15
3.1. Space required around unit	9	12.1. Before test run	15
4. Lifting method and weight of product	10	12.2. Test run procedures	15
5. Installation of unit	10	12.3. Self-diagnosis	16
5.1. Installation	10	12.4. Remote controller diagnosis	17
6. Drain piping work	10	13. Troubleshooting	17
7. Duct work	10	13.1. How to handle problems with the test run	17
7.1. Fresh air inlet, duct installations, and operating restrictions	11	13.2. The following occurrences are not problems or errors	18
8. Remote controller	11	14. System control	18
8.1. Installing procedures	11	14.1. System settings	18
8.2. Connecting procedures	11	14.2. Examples of refrigerant system address setting	19

1. Safety precautions

1.1. Before installation and electric work

- ▶ Before installing the unit, make sure you read all the “Safety precautions”.
- ▶ The “Safety precautions” provide very important points regarding safety. Make sure you follow them.

Symbols used in the text





Warning:

Describes precautions that should be observed to prevent danger of injury or death to the user.

Caution:

Describes precautions that should be observed to prevent damage to the unit.

Symbols used in the illustrations

-  : Indicates an action that must be avoided.
-  : Indicates that important instructions must be followed.
-  : Indicates a part which must be grounded.
-  : Indicates that caution should be taken with rotating parts. (This symbol is displayed on the main unit label.) <Color: yellow>
-  : Beware of electric shock. (This symbol is displayed on the main unit label.) <Color: yellow>

Warning:

Carefully read the labels affixed to the main unit.

Warning:

- Ask the dealer or an authorized technician to install the air conditioner.
 - Improper installation by the user may result in water leakage, electric shock, or fire.
- Install the unit at a place that can withstand its weight.
 - Inadequate strength may cause the unit to fall down, resulting in injuries.
- Use the specified cables for wiring. Make the connections securely so that the outside force of the cable is not applied to the terminals.
 - Inadequate connection and fastening may generate heat and cause a fire.
- Prepare for strong winds and earthquakes and install the unit at the specified place.
 - Improper installation may cause the unit to topple and result in injury.
- Always use other accessories specified by Mitsubishi Electric.
 - Ask an authorized technician to install the accessories. Improper installation by the user may result in water leakage, electric shock, or fire.
- Never repair the unit. If the air conditioner must be repaired, consult the dealer.
 - If the unit is repaired improperly, water leakage, electric shock, or fire may result.
- Do not touch the heat exchanger fins.
 - Improper handling may result in injury.
- When handling this product, always wear protective equipment.
EG: Gloves, full arm protection namely boiler suit, and safety glasses.
 - Improper handling may result in injury.
- Install the air conditioner according to this Installation Manual.
 - If the unit is installed improperly, water leakage, electric shock, or fire may result.

- Have all electric work done by a licensed electrician according to “Electric Facility Engineering Standard” and “Interior Wire Regulations” and the instructions given in this manual and always use a special circuit.
 - If the power source capacity is inadequate or electric work is performed improperly, electric shock and fire may result.
- Securely install the unit terminal cover (panel).
 - If the terminal cover (panel) is not installed properly, dust or water may enter the unit and fire or electric shock may result.
- When re-charging the refrigerant circuit after installation or relocation of the unit, only use the specified refrigerant (R407).
 - If a different refrigerant or air is mixed with the original refrigerant, the refrigerant cycle may malfunction and the unit may be damaged.
- When moving and reinstalling the air conditioner, consult the dealer or an authorized technician.
 - If the air conditioner is installed improperly, water leakage, electric shock, or fire may result.
- Do not reconstruct or change the settings of the protection devices.
 - If the pressure switch, thermal switch, or other protection device is shorted and operated forcibly, or parts other than those specified by Mitsubishi Electric are used, fire or explosion may result.
- To dispose of this product, consult your dealer.
- The installer and system specialist shall secure safety against leakage according to local regulation or standards.
 - Following standards may be applicable if local regulation are not available.
- Pay a special attention to the place, such as a basement, etc. where refrigeration gas can stay, since refrigeration is heavier than the air.
- The appliance is not intended for use by young children or infirm persons without supervision.
- Young children should be supervised to ensure that they do not play with the appliance.

1.2. Precautions for devices that use R407C refrigerant

Caution:

- Use liquid refrigerant to fill the system.
 - If gas refrigerant is used to seal the system, the composition of the refrigerant in the cylinder will change and performance may drop.
- Do not use a refrigerant other than R407C.
 - If another refrigerant (R22, etc.) is used, the chlorine in the refrigerant may cause the refrigerator oil to deteriorate.
- Use a vacuum pump with a reverse flow check valve.
 - The vacuum pump oil may flow back into the refrigerant cycle and cause the refrigerator oil to deteriorate.
- Do not use the following tools that are used with conventional refrigerants.
(Gauge manifold, charge hose, gas leak detector, reverse flow check valve, refrigerant charge base, refrigerant recovery equipment)
 - If the conventional refrigerant and refrigerator oil are mixed in the R407C, the refrigerant may deteriorate.
 - If water is mixed in the R407C, the refrigerator oil may deteriorate.
 - Since R407C does not contain any chlorine, gas leak detectors for conventional refrigerants will not react to it.
- Do not use a charging cylinder.
 - Using a charging cylinder may cause the refrigerant to deteriorate.
- Be especially careful when managing the tools.
 - If dust, dirt, or water gets in the refrigerant cycle, the refrigerant may deteriorate.

1.3. Before getting installed

⚠ Caution:

- **Do not install the unit where combustible gas may leak.**
 - If the gas leaks and accumulates around the unit, an explosion may result.
- **Do not use the air conditioner where food, pets, plants, precision instruments, or artwork are kept.**
 - The quality of the food, etc. may deteriorate.
- **Do not use the air conditioner in special environments.**
 - Oil, steam, sulfuric smoke, etc. can significantly reduce the performance of the air conditioner or damage its parts.
- **When installing the unit in a hospital, communication station, or similar place, provide sufficient protection against noise.**
 - The inverter equipment, private power generator, high-frequency medical equipment, or radio communication equipment may cause the air conditioner to operate erroneously, or fail to operate. On the other hand, the air conditioner may affect such equipment by creating noise that disturbs medical treatment or image broadcasting.
- **Do not install the unit on a structure that may cause leakage.**
 - When the room humidity exceeds 80 % or when the drain pipe is clogged, condensation may drip from the indoor unit. Perform collective drainage work together with the outdoor unit, as required.

1.4. Before getting installed (moved) - electrical work

⚠ Caution:

- **Ground the unit.**
 - Do not connect the ground wire to gas or water pipes, lightning rods, or telephone ground lines. Improper grounding may result in electric shock.
- **The reverse phase of L lines (L1, L2, L3) can be detected (Error cord: 4103), but the reverse phase of L lines and N line can be not be detected.**
 - The some electric parts should be damaged when power is supplied under the miss wiring.
- **Install the power cable so that tension is not applied to the cable.**
 - Tension may cause the cable to break and generate heat and cause a fire.
- **Install a leak circuit breaker, as required.**
 - If an leak circuit breaker is not installed, electric shock may result.
- **Use power line cables of sufficient current carrying capacity and rating.**
 - Cables that are too small may leak, generate heat, and cause a fire.
- **Use only a circuit breaker and fuse of the specified capacity.**
 - A fuse or circuit breaker of a larger capacity or a steel or copper wire may result in a general unit failure or fire.

2. Unit accessories

- ① Conduit mounting plate × 3 ② Tapping screw M4 × 4 ③ Remote controller

3. Selecting an installation site

- Select a site with sturdy fixed surface sufficiently durable against the weight of unit.
- Before installing unit, the routing to carry in unit to the installation site should be determined.
- Select a site where the unit is not affected by entering air.
- Select a site where the flow of supply and return air is not blocked.
- Select a site which allows the supply air to be distributed fully in room.
- Do not install unit at a site with oil splashing or steam in much quantity.
- Do not install unit at a site where combustible gas may generate, flow in, stagnate or leak.
- Do not install unit at a site where equipment generating high frequency waves (a high frequency wave welder for example) is provided.
- Do not install unit at a site where fire detector is located at the supply air side. (Fire detector may operate erroneously due to the heated air supplied during heating operation.)
- When special chemical product may scatter around such as site chemical plants and hospitals, full investigation is required before installing unit. (The plastic components may be damaged depending on the chemical product applied.)

3.1. Space required around unit

[Fig. 3.1.1] (P.2)

- <A> Top view Side view
Ⓐ Front Ⓑ Must be open
Ⓒ Wall height (H)
L1: 450 L2: 250

- **Do not wash the air conditioner units.**
 - Washing them may cause an electric shock.
- **Be careful that the installation base is not damaged by long use.**
 - If the damage is left uncorrected, the unit may fall and cause personal injury or property damage.
- **Install the drain piping according to this Installation Manual to ensure proper drainage. Wrap thermal insulation around the pipes to prevent condensation.**
 - Improper drain piping may cause water leakage and damage to furniture and other possessions.
- **Be very careful about product transportation.**
 - Only one person should not carry the product if it weighs more than 20 kg.
 - Some products use PP bands for packaging. Do not use any PP bands for a means of transportation. It is dangerous.
 - Do not touch the heat exchanger fins. Doing so may cut your fingers.
 - When transporting the outdoor unit, suspend it at the specified positions on the unit base. Also support the outdoor unit at four points so that it cannot slip sideways.
- **Safely dispose of the packing materials.**
 - Packing materials, such as nails and other metal or wooden parts, may cause stabs or other injuries.
 - Tear apart and throw away plastic packaging bags so that children will not play with them. If children play with a plastic bag which was not torn apart, they face the risk of suffocation.

1.5. Before starting the test run

⚠ Caution:

- **Turn on the power at least 12 hours before starting operation.**
 - Starting operation immediately after turning on the main power switch can result in severe damage to internal parts. Keep the power switch turned on during the operational season.
- **Do not touch the switches with wet fingers.**
 - Touching a switch with wet fingers can cause electric shock.
- **Do not touch the refrigerant pipes during and immediately after operation.**
 - During and immediately after operation, the refrigerant pipes are may be hot and may be cold, depending on the condition of the refrigerant flowing through the refrigerant piping, compressor, and other refrigerant cycle parts. Your hands may suffer burns or frostbite if you touch the refrigerant pipes.
- **Do not operate the air conditioner with the panels and guards removed.**
 - Rotating, hot, or high-voltage parts can cause injuries.

(1) Basic space required

A space of at least 250 mm is necessary at the back for inlet air. Taking servicing, etc. from the rear into account, a space of about 450 mm should be provided, the same as at the front.

(2) When there is an obstruction above the unit

(3) When unit is surrounded by walls

Note:

- **Wall heights (H) of the front and the back sides shall be within overall height of unit.**
- **If the panel height is exceeded, add the "h" dimension of the Fig. 3.1.1 to L1 and L2.**

L1: 450 L2: 250

Example: When h is 100,
the L1 dimension becomes 450 + 100 = 550 mm.

(4) Continuous installation

- Space required for collective installation and continuous installation:
When installing several units, leave the space between each unit considering passage for air and people.
- Open in the two directions.
- In case wall height (H) exceeds overall height of unit, add "h" dimension (h = wall height <H> – overall height of unit) to * marked dimension.

4. Lifting method and weight of product

[Fig. 4.0.1] (P.2)

⚠ Caution:

- **Be very careful to carry product.**
 - Do not have only one person to carry product if it is more than 20 kg.
 - PP bands are used to pack some products. Do not use them as a mean for transportation because they are dangerous.
 - Do not touch heat exchanger fins with your bare hands. Otherwise you may get a cut in your hands.
 - Tear plastic packaging bag and scrap it so that children cannot play with it. Otherwise plastic packaging bag may suffocate children to death.
 - When carrying in outdoor unit, be sure to support it at four points. Carrying in and lifting with 3-point support may make outdoor unit unstable, resulting in a fall of it.
- **Protect the corners on the unit that come in contact with the sling with padding.**

5. Installation of unit

5.1. Installation

[Fig. 5.1.1] (P.2)

- Ⓐ M10 anchor bolt procured at the site. Ⓑ Corner is not seated.

- Fix unit tightly with bolts so that unit will not fall down due to earthquake or gust.
- Use concrete or angle for foundation of unit.
- Vibration may be transmitted to the installation section and noise and vibration may be generated from the floor and walls, depending on the installation conditions. Therefore, provide ample vibrationproofing (cushion pads, cushion frame, etc.).
- Be sure that the corners are firmly seated. If the corners are not firmly seated, the installation feet may be bent.

⚠ Warning:

- **Be sure to install unit in a place strong enough to withstand its weight. Any lack of strength may cause unit to fall down, resulting in a personal injury.**
- **Have installation work in order to protect against a strong wind and earthquake. Any installation deficiency may cause unit to fall down, resulting in a personal injury.**

When building the foundation, give full attention to the floor strength, drain water disposal <during operation, drain water flows out of the unit>, and wiring routes.

Down wiring precautions

When down wiring are performed, be sure that foundation and base work does not block the base through holes.

[Fig. 5.1.2] (P.2)

- Ⓐ Bottom wiring through hole Ⓑ (bolt hole)

6. Drain piping work

[Fig. 6.0.1] (P.2)

- Ⓐ Drain piping Ⓑ Socket R1
Ⓒ Drain trap
Ⓓ The drain pipe should extend below this level.
Ⓔ $\geq 2 \times$ External static pressure
Ⓕ $\geq 2 \times$ Ⓔ

1. The condensate drain socket (R1) is provided. The drain pipe is connected to the drain socket.
2. The drain pipe must be provided with a trap on the outside of the unit and also installed at an incline for proper drainage, as shown [Fig. 6.0.1] (P.2).
3. To prevent dew condensation and leakage, provide drain pipes with insulation.
4. Upon completion of the piping work, check that there is no leakage and that the water drains off properly.

7. Duct work

1. In case of side flow unit (factory setting) is equipped with horizontal supply and return air openings. Duct connection to the unit should be made with duct flanges and secured directly to the air openings with flexible duct connectors to avoid normal noise transmission.
2. For vertical air supply, a field supply plenum should be used. The figure below shows the recommended method for duct connection.
3. In case of top flow unit (modified when installed) is equipped with vertical supply and horizontal return air openings. Duct connection to the unit should be made with duct flanges and securely attached to the air openings with flexible duct connectors.
4. To prevent air leakage, all duct seams should be taped. Ducts run in air spaces that are not air-conditioned must be insulated and provided with a vapor barrier. Ducts exposed to the outside must be weather proofed. For quiet operation, we recommend that the insulation on the supply duct be placed inside, lining the duct.
5. Where ducts from the outside enter a building, the duct openings in the building should be sealed with weather stripping to prevent rain, duct, sand, etc. from entering the building.
6. Fans will not accept any external resistance to airflow and what provision is available if ductwork is to be fitted to the external fans.
7. Correctly sized filters must be fitted and there is no provision within the unit, however the filters (field supply) may be installed in the return air.
8. Duct earth wiring must be connected to the earth point of unit (⚡ mark point).

[Fig. 7.0.1] (P.3)

- <A> Ex. Side flow
 Ex. Top flow
- Ⓐ Duct Ⓑ Roof curb
Ⓒ Single duct divider Ⓓ Plenum divider
Ⓔ Insulator Ⓕ Keep duct-work length 850 or more
Ⓖ Rainproof the part where the duct flange is screwed on (Top flow only).

⚠ Caution:

- **Outlet duct is 850 mm or more necessary to construct.**
- **To connect the air conditioner main body and the duct for potential equalization.**
- Mount holes for outlet duct flange and inlet duct.

[Fig. 7.0.2] (P.3)

- <A> In case of side flow
 In case of top flow
- Ⓐ Inlet duct flange Ⓑ Outlet duct flange
Ⓒ Same as inlet and outlet duct flange Ⓓ 2×100 pitch = 200
Ⓔ 28- ϕ 3 holes (Inlet duct mount holes) Ⓕ 18- ϕ 3 holes (Outlet duct mount holes)

7.1. Fresh air inlet, duct installations, and operating restrictions

This unit has an fresh air inlet on each side of the unit. Use the one that suits a particular application.

[Fig. 7.1.1] (P.3)

- Ⓐ Fresh air inlet (on both sides)

⚠ Caution:

- ① Properly seal duct connections.
- ② Install a proper size filter at the opening of the inlet, and clean the filter on a regular basis.
- ③ Install a duct longer than 850 mm or block the opening of the inlet with a wire net to keep hands out of the inlet.

- ④ The opening of the connected duct must not be facing up as rain or snow will enter the duct.
- ⑤ Be sure that the temperature of the mixed air (return air and outside air) falls within the following ranges:
In the case of cooling operation: mixed air temperature 15 °CWB - 24 °CWD (30 - 80% RH)
In the case of heating operation: mixed air temperature 15 °CDB - 32 °CDB
- ⑥ Install a reverse air-flow prevention plate inside return and supply ducts to prevent the back flow of air during unit stoppage.

[Fig. 7.1.2] (P.3)

- Ⓐ Filter (Field supply)
- Ⓑ Fresh air inlet duct (Field supply)

8. Remote controller

8.1. Installing procedures

- (1) Select an installing position for the remote controller (switch box).
Be sure to observe the following precautions.

[Fig. 8.1.1.(1)] (P.4)

- Ⓐ Remote controller profile
- Ⓑ Required clearances surrounding the remote controller
- Ⓒ Temperature sensor
- Ⓓ Installation pitch

- ① The temperature sensors are located on both remote controller and unit. To use the temperature sensor on the remote controller, mainly use the remote controller for temperature setting or room temperature detection. Install the remote controller in such an area that can detect average room temperatures, free of direct sunlight, airflow from the air conditioner, and other such heating source.
- ② In either case when the remote controller is installed in the switch box or on the wall, provide the clearances indicated in the diagram. (When the schedule timer is used in combination, also refer to the installation manual supplied with the schedule timer.)

Note:

Check that there is no electric wire left close to the remote controller sensor. If any electric wire is near the sensor, the remote controller may fail to detect a correct room temperature.

- ③ Procure the following parts locally:
Switch box for two pieces
Thin copper conduit tube
Lock nuts and bushings

- (2) Seal the service entrance for the remote controller cord with putty to prevent possible invasion of dew drops, water, cockroaches or worms.

<A> For installation in the switch box:

- When the remote controller is installed in the switch box, seal the junction between the switch box and the conduit tube with putty.

 For direct installation on the wall select one of the following:

- Prepare a hole through the wall to pass the remote controller cord (in order to run the remote controller cord from the back), then seal the hole with putty.
- Run the remote controller cord through the cut-out upper case, then seal the cut-out notch with putty similarly as above.

B-1. To lead the remote controller cord from the back of the controller:

B-2. To run the remote controller cord through the upper portion:

[Fig. 8.1.1.(2)] (P.4)

- Ⓒ Wall
- Ⓓ Conduit
- Ⓔ Lock nut
- Ⓕ Bushing
- Ⓖ Switch box
- Ⓗ Remote controller cord
- Ⓘ Seal with putty

- (3) Install the lower case in the switch box or on the wall.

[Fig. 8.1.1.(3)] (P.4)

<A> For installation in the switch box

- Ⓒ Switch box for two pieces
- Ⓓ Remote controller cord
- Ⓔ Cross-recessed, pan-head screw
- Ⓕ Seal the remote controller cord service entrance with putty

 For direct installation on the wall

- Ⓗ Wood screw

⚠ Caution:

Do not over-tighten the screws to possible deformed or broken lower case.

Note:

- Select a flat place for installation.
- Be sure to use two or more locations for securing of the remote controller in the switch box or on the wall.

8.2. Connecting procedures

- The remote controller cord may be extended up to 500 m. Since the remote controller cord supplied with the unit is 10 m-long, use those electric wires or (two-core) cables of 0.3 mm² to 1.25 mm² for extension. Do not use multi-conductor cables to prevent possible malfunction of the unit.

- (1) Connect the remote controller cord to the terminal block for the lower case.

[Fig. 8.2.1] (P.4)

- Ⓐ To TB5 on the unit
- Ⓑ Terminal block representation
No polarity!

⚠ Caution:

Do not use crimp-style terminals for connection to the remote controller terminal block to eliminate contact with the boards and resultant trouble.

- (2) Set the dip switch No.1 shown below when using two remote controller's for the same group.

[Fig. 8.2.2] (P.4) Dip switches

Setting the dip switches

The dip switches are at the bottom of the remote controller. Remote controller Main/Sub and other function settings are performed using these switches. Ordinarily, only change the Main/Sub setting of SW1. (The factory settings are all "ON".)

<SW No. 1>

SW contents Main	Remote controller Main/Sub setting
ON/OFF	Main/Sub
Comment	Set one of the two remote controllers at one group to "Main"

<SW No. 2>

SW contents Main	When remote controller power turned on
ON/OFF	Normally on/Timer mode on
Comment	When you want to return to the timer mode when the power is restored after a power failure when a Program timer is connected, select "Timer mode".

<SW No. 3>

SW contents Main	Cooling/heating display in AUTO mode
ON/OFF	Yes/No
Comment	When you do not want to display "Cooling" and "Heating" in the Auto mode, set to "No".

<SW No. 4>

SW contents Main	Intake temperature display
ON/OFF	Yes/No
Comment	When you do not want to display the intake temperature, set to "No".

8.3. Fitting the upper case

[Fig. 8.3.1] (P.4)

- (1) Put the upper latches (at two locations) first then fit the upper case into the lower case as illustrated.
- (2) To remove the upper case, put a slotted screwdriver tip in the latches as shown in the diagram then move the screwdriver in the direction of arrow.

⚠ Caution:

- Do not move the screwdriver while inserting the tip far into the latches to prevent broken latches.
- Be sure to put the screwdriver tip securely in the latches until a snap sounds. Loosely inserted screwdriver may fall down.

Note:

The operating section is covered with a protective sheet. Before using the unit, remember to remove the protective sheet.

8.4. Function settings

(1) Wired type

[Fig. 8.4.1] (P.4)

- | | |
|-----------------------|------------------|
| ① Mode number | Ⓜ Setting number |
| Ⓜ Refrigerant address | Ⓜ Unit number |

Changing the power voltage setting

Be sure to change the power voltage setting when operating the unit in an area where the power source is 220 V or 230 V.

(The power voltage setting is set to 240 V at the factory. Units that are used in areas where the power source is 240 V do not require power voltage setting changes.)

[Operating instructions] (entering settings with a wired remote controller)

[Fig. 8.4.2] (P.5)

① Go to the function setting mode

Switch OFF the remote controller.

Press the **A** FILTER and **B** TEST RUN buttons simultaneously and hold them for at least 2 seconds. FUNCTION will start to flash. The refrigerant address display will start to flash momentarily.

② Setting the refrigerant address

Use the **C** **▲** **▼** (TIMER SET) button to set the refrigerant address **Ⓜ** to 00. Press **▲** to increase the value or **▼** to decrease it.

00 is the typical setting. When operating in a group configuration, use the correlating refrigerant address (see the technical manual for details on setting the refrigerant address for a group). The refrigerant addresses must be set in order when performing the following operation.

- * If the unit stops two seconds after the FUNCTION display starts to flash or [88] starts to flash in the room temperature display, a transmission problem may have occurred. Check to see if there is some source of transmission interference (noise) nearby.

If you make a mistake during any point of this procedure, you can quit the function setting mode by pressing **Ⓜ** once and then return to step **①**.

③ Setting the unit number

Press **Ⓜ** (CLOCK ON OFF) and [-] will start to flash in the unit number **Ⓜ** display.

Use the **C** **▲** **▼** (TIMER SET) button to set the unit number to 00. Press **▲** to increase the value or **▼** to decrease it.

Unit number 00 = the function setting selection for the entire refrigerant system

④ Setting the refrigerant address/unit number

Press the **E** MODE button to designate the refrigerant address/unit number. [-] will flash in the mode number **○** I display momentarily.

- * If [88] appears in the room temperature section, the selected refrigerant address does not exist in the system. Also, if [F] appears in the unit number display section, the selected unit number does not exist. Enter the correct refrigerant address and unit number at steps **②** and **③**.

Fan draft operation will start when settings are confirmed using the **E** MODE button. You can also use this operation to find out what functions are assigned to which unit numbers and the locations of those units. Note that the fan draft operation will start for all of the units that have been assigned refrigerant addresses when 00 or AL is the assigned unit number.

- * If a unit other than those designated with refrigerant addresses emits a fan draft when a different refrigerant grouping is being used, the set refrigerant addresses have probably overlapped. Reassign the refrigerant addresses at the DIP switch of the unit.

Example) When the refrigerant address is set to 00 and the unit number is 02.

[Fig. 8.4.3] (P.5)

- | | |
|-----------------------|-------------------------|
| (a) Unit | (b) Designate operation |
| (c) Remote controller | |

⑤ Selecting the mode number

Press the **F** **▲** **▼** (TEMP) buttons to set the mode number **①** to 04. Press **▲** to increase the value or **▼** to decrease it.

① Mode number 04 = power voltage switching mode

⑥ Selecting the setting number

1 will start to flash as the currently specified setting number **Ⓜ** when the **Ⓜ** button **Ⓜ** is pressed. Use the **▲** **▼** (TEMP) buttons to specify 2 as the setting number. Press **▲** to increase the value or **▼** to decrease it.

Ⓜ Setting number 1 = 240 V

Ⓜ Setting number 2 = 220 V/230 V

⑦ Designating the mode and setting numbers

The mode and setting numbers **①** **Ⓜ** will start to flash when the MODE button **E** is pressed and the designation operation will begin. The numbers are set when the flashing settings stay lit.

- * If [-] appears in the room temperature display as the mode/setting number, or if a flashing [88] display appears, a transmission problem may have occurred. Check to see if there is some source of transmission interference (noise) nearby.

⑧ Complete function selection

Press the FILTER **A** and TEST RUN **B** buttons simultaneously for at least two seconds. The function selection screen will disappear momentarily and the air conditioner OFF display will appear.

- * Do not use the remote controller for 30 seconds after completing the function selection.

Other function selections

Now that you know how to change the power voltage setting, there are several other settings that can be changed as well. The following Table lists the various settings that can be changed through the remote controller and the default settings of the unit.

Table 1. Default setting

Function	Settings	Mode no.	Setting no.	Default settings	Table no.
Power failure automatic recovery	Not available	01	1	○	Table 2
	Available		2		
Indoor temperature detection	Unit operating average	02	1	○	
	Set by unit's remote controller		2		
	Remote controller's internal sensor		3		
LOSSNAY connectivity	Not supported	03	1	○	
	Supported (unit is not equipped with outdoor-air intake)		2		
	Not supported (unit is equipped with outdoor-air intake)		3		
Power voltage	240 V	04	1	○	
	220 V, 230 V		2		
Filter sign	100 Hr	07	1		Table 3
	2500 Hr		2		
	No filter sign indicator		3	○	
Fan operation during thermo off in heating operation	Operation	25	3	○	
	Stop		2		

Things to remember when entering function selections:

The basic procedure for entering function selections is the same as described for switching between power voltages. However, there are some differences at step ③ for selecting the unit number, step ⑤ for selecting the mode number and step ⑥ for selecting the setting number. The following Tables 2 and 3 list the various function settings, mode numbers and setting numbers. Table 2 details the functions of the entire refrigerant system while Table 3 shows the functions that can be set for the unit.

Table 2. Itemized functions of the entire refrigerant system (select unit number 00)

Function	Settings	Mode no.	Setting no.	Check	Remarks
Power failure automatic recovery	Not available	01	1		Approx. 4-minute wait-period after power is restored.
	Available		2		
Indoor temperature detection	Unit operating average	02	1		
	Set by unit's remote controller		2		
	Remote controller's internal sensor		3		
LOSSNAY connectivity	Not Supported	03	1		
	Supported (unit is not equipped with outdoor-air intake)		2		
	Supported (unit is equipped with outdoor-air intake)		3		
Power voltage	240 V	04	1		
	220 V, 230 V		2		

Table 3. Itemized functions of the unit (select unit numbers 01 to 03 or AL)

Function	Settings	Mode no.	Setting no.	Check	Remarks
Filter sign	100 Hr	07	1		
	2500 Hr		2		
	No filter sign indicator		3		
Fan operation during thermo off in heating operation	Operation	25	3		When selecting fan operation "Stop", set setting no. of Mode no. "02" in Table 2 to "3". Be sure to place the remote controller inside the room to be air-conditioned so that it can monitor the room temperature.
	Stop		2		

③ Setting the unit numbers

Set "00" as the unit number when setting functions from Table 2.

When setting functions from Table 3:

- When setting functions for a unit in an independent system, set the unit number to 01.

⑤ Selecting the mode number

Select from Table 2 and Table 3.

⑥ Selecting the setting number

Select from Table 2 and Table 3.

9. Electrical wiring

Precautions on electrical wiring

⚠ Warning:

- Electrical work should be done by qualified electrical engineers in accordance with "Engineering Standards For Electrical Installation" and supplied installation manuals. Special circuits should also be used. If the power circuit lacks capacity or has an installation failure, it may cause a risk of electric shock or fire.
 - Always use the designated cable for wiring, and connect it correctly. Secure it so that the cable applies no external pressure to the terminal connection. If the connection is faulty or the cable is not fully secured, overheating or fire could result.
 - Be sure to use specified cables and connect them firmly so that no external wiring force is exerted on terminal connections. Loose connections may cause heat or fire.
- Be sure to take power from the special branch circuit.
 - Be sure to install an earth leakage breaker to the power.
 - Install the unit to prevent that any of the control circuit cables (remote controller) is brought in direct contact with the power cable outside the unit.
 - Ensure that there is no slack on all wire connections.
 - Remote controller cable above the ceiling may be bitten by mice. Use as many metal pipes as possible to insert the cable into them for protection. Where the remote controller cable is exposed, protect the cable by running it through a metal pipe.
 - Never connect the power cable to leads for the remote controller cables. Otherwise the cables would be broken.
 - Fix power source wiring to control box by using buffer bushing for tensile force (PG connection or the like).
 - Set up the unit so that the wiring for the remote controller and the M-NET (MELANS) wiring do not produce electrical interference with the power supply cable. (Do not route them together in the same conduit.)
 - Be sure to provide designated grounding work to the unit.
 - Give some allowance to wiring for electrical part box of the unit, because the box is sometimes removed at the time of service work.

⚠ Caution:

- Be sure to put the unit to the ground on the outdoor unit side. Do not connect the earth cable to any gas pipe, water pipe, lightning rod, or telephone earth cable. Incomplete grounding may cause a risk of electric shock.
- Some installation sites may require installation of an earth leakage breaker. Failure to install it may result in an electric shock.
- Always use an earth leakage breaker and fuse with the specified capacity. Use of a fuse with a capacity larger than that specified, or use of a piece of wire or copper wire may cause breakdown or fire.
- Depending on the location of the unit, a current leakage breaker may be required. If a current leakage breaker is not installed, electric shock could result.
- Do not use breakers or fuses with a capacity different from the correct one. If large-capacity fuses, wire, or copper wiring are used, accident or fire may result.

The following table is an example. The selection of other capacities should be determined in accordance with the relevant standards.

[Wiring example] (For metal pipe)

	Power Cable	Breaker Capacity	Fuse	Remote controller cable	Grounding wire	Max. Permissible system impedance *1
PRH-P8MYA	10 mm ² or thicker	63 A	63 A	Cable or wire of 0.3 ~ 1.25 mm ²	10 mm ² or thicker	0.07 Ω
PRH-P10MYA	10 mm ² or thicker	63 A	63 A		10 mm ² or thicker	0.05 Ω

Note:

*1: This device is intended for the connection to a power supply system with a maximum permissible system impedance ZMAX of 0.07 Ω: PRH-P8, 0.05 Ω: PRH-P10 at the interface point (power service box) of the user's supply.

The user has to ensure that this device is connected only to a power supply system which fulfills the requirement above.

If necessary, the user can ask the public power supply company for the system impedance at the interface point.

[Selecting earth leakage breaker (NV)]

To select NF or NV instead of a combination of Class B fuse with switch, use the following:

Fuse (class B)	63 A
Earth leakage breaker ELB (with over-load protection)	NV-100SW 60 A 100 mA 0.1s or less

NV is a product name of MITSUBISHI.

- Power supply cords of appliances shall not be lighter than design 245 IEC57.
- A switch with at least 3 mm contact separation in each pole shall be provided by the Air conditioner installation.

Example

[Fig. 9.0.1] (P.5)

- (1) Normal Connecting
 (2) Grouping (16 units)
- Ⓐ Power supply Ⓑ Breaker Ⓒ Switch box
 Ⓓ Remote controller Ⓔ Address

[Unit-MAA remote controller cable/cord] (For metal pipe)

	MAA remote controller
Types of cable/cord	When extending the remote controller cable, remote controller cables shall not be lighter than design 245 IEC53.
Number of cable/cord	2 core cable
Diameter of cable/cord	0.3 ~ 1.25 mm ²
Total extension	Max. 200 m

9.1. Address settings

Unit address settings

- During address setting, set all the dip switches SW1 (3 - 6) on the outdoor-side controller board to <when shipped from factory: all OFF>. (Address setting is not necessary for 1:1 or Free multi-component systems.)
- Functions of SW1 according to switch setting are shown below.
- To control a group of units, address must be assigned to each unit.

(SW1 of outdoor-side controller)

SW1 function switching	Model	Functions according to switch setting	
		ON	OFF
1	-	-	-
2	Error history clear	Clear	Ordinary
3	Refrigerant system address setting	Unit address Settings 0 - 15	
4	↑		
5	↑		
6	↑		

[Fig. 9.1.1] (P.6)

9.2. Wiring connection

- Using the conduit mounting plates
 Conduit mounting plates are supplied in three sizes (ø27, ø34, ø40). Use the mounting plate that fits the outer diameter of the wire to be used.

[Fig. 9.2.1] (P.6)

- Ⓐ When installing conduct from bottom panel
- Ⓑ When installing conduct from front panel
- Ⓒ Mounting plate (attached)
- Ⓓ Knock-out hole

10. Specifications for installing the belt

1. Set the parallel angle of the fan and the motor pulley as shown in the [Fig. 10.0.1] and table 1.
2. Set the tension of the per one belt when the flexion load is within the range as shown in the [Fig. 10.0.2] and table 2 below at the proper flexion.
3. Adjust the suitable tension after the belt sit properly across the pulley (after more 24 - 28 hours working).
When the new belt is used, adjust the suitable tension about the 1.3 times of the maximum value of the flexion load.
4. Readjust the belt every 2,000 hours after the first adjustment.
Exchange the belt when the belt's surroundings length has expanded by 2 % including the first expansion of the belt. (about 1 %)
(about 8,000 hours converted working time)
When selecting fan operation "Stop" (Mode no. 25 "2" in table 3 of page 13), readjust the belt every 1,000 hours after the first adjustment.

table 1

pulley	parallel angle	K (°)	note
		10 or less	gap of 3 mm every 1 m

table 2

type	pulley		Flexion load W (N)
	smaller out diameter (mm)		
B	~ 135		22 ~ 29
	136 ~ 160		27 ~ 34
	161 ~		29 ~ 37

[Fig. 10.0.1] / [Fig. 10.0.2] (P.6)

- <A> Parallel degree of pulley
- Belt tension
- Ⓐ Flexion load (W)

11. Modification method of fan direction (From side flow to top flow)

This product can be changed from side flow to top flow in the field. Modify if necessary as follows.

[Fig. 11.0.1] (P.6)

- Ⓐ Top panel
- Ⓑ Cover (outer side)
- Ⓒ Flange
- Ⓓ Panel
- Ⓔ Fan
- Ⓕ Cover (inner side)···2pcs

- ① Remove the top panel Ⓐ, cover (outer side) Ⓑ, flange Ⓒ, panel Ⓓ and cover (inner side) Ⓔ. (STEP 1)
- ② Modify the fan Ⓔ direction. (STEP 2)
- ③ Re-install the top panel Ⓐ, cover Ⓑ, flange Ⓒ and panel Ⓓ. (STEP 3)

Note:
In the case of top flow, the inner cover Ⓔ is not necessary.

12. Test run

12.1. Before test run

The test run can be carried out either from the unit or remote controller.

1. Checklist

- After wiring of units are complete, check that refrigerant is not leaking, the power and control wires are not loose, and the poles are not reversed.
- Use a 500 V insulation resistance tester to make sure that the resistance between the power terminal and the ground is 1.0 MΩ or more. If it is less than 1.0 MΩ, do not operate the unit.
- Make sure there is no malfunction in the unit. (If there is a malfunction, you can diagnose it using LED1 on the outdoor-side controller board.)
- Check the electrical power phase. If the phase is reversed, the fan may rotate in the wrong direction or stop, or unusual sounds may be produced.
- Starting at least 12 hours before the test run, send current through the crankcase heater. (If the current is running for a shorter period of time, damage to the compressor could result.)
- For specific models requiring changing of settings for selection of power supply ON/OFF capability, make proper changes referring to the description for Selection of Functions through Remote Controller.

After the above checks are complete, carry out the test run as indicated in the following outline.

12.2. Test run procedures

1) Remote controller

[Fig. 12.2.1] (P.6)

Operating procedures

① Turn on the main power supply

While the room temperature display on the remote controller reads "CENTRALLY CONTROLLED", the remote controller is disabled. Turn off the "CENTRALLY CONTROLLED" display before using the remote controller.

② Press "TEST RUN" button twice

- Ⓐ The "TEST RUN" indicator should light up.

③ Press button

Cooling mode: Cool air should start to blow.
Heating mode: Warm air should start to blow (after a while).

④ Press button

Check for correct motion of auto-vanes.

⑤ Check the outdoor-side fan for correct running

The unit features automatic capacity control to provide optimum outdoor-side fan speeds. The fan keeps running at a low speed to meet the current outside air condition unless it exceeds its available maximum power. Then, in actuality, the fan may stop or run in the reverse direction depending on the outside air, which does not mean malfunction.

⑥ Press the "ON/OFF" button to reset the test run in progress

- The test run will be automatically shut down after two hours in response to the AUTO STOP setting of two hours on the timer.
- During the test run, the room temperature display shows the unit indoor-side liquid piping temperatures.
- In the case of the test run, the OFF timer will activate, and the test run will automatically stop after two hours.
- The room temperature display section shows the control temperature for the units during the test run.
- Check that the units are running properly operation.
Malfunctions may not be displayed even if the wiring is incorrect.

(*1)

After turning ON the power, the system will go into startup mode, and the remote controller operation lamp (red) and the room temperature display section's "H0" will flash. Also, in the case of the indoor-side controller board substrata LEDs, LED 1 and LED 2 light up (when address is 0) or become dim (when address is not 0), and LED 3 flashes. In the case of the outdoor-side controller board substrata LED 1 display, and are displayed alternately at 1-second intervals.

- If one of the above operations does not function correctly, the following causes should be considered, and if applicable, dealt with. (The following symptoms have been determined under test run mode. Note that "startup" in the chart means the *1 display above.)

Symptoms		Cause
Remote Controller Display	Outdoor Substrate LED Display	
Remote controller is displaying "H0", and operation is not possible.	After "startup" display, "00" is displayed (correct operation).	• After power is turned ON, system startup lasts for about 2 mins., and "H0" is displayed (correct operation).
After power is turned ON, "H0" is displayed for 3 mins., then error code is displayed.	After "startup" display, error code is displayed.	• Outdoor-side unit's safeguard installation connector is open.
	After "startup" display, "F1" (negative phase) is displayed.	• Negative phase and open phase of outdoor unit's power terminal board (Single phase: L, N, ⊕/triple phase: L1, L2, L3, N, ⊕)
Power is turned ON, and "EE" or "EF" are displayed after "H0" is displayed.	After "startup" display, "00" or "EE" is displayed ("EE" is displayed when a test run is made).	• Incorrect connection of outdoor terminal board (Single phase: L, N, ⊕/triple phase: L1, L2, L3, N, ⊕ grounding and S1, S2, S3)
Display messages do not appear even when remote controller operation switch is turned ON (operation lamp does not light up).	After "startup" display, "EA" (error for number of units) or "Eb" (unit number error) is displayed.	• Unit construction differ
	After "startup" display, "00" is displayed (correct operation).	• Wiring for the unit is not connected correctly. (Polarity is wrong for S1, S2, S3)
	After "startup" display, "00" is displayed (correct operation).	• Remote controller transmission wire short
Operation display appears but soon disappears even when remote controller operations are executed.	After "startup" display, "00" is displayed (correct operation).	• There is no unit for address 0 (address is something other than 0).
		• Remote controller transmission wire burnout
		• After cancellation of function selection, operation is not possible for about 30 secs. (correct operation).

* Press the remote controller's "CHECK" button twice consecutively to be able to run a self diagnosis. See the chart below for content of error code displays.

LCD	Nonconformity Content	LCD	Nonconformity Content	LCD	Nonconformity Content
P1	Suction sensor error	P8	Pipe temperature error	E6 - EF	Signal error between indoor-side controller board and outdoor-side controller board
P2	Piping (liquid pipe) sensor error	P9	Piping (2-phase pipe) sensor error		
P4	Drain sensor error	U0 - UP	Unit nonconformity	- - -	No error history
P5	Drain overflow safeguard operation	F1 - FA	Unit nonconformity	FFFF	No relevant unit
P6	Freezing/overheating safeguard operation	E0 - E5	Signal error between remote controller and unit		

See the chart below for details of the LED displays (LED 1, 2, 3) on the indoor-side controller board.

LED 1 (microcomputer power supply)	Displays the ON/OFF of power for control. Check that this is lit during normal use.
LED 2 (remote controller feed)	Displays the ON/OFF of feed to wired remote controller. Is only lit for the unit of outdoor-side controller board with address "00".
LED 3 (indoor and outdoor signals)	Displays signal between indoor-side and outdoor-side controller boards. Check that this is flashing during normal use.

2) Unit

1) Check Items

- After installation of the unit, and electric wiring work, check that the unit is free from leaks of refrigerant, loosened connections, and incorrect polarity.
- Check that there is no negative phase and open phase. (The F1 message for negative phase and the F2 message for open phase will flash at LED 1 on the outdoor-side controller board. If this happens, rewire correctly.)
- Measure the impedance between power terminals (Single phase: L, N, ⊕/triple phase: L1, L2, L3, N, ⊕) and the ground with a 500 V Megger and check that it is 1.0 MΩ or more. Do not operate the equipment if measurement is less than 1.0 MΩ.
- When there is no error at the unit.
(If there is an error at the unit, it can be evaluated at LED 1 [digital display] of the outdoor-side controller board.)
- The stop valves are open both the liquid and gas sides.
After checking the above, execute the test run in accordance with the following.

2) Test run start and finish

- Operation from the indoor-side controller board
Execute the test run using the installation manual for the indoor-side controller board.
- Operation from the outdoor-side controller board
Execute settings for test run start, finish and operation mode (cooling, heating) using the DIP switch SW 4 on the outdoor-side controller board.

[Fig. 12.2.2] (P.6)

- Ⓐ Stop
- Ⓑ Cooling
- Ⓒ Operation
- Ⓓ Heating

- ① Set the operation mode (cooling, heating) using SW 4-2
- ② Turn ON SW 4-1, The operation mode for SW 4-2 will be adhered to, and the test run will commence
- ③ Turn OFF SW 4-1 to finish the test run

- There may be a faint knocking noise emitted from the proximity of the fan during the test run. This is torque fluctuation occurring due to control of fan revolutions. There is no problem with the product.

Note:

The SW 4-2 operation mode cannot be changed during the test run. (To change test run mode, stop the equipment with SW 4-1, change the operation mode, then restart test run with SW 4-1.)

- If the 2-hour timer is set, the test run will stop automatically after 2 hours.
- During the test run, the room temperature display shows the unit indoor-side liquid piping temperatures.

12.3. Self-diagnosis

Use the remote controller to look up each units error history.

[Fig. 12.3.1] (P.7)

① Change to self-diagnosis mode

Press the CHECK button twice within three seconds to show the following display.

② Select the refrigerant address number to be self-diagnosed

Press the buttons to scroll through the refrigerant address numbers (00 to 15) and select the refrigerant address number to be self-diagnosed. After three seconds from making the change, the lit refrigerant address to be self-diagnosed will start to flash, and self-diagnosis will commence.

③ Self-diagnosis result display

See the above chart for details of error code contents.

- (1) When there is an error history
- (2) When there is no error history
- (3) When the address does not exist
 - a) Alternating display
 - b) Error code
 - c) Attribute of error search
 - d) Unit number

④ Reset error history

Display the error history at the self-diagnosis result display screen ③.

The address for self-diagnosis will flash when the button is pressed twice within three seconds.

The diagram on the left will be displayed when error history has been reset. Note that the error content will be redisplayed if error history resetting is unsuccessful.

- a) Alternating display

⑤ Canceling self-diagnosis

The following two methods can be used to cancel self-diagnosis.

Press the CHECK button twice within three seconds to cancel self-diagnosis. The display screen will return to the status before self-diagnosis.

Press the ① ON/OFF button to cancel self-diagnosis. The unit will stop.

(This operation is ineffectual when operation is prohibited.)

12.4. Remote controller diagnosis

If operation cannot be carried out from the remote controller, use this function to diagnose the remote controller.

[Fig. 12.4.1] (P.7)

① First, check the electricity current marker

If the correct voltage (DC 12 V) is not displayed on the remote controller, the electric current marker will be lit.

If the electricity current marker is not lit, check the remote controller wiring and the units.

- ① Electric current marker

② Transfer to remote control mode

Hold down the CHECK button for five seconds or more to display the diagram on the left.

Press the FILTER button to commence diagnosis of remote controller.

③ Remote controller diagnosis results

- (1) The remote control is functioning correctly.
Check other possible causes as there are no problems with the remote controller.
- (2) The remote controller has a nonconformity.
The remote controller must be replaced.
Error display 1 ("NG") flashes to show a nonconformity in the transmitter-receiver circuit.

Potential problems other than those diagnosed for the remote controller.

- (1) Single transmission not possible if error display 2 ("E3") flashes.
There is "noise" on the transmission line, or damage of other remote controllers for the units can be considered. Check the transmission path and other controllers.
- (2) Data error has occurred when error display three shows "ERC" and number of data errors.
Number of generated data errors (maximum 66 errors).
The number of generated data errors stands for the difference in the number of bits of transmitted data from the remote controller and the actual number of bits that were transmitted along the transmission path. If this error occurs, "noise", etc., is interfering with the transmission data. Check the transmission path.
 - ⊗ When the number of data errors generated is 02
 - Ⓛ Remote controller transmission data
 - Ⓜ Transmission data at transmission path
- ④ **Cancel the remote controller diagnosis**
Hold down the CHECK button for five seconds or more to cancel the remote controller diagnosis. The "H0" operation lamp will flash, and the display screen will return to the status before remote controller diagnosis in approximately 30 seconds.



13. Troubleshooting

13.1. How to handle problems with the test run

Error code list: details

Error details	Problem location	MELANS display	Remote controller display
Remote controller communication – reception error	Remote Controller	6831,6834	E0
Remote controller communication – transmission error	Remote Controller	6832,6833	E3
Remote controller communication – reception error	Indoor-side controller board	6831,6834	E4
Remote controller communication – transmission error	Indoor-side controller board	6832,6833	E5
Communication between indoor-side and outdoor-side controller boards – reception error	Indoor-side controller board	6740,6843	E6
Communication between indoor-side and outdoor-side controller boards – transmission error	Indoor-side controller board	6841,6842	E7
Communication between indoor-side and outdoor-side controller boards – reception error	Outdoor-side controller board	6840,6843	E8
Communication between indoor-side and outdoor-side controller boards – transmission error	Outdoor-side controller board	6841,6842	E9
Connection wiring error (interference, loose)	Outdoor-side controller board	6844	EA
Connection wiring error (interference, loose)	Outdoor-side controller board	6845	EB
Excessive time in use	Outdoor-side controller board	6846	EC
Serial communication error	Outdoor-side controller board	0403	ED
Serial communication error	M-NET board	0403	EE
Reverse phase, out of phase verification	Outdoor-side controller board	4103	F1
Faulty input circuit	Outdoor-side controller board	4115	F8
Duplicated M-NET address setting	M-NET board	6600	A0
M-NET error in PH/W transmission	M-NET board	6602	A2
M-NET bus busy	M-NET board	6603	A3
M-NET communication error with P transmission	M-NET board	6606	A6
M-NET error – no ACK	M-NET board	6607	A7
M-NET error – no response	M-NET board	6608	A8
Undefined error code	–	undefined	EF
Discharge temperature error	Outdoor-side controller board	1102	U2
CN23 Short-circuit Connector Unplugged	Outdoor-side controller board	1108	U2
Open/short in discharge temp thermistor	Outdoor-side controller board	5104	U3
Open/short in liquid temp or condenser/evaporator temp thermistor	Outdoor-side controller board	5105	U4
Compressor overcurrent interruption (51C operation)	Outdoor-side controller board	4101	U6
High pressure error (63H1 operation)	Outdoor-side controller board	1302	UE
Low pressure error (63L operation)	Outdoor-side controller board	1300	UL
Power synchronous idle circuit error	Outdoor-side controller board	4115	F8
Inlet sensor error	Indoor-side controller board	5101	P1
Piping (liquid pipe) sensor error	Indoor-side controller board	5102	P2
Drain sensor error	Indoor-side controller board	2503	P4
Drain overflow protector operation	Indoor-side controller board	2502	P5
Water leak error	Indoor-side controller board	2500	P5
Freeze prevention operation	Indoor-side controller board	1503	P6
Surge prevention operation	Indoor-side controller board	1504	P6
Piping temperature error	Indoor-side controller board	1110	P8
Piping (2-phase pipe) sensor error	Indoor-side controller board	5103	P9

- Depending on the position of the SW2 switch on the outdoor unit board, the segments light up to indicate the running condition of the unit and the particulars of the check code.

SW2 setting 123456	Item	Display contents																														
000000	Operation mode/relay output	tens place units place	O: stop C: cooling H: heating d: defrosting 1: SV1 2: 21S4 4: 52C Relay output = SV1 + 21S4 + 52C Ex. During cooling mode, when 52C and SV1 are ON: C5 When an error occurs, the error code and error signal (*1) are displayed in alternation.																													
011110	Outdoor unit control condition	Control mode display system																														
010110	Indoor-side control condition (IC1)	 Nothing  Indoor-side Outdoor-side	<table border="1"> <thead> <tr> <th rowspan="2">Display</th> <th colspan="2">Control mode</th> </tr> <tr> <th>Indoor-side</th> <th>Outdoor-side</th> </tr> </thead> <tbody> <tr><td>0</td><td>Ordinary</td><td>←</td></tr> <tr><td>1</td><td>Hot adjustment</td><td>←</td></tr> <tr><td>2</td><td>Defrosting</td><td>←</td></tr> <tr><td>3</td><td>—</td><td>←</td></tr> <tr><td>4</td><td>Heater ON</td><td>←</td></tr> <tr><td>5</td><td>Freeze prevention</td><td>←</td></tr> <tr><td>6</td><td>Surge prevention</td><td>←</td></tr> <tr><td>7</td><td>Compressor OFF</td><td>←</td></tr> </tbody> </table>	Display	Control mode		Indoor-side	Outdoor-side	0	Ordinary	←	1	Hot adjustment	←	2	Defrosting	←	3	—	←	4	Heater ON	←	5	Freeze prevention	←	6	Surge prevention	←	7	Compressor OFF	←
Display	Control mode																															
	Indoor-side	Outdoor-side																														
0	Ordinary	←																														
1	Hot adjustment	←																														
2	Defrosting	←																														
3	—	←																														
4	Heater ON	←																														
5	Freeze prevention	←																														
6	Surge prevention	←																														
7	Compressor OFF	←																														
011100	Error code history 1	The error code (ex. U8, UA) and error indicator (*1) are displayed in alternation.																														
111100	Error code history 2																															

*1 Display system for error indicator

The indicator corresponds to the following numbers

- 0 Outdoor unit
- 1 Indoor unit

13.2. The following occurrences are not problems or errors

Problem	Remote controller display	Cause
The fan setting changes during heating.	Ordinary display	During thermostat OFF mode, light air or low air operation will take place. During thermostat ON mode, light air or low air will switch automatically to set notch on the basis of time or piping temperature.
The fan stops during heating.	Defrosting display	During defrosting, the fan will stop.
When the switch is turned ON, the fan does not begin to operate.	Heating preparations underway	After the switch is turned to ON or until the piping temperature reaches 35°C, there will be 5 minutes of light air operation. After that there will be 2 minutes of low air operation, then set notch will begin (hot adjustment control).
The outdoor-side fan turns in reverse or stops, and an unusual sound is heard.	Ordinary display	There is a risk of the power to the unit being connected in reverse phase. Be sure to check that the phase is correct.

Note:

If indoor-side fan does not operate, check the over-current relay on the fan motor to determine whether it has been tripped.

If the over-current relay has been tripped, reset it after eliminating the cause of the problem (e.g. motor lock).

To reset the over-current relay, open the control box and press the green claw on bottom-right of the relay until a click is heard. Release the claw and check that it returns to its original position.

Note that if it is pressed too hard it will not return to its original position.

14. System control

14.1. System settings

[Fig. 14.1.1] (P.7)

- Ⓐ Unit
- Ⓑ Master remote controller
- Ⓒ Subordinate remote controller
- Ⓓ Refrigerant address = 00

* Set the refrigerant address using the DIP switch of the outdoor-side controller board.

① Wiring from the Remote Control

This wire is connected to TB5 (terminal board for remote controller) of the unit (non-polar).

② When a Different Refrigerant System Grouping is Used

Up to 16 refrigerant systems can be controlled as one group using the slim MA remote controller.

Note:

In single refrigerant system, there is no need of wiring ②.

SW1
Function table

<SW1>



	Function	Operation according to switch setting	
		ON	OFF
SW1 function settings	1 Compulsory defrosting	Start	Normal
	2 Error history clear	Clear	Normal
	3 Refrigerant system address setting	Settings for outdoor unit addresses 0 to 15	
	4		
	5		
	6		

14.2. Examples of refrigerant system address setting

Ex.	Unit	Unit	Unit refrigerant system address	Remote controller power supply unit
1	PRH-P8-10MYA	—	00	○

* Set the refrigerant system address of one unit to 00 for the power supply to the remote controller.

(The refrigerant system address is set to 00 when shipped from the factory.)

Do not duplicate the refrigerant system address settings within the same system.

This product is designed and intended for use in the residential, commercial and light-industrial environment.

The product at hand is based on the following EU regulations:

- Low Voltage Directive 73/23/EEC
- Electromagnetic Compatibility Directive 89/336/EEC

Please be sure to put the contact address/telephone number on this manual before handing it to the customer.