

# SERVICE MANUAL

## Series PLA Ceiling Cassettes

**R407C/R410A**
**Indoor unit  
[Model names]**

 PLA-RP35AA  
 PLA-RP50AA  
 PLA-RP60AA  
 PLA-RP71AA  
 PLA-RP100AA  
 PLA-RP125AA  
 PLA-RP140AA

**[Service Ref.]**

 PLA-RP35AA.UK  
 PLA-RP50AA.UK  
 PLA-RP60AA.UK  
 PLA-RP71AA.UK  
 PLA-RP100AA.UK  
 PLA-RP125AA.UK  
 PLA-RP140AA.UK

**Revision:**

- RoHS PARTS LIST is added.
- Some descriptions have been modified.

- Please void OC335.

**Note:**

- This manual describes only service data of the indoor units.
- RoHS compliant products have <G> mark on the spec name plate.
- For servicing of RoHS compliant products, refer to the RoHS Parts List.

## Series PLH

**R407C**

 PLH-P35AAH  
 PLH-P50AAH  
 PLH-P60AAH  
 PLH-P71AAH  
 PLH-P100AAH  
 PLH-P125AAH  
 PLH-P140AAH

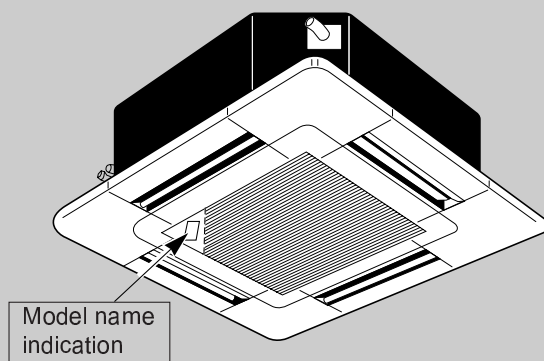
 PLH-P35AAH.UK  
 PLH-P50AAH.UK  
 PLH-P60AAH.UK  
 PLH-P71AAH.UK  
 PLH-P100AAH.UK  
 PLH-P125AAH.UK  
 PLH-P140AAH.UK

INDOOR UNIT

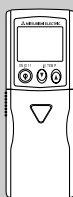
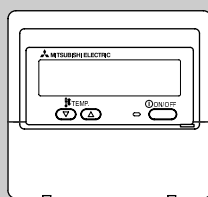
 WIRELESS REMOTE  
CONTROLLER

 WIRED REMOTE  
CONTROLLER

## CONTENTS

1. REFERENCE MANUAL .....	2
2. SAFETY PRECAUTION .....	2
3. PART NAMES AND FUNCTIONS .....	6
4. SPECIFICATIONS .....	9
5. NOISE CRITERION CURVES .....	14
6. OUTLINES AND DIMENSIONS .....	16
7. WIRING DIAGRAM .....	17
8. REFRIGERANT SYSTEM DIAGRAM .....	18
9. TROUBLESHOOTING .....	19
10. DISASSEMBLY PROCEDURE .....	35
11. PARTS LIST .....	38
12. RoHS PARTS LIST .....	45

# 11

## PARTS LIST (non-RoHS compliant)

### PANEL PARTS

PLA-RP35AA.UK    PLH-P35AAH.UK  
 PLA-RP50AA.UK    PLH-P50AAH.UK  
 PLA-RP60AA.UK    PLH-P60AAH.UK  
 PLA-RP71AA.UK    PLH-P71AAH.UK  
 PLA-RP100AA.UK    PLH-P100AAH.UK  
 PLA-RP125AA.UK    PLH-P125AAH.UK  
 PLA-RP140AA.UK    PLH-P140AAH.UK

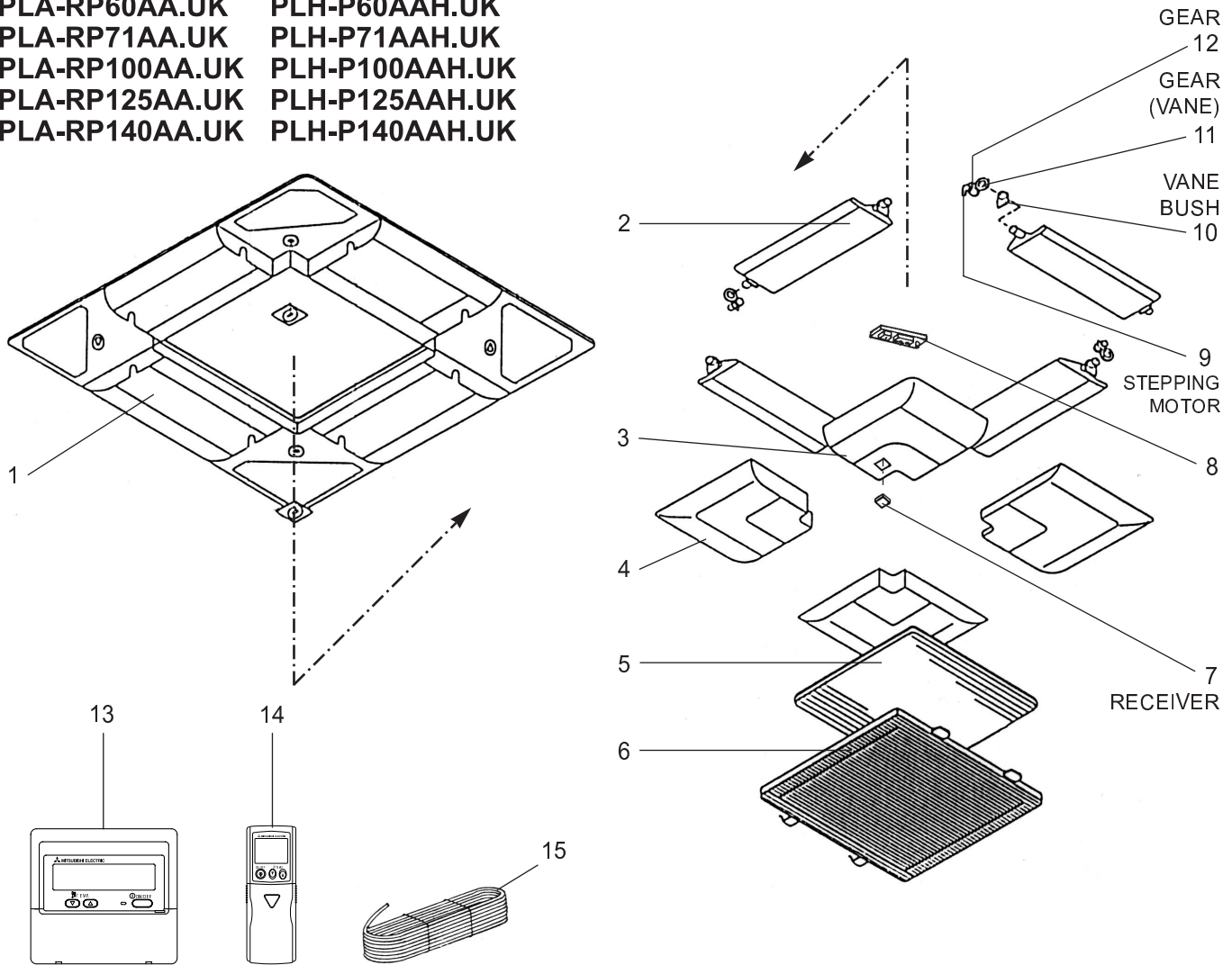

No.	Parts No.	Parts Name	Specifi- cation	Q'ty / set		Remarks (Drawing No.)	Wiring Diagram Symbol	Recom- mended Q'ty	Price	
				PLA-RP35,50,60,71,100,125,140AA.UK PLH-P35,50,60,71,100,125,140AAH.UK	WIRED				WIRELESS	Unit
1	S70 E10 003	AIR OUTLET GRILLE		1	1					
2	S70 E01 002	VANE ASSY		4	4					
3	S70 E01 638	CORNER PANEL		1	2					
4	S70 E00 638	CORNER PANEL		3	2					
5	S70 E00 500	L.L FILTER-A		1	1					
6	S70 E00 691	GRILLE ASSY		1	1					
7	S70 24K 658	RECEIVER			1		RU			
8	S70 E00 317	WIRELESS ADAPTER			1		W.B			
9	S70 E00 223	STEPPING MOTOR		4	4		MV			
10	S70 E00 063	VANE BUSH		8	8					
11	S70 E00 040	GEAR (VANE)		4	4					
12	S70 E01 040	GEAR		4	4					
13	S70 KW1 713	REMOTE CONTROLLER ASSY	PAR-21MAA-E	1			R.B			
14	S70 E15 714	WIRELESS REMOTE CONTROLLER ASSY	PAR-SL97A-E		1					
15	S70 58A 246	CORD		1						

## FUNCTIONAL PARTS

PLA-RP35AA.UK  
 PLA-RP50AA.UK  
 PLA-RP60AA.UK  
 PLA-RP71AA.UK

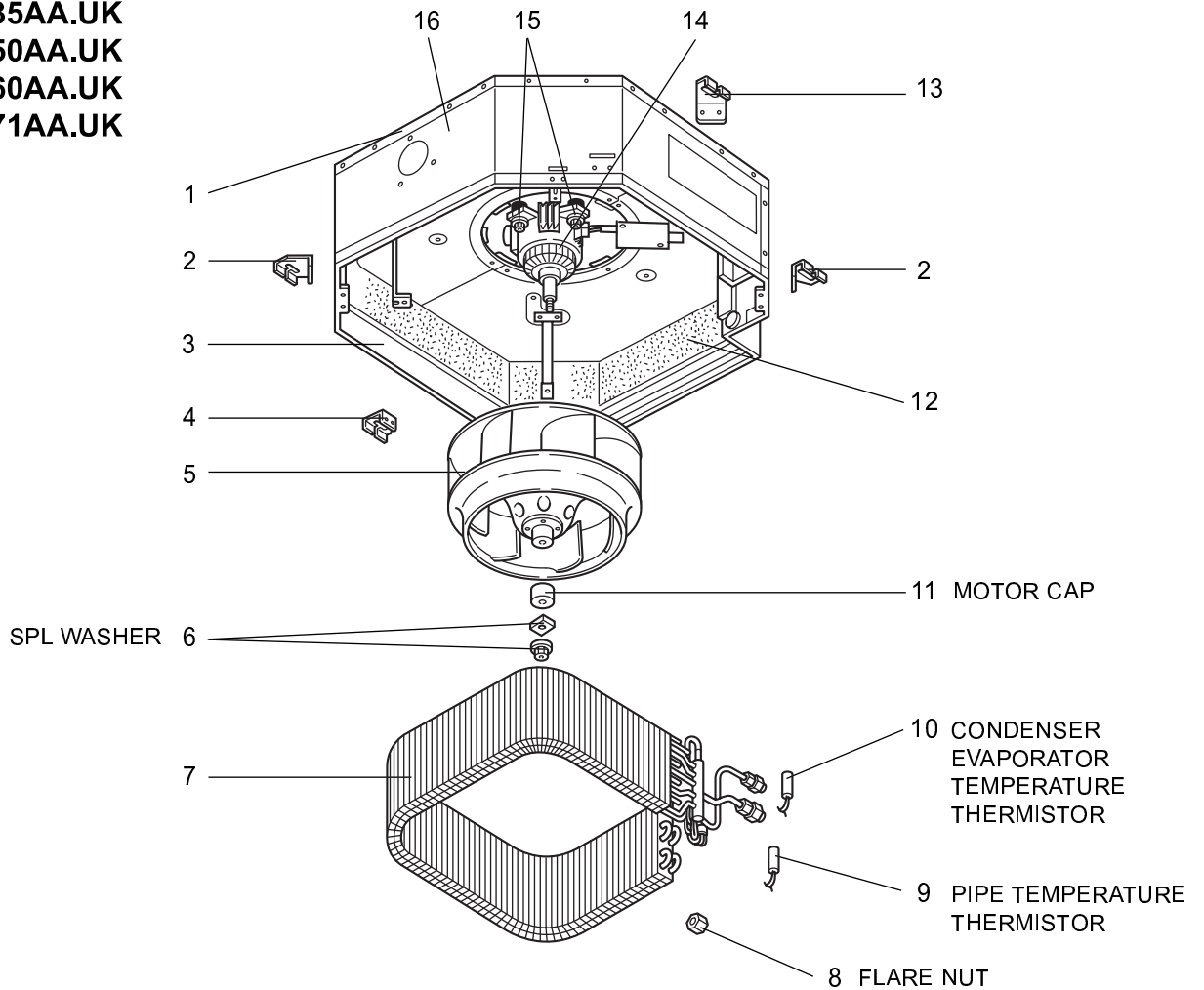

No.	Parts No.	Parts Name	Specifi- cation	Q'ty / set			Remarks (Drawing No.)	Wiring Diagram Symbol	Recom- mended Q'ty	Price	
				PLA-RP-AA.UK						Unit	Amount
				35,50	60	71					
1	S70 003 687	BASE		1	1	1					
2	S70 E01 130	LEG		2	2	2					
3	S70 005 688	DRUM 1 ASSY		1	1	1					
4	S70 E00 130	LEG		1	1	1					
5	S70 E00 114	TURBO FAN		1	1	1					
6	S70 08K 097	SPL WASHER / NUT		1	1	1					
7	S70 K16 480	HEAT EXCHANGER		1							
	S70 E17 480	HEAT EXCHANGER			1						
	S70 E40 480	HEAT EXCHANGER				1					
8	S70 E15 097	FLARE NUT	5/8"	1	1	1					
9	S70 17J 202	PIPE TEMPERATURE THERMISTOR		1	1	1		TH2			
10	S70 E20 202	CONDENSER EVAPORATOR TEMPERATURE THERMISTOR		1	1	1		TH5			
11	S70 E50 129	MOTOR CAP		1	1						
12	S70 E00 659	INNER COVER		1	1	1					
13	S70 E02 130	LEG		1	1	1					
14	S70 E06 762	FAN MOTOR	D17B6P70MS	1	1	1		MF			
15	S70 A41 105	MOTOR MOUNT		4	4	4					
16	S70 006 688	DRUM 2 ASSY		1	1	1					

## FUNCTIONAL PARTS

PLA-RP100AA.UK

PLA-RP125AA.UK

PLA-RP140AA.UK

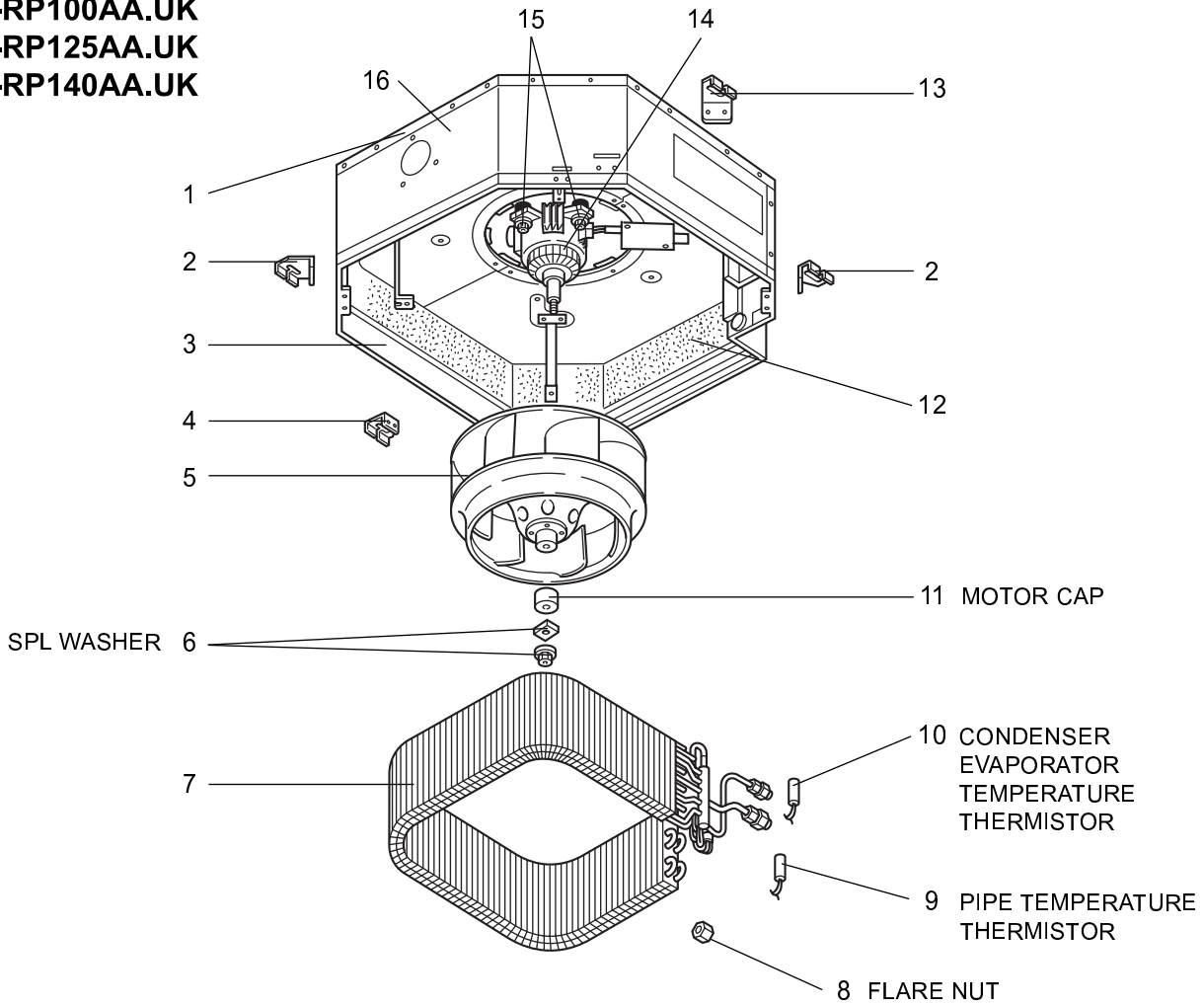

No.	Parts No.	Parts Name	Specifi- cation	Q'ty / set		Remarks (Drawing No.)	Wiring Diagram Symbol	Recom- mended Q'ty	Price	
				PLA-RP.AA.UK					Unit	Amount
				100	125,140					
1	S70 003 687	BASE		1	1					
2	S70 E01 130	LEG		2	2					
3	S70 007 688	DRUM 1 ASSY		1	1					
4	S70 E00 130	LEG		1	1					
5	S70 E01 114	TURBO FAN		1	1					
6	S70 08K 097	SPL WASHER		1	1					
7	S70 K18 480	HEAT EXCHANGER		1	1					
	S70 K19 480	HEAT EXCHANGER								
8	S70 E16 097	FLARE NUT	3/4"	1	1					
9	S70 17J 202	PIPE TEMPERATURE THERMISTOR		1	1		TH2			
10	S70 E20 202	CONDENSER EVAPORATOR TEMPERATURE THERMISTOR		1	1		TH5			
11	S70 E50 129	MOTOR CAP		1	1					
12	S70 E02 659	INNER COVER		1	1					
13	S70 E02 130	LEG		1	1					
14	S70 E07 762	FAN MOTOR	D176P120MS	1	1		MF			
15	S70 A41 105	MOTOR MOUNT		4	4					
16	S70 008 688	DRUM 2 ASSY		1	1					

**FUNCTIONAL PARTS**

PLH-P35AAH.UK  
 PLH-P50AAH.UK  
 PLH-P60AAH.UK  
 PLH-P71AAH.UK

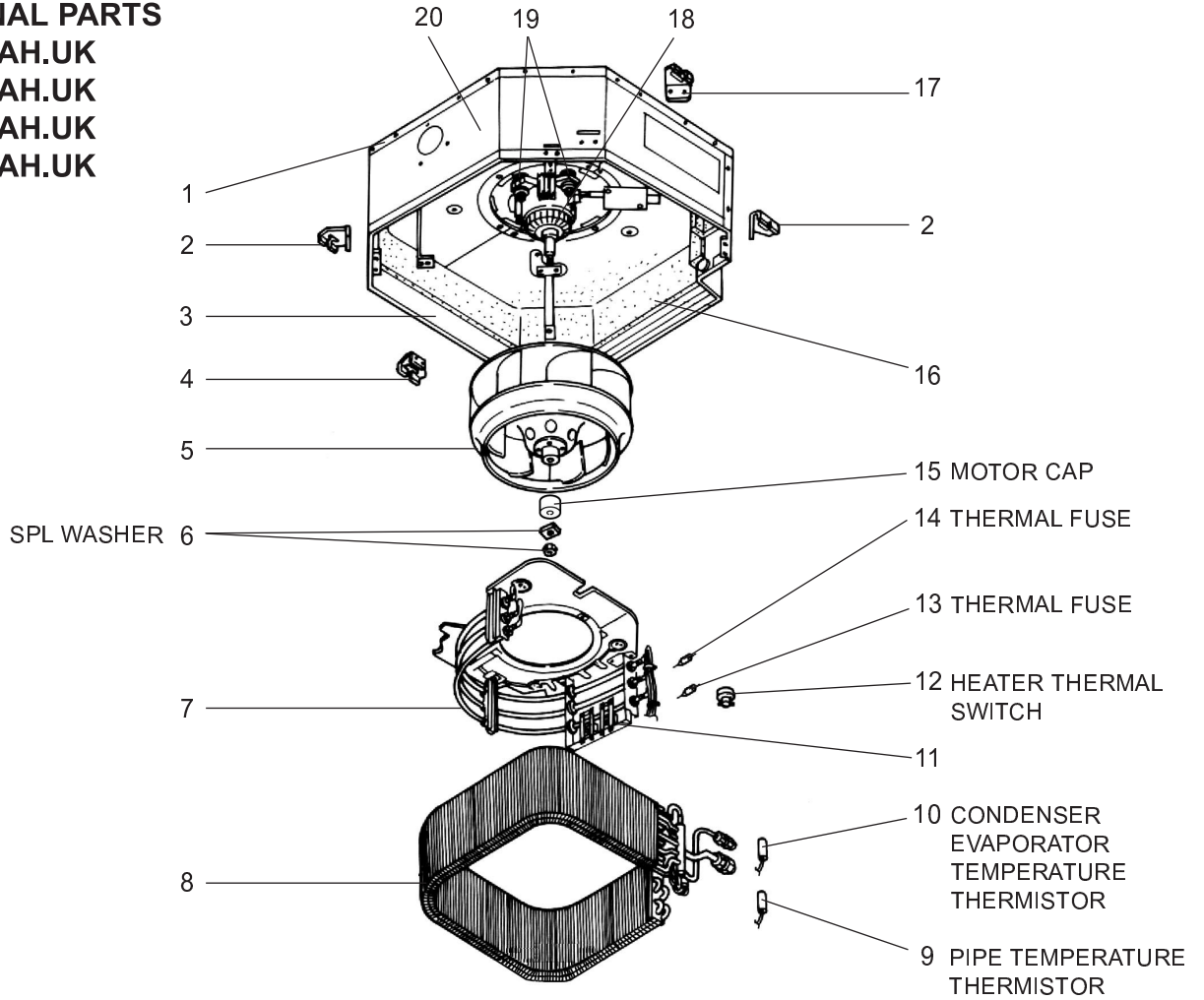

No.	Parts No.	Parts Name	Specification	Q'ty / set			Remarks (Drawing No.)	Wiring Diagram Symbol	Recom- mended Q'ty	Price	
				PLH -P-AAH.UK						Unit	Amount
				35,50	60	71					
1	S70 003 687	BASE		1	1	1					
2	S70 E01 130	LEG		2	2	2					
3	S70 005 688	DRUM 1 ASSY		1	1	1					
4	S70 E00 130	LEG		1	1	1					
5	S70 E00 114	TURBO FAN		1	1	1					
6	S70 08K 097	SPL WASHER		1	1	1					
7	S70 E08 300	HEATER ELEMENT	240V/467W	3	3	3	H1				
	S70 E07 300	HEATER ELEMENT	240V/700W								
8	S70 E20 480	HEAT EXCHANGER		1	1	1					
9	S70 17J 202	PIPE TEMPERATURE THERMISTOR		1	1	1	TH2				
10	S70 E20 202	CONDENSER EVAPORATOR TEMPERATURE THERMISTOR		1	1	1	TH5				
11	S70 20J 303	INSULATOR		1	1	1					
12	S70 46K 700	HEATER THERMAL SWITCH	50°C OFF	1	1	1	26H				
13	S70 E02 706	THERMAL FUSE	104°C, 16A	1	1	1	FS2				
14	S70 E03 706	THERMAL FUSE	72°C, 16A	1	1	1	FS1				
15	S70 E50 129	MOTOR CAP		1	1						
16	S70 E01 659	INNER COVER		1	1	1					
17	S70 E02 130	LEG		1	1	1					
18	S70 E06 762	FAN MOTOR	D17B6P70MS	1	1	1	MF				
19	S70 A41 105	MOTOR MOUNT		4	4	4					
20	S70 006 688	DRUM 2 ASSY		1	1	1					

**FUNCTIONAL PARTS**  
**PLH-P100AAH.UK**  
**PLH-P125AAH.UK**  
**PLH-P140AAH.UK**

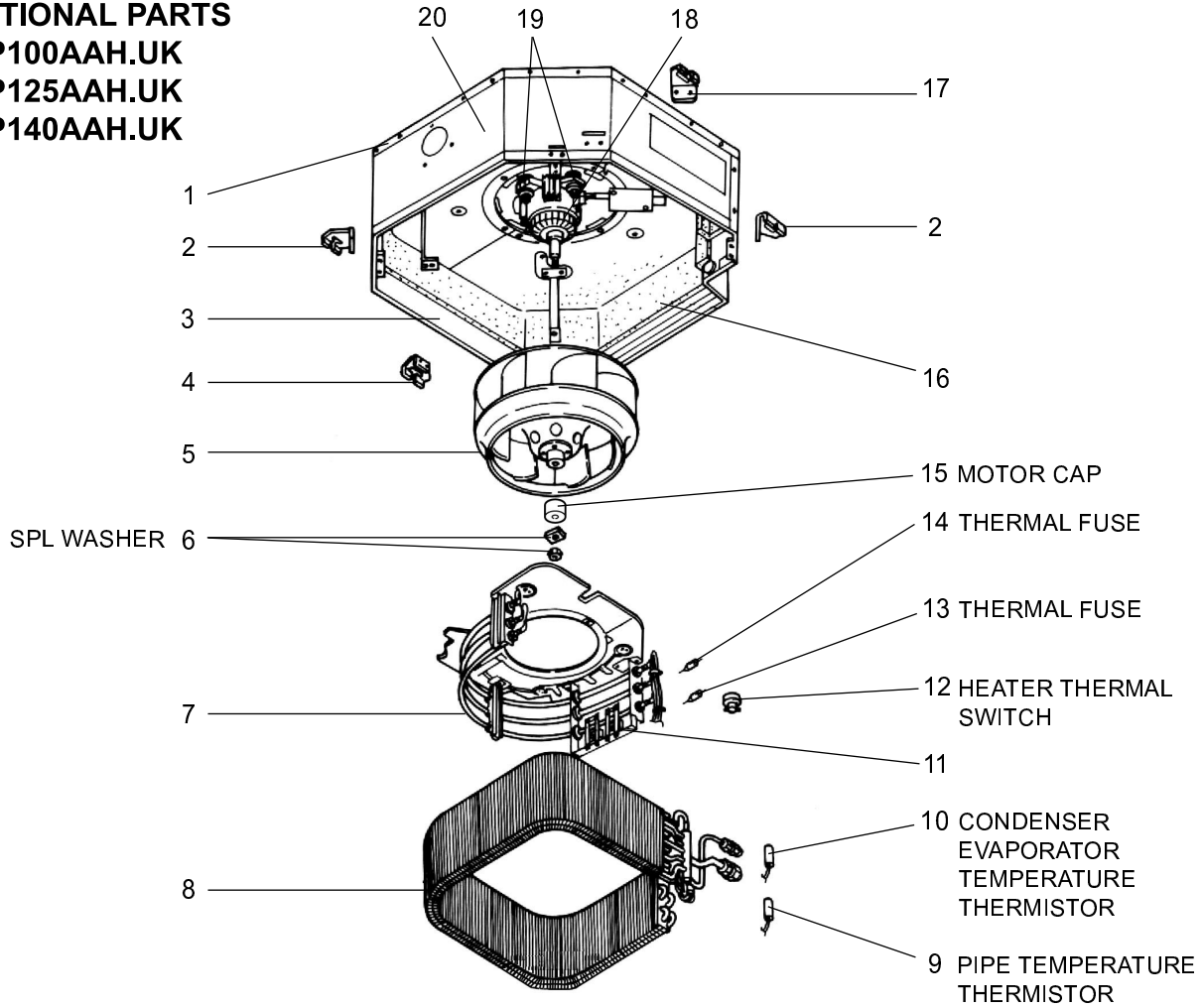

No.	Parts No.	Parts Name	Specification	Q'ty / set		Remarks (Drawing No.)	Wiring Diagram Symbol	Recom- mended Q'ty	Price	
				PLH -P100	PLH -P125,140				Unit	Amount
				AAH.UK	AAH.UK					
1	S70 003 687	BASE		1	1					
2	S70 E01 130	LEG		2	2					
3	S70 007 688	DRUM 1 ASSY		1	1					
4	S70 E00 130	LEG		1	1					
5	S70 E01 114	TURBO FAN		1	1					
6	S70 08K 097	SPL WASHER		1	1					
7	S70 E06 300	HEATER ELEMENT	240V/867W	3	3		H1			
	S70 E05 300	HEATER ELEMENT	240V/1000W				H1			
8	S70 E21 480	HEAT EXCHANGER		1	1					
	S70 E25 480	HEAT EXCHANGER								
9	S70 17J 202	PIPE TEMPERATURE THERMISTOR		1	1		TH2			
10	S70 E20 202	CONDENSER/EVAPORATOR TEMPERATURE THERMISTOR		1	1		TH5			
11	S70 20J 303	INSULATOR		1	1					
12	S70 46K 700	HEATER THERMAL SWITCH	50°C OFF	1	1		26H			
13	S70 E02 706	THERMAL FUSE	104°C, 16A	1	1		FS2			
14	S70 E04 706	THERMAL FUSE	72°C, 16A	1	1		FS1			
15	S70 E50 129	MOTOR CAP		1	1					
16	S70 E04 659	INNER COVER		1	1					
17	S70 E02 130	LEG		1	1					
18	S70 E07 762	FAN MOTOR	D176P120MS	1	1		MF			
19	S70 A41 105	MOTOR MOUNT		4	4					
20	S70 008 688	DRUM 2 ASSY		1	1					

## FUNCTIONAL PARTS

PLA-RP35AA.UK    PLA-RP100AA.UK  
 PLA-RP50AA.UK    PLA-RP125AA.UK  
 PLA-RP60AA.UK    PLA-RP140AA.UK  
 PLA-RP71AA.UK

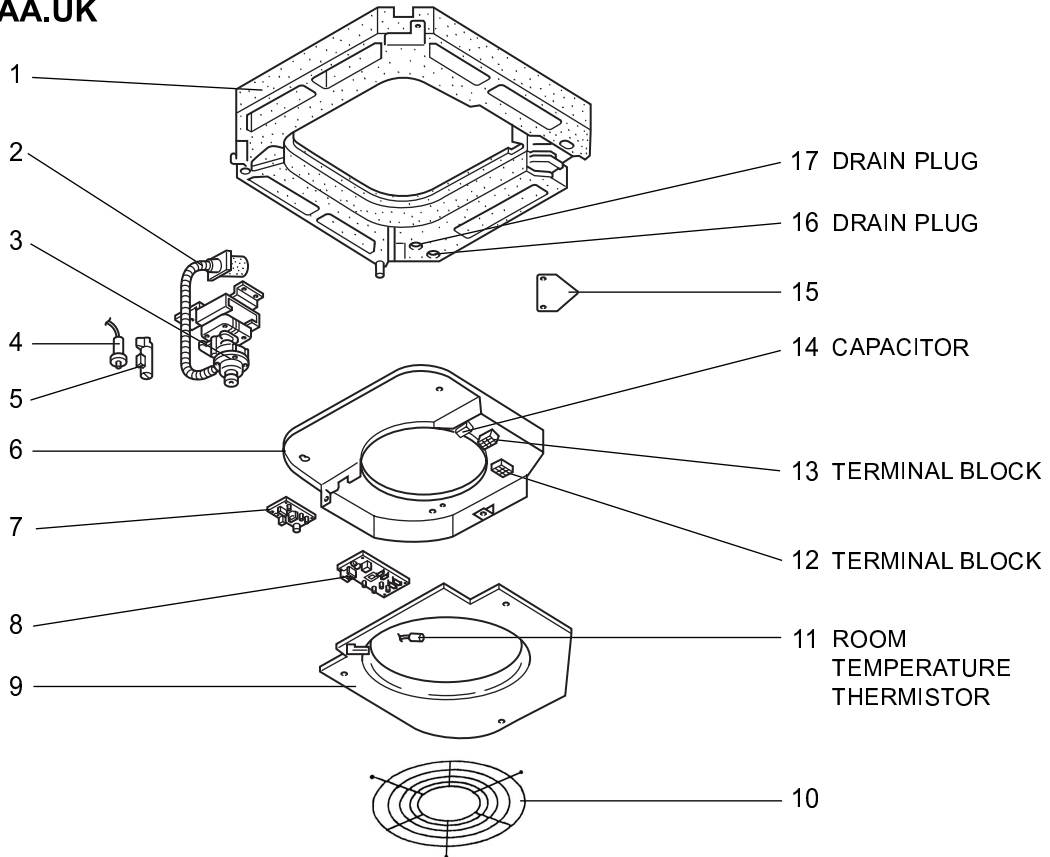

Part number that is circled is not shown in the figure.

No.	Parts No.	Parts Name	Specification	Q'ty / set				Remarks (Drawing No.)	Wiring Diagram Symbol	Recom- mended Q'ty	Price	
				PLA-RP · AA.UK							Unit	Amount
				35,50,60	71	100	125,140					
1	S70 E02 529	DRAIN PAN		1	1							
	S70 E00 529	DRAIN PAN				1						
	S70 E01 529	DRAIN PAN					1					
2	S70 29H 523	DRAIN SOCKET		1	1	1	1					
3	S70 E02 355	DRAIN PUMP		1	1	1	1		DP			
4	S70 E00 266	DRAIN SENSOR		1	1	1	1		DS			
5	S70 31K 241	DRAIN SENSOR HOLDER		1	1	1	1					
6	S70 E30 501	ELECTRICAL CONTROL BOX		1	1	1	1					
7	S70 K06 313	POWER BOARD		1	1	1	1		P.B			
8	S70 K80 310	INDOOR CONTROLLER BOARD		1	1	1	1		I.B			
9	S70 003 503	CONTROL COVER ASSY		1	1	1	1					
10	S70 E10 675	FAN GUARD		1	1	1	1					
11	S70 E00 202	ROOM TEMPERATURE THERMISTOR		1	1	1	1		TH1			
12	S70 512 716	TERMINAL BLOCK	2P (1, 2)	1	1	1	1		TB5			
13	S70 E01 716	TERMINAL BLOCK	3P (S1, S2, S3)	1	1	1	1		TB4			
14	S70 576 255	CAPACITOR	3 $\mu$ F 440V	1					C			
	S70 17T 255	CAPACITOR	3.5 $\mu$ F 440V		1				C			
	S70 E02 255	CAPACITOR	7 $\mu$ F 440V			1	1		C			
15	S70 001 663	CORNER COVER		1	1	1	1					
16	S70 A48 524	DRAIN PLUG		1	1	1	1					
17	S70 A41 524	DRAIN PLUG		1	1	1	1					
18	S70 A41 523	DRAIN HOSE ASSY		1	1	1	1					

## FUNCTIONAL PARTS

PLH-P35AAH.UK PLH-P100AAH.UK  
 PLH-P50AAH.UK PLH-P125AAH.UK  
 PLH-P60AAH.UK PLH-P140AAH.UK  
 PLH-P71AAH.UK

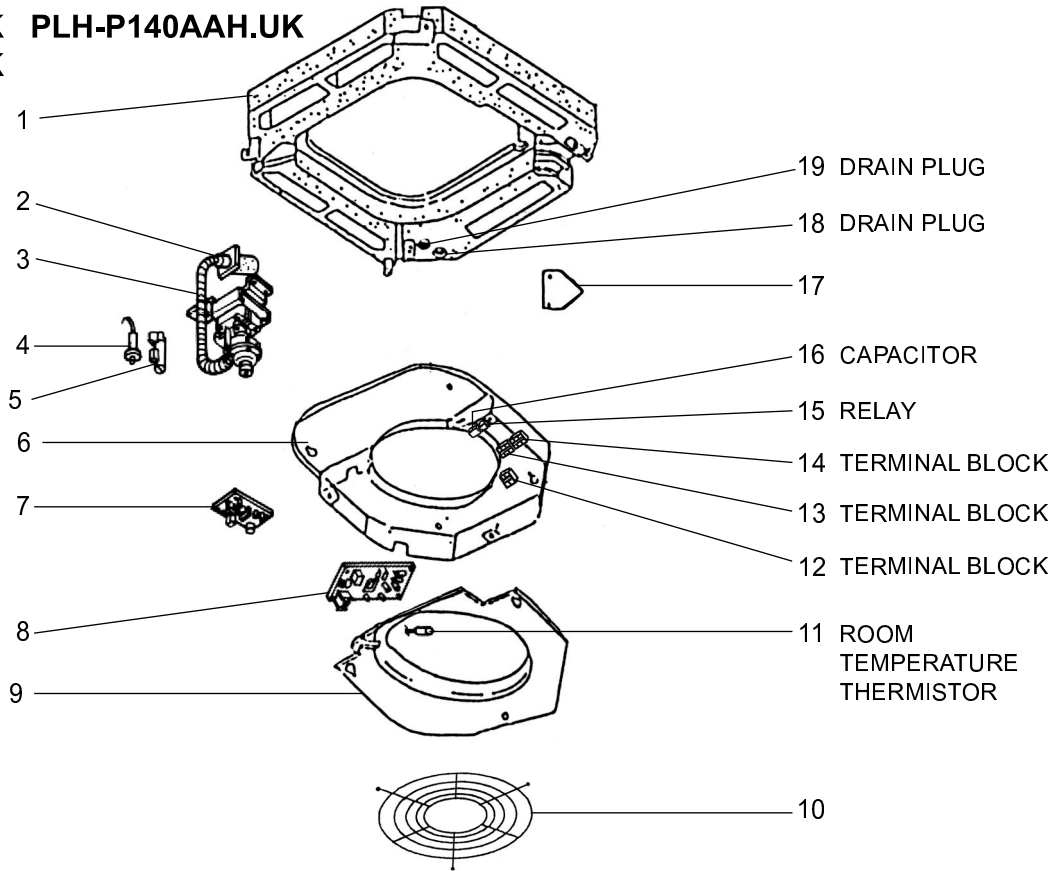

Part number that is circled is not shown in the figure.

No.	Parts No.	Parts Name	Specification	Q'ty / set				Remarks (Drawing No.)	Wiring Diagram Symbol	Recom- mended Q'ty	Price	
				PLH -P • AAH.UK							Unit	Amount
				35,50,60	71	100	125,140					
1	S70 E02 529	DRAIN PAN		1	1							
	S70 E00 529	DRAIN PAN				1						
	S70 E01 529	DRAIN PAN					1					
2	S70 29H 523	DRAIN SOCKET		1	1	1	1					
3	S70 E02 355	DRAIN PUMP		1	1	1	1		DP			
4	S70 E00 266	DRAIN SENSOR		1	1	1	1		DS			
5	S70 31K 241	DRAIN SENSOR HOLDER		1	1	1	1					
6	S70 E30 501	ELECTRICAL CONTROL BOX		1	1	1	1					
7	S70 K06 313	POWER BOARD		1	1	1	1		P.B			
8	S70 K80 310	INDOOR CONTROLLER BOARD		1	1	1	1		I.B			
9	S70 003 503	CONTROL COVER ASSY		1	1	1	1					
10	S70 E10 675	FAN GUARD		1	1	1	1					
11	S70 E00 202	ROOM TEMPERATURE THERMISTOR		1	1	1	1		TH1			
12	S70 512 716	TERMINAL BLOCK	2P (1, 2)	1	1	1	1		TB5			
13	S70 E01 716	TERMINAL BLOCK	3P (S1, S2, S3)	1	1	1	1		TB4			
14	S70 521 716	TERMINAL BLOCK	3P (L, N, ⊕)	1	1	1	1		TB2			
15	S70 71G 215	RELAY	JC-1A DC12V	1	1	1	1		88H			
16	S70 576 255	CAPACITOR	3μF 440V	1					C			
	S70 17T 255	CAPACITOR	3.5μF 440V		1				C			
	S70 E02 255	CAPACITOR	7.0μF 440V			1	1		C			
17	S70 001 663	CORNER COVER		1	1	1	1					
18	S70 A41 524	DRAIN PLUG		1	1	1	1					
19	S70 A48 524	DRAIN PLUG		1	1	1	1					
20	S70 A41 523	DRAIN HOSE ASSY		1	1	1	1					



PANEL PARTS

- PLA-RP35AA.UK      PLH-P35AAH.UK
- PLA-RP50AA.UK      PLH-P50AAH.UK
- PLA-RP60AA.UK      PLH-P60AAH.UK
- PLA-RP71AA.UK      PLH-P71AAH.UK
- PLA-RP100AA.UK      PLH-P100AAH.UK
- PLA-RP125AA.UK      PLH-P125AAH.UK
- PLA-RP140AA.UK      PLH-P140AAH.UK

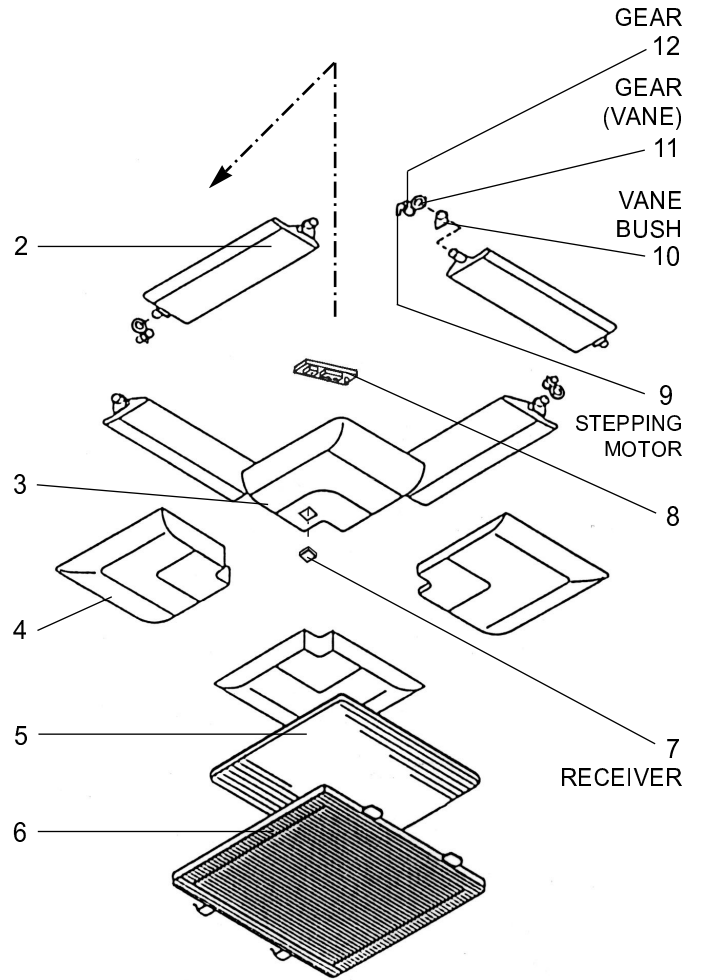
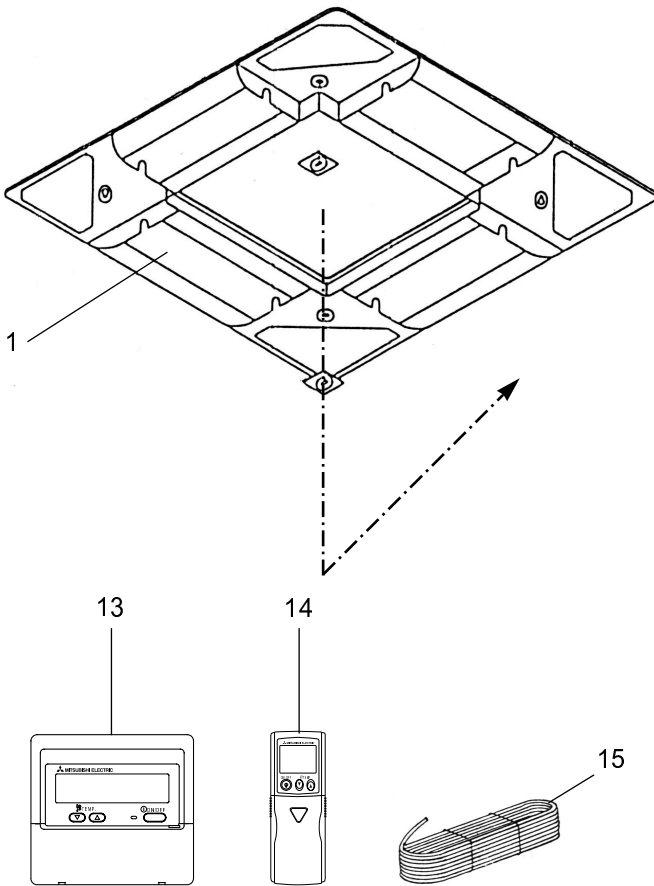

No.	RoHS	Parts No.	Parts Name	Specifi- cation	Q'ty / set		Remarks (Drawing No.)	Wiring Diagram Symbol	Recom- mended Q'ty	Price	
					PLA-RP35,50,60,71,100,125,140AA.UK PLH-P35,50,60,71,100,125,140AAH.UK	WIRED				WIRELESS	Unit
1	G	S70 E10 003	AIR OUTLET GRILLE		1	1					
2	G	S70 E01 002	VANE ASSY		4	4					
3	G	S70 E01 638	CORNER PANEL		1	2					
4	G	S70 E00 638	CORNER PANEL		3	2					
5	G	S70 E00 500	L.L FILTER-A		1	1					
6	G	S70 E00 691	GRILLE ASSY		1	1					
7	G	S70 24K 658	RECEIVER			1		RU			
8	G	S70 E00 317	WIRELESS ADAPTER			1		W.B			
9	G	S70 E00 223	STEPPING MOTOR		4	4		MV			
10	G	S70 E00 063	VANE BUSH		8	8					
11	G	S70 E00 040	GEAR (VANE)		4	4					
12	G	S70 E01 040	GEAR		4	4					
13	G	S70 KW1 713	REMOTE CONTROLLER ASSY	PAR-21MAA-E	1			R.B			
14	G	S70 E15 714	WIRELESS REMOTE CONTROLLER ASSY	PAR-SL97A-E		1					
15	G	S70 58A 246	CORD		1						

## FUNCTIONAL PARTS

PLA-RP35AA.UK  
 PLA-RP50AA.UK  
 PLA-RP60AA.UK  
 PLA-RP71AA.UK

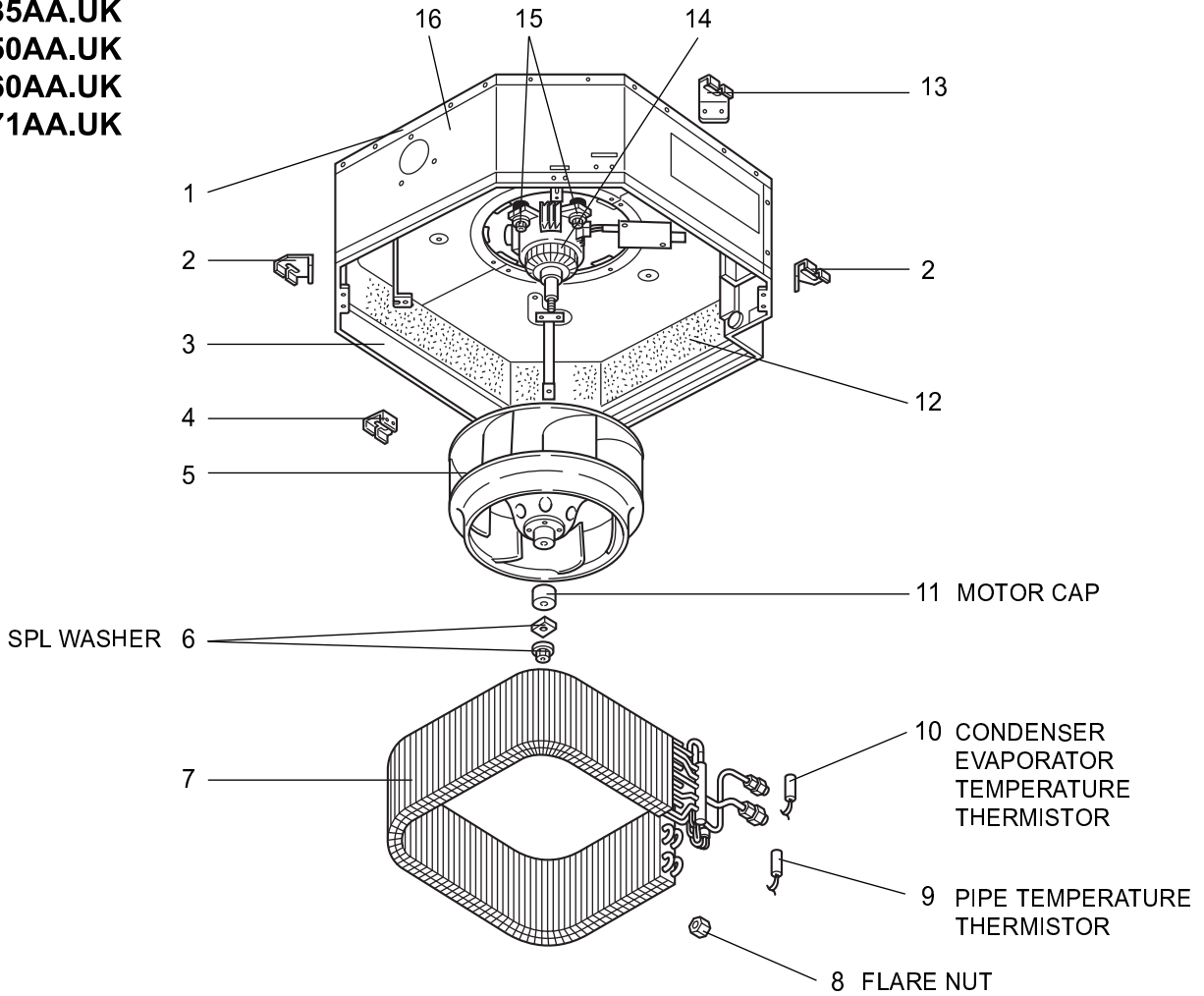

No.	RoHS	Parts No.	Parts Name	Specifi- cation	Q'ty / set			Remarks (Drawing No.)	Wiring Diagram Symbol	Recom- mended Q'ty	Price	
					PLA-RP-AA.UK						Unit	Amount
					35,50	60	71					
1	G	S70 003 687	BASE		1	1	1					
2	G	S70 E01 130	LEG		2	2	2					
3	G	S70 005 688	DRUM 1 ASSY		1	1	1					
4	G	S70 E00 130	LEG		1	1	1					
5	G	S70 E00 114G	TURBO FAN		1	1	1					
6	G	S70 08K 097	SPL WASHER / NUT		1	1	1					
7	G	S70 K16 480G	HEAT EXCHANGER		1							
	G	S70 E17 480G	HEAT EXCHANGER			1						
	G	S70 E40 480G	HEAT EXCHANGER				1					
8	G	S70 E15 097	FLARE NUT	5/8"	1	1	1					
9	G	S70 17J 202	PIPE TEMPERATURE THERMISTOR		1	1	1		TH2			
10	G	S70 E20 202	CONDENSER EVAPORATOR TEMPERATURE THERMISTOR		1	1	1		TH5			
11	G	S70 E50 129	MOTOR CAP		1	1	1					
12	G	S70 E00 659	INNER COVER		1	1	1					
13	G	S70 E02 130	LEG		1	1	1					
14	G	S70 E06 762	FAN MOTOR	D17B6P70MS	1	1	1		MF			
15	G	S70 A41 105	MOTOR MOUNT		4	4	4					
16	G	S70 006 688	DRUM 2 ASSY		1	1	1					

## FUNCTIONAL PARTS

PLA-RP100AA.UK

PLA-RP125AA.UK

PLA-RP140AA.UK

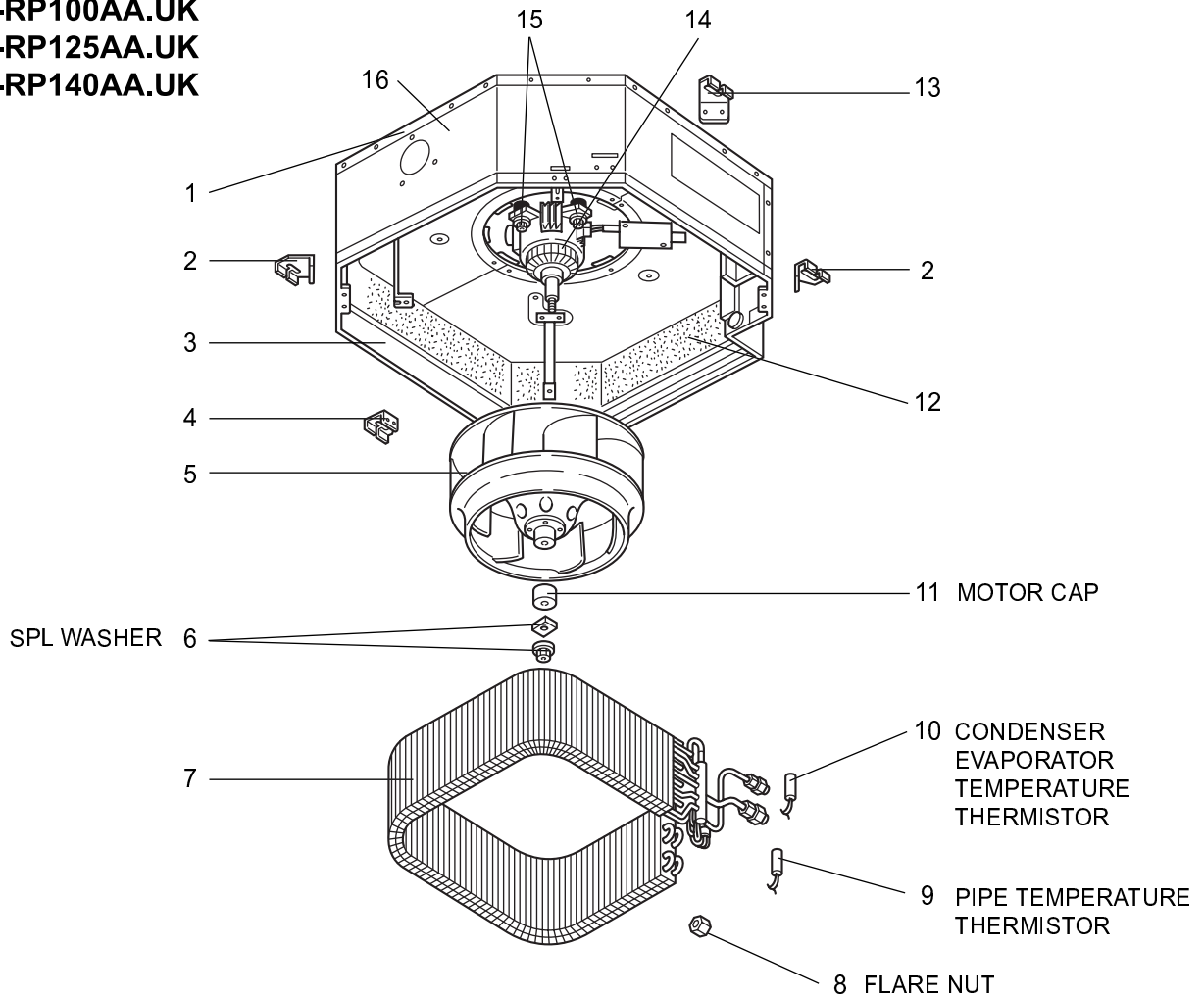

No.	RoHS	Parts No.	Parts Name	Specification	Q'ty / set		Remarks (Drawing No.)	Wiring Diagram Symbol	Recom-mended Q'ty	Price	
					PLA-RP.AA.UK					Unit	Amount
					100	125,140					
1	G	S70 003 687	BASE		1	1					
2	G	S70 E01 130	LEG		2	2					
3	G	S70 007 688	DRUM 1 ASSY		1	1					
4	G	S70 E00 130	LEG		1	1					
5	G	S70 E01 114G	TURBO FAN		1	1					
6	G	S70 08K 097	SPL WASHER		1	1					
7	G	S70 K18 480G	HEAT EXCHANGER		1						
	G	S70 K19 480G	HEAT EXCHANGER			1					
8	G	S70 E16 097	FLARE NUT	3/4"	1	1					
9	G	S70 17J 202	PIPE TEMPERATURE THERMISTOR		1	1		TH2			
10	G	S70 E20 202	CONDENSER EVAPORATOR TEMPERATURE THERMISTOR		1	1		TH5			
11	G	S70 E50 129	MOTOR CAP		1	1					
12	G	S70 E02 659	INNER COVER		1	1					
13	G	S70 E02 130	LEG		1	1					
14	G	S70 E07 762	FAN MOTOR	D176P120MS	1	1		MF			
15	G	S70 A41 105	MOTOR MOUNT		4	4					
16	G	S70 008 688	DRUM 2 ASSY		1	1					

**FUNCTIONAL PARTS**  
**PLH-P35AAH.UK**  
**PLH-P50AAH.UK**  
**PLH-P60AAH.UK**  
**PLH-P71AAH.UK**

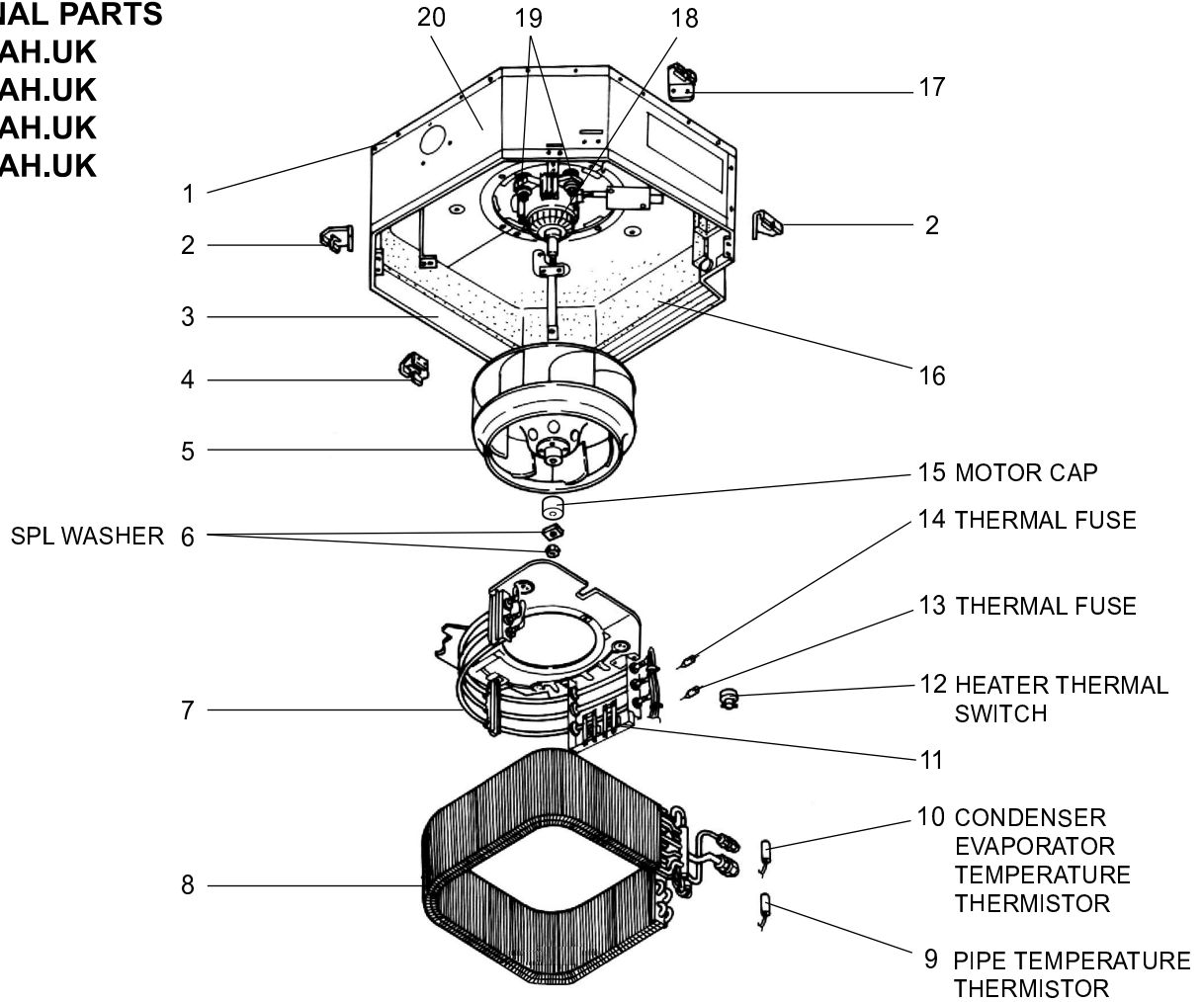

No.	RoHS	Parts No.	Parts Name	Specification	Q'ty / set			Remarks (Drawing No.)	Wiring Diagram Symbol	Recom- mended Q'ty	Price	
					PLH -P-AAH.UK						Unit	Amount
					35,50	60	71					
1	G	S70 003 687	BASE		1	1	1					
2	G	S70 E01 130	LEG		2	2	2					
3	G	S70 005 688	DRUM 1 ASSY		1	1	1					
4	G	S70 E00 130	LEG		1	1	1					
5	G	S70 E00 114G	TURBO FAN		1	1	1					
6	G	S70 08K 097	SPL WASHER		1	1	1					
7	G	S70 E08 300	HEATER ELEMENT	240V/467W	3				H1			
	G	S70 E07 300	HEATER ELEMENT	240V/700W		3	3		H1			
8	G	S70 E20 480G	HEAT EXCHANGER		1	1	1					
9	G	S70 17J 202	PIPE TEMPERATURE THERMISTOR		1	1	1		TH2			
10	G	S70 E20 202	CONDENSER EVAPORATOR TEMPERATURE THERMISTOR		1	1	1		TH5			
11	G	S70 20J 303	INSULATOR		1	1	1					
12	G	S70 46K 700	HEATER THERMAL SWITCH	50°C OFF	1	1	1		26H			
13	G	S70 E02 706	THERMAL FUSE	104°C, 16A	1	1	1		FS2			
14	G	S70 E03 706	THERMAL FUSE	72°C, 16A	1	1	1		FS1			
15	G	S70 E50 129	MOTOR CAP		1	1						
16	G	S70 E01 659	INNER COVER		1	1	1					
17	G	S70 E02 130	LEG		1	1	1					
18	G	S70 E06 762	FAN MOTOR	D17B6P70MS	1	1	1		MF			
19	G	S70 A41 105	MOTOR MOUNT		4	4	4					
20	G	S70 006 688	DRUM 2 ASSY		1	1	1					

**FUNCTIONAL PARTS**  
**PLH-P100AAH.UK**  
**PLH-P125AAH.UK**  
**PLH-P140AAH.UK**

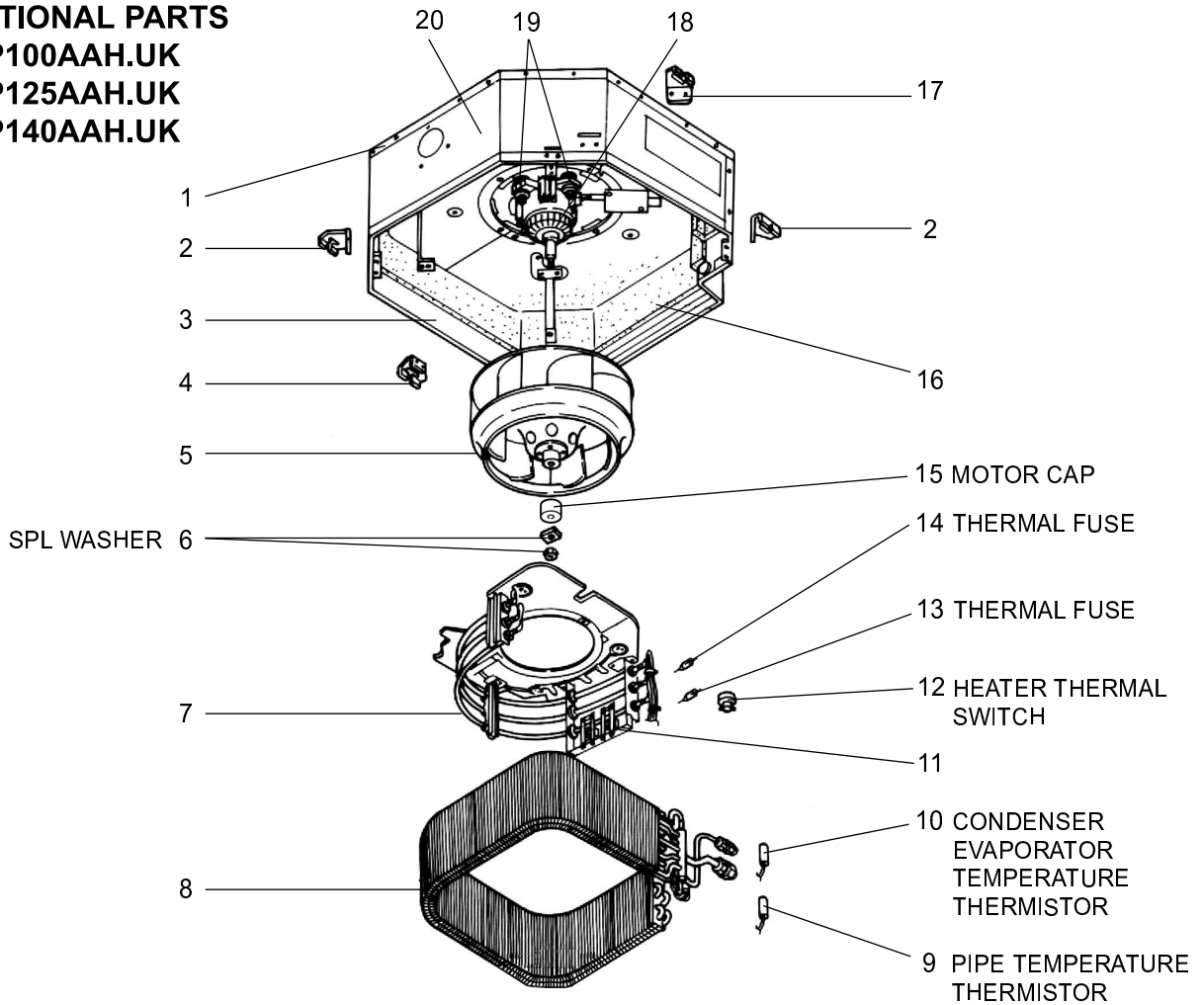

No.	RoHS	Parts No.	Parts Name	Specification	Q'ty / set		Remarks (Drawing No.)	Wiring Diagram Symbol	Recom- mended Q'ty	Price	
					PLH -P-AAH.UK					Unit	Amount
					100	125,140					
1	G	S70 003 687	BASE		1	1					
2	G	S70 E01 130	LEG		2	2					
3	G	S70 007 688	DRUM 1 ASSY		1	1					
4	G	S70 E00 130	LEG		1	1					
5	G	S70 E01 114G	TURBO FAN		1	1					
6	G	S70 08K 097	SPL WASHER		1	1					
7	G	S70 E06 300	HEATER ELEMENT	240V/867W	3			H1			
	G	S70 E05 300	HEATER ELEMENT	240V/1000W		3		H1			
8	G	S70 E21 480G	HEAT EXCHANGER		1						
	G	S70 E25 480G	HEAT EXCHANGER			1					
9	G	S70 17J 202	PIPE TEMPERATURE THERMISTOR		1	1		TH2			
10	G	S70 E20 202	CONDENSER EVAPORATOR TEMPERATURE THERMISTOR		1	1		TH5			
11	G	S70 20J 303	INSULATOR		1	1					
12	G	S70 46K 700	HEATER THERMAL SWITCH	50°C OFF	1	1		26H			
13	G	S70 E02 706	THERMAL FUSE	104°C, 16A	1	1		FS2			
14	G	S70 E04 706	THERMAL FUSE	72°C, 16A	1	1		FS1			
15	G	S70 E50 129	MOTOR CAP		1	1					
16	G	S70 E03 659	INNER COVER		1	1					
17	G	S70 E02 130	LEG		1	1					
18	G	S70 E07 762	FAN MOTOR	D176P120MS	1	1		MF			
19	G	S70 A41 105	MOTOR MOUNT		4	4					
20	G	S70 008 688	DRUM 2 ASSY		1	1					

## FUNCTIONAL PARTS

PLA-RP35AA.UK    PLA-RP100AA.UK  
 PLA-RP50AA.UK    PLA-RP125AA.UK  
 PLA-RP60AA.UK    PLA-RP140AA.UK  
 PLA-RP71AA.UK

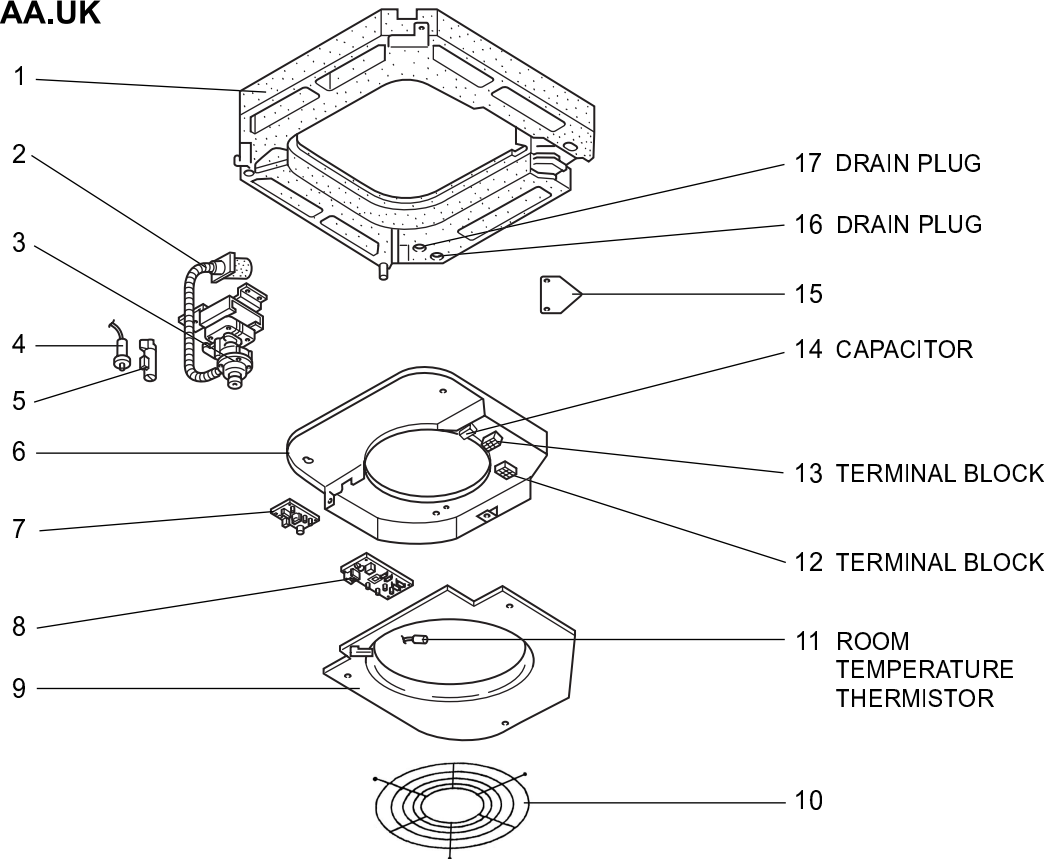

Part number that is circled is not shown in the figure.

No.	RoHS	Parts No.	Parts Name	Specification	Q'ty / set				Remarks (Drawing No.)	Wiring Diagram Symbol	Recom- mended Q'ty	Price	
					PLA-RP · AA.UK							Unit	Amount
					35,50,60	71	100	125,140					
1	G	S70 E02 529	DRAIN PAN		1	1							
	G	S70 E00 529	DRAIN PAN				1						
	G	S70 E01 529	DRAIN PAN					1					
2	G	S70 29H 523	DRAIN SOCKET		1	1	1	1					
3	G	S70 E02 355	DRAIN PUMP		1	1	1	1		DP			
4	G	S70 E00 266	DRAIN SENSOR		1	1	1	1		DS			
5	G	S70 31K 241	DRAIN SENSOR HOLDER		1	1	1	1					
6	G	S70 E30 501	ELECTRICAL CONTROL BOX		1	1	1	1					
7	G	S70 K06 313	POWER BOARD		1	1	1	1		P.B			
8	G	S70 K80 310	INDOOR CONTROLLER BOARD		1	1	1	1		I.B			
9	G	S70 003 503	CONTROL COVER ASSY		1	1	1	1					
10	G	S70 E10 675G	FAN GUARD		1	1	1	1					
11	G	S70 E00 202	ROOM TEMPERATURE THERMISTOR		1	1	1	1		TH1			
12	G	S70 512 716	TERMINAL BLOCK	2P (1, 2)	1	1	1	1		TB5			
13	G	S70 E01 716	TERMINAL BLOCK	3P (S1, S2, S3)	1	1	1	1		TB4			
14	G	S70 576 255	CAPACITOR	3 $\mu$ F 440V	1					C			
	G	S70 17T 255	CAPACITOR	3.5 $\mu$ F 440V		1				C			
	G	S70 E02 255	CAPACITOR	7 $\mu$ F 440V			1	1		C			
15	G	S70 001 663	CORNER COVER		1	1	1	1					
16	G	S70 A48 524	DRAIN PLUG		1	1	1	1					
17	G	S70 A41 524	DRAIN PLUG		1	1	1	1					
18	G	S70 A41 523	DRAIN HOSE ASSY		1	1	1	1					

## FUNCTIONAL PARTS

PLH-P35AAH.UK PLH-P100AAH.UK  
 PLH-P50AAH.UK PLH-P125AAH.UK  
 PLH-P60AAH.UK PLH-P140AAH.UK  
 PLH-P71AAH.UK

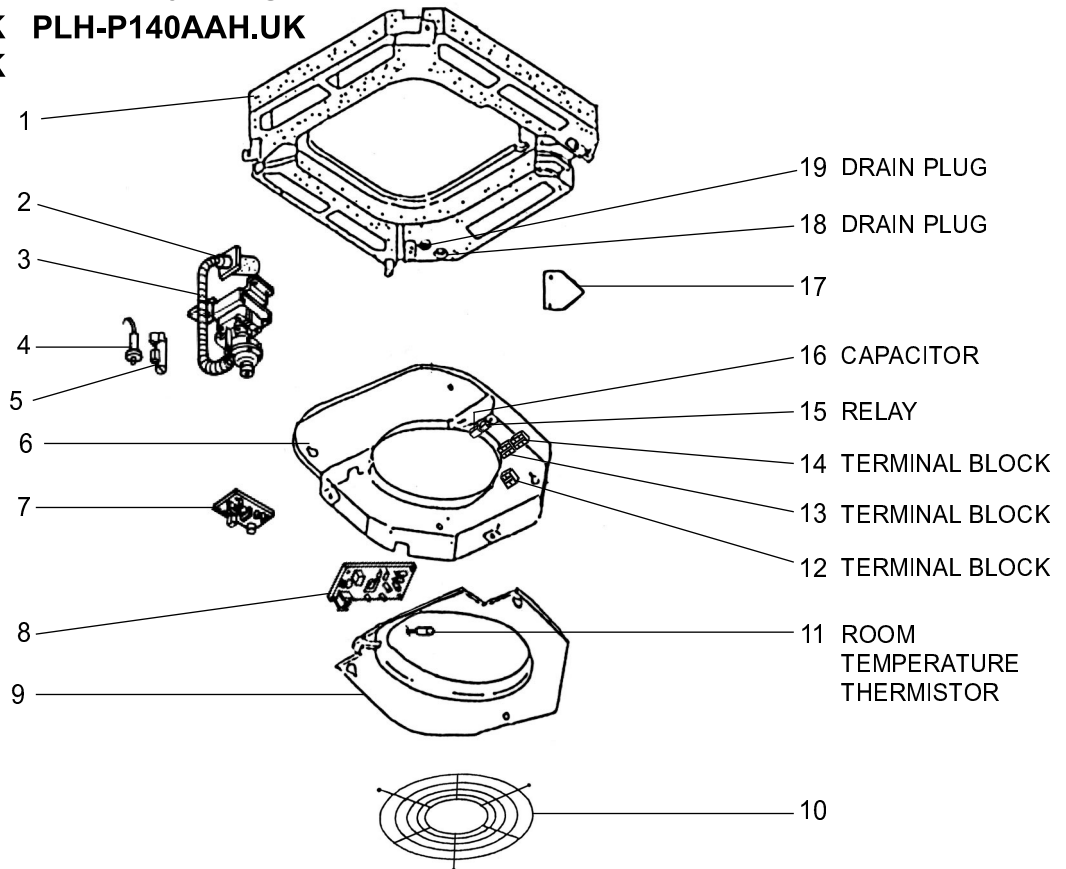

Part number that is circled is not shown in the figure.

No.	RoHS	Parts No.	Parts Name	Specification	Q'ty / set				Remarks (Drawing No.)	Wiring Diagram Symbol	Recom- mended Q'ty	Price	
					PLH -P • AAH.UK							Unit	Amount
					35,50,60	71	100	125,140					
1	G	S70 E02 529	DRAIN PAN		1	1							
	G	S70 E00 529	DRAIN PAN				1						
	G	S70 E01 529	DRAIN PAN					1					
2	G	S70 29H 523	DRAIN SOCKET		1	1	1	1					
3	G	S70 E02 355	DRAIN PUMP		1	1	1	1		DP			
4	G	S70 E00 266	DRAIN SENSOR		1	1	1	1		DS			
5	G	S70 31K 241	DRAIN SENSOR HOLDER		1	1	1	1					
6	G	S70 E30 501	ELECTRICAL CONTROL BOX		1	1	1	1					
7	G	S70 K06 313	POWER BOARD		1	1	1	1		P.B			
8	G	S70 K80 310	INDOOR CONTROLLER BOARD		1	1	1	1		I.B			
9	G	S70 003 503	CONTROL COVER ASSY		1	1	1	1					
10	G	S70 E10 675G	FAN GUARD		1	1	1	1					
11	G	S70 E00 202	ROOM TEMPERATURE THERMISTOR		1	1	1	1		TH1			
12	G	S70 512 716	TERMINAL BLOCK	2P (1, 2)	1	1	1	1		TB5			
13	G	S70 E01 716	TERMINAL BLOCK	3P (S1, S2, S3)	1	1	1	1		TB4			
14	G	S70 521 716	TERMINAL BLOCK	3P (L, N, ⊕)	1	1	1	1		TB2			
15	G	S70 71G 215	RELAY	JC-1A DC12V	1	1	1	1		88H			
16	G	S70 576 255	CAPACITOR	3μF 440V	1					C			
	G	S70 17T 255	CAPACITOR	3.5μF 440V		1				C			
	G	S70 E02 255	CAPACITOR	7.0μF 440V			1	1		C			
17	G	S70 001 663	CORNER COVER		1	1	1	1					
18	G	S70 A41 524	DRAIN PLUG		1	1	1	1					
19	G	S70 A48 524	DRAIN PLUG		1	1	1	1					
20	G	S70 A41 523	DRAIN HOSE ASSY		1	1	1	1					

**Mr. SLIM™**

 **MITSUBISHI ELECTRIC CORPORATION**

HEAD OFFICE : TOKYO BLDG., 2-7-3, MARUNOUCHI, CHIYODA-KU, TOKYO 100-8310, JAPAN