

SPLIT-TYPE, HEAT PUMP AIR CONDITIONERS
SPLIT-TYPE, AIR CONDITIONERS

May 2008

No.OC331
REVISED EDITION-B

SERVICE MANUAL

Series PKA Wall Mounted R407C/R410A

Indoor unit

[Model names] [Service Ref.]

PKA-RP50FAL2	PKA-RP50FAL2	PKA-RP50FAL2#1
PKA-RP60FAL	PKA-RP60FAL	PKA-RP60FAL#1
PKA-RP71FAL	PKA-RP71FAL	PKA-RP71FAL#1
PKA-RP100FAL	PKA-RP100FAL	PKA-RP100FAL#1

Revision:

- PKA-RP50~100FAL(2)#1 are added in REVISED EDITION-B.
- Some descriptions have been modified.

- Please void OC331 REVISED EDITION-A.

Series PKH

R407C

PKH-P60FALH	PKH-P60FALH
PKH-P71FALH	PKH-P71FALH
PKH-P100FALH	PKH-P100FALH

Note:

- This manual describes only service data of the indoor units.
- RoHS compliant products have <G> mark on the spec name plate.
- For servicing of RoHS compliant products, refer to the RoHS Parts List.

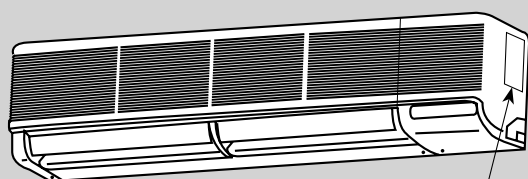

Indoor unit

Model name indication

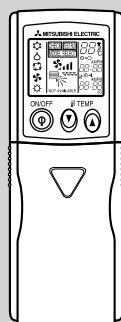

Remote controller

CONTENTS

1. TECHNICAL CHANGES.....	2
2. REFERENCE MANUAL.....	2
3. SAFETY PRECAUTION.....	3
4. PART NAMES AND FUNCTIONS.....	7
5. SPECIFICATIONS.....	8
6. NOISE CRITERION CURVES.....	10
7. OUTLINES AND DIMENSIONS.....	11
8. WIRING DIAGRAM.....	13
9. REFRIGERANT SYSTEM DIAGRAM.....	14
10. TROUBLE SHOOTING.....	15
11. SPECIAL FUNCTION.....	30
12. DISASSEMBLY PROCEDURE.....	33
13. PARTS LIST.....	36
14. RoHS PARTS LIST.....	42

1**TECHNICAL CHANGES**

PKA-RP50FAL2 → PKA-RP50FAL2#1
 PKA-RP60FAL → PKA-RP60FAL#1
 PKA-RP71FAL → PKA-RP71FAL#1
 PKA-RP100FAL → PKA-RP100FAL#1

INDOOR CONTROLLER BOARD(I.B.) has been changed.

2**REFERENCE MANUAL****2-1. OUTDOOR UNIT'S SERVICE MANUAL**

Service Ref.	Service Manual No.
PUHZ-RP35/50/60/71/100/125/140VHA ⁽¹⁾ PUHZ-RP100/125/140YHA	OC334
PUHZ-RP71/100/125/140VHA ⁽¹⁾ -A	OC337
PUHZ-RP200/250YHA ⁽¹⁾⁽²⁾ PUHZ-RP200/250YHA ⁽¹⁾ -A	OC338 OC339
PU(H)-P • VGAA.UK PU(H)-P • YGAA.UK PUHZ-P100/125/140VHA.UK	OC336 OC359
PUHZ-RP35/50/60/71/100/125/140VHA2 ⁽¹⁾ PUHZ-RP100/125/140YHA2 ⁽¹⁾ PUHZ-RP35/50/60/71/100VHA3 PUHZ-RP100YHA3	OC374
PU(H)-P71/100VHA ⁽¹⁾ .UK PU(H)-P100/125/140YHA ⁽¹⁾ .UK PUHZ-P100/125/140VHA2 ⁽¹⁾ .UK	OC379 OCH415 / OCB415
PUHZ-RP71/100/125/140VHA2-A PUHZ-RP100/125/140YHA2-A	OCH422 / OCB422
PUHZ-BP100/125/140VHA-A PUHZ-BP200/250YHA-A	OCH423 / OCB423
PUHZ-P200/250YHA2	OCH424 / OCB424
PUHZ-HRP71/100VHA PUHZ-HRP100/125YHA	OCH425 / OCB425
PUHZ-RP200/250YHA2	OCH428 / OCB428

2-2. TECHNICAL DATA BOOK

Series (Outdoor unit)	Manual No.
PUHZ-RP • HA(-A)	OCS01
PU(H)-P • GAA.UK	OCS02
PUHZ-RP • HA2	OCS05
PUHZ-P • HA	OCS06
PU(H)-P • HA	OCS07
PUHZ-P • VHA2, PUHZ-P • YHA	OCS08
PUHZ-RP • HA2-A	OCS09
PUHZ-BP • HA	OCS10
PUHZ-HRP • HA	OCS11

3-1. ALWAYS OBSERVE FOR SAFETY

Before obtaining access to terminal, all supply circuits must be disconnected.

3-2. CAUTIONS RELATED TO NEW REFRIGERANT

Cautions for units utilizing refrigerant R407C

Do not use the existing refrigerant piping.

The old refrigerant and lubricant in the existing piping contains a large amount of chlorine which may cause the lubricant deterioration of the new unit.

Use "low residual oil piping"

If there is a large amount of residual oil (hydraulic oil, etc.) inside the piping and joints, deterioration of the lubricant will result.

**Store the piping to be used during installation indoors with keep both ends sealed until just before brazing.
(Store elbows and other joints in a plastic bag.)**

If dust, dirt, or water enters the refrigerant cycle, deterioration of the oil and compressor trouble may result.

Use ESTER , ETHER or HAB as the lubricant to coat flares and flange connection parts.

If large amount of mineral oil enter, that can cause deterioration of refrigerant oil etc.

Use liquid refrigerant to seal the system.

If gas refrigerant is used to seal the system, the composition of the refrigerant in the cylinder will change and performance may drop.

Do not use a refrigerant other than R407C.

If another refrigerant (R22, etc.) is used, the chlorine in the refrigerant may cause the lubricant deterioration.

Use a vacuum pump with a reverse flow check valve.

The vacuum pump oil may flow back into the refrigerant cycle and cause the lubricant deterioration.

Ventilate the room if refrigerant leaks during operation. If refrigerant comes into contact with a flame, poisonous gases will be released.

[1] Cautions for service

- After recovering the all refrigerant in the unit, proceed to working.
- Do not release refrigerant in the air.
- After completing the repair service, recharge the cycle with the specified amount of liquid refrigerant.

[2] Refrigerant recharging

(1) Refrigerant recharging process

① Direct charging from the cylinder.

- R407C cylinder are available on the market has a syphon pipe.
- Leave the syphon pipe cylinder standing and recharge it.
(By liquid refrigerant)

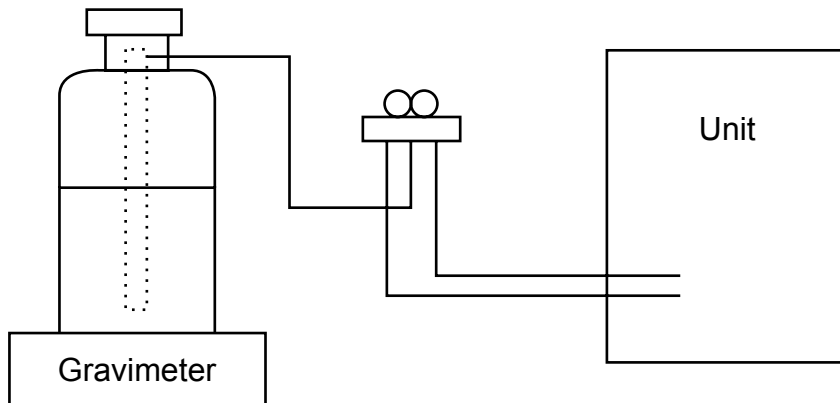

(2) Recharge in refrigerant leakage case

- After recovering the all refrigerant in the unit, proceed to working.
- Do not release the refrigerant in the air.
- After completing the repair service, recharge the cycle with the specified amount of liquid refrigerant.

[3] Service tools

Use the below service tools as exclusive tools for R407C refrigerant.

No.	Tool name	Specifications
①	Gauge manifold	·Only for R407C.
		·Use the existing fitting SPECIFICATIONS. (UNF7/16)
		·Use high-tension side pressure of 3.43MPa-G or over.
②	Charge hose	·Only for R407C.
		·Use pressure performance of 5.10MPa-G or over.
③	Electronic scale	_____
④	Gas leak detector	·Use the detector for R134a or R407C.
⑤	Adapter for reverse flow check.	·Attach on vacuum pump.
⑥	Refrigerant charge base.	_____
⑦	Refrigerant cylinder.	·For R407C ·Top of cylinder (Brown)
		·Cylinder with syphon
⑧	Refrigerant recovery equipment.	_____

CAUTIONS RELATED TO NEW REFRIGERANT

Caution for units utilizing refrigerant R410A

Use new refrigerant pipes.

In case of using the existing pipes for R22, be careful with the followings.

- For PR60/71VHA3 and RP100 be sure to perform replacement operation before test run.
- Change flare nut to the one provided with this product. Use a newly flared pipe.
- Avoid using thin pipes.

Make sure that the inside and outside of refrigerant piping is clean and it has no contamination such as sulfur hazardous for use, oxides, dirt, shaving particles, etc. In addition, use pipes with specified thickness.

Contamination inside refrigerant piping can cause deterioration of refrigerant oil etc.

Store the piping to be used during installation indoors and keep both ends of the piping sealed until just before brazing. (Leave elbow joints, etc. in their packaging.)

If dirt, dust or moisture enter into refrigerant cycle, that can cause deterioration of refrigerant oil or malfunction of compressor.

Use ester oil, ether oil or alkylbenzene oil (small amount) as the refrigerant oil applied to flares and flange connections.

If large amount of mineral oil enter, that can cause deterioration of refrigerant oil etc.

Charge refrigerant from liquid phase of gas cylinder.

If the refrigerant is charged from gas phase, composition change may occur in refrigerant and the efficiency will be lowered.

Do not use refrigerant other than R410A.

If other refrigerant (R22 etc.) is used, chlorine in refrigerant can cause deterioration of refrigerant oil etc.

Use a vacuum pump with a reverse flow check valve.

Vacuum pump oil may flow back into refrigerant cycle and that can cause deterioration of refrigerant oil etc.

Use the following tools specifically designed for use with R410A refrigerant.

The following tools are necessary to use R410A refrigerant.

Tools for R410A	
Gauge manifold	Flare tool
Charge hose	Size adjustment gauge
Gas leak detector	Vacuum pump adaptor
Torque wrench	Electronic refrigerant charging scale

Keep the tools with care.

If dirt, dust or moisture enter into refrigerant cycle, that can cause deterioration of refrigerant oil or malfunction of compressor.

Do not use a charging cylinder.

If a charging cylinder is used, the composition of refrigerant will change and the efficiency will be lowered.

Ventilate the room if refrigerant leaks during operation. If refrigerant comes into contact with a flame, poisonous gases will be released.

[1] Cautions for service

- (1) Perform service after collecting the refrigerant left in unit completely.
- (2) Do not release refrigerant in the air.
- (3) After completing service, charge the cycle with specified amount of refrigerant.
- (4) When performing service, install a filter drier simultaneously.
Be sure to use a filter drier for new refrigerant.

[2] Additional refrigerant charge

When charging directly from cylinder

- Check that cylinder for R410A on the market is syphon type.
- Charging should be performed with the cylinder of syphon stood vertically. (Refrigerant is charged from liquid phase.)

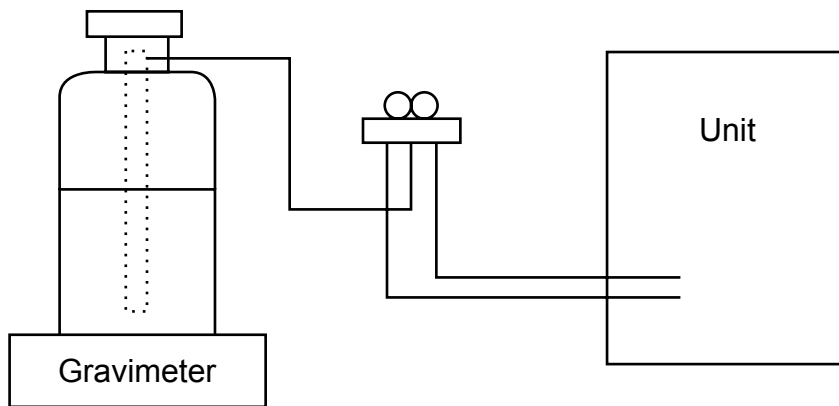

[3] Service tools

Use the below service tools as exclusive tools for R410A refrigerant.

No.	Tool name	Specifications
①	Gauge manifold	·Only for R410A
		·Use the existing fitting specifications. (UNF1/2)
		·Use high-tension side pressure of 5.3MPa-G or over.
②	Charge hose	·Only for R410A
		·Use pressure performance of 5.09MPa-G or over.
③	Electronic scale	—
④	Gas leak detector	·Use the detector for R134a, R407C or R410A.
⑤	Adaptor for reverse flow check	·Attach on vacuum pump.
⑥	Refrigerant charge base	—
⑦	Refrigerant cylinder	·Only for R410A Top of cylinder (Pink)
		Cylinder with syphon
⑧	Refrigerant recovery equipment	—

4

PART NAMES AND FUNCTIONS

Indoor Unit

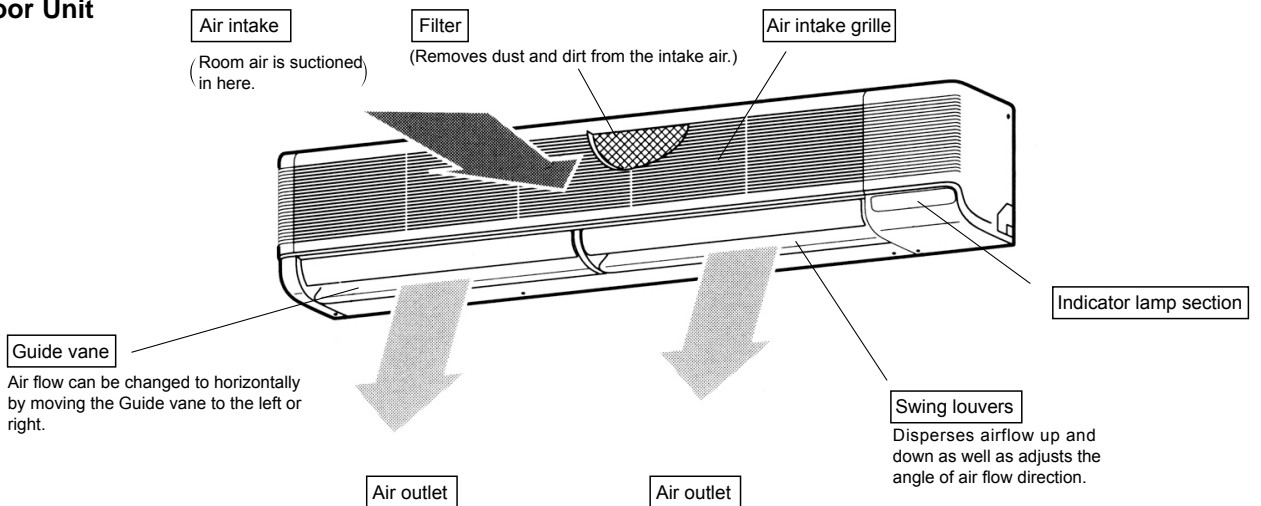

Wireless remote controller

When cover is open.

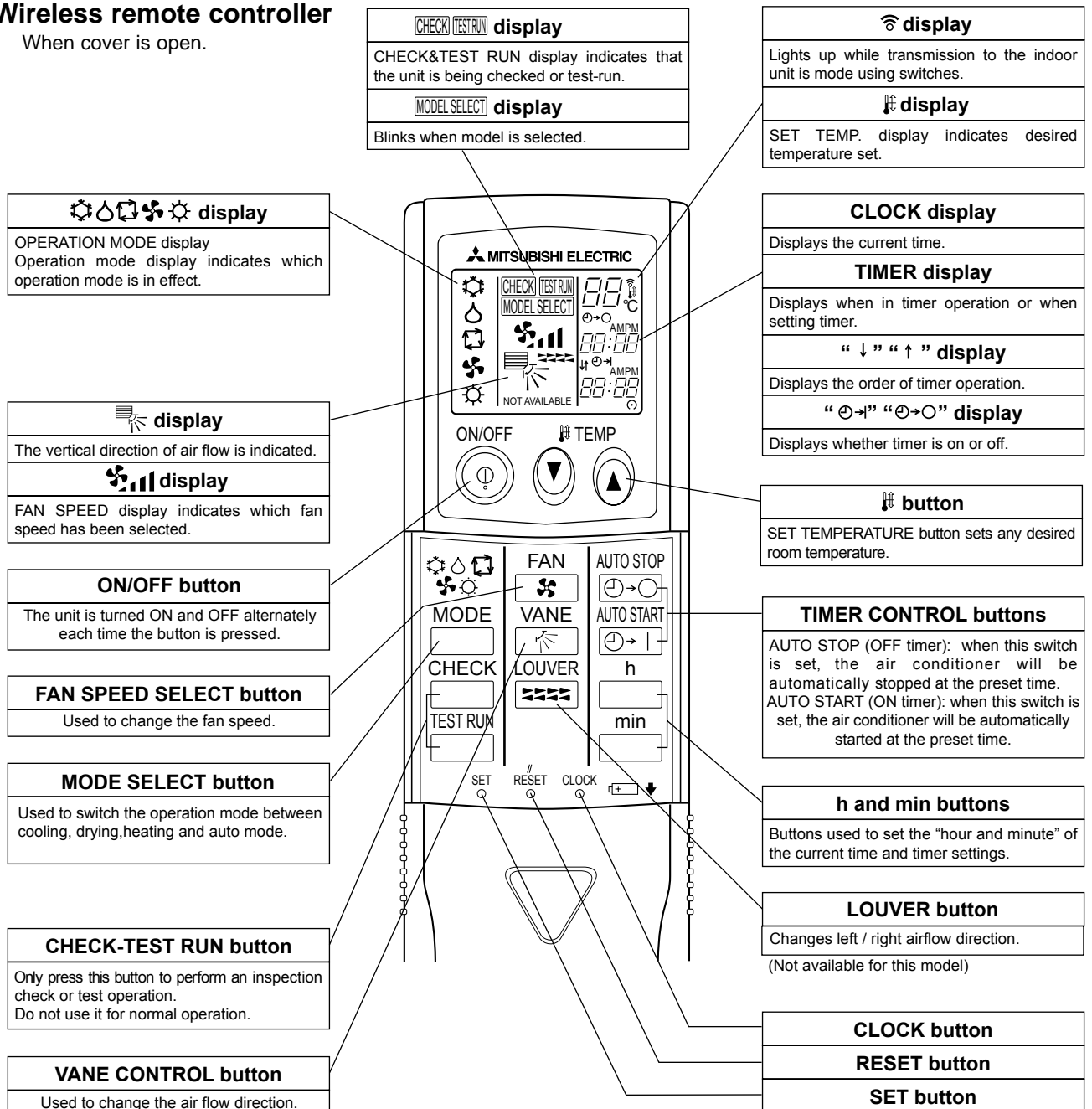

Service Ref.			PKA-RP50FAL2,PKA-RP50FAL2#1 / PKA-RP60FAL,PKA-RP60FAL#1	
Mode			Cooling	Heating
Power supply(phase, cycle, voltage)			Single phase, 50Hz, 230V	
Input	kW		0.09	0.09
Running current	A		0.43	0.43
Starting current	A		0.80	0.80
External finish			Munsell 3.4Y 7.7/0.8	
Heat exchanger			Plate fin coil	
Fan	Fan(drive) x No.		Line flow (direct) x 2	
	Fan motor output	kW	0.040	
	Airflow(Low-High)	m ³ /min(CFM)	15-20(530-705)	
	External static pressure	Pa(mmAq)	0(direct blow)	
Operation control & Thermostat			Wireless remote controller & built-in	
Noise level(Low-High)		dB	39-45	
Unit drain pipe O.D.		mm(in.)	20(13/16)	
Dimensions	W	mm(in.)	1,400(55-1/8)	
	D	mm(in.)	235(9-1/4)	
	H	mm(in.)	340(13-3/8)	
Weight		kg(lbs)	24(53)	

Service Ref.			PKA-RP71FAL,PKA-RP71FAL#1	
Mode			Cooling	Heating
Power supply(phase, cycle, voltage)			Single phase, 50Hz, 230V	
Input	kW		0.09	0.09
Running current	A		0.43	0.43
Starting current	A		0.80	0.80
External finish			Munsell 3.4Y 7.7/0.8	
Heat exchanger			Plate fin coil	
Fan	Fan(drive) x No.		Line flow (direct) x 2	
	Fan motor output	kW	0.040	
	Airflow(Low-High)	m ³ /min(CFM)	15-20(530-706)	
	External static pressure	Pa(mmAq)	0(direct blow)	
Operation control & Thermostat			Wireless remote controller & built-in	
Noise level(Low-High)		dB	39-45	
Unit drain pipe O.D.		mm(in.)	20(13/16)	
Dimensions	W	mm(in.)	1,400(55-1/8)	
	D	mm(in.)	235(9-1/4)	
	H	mm(in.)	340(13-3/8)	
Weight		kg(lbs)	24(53)	

Service Ref.			PKA-RP100FAL,PKA-RP100FAL#1	
Mode			Cooling	Heating
Power supply(phase, cycle, voltage)			Single phase, 50Hz, 230V	
Input	kW		0.11	0.11
Running current	A		0.52	0.52
Starting current	A		0.90	0.90
External finish			Munsell 3.4Y 7.7/0.8	
Heat exchanger			Plate fin coil	
Fan	Fan(drive) x No.		Line flow (direct) x 2	
	Fan motor output	kW	0.070	
	Airflow(Low-High)	m ³ /min(CFM)	22-28(780-990)	
	External static pressure	Pa(mmAq)	0(direct blow)	
Operation control & Thermostat			Wireless remote controller & built-in	
Noise level(Low-High)		dB	41-46	
Unit drain pipe O.D.		mm(in.)	26(1)	
Dimensions	W	mm(in.)	1,680(66-1/8)	
	D	mm(in.)	235(9-1/4)	
	H	mm(in.)	340(13-3/8)	
Weight		kg(lbs)	28(62)	

Service Ref.			PKH-P60FALH	
Mode			Cooling	Heating
Power supply(phase, cycle,voltage)			Single phase, 50Hz, 230V	
Input	※1	kW	0.09	0.09<1.93>
Running current	※1	A	0.43	0.43<8.39>
Starting current	※1	A	0.80	0.80<8.39>
External finish			Munsell 3.4Y 7.7/0.8	
Heat exchanger			Plate fin coil	
INDOOR UNIT	Fan	Fan(drive) x No.	Line flow (direct) x 2	
		Fan motor output	0.040	
		Airflow(Low-High)	15-20 (530-706)	
		External static pressure	0(direct blow)	
Booster heater ※1			kW <1.93>	
Operation control & Thermostat			Wireless remote controller & built-in	
Noise level(Low-High)			dB 39-45	
Unit drain pipe O.D.			mm(in.) 20(13/16)	
Dimensions	W	mm(in.)	1,400(13/16)	
	D	mm(in.)	235(9-1/4)	
	H	mm(in.)	340(13-3/8)	
Weight			kg(lbs) 26(57)	

Service Ref.			PKH-P71FALH	
Mode			Cooling	Heating
Power supply(phase, cycle,voltage)			Single phase, 50Hz, 230V	
Input	※1	kW	0.09	0.09<1.93>
Running current	※1	A	0.43	0.43<8.39>
Starting current	※1	A	0.80	0.80<8.39>
External finish			Munsell 3.4Y 7.7/0.8	
Heat exchanger			Plate fin coil	
INDOOR UNIT	Fan	Fan(drive) x No.	Line flow (direct) x 2	
		Fan motor output	0.040	
		Airflow(Low-High)	15-20 (530-706)	
		External static pressure	0(direct blow)	
Booster heater ※1			kW <1.93>	
Operation control & Thermostat			Wireless remote controller & built-in	
Noise level(Low-High)			dB 39-45	
Unit drain pipe O.D.			mm(in.) 20(13/16)	
Dimensions	W	mm(in.)	1,400(13/16)	
	D	mm(in.)	235(9-1/4)	
	H	mm(in.)	340(13-3/8)	
Weight			kg(lbs) 26(57)	

Service Ref.			PKH-P100FALH	
Mode			Cooling	Heating
Power supply(phase, cycle,voltage)			Single phase, 50Hz, 230V	
Input	※1	kW	0.11	0.11<2.20>
Running current	※1	A	0.52	0.52<9.57>
Starting current	※1	A	0.90	0.90<9.57>
External finish			Munsell 3.4Y 7.7/0.8	
Heat exchanger			Plate fin coil	
INDOOR UNIT	Fan	Fan(drive) x No.	Line flow (direct) x 2	
		Fan motor output	0.070	
		Airflow(Low-High)	22-28(777-988)	
		External static pressure	0(direct blow)	
Booster heater ※1			kW <2.20>	
Operation control & Thermostat			Wireless remote controller & built-in	
Noise level(Low-High)			dB 41-46	
Unit drain pipe O.D.			mm(in.) 20(13/16)	
Dimensions	W	mm(in.)	1,680(66-1/8)	
	D	mm(in.)	235(9-1/4)	
	H	mm(in.)	340(13-3/8)	
Weight			kg(lbs) 30(66)	

※1 : < > Shows the only booster heater rating.

6

NOISE CRITERION CURVES

PKA-RP50FAL2
 PKA-RP50FAL2#1
 PKA-RP60/71FAL
 PKA-RP60/71FAL#1
 PKH-P60/71FALH

NOTCH	SPL(dB)	LINE
High	45	○—○
Low	39	●—●

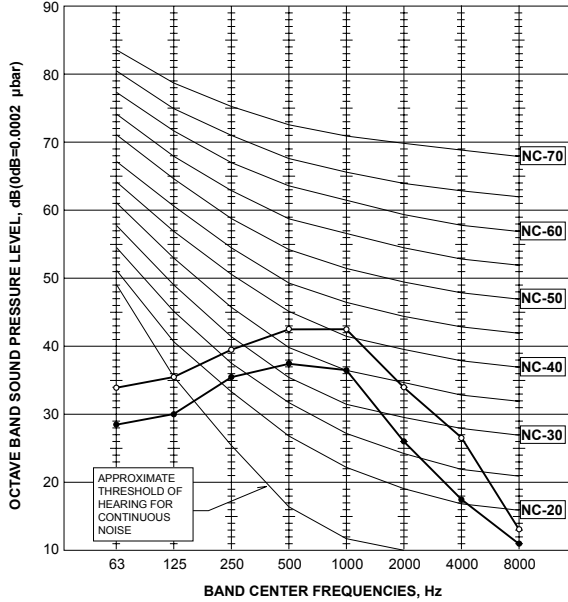

PKA-RP100FAL
 PKA-RP100FAL#1
 PKH-P100FALH

NOTCH	SPL(dB)	LINE
High	46	○—○
Low	41	●—●

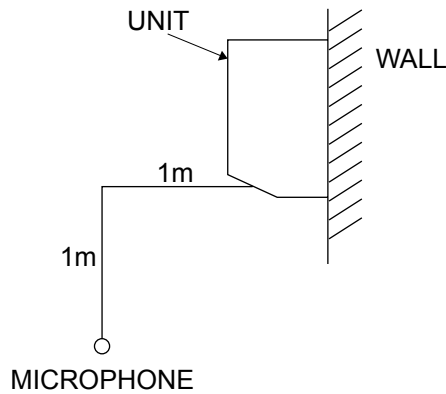
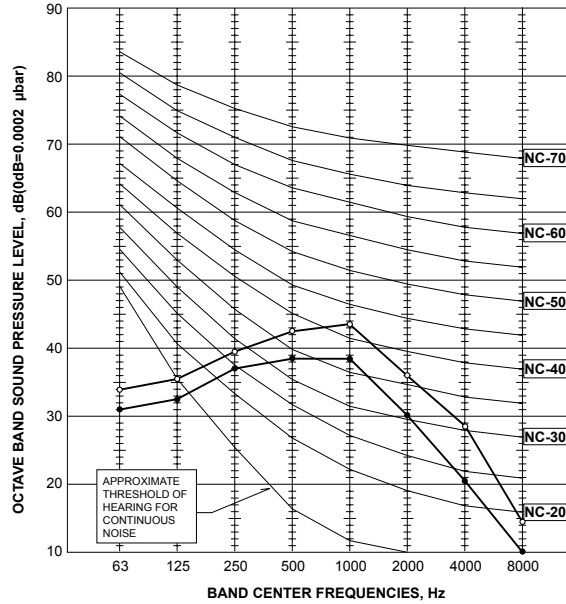

PKA-RP50FAL2 PKA-RP50FAL2#1
 PKH-P60FALH PKA-RP60FAL PKA-RP60FAL#1
 PKH-P71FALH PKA-RP71FAL PKA-RP71FAL#1

Unit : mm

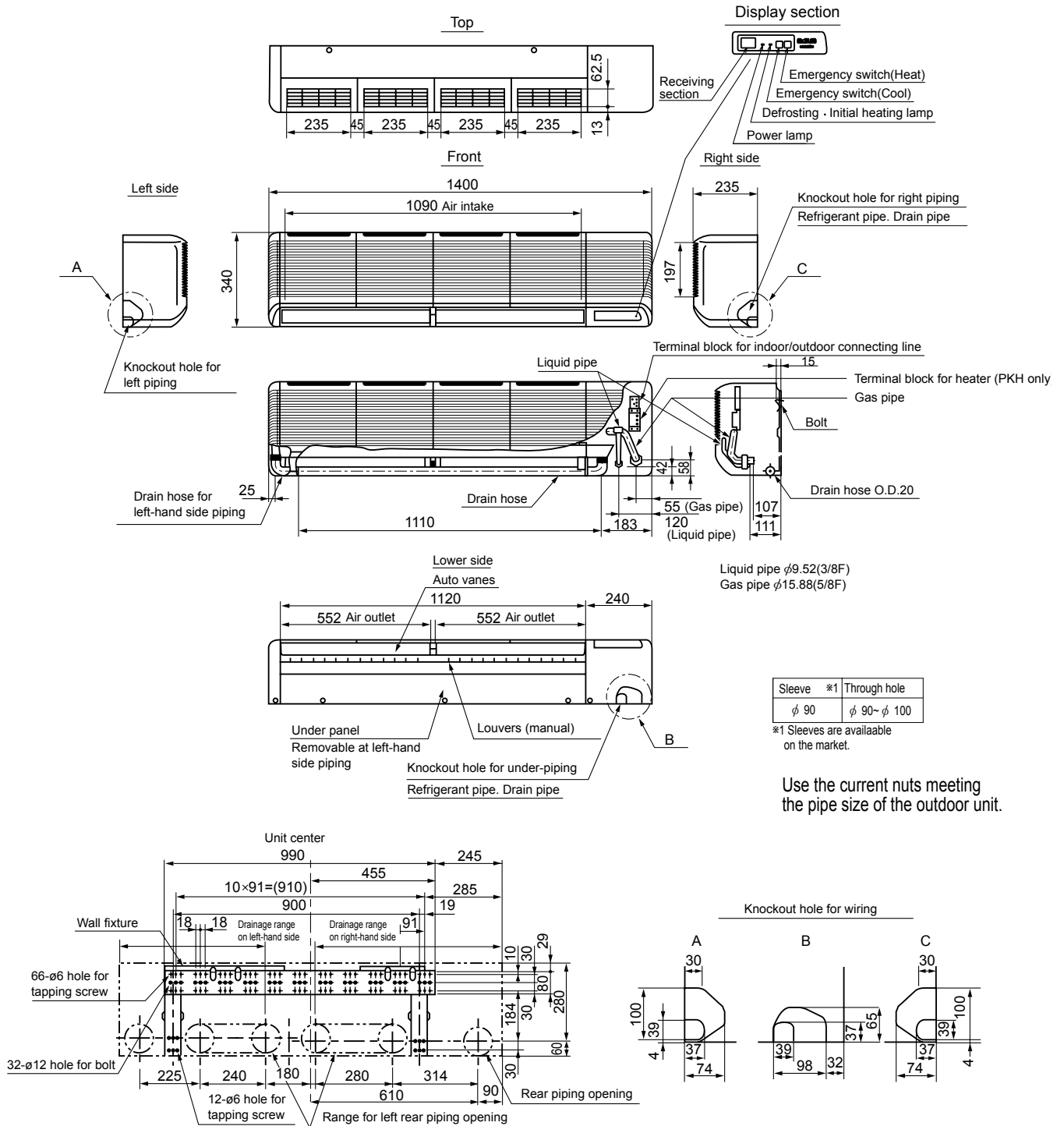

Available pipe size

	RP50	RP60,71 / P60,71
⑤ LIQUID SIDE	$\phi 6.35$ ○	—
	$\phi 9.52$	$\phi 9.52$ ○
⑥ GAS SIDE	$\phi 12.7$ ○	—
	$\phi 15.88$	$\phi 15.88$ ○

○:Initial flare nut size

PKH-P100FALH PKA-RP100FAL PKA-RP100FAL#1

Unit : mm

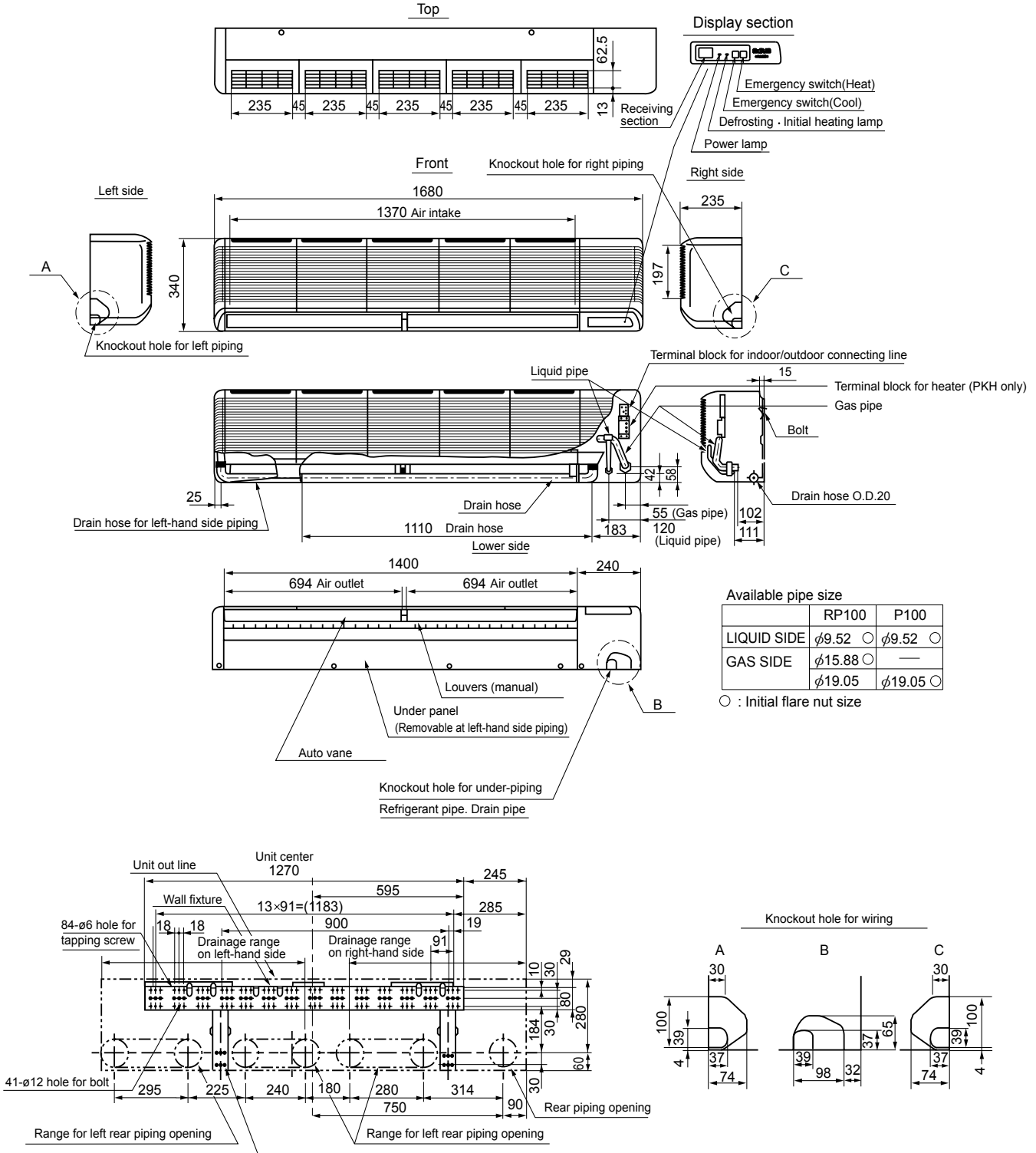

PKA-RP50FAL2 PKA-RP60FAL PKA-RP71FAL PKA-RP100FAL
 PKA-RP50FAL2#1 PKA-RP60FAL#1 PKA-RP71FAL#1 PKA-RP100FAL#1
 PKH-P60FALH PKH-P71FALH PKH-P100FALH

SYMBOL	NAME	SYMBOL	NAME	SYMBOL	NAME
P.B	INDOOR POWER BOARD	C	CAPACITOR(FAN MOTOR)	W.B	WIRELESS REMOTE CONTROLLER BOARD
I.B	INDOOR CONTROLLER BOARD	MF	FAN MOTOR	RU	RECEIVING UNIT
FUSE	FUSE(T6.3AL250V)	MV	VANE MOTOR	BZ	BUZZER
ZNR	VARISTOR	TB2	TERMINAL BLOCK (HEATER) *PKH-P.FALH models only or option for PKA-RP.FAL(2) models.	LED1	LED(RUN INDICATOR)
CN2L	CONNECTOR(LOSSNAY)	TB4	TERMINAL BLOCK(INDOOR/OUTDOOR CONNECTING LINE)	LED2	LED(HOT ADJUST)
CN32	CONNECTOR(REMOTE SWITCH)	TB5	TERMINAL BLOCK(REMOTE CONTROLLER TRANSMISSION LINE)(OPTION)	SW1	SWITCH(HEATING ON/OFF)
CN41	CONNECTOR(HA TERMINAL-A)	TH1	ROOM TEMP.THERMISTOR (0°C/15kΩ, 25°C/5.4kΩ DETECT)	SW2	SWITCH(COOLING ON/OFF)
CN51	CONNECTOR(CENTRALLY CONTROL)	TH2	PIPE TEMP.THERMISTOR/LIQUID (0°C/15kΩ, 25°C/5.4kΩ DETECT)	R.B	WIREDREMOTE CONTROLLER BOARD(OPTION)
SW1	SWITCH (MODEL SELECTION) *See Table 1.	TH5	COND./EVA.TEMP.THERMISTOR (0°C/15kΩ, 25°C/5.4kΩ DETECT)	TB6	TERMINAL BLOCK(REMOTE CONTROLLER TRANSMISSION LINE)
SW2	SWITCH (CAPACITY CODE) *See Table 2.			HEATER	
SWE	SWITCH(EMERGENCY OPERATION)			FS1,2	THERMAL FUSE(117°C 10A:60,71FALH/ 117°C 16A:100FALH)
X4	RELAY(FAN MOTOR)			H1	HEATER
BCR	FAN CONTROL ELEMENT			26H	HEATER THERMAL SWITCH
LED1	POWER SUPPLY(I.B)			88H	HEATER CONTACTOR
LED2	POWER SUPPLY(R.B)				
LED3	TRANSMISSION(INDOOR-OUTDOOR)				

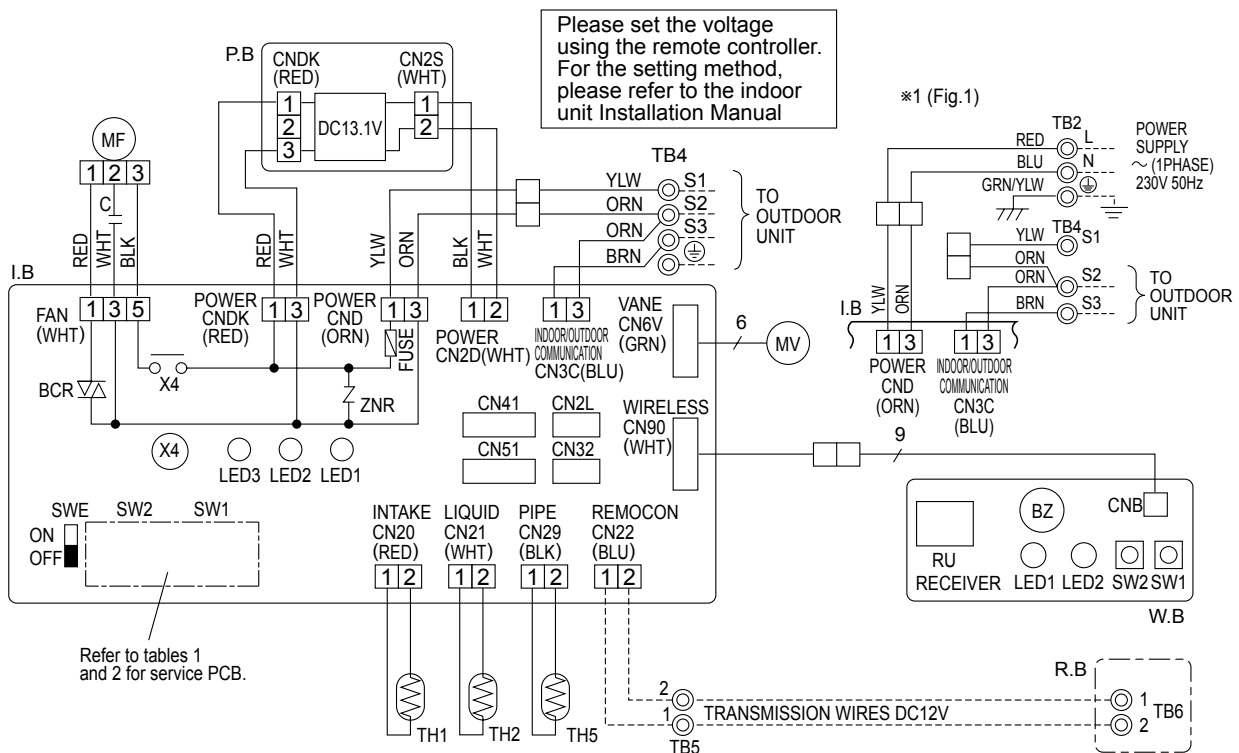

Table 1

SW1										
Service board										
<table border="1"> <tr> <td>1</td><td>2</td><td>3</td><td>4</td><td>5</td> </tr> <tr> <td>ON</td><td>OFF</td><td>ON</td><td>OFF</td><td>ON</td> </tr> </table>	1	2	3	4	5	ON	OFF	ON	OFF	ON
1	2	3	4	5						
ON	OFF	ON	OFF	ON						

Table 2

SW2																									
MODELS		Service board	MODELS		Service board																				
PKA-RP60FAL	PKH-P60FALH	<table border="1"> <tr> <td>1</td><td>2</td><td>3</td><td>4</td><td>5</td> </tr> <tr> <td>ON</td><td>OFF</td><td>ON</td><td>OFF</td><td>ON</td> </tr> </table>	1	2	3	4	5	ON	OFF	ON	OFF	ON	PKA-RP71FAL	PKH-P71FALH	<table border="1"> <tr> <td>1</td><td>2</td><td>3</td><td>4</td><td>5</td> </tr> <tr> <td>ON</td><td>OFF</td><td>ON</td><td>OFF</td><td>ON</td> </tr> </table>	1	2	3	4	5	ON	OFF	ON	OFF	ON
1	2	3	4	5																					
ON	OFF	ON	OFF	ON																					
1	2	3	4	5																					
ON	OFF	ON	OFF	ON																					
PKA-RP50FAL2			PKA-RP100FAL	PKH-P100FALH	<table border="1"> <tr> <td>1</td><td>2</td><td>3</td><td>4</td><td>5</td> </tr> <tr> <td>ON</td><td>OFF</td><td>ON</td><td>OFF</td><td>ON</td> </tr> </table>	1	2	3	4	5	ON	OFF	ON	OFF	ON										
1	2	3	4	5																					
ON	OFF	ON	OFF	ON																					

PKH-P60 ~ P100FALH models only

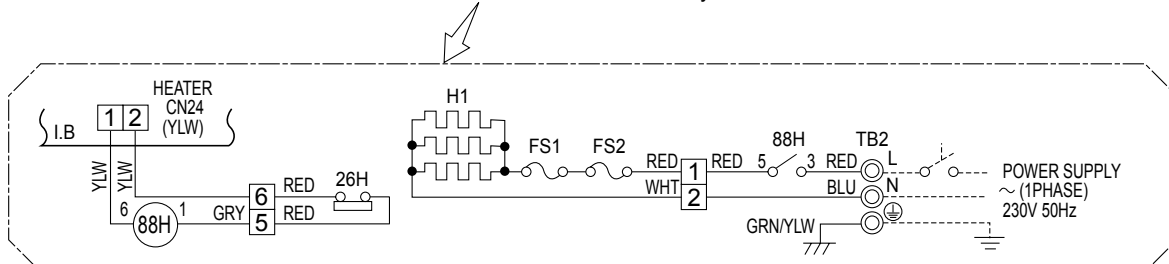

NOTES:

- Since the outdoor side electric wiring may change be sure to check the outdoor unit electric wiring for servicing.
 - Indoor and outdoor connecting wires are made with polarities, make wiring matching terminal numbers (S1, S2, S3).
 - Make sure that the main power supply of the booster heater is independent.
 - Symbols used in wiring diagram above are, □ : Connector, ⊙ : Terminal (block).
- *1. When work to supply power separately to Indoor and Outdoor unit was applied, refer to Fig 1.
 *2. For power supply system of this unit, refer to the caution label located near this diagram.

REFRIGERANT SYSTEM DIAGRAM

PKA-RP50FAL2
 PKA-RP60FAL
 PKA-RP71FAL
 PKA-RP100FAL

PKA-RP50FAL2#1
 PKA-RP60FAL#1
 PKA-RP71FAL#1
 PKA-RP100FAL#1

PKH-P60FALH
 PKH-P71FALH
 PKH-P100FALH

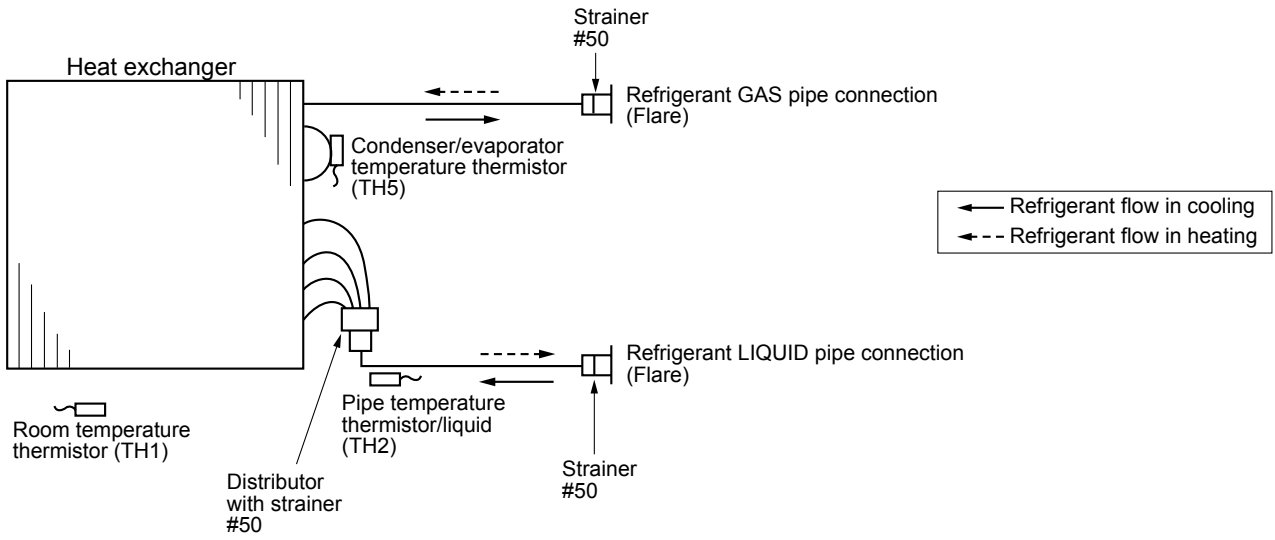

10-1. TROUBLESHOOTING

<Error code display by self-diagnosis and actions to be taken for service (summary)>

Present and past error codes are logged and displayed on the wired remote controller or controller board of outdoor unit. Actions to be taken for service and the trouble recurrence at field are summarized in the table below. Check the contents below before investigating details.

Unit conditions at service	Error code	Actions to be taken for service (summary)
The trouble is reoccurring.	Displayed	Judge what is wrong and take a corrective action according to "SELF-DIAGNOSIS ACTION TABLE" (10-3).
	Not displayed	Conduct troubleshooting and ascertain the cause of the trouble according to "TROUBLESHOOTING BY INFERIOR PHENOMENA" (10-4).
The problem is not reoccurring.	Logged	<ul style="list-style-type: none"> ①Consider the temporary defects such as the work of protection devices in the refrigerant circuit including compressor, poor connection of wiring, noise and etc. Re-check the symptom, and check the installation environment, refrigerant amount, weather when the trouble occurred, matters related to wiring and etc. ②Reset error code logs and restart the unit after finishing service. ③There is no abnormality in electrical component, controller board, remote controller and etc.
	Not logged	<ul style="list-style-type: none"> ①Re-check the abnormal symptom. ②Conduct troubleshooting and ascertain the cause of the trouble according to "TROUBLESHOOTING BY INFERIOR PHENOMENA" (10-4). ③Continue to operate unit for the time being if the cause is not ascertained. ④There is no abnormality concerning of parts such as electrical component, controller board, remote controller and etc.

10-2. MALFUNCTION-DIAGNOSIS METHOD BY REMOTE CONTROLLER



<In case of trouble during operation>

When a malfunction occurs to air conditioner, both indoor unit and outdoor unit will stop and operation lamp blinks to inform unusual stop.

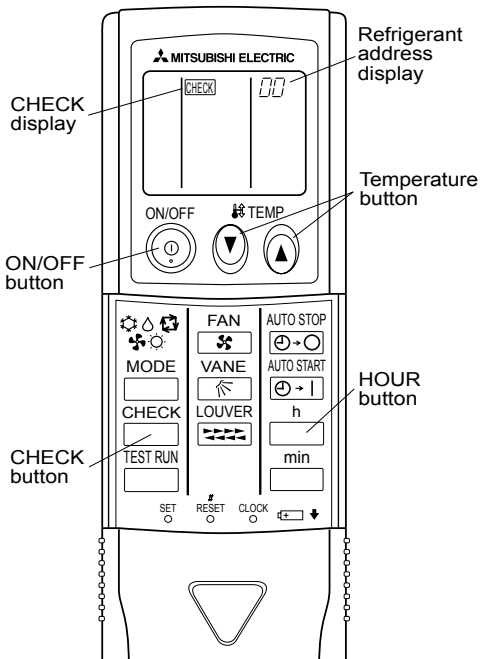
<Malfunction-diagnosis method at maintenance service>



[Procedure]

1. Press the CHECK button twice.
 - "CHECK" lights, and refrigerant address "00" flashes.
 - Check that the remote controller's display has stopped before continuing.
2. Press the temperature   buttons.
 - Select the refrigerant address of the indoor unit for the self-diagnosis.
 - Note: Set refrigerant address using the outdoor unit's DIP switch (SW1). (For more information, see the outdoor unit installation manual.)
3. Point the remote controller at the sensor on the indoor unit and press the HOUR button.
 - If an air conditioner error occurs, the indoor unit's sensor emits an intermittent buzzer sound, the operation light flashes, and the error code is output. (It takes 3 seconds at most for error code to appear.)
4. Point the remote controller at the sensor on the indoor unit and press the ON/OFF button.
 - The check mode is cancelled.

To be continued to the next page.

• Refer to the following tables for details on the check codes.

[Output pattern A]

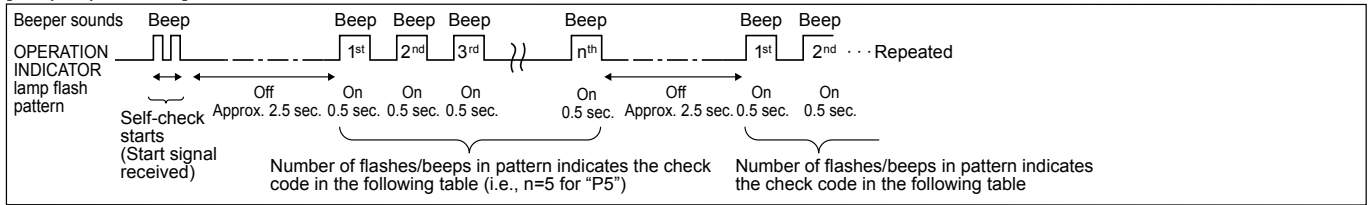

[Output pattern B]

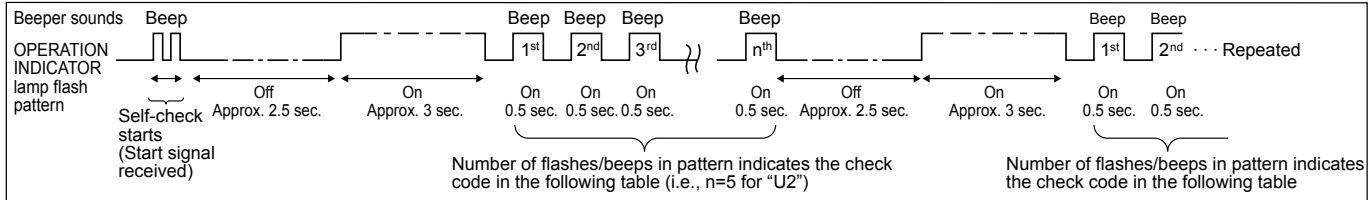

[Output pattern A] Errors detected by indoor unit

Wireless remote controller	Wired remote controller	Symptom	Remark
Beeper sounds/OPERATION INDICATOR lamp flashes (Number of times)	Check code		
1	P1	Intake sensor error	—
2	P2	Pipe (TH2) sensor error	
	P9	Pipe (TH5) sensor error	
3	E6,E7	Indoor/outdoor unit communication error	
4	P4	Drain sensor error	
5	P5	Drain pump error	
	PA	Forced compressor stop(due to water leakage abnormality)	
6	P6	Freezing/Overheating protection operation	
7	EE	Communication error between indoor and outdoor units	
8	P8	Pipe temperature error	
9	E4, E5	Remote controller signal receiving error	
10	-	-	
11	-	-	
12	Fb	Indoor unit control system error (memory error, etc.)	
-	E0, E3	Remote controller transmission error	
-	E1, E2	Remote controller control board error	

[Output pattern B] Errors detected by unit other than indoor unit (outdoor unit, etc.)

Wireless remote controller	Wired remote controller	Symptom	Remark
Beeper sounds/OPERATION INDICATOR lamp flashes (Number of times)	Check code		
1	E9	Indoor/outdoor unit communication error (Transmitting error) (Outdoor unit)	For details, check the LED display of the outdoor controller board. As for outdoor unit, refer to outdoor unit's service manual.
2	UP	Compressor overcurrent interruption	
3	U3,U4	Open/short of outdoor unit thermistors	
4	UF	Compressor overcurrent interruption (When compressor locked)	
5	U2	Abnormal high discharging temperature/49C worked/insufficient refrigerant	
6	U1,Ud	Abnormal high pressure (63H worked)/Overheating protection operation	
7	U5	Abnormal temperature of heat sink	
8	U8	Outdoor unit fan protection stop	
9	U6	Compressor overcurrent interruption/Abnormal of power module	
10	U7	Abnormality of super heat due to low discharge temperature	
11	U9,UH	Abnormality such as overvoltage or voltage shortage and abnormal synchronous signal to main circuit/Current sensor error	
12	-	-	
13	-	-	
14	Others	Other errors (Refer to the technical manual for the outdoor unit.)	

*1 If the beeper does not sound again after the initial 2 beeps to confirm the self-check start signal was received and the OPERATION INDICATOR lamp does not come on, there are no error records.

*2 If the beeper sounds 3 times continuously "beep, beep, beep (0.4 + 0.4 + 0.4 sec.)" after the initial 2 beeps to confirm the self-check start signal was received, the specified refrigerant address is incorrect.

- On wireless remote controller
The continuous buzzer sounds from receiving section of indoor unit.
Blink of operation lamp
- On wired remote controller
Check code displayed in the LCD.

• If the unit cannot be operated properly after test run, refer to the following table to find the cause.

Symptom		LED 1, 2 (PCB in outdoor unit)	Cause
Wired remote controller			
PLEASE WAIT	For about 2 minutes after power-on	After LED 1, 2 are lighted, LED 2 is turned off, then only LED 1 is lighted. (Correct operation)	•For about 2 minutes following power-on, operation of the remote controller is not possible due to system start-up. (Correct operation)
PLEASE WAIT → Error code	Subsequent to about 2 minutes after power-on	Only LED 1 is lighted. → LED 1, 2 blink.	•Connector for the outdoor unit's protection device is not connected. •Reverse or open phase wiring for the outdoor unit's power terminal block (L1, L2, L3)
Display messages do not appear even when operation switch is turned ON (operation lamp does not light up).		Only LED 1 is lighted. → LED 1 blinks twice, LED 2 blinks once.	•Incorrect wiring between indoor and outdoor units (incorrect polarity of S1, S2, S3) •Remote controller wire short

On the wireless remote controller with condition above, following phenomena take place.

- No signals from the remote controller can be received.
- Operation lamp is blinking.
- The buzzer makes a short ping sound.

Note:

Operation is not possible for about 30 seconds after cancellation of function selection. (Correct operation)

For description of each LED (LED1, 2, 3) provided on the indoor controller, refer to the following table.

LED1 (power for microcomputer)	Indicates whether control power is supplied. Make sure that this LED is always lit.
LED2 (power for remote controller)	Indicates whether power is supplied to the remote controller. This LED lights only in the case of the indoor unit which is connected to the outdoor unit refrigerant addresses "0".
LED3 (communication between indoor and outdoor units)	Indicates state of communication between the indoor and outdoor units. Make sure that this LED is always blinking.

10-3. SELF-DIAGNOSIS ACTION TABLE

Note: Refer to the manual of outdoor unit for the details of display such as F, U, and other E.

Error Code	Abnormal point and detection method	Cause	Countermeasure										
P1	<p>Room temperature thermistor (TH1)</p> <p>① The unit is in 3-minute resume prevention mode if short/open of thermistor is detected. Abnormal if the unit does not reset normally after 3 minutes. (The unit returns to normal operation, if it has been reset normally.)</p> <p>② Constantly detected during cooling, drying, and heating operation. Short: -90°C or more Open: -40°C or less</p>	<p>① Defective thermistor characteristics</p> <p>② Contact failure of connector (CN20) on the indoor controller board (Insert failure)</p> <p>③ Breaking of wire or contact failure of thermistor wiring</p> <p>④ Defective indoor controller board</p>	<p>①-③ Check resistance value of thermistor.</p> <table border="1"> <tr><td>0°C</td><td>15.0kΩ</td></tr> <tr><td>10°C</td><td>9.6kΩ</td></tr> <tr><td>20°C</td><td>6.3kΩ</td></tr> <tr><td>30°C</td><td>4.3kΩ</td></tr> <tr><td>40°C</td><td>3.0kΩ</td></tr> </table> <p>If you put force on (draw or bend) the lead wire with measuring resistance value of thermistor, breaking of wire or contact failure can be detected.</p> <p>② Check contact failure of connector (CN20) on the indoor controller board. Refer to 10-7-1. Turn the power on again and check restart after inserting connector again.</p> <p>④ Check room temperature display on remote controller. Replace indoor controller board if there is abnormal difference with actual room temperature.</p> <p>Turn the power off, and on again to operate after check.</p>	0°C	15.0kΩ	10°C	9.6kΩ	20°C	6.3kΩ	30°C	4.3kΩ	40°C	3.0kΩ
0°C	15.0kΩ												
10°C	9.6kΩ												
20°C	6.3kΩ												
30°C	4.3kΩ												
40°C	3.0kΩ												
P2	<p>Pipe temperature thermistor/Liquid (TH2)</p> <p>① The unit is in 3-minute resume prevention mode if short/open of thermistor is detected. Abnormal if the unit does not reset normally after 3 minutes. (The unit returns to normal operation, if it has been reset normally.)</p> <p>② Constantly detected during cooling, drying, and heating (except defrosting) operation Short: 90°C or more Open: -40°C or less</p>	<p>① Defective thermistor characteristics</p> <p>② Contact failure of connector (CN44) on the indoor controller board (Insert failure)</p> <p>③ Breaking of wire or contact failure of thermistor wiring</p> <p>④ Defective refrigerant circuit is causing thermistor temperature of 90°C or more or -40°C or less.</p> <p>⑤ Defective indoor controller board</p>	<p>①-③ Check resistance value of thermistor. For characteristics, refer to (P1) above.</p> <p>② Check contact failure of connector (CN44) on the indoor controller board. Refer to 10-7-1. Turn the power on and check restart after inserting connector again.</p> <p>④ Check pipe <liquid> temperature with remote controller in test run mode. If pipe <liquid> temperature is extremely low (in cooling mode) or high (in heating mode), refrigerant circuit may have defective.</p> <p>⑤ Check pipe <liquid> temperature with remote controller in test run mode. If there is extremely difference with actual pipe <liquid> temperature, replace indoor controller board.</p> <p>Turn the power off, and on again to operate after check.</p>										
P4	<p>Drain sensor (DS)</p> <p>① Suspensive abnormality, if short/open of thermistor is detected for 30 seconds continuously. Compressor and indoor fan will be turned off</p> <p>② Short/open is detected for 30 seconds continuously during suspensive abnormality. (The unit returns to normal operation, if it has normally reset.)</p> <p>③ Detect the following condition.</p> <ul style="list-style-type: none"> • During cooling and drying operation. • In case that pipe <liquid> temperature - room temperature <-10deg (Except defrosting) • When pipe <liquid> temperature or room temperature is short/open temperature. • During drain pump operation. 	<p>① Defective thermistor characteristics</p> <p>② Contact failure of connector (CN31) on the indoor controller board. (Insert failure).</p> <p>③ Breaking of wire or contact failure of drain sensor wiring.</p> <p>④ Defective indoor controller board.</p>	<p>①-③ Check resistance value of thermistor.</p> <table border="1"> <tr><td>0°C</td><td>.....6.0kΩ</td></tr> <tr><td>10°C</td><td>....3.9kΩ</td></tr> <tr><td>20°C</td><td>...2.6kΩ</td></tr> <tr><td>30°C</td><td>...1.8kΩ</td></tr> <tr><td>40°C</td><td>...1.3kΩ</td></tr> </table> <p>② Check contact failure of connector (CN31) on the indoor controller board. Refer to 10-7-1. Turn the power on again and check restart after inserting connector again.</p> <p>④ Replace indoor controller board if drain pump operates with the line of drain sensor connector CN31-① and ② is short-circuited, and abnormality reappears.</p> <p>Turn the power off, and on again to operate after check.</p>	0°C6.0kΩ	10°C3.9kΩ	20°C	...2.6kΩ	30°C	...1.8kΩ	40°C	...1.3kΩ
0°C6.0kΩ												
10°C3.9kΩ												
20°C	...2.6kΩ												
30°C	...1.8kΩ												
40°C	...1.3kΩ												
P5	<p>Malfunction of drain pump (DP)</p> <p>① Suspensive abnormality, if thermistor of drain sensor is let heat itself and temperature rises slightly. Compressor and indoor fan will be turned off.</p> <p>② Drain pump is abnormal if the condition above is detected during suspensive abnormality.</p> <p>③ Constantly detected during drain pump operation.</p>	<p>① Malfunction of drain pump</p> <p>② Defective drain Clogged drain pump Clogged drain pipe</p> <p>③ Attached drop of water at the drain sensor</p> <ul style="list-style-type: none"> • Drops of drain trickles from lead wire. • Clogged filter is causing wave of drain. <p>④ Defective indoor controller board.</p>	<p>① Check if drain-up machine works.</p> <p>② Check drain function.</p> <p>③ Check the setting of lead wire of drain sensor and check clogs of the filter.</p> <p>④ Replace indoor controller board if drain pump operates with the line of drain sensor connector CN31-① and ② is short-circuited and abnormality reappears. Refer to 10-7-1.</p> <p>Turn the power off, and on again to operate after check.</p>										



Error Code	Abnormal point and detection method	Cause	Countermeasure
P6	<p>Freezing/overheating protection is working</p> <p>① Freezing protection (Cooling mode) The unit is in 6-minute resume prevention mode if pipe <liquid or condenser/evaporator> temperature stays under -15°C for 3 minutes, 3 minutes after the compressor started. Abnormal if it stays under -15°C for 3 minutes again within 16 minutes after 6-minute resume prevention mode.</p> <p>② Overheating protection (Heating mode) The units is in 6 minute resume prevention mode if pipe <condenser / evaporator> temperature is detected as over 70°C after the compressor started. Abnormal if the temperature of over 70°C is detected again within 30 minutes after 6 minute resume prevention mode.</p>	<p>(Cooling or drying mode)</p> <p>① Clogged filter (reduced airflow) ② Short cycle of air path ③ Low-load (low temperature) operation out of the tolerance range ④ Defective indoor fan motor • Fan motor is defective. • Indoor controller board is defective.</p> <p>⑤ Defective outdoor fan control ⑥ Overcharge of refrigerant ⑦ Defective refrigerant circuit (clogs)</p> <p>(Heating mode)</p> <p>① Clogged filter (reduced airflow) ② Short cycle of air path ③ Over-load (high temperature) operation out of the tolerance range ④ Defective indoor fan motor • Fan motor is defective. • Indoor controller board is defective. ⑤ Defective outdoor fan control ⑥ Overcharge of refrigerant ⑦ Defective refrigerant circuit (clogs) ⑧ Bypass circuit of outdoor unit is defective.</p>	<p>(Cooling or drying mode)</p> <p>① Check clogs of the filter. ② Remove shields.</p> <p>④ Refer to 10-7-1.</p> <p>⑤ Check outdoor fan motor. ⑥⑦ Check operating condition of refrigerant circuit.</p> <p>(Heating mode)</p> <p>① Check clogs of the filter. ② Remove shields.</p> <p>④ Refer to 10-7-1.</p> <p>⑤ Check outdoor fan motor. ⑥~⑧ Check operating condition of refrigerant circuit.</p>
P8	<p>Pipe temperature <Cooling mode> Detected as abnormal when the pipe temperature is not in the cooling range 3 minutes after compressor start and 6 minutes after the liquid or condenser/evaporator pipe is out of cooling range. Note 1) It takes at least 9 minutes to detect. Note 2) Abnormality P8 is not detected in drying mode. Cooling range : -3 °C ≧ (TH-TH1) TH: Lower temperature between: liquid pipe temperature (TH2) and condenser/evaporator temperature (TH5) TH1: Intake temperature</p> <p><Heating mode> When 10 seconds have passed after the compressor starts operation and the hot adjustment mode has finished, the unit is detected as abnormal when condenser/evaporator pipe temperature is not in heating range within 20 minutes.</p> <p>Note 3) It takes at least 27 minutes to detect abnormality. Note 4) It excludes the period of defrosting. (Detection restarts when defrosting mode is over.) Heating range : 3 °C ≦ (TH5-TH1)</p>	<p>① Slight temperature difference between indoor room temperature and pipe <liquid or condenser / evaporator> temperature thermistor • Shortage of refrigerant • Disconnected holder of pipe <liquid or condenser / evaporator> thermistor • Defective refrigerant circuit</p> <p>② Converse connection of extension pipe (on plural units connection)</p> <p>③ Converse wiring of indoor/outdoor unit connecting wire (on plural units connection)</p> <p>④ Defective detection of indoor room temperature and pipe <condenser / evaporator> temperature thermistor</p> <p>⑤ Stop valve is not opened completely.</p>	<p>①~④ Check pipe <liquid or condenser / evaporator> temperature with room temperature display on remote controller and outdoor controller circuit board. Pipe <liquid or condenser / evaporator> temperature display is indicated by setting SW2 of outdoor controller circuit board as follows.</p> <p>(Conduct temperature check with outdoor controller circuit board after connecting 'A-Control Service Tool(PAC-SK52ST)')</p> <p>②③ Check converse connection of extension pipe or converse wiring of indoor/outdoor unit connecting wire.</p>



Error Code	Abnormal point and detection method	Cause	Countermeasure
P9	<p>Pipe temperature thermistor / Condenser-Evaporator (TH5)</p> <p>① The unit is in 3-minute resume protection mode if short/open of thermistor is detected. Abnormal if the unit does not get back to normal within 3 minutes. (The unit returns to normal operation, if it has been reset normally.)</p> <p>② Constantly detected during cooling, drying, and heating operation (except defrosting) Short: 90°C or more Open: -40°C or less</p>	<p>① Defective thermistor characteristics</p> <p>② Contact failure of connector (CN29) on the indoor controller board (Insert failure)</p> <p>③ Breaking of wire or contact failure of thermistor wiring</p> <p>④ Temperature of thermistor is 90°C or more or -40°C or less caused by defective refrigerant circuit.</p> <p>⑤ Defective indoor controller board</p>	<p>①-③ Check resistance value of thermistor. For characteristics, refer to (P1) above.</p> <p>② Check contact failure of connector (CN29) on the indoor controller board. Refer to 10-7-1. Turn the power on and check restart after inserting connector again.</p> <p>④ Operate in test run mode and check pipe <condenser / evaporator> temperature with outdoor controller circuit board. If pipe <condenser / evaporator> temperature is extremely low (in cooling mode) or high (in heating mode), refrigerant circuit may have defect.</p> <p>⑤ Operate in test run mode and check pipe <condenser / evaporator> temperature with outdoor control circuit board. If there is extreme difference with actual pipe <condenser / evaporator> temperature, replace indoor controller board. There is no abnormality if none of above comes within the unit. Turn the power off and on again to operate.</p> <p>(In case of checking pipe temperature with outdoor controller circuit board, be sure to connect A-control service tool (PAC-SK52ST).)</p>
E0 or E4	<p>Remote controller transmission error(E0)/signal receiving error(E4)</p> <p>① Abnormal if main or sub remote controller cannot receive any transmission normally from indoor unit of refrigerant address "0" for 3 minutes. (Error code : E0)</p> <p>② Abnormal if sub remote controller could not receive any signal for 2 minutes. (Error code: E0)</p> <p>① Abnormal if indoor controller board can not receive any data normally from remote controller board or from other indoor controller board for 3 minutes. (Error code: E4)</p> <p>② Indoor controller board cannot receive any signal from remote controller for 2 minutes. (Error code: E4)</p>	<p>① Contact failure at transmission wire of remote controller</p> <p>② All remote controllers are set as "sub" remote controller. In this case, E0 is displayed on remote controller, and E4 is displayed at LED (LED1, LED2) on the outdoor controller circuit board.</p> <p>③ Miswiring of remote controller</p> <p>④ Defective transmitting receiving circuit of remote controller</p> <p>⑤ Defective transmitting receiving circuit of indoor controller board of refrigerant addresses "0".</p> <p>⑥ Noise has entered into the transmission wire of remote controller.</p>	<p>① Check disconnection or looseness of indoor unit or transmission wire of remote controller.</p> <p>② Set one of the remote controllers "main" if there is no problem with the action above.</p> <p>③ Check wiring of remote controller. • Total wiring length: max. 500m (Do not use cable x 3 or more.) • The number of connecting indoor units: max. 16 units • The number of connecting remote controller: max. 2 units</p> <p>When it is not the above-mentioned problem of ①-③</p> <p>④ Diagnose remote controllers. a) When "RC OK" is displayed, Remote controllers have no problem. Turn the power off, and on again to check. If abnormality generates again, replace indoor controller board. b) When "RC NG" is displayed, Replace remote controller. c) When "RC E3" or "ERC 00-66" is displayed, noise may be causing abnormality. * If the unit is not normal after replacing indoor controller board in group control, indoor controller board of address "0" may be abnormal.</p>
E3 or E5	<p>Remote controller transmission error(E3)/signal receiving error(E5)</p> <p>① Abnormal if remote controller could not find blank of transmission path for 6 seconds and could not transmit. (Error code: E3)</p> <p>② Remote controller receives transmitted data at the same time and compares the received and transmitted data. Abnormal if these data are judged to be different 30 continuous times. (Error code: E3)</p> <p>① Abnormal if indoor controller board could not find blank of transmission path. (Error code: E5)</p> <p>② Indoor controller board receives transmitted data at the same time and compares the received and transmitted data. Abnormal if these data are judged to be different 30 continuous times. (Error code: E5)</p>	<p>① 2 remote controllers are set as "main." (In case of 2 remote controllers)</p> <p>② Remote controller is connected with 2 indoor units or more.</p> <p>③ Repetition of refrigerant address</p> <p>④ Defective transmitting receiving circuit of remote controller</p> <p>⑤ Defective transmitting receiving circuit of indoor controller board</p> <p>⑥ Noise has entered into transmission wire of remote controller.</p>	<p>① Set a remote controller to main, and the other to sub.</p> <p>② Remote controller is connected with only one indoor unit.</p> <p>③ The address changes to a separate setting.</p> <p>④-⑥ Diagnose remote controller. a) When "RC OK" is displayed, remote controllers have no problem. Turn the power off, and on again to check. When becoming abnormal again, replace indoor controller board. b) When "RC NG" is displayed, replace remote controller. c) When "RC E3" or "ERC 00-66" is displayed, noise may be causing abnormality.</p>



Error Code	Abnormal point and detection method	Cause	Countermeasure
E6	<p>Indoor/outdoor unit communication error (Signal receiving error)</p> <p>① Abnormal if indoor controller board cannot receive any signal normally for 6 minutes after turning the power on.</p> <p>② Abnormal if indoor controller board cannot receive any signal normally for 3 minutes.</p> <p>③ Consider the unit abnormal under the following condition: When 2 or more indoor units are connected to an outdoor unit, indoor controller board cannot receive a signal for 3 minutes from outdoor controller circuit board, a signal which allows outdoor controller circuit board to transmit signals.</p>	<p>① Contact failure, short circuit or, miswiring (converse wiring) of indoor/outdoor unit connecting wire</p> <p>② Defective transmitting receiving circuit of indoor controller board</p> <p>③ Defective transmitting receiving circuit of indoor controller board</p> <p>④ Noise has entered into indoor/outdoor unit connecting wire.</p>	<p>* Check LED display on the outdoor control circuit board. (Connect A-control service tool, PAC-SK52ST.) Refer to outdoor unit service manual.</p> <p>① Check disconnection or looseness of indoor/outdoor unit connecting wire of indoor unit or outdoor unit. Check all the units in case of twin triple indoor unit system.</p> <p>②-④ Turn the power off, and on again to check. If abnormality generates again, replace indoor controller board or outdoor controller circuit board.</p> <p>* Other indoor controller board may have defect in case of twin triple indoor unit system.</p>
E7	<p>Indoor/outdoor unit communication error (Transmitting error)</p> <p>Abnormal if "1" receiving is detected 30 times continuously though indoor controller board has transmitted "0".</p>	<p>① Defective transmitting receiving circuit of indoor controller board</p> <p>② Noise has entered into power supply.</p> <p>③ Noise has entered into outdoor control wire.</p>	<p>①-③ Turn the power off, and on again to check. If abnormality generates again, replace indoor controller board.</p>
Fb	<p>Indoor controller board</p> <p>Abnormal if data cannot be read normally from the nonvolatile memory of the indoor controller board.</p>	<p>① Defective indoor controller board</p>	<p>① Replace indoor controller board.</p>
E1 or E2	<p>Remote controller control board</p> <p>① Abnormal if data cannot be read normally from the nonvolatile memory of the remote controller control board. (Error code: E1)</p> <p>② Abnormal if the clock function of remote controller cannot be operated normally. (Error code: E2)</p>	<p>① Defective remote controller</p>	<p>① Replace remote controller.</p>
PA	<p>Forced compressor stop (due to water leakage abnormality)</p> <p>① When the intake temperature subtracted with liquid pipe temperature is less than -10°C, drain sensor is detected whether it is soaked in the water or not at the interval of 90 seconds. (Drain pump will start operating when the drain sensor is detected to be soaked in the water.)</p> <p>② The unit has a water leakage abnormality when the following conditions, a and b, are satisfied while the above-mentioned detection is performed.</p> <p>a) The drain sensor is detected to be soaked in the water 10 times in a row.</p> <p>b) The intake temperature subtracted with liquid pipe temperature is detected to be less than -10°C for a total of 30 minutes. (When the drain sensor is detected to be NOT soaked in the water, the detection record of a and b will be cleared.)</p> <p>③ The drain sensor detection is performed in operations other than cooling. (When the unit stops operating, during heating or fan operation, when the unit stops because of some abnormality)</p> <p>*Once the water leakage abnormality is detected, abnormality state will not be released until the main power is reset.</p>	<p>① Drain pump trouble</p> <p>② Drain defective</p> <ul style="list-style-type: none"> · Drain pump clogging · Drain pipe clogging <p>③ Open circuit of drain sensor side heater</p> <p>④ Contact failure of drain sensor connector</p> <p>⑤ Dew condensation on drain sensor</p> <ul style="list-style-type: none"> · Drain water descends along lead wire. · Drain water waving due to filter clogging. <p>⑥ Extension piping connection difference at twin, triple, quadruple system.</p> <p>⑦ Mis-wiring of indoor/ outdoor connecting at twin, triple, quadruple system.</p> <p>⑧ Room temperature thermistor / liquid pipe temperature thermistor detection is defective.</p>	<p>① Check the drain pump.</p> <p>② Please confirm whether water can be drained.</p> <p>③ Confirm the resistance of the drain sensor.</p> <p>④ Check the connector contact failure.</p> <p>⑤ Check the drain sensor leadwire mounted. Check the filter clogging</p> <p>⑥ Check the piping connection.</p> <p>⑦ Check the indoor/ outdoor connecting wires.</p> <p>⑧ Check the room temperature display of remote controller. Check the indoor liquid pipe temperature display of outdoor controller board.</p>

10-4. TROUBLESHOOTING BY INFERIOR PHENOMENA

Note: Refer to the manual of outdoor unit for the detail of remote controller.



Phenomena	Cause	Countermeasure
(1)LED2 on indoor controller board is off.	<ul style="list-style-type: none"> • When LED1 on indoor controller board is also off. <p>① Power supply of rated voltage is not supplied to outdoor unit.</p> <p>② Defective outdoor controller circuit board.</p> <p>③ Power supply of 220~240V is not supplied to indoor unit.</p> <p>④ Defective indoor power board.</p> <p>⑤ Defective indoor controller board.</p> <p>(For the separate indoor/outdoor unit power supply system)</p> <p>① Power supply of 220~240V AC is not supplied to indoor unit.</p> <p>② The connectors of the optional replacement kit are not used.</p> <p>③ Defective indoor controller board.</p> <p>④ Defective indoor power board.</p>	<p>① Check the voltage of outdoor power supply terminal block (L, N) or (L₃, N).</p> <ul style="list-style-type: none"> • When AC 220~240V is not detected. Check the power wiring to outdoor unit and the breaker. • When AC 220~240V is detected. —Check ② (below). <p>② Check the voltage between outdoor terminal block S1 and S2.</p> <ul style="list-style-type: none"> • When AC 220~240V is not detected. Check the fuse on outdoor controller circuit board. Check the wiring connection. • When AC 220~240V is detected. —Check ③ (below). <p>③ Check the voltage between indoor terminal block S1 and S2.</p> <ul style="list-style-type: none"> • When AC 220~240V is not detected. Check indoor/outdoor unit connecting wire for mis-wiring. • When AC 220~240V is detected. —Check ④ (below). <p>④ Check voltage output from CN2S on indoor power board (DC13.1V). Refer to 10-7-2.</p> <ul style="list-style-type: none"> • When no voltage is output. Check the wiring connection. • When output voltage is between DC12.5V and DC13.7V. —Check ⑤ (below). <p>⑤ Check the wiring connection between indoor controller board and indoor power board. Check the fuse on indoor controller board. If no problems are found, indoor controller board is defective.</p>
	<ul style="list-style-type: none"> • When LED1 on indoor controller board is lit. <p>① Mis-setting of refrigerant address for outdoor unit (There is no unit corresponding to refrigerant address "0".)</p>	<p>① Reconfirm the setting of refrigerant address for outdoor unit. Set the refrigerant address to "0". (For grouping control system under which 2 or more outdoor units are connected, set one of the units to "0".) Set refrigerant address using SW1 (3-6) on outdoor controller circuit board.</p>

Note: Refer to the manual of outdoor unit for the detail of remote controller.

Phenomena	Cause	Countermeasure
(2)LED2 on indoor controller board is blinking.	<ul style="list-style-type: none"> • When LED1 on indoor controller board is also blinking. Connection failure of indoor/outdoor unit connecting wire • When LED1 is lit. <p>① Mis-wiring of remote controller wires Under twin triple indoor unit system, 2 or more indoor units are wired together.</p> <p>② Refrigerant address for outdoor unit is wrong or not set. Under grouping control system, there are some units whose refrigerant address is 0.</p> <p>③ Short-cut of remote controller wires</p> <p>④ Defective remote controller</p>	<p>Check indoor/outdoor unit connecting wire for connection failure.</p> <p>① Check the connection of remote controller wires in case of twin triple indoor unit system. When 2 or more indoor units are wired in one refrigerant system, connect remote controller wires to one of those units.</p> <p>② Check the setting of refrigerant address in case of grouping control system. If there are some units whose refrigerant addresses are 0 in one group, set one of the units to 0 using SW1 (3-6) on outdoor controller circuit board.</p> <p>③④ Remove remote controller wires and check LED2 on indoor controller board.</p> <ul style="list-style-type: none"> • When LED2 is blinking, check the short-cut of remote controller wires. • When LED2 is lit, connect remote controller wires again and: if LED2 is blinking, remote controller is defective; if LED2 is lit, connection failure of remote controller terminal block etc. has returned to normal.
(3)Upward/downward vane performance failure	<p>① The vane is not downward during defrosting and heat preparation and when the thermostat is OFF in HEAT mode. (Working of COOL protection function)</p> <p>② Vane motor does not rotate.</p> <ul style="list-style-type: none"> • Defective vane motor • Breaking of wire or connection failure of connector • Up/down vane setting is "No vanes". <p>③ Upward/downward vane does not work.</p> <ul style="list-style-type: none"> • The vane is set to fixed position. 	<p>① Normal operation (The vane is set to horizontal regardless of remote control.)</p> <p>② Check ② (left).</p> <ul style="list-style-type: none"> • Check the vane motor. (Refer to "How to check the parts".) • Check for breaking of wire or connection failure of connector. • Check "Up/down vane setting". (Unit function selection by remote controller). <p>③ Normal operation (Each connector on vane motor side is disconnected.)</p>
(4)Receiver for wireless remote controller	<p>① Weak batteries of wireless remote controller.</p> <p>② Contact failure of connector (CNB) on wireless remote controller board. (Insert failure)</p> <p>③ Contact failure of connector (CN90) on indoor controller board.(Insert failure)</p> <p>④ Contact failure of connector between wireless remote controller board and indoor controller board.</p>	<p>① Replace batteries of wireless remote controller.</p> <p>②~④ Check contact failure of each connector. If no problems are found of connector, replace indoor controller board. When the same trouble occurs even if indoor controller board is replaced, replace wireless remote controller board.</p>

10-5. EMERGENCY OPERATION

10-5-1. When wireless remote controller troubles or its battery is exhausted

- Emergency operation is available in such a case using emergency operation switch equipped next to the receiver of indoor unit.
 - To start operation
 - Cooling Operation.....Press  (Cooling) switch.
 - Heating Operation.....Press  (Heating) switch.
- *When the unit starts operating, the power lamp is lit.

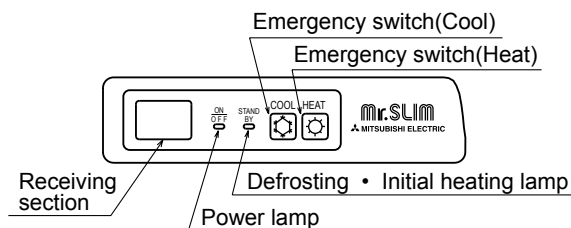

*Emergency operation will be performed as follows.

Mode	Cooling	Heating
Set temperature	24°C	24°C
Fan speed	High	High
Airflow direction	Horizontal (30deg)	Downward (70deg)

- To stop operation
 - Press either emergency operation switch (cooling/heating).

10-5-2. When wired remote controller or indoor unit micro computer troubles

- If there is not any other wrong when trouble occurs, emergency operation starts as the indoor controller board switch (SWE) is set to ON.

During the emergency operation the indoor unit is as follows;

(1) Indoor fan high speed operation (2) Drain-up machine operation(Optional)
- When emergency operating for COOL or HEAT, setting of the switch (SWE) in the indoor controller board and outdoor unit emergency operation are necessary.
- Check items and notices as the emergency operation
 - Emergency operation cannot be used as follows;
 - When the outdoor unit is something wrong.
 - When the indoor fan is something wrong.
 - When drain over flow protected operation is detected during self-diagnosis. (Error code : P5)
 - Emergency operation will be serial operation by the power supply ON/OFF.

ON/OFF or temperature, etc. adjustment is not operated by the remote controller.
 - Do not operate for a long time as cold air is blown when the outdoor unit starts defrosting operation during heat emergency operation.
 - Cool emergency operation must be within 10 hours at most. It may cause heat exchanger frosting in the indoor unit.
 - After completing the emergency operation, return the switch setting, etc. in former state.
 - Since vane does not work at emergency operation, position the vane manually and slowly.

10-6. HOW TO CHECK THE PARTS

PKH-P60FALH
PKA-RP50FAL2
PKA-RP50FAL2#1

PKH-P71FALH
PKA-RP60FAL
PKA-RP60FAL#1

PKH-P100FALH
PKA-RP71FA
PKA-RP71FAL#1

PKA-RP100FAL
PKA-RP100FAL#1

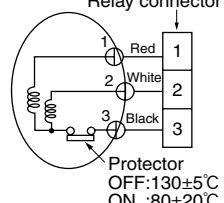
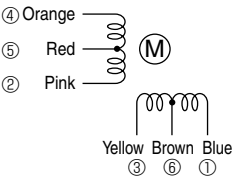
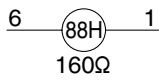
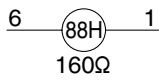
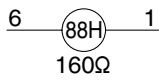
Parts name	Check points													
Room temperature thermistor (TH1) Pipe temperature thermistor (TH2) Condenser/evaporator temperature thermistor (TH5)	Disconnect the connector then measure the resistance with a tester. (Surrounding temperature 10°C ~30°C) <table border="1" style="margin-left: 20px;"> <tr> <td>Normal</td> <td>Abnormal</td> </tr> <tr> <td>4.3kΩ~9.6kΩ</td> <td>Open or short</td> </tr> </table>	Normal	Abnormal	4.3kΩ~9.6kΩ	Open or short									
Normal	Abnormal													
4.3kΩ~9.6kΩ	Open or short													
Fan motor 	Measure the resistance between the terminals with a tester. (Winding temperature 20°C) <table border="1" style="margin-left: 20px;"> <tr> <td rowspan="2">Motor terminal or Relay connector</td> <td colspan="2">Normal</td> <td rowspan="2">Abnormal</td> </tr> <tr> <td>50, 60, 71</td> <td>100</td> </tr> <tr> <td>Red-Black</td> <td>99.5Ω</td> <td>62.6Ω</td> <td rowspan="2">Open or short</td> </tr> <tr> <td>White-Black</td> <td>103.9Ω</td> <td>74.0Ω</td> </tr> </table>	Motor terminal or Relay connector	Normal		Abnormal	50, 60, 71	100	Red-Black	99.5Ω	62.6Ω	Open or short	White-Black	103.9Ω	74.0Ω
Motor terminal or Relay connector	Normal		Abnormal											
	50, 60, 71	100												
Red-Black	99.5Ω	62.6Ω	Open or short											
White-Black	103.9Ω	74.0Ω												
Vane motor 	Measure the resistance between the terminals with a tester. (Surrounding temperature 20°C ~30°C) <table border="1" style="margin-left: 20px;"> <tr> <td>Connector</td> <td>Normal</td> <td>Abnormal</td> </tr> <tr> <td>Brown-Yellow</td> <td rowspan="4">186~214Ω</td> <td rowspan="4">Open or short</td> </tr> <tr> <td>Brown-Blue</td> </tr> <tr> <td>Red-Orange</td> </tr> <tr> <td>Red-Pink</td> </tr> </table>	Connector	Normal	Abnormal	Brown-Yellow	186~214Ω	Open or short	Brown-Blue	Red-Orange	Red-Pink				
Connector	Normal	Abnormal												
Brown-Yellow	186~214Ω	Open or short												
Brown-Blue														
Red-Orange														
Red-Pink														
Heater (Only PKH)	Measure the resistance of each heater element with a tester. <table border="1" style="margin-left: 20px;"> <tr> <td colspan="2">Normal</td> <td>Abnormal</td> </tr> <tr> <td>60, 71</td> <td>100</td> <td rowspan="3">Open or short</td> </tr> <tr> <td>18.9Ω</td> <td>16.5Ω</td> </tr> <tr> <td>700W 240V</td> <td>800W 240V</td> </tr> </table>	Normal		Abnormal	60, 71	100	Open or short	18.9Ω	16.5Ω	700W 240V	800W 240V			
Normal		Abnormal												
60, 71	100	Open or short												
18.9Ω	16.5Ω													
700W 240V	800W 240V													
Contactors (for heater) (Only PKH)	Measure the resistance between the terminals with a tester. <table border="1" style="margin-left: 20px;"> <tr> <td>Normal</td> <td>Abnormal</td> </tr> <tr> <td></td> <td>Open or short</td> </tr> </table>	Normal	Abnormal		Open or short									
Normal	Abnormal													
	Open or short													

<Thermistor Characteristic graph>

Thermistor for lower temperature

Room temperature thermistor(TH1)
Pipe temperature thermistor(TH2)
Condenser/evaporator temperature thermistor(TH5)

Thermistor $R_0=15k\Omega \pm 3\%$

Fixed number of $B=3480 \pm 2\%$

$$R_t = 15 \exp \left\{ 3480 \left(\frac{1}{273+t} - \frac{1}{273} \right) \right\}$$

0°C	15kΩ
10°C	9.6kΩ
20°C	6.3kΩ
25°C	5.4kΩ
30°C	4.3kΩ
40°C	3.0kΩ

< Thermistor for lower temperature >

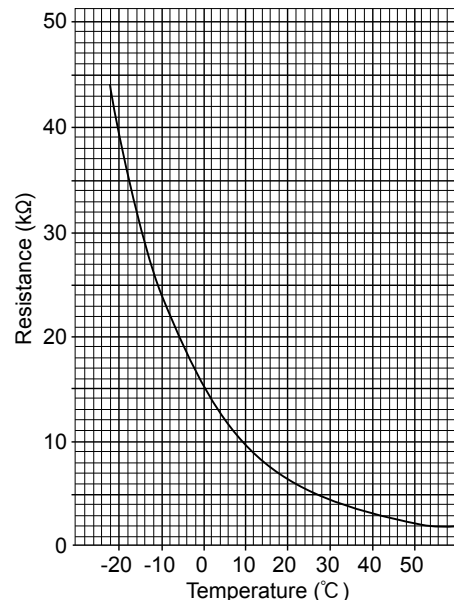

10-7. TEST POINT DIAGRAM

10-7-1. Indoor controller board

PKA-RP50FAL2
 PKA-RP60FAL
 PKA-RP71FAL
 PKA-RP100FAL

PKA-RP50FAL2#1
 PKA-RP60FAL#1
 PKA-RP71FAL#1
 PKA-RP100FAL#1

PKH-P60FALH
 PKH-P71FALH
 PKH-P100FALH

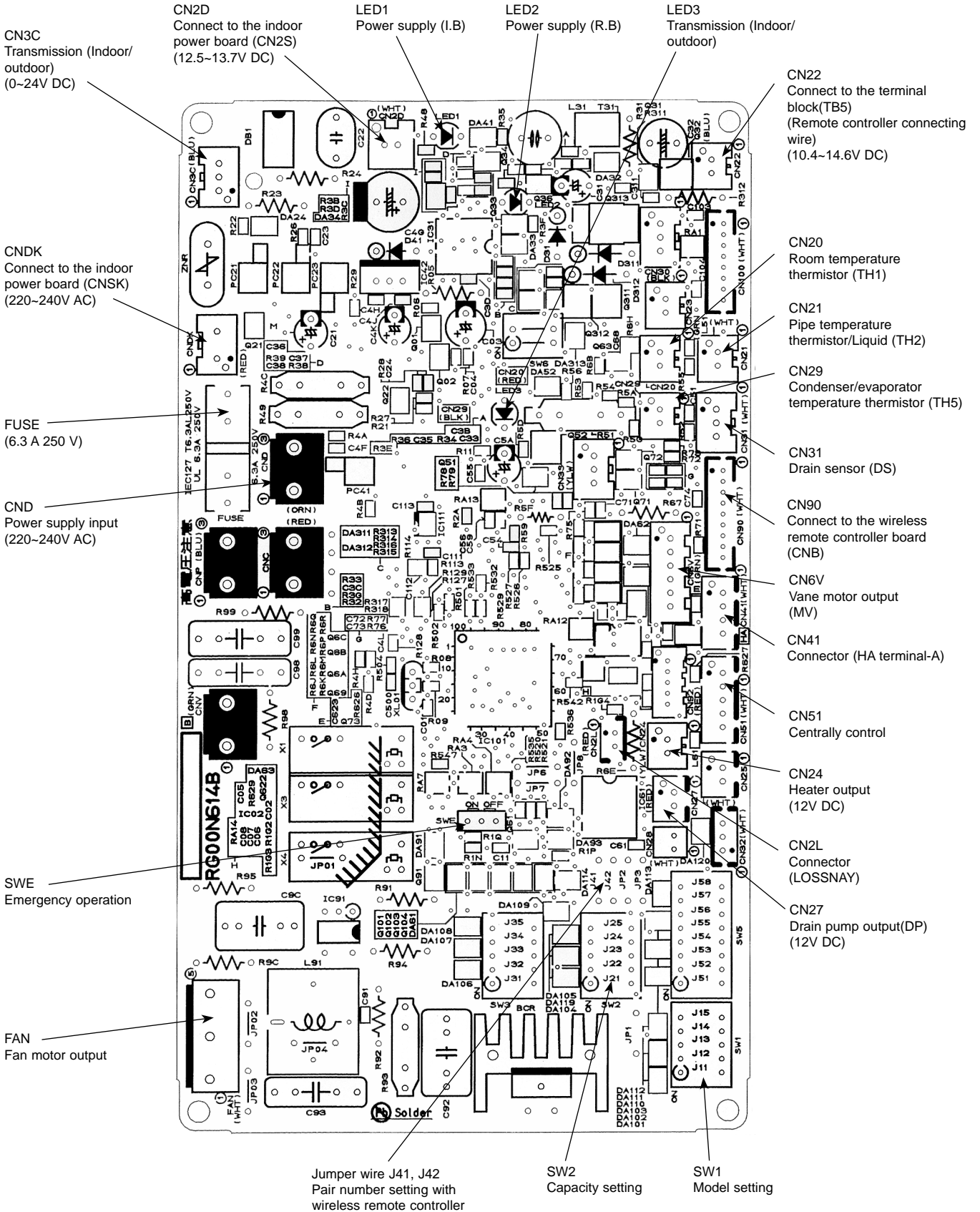

10-7-2. Indoor power board

PKA-RP50FAL2 PKA-RP50FAL2#1
 PKA-RP60FAL PKA-RP60FAL#1 PKH-P60FALH
 PKA-RP71FAL PKA-RP71FAL#1 PKH-P71FALH
 PKA-RP100FAL PKA-RP100FAL#1 PKH-P100FALH

CN2S
 Connect to the indoor controller board (CN2D)
 Between ① to ③ 12.6-13.7V DC (Pin① (+))

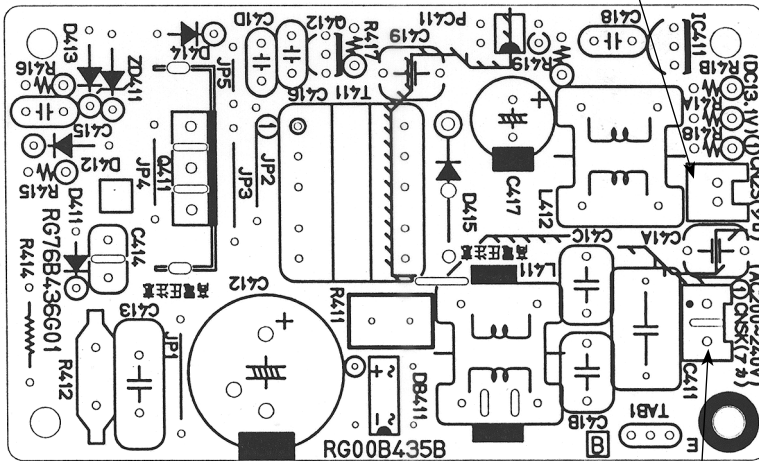

CNSK
 Connect to the indoor controller board
 (CNDK)
 Between ① to ③ 220-240V AC









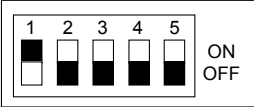

10-8. FUNCTIONS OF DIP SWITCH AND JUMPER WIRE

Each function is controlled by the dip switch and the jumper wire on control p.c. board.

SW1 and SW2 are equipped only for service parts.

Model setting and capacity setting are memorized in the nonvolatile memory of the control p.c. board of the unit.

(Marks in the table below) Jumper wire (○ : Short × : Open)

Jumper wire	Functions	Setting by the dip switch and jumper wire	Remarks																	
SW1	Model settings	For service board 																		
SW2	Capacity settings	<table border="1"> <thead> <tr> <th>Models</th> <th>Service board</th> </tr> </thead> <tbody> <tr> <td>PKA-RP60FAL PKH-P60FALH PKA-RP50FAL2</td> <td></td> </tr> <tr> <td>PKA-RP71FAL PKH-P71FALH</td> <td></td> </tr> <tr> <td>PKA-RP100FAL PKH-P100FALH</td> <td></td> </tr> </tbody> </table>	Models	Service board	PKA-RP60FAL PKH-P60FALH PKA-RP50FAL2		PKA-RP71FAL PKH-P71FALH		PKA-RP100FAL PKH-P100FALH											
Models	Service board																			
PKA-RP60FAL PKH-P60FALH PKA-RP50FAL2																				
PKA-RP71FAL PKH-P71FALH																				
PKA-RP100FAL PKH-P100FALH																				
J41 J42	Pair number setting with wireless remote controller	<table border="1"> <thead> <tr> <th rowspan="2">Wireless remote controller setting</th> <th colspan="2">Control PCB setting</th> </tr> <tr> <th>J41</th> <th>J42</th> </tr> </thead> <tbody> <tr> <td>0</td> <td>○</td> <td>○</td> </tr> <tr> <td>1</td> <td>×</td> <td>○</td> </tr> <tr> <td>2</td> <td>○</td> <td>×</td> </tr> <tr> <td>3 ~ 9</td> <td>×</td> <td>×</td> </tr> </tbody> </table>	Wireless remote controller setting	Control PCB setting		J41	J42	0	○	○	1	×	○	2	○	×	3 ~ 9	×	×	<p><Initial setting> Wireless remote controller: 0 Control PCB: ○ (for both J41 and J42) Four pair number settings are supported. The pair number settings of the wireless remote controller and indoor control PCB (J41/J42) are given in the table on the left. ('×' in the table indicates the jumper line is disconnected.)</p>
Wireless remote controller setting	Control PCB setting																			
	J41	J42																		
0	○	○																		
1	×	○																		
2	○	×																		
3 ~ 9	×	×																		
JP1	Unit type setting	<table border="1"> <thead> <tr> <th>Model</th> <th>JP1</th> </tr> </thead> <tbody> <tr> <td>Without TH5</td> <td>○</td> </tr> <tr> <td>With TH5</td> <td>×</td> </tr> </tbody> </table>	Model	JP1	Without TH5	○	With TH5	×	There is no jumper (JP1) because these models have the cond./eva. temperature thermistor (TH5).											
Model	JP1																			
Without TH5	○																			
With TH5	×																			
JP3	Indoor controller board type setting	<table border="1"> <thead> <tr> <th>Indoor controller board type</th> <th>JP3</th> </tr> </thead> <tbody> <tr> <td>For product</td> <td>×</td> </tr> <tr> <td>Service parts</td> <td>○</td> </tr> </tbody> </table>	Indoor controller board type	JP3	For product	×	Service parts	○												
Indoor controller board type	JP3																			
For product	×																			
Service parts	○																			

11-1. ROTATION FUNCTION(AND BACK-UP FUNCTION, 2ND STAGE CUT-IN FUNCTION)

For PKA-RP50FAL2#1,PKA-RP60/71/100FAL#1

11-1-1. Operation

(1) Rotation function (and Back-up function)

• Outline of functions

- Main and sub unit operate alternately according to the interval of rotation setting.
- * Main and sub unit should be set by refrigerant address.(Outdoor Dip switch setting)
 Refrigerant address"00"→ Main unit
 Refrigerant address"01"→ Sub unit
- When error occurs to one unit, another unit will start operation.(Back-up function)

• System constraint

- This function is available only by the grouping control system(INDOOR UNIT : OUTDOOR UNIT=1:1) of 2 refrigerant groups.(Refer to Fig. 1)
- Main indoor unit should be connected for wired remote controller and the transmission line(TB5) for main and sub unit should also be connected. (Refer to Fig. 1)
 (This function cannot be set by wireless remote controller.)
- Set refrigerant address of each unit.(Dip switch on the outdoor unit→Refrigerant address 00/01)

Operation pattern

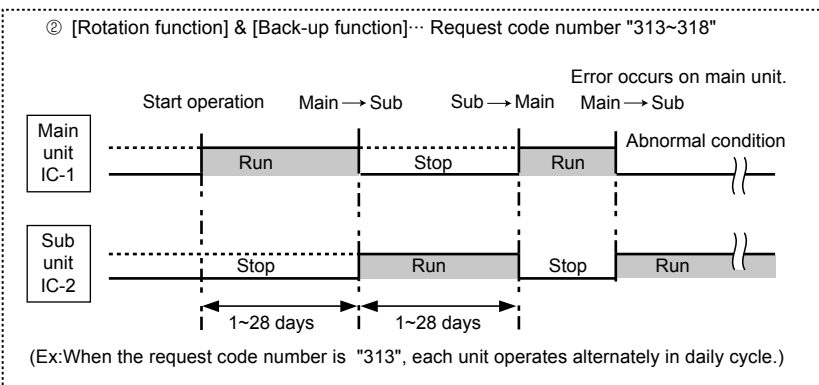
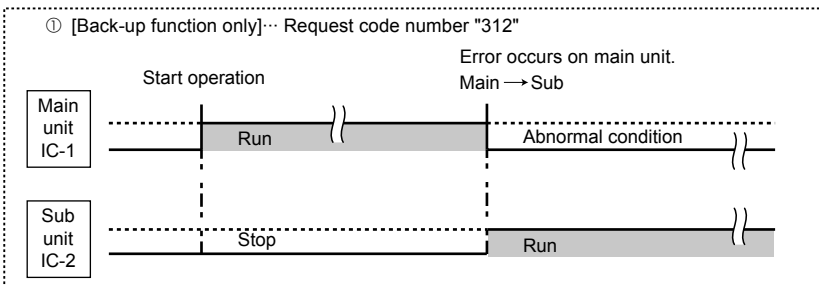

- Note:
- When the unit is restarted to operate after turning off the power or OFF operation, the unit which was operating will start operation.
 - To operate the main unit, refer to the 11-1-2. and set the request code No. which is not the same as the current one, and set again the former request code No.

(2) 2nd stage cut-in function

Outline of functions

- Number of operating units is determined according to the room temperature and set point.
- When room temperature becomes higher than set point, standby unit starts.(2 units operation)
- When room temperature falls below set point -4°C, standby unit stops.(1 unit operation)

System constraint

- This function is available only in rotation operation and back-up function in cooling mode.

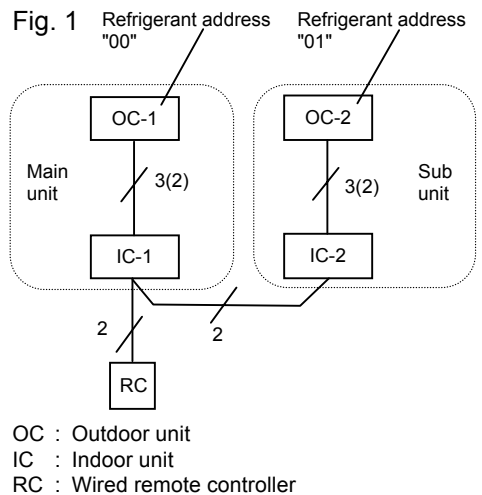
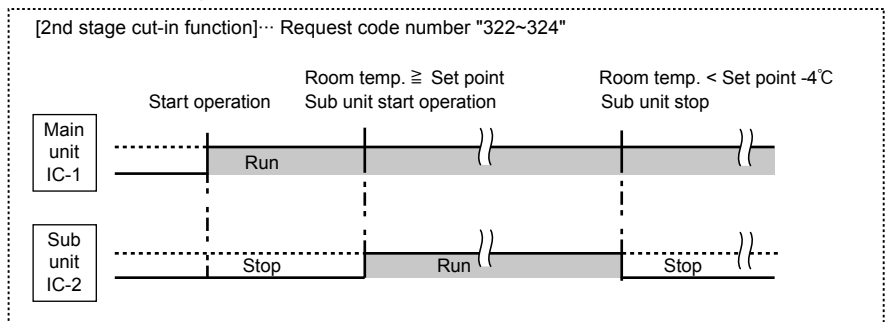

11-1-2. How to set rotation function(Back-up function, 2nd stage cut-in function)

You can set these functions by wired remote controller.(Maintenance monitor)

NOTICE

Both main and sub unit should be set in same setting.

Every time replacing indoor controller board for servicing, the function should be set again.

(1) Request Code List

Rotation setting

Setting No. (Request code)	Setting contents	Initial setting
No.1 (310)	Monitoring the request code of current setting.	
No.2 (311)	Rotation and Back-up OFF (Normal group control operation)	☉
No.3 (312)	Back-up function only	
No.4 (313)	Rotation ON (Alternating interval = 1day) and back up function	
No.5 (314)	Rotation ON (Alternating interval = 3day) and back up function	
No.6 (315)	Rotation ON (Alternating interval = 5day) and back up function	
No.7 (316)	Rotation ON (Alternating interval = 7day) and back up function	
No.8 (317)	Rotation ON (Alternating interval = 14day) and back up function	
No.9 (318)	Rotation ON (Alternating interval = 28day) and back up function	

2nd stage cut-in setting

Setting No. (Request code)	Setting contents	Initial setting
No.1 (320)	Monitoring the request code of current setting.	
No.2 (321)	Cut-in function OFF	☉
No.3 (322)	Cut-in Function ON(Set point = Set temp.+ 4°C(7.2°F))	
No.4 (323)	Cut-in Function ON(Set point = Set temp.+ 6°C(10.8°F))	
No.5 (324)	Cut-in Function ON(Set point = Set temp.+ 8°C(14.4°F))	

(2) Setting method of each function by wired remote controller

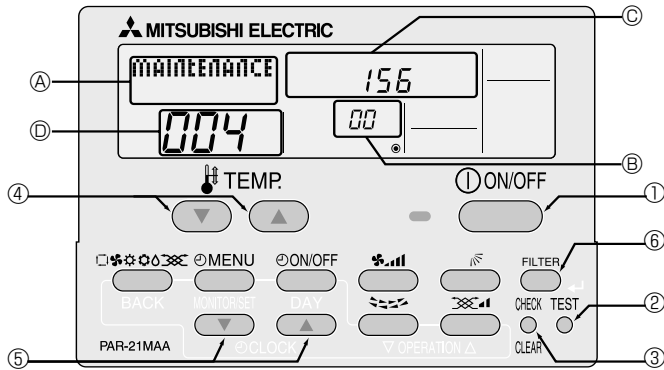

B: Refrigerant address
 C: Data display area
 D: Request code display area

1. Stop operation(①).
2. Press the **TEST** button (②) for 3 seconds so that [Maintenance mode] appears on the screen (A).
 After a while, [00] appears in the refrigerant address number display area.(at B)
3. Press the **CHECK** button (③) for 3 seconds to switch to [Maintenance monitor].
 Note) It is not possible to switch to [Maintenance monitor] during data request in maintenance mode (i.e., while "----" is blinking) since no buttons are operative.

[---] appears on the screen (C) when [Maintenance monitor] is activated.
 (The display (D) now allows you to set a request code No.)

4. Press the [TEMP (▽ and △)] buttons (④) to select the desired refrigerant address.



5. Press the [CLOCK (▽ and △)] buttons (⑤) to set the desired request code No.("311~318", "321~324")
6. Press the **FILTER** button (⑥) to perform function setting.
 If above setting operations are done correctly, "Request code number" will appear in data display area.(C)
 [Example: When the "311" of "Request code number" is set, [311] appears on the screen.(C)]

[Reference]

You can check current "request code number" setting by setting the "request code number"("310" or "320") and pressing the **FILTER** button.(⑥)

[Example: When the current setting is "Setting No.2(Request code 311)", [311] appears on the screen.(C)]

7. To return to normal mode, press the **ON/OFF** button (①).

PKA-RP50FAL2
 PKA-RP60FAL
 PKA-RP60FAL#1
 PKH-P60FALH

PKA-RP50FAL2#1
 PKA-RP71FAL
 PKA-RP71FAL#1
 PKH-P71FALH

PKA-RP100FAL
 PKA-RP100FAL#1
 PKH-P100FALH

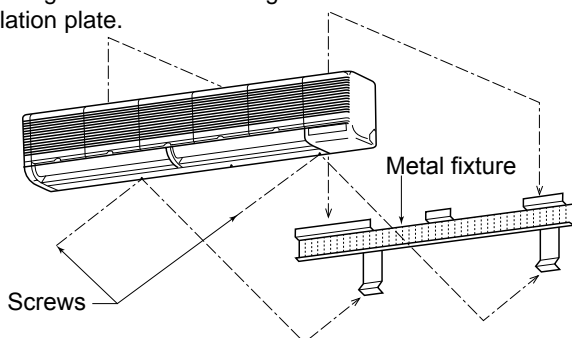
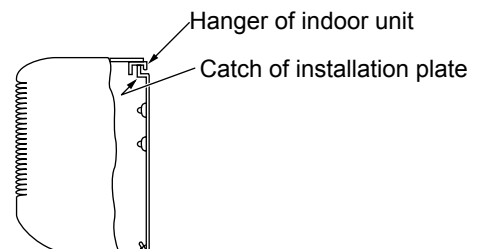
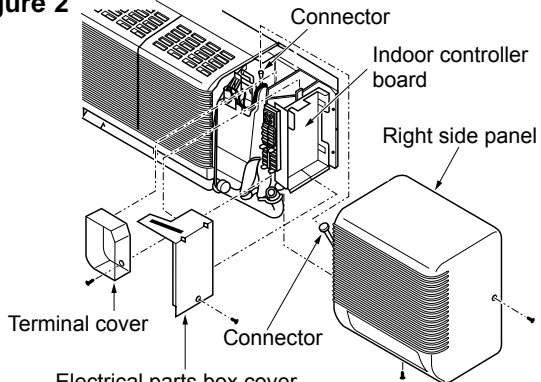
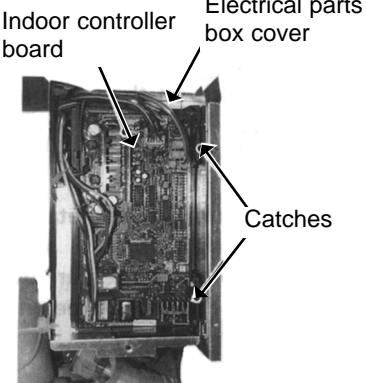
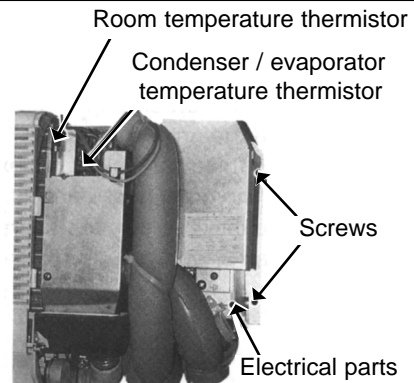
OPERATING PROCEDURE	PHOTOS&ILLUSTRATION
<p>1. Removing the lower side of the indoor unit from the installation plate</p> <p>(1) Remove the 2 screws. Hang the indoor unit hangers to the catches on the installation plate.</p> 	<p>Figure 1</p> 
<p>2. Removing the right side panel</p> <p>(1) Remove the 2 screws of the right side panel: one on the bottom and the other on the upper right-hand side. (2) Disconnect the connector from the adapter case. (3) Sliding the right side panel to the right, pull it out toward you.</p>	<p>Figure 2</p> 
<p>3. Removing the indoor controller board</p> <p>(1) Remove the right side panel. (2) Remove the screw of the electrical parts box cover, and remove the cover. (3) Disconnect the connectors on the indoor controller board. (4) To unhook the catches on the right-hand side of the indoor controller board, pull the left-hand side toward you and lift up the cover to the right. Then the indoor controller board can be removed.</p>	<p>Photo 1</p> 
<p>4. Removing the electrical parts box</p> <p>(1) Remove the right side panel. (2) Remove the screw of the electrical parts box cover, and remove the cover. (3) Remove the room temperature thermistor and the condenser / evaporator temperature thermistor. (4) Disconnect the vane motor connector on the indoor controller board. (5) Remove the 2 screws of the electrical parts box. (6) Disconnect the connector of the heater lead wire connector. (7) Disconnect the connector of the fan motor lead wire. (8) Remove the electrical parts box.</p>	<p>Photo 2</p> 



OPERATING PROCEDURE

PHOTOS&ILLUSTRATION

(9) Remove the screws of the indoor controller board case, and pull out the indoor controller board case.
Then the indoor power board, the fan motor capacitor and the heater relay can be serviced.

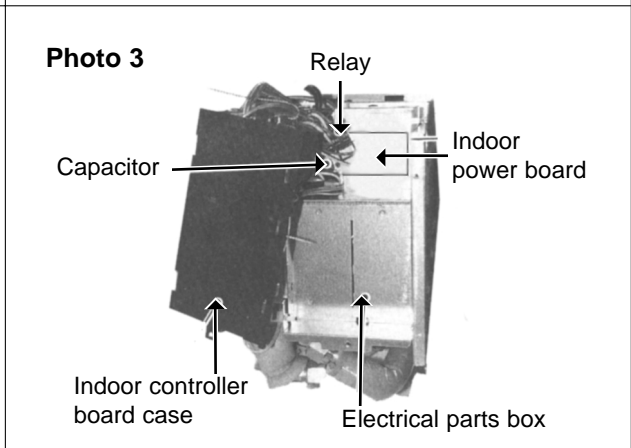

5. Removing the vane motor
(1) Remove the right side panel.
(2) Remove the screw of the electrical parts box cover, and remove the cover.
(3) Remove the 2 screws of the vane motor, and remove the motor from the shaft.
(4) Disconnect the vane motor connector on the indoor controller board.

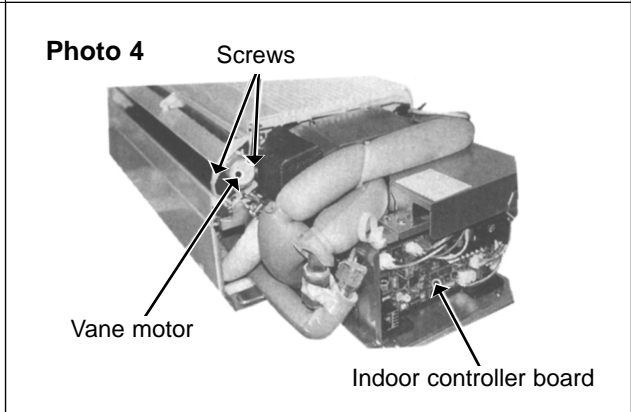

6. Removing the intake grilles
(1) Remove the right side panel.
(2) To remove the left side panel, remove the screw on the bottom and the screw on the upper left-hand side. (See Figure 3.)
1. Press up this side of the left side panel to unhook the catch on the panel from the catch on the unit.
2. Slide the left side panel to the left to remove the panel.
Note: Fix the unit to the metal fixture securely
(3) Remove the air filters.
(4) Hold and press the centre cover to remove.
(5) Remove the screws of the grilles.
(6) Pull the lower side of the grille toward you and slide the upper to the right to remove the grilles.

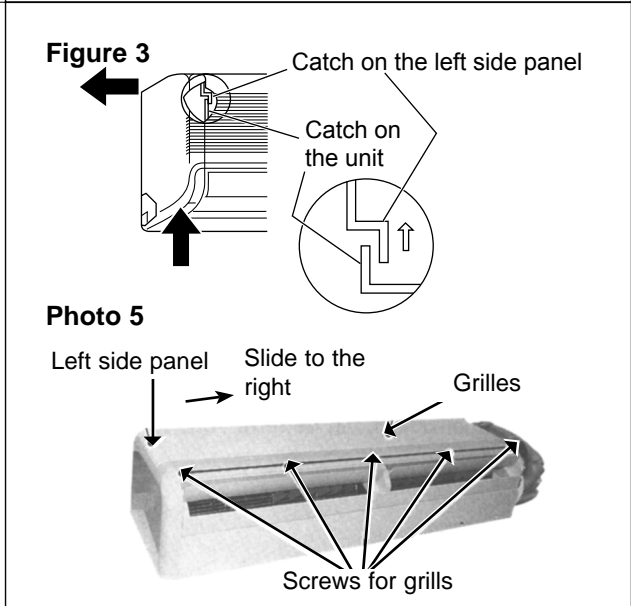

7. Removing the drain pan
(1) Remove the left and right side panels.
(2) Remove the grilles.
(3) Remove the electrical parts box cover.
(4) Loosen the drain hose band to remove.
(5) Remove the 3 screws of the drain pan, and slide the drain pan toward you to remove.

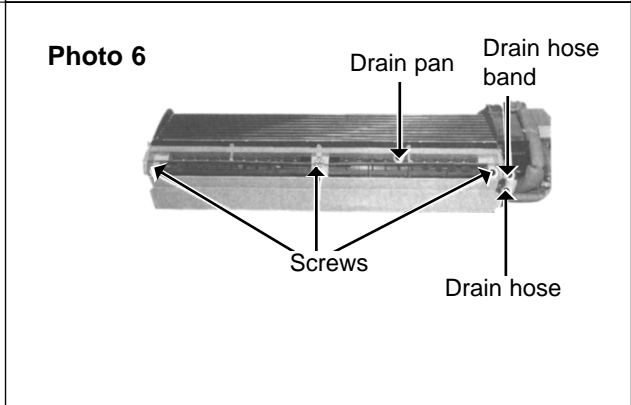

OPERATING PROCEDURE

8. Removing the line flow fan and the fan motor

- (1) Remove the left and right side panels.
- (2) Remove the grilles.
- (3) Remove the electrical parts box.
- (4) Remove the drain pan.
- (5) Loosen the screw that fixes the line flow fan to the fan motor. (See Photo 7.)
- (6) Remove the 4 screws of the motor fixture, and remove the fan motor and the motor fixture at a time (See Photo 8.)
- (7) Remove the screws of the left and right motor supports, and remove the motor supports and the fan motor. (See Photo 9.)
- (8) Remove the 2 screws on the left and right sides of the heat exchanger, and pull the bearing support toward you. (See Photo 11.)
- (9) Remove the screw of the centre support, and remove the support. (See Photo 10.)
- (10) Pull the left-hand side of the heat exchanger toward you, and remove the line flow fan.

Photo 11

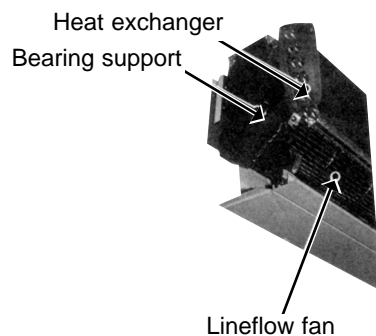

9. Removing the electrical heater. (PKH only)

- (1) Remove the left and right side panels.
- (2) Remove the grills.
- (3) Remove the drain pan.
- (4) Loosen the screw that fixes the line flow fan to the fan motor.(See Photo 7.)
- (5) Remove the screw of the centre support, and remove the support. (See Photo 10.)
- (6) Remove the 2 screws on the left and right sides of the heat exchanger, and pull the bearing support toward you. (See Photo 11.)
- (7) Pull the left-hand side of the heat exchanger toward you, and remove the line flow fan.
- (8) Remove the heater fixing screws (1 screw each on right and left sides), and slide the heater element to the left to remove the heater.

PHOTOS

Photo 7

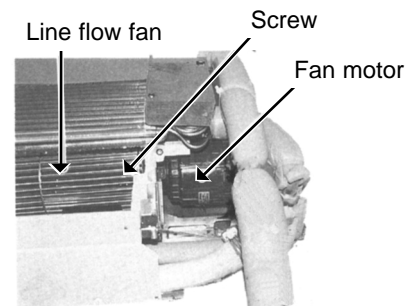

Photo 8

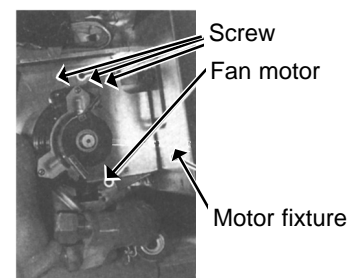

Photo 9

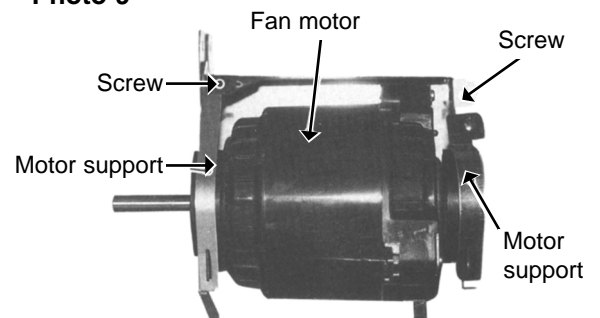

Photo 10

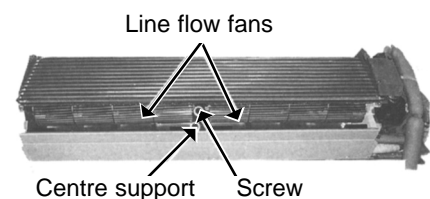
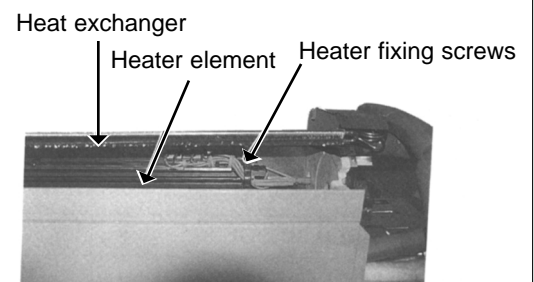

Photo 12



ELECTRICAL PARTS

PKA-RP60FAL

PKH-P60FALH

PKA-RP71FAL

PKH-P71FALH

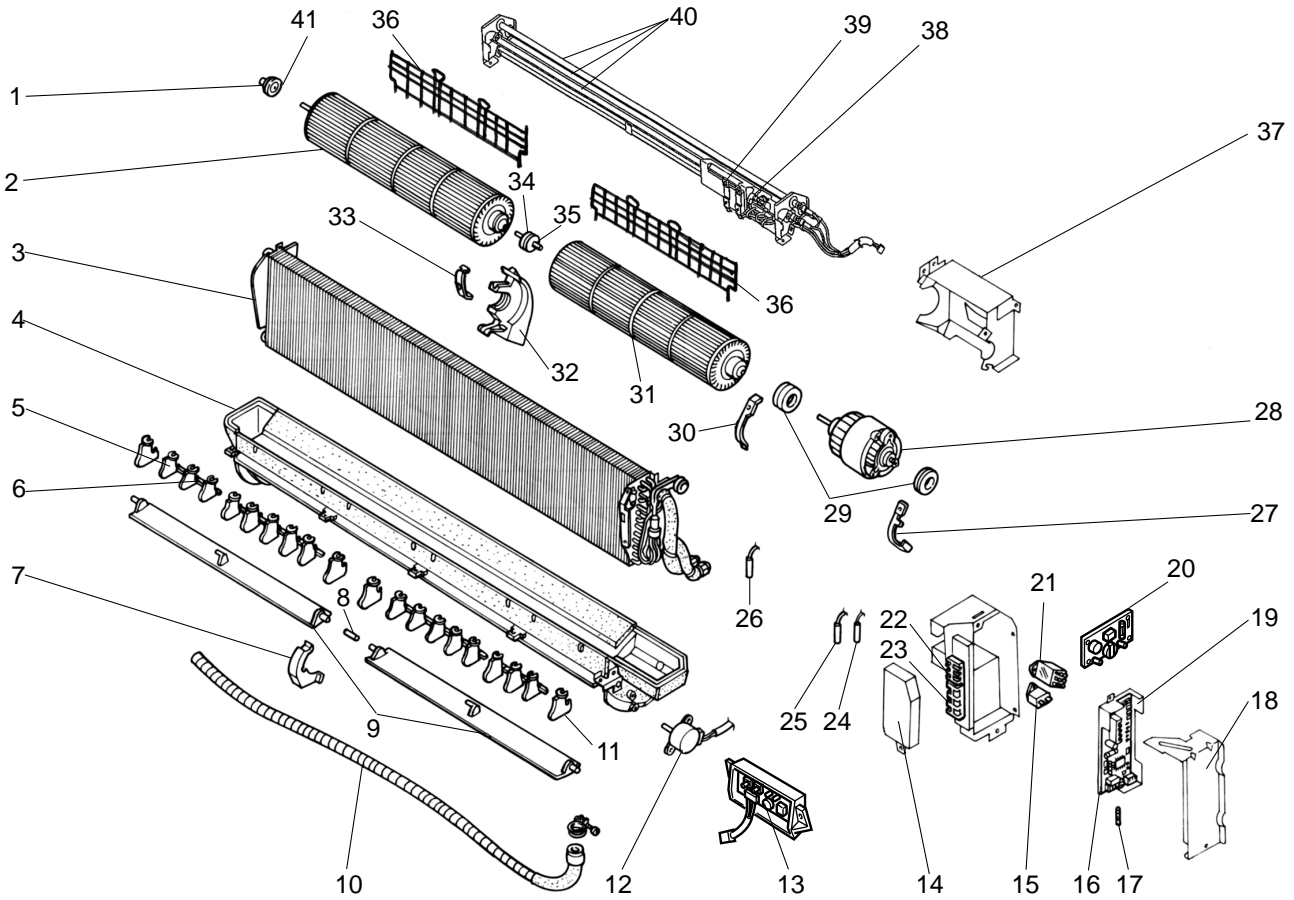

No.	Part No.	Part Name	Specification	Q'ty/set				Remarks (Drawing No.)	Wiring Diagram Symbol	Recom- mended Q'ty
				PKH-P-FALH		PKA-RP-FAL				
				60	71	60	71			
1	R01 Z61 102	BEARING MOUNT		1	1	1	1			
2	R01 12G 114	LEFT LINEFLOW FAN		1	1					
	R01 G13 114	LEFT LINEFLOW FAN				1	1			
3	T7W E57 480	HEAT EXCHANGER				1				
	R01 E61 480	HEAT EXCHANGER		1						
	R01 E62 480	HEAT EXCHANGER			1		1			
4	T7W E13 529	DRAIN PAN		1	1	1	1			
5	—	GUIDE VANE		16	16	16	16	(BG25J821H01)		
6	—	ARM		3	3	3	3	(BG25H301H02)		
7	R01 12G 621	CENTER COVER		1	1	1	1			
8	R01 12G 063	JOINT SHAFT		1	1	1	1			
9	R01 12G 002	AUTO VANE		2	2	2	2			
10	R01 KV5 527	DRAIN HOSE		1	1	1	1			
11	—	GUIDE VANE		4	4	4	4	(BG25J821H02)		
12	R01 E05 223	VANE MOTER		1	1	1	1		MV	
13	R01 E06 317	WIRELESS ADAPTER CONTROLLER BOARD		1	1	1	1		W.B	
14	—	TERMINAL COVER		1	1	1	1	(BG02J608H07)		
15	R01 588 255	CAPACITOR	2.0 μ F 440V	1	1	1	1		C	
16	T7W E40 310	INDOOR CONTROLLER BOARD		1	1	1	1		I.B	

Continued to the next page.

From the previous page.

Part number that is circled is not shown in the figure.

No.	Part No.	Part Name	Specification	Q'ty/set				Remarks (Drawing No.)	Wiring Diagram Symbol	Recom- mended Q'ty
				PKH-P		PKA-RP				
				60 FALH	71 FALH	60 FAL	71 FAL			
17	R01 E02 239	FUSE	250V 6.3A	1	1	1	1		FUSE	
18	—	CONTROLLER COVER		1	1	1	1	(BG02A648G03)		
19	—	CONTROLLER CASE		1	1	1	1	(BG25J080H02)		
20	R01 E02 313	INDOOR POWER BOARD		1	1	1	1		P.B	
21	R01 71G 215	HEATER CONTACTOR	JC-1A DC12V	1	1				88H	
22	T7W E23 716	TERMINAL BLOCK	3P(S1, S2, S3)	1	1	1	1		TB4	
23	T7W A14 716	TERMINAL BLOCK	3P(L,N,⊕)	1	1				TB2	
24	T7W E12 202	ROOM TEMPERATURE THERMISTOR		1	1	1	1		TH1	
25	R01 E34 202	CONDENSER / EVAPORATOR TEMPERATURE THERMISTOR		1	1	1	1		TH5	
26	R01 E02 202	PIPE TEMPERATURE THERMISTOR		1	1	1	1		TH2	
27	—	MOTOR BAND		1	1	1	1	(BG02H065H01)		
28	R01 12G 220	FAN MOTOR	PN4S40-K	1	1	1	1		MF	
29	R01 12G 105	RUBBER MOUNT		2	2	2	2			
30	—	MOTOR BAND		1	1	1	1	(BG02H178H01)		
31	R01 12G 115	RIGHT LINEFLOW FAN		1	1					
	R01 13G 115	RIGHT LINEFLOW FAN				1	1			
32	—	CENTER SUPPORT		1	1	1	1	(BG00R259G07)		
33	—	BEARING BAND		1	1	1	1	(BG02L462H02)		
34	R01 KV5 102	BEARING MOUNT		1	1	1	1			
35	R01 12G 103	SLEEVE BEARING		1	1	1	1			
36	T7W B02 675	FAN GUARD		2	2	2	2			
37	—	MOTOR LEG		1	1	1	1	(BG02A534H16)		
38	R01 230 700	HEATER THERMAL SWITCH	70°C OFF 50°C ON	1	1				26H	
39	R01 12G 706	THERMAL FUSE	117°C 10A 250V	1	1				FS1,2	
40	T7W 587 300	HEATER	240V 700W	3	3				H1	
41	R01 005 103	SLEEVE BEARING		1	1	1	1			
④2	R01 20J 303	INSULATOR		1	1					

ELECTRICAL PARTS
PKA-RP100FAL PKH-P100FALH

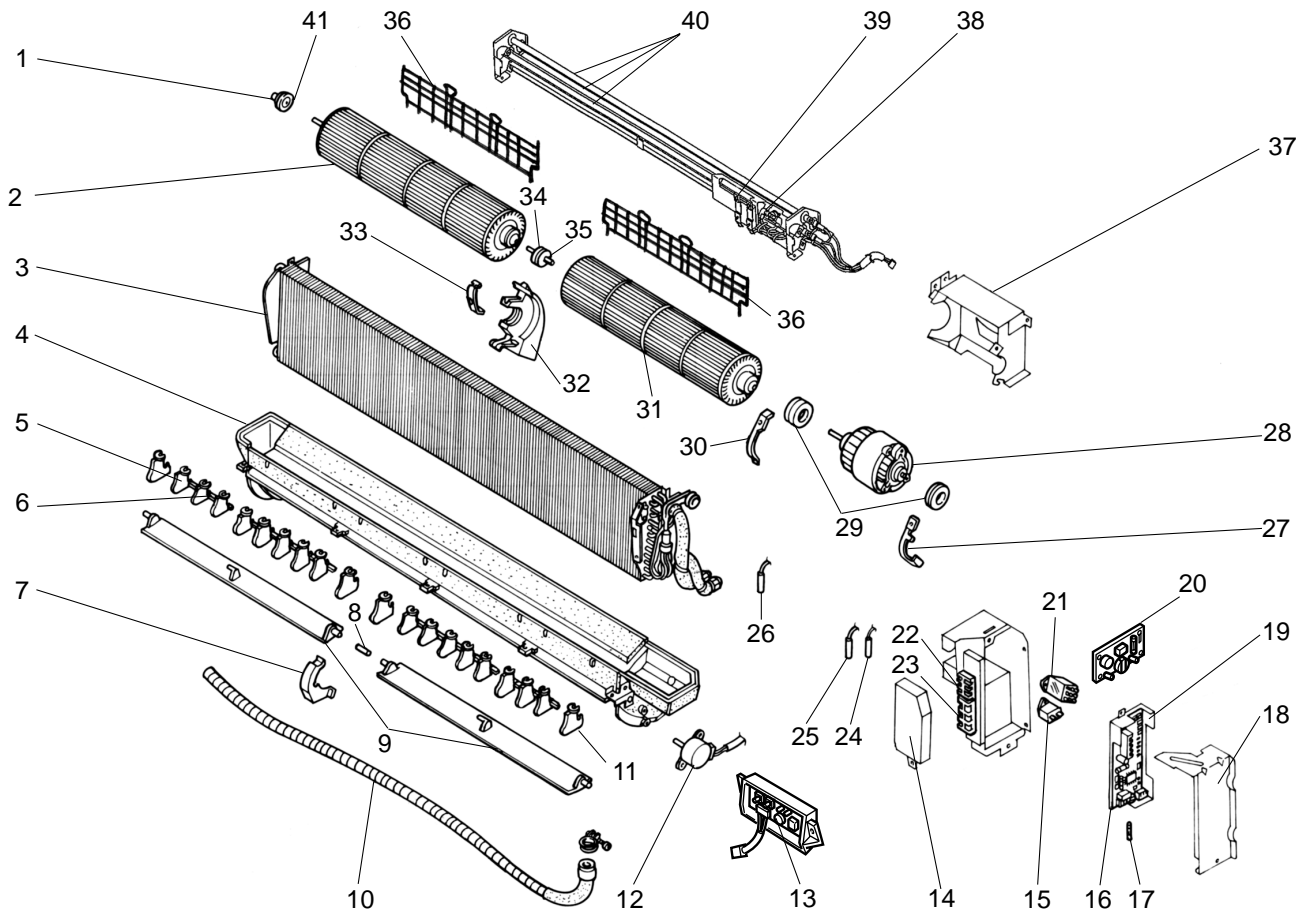

No.	Part No.	Part Name	Specification	Q'ty/set		Remarks (Drawing No.)	Wiring Diagram Symbol	Recom- mended Q'ty
				PKH - P 100FALH	PKA - RP 100FAL			
1	R01 Z61 102	BEARING MOUNT		1	1			
2	R01 16G 114	LEFT LINEFLOW FAN		1				
	R01 17G 114	LEFT LINEFLOW FAN			1			
3	T7W E22 480	HEAT EXCHANGER		1				
	T7W E58 480	HEAT EXCHANGER			1			
4	T7W E14 529	DRAIN PAN		1	1			
5	—	GUIDE VANE		22	22	(BG25J821H01)		
6	—	ARM		4	4	(BG25H301H02)		
7	R01 12G 621	CENTER COVER		1	1			
8	R01 12G 063	JOINT SHAFT		1	1			
9	R01 16G 002	AUTO VANE		2	2			
10	R01 KV5 527	DRAIN HOSE		1	1			
11	—	GUIDE VANE		4	4	(BG25J821H02)		
12	R01 E05 223	VANE MOTER		1	1		MV	
13	R01 E03 317	WIRELESS ADAPTER CONTROLLER BOARD		1	1		W.B	
14	—	TERMINAL COVER		1	1	(BG02J608H07)		
15	R01 576 255	CAPACITOR	3.0 μ F 440V	1	1		C	
16	T7W E40 310	INDOOR CONTROLLER BOARD		1	1		I.B	

Continued to the next page.

From the previous page.

Part number that is circled is not shown in the figure.

No.	Part No.	Part Name	Specification	Q'ty/set		Remarks (Drawing No.)	Wiring Diagram Symbol	Recom- mended Q'ty
				PKH-P	PKA-RP			
				100FALH	100FAL			
17	R01 E02 239	FUSE	250V 6.3A	1	1		FUSE	
18	—	CONTROLLER COVER		1	1	(BG02A648G03)		
19	—	CONTROLLER CASE		1	1	(BG25J080H02)		
20	R01 E02 313	INDOOR POWER BOARD		1	1		P.B	
21	R01 71G 215	HEATER CONTACTOR	JC-1A DC12V	1			88H	
22	T7W E23 716	TERMINAL BLOCK	3P(S1, S2, S3)	1	1		TB4	
23	T7W A14 716	TERMINAL BLOCK	3P(L, N, ⊕)	1			TB2	
24	T7W E12 202	ROOM TEMPERATURE THERMISTOR		1	1		TH1	
25	R01 E34 202	CONDENSER / EVAPORATOR TEMPERATURE THERMISTOR		1	1		TH5	
26	R01 E02 202	PIPE TEMPERATURE THERMISTOR		1	1		TH2	
27	—	MOTOR BAND		1	1	(BG02H065H01)		
28	T7W 571 762	FAN MOTOR	PN4S70-K	1	1		MF	
29	R01 16G 105	RUBBER MOUNT		2	2			
30	—	MOTOR BAND		1	1	(BG02H178H01)		
31	R01 16G 115	RIGHT LINEFLOW FAN		1				
	R01 17G 115	RIGHT LINEFLOW FAN			1			
32	—	CENTER SUPPORT		1	1	(BG00R259G07)		
33	—	BEARING BAND		1	1	(BG02L462H02)		
34	R01 KV5 102	BEARING MOUNT		1	1			
35	R01 12G 103	SLEEVE BEARING		1	1			
36	T7W B03 675	FAN GUARD		2	2			
37	—	MOTOR LEG		1	1	(BG02A534H17)		
38	R01 230 700	HEATER THERMAL SWITCH	70°C OFF 50°C ON	1			26H	
39	T7W 589 706	THERMAL FUSE	117°C 16A 250V	1			FS1,2	
40	T7W 589 300	HEATER	240V 800W	3			H1	
41	R01 005 103	SLEEVE BEARING		1	1			
④2	R01 20J 303	INSULATOR		1				

STRUCTURAL PARTS

PKA-RP60FAL PKH-P60FALH
 PKA-RP71FAL PKH-P71FALH

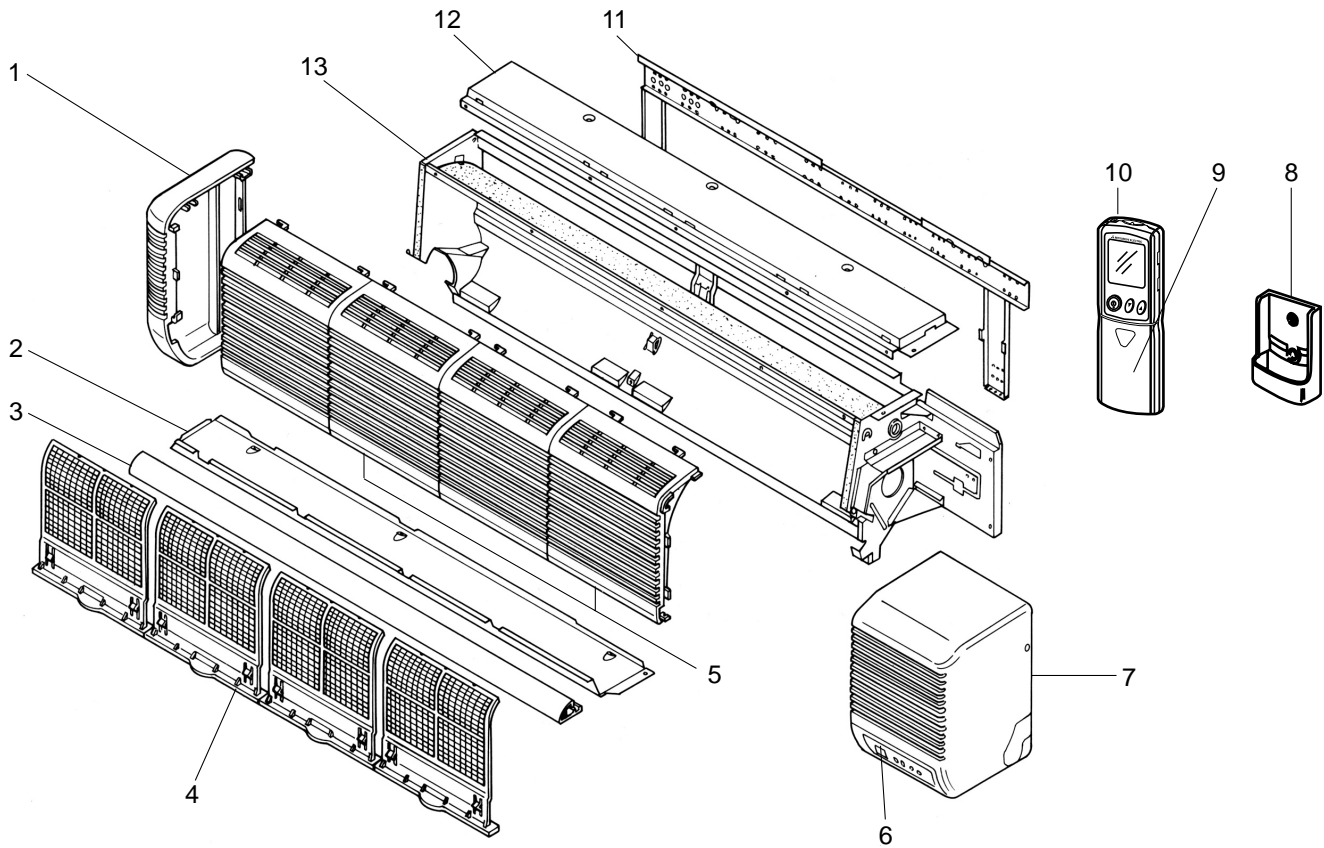

Part number that is circled is not shown in the figure.

No.	Part No.	Part Name	Specifications	Q'ty/set		Remarks (Drawing No.)	Wiring Diagram Symbol	Recom- mended Q'ty
				PKA- RP60FAL RP71FAL	PKH- P60FALH P71FALH			
1	R01 12G 662	LEFT SIDE PANEL		1	1			
2	R01 E01 812	UNDER PLATE		1	1			
3	R01 E00 811	NOSE		1	1			
4	R01 A17 500	AIR FILTER		4	4			
5	R01 12G 691	INTAKE GRILLE		2	2			
6	R01 24K 658	RECEIVER		1	1		RU	
7	T7W E05 661	RIGHT SIDE PANEL		1	1			
8	R01 E00 075	WIRELESS REMOTE CONTROLLER HOLDER		1	1			
9	R01 E01 049	WIRELESS REMOTE CONTROLLER DOOR		1	1			
10	T7W E06 714	WIRELESS REMOTE CONTROLLER		1	1			
11	R01 12G 808	BACK PLATE		1	1			
12	R01 E01 641	TOP PLATE		1	1			
13	—	BOX ASSEMBLY		1		(RG00A734GG9)		
	—	BOX ASSEMBLY			1	(RG00A734GH1)		
14	R01 12G 523	DRAIN SOCKET		1	1			

STRUCTURAL PARTS PKA-RP100FAL PKH-P100FALH

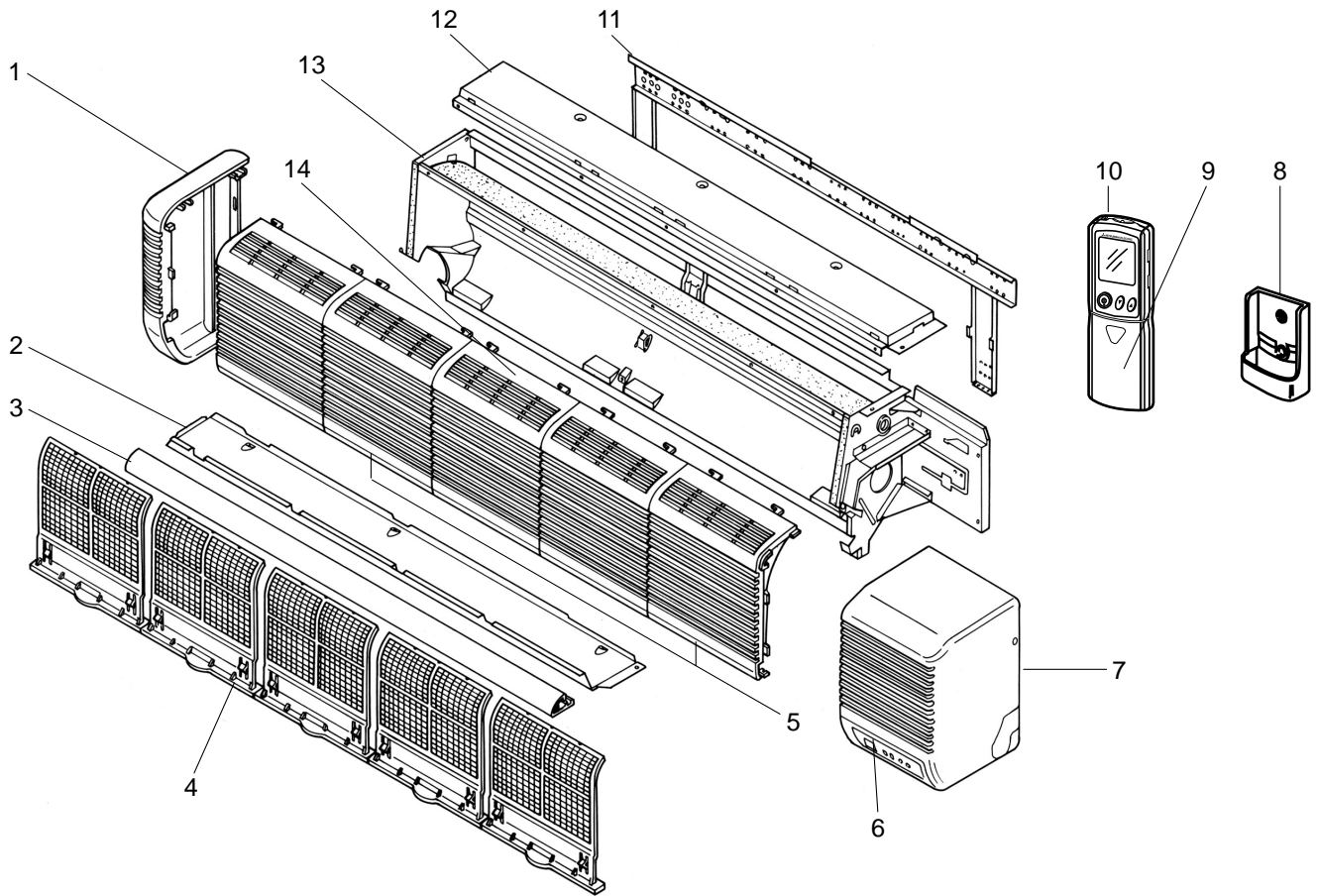

Part number that is circled is not shown in the figure.

No.	Part No.	Part Name	Specification	Q'ty/set		Remarks (Drawing No.)	Wiring Diagram Symbol	Recom- mended Q'ty
				PKA-	PKH-			
				RP100FAL	P100FALH			
1	R01 12G 662	LEFT SIDE PANEL		1	1			
2	R01 E00 812	UNDER PLATE		1	1			
3	R01 E01 811	NOSE		1	1			
4	R01 A17 500	AIR FILTER		5	5			
5	R01 12G 691	INTAKE GRILLE		2	2			
6	R01 24K 658	RECEIVER		1	1		RU	
7	T7W E05 661	RIGHT SIDE PANEL		1	1			
8	R01 E00 075	WIRELESS REMOTE CONTROLLER HOLDER		1	1			
9	R01 E01 049	WIRELESS REMOTE CONTROLLER DOOR		1	1			
10	T7W E06 714	WIRELESS REMOTE CONTROLLER		1	1			
11	R01 16G 808	BACK PLATE		1	1			
12	R01 E00 641	TOP PLATE		1	1			
13	—	BOX ASSEMBLY		1		(RG00A734GH0)		
	—	BOX ASSEMBLY			1	(RG00A734GH2)		
14	R01 16G 692	INTAKE GRILLE		1	1			
⑮	R01 12G 523	DRAIN SOCKET		1	1			

ELECTRICAL PARTS

PKA-RP50FAL2
PKA-RP50FAL2#1
PKH-P60FALH

PKA-RP60FAL
PKA-RP60FAL#1
PKH-P71FALH

PKA-RP71FAL
PKA-RP71FAL#1

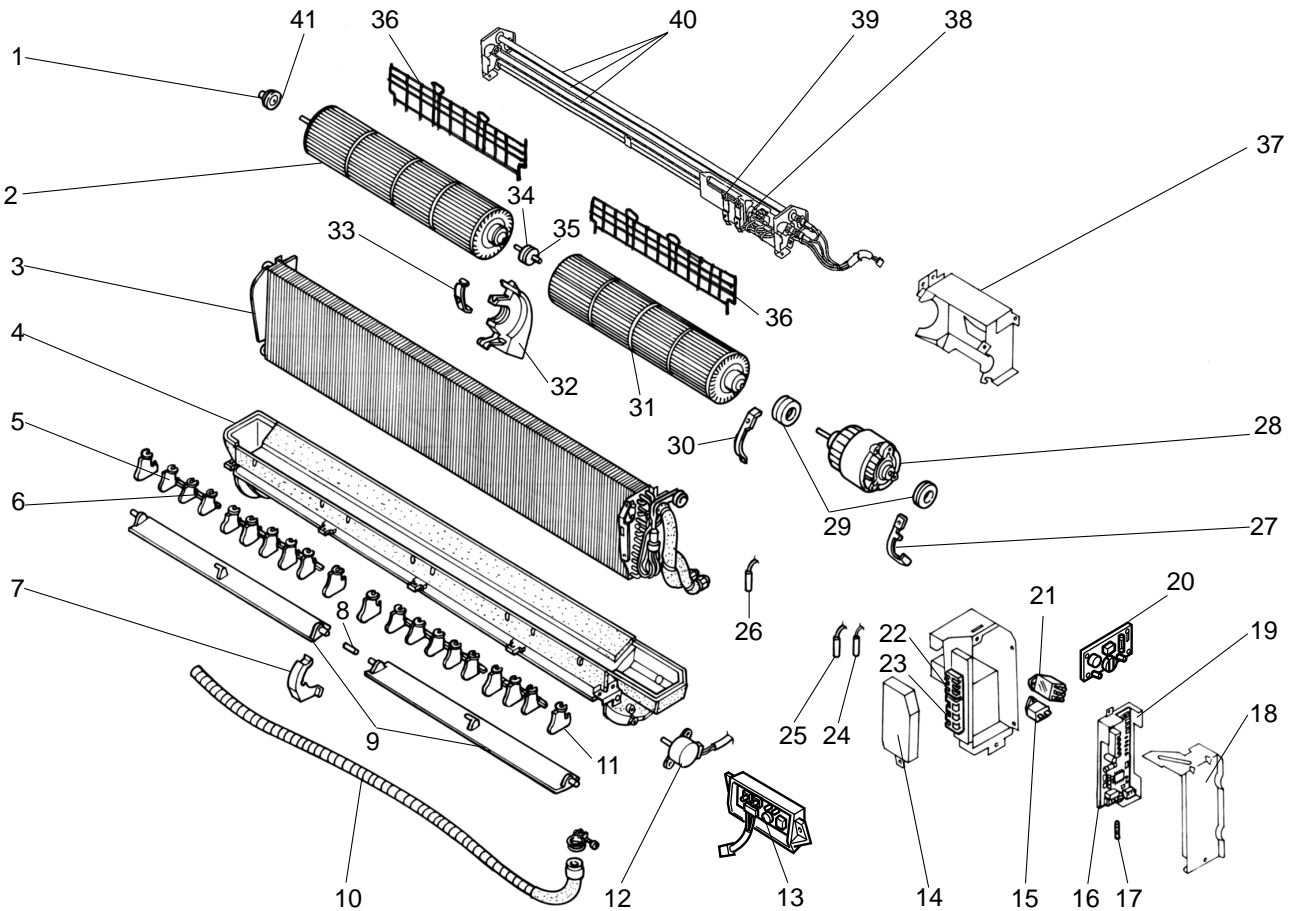

No.	RoHS	Part No.	Part Name	Specification	Q'ty/set					Remarks (Drawing No.)	Wiring Diagram Symbol	recom- mended Q'ty		
					PKH-P		PKA-RP							
					60 FALH	71 FALH	50 FAL2	60 FAL	71 FAL				50 FAL2#1	60 FAL#1
1	G	R01 Z61 102	BEARING MOUNT		1	1	1	1	1	1				
2	G	R01 18G 114	LEFT LINEFLOW FAN		1	1								
	G	R01 E23 114	LEFT LINEFLOW FAN				1	1	1	1	1			
3	G	T7W H39 480	HEART EXCHANGER				1			1				
	G	R01 K49 480	HEART EXCHANGER		1						1			
	G	R01 K50 480	HEART EXCHANGER			1						1		
4	G	T7W E24 529	DRAIN PAN		1	1	1	1	1	1	1	1		
5	G	—	GUIDE VANE		16	16	16	16	16	16	16	16	(BG25J821G01)	
6	G	—	ARM		3	3	3	3	3	3	3	3	(BG25H301G01)	
7	G	R01 14G 621	CENTER COVER		1	1	1	1	1	1	1	1		
8	G	R01 13G 063	JOINT SHAFT		1	1	1	1	1	1	1	1		
9	G	R01 18G 002	AUTO VANE		2	2	2	2	2	2	2	2		
10	G	R01 E04 527	DRAIN HOSE		1	1	1	1	1	1	1	1		
11	G	—	GUIDE VANE		4	4	4	4	4	4	4	4	(BG25J821G02)	
12	G	R01 E15 223	VANE MOTER		1	1	1	1	1	1	1	1		MV
13	G	R01 E06 317	WIRELESS ADAPTER CONTROLLER BOARD		1	1	1	1	1	1	1	1		W.B
14	G	—	TERMINAL COVER		1	1	1	1	1	1	1	1	(BG02J608H07)	
15	G	R01 E13 255	CAPACITOR	2.0μF 440V	1	1	1	1	1	1	1	1		C
16	G	T7W E50 310	INDOOR CONTROLLER BOARD		1	1	1	1	1					I.B
	G	T7W E73 310	INDOOR CONTROLLER BOARD							1	1	1		I.B

Continued to the next page.

From the previous page.

Part number that is circled is not shown in the figure.

No.	RoHS	Part No.	Part Name	Specification	Q'ty/set					Remarks (Drawing No.)	Wiring Diagram Symbol	Recom- mended Q'ty
					PKH-P		PKA-RP					
					60FALH	71FALH	50FAL2 50FAL2#1	60FAL 60FAL#1	71FAL 71FAL#1			
17	G	R01 E06 239	FUSE	250V 6.3A	1	1	1	1	1		FUSE	
18	G	—	CONTROLLER COVER		1	1	1	1	1	(BG02A648G03)		
19	G	—	CONTROLLER CASE		1	1	1	1	1	(BG25J080H02)		
20	G	R01 E38 313	INDOOR POWER BOARD		1	1	1	1	1		P.B	
21	G	R01 E03 215	HEATER CONTACTOR	JC-1A DC12V	1	1					88H	
22	G	R01 E20 246	TERMINAL BLOCK	3P(S1, S2, S3)	1	1	1	1	1		TB4	
23	G	T7W E32 716	TERMINAL BLOCK	3P(L,N,⊕)	1	1					TB2	
24	G	R01 H05 202	ROOM TEMPERATURE THERMISTOR		1	1	1	1	1		TH1	
25	G	R01 H06 202	CONDENSER / EVAPORATOR TEMPERATURE THERMISTOR		1	1	1	1	1		TH5	
26	G	R01 H07 202	PIPE TEMPERATURE THERMISTOR		1	1	1	1	1		TH2	
27	G	—	MOTOR BAND		1	1	1	1	1	(BG02H065H01)		
28	G	R01 13G 220	FAN MOTOR	PN4S40-K	1	1	1	1	1		MF	
29	G	R01 12G 105	RUBBER MOUNT		2	2	2	2	2			
30	G	—	MOTOR BAND		1	1	1	1	1	(BG02H178H01)		
31	G	R01 18G 115	RIGHT LINEFLOW FAN		1	1						
	G	R01 E04 115	RIGHT LINEFLOW FAN				1	1	1			
32	G	—	CENTER SUPPORT		1	1	1	1	1	(BG00R259G07)		
33	G	—	BEARING BAND		1	1	1	1	1	(BG02L462H02)		
34	G	R01 KV5 102	BEARING MOUNT		1	1	1	1	1			
35	G	R01 E03 103	SLEEVE BEARING		1	1	1	1	1			
36	G	T7W E15 675	FAN GUARD		2	2	2	2	2			
37	G	—	MOTOR LEG		1	1	1	1	1	(BG02A534H16)		
38	G	R01 E06 700	HEATER THERMAL SWITCH	70°C OFF 50°C ON	1	1					26H	
39	G	R01 13G 706	THERMAL FUSE	117°C 10A 250V	1	1					FS1,2	
40	G	T7W E17 300	HEATER	240V 700W	3	3					H1	
41	G	R01 E04 103	SLEEVE BEARING		1	1	1	1	1			
④2	G	R01 31J 303	INSULATOR		1	1						

ELECTRICAL PARTS
PKA-RP100FAL

PKA-RP100FAL#1

PKH-P100FALH

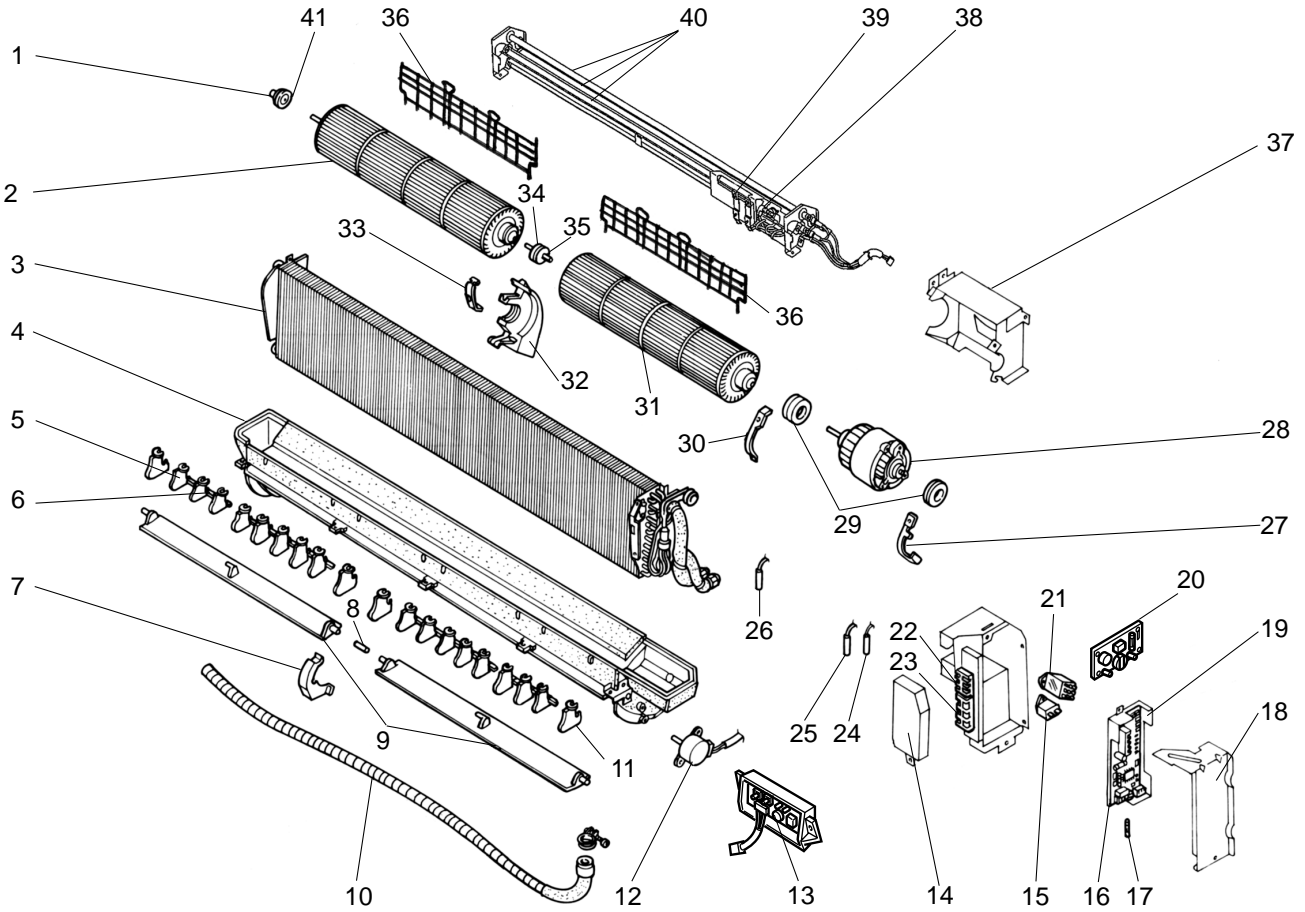

No.	ROHS	Part No.	Part Name	Specification	Q'ty/set			Remarks (Drawing No.)	Wiring Diagram Symbol	recom- mended Q'ty
					PKH-P	PKA-RP				
					100FALH	100FAL	100FAL#1			
1	G	R01 Z61 102	BEARING MOUNT		1	1	1			
2	G	R01 19G 114	LEFT LINEFLOW FAN		1					
	G	R01 E24 114	LEFT LINEFLOW FAN			1	1			
3	G	T7W H35 480	HEART EXCHANGER		1					
	G	T7W H38 480	HEART EXCHANGER			1	1			
4	G	T7W E25 529	DRAIN PAN		1	1	1			
5	G	—	GUIDE VANE		22	22	22	(BG25J821G01)		
6	G	—	ARM		4	4	4	(BG25H301G01)		
7	G	R01 14G 621	CENTER COVER		1	1	1			
8	G	R01 13G 063	JOINT SHAFT		1	1	1			
9	G	R01 19G 002	AUTO VANE		2	2	2			
10	G	R01 E04 527	DRAIN HOSE		1	1	1			
11	G	—	GUIDE VANE		4	4	4	(BG25J821G02)		
12	G	R01 E15 223	VANE MOTER		1	1	1		MV	
13	G	R01 E06 317	WIRELESS ADAPTER CONTROLLER BOARD		1	1	1		W.B	
14	G	—	TERMINAL COVER		1	1	1	(BG02J608H07)		
15	G	R01 E12 255	CAPACITOR	3.0 μ F 440V	1	1	1		C	
16	G	T7W E50 310	INDOOR CONTROLLER BOARD		1	1			I.B	
	G	T7W E73 310	INDOOR CONTROLLER BOARD				1		I.B	

Continued to the next page.

From the previous page.

Part number that is circled is not shown in the figure.

No.	RoHS	Part No.	Part Name	Specification	Q'ty/set			Remarks (Drawing No.)	Wiring Diagram Symbol	recom- mended Q'ty
					PKH-P	PKA-RP				
					100FALH	100FAL	100FAL#1			
17	G	R01 E06 239	FUSE	250V 6.3A	1	1	1		FUSE	
18	G	—	CONTROLLER COVER		1	1	1	(BG02A648G03)		
19	G	—	CONTROLLER CASE		1	1	1	(BG25J080H02)		
20	G	R01 E38 313	INDOOR POWER BOARD		1	1	1		P.B	
21	G	R01 E03 215	HEARTER CONTACTOR	JC-1A DC12V	1				88H	
22	G	R01 E20 246	TERMINAL BLOCK	3P(S1, S2, S3)	1	1	1		TB4	
23	G	T7W E32 716	TERMINAL BLOCK	3P(L, N, ⊕)	1				TB2	
24	G	R01 H07 202	ROOM TEMPERATURE THERMISTOR		1	1	1		TH1	
25	G	R01 H05 202	CONDENSER/ EVAPORATOR TEMPERATURE THERMISTOR		1	1	1		TH5	
26	G	R01 H06 202	PIPE TEMPERATURE THERMISTOR		1	1	1		TH2	
27	G	—	MOTOR BAND		1	1	1	(BG02H065H01)		
28	G	T7W E24 762	FAN MOTOR	PN4S70-K	1	1	1		MF	
29	G	R01 16G 105	RUBBER MOUNT		2	2	2			
30	G	—	MOTOR BAND		1	1	1	(BG02H178H01)		
31	G	R01 19G 115	RIGHT LINEFLOW FAN		1	1				
	G	R01 E05 115	RIGHT LINEFLOW FAN				1			
32	G	—	CENTER SUPPORT		1	1	1	(BG00R259G07)		
33	G	—	BEARING BAND		1	1	1	(BG02L462H02)		
34	G	R01 KV5 102	BEARING MOUNT		1	1	1			
35	G	R01 E03 103	SLEEVE BEARING		1	1	1			
36	G	T7W E16 675	FAN GUARD		2	2	2			
37		—	MOTOR LEG		1	1	1	(BG02A534H17)		
38	G	R01 E06 700	HEATER THERMAL SWITCH	70°C OFF 50°C ON	1				26H	
39	G	T7W 11G 706	THERMAL FUSE	117°C 16A 250V	1				FS1, 2	
40	G	T7W E16 300	HEATER	240V 800W	3				H1	
41	G	R01 E04 103	SLEEVE BEARING		1	1	1			
④2	G	R01 31J 303	INSULATOR		1					

STRUCTURAL PARTS

PKA-RP50FAL2
PKA-RP50FAL2#1
PKH-P60FALH

PKA-RP60FAL
PKA-RP60FAL#1
PKH-P71FALH

PKA-RP71FAL
PKA-RP71FAL#1

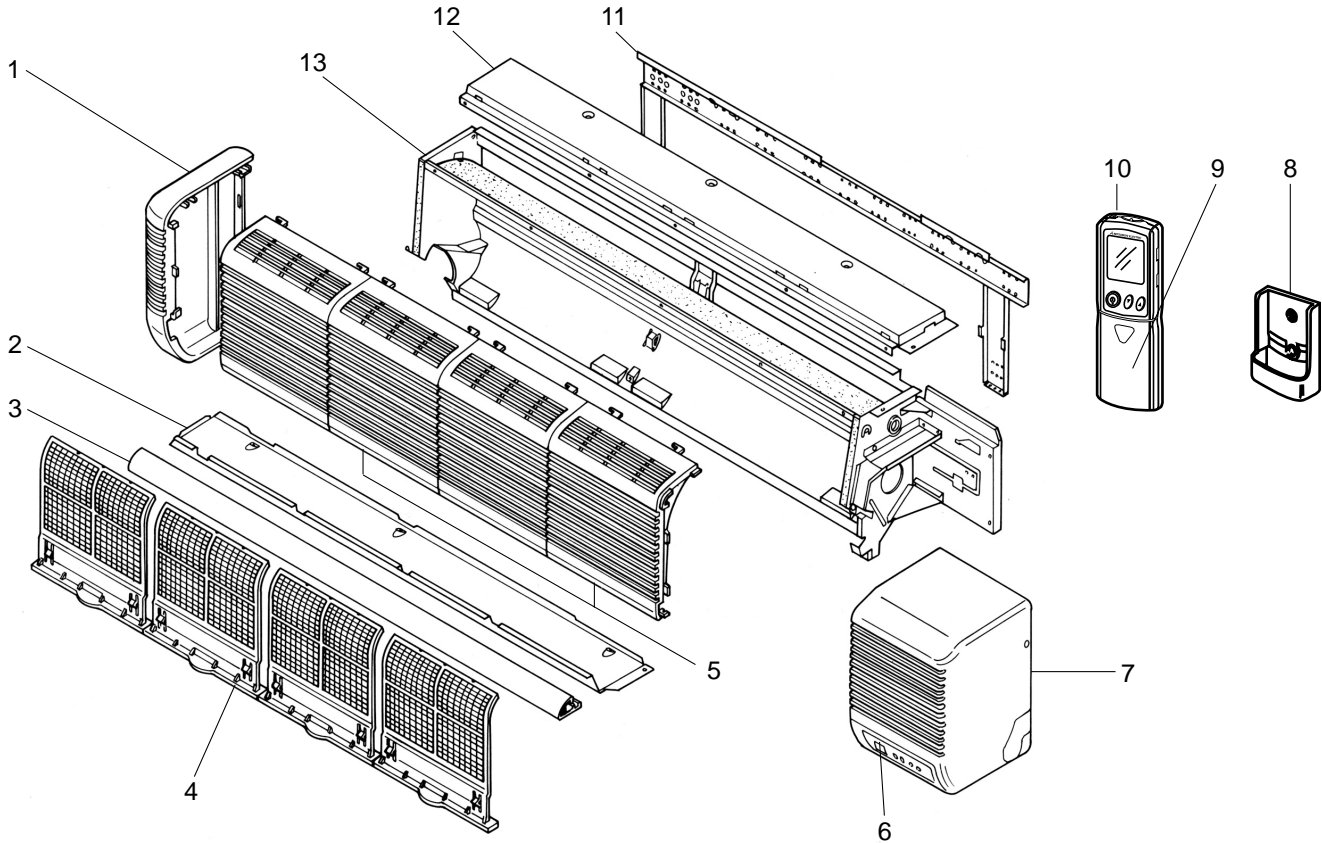

Part number that is circled is not shown in the figure.

No.	RoHS	Part No.	Part Name	Specifications	Q'ty/set			Remarks (Drawing No.)	Wiring Diagram Symbol	Recom- mended Q'ty
					PKA-RP		PKH-P			
					50FAL2 60FAL 71FAL	50FAL2#1 60FAL#1 71FAL#1	60FALH 71FALH			
1	G	R01 14G 662	LEFT SIDE PANEL		1	1	1			
2	G	R01 E02 812	UNDER PLATE		1	1	1			
3	G	R01 E00 811	NOSE		1	1	1			
4	G	R01 A17 500	AIR FILTER		4	4	4			
5	G	R01 17G 691	INTAKE GRILLE		2	2	2			
6	G	R01 E18 658	RECEIVER		1	1	1		RU	
7	G	T7W E18 661	RIGHT SIDE PANEL		1	1	1			
8	G	R01 E00 075	WIRELESS REMOTE CONTROLLER HOLDER		1	1	1			
9	G	R01 E03 049	WIRELESS REMOTE CONTROLLER DOOR		1	1	1			
10	G	T7W E10 714	WIRELESS REMOTE CONTROLLER		1	1	1			
11	G	R01 E03 808	BACK PLATE		1	1	1			
12	G	R01 E19 641	TOP PLATE		1	1	1			
13	G	—	BOX ASSEMBLY		1	1		(RG00A734GP5)		
	G	—	BOX ASSEMBLY				1	(RG00A734GP7)		
14	G	R01 E02 523	DRAIN SOCKET		1	1	1			

STRUCTURAL PARTS

PKA-RP100FAL PKA-RP100FAL#1 PKH-P100FALH

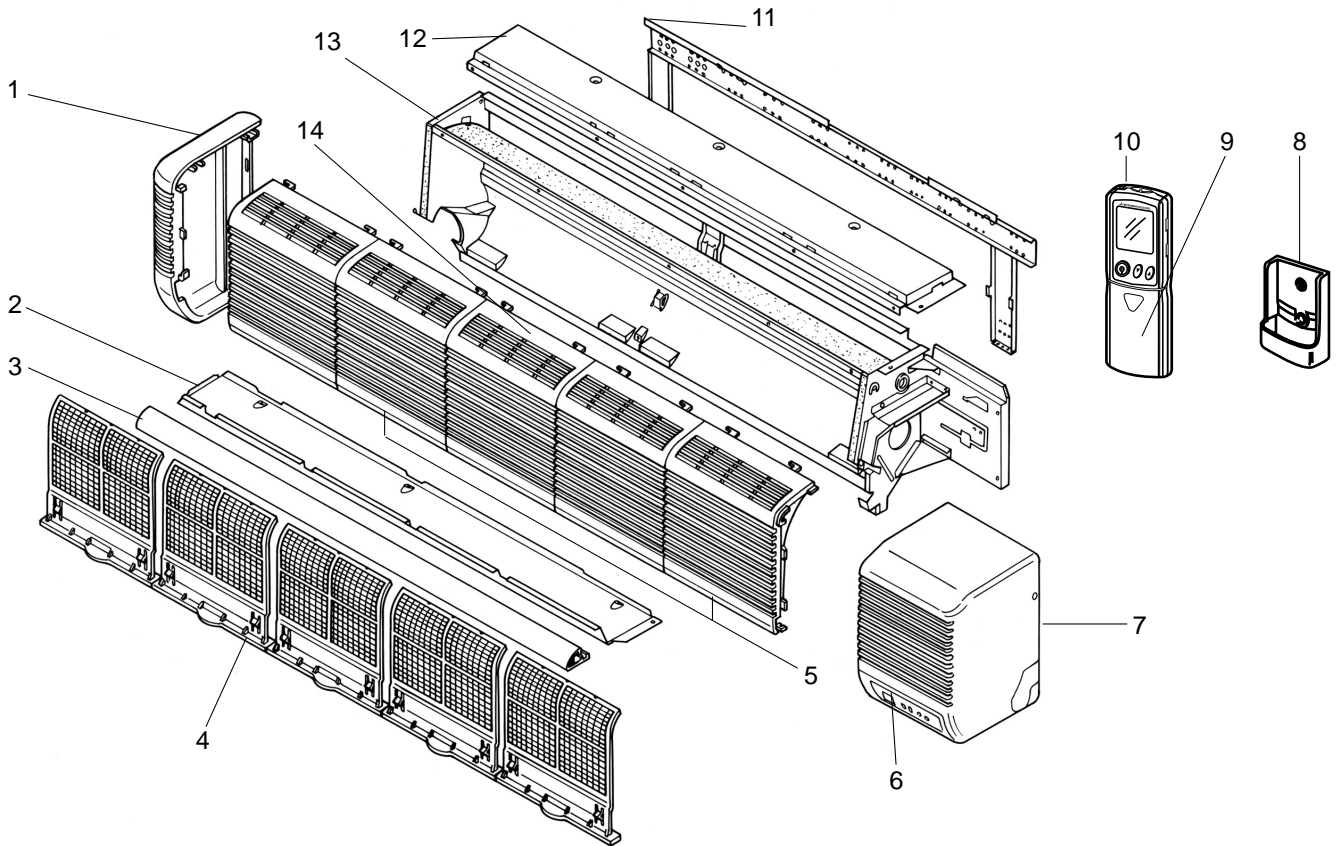

Part number that is circled is not shown in the figure.

No.	RoHS	Part No.	Part Name	Specifications	Q'ty/set			Remarks (Drawing No.)	Wiring Diagram Symbol	Recom- mended Q'ty
					PKA-RP		PKH-P			
					100FAL	100FAL#1	100FALH			
1	G	R01 14G 662	LEFT SIDE PANEL		1	1	1			
2	G	R01 E03 812	UNDER PLATE		1	1	1			
3	G	R01 E01 811	NOSE		1	1	1			
4	G	R01 A17 500	AIR FILTER		5	5	5			
5	G	R01 17G 691	INTAKE GRILLE		2	2	2			
6	G	R01 E18 658	RECEIVER		1	1	1		RU	
7	G	T7W E18 661	RIGHT SIDE PANEL		1	1	1			
8	G	R01 E00 075	WIRELESS REMOTE CONTROLLER HOLDER		1	1	1			
9	G	R01 E03 049	WIRELESS REMOTE CONTROLLER DOOR		1	1	1			
10	G	T7W E10 714	WIRELESS REMOTE CONTROLLER		1	1	1			
11	G	R01 E04 808	BACK PLATE		1	1	1			
12	G	R01 E20 641	TOP PLATE		1	1	1			
13	G	—	BOX ASSEMBLY		1	1		(RG00A734GP6)		
	G	—	BOX ASSEMBLY				1	(RG00A734GP8)		
14	G	R01 18G 692	INTAKE GRILLE		1	1	1			
⑮	G	R01 E02 523	DRAIN SOCKET		1	1	1			

Mr. SLIM™

 **MITSUBISHI ELECTRIC CORPORATION**

HEAD OFFICE : TOKYO BLDG., 2-7-3, MARUNOUCHI, CHIYODA-KU, TOKYO 100-8310, JAPAN

©Copyright 2005 MITSUBISHI ELECTRIC ENGINEERING CO., LTD.
Distributed in May 2008 No.OC331 REVISED EDITION-B PDF 7
Distributed in Jun. 2006 No.OC331 REVISED EDITION-A PDF 8
Distributed in May 2005 No.OC331 PDF 9
Made in Japan.

New publication, effective May 2008.
Specifications subject to change without notice.