

# TECHNICAL & SERVICE MANUAL

**R410A**

**Outdoor unit**

[Model names]	[Service Ref.]	
SUZ-KA25VA	SUZ-KA25VA.TH	SUZ-KA25VAR1.TH
SUZ-KA35VA	SUZ-KA35VA.TH	SUZ-KA35VAR1.TH
SUZ-KA25VAH	SUZ-KA25VAH.TH	SUZ-KA25VAHR1.TH
SUZ-KA35VAH	SUZ-KA35VAH.TH	SUZ-KA35VAHR1.TH
SUZ-KA50VA	SUZ-KA50VA.TH	
	SUZ-KA50VA <sub>1</sub> .TH	
	SUZ-KA50VAR2.TH	
SUZ-KA60VA	SUZ-KA60VA.TH	
	SUZ-KA60VA <sub>1</sub> .TH	
	SUZ-KA60VAR2.TH	
SUZ-KA71VA	SUZ-KA71VA.TH	
	SUZ-KA71VA <sub>1</sub> .TH	

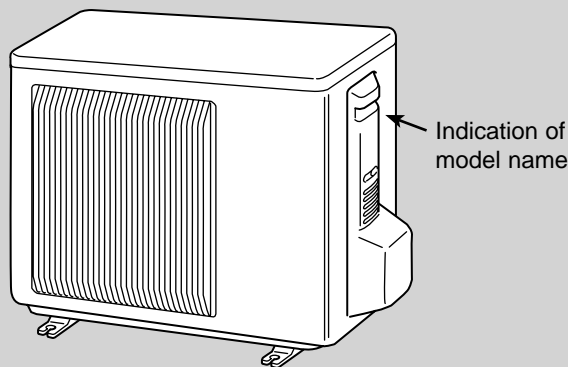

SUZ-KA25VA(H).TH	SUZ-KA25VA(H)R1.TH
SUZ-KA35VA(H).TH	SUZ-KA35VA(H)R1.TH

## CONTENTS

1. COMBINATION OF INDOOR AND OUTDOOR UNITS....	2
2. TECHNICAL CHANGES .....	3
3. PART NAMES AND FUNCTIONS.....	7
4. SPECIFICATION.....	8
5. NOISE CRITERIA CURVES.....	12
6. OUTLINES AND DIMENSIONS.....	13
7. WIRING DIAGRAM.....	15
8. REFRIGERANT SYSTEM DIAGRAM.....	23
9. PERFORMANCE CURVES.....	29
10. ACTUATOR CONTROL.....	57
11. SERVICE FUNCTIONS.....	58
12. TROUBLESHOOTING.....	58
13. DISASSEMBLY INSTRUCTIONS.....	103
14. PARTS LIST.....	113
15. RoHS PARTS LIST.....	119

**Revision:**

- "15. RoHS PARTS LIST" has been modified in REVISED EDITION-H.

- Please void OC322 REVISED EDITION-G.

**Note:**

This service manual describes technical data of the outdoor units.

RoHS compliant products have <G> mark on the spec name plate. For servicing of RoHS compliant products, refer to the RoHS Parts List.

**Revision:**

"15. RoHS PARTS LIST" has been modified on page 127 and 129.

Revised point	Page	Service Ref.	Incorrect	Correct
OUTDOOR UNIT STRUCTURAL PARTS No.8 FAN GUARD	127	SUZ-KA50VA.TH SUZ-KA50VA1.TH SUZ-KA60VA1.TH SUZ-KA71VA1.TH SUZ-KA60VAR2.TH	E12 819 521	E12 D84 521
	129	SUZ-KA50VAR2.TH		

# 1 COMBINATION OF INDOOR AND OUTDOOR UNITS

## 1-1. INDOOR UNIT SERVICE MANUAL

	Indoor unit		Outdoor unit				
			Heat pump type				
			SUZ-				
Service Ref.	Service Manual No.	KA25VA(H).TH	KA35VA(H).TH	KA50VA <sup>(1)</sup> .TH	KA60VA <sup>(1)</sup> .TH	KA71VA <sup>(1)</sup> .TH	
		KA25VA(H)R1.TH	KA35VA(H)R1.TH	KA50VAR2.TH	KA60VAR2.TH		
Heat pump without electric heater	SLZ-KA25VA(L).TH	OC320	○	—	—	—	—
	SLZ-KA35VA(L).TH		—	○	—	—	—
	SLZ-KA50VA(L).TH		—	—	○	—	—
	SEZ-KC25VA.W	—	○	—	—	—	—
	SEZ-KA35VA.TH	OC321	—	○	—	—	—
	SEZ-KA50VA.TH		—	—	○	—	—
	SEZ-KA60VA.TH		—	—	—	○	—
	SEZ-KA71VA.TH		—	—	—	—	○
	SEZ-KD25VA(L).TH	HWE0711	○	—	—	—	—
	SEZ-KD35VA(L).TH		—	○	—	—	—
	SEZ-KD50VA(L).TH		—	—	○	—	—
	SEZ-KD60VA(L).TH		—	—	—	○	—
	SEZ-KD71VA(L).TH		—	—	—	—	○
	MFZ-KA25VA-E1	OB409	○	—	—	—	—
	MFZ-KA35VA-E1		—	○	—	—	—
MFZ-KA50VA-E1	—		—	○	—	—	

(NOTE) • Please refer to the service manual of indoor unit or the technical data book for the combination data.  
 • Only MFZ-KA-VA series can be connected to SUZ-KA-VAH series.

## 1-2. TECHNICAL DATA BOOK

OCS03

**SUZ-KA25VA.TH → SUZ-KA25VAR1.TH**  
**SUZ-KA25VAH.TH → SUZ-KA25VAHR1.TH**  
**SUZ-KA35VA.TH → SUZ-KA35VAR1.TH**  
**SUZ-KA35VAH.TH → SUZ-KA35VAHR1.TH**

- Inverter P.C. board and Power P.C. board have been changed.
- Refrigerant circuit has been changed.
  - Compressor has been changed. (KNB073FDVH(C) → KNB073FFDHC : SUZ-KA25VA(H)R1.TH)  
 (KNB092FCAH → KNB092FFAHC : SUZ-KA35VA(H)R1.TH)
  - Muffler of liquid pipe side has been deleted.
  - Muffler of gas pipe side has been changed.
  - Capillary tube of liquid pipe side has been added. (SUZ-KA35VA(H)R1.TH)
  - 4-way valve and R.V. coil have been changed.
  - Specification of LEV body has been changed.
  - Stop valve has been changed.
- Precharged refrigerant amount has been changed. (900g → 800g : SUZ-KA25VA(H)R1.TH)
- Fan motor has been changed. (RC0J50-AL → RC0J50-DB)
- Outdoor heat exchanger temperature thermistor (RT68) has been added.

**SUZ-KA50VA<sub>1</sub>.TH → SUZ-KA50VAR2.TH**  
**SUZ-KA60VA<sub>1</sub>.TH → SUZ-KA60VAR2.TH**

- OUTDOOR ELECTRONIC CONTROL P.C. BOARD has been changed.
- Compressor has been changed. (SNB130FLDH(1) → SNB130FGBH)
- High pressure switch has been added. (SUZ-KA60VAR2.TH)
- Thermistors (RT61, 62, 64, 65, 68) have been changed. (SUZ-KA50VAR2.TH)

**SUZ-KA50VA.TH → SUZ-KA50VA<sub>1</sub>.TH**  
**SUZ-KA60VA.TH → SUZ-KA60VA<sub>1</sub>.TH**  
**SUZ-KA71VA.TH → SUZ-KA71VA<sub>1</sub>.TH**

- OUTDOOR ELECTRONIC CONTROL P.C. BOARD has been changed.
- Max. height difference 15m → 30m (Except when combined with MFZ).
- Guaranteed operating range  
 Lower limit (Cooling/Outdoor) -10°C DB → -15°C DB (Except when combined with MFZ)

**SUZ-KA25VA.TH**  
**SUZ-KA35VA.TH**

Lower limit (Heating/Outdoor) -10°C DB → -15°C DB.

**SUZ-KA35VAH.TH**

Defrost finish temperature has been changed (Refer to 11. SERVICE FUNCTIONS).

**SUZ-A09VR.TH → SUZ-KA25VA.TH**  
**SUZ-A12VR.TH → SUZ-KA35VA.TH**

- Indication of capacity has been changed. (BTU base → kW base)
- Control method between indoor and outdoor unit has been changed.
- Power supply method has been changed (change to supply from outdoor unit).
- Terminal block for power supply has been added.
- Power P.C. board has been changed.
- Inverter P.C. board has been changed.
- Refrigerant circuit has been changed.
  - Compressor has been changed. (KNB073FBVH → KNB073FDVH:SUZ-KA25VA) (KNB092FAAH → KNB092FCAH:SUZ-KA35VA)
  - Specification and position of muffler have been changed.
  - Path of outdoor heat exchanger has been changed.
  - 4-way valve and R.V. coil have been changed.
  - Stop valve has been changed.
- Fan motor has been changed. (AC → DC)
- Shape of grille has been changed.
- Shape of service panel has been changed.
- Shape of propeller has been changed.
- Symbol on terminal block has been changed (to S1/S2/S3).

**SUZ-A18VR → SUZ-KA50VA.TH**  
**SUZ-A24VR → SUZ-KA60VA.TH**

1. Indication of capacity has been changed.(BTU base → kW base)
2. Power supply method has been changed (change to supply from outdoor unit).
3. Outdoor electronic control P.C. board has been changed.
4. Noise filter P.C. board has been changed.
5. Length of fan motor lead wire has been changed.
6. Shape of relay panel has been changed.
7. Symbol on terminal block has been changed (to S1/S2/S3).
8. Control method between indoor and outdoor unit has been changed.

**INFORMATION FOR THE AIR CONDITIONER WITH R410A REFRIGERANT**

- This room air conditioner adopts an HFC refrigerant (R410A) which never destroys the ozone layer.
- Pay particular attention to the following points, though the basic installation procedure is same as that for R22 conditioners.
  - ① As R410A has working pressure approximate 1.6 times as high as that of R22, some special tools and piping parts/materials are required. Refer to the table below.
  - ② Take sufficient care not to allow water and other contaminations to enter the R410A refrigerant during storage and installation, since it is more susceptible to contaminations than R22.
  - ③ For refrigerant piping, use clean, pressure-proof parts/materials specifically designed for R410A. (Refer to 2. Refrigerant piping.)
  - ④ Composition change may occur in R410A since it is a mixed refrigerant. When charging, charge liquid refrigerant to prevent composition change.

		New refrigerant	Previous refrigerant
Refrigerant	Refrigerant	R410A	R22
	Composition (Ratio)	HFC-32: HFC-125 (50%:50%)	R22 (100%)
	Refrigerant handling	Pseudo-azeotropic refrigerant	Single refrigerant
	Chlorine	Not included	Included
	Safety group (ASHRAE)	A1/A1	A1
	Molecular weight	72.6	86.5
	Boiling point (°C)	-51.4	-40.8
	Steam pressure [25°C](Mpa)	1.557	0.94
	Saturated steam density [25°C](Kg/m³)	64	44.4
	Combustibility	Non combustible	Non combustible
	ODP ※1	0	0.055
	GWP ※2	1730	1700
	Refrigerant charge method	From liquid phase in cylinder	Gas phase
Additional charge on leakage	Possible	Possible	
Refrigerant oil	Kind	Incompatible oil	Compatible oil
	Color	None	Light yellow
	Smell	None	None

※1: Ozone Depletion Potential : based on CFC-11

※2: Global Warming Potential : based on CO<sub>2</sub>



	New Specification	Current Specification
Compressor	<p>The incompatible refrigerant oil easily separates from refrigerant and is in the upper layer inside the suction muffler. Raising position of the oil back hole enables to back the refrigerant oil of the upper layer to flow back to the compressor.</p>	<p>Since refrigerant and refrigerant oil are compatible with each other, refrigerant oil backs to the compressor through the lower position oil back hole.</p>

**NOTE :** The unit of pressure has been changed to MPa on the international system of units (SI unit system).  
 The conversion factor is: **1 (MPa [Gauge]) =10.2 (kgf/cm<sup>2</sup> [Gauge])**

Conversion chart of refrigerant temperature and pressure

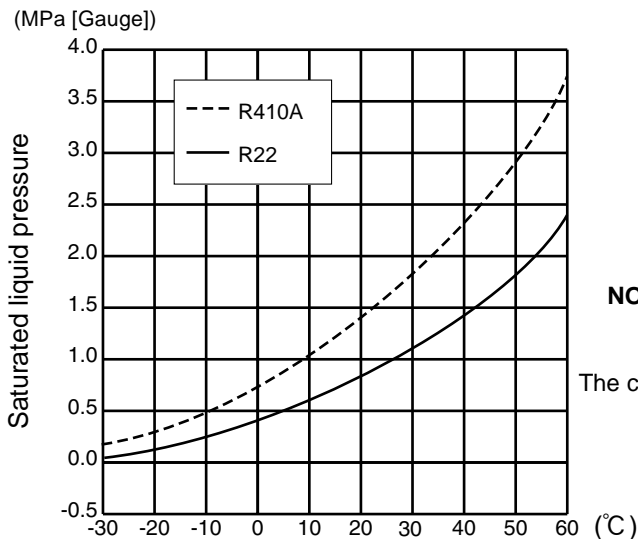

**NOTE:** The unit of pressure has been changed to MPa on the international system of units (SI unit system).

The conversion factor is: **1 (MPa [Gauge]) =10.2 (kgf/cm<sup>2</sup> [Gauge])**

**1. Tools dedicated for the air conditioner with R410A refrigerant**

The following tools are required for R410A refrigerant. Some R22 tools can be substituted for R410A tools. The diameter of the service port on the stop valve in outdoor unit has been changed to prevent any other refrigerant being charged into the unit. Cap size has been changed from 7/16 UNF with 20 threads to 1/2 UNF with 20 threads.

R410A tools	Can R22 tools be used?	Description
Gauge manifold	No	R410A has high pressures beyond the measurement range of existing gauges. Port diameters have been changed to prevent any other refrigerant from being charged into the unit.
Charge hose	No	Hose material and cap size have been changed to improve the pressure resistance.
Gas leak detector	No	Dedicated for HFC refrigerant.
Torque wrench	Yes	6.35 mm and 9.52 mm
	No	12.7 mm and 15.88 mm
Flare tool	Yes	Clamp bar hole has been enlarged to reinforce the spring strength in the tool.
Flare gauge	New	Provided for flaring work (to be used with R22 flare tool).
Vacuum pump adapter	New	Provided to prevent the back flow of oil. This adapter enables you to use vacuum pumps.
Electronic scale for refrigerant charging	New	It is difficult to measure R410A with a charging cylinder because the refrigerant bubbles due to high pressure and high-speed vaporization

No: Not substitutable for R410A    Yes: Substitutable for R410A

## 2. Refrigerant piping

### ① Specifications

Use the refrigerant pipes that meet the following specifications.

Pipe	Outside diameter	Wall thickness	Insulation material
	mm	mm	
For liquid	6.35	0.8	Heat resisting foam plastic Specific gravity 0.045 Thickness 8 mm
	9.52	0.8	
For gas	9.52	0.8	
	12.7	0.8	
	15.88	1.0	

- Use a copper pipe or a copper-alloy seamless pipe with a thickness of 0.8 mm. Never use any pipe with a thickness less than 0.8mm, as the pressure resistance is insufficient.

### ② Flaring work and flare nut

Flaring work for R410A pipe differs from that for R22 pipe.

For details of flaring work, refer to Installation manual "FLARING WORK".

Pipe diameter (mm)	Dimension of flare nut (mm)	
	R410A	R22
6.35	17	17
9.52	22	22
12.7	26	24
15.88	29	27

## 3. Refrigerant oil

Apply the special refrigerant oil (accessories: packed with indoor unit) to the flare and the union seat surfaces.

## 4. Air purge

- Do not discharge the refrigerant into the atmosphere.
- Take care not to discharge refrigerant into the atmosphere during installation, reinstallation, or repairs to the refrigerant circuit.
- Use the vacuum pump for air purging for the purpose of environmental protection.

## 5. Additional charge

For additional charging, charge the refrigerant from liquid phase of the gas cylinder.

If the refrigerant is charged from the gas phase, composition change may occur in the refrigerant inside the cylinder and the outdoor unit. In this case, ability of the refrigerating cycle decreases or normal operation can be impossible. However, charging the liquid refrigerant all at once may cause the compressor to be locked. Thus, charge the refrigerant slowly.

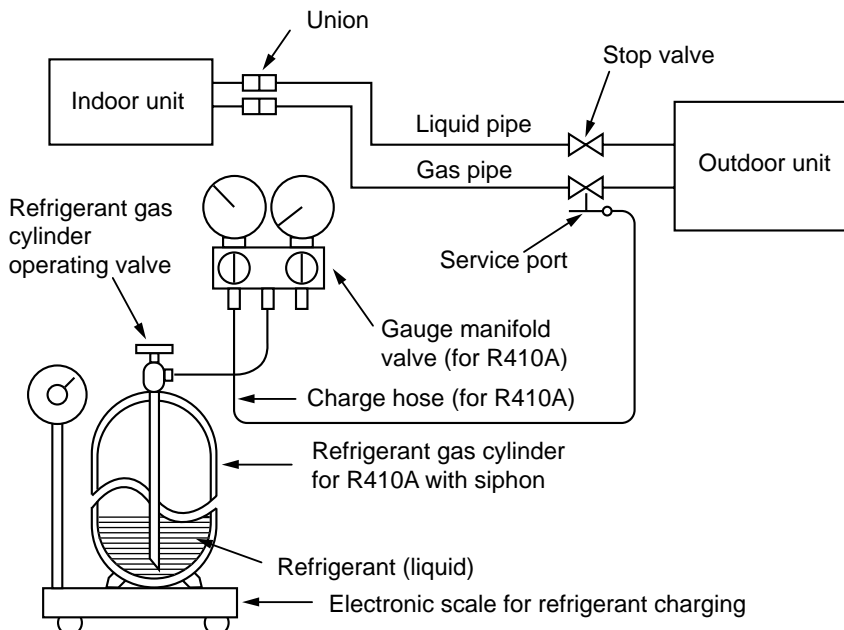

# 3

## PART NAMES AND FUNCTIONS

SUZ-KA25VA.TH  
 SUZ-KA35VA.TH  
 SUZ-KA25VAH.TH  
 SUZ-KA35VAH.TH

SUZ-KA25VAR1.TH  
 SUZ-KA35VAR1.TH  
 SUZ-KA25VAHR1.TH  
 SUZ-KA35VAHR1.TH

### OUTDOOR UNIT

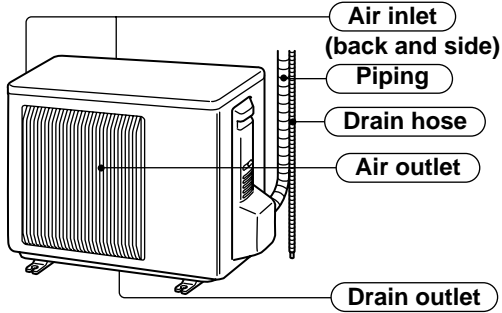

### ACCESSORIES

		SUZ-KA25VA.TH SUZ-KA35VA.TH SUZ-KA25VAR1.TH SUZ-KA35VAR1.TH
		1
①	Drain socket	

SUZ-KA50VA.TH  
 SUZ-KA60VA.TH  
 SUZ-KA71VA.TH

SUZ-KA50VA<sub>1</sub>.TH  
 SUZ-KA60VA<sub>1</sub>.TH  
 SUZ-KA71VA<sub>1</sub>.TH

SUZ-KA50VAR2.TH  
 SUZ-KA60VAR2.TH

### OUTDOOR UNIT

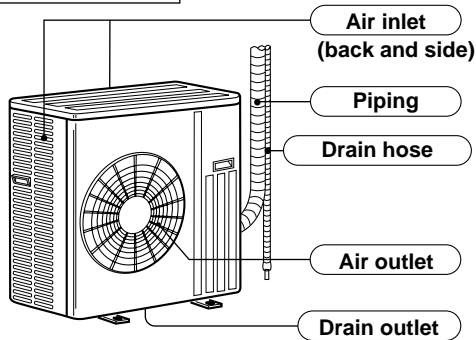

### ACCESSORIES

		SUZ-KA50VA <sub>(1)</sub> .TH SUZ-KA60VA <sub>(1)</sub> .TH SUZ-KA71VA <sub>(1)</sub> .TH SUZ-KA50VAR2.TH SUZ-KA60VAR2.TH
		1
①	Drain socket	
②	Drain cap $\phi 33$	2

## 4

## SPECIFICATION

Outdoor Service Ref.		SUZ-KA25VA(H).TH	SUZ-KA25VA(H)R1.TH	SUZ-KA35VA(H).TH	SUZ-KA35VA(H)R1.TH	SUZ-KA50VA.TH	SUZ-KA50VA.1.TH	
Function		Cooling   Heating	Cooling   Heating	Cooling   Heating	Cooling   Heating	Cooling   Heating	Cooling   Heating	
Power supply		Single phase 230V, 50Hz		Single phase 230V, 50Hz		Single phase 230V, 50Hz		
Electrical data	Starting current *1	A	3.65		3.65		4.75	
	Compressor motor current *1	A	2.74	3.37	2.74	3.37	4.22	4.42
	Fan motor current *1	A	0.31	0.28	0.31	0.28	0.33	0.33
Compressor	Model		KNB073FDVH(C)		KNB073FFDH(C)		KNB092FCAH	
	Output	W	550		550		650	
	Winding resistance (at 20°C)	Ω	U-V 1.53 U-W 1.53 V-W 1.53	U-V 1.70 U-W 1.70 V-W 1.70	U-V 0.49 U-W 0.49 V-W 0.49	U-V 1.91 U-W 1.91 V-W 1.91	U-V 0.45 U-W 0.45 V-W 0.45	U-V 0.45 U-W 0.45 V-W 0.45
Fan motor	Model		RC0J50-AL		RC0J50-DB		RC0J50-AL	
	Winding resistance(at 20°C)	Ω	WHT-BLK 37.5 BLK-RED 37.5 RED-WHT 37.5	WHT-BLK 37.0 BLK-RED 37.0 RED-WHT 37.0	WHT-BLK 37.5 BLK-RED 37.5 RED-WHT 37.5	WHT-BLK 37.0 BLK-RED 37.0 RED-WHT 37.0	WHT-BLK 15.2 BLK-RED 15.2 RED-WHT 15.2	WHT-BLK 15.2 BLK-RED 15.2 RED-WHT 15.2
	Air flow(High/Low*)	m³/h	2,058	1,938	2,058	1,938	2,004	
Dimensions W×H×D		mm	800×550×285		800×550×285		800×550×285	
Weight		kg	33		30		37	
Special remarks	Sound level *1	dB	46		46		47	48
	Fan speed(High*/Low*, High*/Med*/Low*)	rpm	810*/650*	880*/810*/650*	810*/650*	880*/810*/650*	840*/760*	880*/800*/630*
	Fan speed regulator		2	3	2	3	2	3
	Refrigerant filling capacity(R410A)	kg	0.90		0.80		1.05	
	Refrigerating oil (Model)	cc	320 (NEO22)		320 (NEO22)		320 (NEO22)	
							FLDH: 450/FLDH1: 600(NEO22)	

NOTE : Test conditions are based on ISO 5151

Cooling : Indoor D.B. 27°C W.B. 19°C

Outdoor D.B. 35°C W.B. 24°C

Heating : Indoor D.B. 20°C W.B. 15°C

Outdoor D.B. 7°C W.B. 6°C

Refrigerant piping length (one way): 5m

\*1 Measured under rated operating frequency.

\* Reference value



Outdoor Service Ref.			SUZ-KA50VAR2.TH		SUZ-KA60VA.TH SUZ-KA60VA1.TH		SUZ-KA60VAR2.TH		SUZ-KA71VA.TH SUZ-KA71VA1.TH		
Function			Cooling	Heating	Cooling	Heating	Cooling	Heating	Cooling	Heating	
Power supply			Single phase 230V, 50Hz		Single phase 230V, 50Hz		Single phase 230V, 50Hz		Single phase 230V, 50Hz		
Electrical data	Starting current *1	A	6.75		9.75		9.75		10.30		
	Compressor motor current *1	A	6.45	6.05	8.05	9.45	8.05	9.45	10.00	9.60	
	Fan motor current *1	A	0.30		0.30		0.30		0.30		
Compressor	Model		SNB130FGBH(T)		SNB130FLDH or SNB130FLDH1		SNB130FGBH(T)		TNB220FMCH(T)		
	Output	W	900		850		900		1300		
	Winding resistance (at 20°C)	Ω	U-V 0.98	U-W 0.98	U-V 0.45	U-W 0.45	U-V 0.98	U-W 0.98	U-V 1.41	U-W 1.41	
Fan motor	Model		RC0J60-AA		RC0J60-AA		RC0J60-AA		RC0J60-AA		
	Winding resistance(at 20°C)	Ω	WHT-BLK 15.2 BLK-RED 15.2 RED-WHT 15.2		WHT-BLK 15.2 BLK-RED 15.2 RED-WHT 15.2		WHT-BLK 15.2 BLK-RED 15.2 RED-WHT 15.2		WHT-BLK 15.2 BLK-RED 15.2 RED-WHT 15.2		
	Air flow(High/Low*)	m³ /h	2,940/1,650*	2,940/2,210*	2,940/1650*	2,940/2,210*	2,940/1650*	2,940/2,210*	2,940/1650*	2,940/2,210*	
Dimensions W×H×D		mm	840×850×330		840×850×330		840×850×330		840×850×330		
Weight		kg	53		53		53		58		
Special remarks	Sound level *1	dB	53/51*	55/53*	53/51*	55/53*	53/51*	55/53*	53/51*	55/53*	
	Fan speed(High*/Low*, High*/Med*/Low*)	rpm	800/480*	800/620*	800/480*	800/620*	800/480*	800/620*	800/480*	800/620*	
	Fan speed regulator			2		2		2		2	
	Refrigerant filling capacity(R410A)	kg	1.60		1.80		1.80		2.00		
	Refrigerating oil (Model)	cc	450 (NEO22)		FLDH: 450/FLDH1: 600 (NEO22)		450 (NEO22)		870 (NEO22)		

NOTE : Test conditions are based on ISO 5151  
Cooling : Indoor D.B. 27°C W.B. 19°C  
Outdoor D.B. 35°C W.B. 24°C  
Heating : Indoor D.B. 20°C W.B. 15°C  
Outdoor D.B. 7°C W.B. 6°C  
Refrigerant piping length (one way): 5m  
\*1 Measured under rated operating frequency.  
\* Reference value

**Specifications and rating conditions of main electric parts**  
**SUZ-KA25VA.TH SUZ-KA25VAH.TH**  
**SUZ-KA35VA.TH SUZ-KA35VAH.TH**

Item	Model	SUZ-KA25VA.TH	SUZ-KA25VAH.TH	SUZ-KA35VA.TH	SUZ-KA35VAH.TH
Current transformer	(CT)	ETA19Z59BZ			
Current transformer	(CT761, CT781)	ETQ19Z71AY			
Smoothing capacitor	(C63A, C63B, C63C)	620 $\mu$ F 420V			
Diode module	(DB61, DB65)	D25xB60			
Fuse	(F61)	250V 20A			
Fuse	(F71, F801, F901)	250V 3.15A			
Defrost heater	(H)	—	230V 130W	—	230V 130W
Intelligent power module	(IPM)	PS21244-A-203			
Expansion valve coil	(LEV)	CAD-MD12ME 12VDC			
Reactor	(L61)	10A 23.0mH			
Current-detecting resistor	(R61)	45m $\Omega$ 5W (1 element)		50m $\Omega$ 5W (2 elements)	
Current-detecting resistor	(R831)	25m $\Omega$ 5W			
Current-limiting resistor	(R64A, R64B)	5.1 $\Omega$ 5W			
Terminal block	(TB1, TB2)	3P			
Relay	(X63)	G5NB-1a			
Relay	(X64)	G4A-1A-PS			
Relay	(X66)	—	G5NB-1a	—	G5NB-1a
R.V. coil	(21S4)	STF-01AJ503			
Heater protector	(26H)	—	Open 45°C	—	Open 45°C

**SUZ-KA50VA.TH SUZ-KA50VA<sub>1</sub>.TH**  
**SUZ-KA60VA.TH SUZ-KA60VA<sub>1</sub>.TH SUZ-KA60VAR2.TH**  
**SUZ-KA71VA.TH SUZ-KA71VA<sub>1</sub>.TH**

Item	Model	SUZ-KA50VA.TH SUZ-KA50VA <sub>1</sub> .TH	SUZ-KA60VA.TH SUZ-KA60VA <sub>1</sub> .TH SUZ-KA60VAR2.TH	SUZ-KA71VA.TH SUZ-KA71VA <sub>1</sub> .TH
Smoothing capacitor	(CB1,2,3)	560 $\mu$ F 450V		
Current transformer	(CT1,2)	ETQ19Z68AY		
Current transformer	(CT61)	ETQ19Z53AY		
Fuse	(F64)	250V 2A		
Fuse	(F801)	250V 3.15A		
Fuse	(F911)	250V 1A		
Intelligent power module	(HC930)	PS21661-RZ		
High pressure switch	(HPS)	—	ACB-DB156 (for R2)	ACB-DB156
Intelligent power module	(IPM)	PS21244-A		
Reactor	(L)	340 $\mu$ H 20A		
Expansion valve coil	(LEV)	DC12V		
Power factor controller	(PFC)	PS51259-A		
Resistor	(R64A,B)	10 $\Omega$ 10W		
Resistor	(R937A,B)	1.1 $\Omega$ 2W 2%		
Resistor	(RS1~4)	0.04 $\Omega$ 7W		
Solenoid coil relay	(SSR61)	TLP3506		
Terminal block	(TB1)	3P		
Terminal block	(TB2)	3P		
Relay	(X64)	G4A		
R.V. coil	(21S4)	AC 220 - 240V		

**SUZ-KA25VAR1.TH SUZ-KA25VAHR1.TH**  
**SUZ-KA35VAR1.TH SUZ-KA35VAHR1.TH**  
**SUZ-KA50VAR2.TH**

Model		SUZ-KA25VAR1.TH	SUZ-KA25VAHR1.TH	SUZ-KA35VAR1.TH	SUZ-KA35VAHR1.TH	SUZ-KA50VAR2.TH
Current transformer	(CT)	20 A				
	(CT761, CT781)	15 A				
Smoothing capacitor	(C61)	—				620 μF 420 V
	(C62, C63)	620 μF 420 V				
Diode module	(DB61)	15 A 600 V				25 A 600 V
	(DB65)	25 A 600 V				
Fuse	(F61)	T20AL250V				
	(F701, F801, F901)	T3.15AL250V				
Defrost heater	(H)	—	230 V 130 W	—	230 V 130 W	—
Intelligent power module	(IPM)	15 A 600 V				20 A 600 V
Expansion valve coil	(LEV)	DC 12 V				
Reactor	(L61)	23 mH				
Current-detecting resistor	(R61)	45 mΩ 5 W (1 element)	100 mΩ 5 W (2 elements)			—
	(R61,R62)	—				180 mΩ 5 W (2 elements)
	(R825)	25 mΩ 5 W				
	(R937, R938, R939)	430 mΩ 2 W				—
	(R937A, R937B)	—				1.1 Ω 2 W
Current-limiting PTC thermistor	(PTC64, PTC65)	33 Ω				
Terminal block	(TB1, TB2)	3 P				
Relay	(X63)	3 A 250 V				
	(X64)	20 A 250 V				
	(X66)	—	3 A 250 V	—	3 A 250 V	—
R.V. coil	(21S4)	AC 220 - 240 V				
Heater protector	(26H)	—	Open 45°C	—	Open 45°C	—
IGBT	(TR821)	30 A 600 V				

# 5

# NOISE CRITERIA CURVES

SUZ-KA25VA.TH  
SUZ-KA25VAH.TH

SUZ-KA25VAR1.TH  
SUZ-KA25VAHR1.TH

SUZ-KA35VA.TH  
SUZ-KA35VAH.TH

SUZ-KA35VAR1.TH  
SUZ-KA35VAHR1.TH

FAN SPEED	FUNCTION	SPL(dB(A))	LINE
High Med.	COOLING	46	●—●
	HEATING	46	○—○

Test conditions,

Cooling : Dry-bulb temperature 35°C Wet-bulb temperature (24°C)  
Heating : Dry-bulb temperature 7°C Wet-bulb temperature 6°C

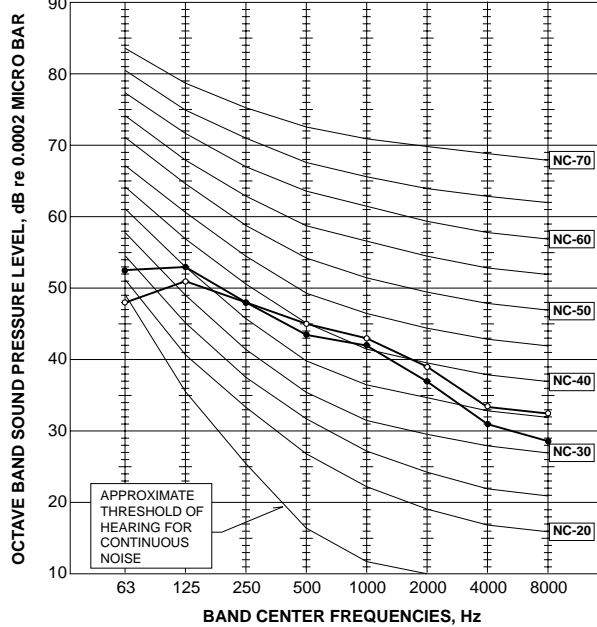

FAN SPEED	FUNCTION	SPL(dB(A))	LINE
High Med.	COOLING	47	●—●
	HEATING	48	○—○

Test conditions,

Cooling : Dry-bulb temperature 35°C Wet-bulb temperature (24°C)  
Heating : Dry-bulb temperature 7°C Wet-bulb temperature 6°C

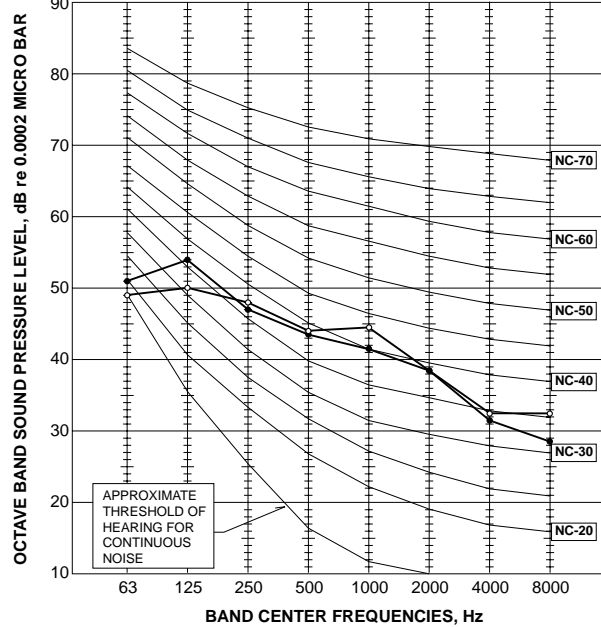

SUZ-KA50VA.TH SUZ-KA50VA1.TH SUZ-KA50VAR2.TH  
SUZ-KA60VA.TH SUZ-KA60VA1.TH SUZ-KA60VAR2.TH  
SUZ-KA71VA.TH SUZ-KA71VA1.TH

FAN SPEED	FUNCTION	SPL(dB(A))	LINE
High	COOLING	53	●—●
	HEATING	55	○—○

Test conditions,

Cooling : Dry-bulb temperature 35°C Wet-bulb temperature (24°C)  
Heating : Dry-bulb temperature 7°C Wet-bulb temperature 6°C

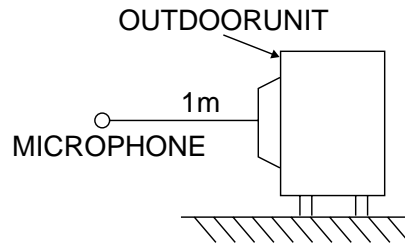
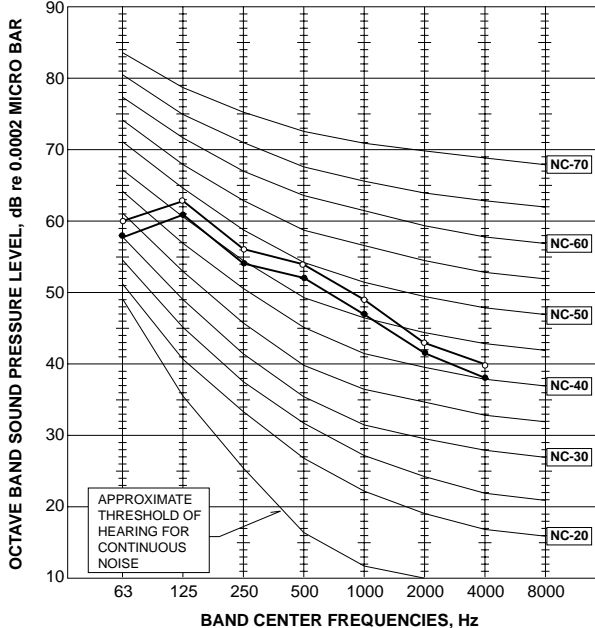

# 6

# OUTLINES AND DIMENSIONS

SUZ-KA25VA.TH SUZ-KA25VAH.TH SUZ-KA25VAR1.TH SUZ-KA25VAHR1.TH  
 SUZ-KA35VA.TH SUZ-KA35VAH.TH SUZ-KA35VAR1.TH SUZ-KA35VAHR1.TH

## OUTDOOR UNIT

Unit: mm

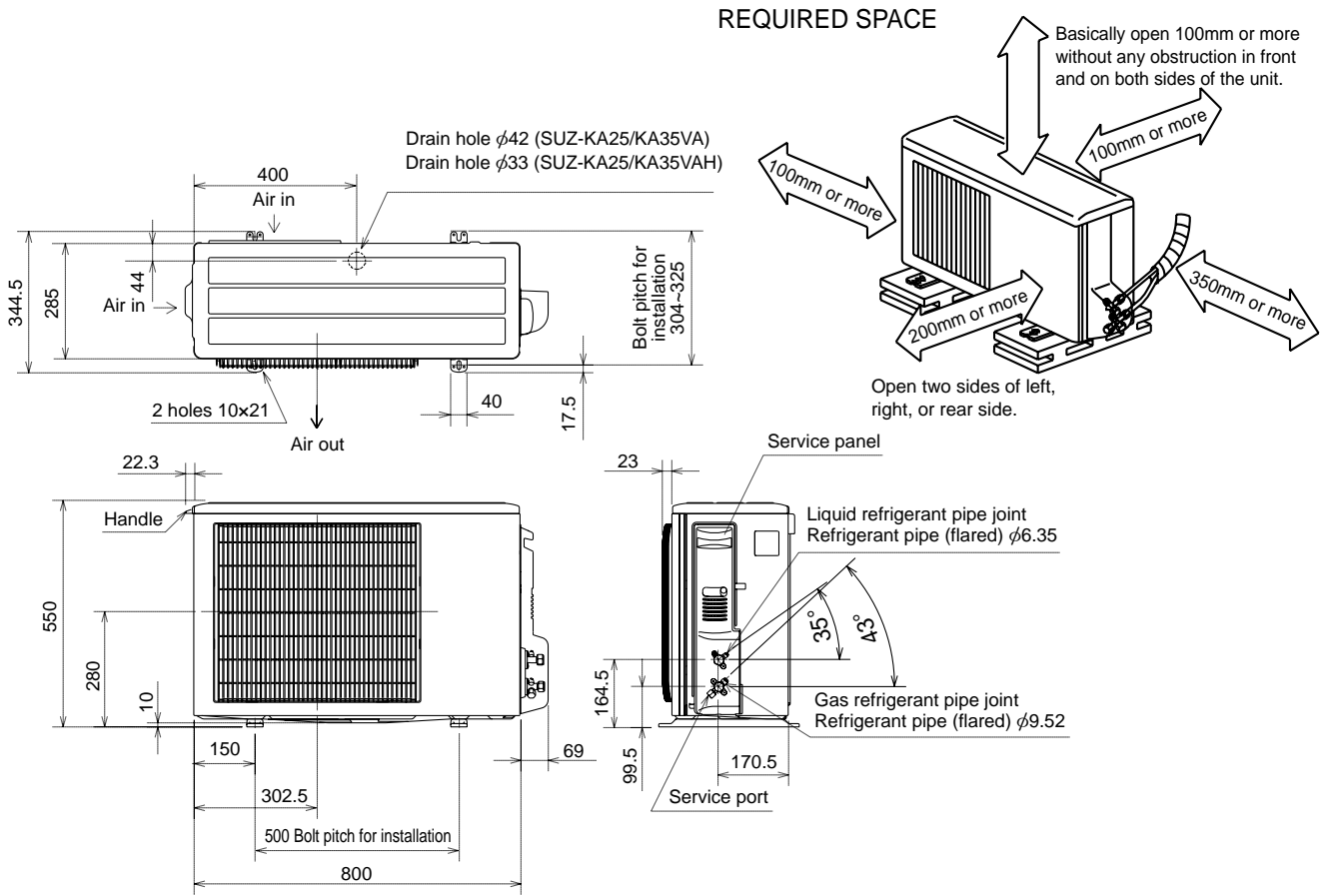

SUZ-KA50VA.TH SUZ-KA50VA<sub>1</sub>.TH SUZ-KA50VAR2.TH  
 SUZ-KA60VA.TH SUZ-KA60VA<sub>1</sub>.TH SUZ-KA60VAR2.TH  
 SUZ-KA71VA.TH SUZ-KA71VA<sub>1</sub>.TH

Unit: mm

**OUTDOOR UNIT**

REQUIRED SPACE

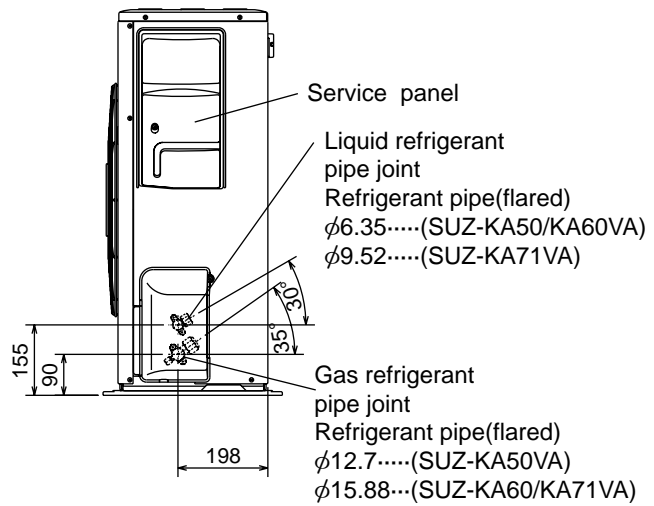
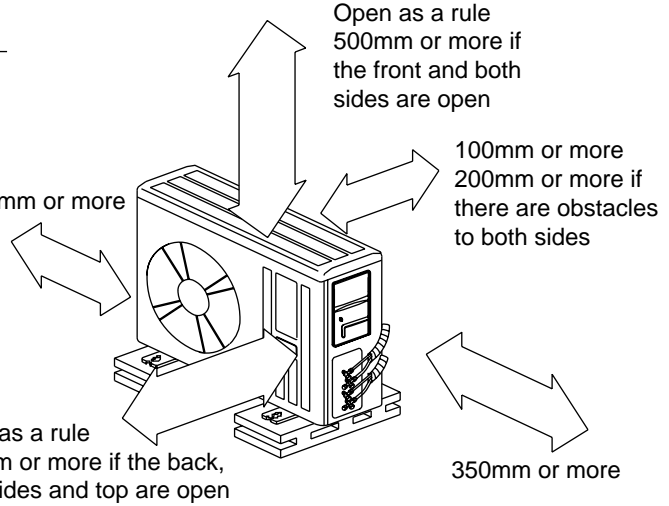
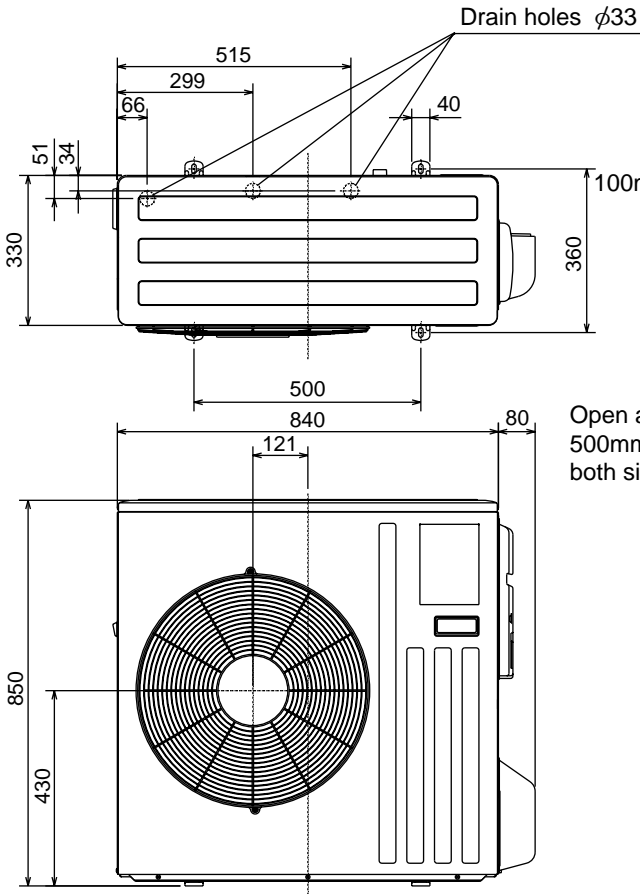

SUZ-KA25VA.TH  
SUZ-KA35VA.TH

OUTDOOR UNIT

MODELS WIRING DIAGRAM

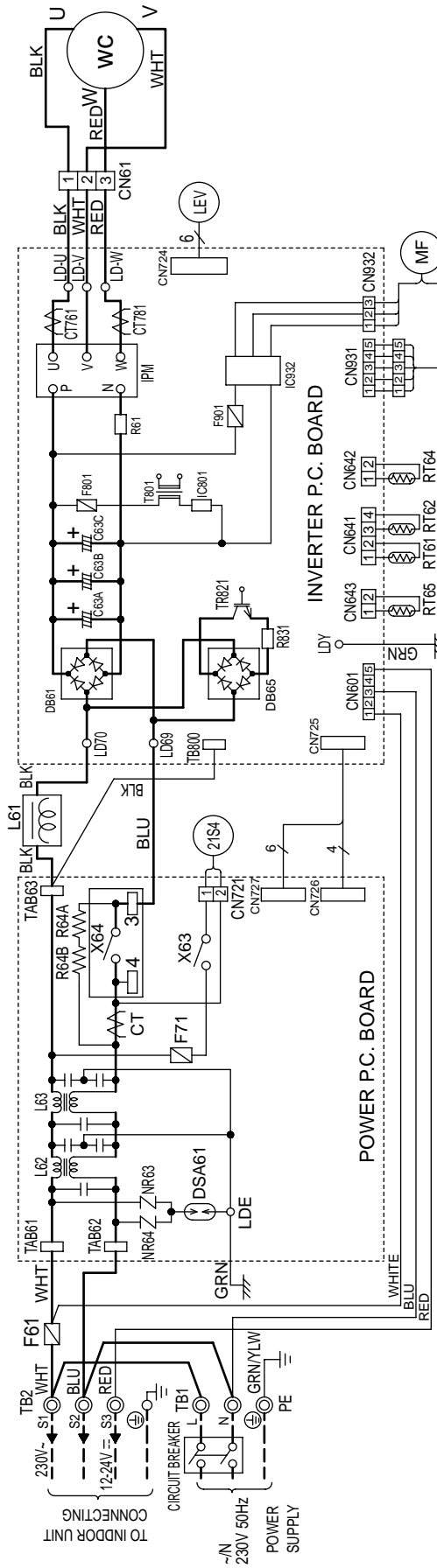

- NOTES: 1. About the indoor side electric wiring, refer to the indoor unit electric wiring diagram for servicing.  
2. Use copper conductors only. (For field wiring)  
3. Symbols below indicate.  
⊙ : Terminal block, □□□□ : Connector

SYMBOL	NAME	SYMBOL	NAME	SYMBOL	NAME
CT, CT761, CT781	CURRENT TRANSFORMER	L61	REACTOR	R61, R831	CURRENT-DETECTING RESISTOR
C63A, C63B, C63C	SMOOTHING CAPACITOR	L62, L63	CMC COIL	R64A, R64B	CURRENT-LIMITING RESISTOR
DB61, DB65	DIODE MODULE	MC	COMPRESSOR	TB1, TB2	TERMINAL BLOCK
DSA61	SURGE ABSORBER	MF	OUTDOOR FAN MOTOR	TR821	SWITCHING POWER TRANSISTOR
F61	FUSE (T20AL250V)	NR63, NR64	VARIATOR	T801	TRANSFORMER
F71	FUSE (T3.15AL250V)	RT61	DEFROST THERMISTOR	X63, X64	RELAY
F801, F901	FUSE (T3.15AL250V)	RT62	DISCHARGE TEMPERATURE THERMISTOR	21S4	REVERSING VALVE COIL
IC801	INTELLIGENT POWER DEVICE	RT64	FIN TEMPERATURE THERMISTOR	LEV	EXPANSION VALVE COIL
IPM, IC932	INTELLIGENT POWER MODULE	RT65	AMBIENT TEMPERATURE THERMISTOR		

SUZ-KA25VAR1.TH  
 SUZ-KA35VAR1.TH

OUTDOOR UNIT

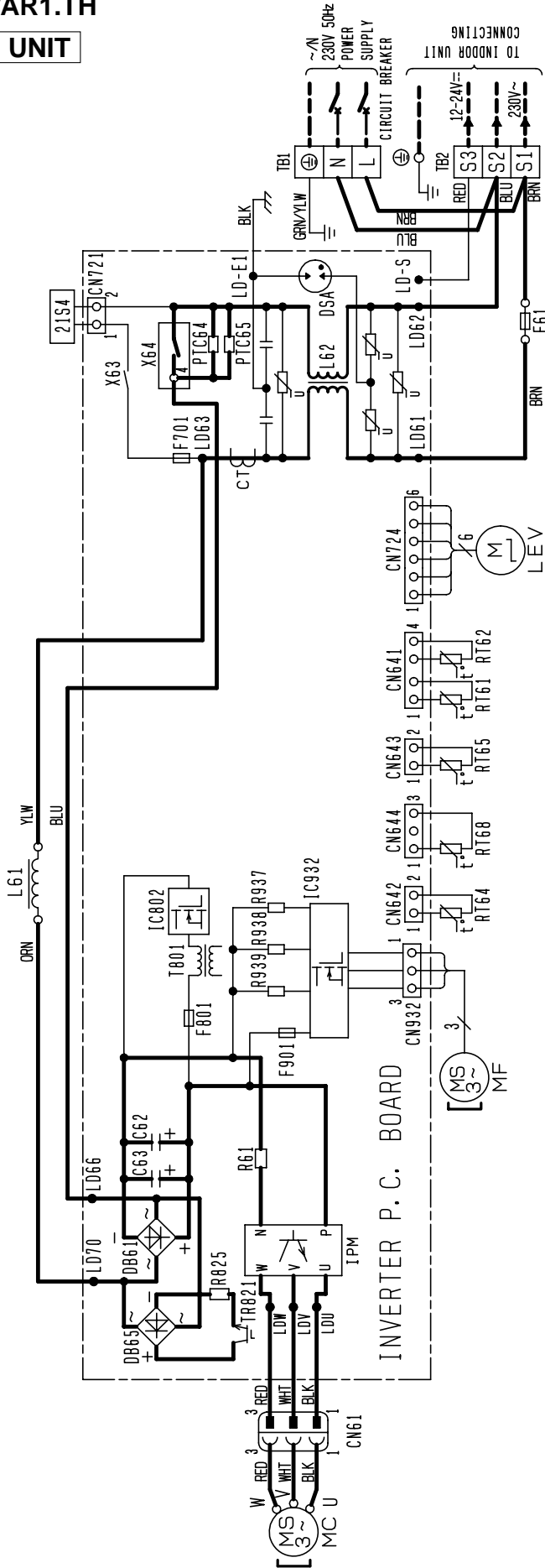

- NOTES: 1. About the indoor side electric wiring, refer to the indoor unit electric wiring diagram for servicing.  
 2. Use copper conductors only. (For field wiring)  
 3. Symbols below indicate.  
 □□□ : Terminal block

SYMBOL	NAME	SYMBOL	NAME	SYMBOL	NAME
CT	CURRENT TRANSFORMER	LEV	EXPANSION VALVE COIL	R61	CURRENT-DETECTING RESISTOR
C62, C63	SMOOTHING CAPACITOR	MC	COMPRESSOR	R825, R937	CURRENT-DETECTING RESISTOR
DB61, DB65	DIODE MODULE	MF	FAN MOTOR	R938, R939	CURRENT-DETECTING RESISTOR
DSA	SURGE ABSORBER	PTC64, PTC65	CIRCUIT PROTECTION	TBL, TB2	TERMINAL BLOCK
F61	FUSE (T20AL250V)	RT61	DEFROST THERMISTOR	TR821	SWITCHING POWER TRANSISTOR
F701, F801, F901	FUSE (T3, 15AL250V)	RT62	DISCHARGE TEMP. THERMISTOR	T801	TRANSFORMER
IC802	INTELLIGENT POWER DEVICE	RT64	FIN TEMP. THERMISTOR	X63, X64	RELAY
IPM, IC932	INTELLIGENT POWER MODULE	RT65	AMBIENT TEMP. THERMISTOR	21S4	REVERSING VALVE COIL
L61	REACTOR	RT68	OUTDOOR HEAT EXCHANGER TEMP. THERMISTOR.		
L62	CMC COIL				



**SUZ-KA25VAH.TH  
SUZ-KA35VAH.TH**

**OUTDOOR UNIT**

**MODELS WIRING DIAGRAM**

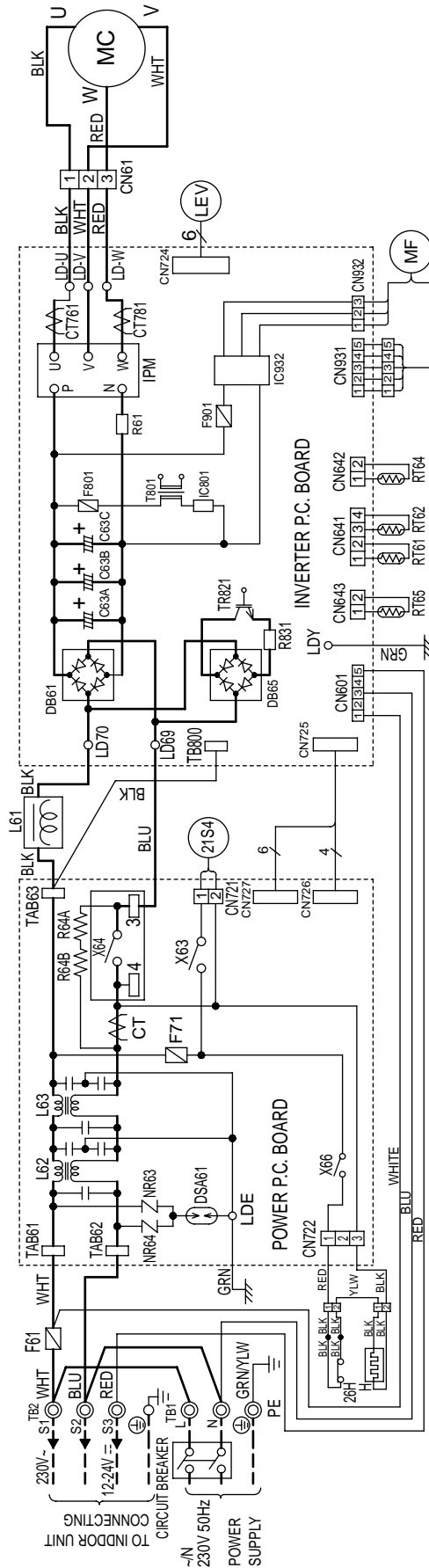

- NOTES: 1. About the indoor side electric wiring, refer to the indoor unit electric wiring diagram for servicing.  
2. Use copper conductors only. (For field wiring)  
3. Symbols below indicate.  
○: Terminal block, □□□□: Connector

SYMBOL	NAME	SYMBOL	NAME	SYMBOL	NAME
CT, CT761, CT781	CURRENT TRANSFORMER	L61	REACTOR	R64A, R64B	CURRENT-LIMITING RESISTOR
C63A, C63B, C63C	SMOOTHING CAPACITOR	L62, L63	CMC COIL	TB1, TB2	TERMINAL BLOCK
DB61, DB65	DIODE MODULE	MC	COMPRESSOR	TR821	SWITCHING POWER TRANSISTOR
DSA61	SURGE ABSORBER	MF	OUTDOOR FAN MOTOR	T801	TRANSFORMER
F61	FUSE (T20AL250V)	NR63, NR64	VARIATOR	X63, X64, X66	RELAY
F71	FUSE (T3.15AL250V)	RT61	DEFROST THERMISTOR	21S4	REVERSING VALVE COIL
F801, F901	FUSE (T3.15AL250V)	RT62	DISCHARGE TEMPERATURE THERMISTOR	H	DEFROST HEATER
IC801	INTELLIGENT POWER DEVICE	RT64	FIN TEMPERATURE THERMISTOR	26H	HEATER PROTECTOR
IPM, IC932	INTELLIGENT POWER MODULE	RT65	AMBIENT TEMPERATURE THERMISTOR		
LEV	EXPANSION VALVE COIL	R61, R831	CURRENT-DETECTING RESISTOR		

SUZ-KA25VAHR1.TH  
 SUZ-KA35VAHR1.TH

OUTDOOR UNIT

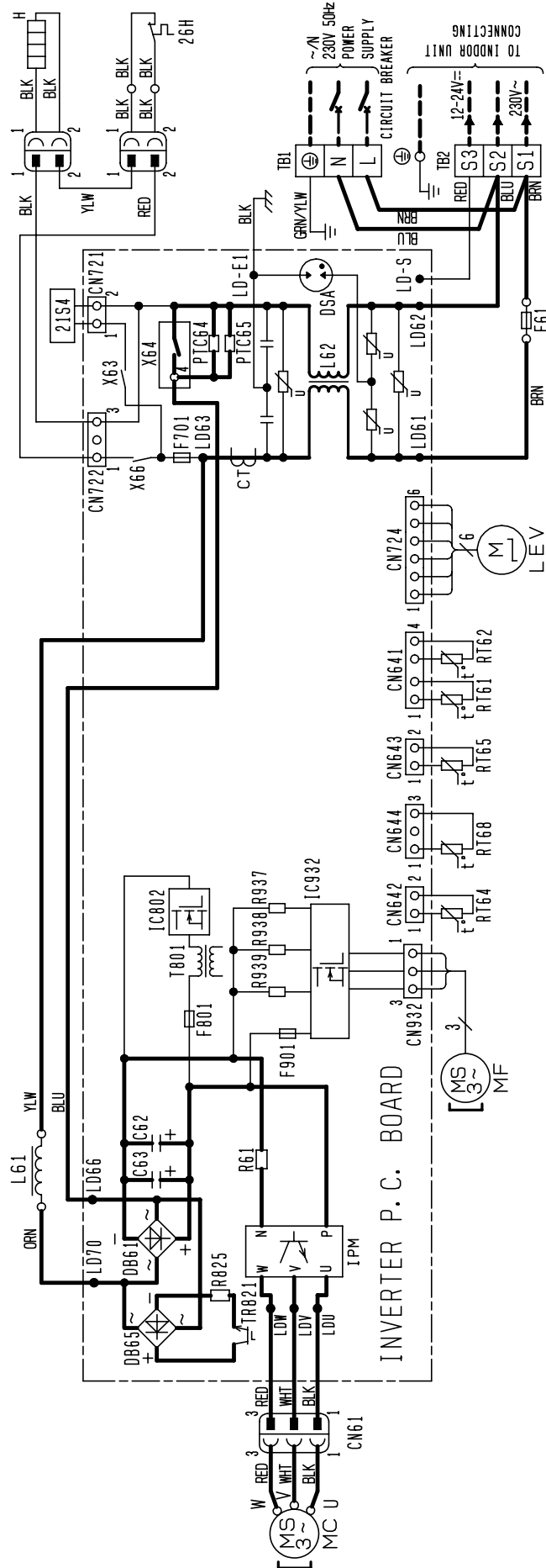

NOTES: 1. About the indoor side electric wiring, refer to the indoor unit electric wiring diagram for servicing.

2. Use copper conductors only. (For field wiring)

3. Symbols below indicate.

□ : Terminal block

SYMBOL	NAME	SYMBOL	NAME	SYMBOL	NAME
CT	CURRENT TRANSFORMER	LEV	EXPANSION VALVE COIL	R61	CURRENT-DETECTING RESISTOR
C62, C63	SMOOTHING CAPACITOR	MC	COMPRESSOR	R825, R937	CURRENT-DETECTING RESISTOR
DB61, DB65	DIODE MODULE	MF	FAN MOTOR	R938, R939	CURRENT-DETECTING RESISTOR
DSA	SURGE ABSORBER	PTC64, PTC65	CIRCUIT PROTECTION	TBL, TB2	TERMINAL BLOCK
F61	FUSE (T20AL/250V)	RT61	DEFROST THERMISTOR	TR821	SWITCHING POWER TRANSISTOR
F701, F801, F901	FUSE (T3.15AL/250V)	RT62	DISCHARGE TEMP. THERMISTOR	T801	TRANSFORMER
IC802	INTELLIGENT POWER DEVICE	RT64	FIN TEMP. THERMISTOR	X63, X64, X66	RELAY
IPM, IC932	INTELLIGENT POWER MODULE	RT65	AMBIENT TEMP. THERMISTOR	21S4	REVERSING VALVE COIL
L61	REACTOR	RT68	OUTDOOR HEAT EXCHANGER	H	DEFROST HEATER
L62	CNC COIL		TEMP. THERMISTOR.	26H	HEATER PROTECTOR

SUZ-KA50VA.TH SUZ-KA50VA<sub>1</sub>.TH  
 SUZ-KA60VA.TH SUZ-KA60VA<sub>1</sub>.TH

OUTDOOR UNIT

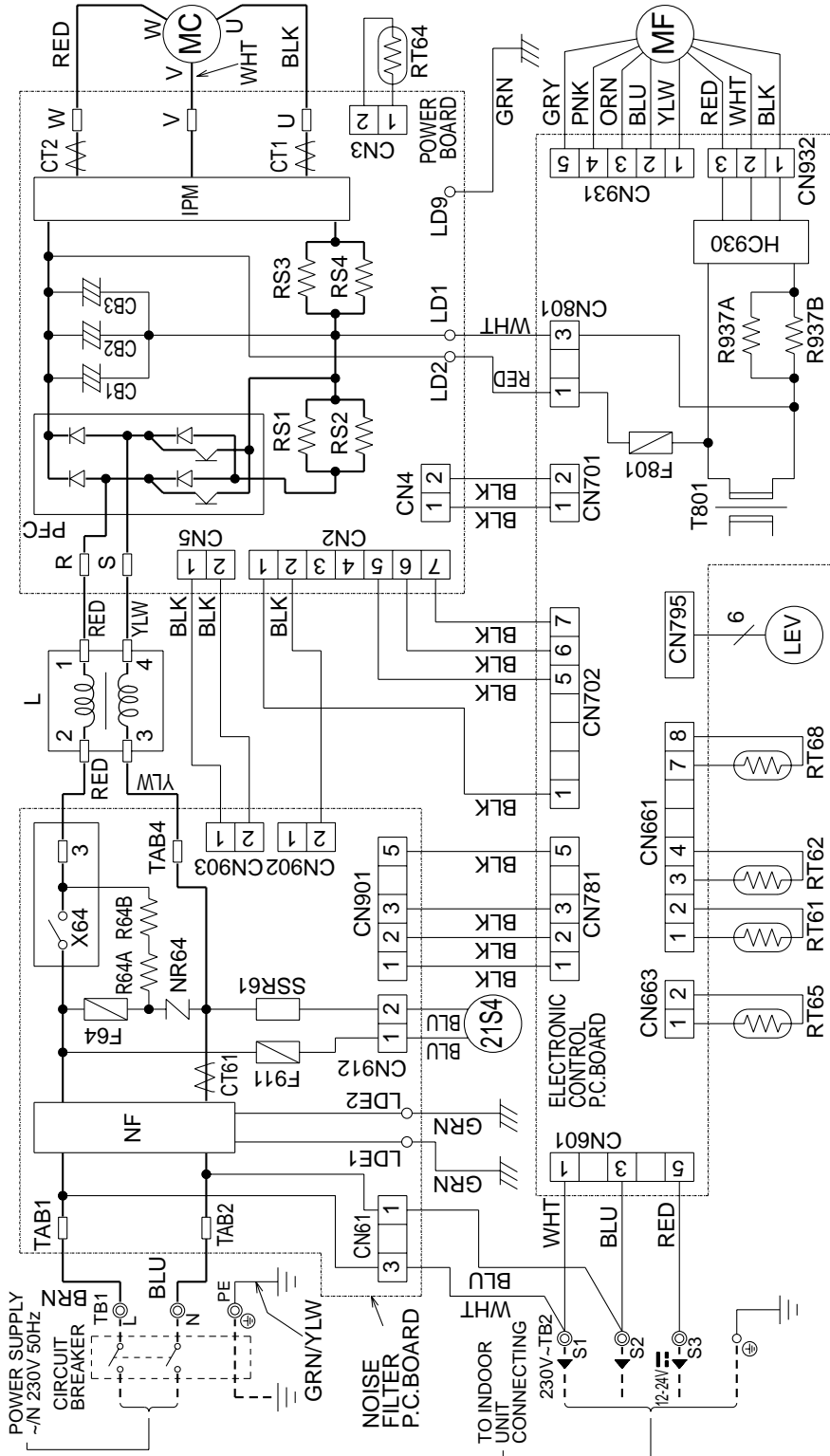

- NOTES: 1. About the indoor side electric wiring, refer to the indoor unit electric wiring diagram for servicing.  
 2. Use copper conductors only (for field wiring).  
 3. Symbols below indicate.  
 ◎: Terminal block □□: Connector

SYMBOL	NAME	SYMBOL	NAME	SYMBOL	NAME
CB1-3	SMOOTHING CAPACITOR	MC	COMPRESSOR	RT64	FIN TEMPERATURE THERMISTOR
CT1, 2	CURRENT TRANSFORMER	MF	OUTDOOR FAN MOTOR	RT65	AMBIENT TEMPERATURE THERMISTOR
CT61	CURRENT TRANSFORMER	NF	NOISE FILTER	RT68	OUTDOOR HEAT EXCHANGER TEMPERATURE THERMISTOR
F64	FUSE (T2AL 250V)	NR64	VARIABLE RESISTOR	SSR61	SOLENOID COIL RELAY
F801	FUSE (T3.15AL 250V)	R64A, B	RESISTOR	T801	TRANSFORMER
F911	FUSE (T1AL 250V)	R937A, B	RESISTOR	TB1	TERMINAL BLOCK
IPM	INTELLIGENT POWER MODULE	RS1-4	RESISTOR	TB2	TERMINAL BLOCK
L	REACTOR	RT61	DEFROST THERMISTOR	X64	RELAY
LEV	EXPANSION VALVE COIL	RT62	DISCHARGE TEMPERATURE THERMISTOR	21S4	REVERSING VALVE COIL

# SUZ-KA50VAR2.TH

## OUTDOOR UNIT

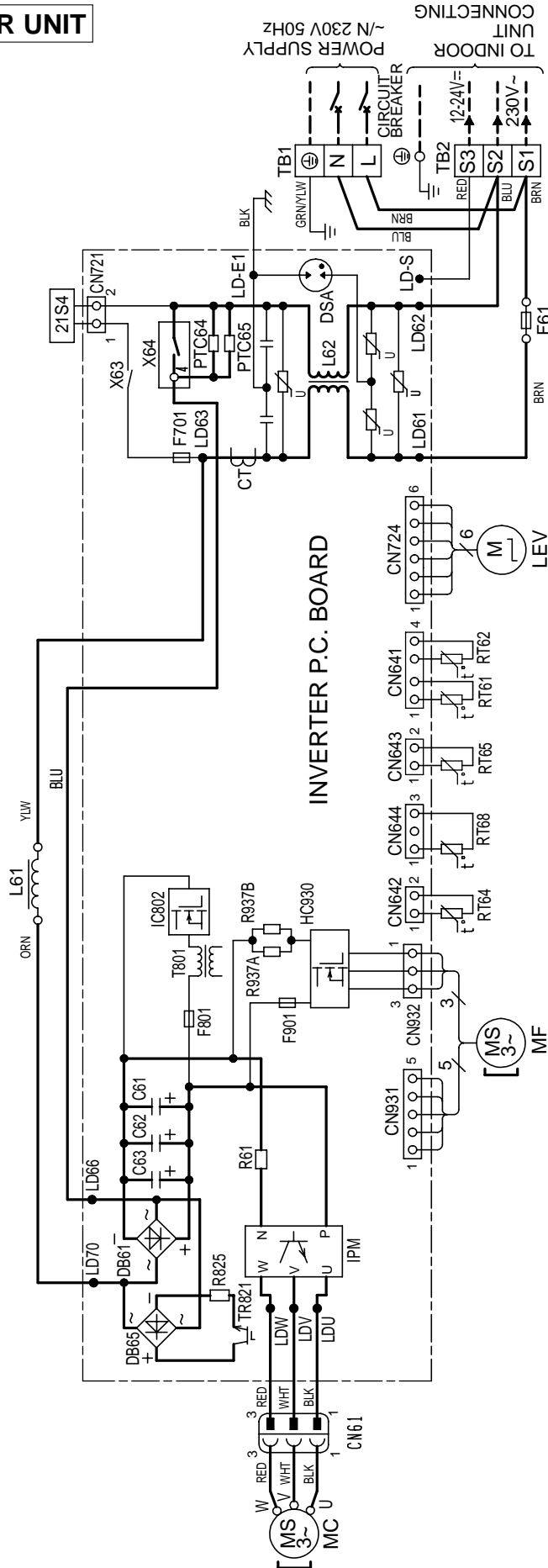

NOTES: 1. About the indoor side electric wiring, refer to the indoor unit electric wiring diagram for servicing.  
2. Use copper conductors only (for field wiring).  
3. Symbols below indicate.

SYMBOL	NAME	SYMBOL	NAME	SYMBOL	NAME
CT	CURRENT TRANSFORMER	LEV	EXPANSION VALVE COIL	R61	CURRENT-DETECTING RESISTOR
C61,62,63	SMOOTHING CAPACITOR	MC	COMPRESSOR	R825	CURRENT-DETECTING RESISTOR
DB61, DB65	DIODE MODULE	MF	FAN MOTOR	R937A, B	CURRENT-DETECTING RESISTOR
DSA	SURGE ABSORBER	PTC64, PTC65	CIRCUIT PROTECTION	TB1, TB52	TERMINAL BLOCK
F61	FUSE (T20AL 250V)	RT61	DEFROST THERMISTOR	TR821	SWITCHING POWER TRANSISTOR
F701, F801, F901	FUSE (T3.15AL 250V)	RT62	DISCHARGE TEMP. THERMISTOR	T801	TRANSFORMER
HC930, IPM	INTELLIGENT POWER MODULE	RT64	FIN TEMP. THERMISTOR	X63, X64	RELAY
IC802	INTELLIGENT POWER DEVICE	RT65	AMBIENT TEMP. THERMISTOR	21S4	REVERSING VALVE COIL
L61	REACTOR	RT68	OUTDOOR HEAT EXCHANGER TEMP. THERMISTOR		
L62	REACTOR				

# SUZ-KA60VAR2.TH

## OUTDOOR UNIT

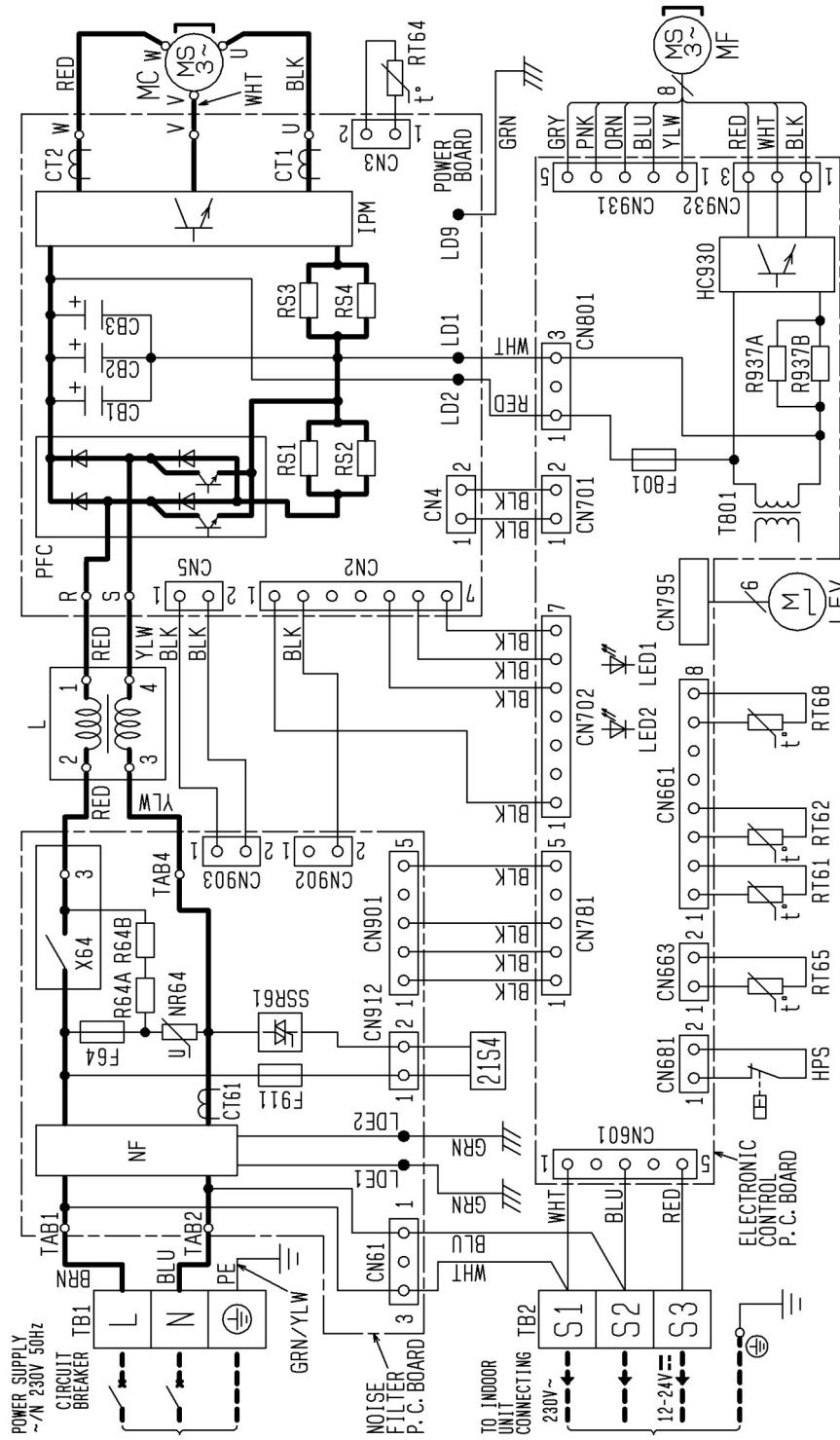

- NOTES:
1. About the indoor side electric wiring refer to the indoor unit electric wiring diagram for servicing.
  2. Use copper conductors only (for field wiring).
  3. Symbols below indicate.
    - □ □ □ : Terminal block

SYMBOL	NAME	SYMBOL	NAME	SYMBOL	NAME
CB1-3	SMOOTHING CAPACITOR	LEV	EXPANSION VALVE	RT65	AMBIENT TEMP. THERMISTOR
CT1.2	CURRENT TRANSFORMER	MC	COMPRESSOR	RT68	OUTDOOR HEAT EXCHANGER TEMP. THERMISTOR
CT61	CURRENT TRANSFORMER	MF	FAN MOTOR	R64A, B	RESISTOR
F64	FUSE (T2AL 250V)	NF	NOISE FILTER	R937A, B	RESISTOR
F801	FUSE (T3.15AL 250V)	NR64	VARIABLE	SSR61	SOLENOID COIL RELAY
F911	FUSE (T1AL 250V)	PFC	POWER FACTOR CONTROLLER	TB1	TERMINAL BLOCK
HC930	INTELLIGENT POWER MODULE	RS1-4	RESISTOR	TB2	TERMINAL BLOCK
HPS	HIGH PRESSURE SWITCH	RT61	DEFROST THERMISTOR	T801	TRANSFORMER
IPM	INTELLIGENT POWER MODULE	RT62	DISCHARGE TEMP. THERMISTOR	X64	RELAY
L	REACTOR	RT64	FIN TEMP. THERMISTOR	21S4	REVERSING VALVE COIL

SUZ-KA71VA.TH SUZ-KA71VA1.TH

OUTDOOR UNIT

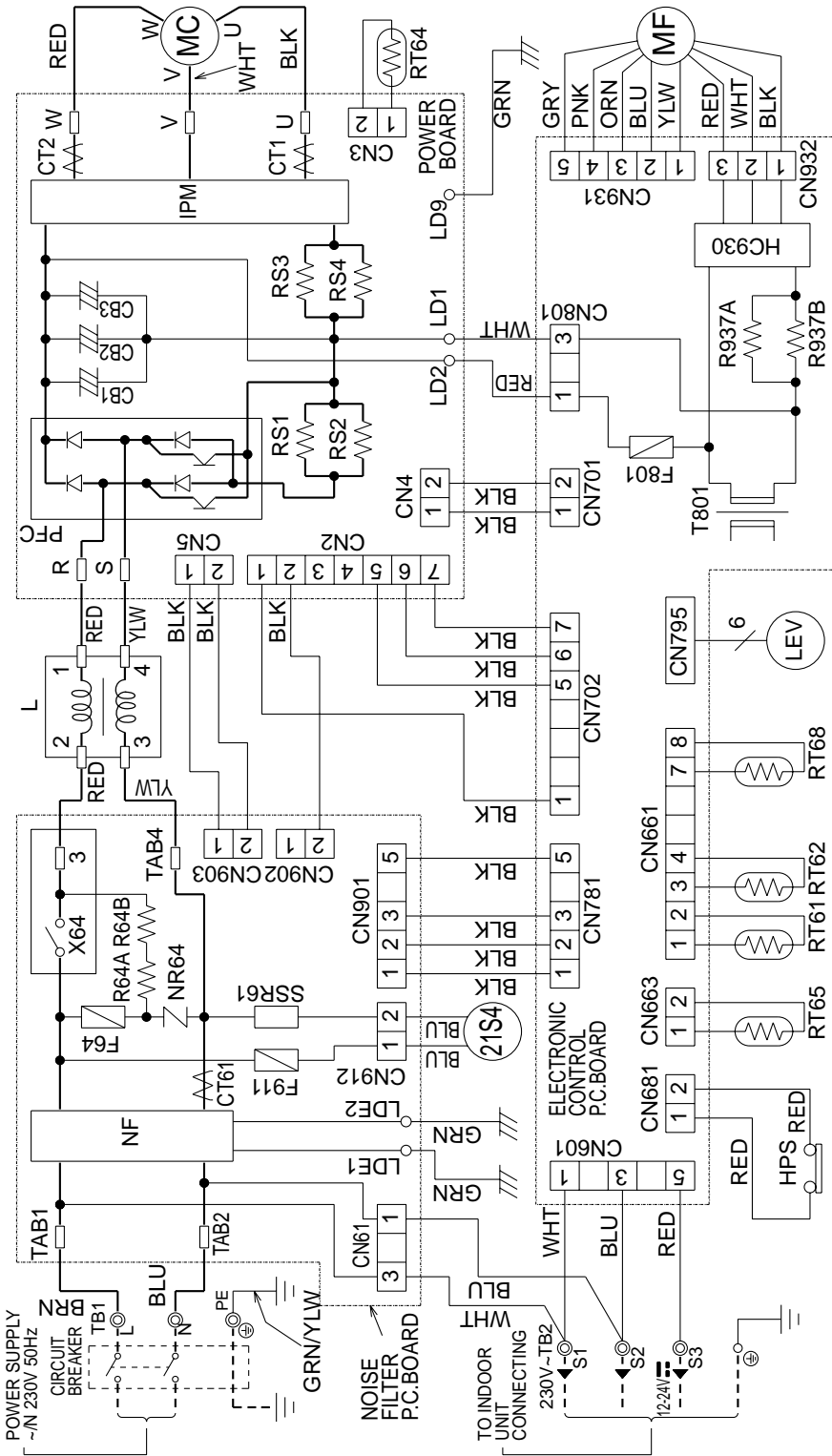

- NOTES: 1. About the indoor side electric wiring, refer to the indoor unit electric wiring diagram for servicing.  
 2. Use copper conductors only (for field wiring).  
 3. Symbols below indicate.  
 ⊙: Terminal block □: Connector

SYMBOL	NAME	SYMBOL	NAME	SYMBOL	NAME
CB1-3	SMOOTHING CAPACITOR	MC	COMPRESSOR	RT65	AMBIENT TEMPERATURE THERMISTOR
CT1, 2	CURRENT TRANSFORMER	MF	OUTDOOR FAN MOTOR	RT68	OUTDOOR HEAT EXCHANGER
CT61	CURRENT TRANSFORMER	NF	NOISE FILTER	RT69	TEMPERATURE THERMISTOR
F64	FUSE (T2AL 250V)	NR64	VARIATOR	SSR61	SOLENOID COIL RELAY
F801	FUSE (T3.15AL 250V)	PFC	POWER FACTOR CONTROLLER	T801	TRANSFORMER
F911	FUSE (T1AL 250V)	R64A, B	RESISTOR	TB1	TERMINAL BLOCK
HC930	INTELLIGENT POWER MODULE	R937A, B	RESISTOR	TB2	TERMINAL BLOCK
HPS	HIGH PRESSURE SWITCH	RS1~4	RELAY	X64	RELAY
IPM	INTELLIGENT POWER MODULE	RT61	DEFROST THERMISTOR	21S4	REVERSING VALVE COIL
L	REACTOR	RT62	DISCHARGE TEMPERATURE THERMISTOR		
LEV	EXPANSION VALVE COIL	RT64	FIN TEMPERATURE THERMISTOR		

SUZ-KA25VA.TH  
SUZ-KA25VAH.TH

Unit: mm

OUTDOOR UNIT

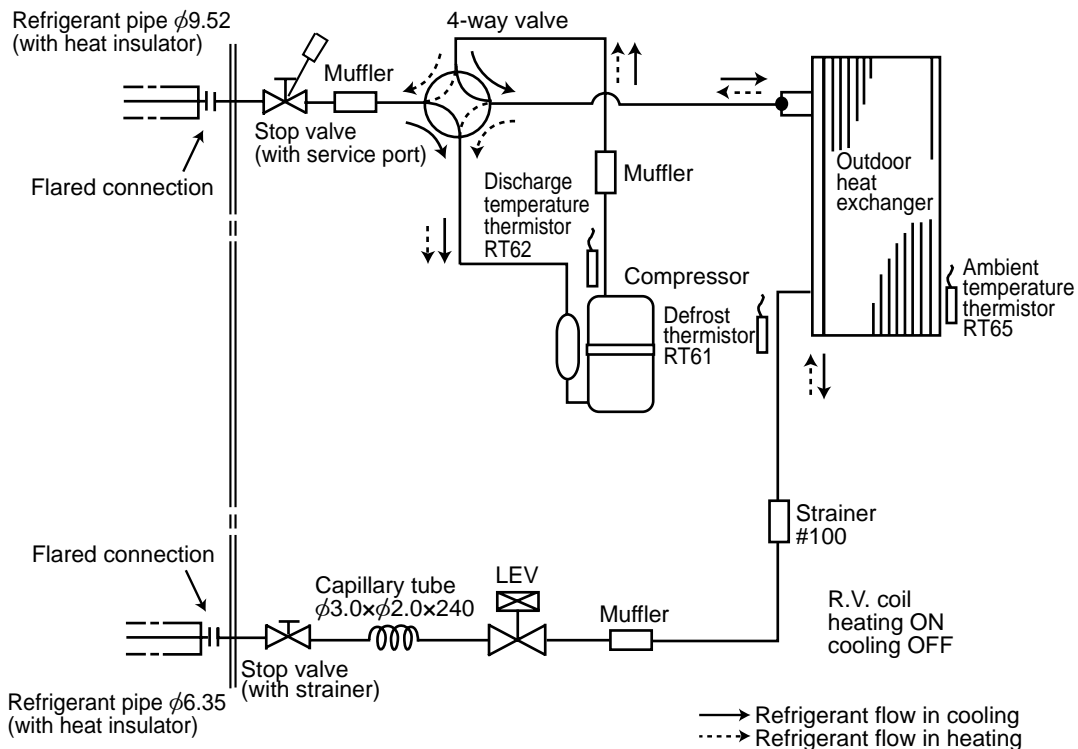

Unit: mm

SUZ-KA25VAR1.TH  
SUZ-KA25VAHR1.TH

OUTDOOR UNIT

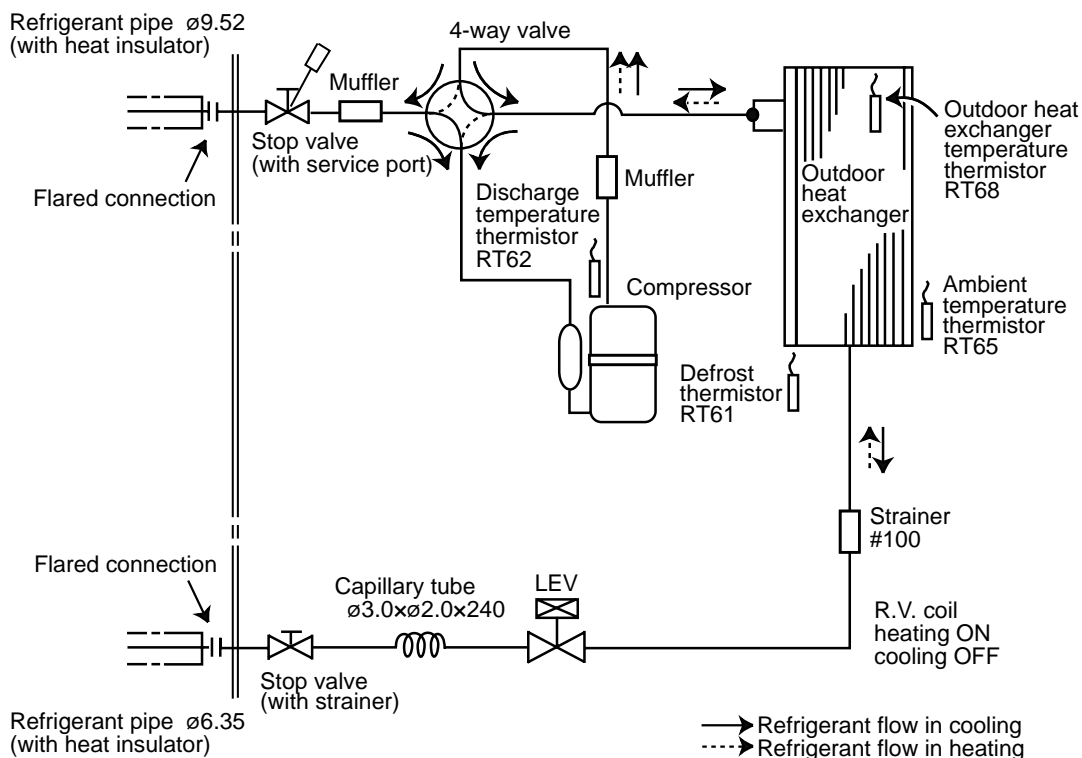

**SUZ-KA35VA.TH**  
**SUZ-KA35VAH.TH**

Unit: mm

**OUTDOOR UNIT**

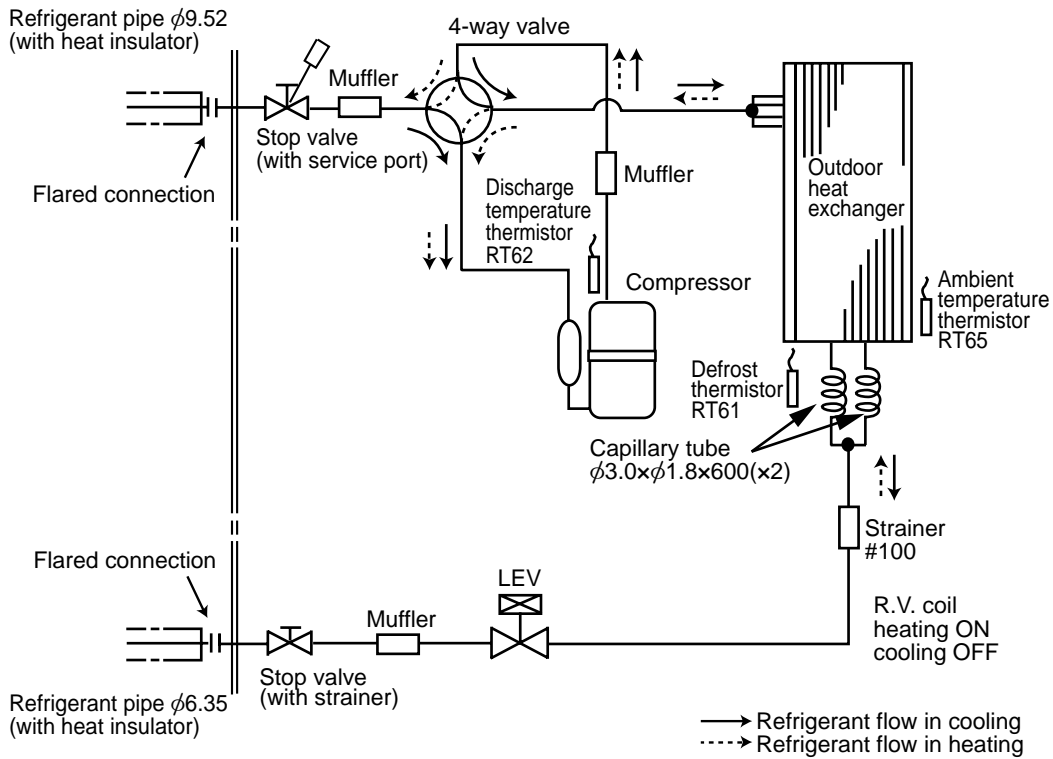

**SUZ-KA35VAR1.TH**  
**SUZ-KA35VAHR1.TH**

Unit: mm

**OUTDOOR UNIT**

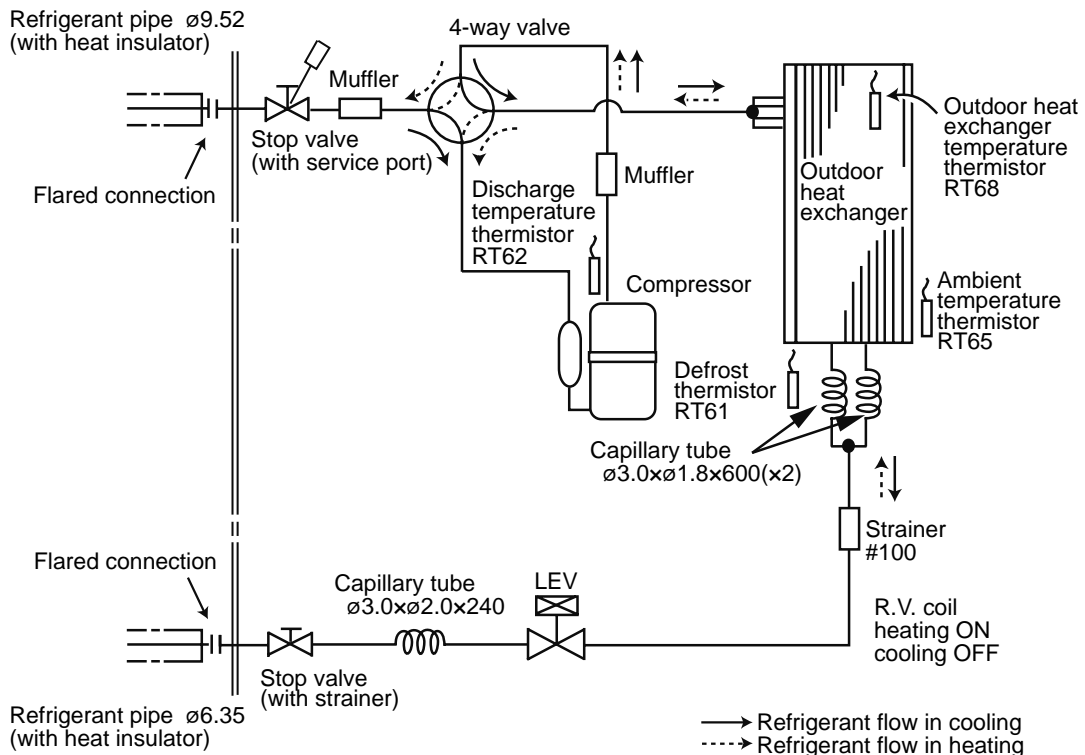



**SUZ-KA50VA.TH SUZ-KA50VA<sub>1</sub>.TH**  
**SUZ-KA60VA.TH SUZ-KA60VA<sub>1</sub>.TH**

Unit: mm

**OUTDOOR UNIT**

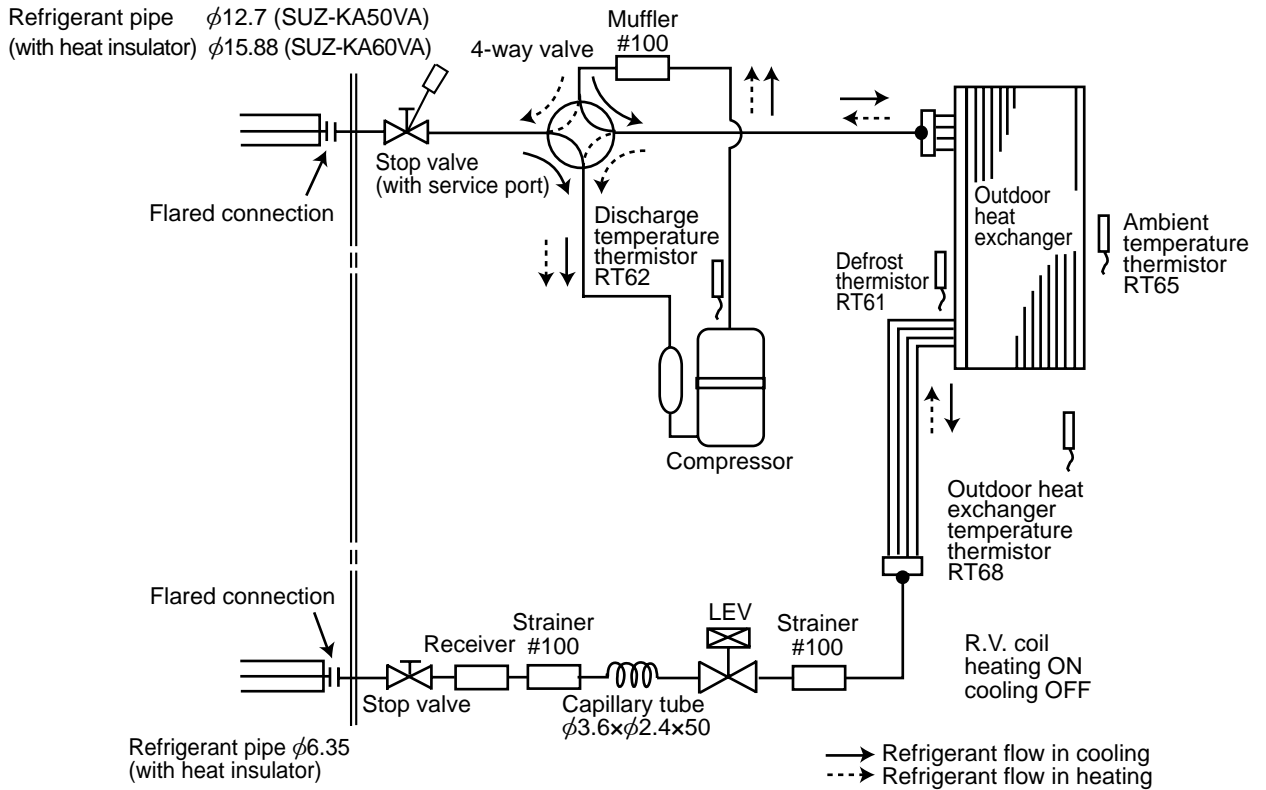

**SUZ-KA50VAR2.TH**

**OUTDOOR UNIT**

Unit: mm

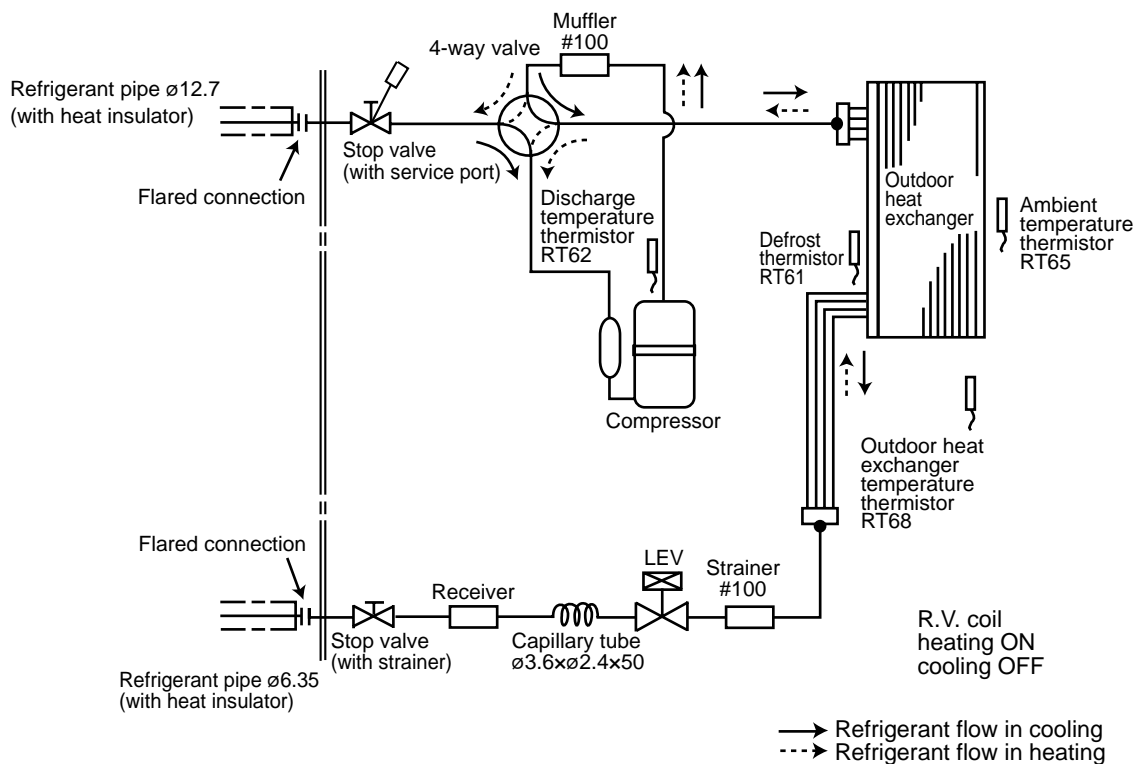

**SUZ-KA60VAR2.TH**

Unit:mm

**OUTDOOR UNIT**

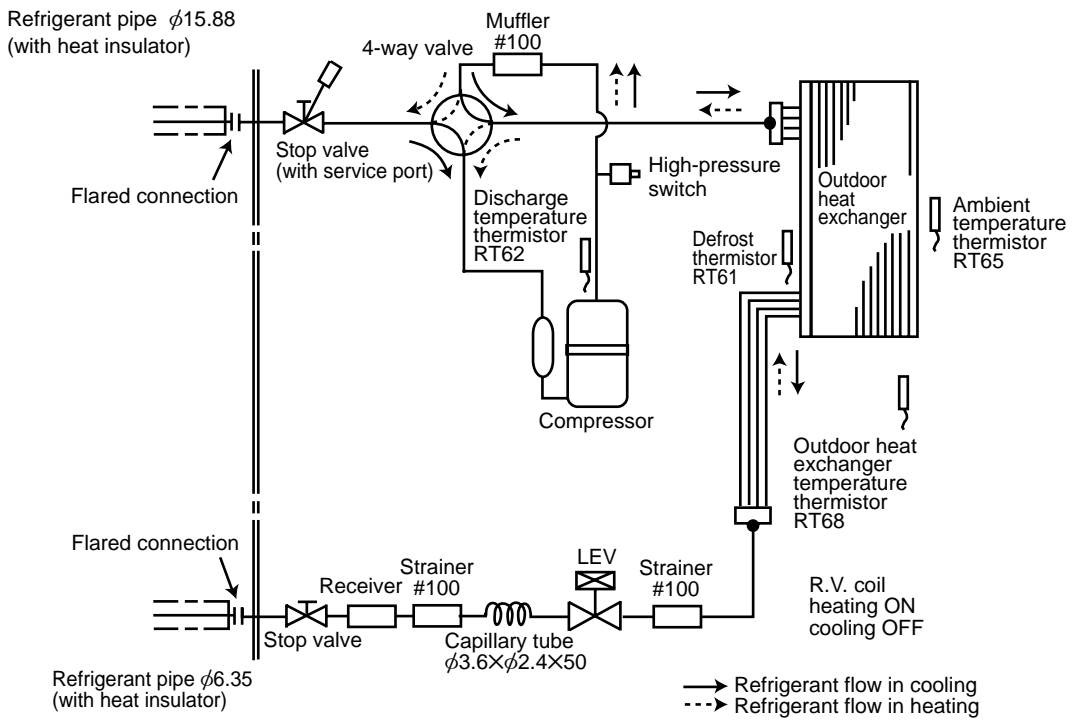

**SUZ-KA71VA.TH SUZ-KA71VA<sub>1</sub>.TH**

Unit:mm

**OUTDOOR UNIT**

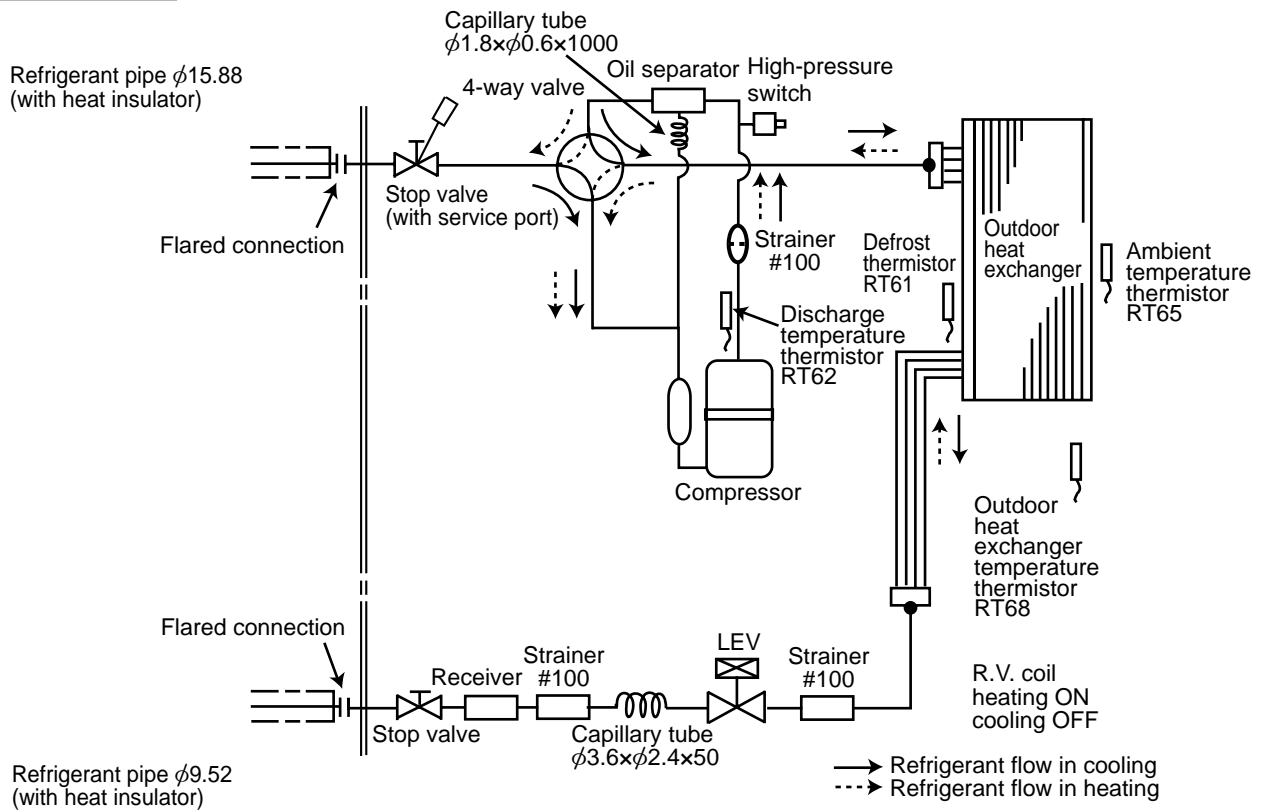

SUZ-KA25VA.TH    SUZ-KA25VAH.TH    SUZ-KA25VAR1.TH    SUZ-KA25VAHR1.TH  
 SUZ-KA35VA.TH    SUZ-KA35VAH.TH    SUZ-KA35VAR1.TH    SUZ-KA35VAHR1.TH

**MAX. REFRIGERANT PIPING LENGTH**

Models	Refrigerant piping Max. length: m A	Piping size O.D: mm	
		Gas	Liquid
SUZ-KA25VA.TH SUZ-KA35VA.TH SUZ-KA25VAH.TH SUZ-KA35VAH.TH SUZ-KA25VAR1.TH SUZ-KA35VAR1.TH SUZ-KA25VAHR1.TH SUZ-KA35VAHR1.TH	20	9.52	6.35

**MAX. HEIGHT DIFFERENCE**

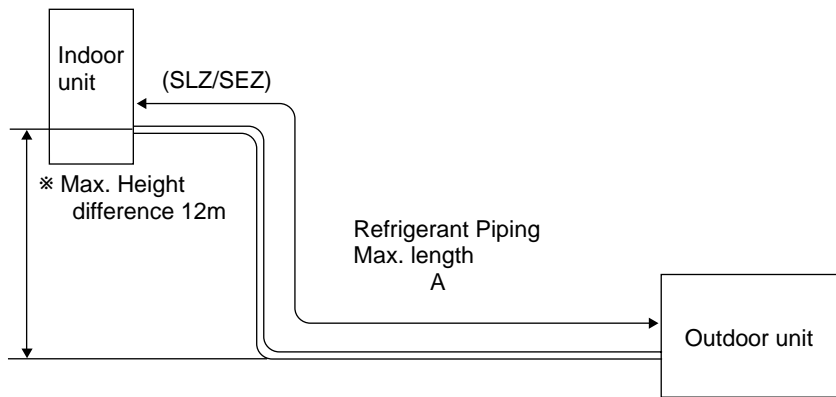

\* Height difference should be within 12m regardless of which unit, indoor or outdoor position is high.

**ADDITIONAL REFRIGERANT CHARGE (R410A: g)**

Models	Outdoor unit precharged	Refrigerant piping length (one way)											
		5m	6m	7m	8m	9m	10m	11m	12m	13m	14m	15m	20m
SUZ-KA25VA.TH SUZ-KA25VAH.TH	900	0	0	0	90	120	150	180	210	240	270	300	450
SUZ-KA25VAR1.TH SUZ-KA25VAHR1.TH	800	0	0	0	90	120	150	180	210	240	270	300	450
SUZ-KA35VA.TH SUZ-KA35VAH.TH SUZ-KA35VAR1.TH SUZ-KA35VAHR1.TH	1,050	0	0	0	90	120	150	180	210	240	270	300	450

Calculation :  $X_g = 30g/m \times (\text{Refrigerant piping length}(m) - 5)$

SUZ-KA50VA.TH SUZ-KA50VA<sub>1</sub>.TH SUZ-KA50VAR2.TH  
 SUZ-KA60VA.TH SUZ-KA60VA<sub>1</sub>.TH SUZ-KA60VAR2.TH  
 SUZ-KA71VA.TH SUZ-KA71VA<sub>1</sub>.TH

**MAX. REFRIGERANT PIPING LENGTH**

Model	Refrigerant piping Max. length: m A	Piping size O.D: mm	
		Gas	Liquid
SUZ-KA50VA.TH SUZ-KA50VA <sub>1</sub> .TH SUZ-KA50VAR2.TH	30	12.7	6.35
SUZ-KA60VA.TH SUZ-KA60VA <sub>1</sub> .TH SUZ-KA60VAR2.TH		15.88	
SUZ-KA71VA.TH SUZ-KA71VA <sub>1</sub> .TH		9.52	

**MAX. HEIGHT DIFFERENCE**

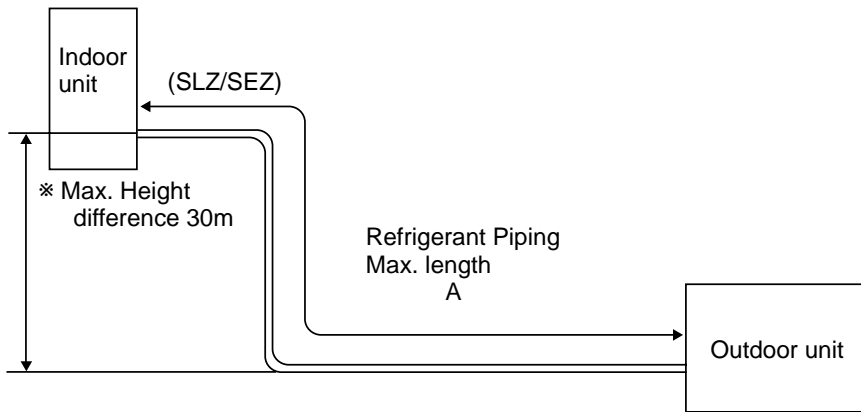

\* Height difference should be within 30m regardless of which unit, indoor or outdoor position is high.  
 Max. Height difference of SUZ-KA50/60/71VA.TH : 15m  
 SUZ-KA50/60/71VA<sub>1</sub>.TH : 30m  
 SUZ-KA50/60VAR2.TH : 30m

**ADDITIONAL REFRIGERANT CHARGE (R410A: g)**

Model	Outdoor unit precharged	Refrigerant piping length (one way)					
		7m	10m	15m	20m	25m	30m
SUZ-KA50VA.TH SUZ-KA50VA <sub>1</sub> .TH SUZ-KA50VAR2.TH	1,600	0	60	160	260	360	460
SUZ-KA60VA.TH SUZ-KA60VA <sub>1</sub> .TH SUZ-KA60VAR2.TH	1,800	0	60	160	260	360	460

Calculation :  $X_g = 20g/m \times (\text{Refrigerant piping length}(m) - 7)$

Model	Outdoor unit precharged	Refrigerant piping length (one way)					
		7m	10m	15m	20m	25m	30m
SUZ-KA71VA.TH SUZ-KA71VA <sub>1</sub> .TH	2,000	0	165	440	715	990	1,265

Calculation :  $X_g = 55g/m \times (\text{Refrigerant piping length}(m) - 7)$

**Model**

- SLZ-KA25VA(L)/SUZ-KA25VA
- SLZ-KA35VA(L)/SUZ-KA35VA
- SLZ-KA50VA(L)/SUZ-KA50VA

The standard data contained in these specifications applies only to the operation of the air conditioner under normal condition. Operating conditions vary according to the areas where these units are installed. The following information has been provided to clarify the operating characteristics of the air conditioner under the conditions indicated by the performance curve.

**(1) GUARANTEED VOLTAGE**

Rated voltage:  $\pm 10\%$  (207~253V), 50Hz

**(2) AIR FLOW**

Air flow should be set at MAX.

**(3) MAIN READINGS****COOLING**

- |  |  |
|--|--|
| (1) Indoor intake air wet-bulb temperature: W.B. °C  | (1) Indoor intake air dry-bulb temperature: D.B. °C  |
| (2) Indoor outlet air wet-bulb temperature: W.B. °C  | (2) Indoor outlet air dry-bulb temperature: D.B. °C  |
| (3) Outdoor intake air dry-bulb temperature: D.B. °C | (3) Outdoor intake air wet-bulb temperature: W.B. °C |
| (4) Total input: W                                   | (4) Total input: W                                   |

**HEATING**

Indoor air wet/dry-bulb temperature difference on the side of the chart on page shows the difference between the indoor intake air wet/dry-bulb temperature and the indoor outlet air wet/dry-bulb temperature for your reference at service.

**How to measure the indoor air wet-bulb/dry-bulb temperature difference**

1. Attach at least 2 sets of wet-and-dry-bulb thermometers to the indoor air inlet as shown in the figure, and at least 2 sets of wet-and-dry-bulb thermometers to the indoor air outlet. The thermometers must be attached to the position where air speed is high.
2. Attach at least 2 sets of wet-and-dry-bulb thermometers to the outdoor air inlet.  
Cover the thermometers to prevent direct rays of the sun.
3. Check that the air filter is cleaned.
4. Open windows and doors of the room.
5. Press the EMERGENCY OPERATION switch once to start the EMERGENCY COOL (HEAT) MODE.
6. When system stabilizes after more than 15 minutes, measure temperature and take an average temperature.
7. 10 minutes later, measure temperature again and check that the temperature does not change.

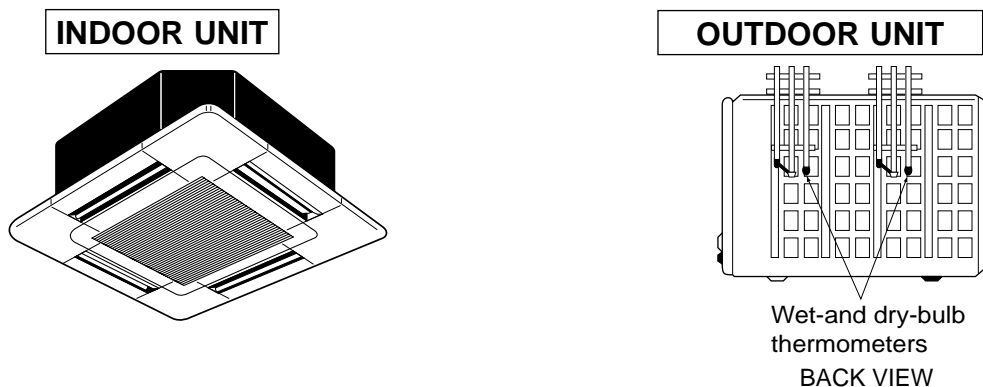

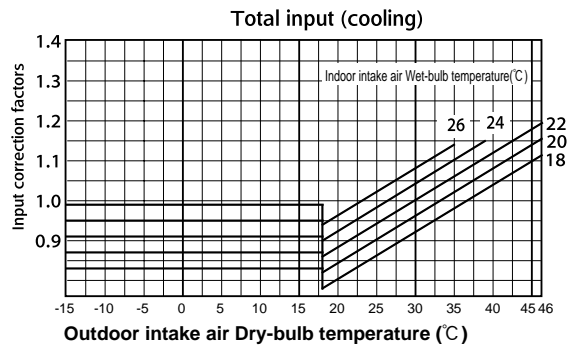
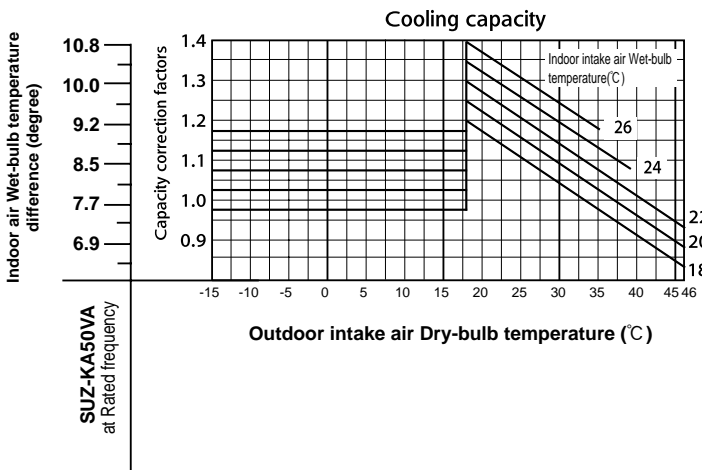
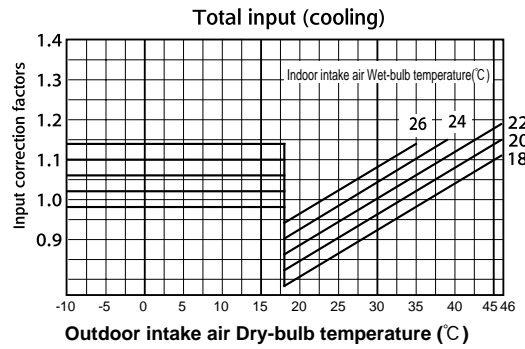
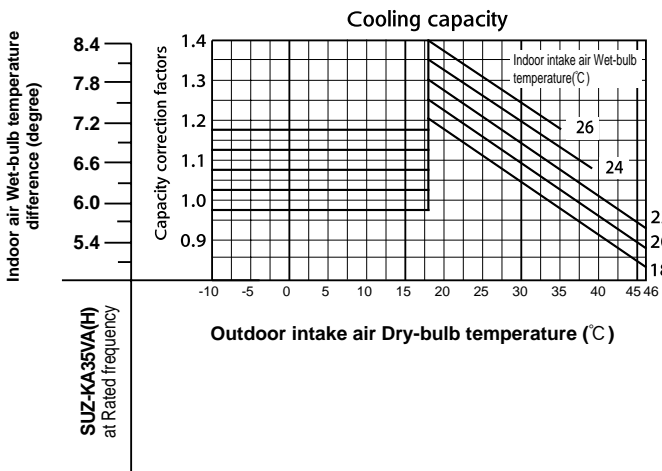
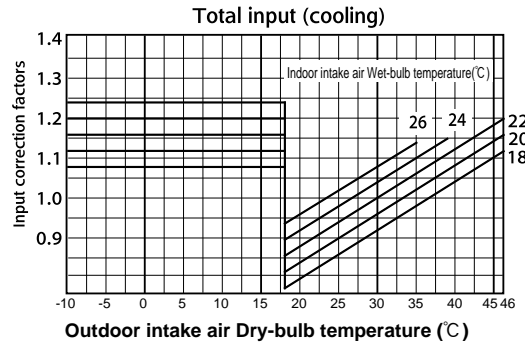
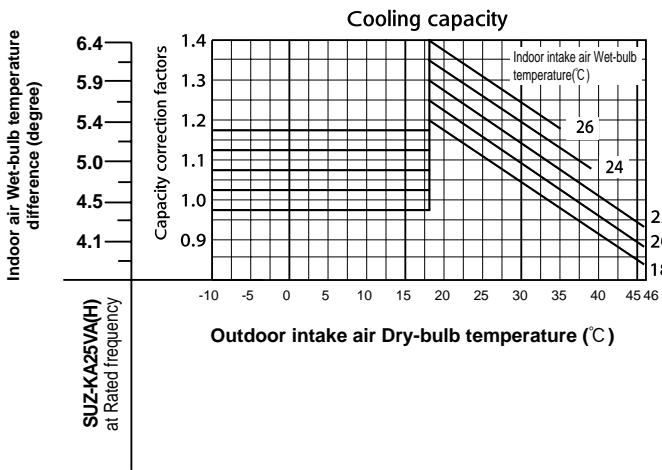

Indoor air Dry-bulb temperature difference (degree)	20.8	23.9	28.2
	19.2	22.1	26.0
	17.6	20.2	23.9
	16.0	18.4	21.7
	14.4	16.5	19.5
	12.8	14.7	17.4
	11.2	12.9	15.2
	9.6	11.0	13.0
	SUZ-KA25VA(H) at Rated frequency	SUZ-KA35VA(H) at Rated frequency	SUZ-KA50VA at Rated frequency

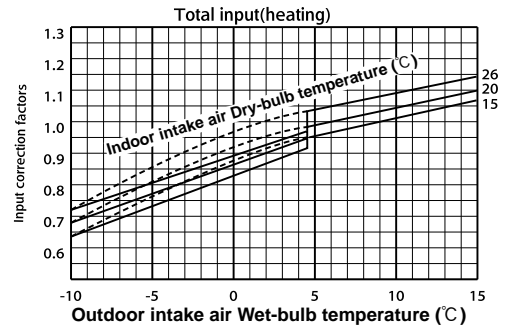
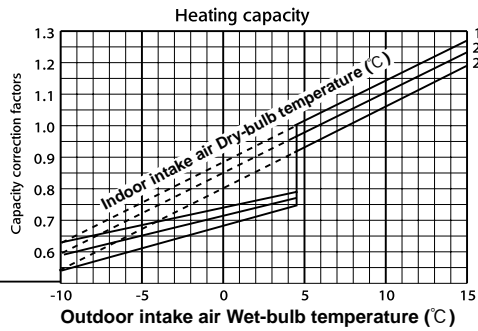

NOTE: The above curves are for the heating operation without any frost.

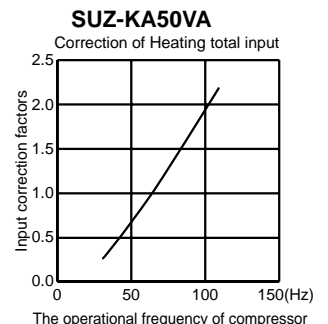
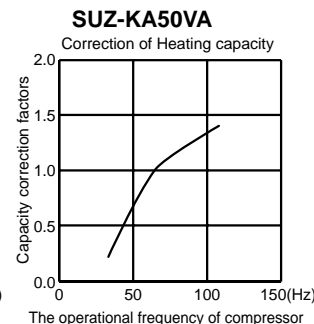
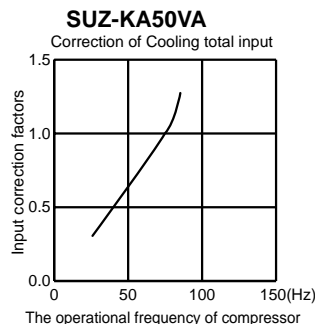
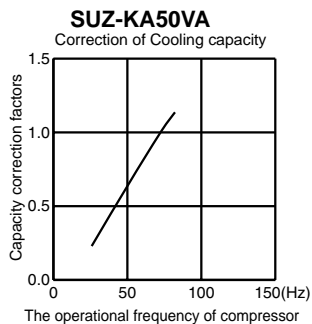
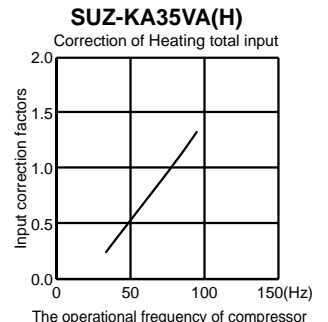
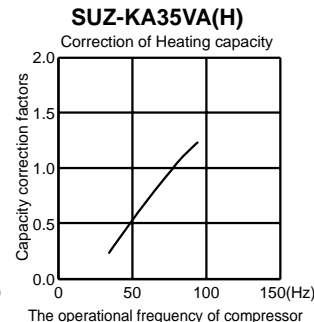
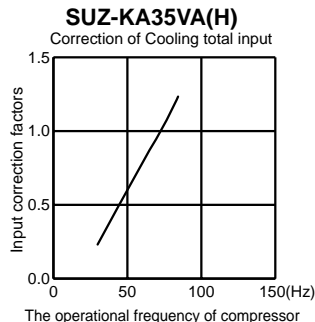
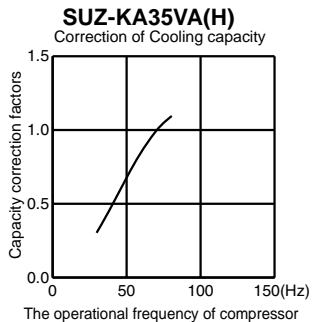
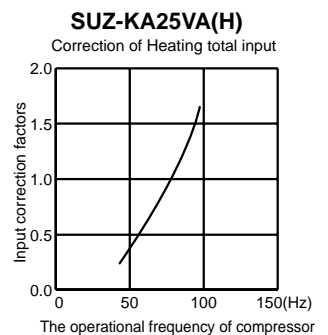
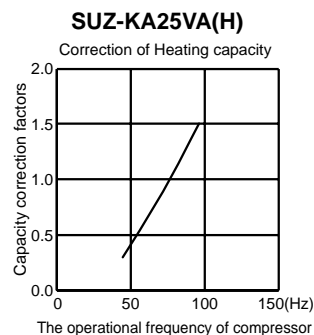
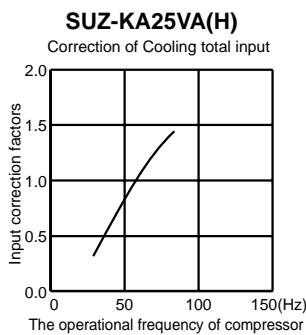
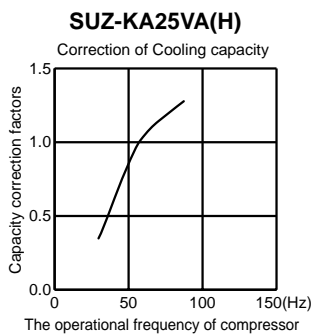

## OUTDOOR LOW PRESSURE AND OUTDOOR UNIT CURRENT

<How to operate fixed-frequency operation (Test run operation)>

1. Press the EMERGENCY OPERATION switch or the Test button to COOL or HEAT mode.
2. Test run operation starts and continues to operate for 30 minutes.
3. Compressor starts at rated frequency in COOL mode or 58Hz in HEAT mode.
4. Indoor fan operates at High speed.
5. After 30 minutes, test run operation finishes and EMERGENCY OPERATION starts.
6. To cancel test run operation (EMERGENCY OPERATION), press the EMERGENCY OPERATION switch or the ON/OFF button on remote controller.

NOTE : The unit of pressure has been changed to MPa on the international system of units (SI unit system).  
The conversion factor is: 1 (MPa [Gauge]) =10.2 (kgf/cm<sup>2</sup> [Gauge])

## OUTDOOR LOW PRESSURE AND OUTDOOR UNIT CURRENT

### COOL operation

- ① Both indoor and outdoor units are under the same temperature/humidity condition.
- ② Air flow : High speed
- ③ Operation: TEST RUN OPERATION

Dry-bulb temperature	Relative humidity(%)
20	50
25	60
30	70

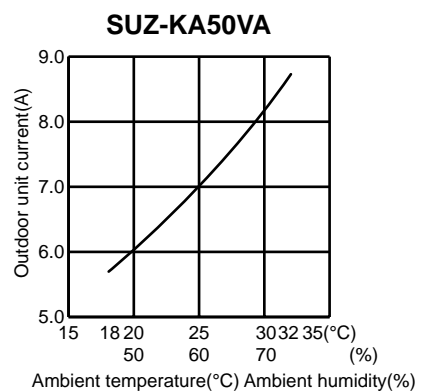
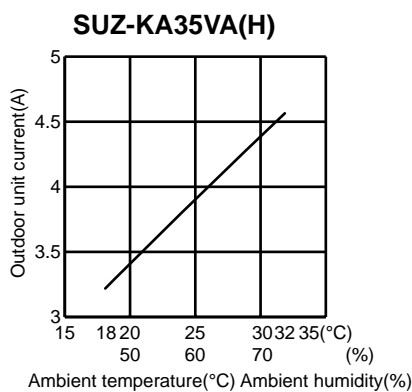
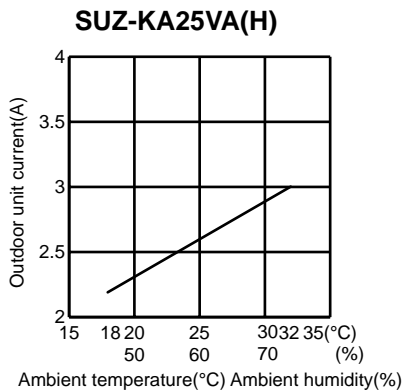
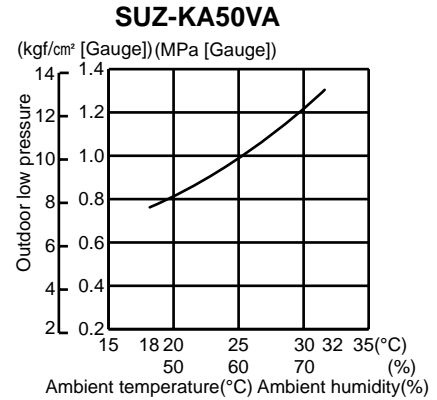
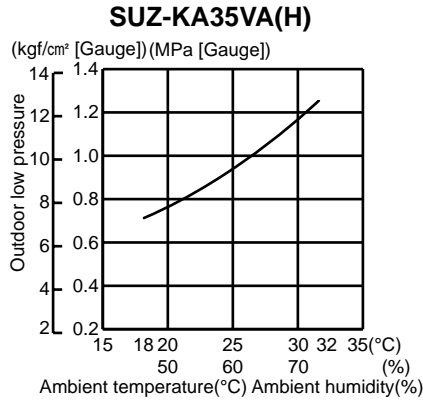
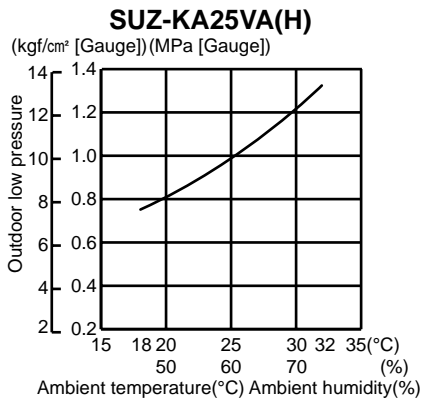

### HEAT operation

- Condition indoor: Dry bulb temperature 20.0°C  
Wet bulb temperature 14.5°C
- Condition outdoor: Dry bulb temperature 2,7,15,20.0°C  
Wet bulb temperature 1,6,12,14.5°C

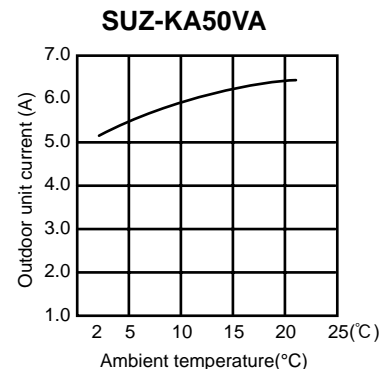
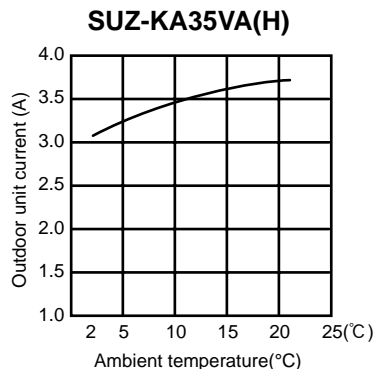
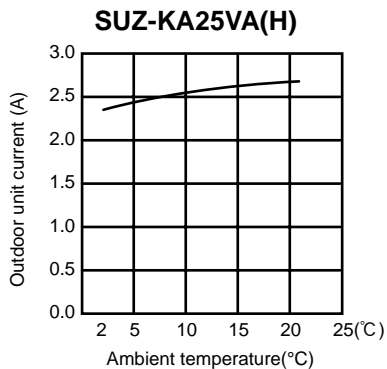



## Model

- SEZ-KC25VA/SUZ-KA25VA
- SEZ-KA35VA/SUZ-KA35VA
- SEZ-KA50VA/SUZ-KA50VA
- SEZ-KA60VA/SUZ-KA60VA
- SEZ-KA71VA/SUZ-KA71VA

The standard data contained in these specifications applies only to the operation of the air conditioner under normal condition. Operating conditions vary according to the areas where these units are installed. The following information has been provided to clarify the operating characteristics of the air conditioner under the conditions indicated by the performance curve.

### (1) GUARANTEED VOLTAGE

Rated voltage:  $\pm 10\%$  (207~253V), 50Hz

### (2) AIR FLOW

Air flow should be set at MAX.

### (3) MAIN READINGS

#### COOLING

- (1) Indoor intake air wet-bulb temperature: W.B.°C
- (2) Indoor outlet air wet-bulb temperature: W.B.°C
- (3) Outdoor intake air dry-bulb temperature: D.B.°C
- (4) Total input: W

#### HEATING

- (1) Indoor intake air dry-bulb temperature: D.B.°C
- (2) Indoor outlet air dry-bulb temperature: D.B.°C
- (3) Outdoor intake air wet-bulb temperature: W.B.°C
- (4) Total input: W

Indoor air wet/dry-bulb temperature difference on the side of the chart on page shows the difference between the indoor intake air wet/dry-bulb temperature and the indoor outlet air wet/dry-bulb temperature for your reference at service.

### How to measure the indoor air wet-bulb/dry-bulb temperature difference

1. Attach at least 2 sets of wet-and-dry-bulb thermometers to the indoor air inlet as shown in the figure, and at least 2 sets of wet-and-dry-bulb thermometers to the indoor air outlet. The thermometers must be attached to the position where air speed is high.
2. Attach at least 2 sets of wet-and-dry-bulb thermometers to the outdoor air inlet. Cover the thermometers to prevent direct rays of the sun.
3. Check that the air filter is cleaned.
4. Open windows and doors of the room.
5. Press the TEST button twice to start the COOL (HEAT) MODE.
6. When system stabilizes after more than 15 minutes, measure temperature and take an average temperature.
7. 10 minutes later, measure temperature again and check that the temperature does not change.

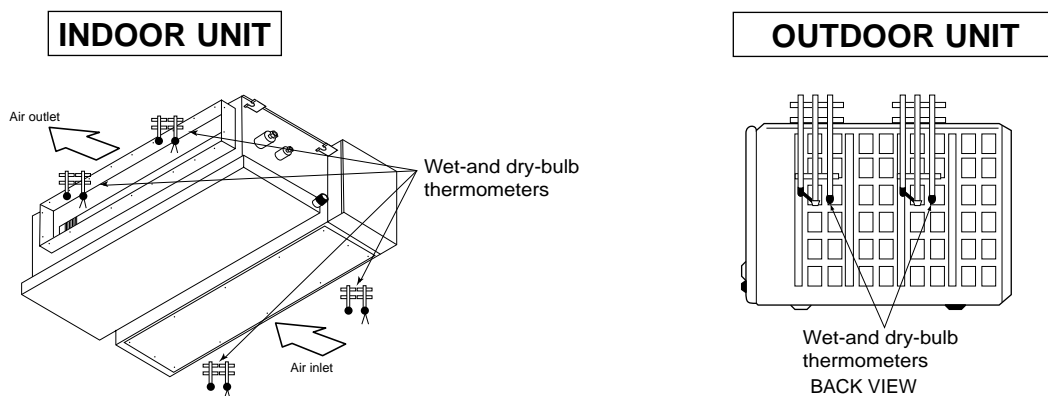

\* The picture is SEZ-KA35, 50, 60, 71VA.  
SEZ-KC25VA is similar to SEZ-KA35, 50, 60, 71VA.

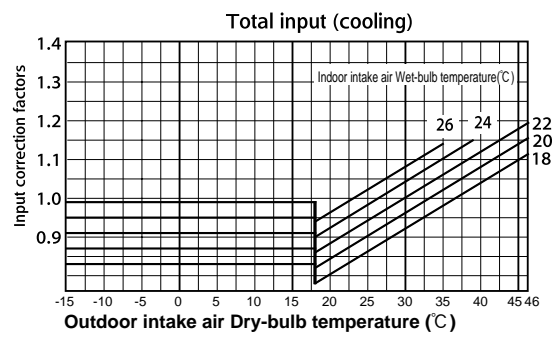
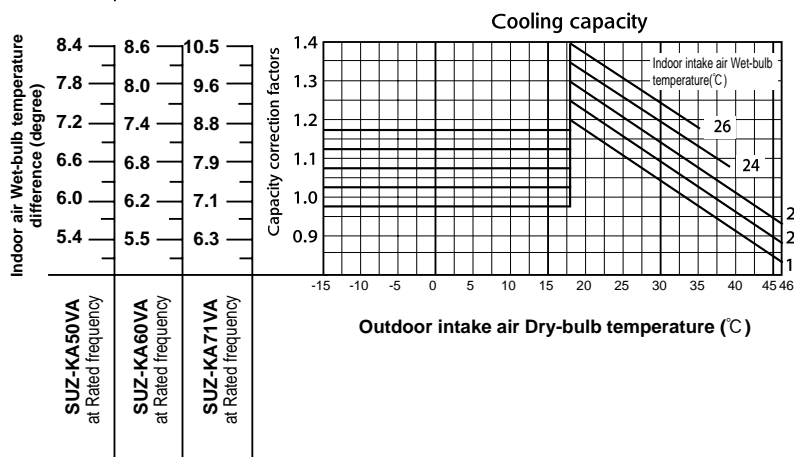
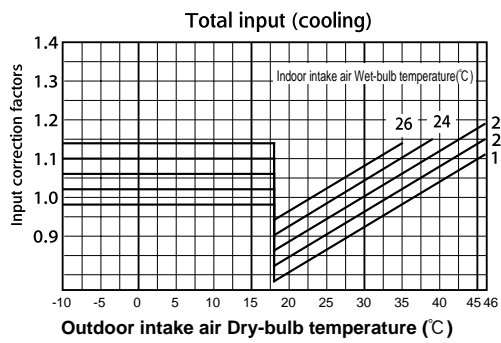
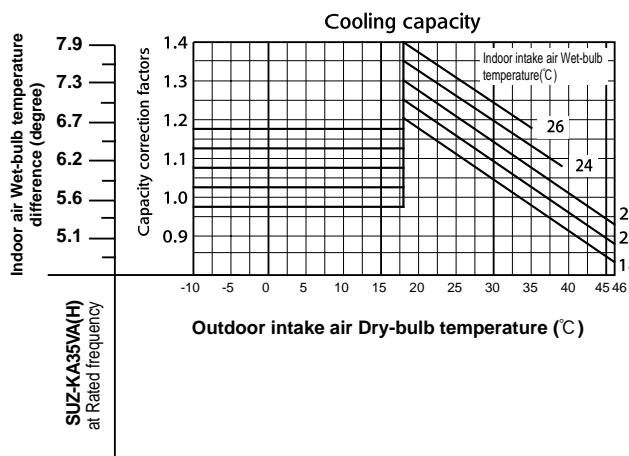
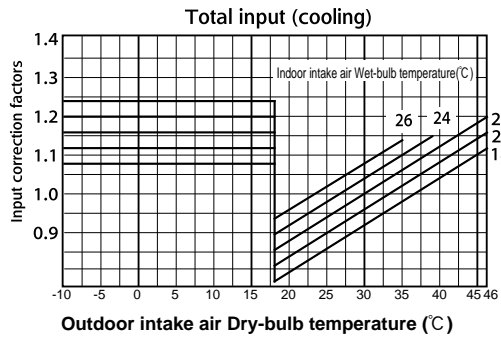
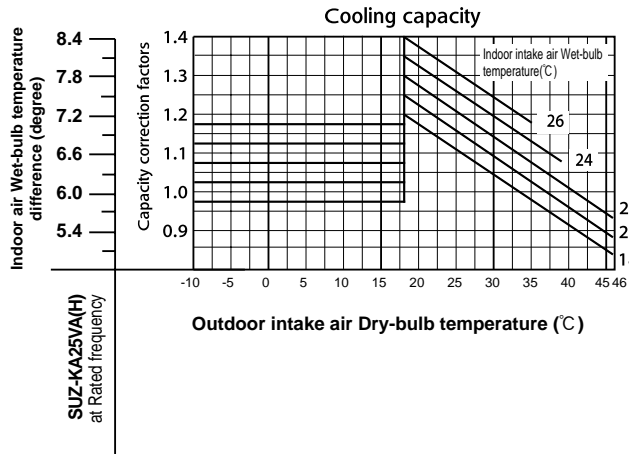

Indoor air Dry-bulb temperature difference (degree)	25.2	22.7	24.5	25.3
	23.2	20.9	22.6	23.3
	21.3	19.2	20.7	21.4
	19.4	17.4	18.9	19.4
	17.4	15.7	17.0	17.5
	15.5	14.0	15.1	15.5
	13.6	12.2	13.2	13.6
	11.6	10.5	11.3	11.7
<b>SUZ-KA25VA(H)</b> at Rated frequency				
<b>SUZ-KA35VA(H)</b> at Rated frequency				
<b>SUZ-KA50VA</b> at Rated frequency				
<b>SUZ-KA60VA</b> at Rated frequency				

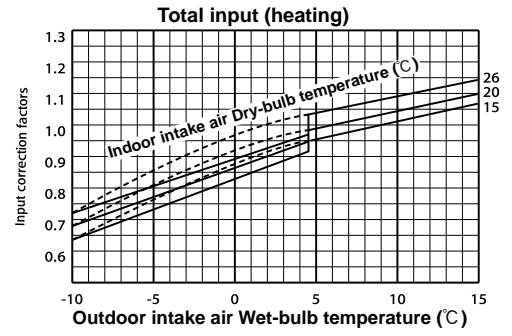
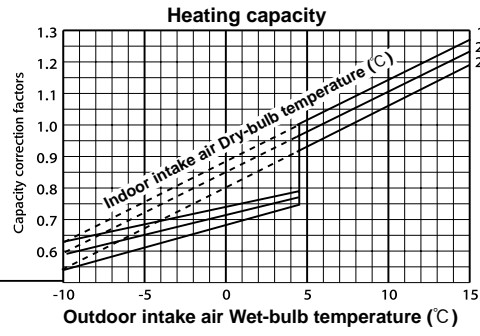

Indoor air Dry-bulb temperature difference (degree)	25.3
	23.3
	21.4
	19.4
	17.5
	15.5
	13.6
	11.7
<b>SUZ-KA71VA</b> at Rated frequency	

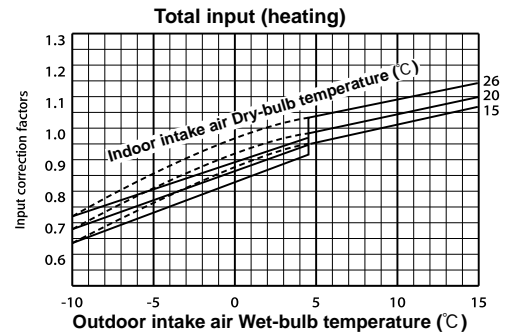
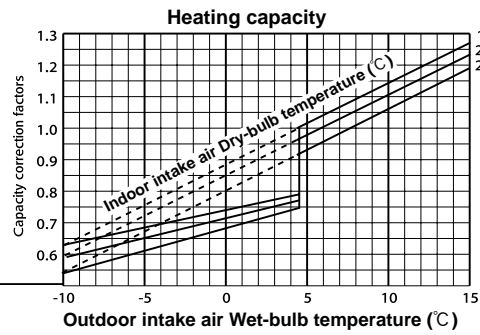

NOTE: The above curves are for the heating operation without any frost.



## OUTDOOR LOW PRESSURE AND OUTDOOR UNIT CURRENT

<How to operate fixed-frequency operation (Test run operation)>

1. Press the TEST button to COOL or HEAT mode.
2. Test run operation starts and continues to operate for 30 minutes.
3. Compressor starts at rated frequency in COOL mode or 58Hz in HEAT mode.
4. Indoor fan operates at High speed.
5. After 30 minutes, test run operation finishes and EMERGENCY OPERATION starts.
6. To cancel test run operation (EMERGENCY OPERATION), press the ON/OFF button on remote controller.

**NOTE** : The unit of pressure has been changed to MPa on the international system of units (SI unit system).

The conversion factor is: **1 (MPa [Gauge]) =10.2 (kgf/cm<sup>2</sup> [Gauge])**

## OUTDOOR LOW PRESSURE AND OUTDOOR UNIT CURRENT

### COOL operation

- ① Both indoor and outdoor units are under the same temperature/humidity condition.
- ② Air flow : High speed
- ③ Operation: TEST RUN OPERATION

Dry-bulb temperature	Relative humidity(%)
20	50
25	60
30	70

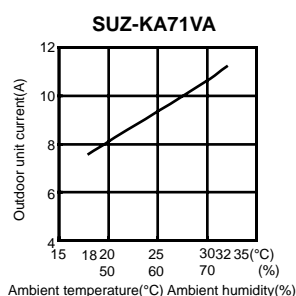
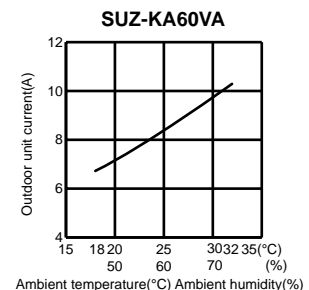
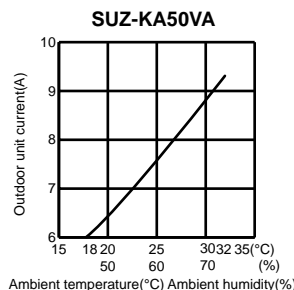
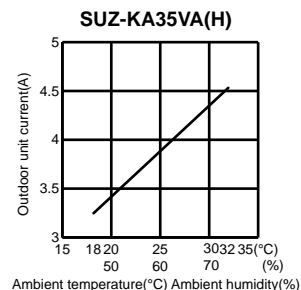
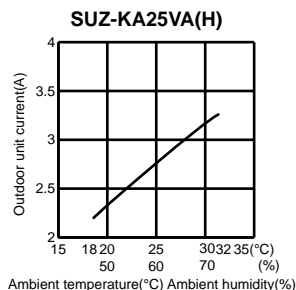
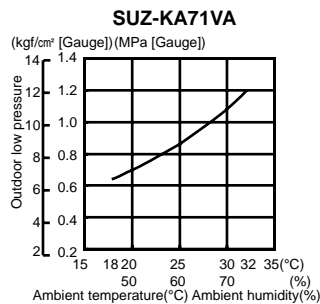
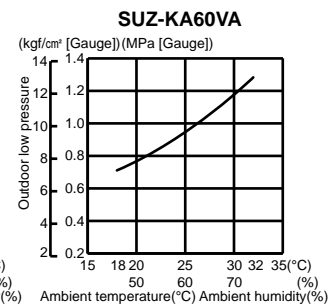
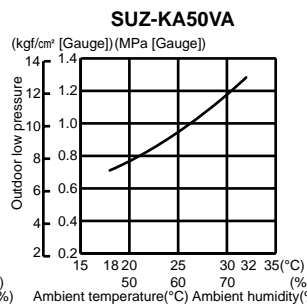
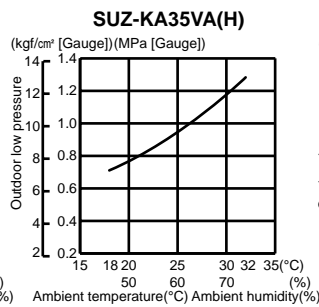
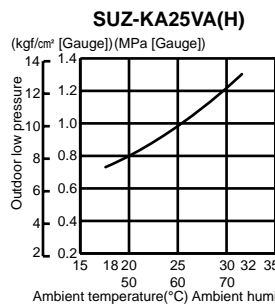

## HEAT operation

Condition indoor: Dry bulb temperature 20.0°C  
Wet bulb temperature 14.5°C

Condition outdoor: Dry bulb temperature 2,7,15,20.0°C  
Wet bulb temperature 1,6,12,14.5°C

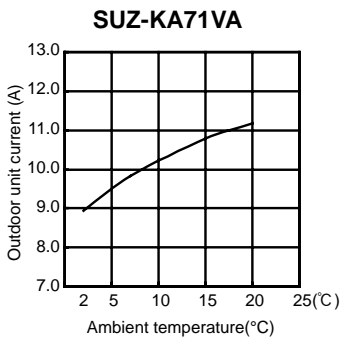
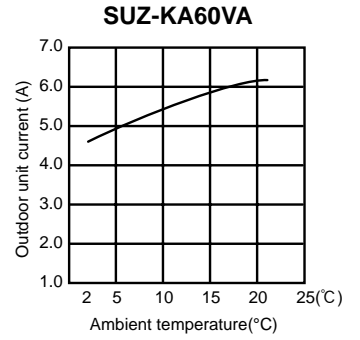
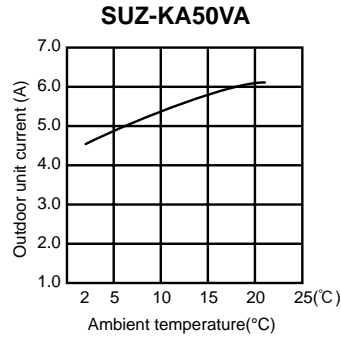
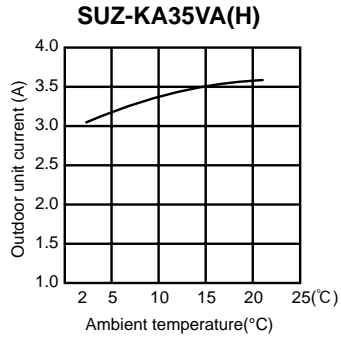
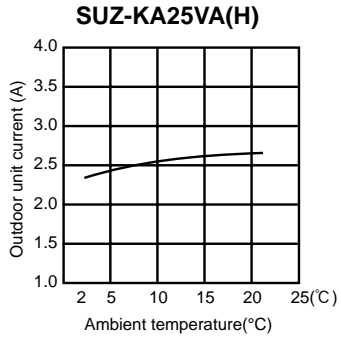

**PERFORMANCE DATA**

**COOLING operation at Rated frequency**

**SLZ-KA25VA(L)/SUZ-KA25VA(H)**

CAPACITY : 2.5(kW) INPUT : 690(W) SHF : 0.86

		OUTDOOR D.B.(°C)															
INDOOR D.B.(°C)	INDOOR W.B.(°C)	21				25				27				30			
		Q	SHC	SHF	INPUT	Q	SHC	SHF	INPUT	Q	SHC	SHF	INPUT	Q	SHC	SHF	INPUT
21	18	2.94	2.00	0.68	552	2.81	1.91	0.68	580	2.70	1.84	0.68	607	2.60	1.77	0.68	635
21	20	3.06	1.72	0.56	580	2.94	1.65	0.56	614	2.85	1.60	0.56	628	2.75	1.54	0.56	656
22	18	2.94	2.12	0.72	552	2.81	2.03	0.72	580	2.70	1.94	0.72	607	2.60	1.87	0.72	635
22	20	3.06	1.84	0.60	580	2.94	1.76	0.60	614	2.85	1.71	0.60	628	2.75	1.65	0.60	656
22	22	3.19	1.53	0.48	600	3.08	1.48	0.48	638	3.00	1.44	0.48	656	2.88	1.38	0.48	683
23	18	2.94	2.23	0.76	552	2.81	2.14	0.76	580	2.70	2.05	0.76	607	2.60	1.98	0.76	635
23	20	3.06	1.96	0.64	580	2.94	1.88	0.64	614	2.85	1.82	0.64	628	2.75	1.76	0.64	656
23	22	3.19	1.66	0.52	600	3.08	1.60	0.52	638	3.00	1.56	0.52	656	2.88	1.50	0.52	683
24	18	2.94	2.35	0.80	552	2.81	2.25	0.80	580	2.70	2.16	0.80	607	2.60	2.08	0.80	635
24	20	3.06	2.08	0.68	580	2.94	2.00	0.68	614	2.85	1.94	0.68	628	2.75	1.87	0.68	656
24	22	3.19	1.79	0.56	600	3.08	1.72	0.56	638	3.00	1.68	0.56	656	2.88	1.61	0.56	683
24	24	3.35	1.47	0.44	628	3.23	1.42	0.44	662	3.15	1.39	0.44	683	3.05	1.34	0.44	718
25	20	3.06	2.21	0.72	580	2.94	2.12	0.72	614	2.85	2.05	0.72	628	2.75	1.98	0.72	656
25	22	3.19	1.91	0.60	600	3.08	1.85	0.60	638	3.00	1.80	0.60	656	2.88	1.73	0.60	683
25	24	3.35	1.61	0.48	628	3.23	1.55	0.48	662	3.15	1.51	0.48	683	3.05	1.46	0.48	718
26	18	2.94	2.59	0.88	552	2.81	2.48	0.88	580	2.70	2.38	0.88	607	2.60	2.29	0.88	635
26	20	3.06	2.33	0.76	580	2.94	2.23	0.76	614	2.85	2.17	0.76	628	2.75	2.09	0.76	656
26	22	3.19	2.04	0.64	600	3.08	1.97	0.64	638	3.00	1.92	0.64	656	2.88	1.84	0.64	683
26	24	3.35	1.74	0.52	628	3.23	1.68	0.52	662	3.15	1.64	0.52	683	3.05	1.59	0.52	718
26	26	3.45	1.38	0.40	662	3.35	1.34	0.40	697	3.30	1.32	0.40	718	3.20	1.28	0.40	738
27	18	2.94	2.70	0.92	552	2.81	2.59	0.92	580	2.70	2.48	0.92	607	2.60	2.39	0.92	635
27	20	3.06	2.45	0.80	580	2.94	2.35	0.80	614	2.85	2.28	0.80	628	2.75	2.20	0.80	656
27	22	3.19	2.17	0.68	600	3.08	2.09	0.68	638	3.00	2.04	0.68	656	2.88	1.96	0.68	683
27	24	3.35	1.88	0.56	628	3.23	1.81	0.56	662	3.15	1.76	0.56	683	3.05	1.71	0.56	718
27	26	3.45	1.52	0.44	662	3.35	1.47	0.44	697	3.30	1.45	0.44	718	3.20	1.41	0.44	738
28	18	2.94	2.82	0.96	552	2.81	2.70	0.96	580	2.70	2.59	0.96	607	2.60	2.50	0.96	635
28	20	3.06	2.57	0.84	580	2.94	2.47	0.84	614	2.85	2.39	0.84	628	2.75	2.31	0.84	656
28	22	3.19	2.30	0.72	600	3.08	2.21	0.72	638	3.00	2.16	0.72	656	2.88	2.07	0.72	683
28	24	3.35	2.01	0.60	628	3.23	1.94	0.60	662	3.15	1.89	0.60	683	3.05	1.83	0.60	718
28	26	3.45	1.66	0.48	662	3.35	1.61	0.48	697	3.30	1.58	0.48	718	3.20	1.54	0.48	738
29	18	2.94	2.94	1.00	552	2.81	2.81	1.00	580	2.70	2.70	1.00	607	2.60	2.60	1.00	635
29	20	3.06	2.70	0.88	580	2.94	2.59	0.88	614	2.85	2.51	0.88	628	2.75	2.42	0.88	656
29	22	3.19	2.42	0.76	600	3.08	2.34	0.76	638	3.00	2.28	0.76	656	2.88	2.19	0.76	683
29	24	3.35	2.14	0.64	628	3.23	2.06	0.64	662	3.15	2.02	0.64	683	3.05	1.95	0.64	718
29	26	3.45	1.79	0.52	662	3.35	1.74	0.52	697	3.30	1.72	0.52	718	3.20	1.66	0.52	738
30	18	2.94	2.94	1.00	552	2.81	2.81	1.00	580	2.70	2.70	1.00	607	2.60	2.60	1.00	635
30	20	3.06	2.82	0.92	580	2.94	2.70	0.92	614	2.85	2.62	0.92	628	2.75	2.53	0.92	656
30	22	3.19	2.55	0.80	600	3.08	2.46	0.80	638	3.00	2.40	0.80	656	2.88	2.30	0.80	683
30	24	3.35	2.28	0.68	628	3.23	2.19	0.68	662	3.15	2.14	0.68	683	3.05	2.07	0.68	718
30	26	3.45	1.93	0.56	662	3.35	1.88	0.56	697	3.30	1.85	0.56	718	3.20	1.79	0.56	738
31	18	2.94	2.94	1.00	552	2.81	2.81	1.00	580	2.70	2.70	1.00	607	2.60	2.60	1.00	635
31	20	3.06	2.94	0.96	580	2.94	2.82	0.96	614	2.85	2.74	0.96	628	2.75	2.64	0.96	656
31	22	3.19	2.68	0.84	600	3.08	2.58	0.84	638	3.00	2.52	0.84	656	2.88	2.42	0.84	683
31	24	3.35	2.41	0.72	628	3.23	2.32	0.72	662	3.15	2.27	0.72	683	3.05	2.20	0.72	718
31	26	3.45	2.07	0.60	662	3.35	2.01	0.60	697	3.30	1.98	0.60	718	3.20	1.92	0.60	738
32	18	2.94	2.94	1.00	552	2.81	2.81	1.00	580	2.70	2.70	1.00	607	2.60	2.60	1.00	635
32	20	3.06	3.06	1.00	580	2.94	2.94	1.00	614	2.85	2.85	1.00	628	2.75	2.75	1.00	656
32	22	3.19	2.81	0.88	600	3.08	2.71	0.88	638	3.00	2.64	0.88	656	2.88	2.53	0.88	683
32	24	3.35	2.55	0.76	628	3.23	2.45	0.76	662	3.15	2.39	0.76	683	3.05	2.32	0.76	718
32	26	3.45	2.21	0.64	662	3.35	2.14	0.64	697	3.30	2.11	0.64	718	3.20	2.05	0.64	738

**NOTE** Q : Total capacity (kW) SHF : Sensible heat factor DB : Dry-bulb temperature  
 SHC : Sensible heat capacity (kW) INPUT : Total power input (W) WB : Wet-bulb temperature

**PERFORMANCE DATA**

**COOLING operation at Rated frequency**

**SLZ-KA25VA(L)/SUZ-KA25VA(H)**

CAPACITY : 2.5(kW) INPUT : 690(W) SHF : 0.86

		OUTDOOR D.B.(°C)											
INDOOR D.B.(°C)	INDOOR W.B.(°C)	35				40				46			
		Q	SHC	SHF	INPUT	Q	SHC	SHF	INPUT	Q	SHC	SHF	INPUT
21	18	2.45	1.67	0.68	676	2.25	1.53	0.68	718	2.08	1.41	0.68	745
21	20	2.58	1.44	0.56	704	2.40	1.34	0.56	738	2.23	1.25	0.56	780
22	18	2.45	1.76	0.72	676	2.25	1.62	0.72	718	2.08	1.49	0.72	745
22	20	2.58	1.55	0.60	704	2.40	1.44	0.60	738	2.23	1.34	0.60	780
22	22	2.73	1.31	0.48	731	2.55	1.22	0.48	773	2.38	1.14	0.48	800
23	18	2.45	1.86	0.76	676	2.25	1.71	0.76	718	2.08	1.58	0.76	745
23	20	2.58	1.65	0.64	704	2.40	1.54	0.64	738	2.23	1.42	0.64	780
23	22	2.73	1.42	0.52	731	2.55	1.33	0.52	773	2.38	1.24	0.52	800
24	18	2.45	1.96	0.80	676	2.25	1.80	0.80	718	2.08	1.66	0.80	745
24	20	2.58	1.75	0.68	704	2.40	1.63	0.68	738	2.23	1.51	0.68	780
24	22	2.73	1.53	0.56	731	2.55	1.43	0.56	773	2.38	1.33	0.56	800
24	24	2.88	1.27	0.44	759	2.70	1.19	0.44	794	2.55	1.12	0.44	828
25	20	2.58	1.85	0.72	704	2.40	1.73	0.72	738	2.23	1.60	0.72	780
25	22	2.73	1.64	0.60	731	2.55	1.53	0.60	773	2.38	1.43	0.60	800
25	24	2.88	1.38	0.48	759	2.70	1.30	0.48	794	2.55	1.22	0.48	828
26	18	2.45	2.16	0.88	676	2.25	1.98	0.88	718	2.08	1.83	0.88	745
26	20	2.58	1.96	0.76	704	2.40	1.82	0.76	738	2.23	1.69	0.76	780
26	22	2.73	1.74	0.64	731	2.55	1.63	0.64	773	2.38	1.52	0.64	800
26	24	2.88	1.50	0.52	759	2.70	1.40	0.52	794	2.55	1.33	0.52	828
26	26	3.03	1.21	0.40	787	2.85	1.14	0.40	821	2.68	1.07	0.40	856
27	18	2.45	2.25	0.92	676	2.25	2.07	0.92	718	2.08	1.91	0.92	745
27	20	2.58	2.06	0.80	704	2.40	1.92	0.80	738	2.23	1.78	0.80	780
27	22	2.73	1.85	0.68	731	2.55	1.73	0.68	773	2.38	1.62	0.68	800
27	24	2.88	1.61	0.56	759	2.70	1.51	0.56	794	2.55	1.43	0.56	828
27	26	3.03	1.33	0.44	787	2.85	1.25	0.44	821	2.68	1.18	0.44	856
28	18	2.45	2.35	0.96	676	2.25	2.16	0.96	718	2.08	1.99	0.96	745
28	20	2.58	2.16	0.84	704	2.40	2.02	0.84	738	2.23	1.87	0.84	780
28	22	2.73	1.96	0.72	731	2.55	1.84	0.72	773	2.38	1.71	0.72	800
28	24	2.88	1.73	0.60	759	2.70	1.62	0.60	794	2.55	1.53	0.60	828
28	26	3.03	1.45	0.48	787	2.85	1.37	0.48	821	2.68	1.28	0.48	856
29	18	2.45	2.45	1.00	676	2.25	2.25	1.00	718	2.08	2.08	1.00	745
29	20	2.58	2.27	0.88	704	2.40	2.11	0.88	738	2.23	1.96	0.88	780
29	22	2.73	2.07	0.76	731	2.55	1.94	0.76	773	2.38	1.81	0.76	800
29	24	2.88	1.84	0.64	759	2.70	1.73	0.64	794	2.55	1.63	0.64	828
29	26	3.03	1.57	0.52	787	2.85	1.48	0.52	821	2.68	1.39	0.52	856
30	18	2.45	2.45	1.00	676	2.25	2.25	1.00	718	2.08	2.08	1.00	745
30	20	2.58	2.37	0.92	704	2.40	2.21	0.92	738	2.23	2.05	0.92	780
30	22	2.73	2.18	0.80	731	2.55	2.04	0.80	773	2.38	1.90	0.80	800
30	24	2.88	1.96	0.68	759	2.70	1.84	0.68	794	2.55	1.73	0.68	828
30	26	3.03	1.69	0.56	787	2.85	1.60	0.56	821	2.68	1.50	0.56	856
31	18	2.45	2.45	1.00	676	2.25	2.25	1.00	718	2.08	2.08	1.00	745
31	20	2.58	2.47	0.96	704	2.40	2.30	0.96	738	2.23	2.14	0.96	780
31	22	2.73	2.29	0.84	731	2.55	2.14	0.84	773	2.38	2.00	0.84	800
31	24	2.88	2.07	0.72	759	2.70	1.94	0.72	794	2.55	1.84	0.72	828
31	26	3.03	1.82	0.60	787	2.85	1.71	0.60	821	2.68	1.61	0.60	856
32	18	2.45	2.45	1.00	676	2.25	2.25	1.00	718	2.08	2.08	1.00	745
32	20	2.58	2.58	1.00	704	2.40	2.40	1.00	738	2.23	2.23	1.00	780
32	22	2.73	2.40	0.88	731	2.55	2.24	0.88	773	2.38	2.09	0.88	800
32	24	2.88	2.19	0.76	759	2.70	2.05	0.76	794	2.55	1.94	0.76	828
32	26	3.03	1.94	0.64	787	2.85	1.82	0.64	821	2.68	1.71	0.64	856

**NOTE** Q : Total capacity (kW) SHF : Sensible heat factor DB : Dry-bulb temperature  
 SHC : Sensible heat capacity (kW) INPUT : Total power input (W) WB : Wet-bulb temperature



**PERFORMANCE DATA**

**COOLING operation at Rated frequency**

**SLZ-KA35VA(L)/SUZ-KA35VA(H)**

CAPACITY : 3.5(kW) INPUT : 1060(W) SHF : 0.77

		OUTDOOR D.B.(°C)															
INDOOR D.B.(°C)	INDOOR W.B.(°C)	21				25				27				30			
		Q	SHC	SHF	INPUT	Q	SHC	SHF	INPUT	Q	SHC	SHF	INPUT	Q	SHC	SHF	INPUT
21	18	4.11	2.43	0.59	848	3.94	2.32	0.59	890	3.78	2.23	0.59	933	3.64	2.15	0.59	975
21	20	4.29	2.02	0.47	890	4.11	1.93	0.47	943	3.99	1.88	0.47	965	3.85	1.81	0.47	1007
22	18	4.11	2.59	0.63	848	3.94	2.48	0.63	890	3.78	2.38	0.63	933	3.64	2.29	0.63	975
22	20	4.29	2.19	0.51	890	4.11	2.10	0.51	943	3.99	2.03	0.51	965	3.85	1.96	0.51	1007
22	22	4.46	1.74	0.39	922	4.31	1.68	0.39	981	4.20	1.64	0.39	1007	4.03	1.57	0.39	1049
23	18	4.11	2.76	0.67	848	3.94	2.64	0.67	890	3.78	2.53	0.67	933	3.64	2.44	0.67	975
23	20	4.29	2.36	0.55	890	4.11	2.26	0.55	943	3.99	2.19	0.55	965	3.85	2.12	0.55	1007
23	22	4.46	1.92	0.43	922	4.31	1.85	0.43	981	4.20	1.81	0.43	1007	4.03	1.73	0.43	1049
24	18	4.11	2.92	0.71	848	3.94	2.80	0.71	890	3.78	2.68	0.71	933	3.64	2.58	0.71	975
24	20	4.29	2.53	0.59	890	4.11	2.43	0.59	943	3.99	2.35	0.59	965	3.85	2.27	0.59	1007
24	22	4.46	2.10	0.47	922	4.31	2.02	0.47	981	4.20	1.97	0.47	1007	4.03	1.89	0.47	1049
24	24	4.69	1.64	0.35	965	4.52	1.58	0.35	1018	4.41	1.54	0.35	1049	4.27	1.49	0.35	1102
25	20	4.29	2.70	0.63	890	4.11	2.59	0.63	943	3.99	2.51	0.63	965	3.85	2.43	0.63	1007
25	22	4.46	2.28	0.51	922	4.31	2.20	0.51	981	4.20	2.14	0.51	1007	4.03	2.05	0.51	1049
25	24	4.69	1.83	0.39	965	4.52	1.76	0.39	1018	4.41	1.72	0.39	1049	4.27	1.67	0.39	1102
26	18	4.11	3.25	0.79	848	3.94	3.11	0.79	890	3.78	2.99	0.79	933	3.64	2.88	0.79	975
26	20	4.29	2.87	0.67	890	4.11	2.76	0.67	943	3.99	2.67	0.67	965	3.85	2.58	0.67	1007
26	22	4.46	2.45	0.55	922	4.31	2.37	0.55	981	4.20	2.31	0.55	1007	4.03	2.21	0.55	1049
26	24	4.69	2.02	0.43	965	4.52	1.94	0.43	1018	4.41	1.90	0.43	1049	4.27	1.84	0.43	1102
26	26	4.83	1.50	0.31	1018	4.69	1.45	0.31	1071	4.62	1.43	0.31	1102	4.48	1.39	0.31	1134
27	18	4.11	3.41	0.83	848	3.94	3.27	0.83	890	3.78	3.14	0.83	933	3.64	3.02	0.83	975
27	20	4.29	3.04	0.71	890	4.11	2.92	0.71	943	3.99	2.83	0.71	965	3.85	2.73	0.71	1007
27	22	4.46	2.63	0.59	922	4.31	2.54	0.59	981	4.20	2.48	0.59	1007	4.03	2.37	0.59	1049
27	24	4.69	2.20	0.47	965	4.52	2.12	0.47	1018	4.41	2.07	0.47	1049	4.27	2.01	0.47	1102
27	26	4.83	1.69	0.35	1018	4.69	1.64	0.35	1071	4.62	1.62	0.35	1102	4.48	1.57	0.35	1134
28	18	4.11	3.58	0.87	848	3.94	3.43	0.87	890	3.78	3.29	0.87	933	3.64	3.17	0.87	975
28	20	4.29	3.22	0.75	890	4.11	3.08	0.75	943	3.99	2.99	0.75	965	3.85	2.89	0.75	1007
28	22	4.46	2.81	0.63	922	4.31	2.71	0.63	981	4.20	2.65	0.63	1007	4.03	2.54	0.63	1049
28	24	4.69	2.39	0.51	965	4.52	2.30	0.51	1018	4.41	2.25	0.51	1049	4.27	2.18	0.51	1102
28	26	4.83	1.88	0.39	1018	4.69	1.83	0.39	1071	4.62	1.80	0.39	1102	4.48	1.75	0.39	1134
29	18	4.11	3.74	0.91	848	3.94	3.58	0.91	890	3.78	3.44	0.91	933	3.64	3.31	0.91	975
29	20	4.29	3.39	0.79	890	4.11	3.25	0.79	943	3.99	3.15	0.79	965	3.85	3.04	0.79	1007
29	22	4.46	2.99	0.67	922	4.31	2.88	0.67	981	4.20	2.81	0.67	1007	4.03	2.70	0.67	1049
29	24	4.69	2.58	0.55	965	4.52	2.48	0.55	1018	4.41	2.43	0.55	1049	4.27	2.35	0.55	1102
29	26	4.83	2.08	0.43	1018	4.69	2.02	0.43	1071	4.62	1.99	0.43	1102	4.48	1.93	0.43	1134
30	18	4.11	3.91	0.95	848	3.94	3.74	0.95	890	3.78	3.59	0.95	933	3.64	3.46	0.95	975
30	20	4.29	3.56	0.83	890	4.11	3.41	0.83	943	3.99	3.31	0.83	965	3.85	3.20	0.83	1007
30	22	4.46	3.17	0.71	922	4.31	3.06	0.71	981	4.20	2.98	0.71	1007	4.03	2.86	0.71	1049
30	24	4.69	2.77	0.59	965	4.52	2.66	0.59	1018	4.41	2.60	0.59	1049	4.27	2.52	0.59	1102
30	26	4.83	2.27	0.47	1018	4.69	2.20	0.47	1071	4.62	2.17	0.47	1102	4.48	2.11	0.47	1134
31	18	4.11	4.07	0.99	848	3.94	3.90	0.99	890	3.78	3.74	0.99	933	3.64	3.60	0.99	975
31	20	4.29	3.73	0.87	890	4.11	3.58	0.87	943	3.99	3.47	0.87	965	3.85	3.35	0.87	1007
31	22	4.46	3.35	0.75	922	4.31	3.23	0.75	981	4.20	3.15	0.75	1007	4.03	3.02	0.75	1049
31	24	4.69	2.95	0.63	965	4.52	2.84	0.63	1018	4.41	2.78	0.63	1049	4.27	2.69	0.63	1102
31	26	4.83	2.46	0.51	1018	4.69	2.39	0.51	1071	4.62	2.36	0.51	1102	4.48	2.28	0.51	1134
32	18	4.11	4.11	1.00	848	3.94	3.94	1.00	890	3.78	3.78	1.00	933	3.64	3.64	1.00	975
32	20	4.29	3.90	0.91	890	4.11	3.74	0.91	943	3.99	3.63	0.91	965	3.85	3.50	0.91	1007
32	22	4.46	3.53	0.79	922	4.31	3.40	0.79	981	4.20	3.32	0.79	1007	4.03	3.18	0.79	1049
32	24	4.69	3.14	0.67	965	4.52	3.03	0.67	1018	4.41	2.95	0.67	1049	4.27	2.86	0.67	1102
32	26	4.83	2.66	0.55	1018	4.69	2.58	0.55	1071	4.62	2.54	0.55	1102	4.48	2.46	0.55	1134

**NOTE** Q : Total capacity (kW) SHF : Sensible heat factor DB : Dry-bulb temperature  
 SHC : Sensible heat capacity (kW) INPUT : Total power input (W) WB : Wet-bulb temperature

**PERFORMANCE DATA**

**COOLING operation at Rated frequency**

**SLZ-KA35VA(L)/SUZ-KA35VA(H)**

CAPACITY : 3.5(kW) INPUT : 1060(W) SHF : 0.77

		OUTDOOR D.B.(°C)											
INDOOR D.B.(°C)	INDOOR W.B.(°C)	35				40				46			
		Q	SHC	SHF	INPUT	Q	SHC	SHF	INPUT	Q	SHC	SHF	INPUT
21	18	3.43	2.02	0.59	1039	3.15	1.86	0.59	1102	2.91	1.71	0.59	1145
21	20	3.61	1.69	0.47	1081	3.36	1.58	0.47	1134	3.12	1.46	0.47	1198
22	18	3.43	2.16	0.63	1039	3.15	1.98	0.63	1102	2.91	1.83	0.63	1145
22	20	3.61	1.84	0.51	1081	3.36	1.71	0.51	1134	3.12	1.59	0.51	1198
22	22	3.82	1.49	0.39	1124	3.57	1.39	0.39	1187	3.33	1.30	0.39	1230
23	18	3.43	2.30	0.67	1039	3.15	2.11	0.67	1102	2.91	1.95	0.67	1145
23	20	3.61	1.98	0.55	1081	3.36	1.85	0.55	1134	3.12	1.71	0.55	1198
23	22	3.82	1.64	0.43	1124	3.57	1.54	0.43	1187	3.33	1.43	0.43	1230
24	18	3.43	2.44	0.71	1039	3.15	2.24	0.71	1102	2.91	2.06	0.71	1145
24	20	3.61	2.13	0.59	1081	3.36	1.98	0.59	1134	3.12	1.84	0.59	1198
24	22	3.82	1.79	0.47	1124	3.57	1.68	0.47	1187	3.33	1.56	0.47	1230
24	24	4.03	1.41	0.35	1166	3.78	1.32	0.35	1219	3.57	1.25	0.35	1272
25	20	3.61	2.27	0.63	1081	3.36	2.12	0.63	1134	3.12	1.96	0.63	1198
25	22	3.82	1.95	0.51	1124	3.57	1.82	0.51	1187	3.33	1.70	0.51	1230
25	24	4.03	1.57	0.39	1166	3.78	1.47	0.39	1219	3.57	1.39	0.39	1272
26	18	3.43	2.71	0.79	1039	3.15	2.49	0.79	1102	2.91	2.29	0.79	1145
26	20	3.61	2.42	0.67	1081	3.36	2.25	0.67	1134	3.12	2.09	0.67	1198
26	22	3.82	2.10	0.55	1124	3.57	1.96	0.55	1187	3.33	1.83	0.55	1230
26	24	4.03	1.73	0.43	1166	3.78	1.63	0.43	1219	3.57	1.54	0.43	1272
26	26	4.24	1.31	0.31	1208	3.99	1.24	0.31	1261	3.75	1.16	0.31	1314
27	18	3.43	2.85	0.83	1039	3.15	2.61	0.83	1102	2.91	2.41	0.83	1145
27	20	3.61	2.56	0.71	1081	3.36	2.39	0.71	1134	3.12	2.21	0.71	1198
27	22	3.82	2.25	0.59	1124	3.57	2.11	0.59	1187	3.33	1.96	0.59	1230
27	24	4.03	1.89	0.47	1166	3.78	1.78	0.47	1219	3.57	1.68	0.47	1272
27	26	4.24	1.48	0.35	1208	3.99	1.40	0.35	1261	3.75	1.31	0.35	1314
28	18	3.43	2.98	0.87	1039	3.15	2.74	0.87	1102	2.91	2.53	0.87	1145
28	20	3.61	2.70	0.75	1081	3.36	2.52	0.75	1134	3.12	2.34	0.75	1198
28	22	3.82	2.40	0.63	1124	3.57	2.25	0.63	1187	3.33	2.09	0.63	1230
28	24	4.03	2.05	0.51	1166	3.78	1.93	0.51	1219	3.57	1.82	0.51	1272
28	26	4.24	1.65	0.39	1208	3.99	1.56	0.39	1261	3.75	1.46	0.39	1314
29	18	3.43	3.12	0.91	1039	3.15	2.87	0.91	1102	2.91	2.64	0.91	1145
29	20	3.61	2.85	0.79	1081	3.36	2.65	0.79	1134	3.12	2.46	0.79	1198
29	22	3.82	2.56	0.67	1124	3.57	2.39	0.67	1187	3.33	2.23	0.67	1230
29	24	4.03	2.21	0.55	1166	3.78	2.08	0.55	1219	3.57	1.96	0.55	1272
29	26	4.24	1.82	0.43	1208	3.99	1.72	0.43	1261	3.75	1.61	0.43	1314
30	18	3.43	3.26	0.95	1039	3.15	2.99	0.95	1102	2.91	2.76	0.95	1145
30	20	3.61	2.99	0.83	1081	3.36	2.79	0.83	1134	3.12	2.59	0.83	1198
30	22	3.82	2.71	0.71	1124	3.57	2.53	0.71	1187	3.33	2.36	0.71	1230
30	24	4.03	2.37	0.59	1166	3.78	2.23	0.59	1219	3.57	2.11	0.59	1272
30	26	4.24	1.99	0.47	1208	3.99	1.88	0.47	1261	3.75	1.76	0.47	1314
31	18	3.43	3.40	0.99	1039	3.15	3.12	0.99	1102	2.91	2.88	0.99	1145
31	20	3.61	3.14	0.87	1081	3.36	2.92	0.87	1134	3.12	2.71	0.87	1198
31	22	3.82	2.86	0.75	1124	3.57	2.68	0.75	1187	3.33	2.49	0.75	1230
31	24	4.03	2.54	0.63	1166	3.78	2.38	0.63	1219	3.57	2.25	0.63	1272
31	26	4.24	2.16	0.51	1208	3.99	2.03	0.51	1261	3.75	1.91	0.51	1314
32	18	3.43	3.43	1.00	1039	3.15	3.15	1.00	1102	2.91	2.91	1.00	1145
32	20	3.61	3.28	0.91	1081	3.36	3.06	0.91	1134	3.12	2.83	0.91	1198
32	22	3.82	3.01	0.79	1124	3.57	2.82	0.79	1187	3.33	2.63	0.79	1230
32	24	4.03	2.70	0.67	1166	3.78	2.53	0.67	1219	3.57	2.39	0.67	1272
32	26	4.24	2.33	0.55	1208	3.99	2.19	0.55	1261	3.75	2.06	0.55	1314

**NOTE** Q : Total capacity (kW) SHF : Sensible heat factor DB : Dry-bulb temperature  
 SHC : Sensible heat capacity (kW) INPUT : Total power input (W) WB : Wet-bulb temperature

**PERFORMANCE DATA**

**COOLING operation at Rated frequency**

**SLZ-KA50VA(L)/SUZ-KA50VA**

CAPACITY : 4.6(kW) INPUT : 1630(W) SHF : 0.68

		OUTDOOR D.B.(°C)															
INDOOR D.B.(°C)	INDOOR W.B.(°C)	21				25				27				30			
		Q	SHC	SHF	INPUT	Q	SHC	SHF	INPUT	Q	SHC	SHF	INPUT	Q	SHC	SHF	INPUT
21	18	5.41	2.70	0.50	1304	5.18	2.59	0.50	1369	4.97	2.48	0.50	1434	4.78	2.39	0.50	1500
21	20	5.64	2.14	0.38	1369	5.41	2.05	0.38	1451	5.24	1.99	0.38	1483	5.06	1.92	0.38	1549
22	18	5.41	2.92	0.54	1304	5.18	2.79	0.54	1369	4.97	2.68	0.54	1434	4.78	2.58	0.54	1500
22	20	5.64	2.37	0.42	1369	5.41	2.27	0.42	1451	5.24	2.20	0.42	1483	5.06	2.13	0.42	1549
22	22	5.87	1.76	0.30	1418	5.66	1.70	0.30	1508	5.52	1.66	0.30	1549	5.29	1.59	0.30	1614
23	18	5.41	3.13	0.58	1304	5.18	3.00	0.58	1369	4.97	2.88	0.58	1434	4.78	2.77	0.58	1500
23	20	5.64	2.59	0.46	1369	5.41	2.49	0.46	1451	5.24	2.41	0.46	1483	5.06	2.33	0.46	1549
23	22	5.87	1.99	0.34	1418	5.66	1.92	0.34	1508	5.52	1.88	0.34	1549	5.29	1.80	0.34	1614
24	18	5.41	3.35	0.62	1304	5.18	3.21	0.62	1369	4.97	3.08	0.62	1434	4.78	2.97	0.62	1500
24	20	5.64	2.82	0.50	1369	5.41	2.70	0.50	1451	5.24	2.62	0.50	1483	5.06	2.53	0.50	1549
24	22	5.87	2.23	0.38	1418	5.66	2.15	0.38	1508	5.52	2.10	0.38	1549	5.29	2.01	0.38	1614
24	24	6.16	1.60	0.26	1483	5.93	1.54	0.26	1565	5.80	1.51	0.26	1614	5.61	1.46	0.26	1695
25	20	5.64	3.04	0.54	1369	5.41	2.92	0.54	1451	5.24	2.83	0.54	1483	5.06	2.73	0.54	1549
25	22	5.87	2.46	0.42	1418	5.66	2.38	0.42	1508	5.52	2.32	0.42	1549	5.29	2.22	0.42	1614
25	24	6.16	1.85	0.30	1483	5.93	1.78	0.30	1565	5.80	1.74	0.30	1614	5.61	1.68	0.30	1695
26	18	5.41	3.78	0.70	1304	5.18	3.62	0.70	1369	4.97	3.48	0.70	1434	4.78	3.35	0.70	1500
26	20	5.64	3.27	0.58	1369	5.41	3.13	0.58	1451	5.24	3.04	0.58	1483	5.06	2.93	0.58	1549
26	22	5.87	2.70	0.46	1418	5.66	2.60	0.46	1508	5.52	2.54	0.46	1549	5.29	2.43	0.46	1614
26	24	6.16	2.10	0.34	1483	5.93	2.02	0.34	1565	5.80	1.97	0.34	1614	5.61	1.91	0.34	1695
26	26	6.35	1.40	0.22	1565	6.16	1.36	0.22	1646	6.07	1.34	0.22	1695	5.89	1.30	0.22	1744
27	18	5.41	4.00	0.74	1304	5.18	3.83	0.74	1369	4.97	3.68	0.74	1434	4.78	3.54	0.74	1500
27	20	5.64	3.49	0.62	1369	5.41	3.35	0.62	1451	5.24	3.25	0.62	1483	5.06	3.14	0.62	1549
27	22	5.87	2.93	0.50	1418	5.66	2.83	0.50	1508	5.52	2.76	0.50	1549	5.29	2.65	0.50	1614
27	24	6.16	2.34	0.38	1483	5.93	2.25	0.38	1565	5.80	2.20	0.38	1614	5.61	2.13	0.38	1695
27	26	6.35	1.65	0.26	1565	6.16	1.60	0.26	1646	6.07	1.58	0.26	1695	5.89	1.53	0.26	1744
28	18	5.41	4.22	0.78	1304	5.18	4.04	0.78	1369	4.97	3.88	0.78	1434	4.78	3.73	0.78	1500
28	20	5.64	3.72	0.66	1369	5.41	3.57	0.66	1451	5.24	3.46	0.66	1483	5.06	3.34	0.66	1549
28	22	5.87	3.17	0.54	1418	5.66	3.06	0.54	1508	5.52	2.98	0.54	1549	5.29	2.86	0.54	1614
28	24	6.16	2.59	0.42	1483	5.93	2.49	0.42	1565	5.80	2.43	0.42	1614	5.61	2.36	0.42	1695
28	26	6.35	1.90	0.30	1565	6.16	1.85	0.30	1646	6.07	1.82	0.30	1695	5.89	1.77	0.30	1744
29	18	5.41	4.43	0.82	1304	5.18	4.24	0.82	1369	4.97	4.07	0.82	1434	4.78	3.92	0.82	1500
29	20	5.64	3.94	0.70	1369	5.41	3.78	0.70	1451	5.24	3.67	0.70	1483	5.06	3.54	0.70	1549
29	22	5.87	3.40	0.58	1418	5.66	3.28	0.58	1508	5.52	3.20	0.58	1549	5.29	3.07	0.58	1614
29	24	6.16	2.84	0.46	1483	5.93	2.73	0.46	1565	5.80	2.67	0.46	1614	5.61	2.58	0.46	1695
29	26	6.35	2.16	0.34	1565	6.16	2.10	0.34	1646	6.07	2.06	0.34	1695	5.89	2.00	0.34	1744
30	18	5.41	4.65	0.86	1304	5.18	4.45	0.86	1369	4.97	4.27	0.86	1434	4.78	4.11	0.86	1500
30	20	5.64	4.17	0.74	1369	5.41	4.00	0.74	1451	5.24	3.88	0.74	1483	5.06	3.74	0.74	1549
30	22	5.87	3.64	0.62	1418	5.66	3.51	0.62	1508	5.52	3.42	0.62	1549	5.29	3.28	0.62	1614
30	24	6.16	3.08	0.50	1483	5.93	2.97	0.50	1565	5.80	2.90	0.50	1614	5.61	2.81	0.50	1695
30	26	6.35	2.41	0.38	1565	6.16	2.34	0.38	1646	6.07	2.31	0.38	1695	5.89	2.24	0.38	1744
31	18	5.41	4.86	0.90	1304	5.18	4.66	0.90	1369	4.97	4.47	0.90	1434	4.78	4.31	0.90	1500
31	20	5.64	4.40	0.78	1369	5.41	4.22	0.78	1451	5.24	4.09	0.78	1483	5.06	3.95	0.78	1549
31	22	5.87	3.87	0.66	1418	5.66	3.73	0.66	1508	5.52	3.64	0.66	1549	5.29	3.49	0.66	1614
31	24	6.16	3.33	0.54	1483	5.93	3.20	0.54	1565	5.80	3.13	0.54	1614	5.61	3.03	0.54	1695
31	26	6.35	2.67	0.42	1565	6.16	2.59	0.42	1646	6.07	2.55	0.42	1695	5.89	2.47	0.42	1744
32	18	5.41	5.08	0.94	1304	5.18	4.86	0.94	1369	4.97	4.67	0.94	1434	4.78	4.50	0.94	1500
32	20	5.64	4.62	0.82	1369	5.41	4.43	0.82	1451	5.24	4.30	0.82	1483	5.06	4.15	0.82	1549
32	22	5.87	4.11	0.70	1418	5.66	3.96	0.70	1508	5.52	3.86	0.70	1549	5.29	3.70	0.70	1614
32	24	6.16	3.58	0.58	1483	5.93	3.44	0.58	1565	5.80	3.36	0.58	1614	5.61	3.25	0.58	1695
32	26	6.35	2.92	0.46	1565	6.16	2.84	0.46	1646	6.07	2.79	0.46	1695	5.89	2.71	0.46	1744

**NOTE** Q : Total capacity (kW) SHF : Sensible heat factor DB : Dry-bulb temperature  
 SHC : Sensible heat capacity (kW) INPUT : Total power input (W) WB : Wet-bulb temperature

**PERFORMANCE DATA**

**COOLING operation at Rated frequency**

**SLZ-KA50VA(L)/SUZ-KA50VA**

CAPACITY : 4.6(kW) INPUT : 1630(W) SHF : 0.68

		OUTDOOR D.B.(°C)											
INDOOR D.B.(°C)	INDOOR W.B.(°C)	35				40				46			
		Q	SHC	SHF	INPUT	Q	SHC	SHF	INPUT	Q	SHC	SHF	INPUT
21	18	4.51	2.25	0.50	1597	4.14	2.07	0.50	1695	3.82	1.91	0.50	1760
21	20	4.74	1.80	0.38	1663	4.42	1.68	0.38	1744	4.09	1.56	0.38	1842
22	18	4.51	2.43	0.54	1597	4.14	2.24	0.54	1695	3.82	2.06	0.54	1760
22	20	4.74	1.99	0.42	1663	4.42	1.85	0.42	1744	4.09	1.72	0.42	1842
22	22	5.01	1.50	0.30	1728	4.69	1.41	0.30	1826	4.37	1.31	0.30	1891
23	18	4.51	2.61	0.58	1597	4.14	2.40	0.58	1695	3.82	2.21	0.58	1760
23	20	4.74	2.18	0.46	1663	4.42	2.03	0.46	1744	4.09	1.88	0.46	1842
23	22	5.01	1.70	0.34	1728	4.69	1.60	0.34	1826	4.37	1.49	0.34	1891
24	18	4.51	2.79	0.62	1597	4.14	2.57	0.62	1695	3.82	2.37	0.62	1760
24	20	4.74	2.37	0.50	1663	4.42	2.21	0.50	1744	4.09	2.05	0.50	1842
24	22	5.01	1.91	0.38	1728	4.69	1.78	0.38	1826	4.37	1.66	0.38	1891
24	24	5.29	1.38	0.26	1793	4.97	1.29	0.26	1875	4.69	1.22	0.26	1956
25	20	4.74	2.56	0.54	1663	4.42	2.38	0.54	1744	4.09	2.21	0.54	1842
25	22	5.01	2.11	0.42	1728	4.69	1.97	0.42	1826	4.37	1.84	0.42	1891
25	24	5.29	1.59	0.30	1793	4.97	1.49	0.30	1875	4.69	1.41	0.30	1956
26	18	4.51	3.16	0.70	1597	4.14	2.90	0.70	1695	3.82	2.67	0.70	1760
26	20	4.74	2.75	0.58	1663	4.42	2.56	0.58	1744	4.09	2.37	0.58	1842
26	22	5.01	2.31	0.46	1728	4.69	2.16	0.46	1826	4.37	2.01	0.46	1891
26	24	5.29	1.80	0.34	1793	4.97	1.69	0.34	1875	4.69	1.60	0.34	1956
26	26	5.57	1.22	0.22	1858	5.24	1.15	0.22	1940	4.92	1.08	0.22	2021
27	18	4.51	3.34	0.74	1597	4.14	3.06	0.74	1695	3.82	2.83	0.74	1760
27	20	4.74	2.94	0.62	1663	4.42	2.74	0.62	1744	4.09	2.54	0.62	1842
27	22	5.01	2.51	0.50	1728	4.69	2.35	0.50	1826	4.37	2.19	0.50	1891
27	24	5.29	2.01	0.38	1793	4.97	1.89	0.38	1875	4.69	1.78	0.38	1956
27	26	5.57	1.45	0.26	1858	5.24	1.36	0.26	1940	4.92	1.28	0.26	2021
28	18	4.51	3.52	0.78	1597	4.14	3.23	0.78	1695	3.82	2.98	0.78	1760
28	20	4.74	3.13	0.66	1663	4.42	2.91	0.66	1744	4.09	2.70	0.66	1842
28	22	5.01	2.71	0.54	1728	4.69	2.53	0.54	1826	4.37	2.36	0.54	1891
28	24	5.29	2.22	0.42	1793	4.97	2.09	0.42	1875	4.69	1.97	0.42	1956
28	26	5.57	1.67	0.30	1858	5.24	1.57	0.30	1940	4.92	1.48	0.30	2021
29	18	4.51	3.70	0.82	1597	4.14	3.39	0.82	1695	3.82	3.13	0.82	1760
29	20	4.74	3.32	0.70	1663	4.42	3.09	0.70	1744	4.09	2.87	0.70	1842
29	22	5.01	2.91	0.58	1728	4.69	2.72	0.58	1826	4.37	2.53	0.58	1891
29	24	5.29	2.43	0.46	1793	4.97	2.29	0.46	1875	4.69	2.16	0.46	1956
29	26	5.57	1.89	0.34	1858	5.24	1.78	0.34	1940	4.92	1.67	0.34	2021
30	18	4.51	3.88	0.86	1597	4.14	3.56	0.86	1695	3.82	3.28	0.86	1760
30	20	4.74	3.51	0.74	1663	4.42	3.27	0.74	1744	4.09	3.03	0.74	1842
30	22	5.01	3.11	0.62	1728	4.69	2.91	0.62	1826	4.37	2.71	0.62	1891
30	24	5.29	2.65	0.50	1793	4.97	2.48	0.50	1875	4.69	2.35	0.50	1956
30	26	5.57	2.12	0.38	1858	5.24	1.99	0.38	1940	4.92	1.87	0.38	2021
31	18	4.51	4.06	0.90	1597	4.14	3.73	0.90	1695	3.82	3.44	0.90	1760
31	20	4.74	3.70	0.78	1663	4.42	3.44	0.78	1744	4.09	3.19	0.78	1842
31	22	5.01	3.31	0.66	1728	4.69	3.10	0.66	1826	4.37	2.88	0.66	1891
31	24	5.29	2.86	0.54	1793	4.97	2.68	0.54	1875	4.69	2.53	0.54	1956
31	26	5.57	2.34	0.42	1858	5.24	2.20	0.42	1940	4.92	2.07	0.42	2021
32	18	4.51	4.24	0.94	1597	4.14	3.89	0.94	1695	3.82	3.59	0.94	1760
32	20	4.74	3.89	0.82	1663	4.42	3.62	0.82	1744	4.09	3.36	0.82	1842
32	22	5.01	3.51	0.70	1728	4.69	3.28	0.70	1826	4.37	3.06	0.70	1891
32	24	5.29	3.07	0.58	1793	4.97	2.88	0.58	1875	4.69	2.72	0.58	1956
32	26	5.57	2.56	0.46	1858	5.24	2.41	0.46	1940	4.92	2.26	0.46	2021

**NOTE** Q : Total capacity (kW) SHF : Sensible heat factor DB : Dry-bulb temperature  
 SHC : Sensible heat capacity (kW) INPUT : Total power input (W) WB : Wet-bulb temperature

**PERFORMANCE DATA**

**COOLING operation at Rated frequency**

**SEZ-KC25VA/SUZ-KA25VA(H)**

CAPACITY : 2.5(kW) INPUT : 730(W) SHF : 0.74

		OUTDOOR D.B.(°C)															
INDOOR D.B.(°C)	INDOOR W.B.(°C)	21				25				27				30			
		Q	SHC	SHF	INPUT	Q	SHC	SHF	INPUT	Q	SHC	SHF	INPUT	Q	SHC	SHF	INPUT
21	18	2.94	1.65	0.56	584	2.81	1.58	0.56	613	2.70	1.51	0.56	642	2.60	1.46	0.56	672
21	20	3.06	1.35	0.44	613	2.94	1.29	0.44	650	2.85	1.25	0.44	664	2.75	1.21	0.44	694
22	18	2.94	1.76	0.60	584	2.81	1.69	0.60	613	2.70	1.62	0.60	642	2.60	1.56	0.60	672
22	20	3.06	1.47	0.48	613	2.94	1.41	0.48	650	2.85	1.37	0.48	664	2.75	1.32	0.48	694
22	22	3.19	1.15	0.36	635	3.08	1.11	0.36	675	3.00	1.08	0.36	694	2.88	1.04	0.36	723
23	18	2.94	1.88	0.64	584	2.81	1.80	0.64	613	2.70	1.73	0.64	642	2.60	1.66	0.64	672
23	20	3.06	1.59	0.52	613	2.94	1.53	0.52	650	2.85	1.48	0.52	664	2.75	1.43	0.52	694
23	22	3.19	1.28	0.40	635	3.08	1.23	0.40	675	3.00	1.20	0.40	694	2.88	1.15	0.40	723
24	18	2.94	2.00	0.68	584	2.81	1.91	0.68	613	2.70	1.84	0.68	642	2.60	1.77	0.68	672
24	20	3.06	1.72	0.56	613	2.94	1.65	0.56	650	2.85	1.60	0.56	664	2.75	1.54	0.56	694
24	22	3.19	1.40	0.44	635	3.08	1.35	0.44	675	3.00	1.32	0.44	694	2.88	1.27	0.44	723
24	24	3.35	1.07	0.32	664	3.23	1.03	0.32	701	3.15	1.01	0.32	723	3.05	0.98	0.32	759
25	20	3.06	1.84	0.60	613	2.94	1.76	0.60	650	2.85	1.71	0.60	664	2.75	1.65	0.60	694
25	22	3.19	1.53	0.48	635	3.08	1.48	0.48	675	3.00	1.44	0.48	694	2.88	1.38	0.48	723
25	24	3.35	1.21	0.36	664	3.23	1.16	0.36	701	3.15	1.13	0.36	723	3.05	1.10	0.36	759
26	18	2.94	2.23	0.76	584	2.81	2.14	0.76	613	2.70	2.05	0.76	642	2.60	1.98	0.76	672
26	20	3.06	1.96	0.64	613	2.94	1.88	0.64	650	2.85	1.82	0.64	664	2.75	1.76	0.64	694
26	22	3.19	1.66	0.52	635	3.08	1.60	0.52	675	3.00	1.56	0.52	694	2.88	1.50	0.52	723
26	24	3.35	1.34	0.40	664	3.23	1.29	0.40	701	3.15	1.26	0.40	723	3.05	1.22	0.40	759
26	26	3.45	0.97	0.28	701	3.35	0.94	0.28	737	3.30	0.92	0.28	759	3.20	0.90	0.28	781
27	18	2.94	2.35	0.80	584	2.81	2.25	0.80	613	2.70	2.16	0.80	642	2.60	2.08	0.80	672
27	20	3.06	2.08	0.68	613	2.94	2.00	0.68	650	2.85	1.94	0.68	664	2.75	1.87	0.68	694
27	22	3.19	1.79	0.56	635	3.08	1.72	0.56	675	3.00	1.68	0.56	694	2.88	1.61	0.56	723
27	24	3.35	1.47	0.44	664	3.23	1.42	0.44	701	3.15	1.39	0.44	723	3.05	1.34	0.44	759
27	26	3.45	1.10	0.32	701	3.35	1.07	0.32	737	3.30	1.06	0.32	759	3.20	1.02	0.32	781
28	18	2.94	2.47	0.84	584	2.81	2.36	0.84	613	2.70	2.27	0.84	642	2.60	2.18	0.84	672
28	20	3.06	2.21	0.72	613	2.94	2.12	0.72	650	2.85	2.05	0.72	664	2.75	1.98	0.72	694
28	22	3.19	1.91	0.60	635	3.08	1.85	0.60	675	3.00	1.80	0.60	694	2.88	1.73	0.60	723
28	24	3.35	1.61	0.48	664	3.23	1.55	0.48	701	3.15	1.51	0.48	723	3.05	1.46	0.48	759
28	26	3.45	1.24	0.36	701	3.35	1.21	0.36	737	3.30	1.19	0.36	759	3.20	1.15	0.36	781
29	18	2.94	2.59	0.88	584	2.81	2.48	0.88	613	2.70	2.38	0.88	642	2.60	2.29	0.88	672
29	20	3.06	2.33	0.76	613	2.94	2.23	0.76	650	2.85	2.17	0.76	664	2.75	2.09	0.76	694
29	22	3.19	2.04	0.64	635	3.08	1.97	0.64	675	3.00	1.92	0.64	694	2.88	1.84	0.64	723
29	24	3.35	1.74	0.52	664	3.23	1.68	0.52	701	3.15	1.64	0.52	723	3.05	1.59	0.52	759
29	26	3.45	1.38	0.40	701	3.35	1.34	0.40	737	3.30	1.32	0.40	759	3.20	1.28	0.40	781
30	18	2.94	2.70	0.92	584	2.81	2.59	0.92	613	2.70	2.48	0.92	642	2.60	2.39	0.92	672
30	20	3.06	2.45	0.80	613	2.94	2.35	0.80	650	2.85	2.28	0.80	664	2.75	2.20	0.80	694
30	22	3.19	2.17	0.68	635	3.08	2.09	0.68	675	3.00	2.04	0.68	694	2.88	1.96	0.68	723
30	24	3.35	1.88	0.56	664	3.23	1.81	0.56	701	3.15	1.76	0.56	723	3.05	1.71	0.56	759
30	26	3.45	1.52	0.44	701	3.35	1.47	0.44	737	3.30	1.45	0.44	759	3.20	1.41	0.44	781
31	18	2.94	2.82	0.96	584	2.81	2.70	0.96	613	2.70	2.59	0.96	642	2.60	2.50	0.96	672
31	20	3.06	2.57	0.84	613	2.94	2.47	0.84	650	2.85	2.39	0.84	664	2.75	2.31	0.84	694
31	22	3.19	2.30	0.72	635	3.08	2.21	0.72	675	3.00	2.16	0.72	694	2.88	2.07	0.72	723
31	24	3.35	2.01	0.60	664	3.23	1.94	0.60	701	3.15	1.89	0.60	723	3.05	1.83	0.60	759
31	26	3.45	1.66	0.48	701	3.35	1.61	0.48	737	3.30	1.58	0.48	759	3.20	1.54	0.48	781
32	18	2.94	2.94	1.00	584	2.81	2.81	1.00	613	2.70	2.70	1.00	642	2.60	2.60	1.00	672
32	20	3.06	2.70	0.88	613	2.94	2.59	0.88	650	2.85	2.51	0.88	664	2.75	2.42	0.88	694
32	22	3.19	2.42	0.76	635	3.08	2.34	0.76	675	3.00	2.28	0.76	694	2.88	2.19	0.76	723
32	24	3.35	2.14	0.64	664	3.23	2.06	0.64	701	3.15	2.02	0.64	723	3.05	1.95	0.64	759
32	26	3.45	1.79	0.52	701	3.35	1.74	0.52	737	3.30	1.72	0.52	759	3.20	1.66	0.52	781

**NOTE** Q : Total capacity (kW) SHF : Sensible heat factor DB : Dry-bulb temperature  
 SHC : Sensible heat capacity (kW) INPUT : Total power input (W) WB : Wet-bulb temperature

**PERFORMANCE DATA**

**COOLING operation at Rated frequency**

**SEZ-KC25VA/SUZ-KA25VA(H)**

CAPACITY : 2.5(kW) INPUT : 730(W) SHF : 0.74

		OUTDOOR D.B.(°C)											
INDOOR D.B.(°C)	INDOOR W.B.(°C)	35				40				46			
		Q	SHC	SHF	INPUT	Q	SHC	SHF	INPUT	Q	SHC	SHF	INPUT
21	18	2.45	1.37	0.56	715	2.25	1.26	0.56	759	2.08	1.16	0.56	788
21	20	2.58	1.13	0.44	745	2.40	1.06	0.44	781	2.23	0.98	0.44	825
22	18	2.45	1.47	0.60	715	2.25	1.35	0.60	759	2.08	1.25	0.60	788
22	20	2.58	1.24	0.48	745	2.40	1.15	0.48	781	2.23	1.07	0.48	825
22	22	2.73	0.98	0.36	774	2.55	0.92	0.36	818	2.38	0.86	0.36	847
23	18	2.45	1.57	0.64	715	2.25	1.44	0.64	759	2.08	1.33	0.64	788
23	20	2.58	1.34	0.52	745	2.40	1.25	0.52	781	2.23	1.16	0.52	825
23	22	2.73	1.09	0.40	774	2.55	1.02	0.40	818	2.38	0.95	0.40	847
24	18	2.45	1.67	0.68	715	2.25	1.53	0.68	759	2.08	1.41	0.68	788
24	20	2.58	1.44	0.56	745	2.40	1.34	0.56	781	2.23	1.25	0.56	825
24	22	2.73	1.20	0.44	774	2.55	1.12	0.44	818	2.38	1.05	0.44	847
24	24	2.88	0.92	0.32	803	2.70	0.86	0.32	840	2.55	0.82	0.32	876
25	20	2.58	1.55	0.60	745	2.40	1.44	0.60	781	2.23	1.34	0.60	825
25	22	2.73	1.31	0.48	774	2.55	1.22	0.48	818	2.38	1.14	0.48	847
25	24	2.88	1.04	0.36	803	2.70	0.97	0.36	840	2.55	0.92	0.36	876
26	18	2.45	1.86	0.76	715	2.25	1.71	0.76	759	2.08	1.58	0.76	788
26	20	2.58	1.65	0.64	745	2.40	1.54	0.64	781	2.23	1.42	0.64	825
26	22	2.73	1.42	0.52	774	2.55	1.33	0.52	818	2.38	1.24	0.52	847
26	24	2.88	1.15	0.40	803	2.70	1.08	0.40	840	2.55	1.02	0.40	876
26	26	3.03	0.85	0.28	832	2.85	0.80	0.28	869	2.68	0.75	0.28	905
27	18	2.45	1.96	0.80	715	2.25	1.80	0.80	759	2.08	1.66	0.80	788
27	20	2.58	1.75	0.68	745	2.40	1.63	0.68	781	2.23	1.51	0.68	825
27	22	2.73	1.53	0.56	774	2.55	1.43	0.56	818	2.38	1.33	0.56	847
27	24	2.88	1.27	0.44	803	2.70	1.19	0.44	840	2.55	1.12	0.44	876
27	26	3.03	0.97	0.32	832	2.85	0.91	0.32	869	2.68	0.86	0.32	905
28	18	2.45	2.06	0.84	715	2.25	1.89	0.84	759	2.08	1.74	0.84	788
28	20	2.58	1.85	0.72	745	2.40	1.73	0.72	781	2.23	1.60	0.72	825
28	22	2.73	1.64	0.60	774	2.55	1.53	0.60	818	2.38	1.43	0.60	847
28	24	2.88	1.38	0.48	803	2.70	1.30	0.48	840	2.55	1.22	0.48	876
28	26	3.03	1.09	0.36	832	2.85	1.03	0.36	869	2.68	0.96	0.36	905
29	18	2.45	2.16	0.88	715	2.25	1.98	0.88	759	2.08	1.83	0.88	788
29	20	2.58	1.96	0.76	745	2.40	1.82	0.76	781	2.23	1.69	0.76	825
29	22	2.73	1.74	0.64	774	2.55	1.63	0.64	818	2.38	1.52	0.64	847
29	24	2.88	1.50	0.52	803	2.70	1.40	0.52	840	2.55	1.33	0.52	876
29	26	3.03	1.21	0.40	832	2.85	1.14	0.40	869	2.68	1.07	0.40	905
30	18	2.45	2.25	0.92	715	2.25	2.07	0.92	759	2.08	1.91	0.92	788
30	20	2.58	2.06	0.80	745	2.40	1.92	0.80	781	2.23	1.78	0.80	825
30	22	2.73	1.85	0.68	774	2.55	1.73	0.68	818	2.38	1.62	0.68	847
30	24	2.88	1.61	0.56	803	2.70	1.51	0.56	840	2.55	1.43	0.56	876
30	26	3.03	1.33	0.44	832	2.85	1.25	0.44	869	2.68	1.18	0.44	905
31	18	2.45	2.35	0.96	715	2.25	2.16	0.96	759	2.08	1.99	0.96	788
31	20	2.58	2.16	0.84	745	2.40	2.02	0.84	781	2.23	1.87	0.84	825
31	22	2.73	1.96	0.72	774	2.55	1.84	0.72	818	2.38	1.71	0.72	847
31	24	2.88	1.73	0.60	803	2.70	1.62	0.60	840	2.55	1.53	0.60	876
31	26	3.03	1.45	0.48	832	2.85	1.37	0.48	869	2.68	1.28	0.48	905
32	18	2.45	2.45	1.00	715	2.25	2.25	1.00	759	2.08	2.08	1.00	788
32	20	2.58	2.27	0.88	745	2.40	2.11	0.88	781	2.23	1.96	0.88	825
32	22	2.73	2.07	0.76	774	2.55	1.94	0.76	818	2.38	1.81	0.76	847
32	24	2.88	1.84	0.64	803	2.70	1.73	0.64	840	2.55	1.63	0.64	876
32	26	3.03	1.57	0.52	832	2.85	1.48	0.52	869	2.68	1.39	0.52	905

**NOTE** Q : Total capacity (kW) SHF : Sensible heat factor DB : Dry-bulb temperature  
 SHC : Sensible heat capacity (kW) INPUT : Total power input (W) WB : Wet-bulb temperature

**PERFORMANCE DATA**

**COOLING operation at Rated frequency**

**SEZ-KA35VA/SUZ-KA35VA(H)**

CAPACITY : 3.5(kW) INPUT : 1060(W) SHF : 0.77

		OUTDOOR D.B.(°C)															
INDOOR D.B.(°C)	INDOOR W.B.(°C)	21				25				27				30			
		Q	SHC	SHF	INPUT	Q	SHC	SHF	INPUT	Q	SHC	SHF	INPUT	Q	SHC	SHF	INPUT
21	18	4.11	2.43	0.59	848	3.94	2.32	0.59	890	3.78	2.23	0.59	933	3.64	2.15	0.59	975
21	20	4.29	2.02	0.47	890	4.11	1.93	0.47	943	3.99	1.88	0.47	965	3.85	1.81	0.47	1007
22	18	4.11	2.59	0.63	848	3.94	2.48	0.63	890	3.78	2.38	0.63	933	3.64	2.29	0.63	975
22	20	4.29	2.19	0.51	890	4.11	2.10	0.51	943	3.99	2.03	0.51	965	3.85	1.96	0.51	1007
22	22	4.46	1.74	0.39	922	4.31	1.68	0.39	981	4.20	1.64	0.39	1007	4.03	1.57	0.39	1049
23	18	4.11	2.76	0.67	848	3.94	2.64	0.67	890	3.78	2.53	0.67	933	3.64	2.44	0.67	975
23	20	4.29	2.36	0.55	890	4.11	2.26	0.55	943	3.99	2.19	0.55	965	3.85	2.12	0.55	1007
23	22	4.46	1.92	0.43	922	4.31	1.85	0.43	981	4.20	1.81	0.43	1007	4.03	1.73	0.43	1049
24	18	4.11	2.92	0.71	848	3.94	2.80	0.71	890	3.78	2.68	0.71	933	3.64	2.58	0.71	975
24	20	4.29	2.53	0.59	890	4.11	2.43	0.59	943	3.99	2.35	0.59	965	3.85	2.27	0.59	1007
24	22	4.46	2.10	0.47	922	4.31	2.02	0.47	981	4.20	1.97	0.47	1007	4.03	1.89	0.47	1049
24	24	4.69	1.64	0.35	965	4.52	1.58	0.35	1018	4.41	1.54	0.35	1049	4.27	1.49	0.35	1102
25	20	4.29	2.70	0.63	890	4.11	2.59	0.63	943	3.99	2.51	0.63	965	3.85	2.43	0.63	1007
25	22	4.46	2.28	0.51	922	4.31	2.20	0.51	981	4.20	2.14	0.51	1007	4.03	2.05	0.51	1049
25	24	4.69	1.83	0.39	965	4.52	1.76	0.39	1018	4.41	1.72	0.39	1049	4.27	1.67	0.39	1102
26	18	4.11	3.25	0.79	848	3.94	3.11	0.79	890	3.78	2.99	0.79	933	3.64	2.88	0.79	975
26	20	4.29	2.87	0.67	890	4.11	2.76	0.67	943	3.99	2.67	0.67	965	3.85	2.58	0.67	1007
26	22	4.46	2.45	0.55	922	4.31	2.37	0.55	981	4.20	2.31	0.55	1007	4.03	2.21	0.55	1049
26	24	4.69	2.02	0.43	965	4.52	1.94	0.43	1018	4.41	1.90	0.43	1049	4.27	1.84	0.43	1102
26	26	4.83	1.50	0.31	1018	4.69	1.45	0.31	1071	4.62	1.43	0.31	1102	4.48	1.39	0.31	1134
27	18	4.11	3.41	0.83	848	3.94	3.27	0.83	890	3.78	3.14	0.83	933	3.64	3.02	0.83	975
27	20	4.29	3.04	0.71	890	4.11	2.92	0.71	943	3.99	2.83	0.71	965	3.85	2.73	0.71	1007
27	22	4.46	2.63	0.59	922	4.31	2.54	0.59	981	4.20	2.48	0.59	1007	4.03	2.37	0.59	1049
27	24	4.69	2.20	0.47	965	4.52	2.12	0.47	1018	4.41	2.07	0.47	1049	4.27	2.01	0.47	1102
27	26	4.83	1.69	0.35	1018	4.69	1.64	0.35	1071	4.62	1.62	0.35	1102	4.48	1.57	0.35	1134
28	18	4.11	3.58	0.87	848	3.94	3.43	0.87	890	3.78	3.29	0.87	933	3.64	3.17	0.87	975
28	20	4.29	3.22	0.75	890	4.11	3.08	0.75	943	3.99	2.99	0.75	965	3.85	2.89	0.75	1007
28	22	4.46	2.81	0.63	922	4.31	2.71	0.63	981	4.20	2.65	0.63	1007	4.03	2.54	0.63	1049
28	24	4.69	2.39	0.51	965	4.52	2.30	0.51	1018	4.41	2.25	0.51	1049	4.27	2.18	0.51	1102
28	26	4.83	1.88	0.39	1018	4.69	1.83	0.39	1071	4.62	1.80	0.39	1102	4.48	1.75	0.39	1134
29	18	4.11	3.74	0.91	848	3.94	3.58	0.91	890	3.78	3.44	0.91	933	3.64	3.31	0.91	975
29	20	4.29	3.39	0.79	890	4.11	3.25	0.79	943	3.99	3.15	0.79	965	3.85	3.04	0.79	1007
29	22	4.46	2.99	0.67	922	4.31	2.88	0.67	981	4.20	2.81	0.67	1007	4.03	2.70	0.67	1049
29	24	4.69	2.58	0.55	965	4.52	2.48	0.55	1018	4.41	2.43	0.55	1049	4.27	2.35	0.55	1102
29	26	4.83	2.08	0.43	1018	4.69	2.02	0.43	1071	4.62	1.99	0.43	1102	4.48	1.93	0.43	1134
30	18	4.11	3.91	0.95	848	3.94	3.74	0.95	890	3.78	3.59	0.95	933	3.64	3.46	0.95	975
30	20	4.29	3.56	0.83	890	4.11	3.41	0.83	943	3.99	3.31	0.83	965	3.85	3.20	0.83	1007
30	22	4.46	3.17	0.71	922	4.31	3.06	0.71	981	4.20	2.98	0.71	1007	4.03	2.86	0.71	1049
30	24	4.69	2.77	0.59	965	4.52	2.66	0.59	1018	4.41	2.60	0.59	1049	4.27	2.52	0.59	1102
30	26	4.83	2.27	0.47	1018	4.69	2.20	0.47	1071	4.62	2.17	0.47	1102	4.48	2.11	0.47	1134
31	18	4.11	4.07	0.99	848	3.94	3.90	0.99	890	3.78	3.74	0.99	933	3.64	3.60	0.99	975
31	20	4.29	3.73	0.87	890	4.11	3.58	0.87	943	3.99	3.47	0.87	965	3.85	3.35	0.87	1007
31	22	4.46	3.35	0.75	922	4.31	3.23	0.75	981	4.20	3.15	0.75	1007	4.03	3.02	0.75	1049
31	24	4.69	2.95	0.63	965	4.52	2.84	0.63	1018	4.41	2.78	0.63	1049	4.27	2.69	0.63	1102
31	26	4.83	2.46	0.51	1018	4.69	2.39	0.51	1071	4.62	2.36	0.51	1102	4.48	2.28	0.51	1134
32	18	4.11	4.11	1.00	848	3.94	3.94	1.00	890	3.78	3.78	1.00	933	3.64	3.64	1.00	975
32	20	4.29	3.90	0.91	890	4.11	3.74	0.91	943	3.99	3.63	0.91	965	3.85	3.50	0.91	1007
32	22	4.46	3.53	0.79	922	4.31	3.40	0.79	981	4.20	3.32	0.79	1007	4.03	3.18	0.79	1049
32	24	4.69	3.14	0.67	965	4.52	3.03	0.67	1018	4.41	2.95	0.67	1049	4.27	2.86	0.67	1102
32	26	4.83	2.66	0.55	1018	4.69	2.58	0.55	1071	4.62	2.54	0.55	1102	4.48	2.46	0.55	1134

**NOTE** Q : Total capacity (kW) SHF : Sensible heat factor DB : Dry-bulb temperature  
 SHC : Sensible heat capacity (kW) INPUT : Total power input (W) WB : Wet-bulb temperature

**PERFORMANCE DATA**

**COOLING operation at Rated frequency**

**SEZ-KA35VA/SUZ-KA35VA(H)**

CAPACITY : 3.5(kW) INPUT : 1060(W) SHF : 0.77

		OUTDOOR D.B.(°C)											
INDOOR D.B.(°C)	INDOOR W.B.(°C)	35				40				46			
		Q	SHC	SHF	INPUT	Q	SHC	SHF	INPUT	Q	SHC	SHF	INPUT
21	18	3.43	2.02	0.59	1039	3.15	1.86	0.59	1102	2.91	1.71	0.59	1145
21	20	3.61	1.69	0.47	1081	3.36	1.58	0.47	1134	3.12	1.46	0.47	1198
22	18	3.43	2.16	0.63	1039	3.15	1.98	0.63	1102	2.91	1.83	0.63	1145
22	20	3.61	1.84	0.51	1081	3.36	1.71	0.51	1134	3.12	1.59	0.51	1198
22	22	3.82	1.49	0.39	1124	3.57	1.39	0.39	1187	3.33	1.30	0.39	1230
23	18	3.43	2.30	0.67	1039	3.15	2.11	0.67	1102	2.91	1.95	0.67	1145
23	20	3.61	1.98	0.55	1081	3.36	1.85	0.55	1134	3.12	1.71	0.55	1198
23	22	3.82	1.64	0.43	1124	3.57	1.54	0.43	1187	3.33	1.43	0.43	1230
24	18	3.43	2.44	0.71	1039	3.15	2.24	0.71	1102	2.91	2.06	0.71	1145
24	20	3.61	2.13	0.59	1081	3.36	1.98	0.59	1134	3.12	1.84	0.59	1198
24	22	3.82	1.79	0.47	1124	3.57	1.68	0.47	1187	3.33	1.56	0.47	1230
24	24	4.03	1.41	0.35	1166	3.78	1.32	0.35	1219	3.57	1.25	0.35	1272
25	20	3.61	2.27	0.63	1081	3.36	2.12	0.63	1134	3.12	1.96	0.63	1198
25	22	3.82	1.95	0.51	1124	3.57	1.82	0.51	1187	3.33	1.70	0.51	1230
25	24	4.03	1.57	0.39	1166	3.78	1.47	0.39	1219	3.57	1.39	0.39	1272
26	18	3.43	2.71	0.79	1039	3.15	2.49	0.79	1102	2.91	2.29	0.79	1145
26	20	3.61	2.42	0.67	1081	3.36	2.25	0.67	1134	3.12	2.09	0.67	1198
26	22	3.82	2.10	0.55	1124	3.57	1.96	0.55	1187	3.33	1.83	0.55	1230
26	24	4.03	1.73	0.43	1166	3.78	1.63	0.43	1219	3.57	1.54	0.43	1272
26	26	4.24	1.31	0.31	1208	3.99	1.24	0.31	1261	3.75	1.16	0.31	1314
27	18	3.43	2.85	0.83	1039	3.15	2.61	0.83	1102	2.91	2.41	0.83	1145
27	20	3.61	2.56	0.71	1081	3.36	2.39	0.71	1134	3.12	2.21	0.71	1198
27	22	3.82	2.25	0.59	1124	3.57	2.11	0.59	1187	3.33	1.96	0.59	1230
27	24	4.03	1.89	0.47	1166	3.78	1.78	0.47	1219	3.57	1.68	0.47	1272
27	26	4.24	1.48	0.35	1208	3.99	1.40	0.35	1261	3.75	1.31	0.35	1314
28	18	3.43	2.98	0.87	1039	3.15	2.74	0.87	1102	2.91	2.53	0.87	1145
28	20	3.61	2.70	0.75	1081	3.36	2.52	0.75	1134	3.12	2.34	0.75	1198
28	22	3.82	2.40	0.63	1124	3.57	2.25	0.63	1187	3.33	2.09	0.63	1230
28	24	4.03	2.05	0.51	1166	3.78	1.93	0.51	1219	3.57	1.82	0.51	1272
28	26	4.24	1.65	0.39	1208	3.99	1.56	0.39	1261	3.75	1.46	0.39	1314
29	18	3.43	3.12	0.91	1039	3.15	2.87	0.91	1102	2.91	2.64	0.91	1145
29	20	3.61	2.85	0.79	1081	3.36	2.65	0.79	1134	3.12	2.46	0.79	1198
29	22	3.82	2.56	0.67	1124	3.57	2.39	0.67	1187	3.33	2.23	0.67	1230
29	24	4.03	2.21	0.55	1166	3.78	2.08	0.55	1219	3.57	1.96	0.55	1272
29	26	4.24	1.82	0.43	1208	3.99	1.72	0.43	1261	3.75	1.61	0.43	1314
30	18	3.43	3.26	0.95	1039	3.15	2.99	0.95	1102	2.91	2.76	0.95	1145
30	20	3.61	2.99	0.83	1081	3.36	2.79	0.83	1134	3.12	2.59	0.83	1198
30	22	3.82	2.71	0.71	1124	3.57	2.53	0.71	1187	3.33	2.36	0.71	1230
30	24	4.03	2.37	0.59	1166	3.78	2.23	0.59	1219	3.57	2.11	0.59	1272
30	26	4.24	1.99	0.47	1208	3.99	1.88	0.47	1261	3.75	1.76	0.47	1314
31	18	3.43	3.40	0.99	1039	3.15	3.12	0.99	1102	2.91	2.88	0.99	1145
31	20	3.61	3.14	0.87	1081	3.36	2.92	0.87	1134	3.12	2.71	0.87	1198
31	22	3.82	2.86	0.75	1124	3.57	2.68	0.75	1187	3.33	2.49	0.75	1230
31	24	4.03	2.54	0.63	1166	3.78	2.38	0.63	1219	3.57	2.25	0.63	1272
31	26	4.24	2.16	0.51	1208	3.99	2.03	0.51	1261	3.75	1.91	0.51	1314
32	18	3.43	3.43	1.00	1039	3.15	3.15	1.00	1102	2.91	2.91	1.00	1145
32	20	3.61	3.28	0.91	1081	3.36	3.06	0.91	1134	3.12	2.83	0.91	1198
32	22	3.82	3.01	0.79	1124	3.57	2.82	0.79	1187	3.33	2.63	0.79	1230
32	24	4.03	2.70	0.67	1166	3.78	2.53	0.67	1219	3.57	2.39	0.67	1272
32	26	4.24	2.33	0.55	1208	3.99	2.19	0.55	1261	3.75	2.06	0.55	1314

**NOTE** Q : Total capacity (kW) SHF : Sensible heat factor DB : Dry-bulb temperature  
 SHC : Sensible heat capacity (kW) INPUT : Total power input (W) WB : Wet-bulb temperature



**PERFORMANCE DATA**

**COOLING operation at Rated frequency**

**SEZ-KA50VA/SUZ-KA50VA**

CAPACITY : 5.0(kW) INPUT : 1780(W) SHF : 0.75

		OUTDOOR D.B.(°C)															
INDOOR D.B.(°C)	INDOOR W.B.(°C)	21				25				27				30			
		Q	SHC	SHF	INPUT	Q	SHC	SHF	INPUT	Q	SHC	SHF	INPUT	Q	SHC	SHF	INPUT
21	18	5.88	3.35	0.57	1424	5.63	3.21	0.57	1495	5.40	3.08	0.57	1566	5.20	2.96	0.57	1638
21	20	6.13	2.76	0.45	1495	5.88	2.64	0.45	1584	5.70	2.57	0.45	1620	5.50	2.48	0.45	1691
22	18	5.88	3.58	0.61	1424	5.63	3.43	0.61	1495	5.40	3.29	0.61	1566	5.20	3.17	0.61	1638
22	20	6.13	3.00	0.49	1495	5.88	2.88	0.49	1584	5.70	2.79	0.49	1620	5.50	2.70	0.49	1691
22	22	6.38	2.36	0.37	1549	6.15	2.28	0.37	1647	6.00	2.22	0.37	1691	5.75	2.13	0.37	1762
23	18	5.88	3.82	0.65	1424	5.63	3.66	0.65	1495	5.40	3.51	0.65	1566	5.20	3.38	0.65	1638
23	20	6.13	3.25	0.53	1495	5.88	3.11	0.53	1584	5.70	3.02	0.53	1620	5.50	2.92	0.53	1691
23	22	6.38	2.61	0.41	1549	6.15	2.52	0.41	1647	6.00	2.46	0.41	1691	5.75	2.36	0.41	1762
24	18	5.88	4.05	0.69	1424	5.63	3.88	0.69	1495	5.40	3.73	0.69	1566	5.20	3.59	0.69	1638
24	20	6.13	3.49	0.57	1495	5.88	3.35	0.57	1584	5.70	3.25	0.57	1620	5.50	3.14	0.57	1691
24	22	6.38	2.87	0.45	1549	6.15	2.77	0.45	1647	6.00	2.70	0.45	1691	5.75	2.59	0.45	1762
24	24	6.70	2.21	0.33	1620	6.45	2.13	0.33	1709	6.30	2.08	0.33	1762	6.10	2.01	0.33	1851
25	20	6.13	3.74	0.61	1495	5.88	3.58	0.61	1584	5.70	3.48	0.61	1620	5.50	3.36	0.61	1691
25	22	6.38	3.12	0.49	1549	6.15	3.01	0.49	1647	6.00	2.94	0.49	1691	5.75	2.82	0.49	1762
25	24	6.70	2.48	0.37	1620	6.45	2.39	0.37	1709	6.30	2.33	0.37	1762	6.10	2.26	0.37	1851
26	18	5.88	4.52	0.77	1424	5.63	4.33	0.77	1495	5.40	4.16	0.77	1566	5.20	4.00	0.77	1638
26	20	6.13	3.98	0.65	1495	5.88	3.82	0.65	1584	5.70	3.71	0.65	1620	5.50	3.58	0.65	1691
26	22	6.38	3.38	0.53	1549	6.15	3.26	0.53	1647	6.00	3.18	0.53	1691	5.75	3.05	0.53	1762
26	24	6.70	2.75	0.41	1620	6.45	2.64	0.41	1709	6.30	2.58	0.41	1762	6.10	2.50	0.41	1851
26	26	6.90	2.00	0.29	1709	6.70	1.94	0.29	1798	6.60	1.91	0.29	1851	6.40	1.86	0.29	1905
27	18	5.88	4.76	0.81	1424	5.63	4.56	0.81	1495	5.40	4.37	0.81	1566	5.20	4.21	0.81	1638
27	20	6.13	4.23	0.69	1495	5.88	4.05	0.69	1584	5.70	3.93	0.69	1620	5.50	3.80	0.69	1691
27	22	6.38	3.63	0.57	1549	6.15	3.51	0.57	1647	6.00	3.42	0.57	1691	5.75	3.28	0.57	1762
27	24	6.70	3.02	0.45	1620	6.45	2.90	0.45	1709	6.30	2.84	0.45	1762	6.10	2.75	0.45	1851
27	26	6.90	2.28	0.33	1709	6.70	2.21	0.33	1798	6.60	2.18	0.33	1851	6.40	2.11	0.33	1905
28	18	5.88	4.99	0.85	1424	5.63	4.78	0.85	1495	5.40	4.59	0.85	1566	5.20	4.42	0.85	1638
28	20	6.13	4.47	0.73	1495	5.88	4.29	0.73	1584	5.70	4.16	0.73	1620	5.50	4.02	0.73	1691
28	22	6.38	3.89	0.61	1549	6.15	3.75	0.61	1647	6.00	3.66	0.61	1691	5.75	3.51	0.61	1762
28	24	6.70	3.28	0.49	1620	6.45	3.16	0.49	1709	6.30	3.09	0.49	1762	6.10	2.99	0.49	1851
28	26	6.90	2.55	0.37	1709	6.70	2.48	0.37	1798	6.60	2.44	0.37	1851	6.40	2.37	0.37	1905
29	18	5.88	5.23	0.89	1424	5.63	5.01	0.89	1495	5.40	4.81	0.89	1566	5.20	4.63	0.89	1638
29	20	6.13	4.72	0.77	1495	5.88	4.52	0.77	1584	5.70	4.39	0.77	1620	5.50	4.24	0.77	1691
29	22	6.38	4.14	0.65	1549	6.15	4.00	0.65	1647	6.00	3.90	0.65	1691	5.75	3.74	0.65	1762
29	24	6.70	3.55	0.53	1620	6.45	3.42	0.53	1709	6.30	3.34	0.53	1762	6.10	3.23	0.53	1851
29	26	6.90	2.83	0.41	1709	6.70	2.75	0.41	1798	6.60	2.71	0.41	1851	6.40	2.62	0.41	1905
30	18	5.88	5.46	0.93	1424	5.63	5.23	0.93	1495	5.40	5.02	0.93	1566	5.20	4.84	0.93	1638
30	20	6.13	4.96	0.81	1495	5.88	4.76	0.81	1584	5.70	4.62	0.81	1620	5.50	4.46	0.81	1691
30	22	6.38	4.40	0.69	1549	6.15	4.24	0.69	1647	6.00	4.14	0.69	1691	5.75	3.97	0.69	1762
30	24	6.70	3.82	0.57	1620	6.45	3.68	0.57	1709	6.30	3.59	0.57	1762	6.10	3.48	0.57	1851
30	26	6.90	3.11	0.45	1709	6.70	3.02	0.45	1798	6.60	2.97	0.45	1851	6.40	2.88	0.45	1905
31	18	5.88	5.70	0.97	1424	5.63	5.46	0.97	1495	5.40	5.24	0.97	1566	5.20	5.04	0.97	1638
31	20	6.13	5.21	0.85	1495	5.88	4.99	0.85	1584	5.70	4.85	0.85	1620	5.50	4.68	0.85	1691
31	22	6.38	4.65	0.73	1549	6.15	4.49	0.73	1647	6.00	4.38	0.73	1691	5.75	4.20	0.73	1762
31	24	6.70	4.09	0.61	1620	6.45	3.93	0.61	1709	6.30	3.84	0.61	1762	6.10	3.72	0.61	1851
31	26	6.90	3.38	0.49	1709	6.70	3.28	0.49	1798	6.60	3.23	0.49	1851	6.40	3.14	0.49	1905
32	18	5.88	5.88	1.00	1424	5.63	5.63	1.00	1495	5.40	5.40	1.00	1566	5.20	5.20	1.00	1638
32	20	6.13	5.45	0.89	1495	5.88	5.23	0.89	1584	5.70	5.07	0.89	1620	5.50	4.90	0.89	1691
32	22	6.38	4.91	0.77	1549	6.15	4.74	0.77	1647	6.00	4.62	0.77	1691	5.75	4.43	0.77	1762
32	24	6.70	4.36	0.65	1620	6.45	4.19	0.65	1709	6.30	4.10	0.65	1762	6.10	3.97	0.65	1851
32	26	6.90	3.66	0.53	1709	6.70	3.55	0.53	1798	6.60	3.50	0.53	1851	6.40	3.39	0.53	1905

**NOTE** Q : Total capacity (kW) SHF : Sensible heat factor DB : Dry-bulb temperature  
 SHC : Sensible heat capacity (kW) INPUT : Total power input (W) WB : Wet-bulb temperature

**PERFORMANCE DATA**

**COOLING operation at Rated frequency**

**SEZ-KA50VA/SUZ-KA50VA**

CAPACITY : 5.0(kW) INPUT : 1780(W) SHF : 0.75

		OUTDOOR D.B.(°C)											
INDOOR D.B.(°C)	INDOOR W.B.(°C)	35				40				46			
		Q	SHC	SHF	INPUT	Q	SHC	SHF	INPUT	Q	SHC	SHF	INPUT
21	18	4.90	2.79	0.57	1744	4.50	2.57	0.57	1851	4.15	2.37	0.57	1922
21	20	5.15	2.32	0.45	1816	4.80	2.16	0.45	1905	4.45	2.00	0.45	2011
22	18	4.90	2.99	0.61	1744	4.50	2.75	0.61	1851	4.15	2.53	0.61	1922
22	20	5.15	2.52	0.49	1816	4.80	2.35	0.49	1905	4.45	2.18	0.49	2011
22	22	5.45	2.02	0.37	1887	5.10	1.89	0.37	1994	4.75	1.76	0.37	2065
23	18	4.90	3.19	0.65	1744	4.50	2.93	0.65	1851	4.15	2.70	0.65	1922
23	20	5.15	2.73	0.53	1816	4.80	2.54	0.53	1905	4.45	2.36	0.53	2011
23	22	5.45	2.23	0.41	1887	5.10	2.09	0.41	1994	4.75	1.95	0.41	2065
24	18	4.90	3.38	0.69	1744	4.50	3.11	0.69	1851	4.15	2.86	0.69	1922
24	20	5.15	2.94	0.57	1816	4.80	2.74	0.57	1905	4.45	2.54	0.57	2011
24	22	5.45	2.45	0.45	1887	5.10	2.30	0.45	1994	4.75	2.14	0.45	2065
24	24	5.75	1.90	0.33	1958	5.40	1.78	0.33	2047	5.10	1.68	0.33	2136
25	20	5.15	3.14	0.61	1816	4.80	2.93	0.61	1905	4.45	2.71	0.61	2011
25	22	5.45	2.67	0.49	1887	5.10	2.50	0.49	1994	4.75	2.33	0.49	2065
25	24	5.75	2.13	0.37	1958	5.40	2.00	0.37	2047	5.10	1.89	0.37	2136
26	18	4.90	3.77	0.77	1744	4.50	3.47	0.77	1851	4.15	3.20	0.77	1922
26	20	5.15	3.35	0.65	1816	4.80	3.12	0.65	1905	4.45	2.89	0.65	2011
26	22	5.45	2.89	0.53	1887	5.10	2.70	0.53	1994	4.75	2.52	0.53	2065
26	24	5.75	2.36	0.41	1958	5.40	2.21	0.41	2047	5.10	2.09	0.41	2136
26	26	6.05	1.75	0.29	2029	5.70	1.65	0.29	2118	5.35	1.55	0.29	2207
27	18	4.90	3.97	0.81	1744	4.50	3.65	0.81	1851	4.15	3.36	0.81	1922
27	20	5.15	3.55	0.69	1816	4.80	3.31	0.69	1905	4.45	3.07	0.69	2011
27	22	5.45	3.11	0.57	1887	5.10	2.91	0.57	1994	4.75	2.71	0.57	2065
27	24	5.75	2.59	0.45	1958	5.40	2.43	0.45	2047	5.10	2.30	0.45	2136
27	26	6.05	2.00	0.33	2029	5.70	1.88	0.33	2118	5.35	1.77	0.33	2207
28	18	4.90	4.17	0.85	1744	4.50	3.83	0.85	1851	4.15	3.53	0.85	1922
28	20	5.15	3.76	0.73	1816	4.80	3.50	0.73	1905	4.45	3.25	0.73	2011
28	22	5.45	3.32	0.61	1887	5.10	3.11	0.61	1994	4.75	2.90	0.61	2065
28	24	5.75	2.82	0.49	1958	5.40	2.65	0.49	2047	5.10	2.50	0.49	2136
28	26	6.05	2.24	0.37	2029	5.70	2.11	0.37	2118	5.35	1.98	0.37	2207
29	18	4.90	4.36	0.89	1744	4.50	4.01	0.89	1851	4.15	3.69	0.89	1922
29	20	5.15	3.97	0.77	1816	4.80	3.70	0.77	1905	4.45	3.43	0.77	2011
29	22	5.45	3.54	0.65	1887	5.10	3.32	0.65	1994	4.75	3.09	0.65	2065
29	24	5.75	3.05	0.53	1958	5.40	2.86	0.53	2047	5.10	2.70	0.53	2136
29	26	6.05	2.48	0.41	2029	5.70	2.34	0.41	2118	5.35	2.19	0.41	2207
30	18	4.90	4.56	0.93	1744	4.50	4.19	0.93	1851	4.15	3.86	0.93	1922
30	20	5.15	4.17	0.81	1816	4.80	3.89	0.81	1905	4.45	3.60	0.81	2011
30	22	5.45	3.76	0.69	1887	5.10	3.52	0.69	1994	4.75	3.28	0.69	2065
30	24	5.75	3.28	0.57	1958	5.40	3.08	0.57	2047	5.10	2.91	0.57	2136
30	26	6.05	2.72	0.45	2029	5.70	2.57	0.45	2118	5.35	2.41	0.45	2207
31	18	4.90	4.75	0.97	1744	4.50	4.37	0.97	1851	4.15	4.03	0.97	1922
31	20	5.15	4.38	0.85	1816	4.80	4.08	0.85	1905	4.45	3.78	0.85	2011
31	22	5.45	3.98	0.73	1887	5.10	3.72	0.73	1994	4.75	3.47	0.73	2065
31	24	5.75	3.51	0.61	1958	5.40	3.29	0.61	2047	5.10	3.11	0.61	2136
31	26	6.05	2.96	0.49	2029	5.70	2.79	0.49	2118	5.35	2.62	0.49	2207
32	18	4.90	4.90	1.00	1744	4.50	4.50	1.00	1851	4.15	4.15	1.00	1922
32	20	5.15	4.58	0.89	1816	4.80	4.27	0.89	1905	4.45	3.96	0.89	2011
32	22	5.45	4.20	0.77	1887	5.10	3.93	0.77	1994	4.75	3.66	0.77	2065
32	24	5.75	3.74	0.65	1958	5.40	3.51	0.65	2047	5.10	3.32	0.65	2136
32	26	6.05	3.21	0.53	2029	5.70	3.02	0.53	2118	5.35	2.84	0.53	2207

**NOTE** Q : Total capacity (kW) SHF : Sensible heat factor DB : Dry-bulb temperature  
 SHC : Sensible heat capacity (kW) INPUT : Total power input (W) WB : Wet-bulb temperature

**PERFORMANCE DATA**

**COOLING operation at Rated frequency**

**SEZ-KA60VA/SUZ-KA60VA**

CAPACITY : 5.5(kW) INPUT : 1960(W) SHF : 0.75

		OUTDOOR D.B.(°C)															
INDOOR D.B.(°C)	INDOOR W.B.(°C)	21				25				27				30			
		Q	SHC	SHF	INPUT	Q	SHC	SHF	INPUT	Q	SHC	SHF	INPUT	Q	SHC	SHF	INPUT
21	18	6.46	3.68	0.57	1568	6.19	3.53	0.57	1646	5.94	3.39	0.57	1725	5.72	3.26	0.57	1803
21	20	6.74	3.03	0.45	1646	6.46	2.91	0.45	1744	6.27	2.82	0.45	1784	6.05	2.72	0.45	1862
22	18	6.46	3.94	0.61	1568	6.19	3.77	0.61	1646	5.94	3.62	0.61	1725	5.72	3.49	0.61	1803
22	20	6.74	3.30	0.49	1646	6.46	3.17	0.49	1744	6.27	3.07	0.49	1784	6.05	2.96	0.49	1862
22	22	7.01	2.59	0.37	1705	6.77	2.50	0.37	1813	6.60	2.44	0.37	1862	6.33	2.34	0.37	1940
23	18	6.46	4.20	0.65	1568	6.19	4.02	0.65	1646	5.94	3.86	0.65	1725	5.72	3.72	0.65	1803
23	20	6.74	3.57	0.53	1646	6.46	3.43	0.53	1744	6.27	3.32	0.53	1784	6.05	3.21	0.53	1862
23	22	7.01	2.88	0.41	1705	6.77	2.77	0.41	1813	6.60	2.71	0.41	1862	6.33	2.59	0.41	1940
24	18	6.46	4.46	0.69	1568	6.19	4.27	0.69	1646	5.94	4.10	0.69	1725	5.72	3.95	0.69	1803
24	20	6.74	3.84	0.57	1646	6.46	3.68	0.57	1744	6.27	3.57	0.57	1784	6.05	3.45	0.57	1862
24	22	7.01	3.16	0.45	1705	6.77	3.04	0.45	1813	6.60	2.97	0.45	1862	6.33	2.85	0.45	1940
24	24	7.37	2.43	0.33	1784	7.10	2.34	0.33	1882	6.93	2.29	0.33	1940	6.71	2.21	0.33	2038
25	20	6.74	4.11	0.61	1646	6.46	3.94	0.61	1744	6.27	3.82	0.61	1784	6.05	3.69	0.61	1862
25	22	7.01	3.44	0.49	1705	6.77	3.31	0.49	1813	6.60	3.23	0.49	1862	6.33	3.10	0.49	1940
25	24	7.37	2.73	0.37	1784	7.10	2.63	0.37	1882	6.93	2.56	0.37	1940	6.71	2.48	0.37	2038
26	18	6.46	4.98	0.77	1568	6.19	4.76	0.77	1646	5.94	4.57	0.77	1725	5.72	4.40	0.77	1803
26	20	6.74	4.38	0.65	1646	6.46	4.20	0.65	1744	6.27	4.08	0.65	1784	6.05	3.93	0.65	1862
26	22	7.01	3.72	0.53	1705	6.77	3.59	0.53	1813	6.60	3.50	0.53	1862	6.33	3.35	0.53	1940
26	24	7.37	3.02	0.41	1784	7.10	2.91	0.41	1882	6.93	2.84	0.41	1940	6.71	2.75	0.41	2038
26	26	7.59	2.20	0.29	1882	7.37	2.14	0.29	1980	7.26	2.11	0.29	2038	7.04	2.04	0.29	2097
27	18	6.46	5.23	0.81	1568	6.19	5.01	0.81	1646	5.94	4.81	0.81	1725	5.72	4.63	0.81	1803
27	20	6.74	4.65	0.69	1646	6.46	4.46	0.69	1744	6.27	4.33	0.69	1784	6.05	4.17	0.69	1862
27	22	7.01	4.00	0.57	1705	6.77	3.86	0.57	1813	6.60	3.76	0.57	1862	6.33	3.61	0.57	1940
27	24	7.37	3.32	0.45	1784	7.10	3.19	0.45	1882	6.93	3.12	0.45	1940	6.71	3.02	0.45	2038
27	26	7.59	2.50	0.33	1882	7.37	2.43	0.33	1980	7.26	2.40	0.33	2038	7.04	2.32	0.33	2097
28	18	6.46	5.49	0.85	1568	6.19	5.26	0.85	1646	5.94	5.05	0.85	1725	5.72	4.86	0.85	1803
28	20	6.74	4.92	0.73	1646	6.46	4.72	0.73	1744	6.27	4.58	0.73	1784	6.05	4.42	0.73	1862
28	22	7.01	4.28	0.61	1705	6.77	4.13	0.61	1813	6.60	4.03	0.61	1862	6.33	3.86	0.61	1940
28	24	7.37	3.61	0.49	1784	7.10	3.48	0.49	1882	6.93	3.40	0.49	1940	6.71	3.29	0.49	2038
28	26	7.59	2.81	0.37	1882	7.37	2.73	0.37	1980	7.26	2.69	0.37	2038	7.04	2.60	0.37	2097
29	18	6.46	5.75	0.89	1568	6.19	5.51	0.89	1646	5.94	5.29	0.89	1725	5.72	5.09	0.89	1803
29	20	6.74	5.19	0.77	1646	6.46	4.98	0.77	1744	6.27	4.83	0.77	1784	6.05	4.66	0.77	1862
29	22	7.01	4.56	0.65	1705	6.77	4.40	0.65	1813	6.60	4.29	0.65	1862	6.33	4.11	0.65	1940
29	24	7.37	3.91	0.53	1784	7.10	3.76	0.53	1882	6.93	3.67	0.53	1940	6.71	3.56	0.53	2038
29	26	7.59	3.11	0.41	1882	7.37	3.02	0.41	1980	7.26	2.98	0.41	2038	7.04	2.89	0.41	2097
30	18	6.46	6.01	0.93	1568	6.19	5.75	0.93	1646	5.94	5.52	0.93	1725	5.72	5.32	0.93	1803
30	20	6.74	5.46	0.81	1646	6.46	5.23	0.81	1744	6.27	5.08	0.81	1784	6.05	4.90	0.81	1862
30	22	7.01	4.84	0.69	1705	6.77	4.67	0.69	1813	6.60	4.55	0.69	1862	6.33	4.36	0.69	1940
30	24	7.37	4.20	0.57	1784	7.10	4.04	0.57	1882	6.93	3.95	0.57	1940	6.71	3.82	0.57	2038
30	26	7.59	3.42	0.45	1882	7.37	3.32	0.45	1980	7.26	3.27	0.45	2038	7.04	3.17	0.45	2097
31	18	6.46	6.27	0.97	1568	6.19	6.00	0.97	1646	5.94	5.76	0.97	1725	5.72	5.55	0.97	1803
31	20	6.74	5.73	0.85	1646	6.46	5.49	0.85	1744	6.27	5.33	0.85	1784	6.05	5.14	0.85	1862
31	22	7.01	5.12	0.73	1705	6.77	4.94	0.73	1813	6.60	4.82	0.73	1862	6.33	4.62	0.73	1940
31	24	7.37	4.50	0.61	1784	7.10	4.33	0.61	1882	6.93	4.23	0.61	1940	6.71	4.09	0.61	2038
31	26	7.59	3.72	0.49	1882	7.37	3.61	0.49	1980	7.26	3.56	0.49	2038	7.04	3.45	0.49	2097
32	18	6.46	6.46	1.00	1568	6.19	6.19	1.00	1646	5.94	5.94	1.00	1725	5.72	5.72	1.00	1803
32	20	6.74	6.00	0.89	1646	6.46	5.75	0.89	1744	6.27	5.58	0.89	1784	6.05	5.38	0.89	1862
32	22	7.01	5.40	0.77	1705	6.77	5.21	0.77	1813	6.60	5.08	0.77	1862	6.33	4.87	0.77	1940
32	24	7.37	4.79	0.65	1784	7.10	4.61	0.65	1882	6.93	4.50	0.65	1940	6.71	4.36	0.65	2038
32	26	7.59	4.02	0.53	1882	7.37	3.91	0.53	1980	7.26	3.85	0.53	2038	7.04	3.73	0.53	2097

**NOTE** Q : Total capacity (kW) SHF : Sensible heat factor DB : Dry-bulb temperature  
 SHC : Sensible heat capacity (kW) INPUT : Total power input (W) WB : Wet-bulb temperature

**PERFORMANCE DATA**

**COOLING operation at Rated frequency**

**SEZ-KA60VA/SUZ-KA60VA**

CAPACITY : 5.5(kW) INPUT : 1960(W) SHF : 0.75

		OUTDOOR D.B.(°C)											
INDOOR D.B.(°C)	INDOOR W.B.(°C)	35				40				46			
		Q	SHC	SHF	INPUT	Q	SHC	SHF	INPUT	Q	SHC	SHF	INPUT
21	18	5.39	3.07	0.57	1921	4.95	2.82	0.57	2038	4.57	2.60	0.57	2117
21	20	5.67	2.55	0.45	1999	5.28	2.38	0.45	2097	4.90	2.20	0.45	2215
22	18	5.39	3.29	0.61	1921	4.95	3.02	0.61	2038	4.57	2.78	0.61	2117
22	20	5.67	2.78	0.49	1999	5.28	2.59	0.49	2097	4.90	2.40	0.49	2215
22	22	6.00	2.22	0.37	2078	5.61	2.08	0.37	2195	5.23	1.93	0.37	2274
23	18	5.39	3.50	0.65	1921	4.95	3.22	0.65	2038	4.57	2.97	0.65	2117
23	20	5.67	3.00	0.53	1999	5.28	2.80	0.53	2097	4.90	2.59	0.53	2215
23	22	6.00	2.46	0.41	2078	5.61	2.30	0.41	2195	5.23	2.14	0.41	2274
24	18	5.39	3.72	0.69	1921	4.95	3.42	0.69	2038	4.57	3.15	0.69	2117
24	20	5.67	3.23	0.57	1999	5.28	3.01	0.57	2097	4.90	2.79	0.57	2215
24	22	6.00	2.70	0.45	2078	5.61	2.52	0.45	2195	5.23	2.35	0.45	2274
24	24	6.33	2.09	0.33	2156	5.94	1.96	0.33	2254	5.61	1.85	0.33	2352
25	20	5.67	3.46	0.61	1999	5.28	3.22	0.61	2097	4.90	2.99	0.61	2215
25	22	6.00	2.94	0.49	2078	5.61	2.75	0.49	2195	5.23	2.56	0.49	2274
25	24	6.33	2.34	0.37	2156	5.94	2.20	0.37	2254	5.61	2.08	0.37	2352
26	18	5.39	4.15	0.77	1921	4.95	3.81	0.77	2038	4.57	3.52	0.77	2117
26	20	5.67	3.68	0.65	1999	5.28	3.43	0.65	2097	4.90	3.18	0.65	2215
26	22	6.00	3.18	0.53	2078	5.61	2.97	0.53	2195	5.23	2.77	0.53	2274
26	24	6.33	2.59	0.41	2156	5.94	2.44	0.41	2254	5.61	2.30	0.41	2352
26	26	6.66	1.93	0.29	2234	6.27	1.82	0.29	2332	5.89	1.71	0.29	2430
27	18	5.39	4.37	0.81	1921	4.95	4.01	0.81	2038	4.57	3.70	0.81	2117
27	20	5.67	3.91	0.69	1999	5.28	3.64	0.69	2097	4.90	3.38	0.69	2215
27	22	6.00	3.42	0.57	2078	5.61	3.20	0.57	2195	5.23	2.98	0.57	2274
27	24	6.33	2.85	0.45	2156	5.94	2.67	0.45	2254	5.61	2.52	0.45	2352
27	26	6.66	2.20	0.33	2234	6.27	2.07	0.33	2332	5.89	1.94	0.33	2430
28	18	5.39	4.58	0.85	1921	4.95	4.21	0.85	2038	4.57	3.88	0.85	2117
28	20	5.67	4.14	0.73	1999	5.28	3.85	0.73	2097	4.90	3.57	0.73	2215
28	22	6.00	3.66	0.61	2078	5.61	3.42	0.61	2195	5.23	3.19	0.61	2274
28	24	6.33	3.10	0.49	2156	5.94	2.91	0.49	2254	5.61	2.75	0.49	2352
28	26	6.66	2.46	0.37	2234	6.27	2.32	0.37	2332	5.89	2.18	0.37	2430
29	18	5.39	4.80	0.89	1921	4.95	4.41	0.89	2038	4.57	4.06	0.89	2117
29	20	5.67	4.36	0.77	1999	5.28	4.07	0.77	2097	4.90	3.77	0.77	2215
29	22	6.00	3.90	0.65	2078	5.61	3.65	0.65	2195	5.23	3.40	0.65	2274
29	24	6.33	3.35	0.53	2156	5.94	3.15	0.53	2254	5.61	2.97	0.53	2352
29	26	6.66	2.73	0.41	2234	6.27	2.57	0.41	2332	5.89	2.41	0.41	2430
30	18	5.39	5.01	0.93	1921	4.95	4.60	0.93	2038	4.57	4.25	0.93	2117
30	20	5.67	4.59	0.81	1999	5.28	4.28	0.81	2097	4.90	3.96	0.81	2215
30	22	6.00	4.14	0.69	2078	5.61	3.87	0.69	2195	5.23	3.61	0.69	2274
30	24	6.33	3.61	0.57	2156	5.94	3.39	0.57	2254	5.61	3.20	0.57	2352
30	26	6.66	2.99	0.45	2234	6.27	2.82	0.45	2332	5.89	2.65	0.45	2430
31	18	5.39	5.23	0.97	1921	4.95	4.80	0.97	2038	4.57	4.43	0.97	2117
31	20	5.67	4.82	0.85	1999	5.28	4.49	0.85	2097	4.90	4.16	0.85	2215
31	22	6.00	4.38	0.73	2078	5.61	4.10	0.73	2195	5.23	3.81	0.73	2274
31	24	6.33	3.86	0.61	2156	5.94	3.62	0.61	2254	5.61	3.42	0.61	2352
31	26	6.66	3.26	0.49	2234	6.27	3.07	0.49	2332	5.89	2.88	0.49	2430
32	18	5.39	5.39	1.00	1921	4.95	4.95	1.00	2038	4.57	4.57	1.00	2117
32	20	5.67	5.04	0.89	1999	5.28	4.70	0.89	2097	4.90	4.36	0.89	2215
32	22	6.00	4.62	0.77	2078	5.61	4.32	0.77	2195	5.23	4.02	0.77	2274
32	24	6.33	4.11	0.65	2156	5.94	3.86	0.65	2254	5.61	3.65	0.65	2352
32	26	6.66	3.53	0.53	2234	6.27	3.32	0.53	2332	5.89	3.12	0.53	2430

**NOTE** Q : Total capacity (kW) SHF : Sensible heat factor DB : Dry-bulb temperature  
 SHC : Sensible heat capacity (kW) INPUT : Total power input (W) WB : Wet-bulb temperature

**PERFORMANCE DATA**

**COOLING operation at Rated frequency**

**SEZ-KA71VA/SUZ-KA71VA**

CAPACITY : 7.1(kW) INPUT : 2460(W) SHF : 0.74

		OUTDOOR D.B.(°C)															
INDOOR D.B.(°C)	INDOOR W.B.(°C)	21				25				27				30			
		Q	SHC	SHF	INPUT	Q	SHC	SHF	INPUT	Q	SHC	SHF	INPUT	Q	SHC	SHF	INPUT
21	18	8.34	4.67	0.56	1968	7.99	4.47	0.56	2066	7.67	4.29	0.56	2165	7.38	4.14	0.56	2263
21	20	8.70	3.83	0.44	2066	8.34	3.67	0.44	2189	8.09	3.56	0.44	2239	7.81	3.44	0.44	2337
22	18	8.34	5.01	0.60	1968	7.99	4.79	0.60	2066	7.67	4.60	0.60	2165	7.38	4.43	0.60	2263
22	20	8.70	4.17	0.48	2066	8.34	4.00	0.48	2189	8.09	3.89	0.48	2239	7.81	3.75	0.48	2337
22	22	9.05	3.26	0.36	2140	8.73	3.14	0.36	2276	8.52	3.07	0.36	2337	8.17	2.94	0.36	2435
23	18	8.34	5.34	0.64	1968	7.99	5.11	0.64	2066	7.67	4.91	0.64	2165	7.38	4.73	0.64	2263
23	20	8.70	4.52	0.52	2066	8.34	4.34	0.52	2189	8.09	4.21	0.52	2239	7.81	4.06	0.52	2337
23	22	9.05	3.62	0.40	2140	8.73	3.49	0.40	2276	8.52	3.41	0.40	2337	8.17	3.27	0.40	2435
24	18	8.34	5.67	0.68	1968	7.99	5.43	0.68	2066	7.67	5.21	0.68	2165	7.38	5.02	0.68	2263
24	20	8.70	4.87	0.56	2066	8.34	4.67	0.56	2189	8.09	4.53	0.56	2239	7.81	4.37	0.56	2337
24	22	9.05	3.98	0.44	2140	8.73	3.84	0.44	2276	8.52	3.75	0.44	2337	8.17	3.59	0.44	2435
24	24	9.51	3.04	0.32	2239	9.16	2.93	0.32	2362	8.95	2.86	0.32	2435	8.66	2.77	0.32	2558
25	20	8.70	5.22	0.60	2066	8.34	5.01	0.60	2189	8.09	4.86	0.60	2239	7.81	4.69	0.60	2337
25	22	9.05	4.35	0.48	2140	8.73	4.19	0.48	2276	8.52	4.09	0.48	2337	8.17	3.92	0.48	2435
25	24	9.51	3.43	0.36	2239	9.16	3.30	0.36	2362	8.95	3.22	0.36	2435	8.66	3.12	0.36	2558
26	18	8.34	6.34	0.76	1968	7.99	6.07	0.76	2066	7.67	5.83	0.76	2165	7.38	5.61	0.76	2263
26	20	8.70	5.57	0.64	2066	8.34	5.34	0.64	2189	8.09	5.18	0.64	2239	7.81	5.00	0.64	2337
26	22	9.05	4.71	0.52	2140	8.73	4.54	0.52	2276	8.52	4.43	0.52	2337	8.17	4.25	0.52	2435
26	24	9.51	3.81	0.40	2239	9.16	3.66	0.40	2362	8.95	3.58	0.40	2435	8.66	3.46	0.40	2558
26	26	9.80	2.74	0.28	2362	9.51	2.66	0.28	2485	9.37	2.62	0.28	2558	9.09	2.54	0.28	2632
27	18	8.34	6.67	0.80	1968	7.99	6.39	0.80	2066	7.67	6.13	0.80	2165	7.38	5.91	0.80	2263
27	20	8.70	5.91	0.68	2066	8.34	5.67	0.68	2189	8.09	5.50	0.68	2239	7.81	5.31	0.68	2337
27	22	9.05	5.07	0.56	2140	8.73	4.89	0.56	2276	8.52	4.77	0.56	2337	8.17	4.57	0.56	2435
27	24	9.51	4.19	0.44	2239	9.16	4.03	0.44	2362	8.95	3.94	0.44	2435	8.66	3.81	0.44	2558
27	26	9.80	3.14	0.32	2362	9.51	3.04	0.32	2485	9.37	3.00	0.32	2558	9.09	2.91	0.32	2632
28	18	8.34	7.01	0.84	1968	7.99	6.71	0.84	2066	7.67	6.44	0.84	2165	7.38	6.20	0.84	2263
28	20	8.70	6.26	0.72	2066	8.34	6.01	0.72	2189	8.09	5.83	0.72	2239	7.81	5.62	0.72	2337
28	22	9.05	5.43	0.60	2140	8.73	5.24	0.60	2276	8.52	5.11	0.60	2337	8.17	4.90	0.60	2435
28	24	9.51	4.57	0.48	2239	9.16	4.40	0.48	2362	8.95	4.29	0.48	2435	8.66	4.16	0.48	2558
28	26	9.80	3.53	0.36	2362	9.51	3.43	0.36	2485	9.37	3.37	0.36	2558	9.09	3.27	0.36	2632
29	18	8.34	7.34	0.88	1968	7.99	7.03	0.88	2066	7.67	6.75	0.88	2165	7.38	6.50	0.88	2263
29	20	8.70	6.61	0.76	2066	8.34	6.34	0.76	2189	8.09	6.15	0.76	2239	7.81	5.94	0.76	2337
29	22	9.05	5.79	0.64	2140	8.73	5.59	0.64	2276	8.52	5.45	0.64	2337	8.17	5.23	0.64	2435
29	24	9.51	4.95	0.52	2239	9.16	4.76	0.52	2362	8.95	4.65	0.52	2435	8.66	4.50	0.52	2558
29	26	9.80	3.92	0.40	2362	9.51	3.81	0.40	2485	9.37	3.75	0.40	2558	9.09	3.64	0.40	2632
30	18	8.34	7.68	0.92	1968	7.99	7.35	0.92	2066	7.67	7.05	0.92	2165	7.38	6.79	0.92	2263
30	20	8.70	6.96	0.80	2066	8.34	6.67	0.80	2189	8.09	6.48	0.80	2239	7.81	6.25	0.80	2337
30	22	9.05	6.16	0.68	2140	8.73	5.94	0.68	2276	8.52	5.79	0.68	2337	8.17	5.55	0.68	2435
30	24	9.51	5.33	0.56	2239	9.16	5.13	0.56	2362	8.95	5.01	0.56	2435	8.66	4.85	0.56	2558
30	26	9.80	4.31	0.44	2362	9.51	4.19	0.44	2485	9.37	4.12	0.44	2558	9.09	4.00	0.44	2632
31	18	8.34	8.01	0.96	1968	7.99	7.67	0.96	2066	7.67	7.36	0.96	2165	7.38	7.09	0.96	2263
31	20	8.70	7.31	0.84	2066	8.34	7.01	0.84	2189	8.09	6.80	0.84	2239	7.81	6.56	0.84	2337
31	22	9.05	6.52	0.72	2140	8.73	6.29	0.72	2276	8.52	6.13	0.72	2337	8.17	5.88	0.72	2435
31	24	9.51	5.71	0.60	2239	9.16	5.50	0.60	2362	8.95	5.37	0.60	2435	8.66	5.20	0.60	2558
31	26	9.80	4.70	0.48	2362	9.51	4.57	0.48	2485	9.37	4.50	0.48	2558	9.09	4.36	0.48	2632
32	18	8.34	8.34	1.00	1968	7.99	7.99	1.00	2066	7.67	7.67	1.00	2165	7.38	7.38	1.00	2263
32	20	8.70	7.65	0.88	2066	8.34	7.34	0.88	2189	8.09	7.12	0.88	2239	7.81	6.87	0.88	2337
32	22	9.05	6.88	0.76	2140	8.73	6.64	0.76	2276	8.52	6.48	0.76	2337	8.17	6.21	0.76	2435
32	24	9.51	6.09	0.64	2239	9.16	5.86	0.64	2362	8.95	5.73	0.64	2435	8.66	5.54	0.64	2558
32	26	9.80	5.09	0.52	2362	9.51	4.95	0.52	2485	9.37	4.87	0.52	2558	9.09	4.73	0.52	2632

**NOTE** Q : Total capacity (kW) SHF : Sensible heat factor DB : Dry-bulb temperature  
 SHC : Sensible heat capacity (kW) INPUT : Total power input (W) WB : Wet-bulb temperature

**PERFORMANCE DATA**

**COOLING operation at Rated frequency**

**SEZ-KA71VA/SUZ-KA71VA**

CAPACITY : 7.1(kW) INPUT : 2460(W) SHF : 0.74

INDOOR D.B.(°C)	INDOOR W.B.(°C)	OUTDOOR D.B.(°C)											
		35				40				46			
		Q	SHC	SHF	INPUT	Q	SHC	SHF	INPUT	Q	SHC	SHF	INPUT
21	18	6.96	3.90	0.56	2411	6.39	3.58	0.56	2558	5.89	3.30	0.56	2657
21	20	7.31	3.22	0.44	2509	6.82	3.00	0.44	2632	6.32	2.78	0.44	2780
22	18	6.96	4.17	0.60	2411	6.39	3.83	0.60	2558	5.89	3.54	0.60	2657
22	20	7.31	3.51	0.48	2509	6.82	3.27	0.48	2632	6.32	3.03	0.48	2780
22	22	7.74	2.79	0.36	2608	7.24	2.61	0.36	2755	6.75	2.43	0.36	2854
23	18	6.96	4.45	0.64	2411	6.39	4.09	0.64	2558	5.89	3.77	0.64	2657
23	20	7.31	3.80	0.52	2509	6.82	3.54	0.52	2632	6.32	3.29	0.52	2780
23	22	7.74	3.10	0.40	2608	7.24	2.90	0.40	2755	6.75	2.70	0.40	2854
24	18	6.96	4.73	0.68	2411	6.39	4.35	0.68	2558	5.89	4.01	0.68	2657
24	20	7.31	4.10	0.56	2509	6.82	3.82	0.56	2632	6.32	3.54	0.56	2780
24	22	7.74	3.41	0.44	2608	7.24	3.19	0.44	2755	6.75	2.97	0.44	2854
24	24	8.17	2.61	0.32	2706	7.67	2.45	0.32	2829	7.24	2.32	0.32	2952
25	20	7.31	4.39	0.60	2509	6.82	4.09	0.60	2632	6.32	3.79	0.60	2780
25	22	7.74	3.71	0.48	2608	7.24	3.48	0.48	2755	6.75	3.24	0.48	2854
25	24	8.17	2.94	0.36	2706	7.67	2.76	0.36	2829	7.24	2.61	0.36	2952
26	18	6.96	5.29	0.76	2411	6.39	4.86	0.76	2558	5.89	4.48	0.76	2657
26	20	7.31	4.68	0.64	2509	6.82	4.36	0.64	2632	6.32	4.04	0.64	2780
26	22	7.74	4.02	0.52	2608	7.24	3.77	0.52	2755	6.75	3.51	0.52	2854
26	24	8.17	3.27	0.40	2706	7.67	3.07	0.40	2829	7.24	2.90	0.40	2952
26	26	8.59	2.41	0.28	2804	8.09	2.27	0.28	2927	7.60	2.13	0.28	3050
27	18	6.96	5.57	0.80	2411	6.39	5.11	0.80	2558	5.89	4.71	0.80	2657
27	20	7.31	4.97	0.68	2509	6.82	4.63	0.68	2632	6.32	4.30	0.68	2780
27	22	7.74	4.33	0.56	2608	7.24	4.06	0.56	2755	6.75	3.78	0.56	2854
27	24	8.17	3.59	0.44	2706	7.67	3.37	0.44	2829	7.24	3.19	0.44	2952
27	26	8.59	2.75	0.32	2804	8.09	2.59	0.32	2927	7.60	2.43	0.32	3050
28	18	6.96	5.84	0.84	2411	6.39	5.37	0.84	2558	5.89	4.95	0.84	2657
28	20	7.31	5.27	0.72	2509	6.82	4.91	0.72	2632	6.32	4.55	0.72	2780
28	22	7.74	4.64	0.60	2608	7.24	4.35	0.60	2755	6.75	4.05	0.60	2854
28	24	8.17	3.92	0.48	2706	7.67	3.68	0.48	2829	7.24	3.48	0.48	2952
28	26	8.59	3.09	0.36	2804	8.09	2.91	0.36	2927	7.60	2.73	0.36	3050
29	18	6.96	6.12	0.88	2411	6.39	5.62	0.88	2558	5.89	5.19	0.88	2657
29	20	7.31	5.56	0.76	2509	6.82	5.18	0.76	2632	6.32	4.80	0.76	2780
29	22	7.74	4.95	0.64	2608	7.24	4.63	0.64	2755	6.75	4.32	0.64	2854
29	24	8.17	4.25	0.52	2706	7.67	3.99	0.52	2829	7.24	3.77	0.52	2952
29	26	8.59	3.44	0.40	2804	8.09	3.24	0.40	2927	7.60	3.04	0.40	3050
30	18	6.96	6.40	0.92	2411	6.39	5.88	0.92	2558	5.89	5.42	0.92	2657
30	20	7.31	5.85	0.80	2509	6.82	5.45	0.80	2632	6.32	5.06	0.80	2780
30	22	7.74	5.26	0.68	2608	7.24	4.92	0.68	2755	6.75	4.59	0.68	2854
30	24	8.17	4.57	0.56	2706	7.67	4.29	0.56	2829	7.24	4.06	0.56	2952
30	26	8.59	3.78	0.44	2804	8.09	3.56	0.44	2927	7.60	3.34	0.44	3050
31	18	6.96	6.68	0.96	2411	6.39	6.13	0.96	2558	5.89	5.66	0.96	2657
31	20	7.31	6.14	0.84	2509	6.82	5.73	0.84	2632	6.32	5.31	0.84	2780
31	22	7.74	5.57	0.72	2608	7.24	5.21	0.72	2755	6.75	4.86	0.72	2854
31	24	8.17	4.90	0.60	2706	7.67	4.60	0.60	2829	7.24	4.35	0.60	2952
31	26	8.59	4.12	0.48	2804	8.09	3.89	0.48	2927	7.60	3.65	0.48	3050
32	18	6.96	6.96	1.00	2411	6.39	6.39	1.00	2558	5.89	5.89	1.00	2657
32	20	7.31	6.44	0.88	2509	6.82	6.00	0.88	2632	6.32	5.56	0.88	2780
32	22	7.74	5.88	0.76	2608	7.24	5.50	0.76	2755	6.75	5.13	0.76	2854
32	24	8.17	5.23	0.64	2706	7.67	4.91	0.64	2829	7.24	4.63	0.64	2952
32	26	8.59	4.47	0.52	2804	8.09	4.21	0.52	2927	7.60	3.95	0.52	3050

**NOTE** Q : Total capacity (kW) SHF : Sensible heat factor DB : Dry-bulb temperature  
 SHC : Sensible heat capacity (kW) INPUT : Total power input (W) WB : Wet-bulb temperature

**PERFORMANCE DATA**

**HEATING operation**

**SLZ-KA25VA(L)/SUZ-KA25VA(H) at Rated frequency**

CAPACITY : 3.0(kW) INPUT : 830(W)

INDOOR D.B.(°C)	OUTDOOR W.B.(°C)															
	-15		-10		-5		0		5		10		15		20	
	Q	INPUT	Q	INPUT	Q	INPUT	Q	INPUT	Q	INPUT	Q	INPUT	Q	INPUT	Q	INPUT
15	1.50	432	1.89	540	2.28	647	2.67	730	3.06	789	3.45	838	3.81	863	4.20	880
21	1.41	460	1.80	581	2.16	689	2.55	764	2.91	822	3.30	863	3.66	888	4.04	921
26	1.23	498	1.62	623	2.01	730	2.37	805	2.76	863	3.15	905	3.51	930	3.90	955

**SLZ-KA35VA(L)/SUZ-KA35VA(H) at Rated frequency**

CAPACITY : 4.0(kW) INPUT : 1100(W)

INDOOR D.B.(°C)	OUTDOOR W.B.(°C)															
	-15		-10		-5		0		5		10		15		20	
	Q	INPUT	Q	INPUT	Q	INPUT	Q	INPUT	Q	INPUT	Q	INPUT	Q	INPUT	Q	INPUT
15	2.00	572	2.52	715	3.04	858	3.56	968	4.08	1045	4.60	1111	5.08	1144	5.60	1166
21	1.88	609	2.40	770	2.88	913	3.40	1012	3.88	1089	4.40	1144	4.88	1177	5.38	1221
26	1.64	660	2.16	825	2.68	968	3.16	1067	3.68	1144	4.20	1199	4.68	1232	5.20	1265

**SLZ-KA50VA(L)/SUZ-KA50VA at Rated frequency**

CAPACITY : 5.0(kW) INPUT : 1550(W)

INDOOR D.B.(°C)	OUTDOOR W.B.(°C)													
	-10		-5		0		5		10		15		20	
	Q	INPUT	Q	INPUT	Q	INPUT	Q	INPUT	Q	INPUT	Q	INPUT	Q	INPUT
15	3.15	1008	3.80	1209	4.45	1364	5.10	1473	5.75	1566	6.35	1612	7.00	1643
21	3.00	1085	3.60	1287	4.25	1426	4.85	1535	5.50	1612	6.10	1659	6.73	1721
26	2.70	1163	3.35	1364	3.95	1504	4.60	1612	5.25	1690	5.85	1739	6.50	1783

**SEZ-KC25VA/SUZ-KA25VA(H) at Rated frequency**

CAPACITY : 3.0(kW) INPUT : 830(W)

INDOOR D.B.(°C)	OUTDOOR W.B.(°C)															
	-15		-10		-5		0		5		10		15		20	
	Q	INPUT	Q	INPUT	Q	INPUT	Q	INPUT	Q	INPUT	Q	INPUT	Q	INPUT	Q	INPUT
15	1.50	432	1.89	540	2.28	647	2.67	730	3.06	789	3.45	838	3.81	863	4.20	880
21	1.41	460	1.80	581	2.16	689	2.55	764	2.91	822	3.30	863	3.66	888	4.04	921
26	1.23	498	1.62	623	2.01	730	2.37	805	2.76	863	3.15	905	3.51	930	3.90	955

**SEZ-KA35VA/SUZ-KA35VA(H) at Rated frequency**

CAPACITY : 4.0(kW) INPUT : 1100(W)

INDOOR D.B.(°C)	OUTDOOR W.B.(°C)															
	-15		-10		-5		0		5		10		15		20	
	Q	INPUT	Q	INPUT	Q	INPUT	Q	INPUT	Q	INPUT	Q	INPUT	Q	INPUT	Q	INPUT
15	2.00	572	2.52	715	3.04	858	3.56	968	4.08	1045	4.60	1111	5.08	1144	5.60	1166
21	1.88	609	2.40	770	2.88	913	3.40	1012	3.88	1089	4.40	1144	4.88	1177	5.38	1221
26	1.64	660	2.16	825	2.68	968	3.16	1067	3.68	1144	4.20	1199	4.68	1232	5.20	1265

**SEZ-KA50VA/SUZ-KA50VA at Rated frequency**

CAPACITY : 5.9(kW) INPUT : 1840(W)

INDOOR D.B.(°C)	OUTDOOR W.B.(°C)													
	-10		-5		0		5		10		15		20	
	Q	INPUT	Q	INPUT	Q	INPUT	Q	INPUT	Q	INPUT	Q	INPUT	Q	INPUT
15	3.72	1196	4.48	1435	5.25	1619	6.02	1748	6.79	1858	7.49	1914	8.26	1950
21	3.54	1288	4.25	1527	5.02	1693	5.72	1822	6.49	1914	7.20	1969	7.94	2042
26	3.19	1380	3.95	1619	4.66	1785	5.43	1914	6.20	2006	6.90	2061	7.67	2116

**SEZ-KA60VA/SUZ-KA60VA at Rated frequency**

CAPACITY : 6.9(kW) INPUT : 2450(W)

INDOOR D.B.(°C)	OUTDOOR W.B.(°C)													
	-10		-5		0		5		10		15		20	
	Q	INPUT	Q	INPUT	Q	INPUT	Q	INPUT	Q	INPUT	Q	INPUT	Q	INPUT
15	4.35	1593	5.24	1911	6.14	2156	7.04	2328	7.94	2475	8.76	2548	9.66	2597
21	4.14	1715	4.97	2034	5.87	2254	6.69	2426	7.59	2548	8.42	2622	9.28	2720
26	3.73	1838	4.62	2156	5.45	2377	6.35	2548	7.25	2671	8.07	2744	8.97	2818

**SEZ-KA71VA/SUZ-KA71VA at Rated frequency**

CAPACITY : 8.1(kW) INPUT : 2360(W)

INDOOR D.B.(°C)	OUTDOOR W.B.(°C)													
	-10		-5		0		5		10		15		20	
	Q	INPUT	Q	INPUT	Q	INPUT	Q	INPUT	Q	INPUT	Q	INPUT	Q	INPUT
15	5.10	1534	6.16	1841	7.21	2077	8.26	2242	9.32	2384	10.29	2454	11.34	2502
21	4.86	1652	5.83	1959	6.89	2171	7.86	2336	8.91	2454	9.88	2525	10.89	2620
26	4.37	1770	5.43	2077	6.40	2289	7.45	2454	8.51	2572	9.48	2643	10.53	2714



# 10

# ACTUATOR CONTROL

SUZ-KA25VA(H) SUZ-KA35VA(H) SUZ-KA50VA SUZ-KA60VA SUZ-KA71VA

## 10-1. Outdoor fan motor control

The fan motor turns ON/OFF, interlocking with the compressor.

[ON] The fan motor turns ON 5 seconds before the compressor starts up.

[OFF] The fan motor turns OFF 15 seconds after the compressor has stopped running.

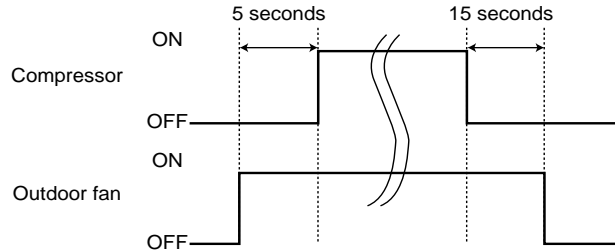

## 10-2. R.V. coil control

Heating ..... ON  
 Cooling ..... OFF  
 Dry ..... OFF

**NOTE:** The 4-way valve reverses for 5 seconds right before start-up of the compressor.

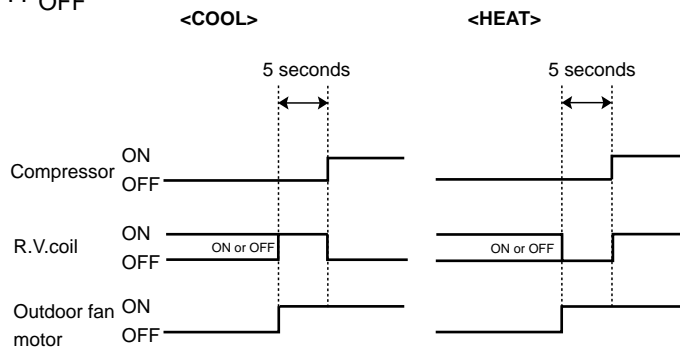

## 10-3. Relation between main sensor and actuator

SUZ-KA25VA(H).TH SUZ-KA35VA(H).TH

Sensor	Purpose	Actuator					
		Compressor	LEV	Outdoor fan motor	RV-coil	Indoor fan motor	Defrost heater
Discharge temperature thermistor	Protection	○	○				
Indoor pipe temperature thermistor	Cooling: Coil frost prevention	○					
	Heating: High pressure protection	○	○				
Defrost thermistor	Cooling: High pressure protection	○	○				
	Heating: Defrosting	○	○	○	○	○	
Fin temperature thermistor	Protection	○		○			
Ambient temperature thermistor	Cooling: Low ambient temperature operation	○	○	○			
	Heating: Defrosting (Heater)						○

SUZ-KA25VA(H)R1.TH SUZ-KA35VA(H)R1.TH

Sensor	Purpose	Actuator					
		Compressor	LEV	Outdoor fan motor	R.V.coil	Indoor fan motor	Defrost heater
Discharge temperature thermistor	Protection	○	○				
Indoor coil temperature thermistor	Cooling: Coil frost prevention	○					
	Heating: High pressure protection	○	○				
Defrost thermistor	Heating: Defrosting	○	○	○	○	○	
Fin temperature thermistor	Protection	○		○			
Ambient temperature thermistor	Cooling: Low ambient temperature operation	○	○	○			
	Heating: Defrosting (Heater)						○
Outdoor heat exchanger temperature thermistor	Cooling: Low ambient temperature operation	○	○	○			
	Cooling: High pressure protection	○	○	○			

Sensor	Purpose	Actuator			
		Compressor	LEV	Outdoor fan motor	4-way valve
Discharge temperature thermistor	Protection	○	○		
Indoor pipe temperature thermistor	Cooling: Coil frost prevention	○			
	Heating: High pressure protection	○	○		
Defrost thermistor	Heating: Defrosting	○	○	○	○
Fin temperature thermistor	Protection	○		○	
Ambient temperature thermistor	Protection	○	○	○	
Outdoor heat exchanger temperature	Cooling: High pressure protection	○	○	○	

# 11 SERVICE FUNCTIONS

## SUZ-KA25VA(H)    SUZ-KA35VA(H)

### CHANGE IN DEFROST SETTING

<JS> When the JS wire of the outdoor Inverter P.C. board is cut/ soldered, the defrost finish temperature is changed.

(Refer to 12-6-1 SUZ-KA25/35VA(H).TH)  
 (Refer to 12-6-3 SUZ-KA25/35VA(H)R1.TH)

Jumper wire		Defrost finish temperature				
		SUZ-KA25VA	SUZ-KA25VAH	SUZ-KA35VA	SUZ-KA35VAH	
JS	Soldered (Initial setting)	5 °C	8 °C	10 °C	13 °C	10 °C
	None (cut)	8 °C	15 °C	13 °C	15 °C	13 °C
Serial No.		—	~9XP00121	—	~67P00330	68P00331~

Jumper wire		Defrost finish temperature				
		SUZ-KA25VA	SUZ-KA25VAH	SUZ-KA35VA	SUZ-KA35VAH	
JS	Soldered	/	8 °C	/	/	/
	None (Initial setting)		15 °C			
Serial No.						

# 12 TROUBLESHOOTING

## SUZ-KA25VA(H)    SUZ-KA35VA(H)    SUZ-KA50VA    SUZ-KA60VA    SUZ-KA71VA

### 12-1. Cautions on troubleshooting

#### 1. Before troubleshooting, check the following:

- 1) Check the power supply voltage.
- 2) Check the indoor/outdoor connecting wire for miswiring.

#### 2. Take care the following during servicing.

- 1) Before servicing the air conditioner, be sure to turn OFF the main unit first with the remote controller, and turn off the breaker.
- 2) Be sure to turn OFF the power supply before removing the front panel, the cabinet, the top panel, and the electronic control P.C. board.
- 3) When removing the electrical parts, be careful of the residual voltage of smoothing capacitor.
- 4) When removing the electronic control P.C. board, hold the edge of the board with care NOT to apply stress on the components.
- 5) When connecting or disconnecting the connectors, hold the housing of the connector. DO NOT pull the lead wires.

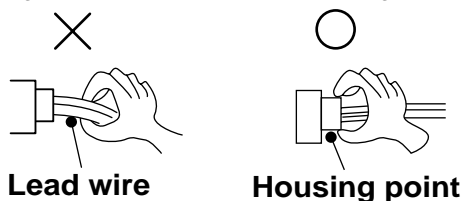

#### 3. Troubleshooting procedure

- 1) First, check if the OPERATION INDICATOR lamp is blinking on and off to indicate an abnormality. To make sure, check how many times the abnormality indication is blinking on and off before starting service work.
- 2) Before servicing check that the connector and terminal are connected properly.
- 3) If the electronic control P.C. board is supposed to be defective, check the copper foil pattern for disconnection and the components for bursting and discoloration.
- 4) When troubleshooting, refer to 12-2. and 12-3.

## 12-2. Failure mode recall function

As this air conditioner has a function to memorize all the failures that had happened, the latest failure detail can be recalled by following the procedures below.

Use this function when the check code is not displayed with wired remote controller or the remote controller at use is wireless type.

### 12-2-1. Flow chart of the indoor/outdoor unit failure mode recall function

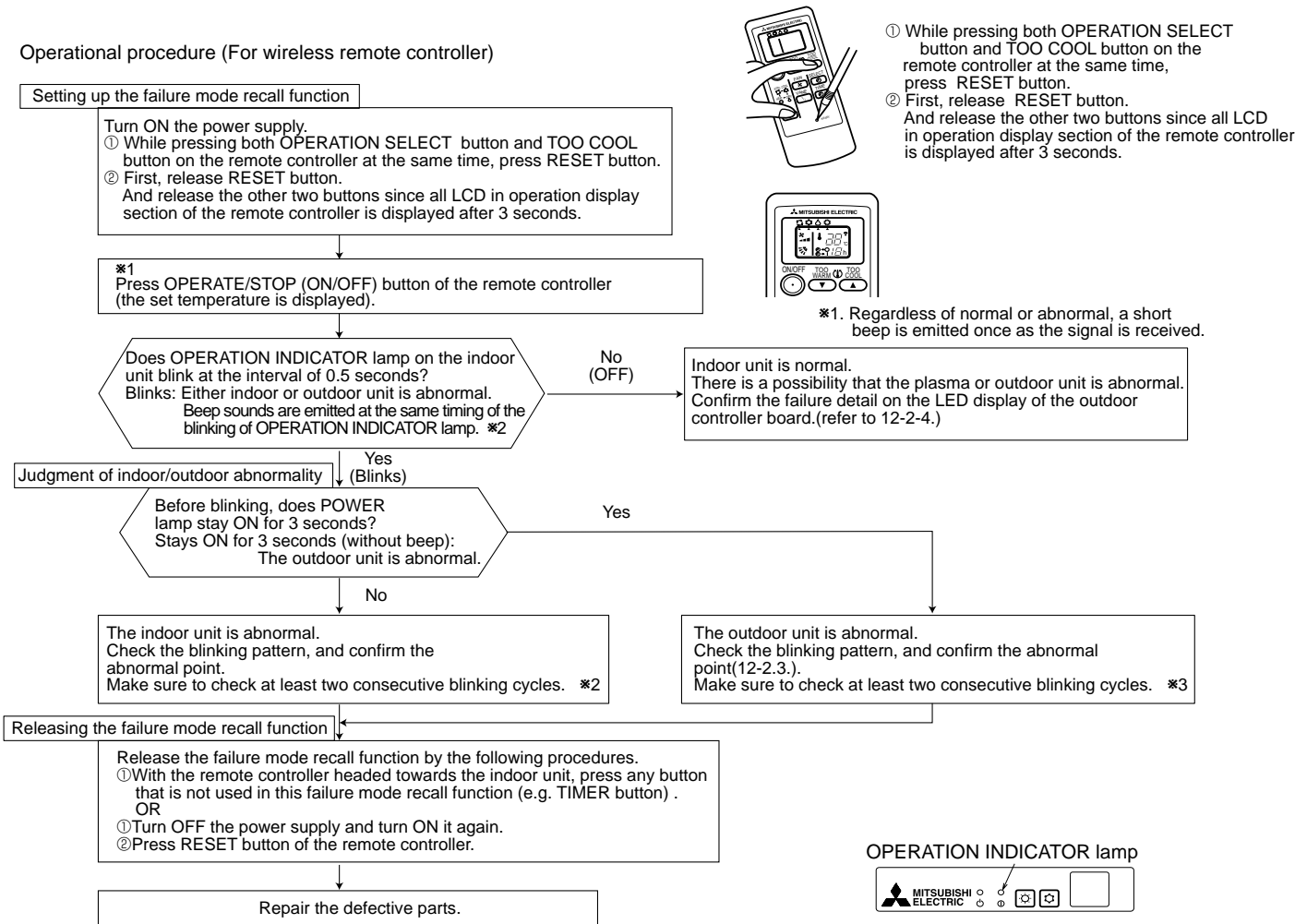

Note1. Make sure to release the failure mode recall function once it is set up, otherwise the unit cannot operate properly.  
 2. If the abnormal condition is not deleted from the memory, the last abnormal condition is kept memorized.

#### ※2. Blinking pattern when the indoor unit is abnormal:[Output pattern A]

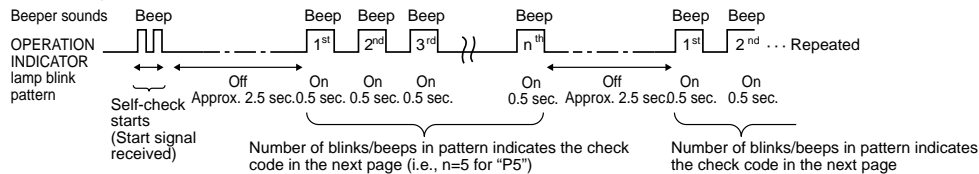

#### ※3. Blinking pattern when the outdoor unit is abnormal:[Output pattern B]

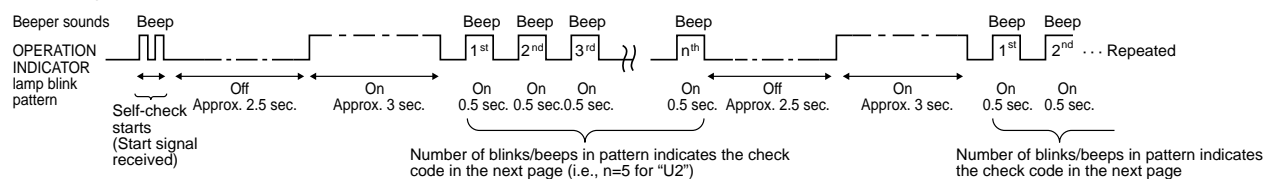

## 12-2-2. Wired remote controller

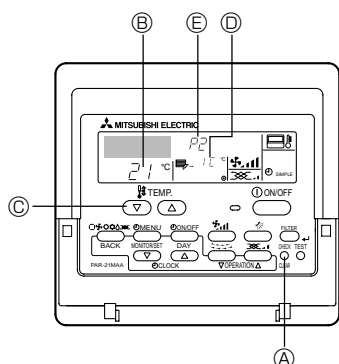

- Ⓐ CHECK button
- Ⓑ Refrigerant address
- Ⓒ TEMP. button
- Ⓓ IC: Indoor unit
- Ⓔ OC: Outdoor unit
- Ⓔ Check code

- ① Turn on the power.
- ② Press the [CHECK] button twice.
- ③ Set refrigerant address with [TEMP] button if system control is used.
- ④ Press the [ON/OFF] button to stop the self-check.

## 12-2-3. Failure mode table (Wireless remote controller/Wired remote controller)

[Output pattern A] Errors detected by indoor unit

Wired remote controller	Wireless remote controller	Symptom	Remark
Check code	Beeper sounds/OPERATION INDICATOR lamp blinks (Number of times)		
P1	1	Intake sensor error	
P2	2	Pipe (TH2) sensor error	
P9		Pipe (TH5) sensor error	
E6,E7	3	Indoor/outdoor unit communication error	
P4	4	Drain sensor error/Float switch connector open	
P5	5	Drain pump error	
P6	6	Freezing/Overheating protection operation	
EE	7	Communication error between indoor and outdoor units	
P8	8	Pipe temperature error	
E4, E5	9	Remote controller signal receiving error	
—	10	—	
—	11	—	
Fb	12	Indoor unit control system error (memory error, etc.)	
E0, E3	—	Remote controller transmission error	
E1, E2	—	Remote controller control board error	

[Output pattern B] Errors detected by unit other than indoor unit (outdoor unit, etc.)

Wired remote controller	Wireless remote controller	Symptom	Remark
Check code	Beeper sounds/OPERATION INDICATOR lamp blinks (Number of times)		
E9	1	Indoor/outdoor unit communication error (Transmitting error) (Outdoor unit)	For details, check the LED display of the outdoor controller board.
UP	2	Compressor overcurrent interruption	
U3,U4	3	Open/short of outdoor unit thermistors	
UF	4	Compressor overcurrent interruption (When compressor locked)	
U2	5	Abnormal high discharging temperature/insufficient refrigerant	
U1,Ud	6	Abnormal high pressure (63H worked)/Overheating protection operation	
U5	7	Abnormal temperature of heat sink	
U8	8	Outdoor unit fan protection stop	
U6	9	Compressor overcurrent interruption/Abnormal of power module	
U7	10	Abnormality of super heat due to low discharge temperature	
U9,UH	11	Abnormality such as overvoltage or voltage shortage and abnormal synchronous signal to main circuit/Current sensor error	
—	12	—	
—	13	—	
Others	14	Other errors	

- If the beeper does not sound again after the initial two beeps to confirm the self-check start signal was received and the OPERATION INDICATOR lamp does not come on, there are no error records.
- If the beeper sounds three times continuously "beep, beep, beep (0.4 + 0.4 + 0.4 sec.)" after the initial two beeps to confirm the self-check start signal was received, the specified refrigerant address is incorrect.
- On wireless remote controller  
The continuous buzzer sounds from receiving section of indoor unit.  
Blink of operation lamp
- On wired remote controller  
Check code displayed in the LCD.

## 12-2-4. Outdoor unit failure mode table SUZ-KA25VA(H) SUZ-KA35VA(H) (Except for SUZ-KA25/35VA(H)R1.TH)

LED indication (Outdoor unit)	Abnormal point (Failure mode)	Details of abnormal	Detection method	Check point
1-time flash every 2.5 seconds	Outdoor thermistors	Discharge temperature	When thermistors short or open during compressor running.	<ul style="list-style-type: none"> <li>•Check the outdoor thermistors</li> <li>※Defective outdoor thermistors can be identified by checking the blinking pattern of LED.</li> </ul>
2-time flash 2.5 seconds OFF		Defrost thermistor		
3-time flash 2.5 seconds OFF		Ambient temperature thermistor		
4-time flash 2.5 seconds OFF		Fin temperature thermistor		
5-time flash 2.5 seconds OFF	Outdoor control system	P.C. board temperature thermistor		
5-time flash 2.5 seconds OFF	Outdoor control system	Nonvolatile memory data	When nonvolatile memory data cannot be read properly, unit stops.	•Replace the inverter P.C. board.
7-time flash 2.5 seconds OFF	Fin temperature/P.C. board temperature overheat	Fin temperature/P.C. board temperature overheat protection	When fin temperature exceeds 83°C (SUZ-KA25VA(H))/82°C (SUZ-KA35VA(H)), or P.C. board temperature exceeds 85°C (SUZ-KA25VA(H))/81°C (SUZ-KA35VA(H)).	<ul style="list-style-type: none"> <li>•Check around outdoor unit.</li> <li>•Check outdoor unit air passage.</li> <li>•Check the outdoor fan motor.</li> </ul>
8-time flash 2.5 seconds OFF	Converter control system	DC voltage	When DC voltage of inverter cannot be detected normally.	•Check the inverter/compressor.
9-time flash 2.5 seconds OFF		Compressor each phase current	When compressor each phase current cannot be detected normally.	
10-time flash 2.5 seconds OFF	Overcurrent protection	Compressor open-phase protection	When 14A (SUZ-KA25VA(H))/24A (SUZ-KA35VA(H)) current flow into intelligent power module (IPM). When the open-phase protection of compressor is detected. When the interphase short out occurs in the output of the intelligent power module (IPM). When the compressor winding shorts out.	<ul style="list-style-type: none"> <li>•Reconnect compressor connector.</li> <li>•Check the inverter/compressor.</li> </ul>
11-time flash 2.5 seconds OFF	Overcurrent protection	Overcurrent protection	When 14A (SUZ-KA25VA(H))/24A (SUZ-KA35VA(H)) current flow into intelligent power module (IPM).	<ul style="list-style-type: none"> <li>•Reconnect compressor connector.</li> <li>•Check the inverter/compressor.</li> <li>•Check the stop valve.</li> </ul>
12-time flash 2.5 seconds OFF		Compressor synchronous abnormality (Compressor start-up failure protection)	When waveform of compressor current is distorted.	<ul style="list-style-type: none"> <li>•Reconnect compressor connector.</li> <li>•Check the inverter/compressor.</li> </ul>
Lighting	Refrigerant system	Discharge temperature overheat protection	When discharge temperature exceeds 116°C.	<ul style="list-style-type: none"> <li>•Check the refrigerant circuit and refrigerant amount.</li> <li>•Check the LEV.</li> <li>•Check the outdoor thermistors.</li> </ul>
	High pressure protection	High pressure protection (Overheat protection)	When the indoor coil thermistor (TH5) exceeds 70°C in HEAT mode. When the defrost thermistor exceeds 70°C in COOL mode.	<ul style="list-style-type: none"> <li>•Check refrigerant circuit and refrigerant amount.</li> <li>•Check the stop valve.</li> </ul>
	Low discharge temperature	Low discharge temperature protection	When discharge temperature has been 50°C or less for 20 minutes.	<ul style="list-style-type: none"> <li>•Check the refrigerant circuit and refrigerant amount.</li> <li>•Check the LEV.</li> </ul>
	Outdoor fan	Outdoor fan protection	When outdoor fan has stopped within 30 seconds 3 times in a row after outdoor fan start-up, unit stops.	<ul style="list-style-type: none"> <li>•Check the outdoor fan motor.</li> <li>•Check the inverter P.C. board.</li> </ul>
	Outdoor power system (※)	Outdoor power system	When it consecutively occurs 3 times that the compressor stops for overcurrent protection or start-up failure protection within 1 minute after start-up.	<ul style="list-style-type: none"> <li>•Reconnect compressor connector.</li> <li>•Check the inverter/compressor.</li> <li>•Check the stop valve.</li> </ul>

※ Operation indicator lamp of the indoor unit (only the wireless remote controller use model) blinks twice. Refer to 12-2-1. ※3 and 12-2-3. [Outdoor pattern B].

**SUZ-KA50VA SUZ-KA60VA SUZ-KA71VA (Except for SUZ-KA50VAR2.TH)**

Outdoor LED indication		Abnormal point (Failure mode)	Details of abnormal	Detecting method	Check point
LED1	LED2				
Lighting	Once	Outdoor thermistors	Discharge temperature thermistor	When a short circuit is detected in the thermistor during operation, or when an open circuit is detected in the thermistor after 10 minutes of compressor start-up.	• Check the outdoor thermistors.
			Defrost thermistor	When a short circuit is detected in the thermistor during operation, or when an open circuit is detected in the thermistor after 5 minutes of compressor start-up.	
			Ambient temperature thermistor	When a short or open circuit is detected in the thermistor during operation.	
			Fin temperature thermistor		
			P.C. board temperature thermistor		
	Twice				• Replace the outdoor electronic control P.C. board.
	3 times				
	4 times				
	9 times		Outdoor heat exchanger temperature thermistor	When a short circuit is detected in the thermistor during operation, or when an open circuit is detected in the thermistor after 5 minutes (in cooling) and 10 minutes (in heating) of compressor start-up.	• Check the outdoor thermistors.
	5 times	Outdoor control system	EEPROM	When nonvolatile memory data cannot be read properly, unit stops.	• Replace the outdoor electronic control P.C. board.
6 times	Converter control system	Communication error between P.C. boards	When the communication between boards protection stop is continuously performed twice.	• Check the connecting wire between outdoor electronic control P.C. board and power board.	
		Communication between P.C. boards protection	Communication error occurs between the electronic control P.C. board and power board for more than 10 seconds.		
		7 times	Current sensor	Current sensor protection stop is continuously performed twice.	• Replace the power board.
			Current sensor protection	When a short or open circuit is detected in the current sensor during compressor operating.	
5 times	Goes out	Zero cross detecting circuit	The protection stop of the zero cross detecting circuit is continuously performed 10 times.	• Check the connecting wire among electronic control P.C. board, noise filter P.C. board and power board.	
		Zero cross detecting circuit protection	When zero cross signal cannot be detected while the compressor is operating.		
		Converter protection	When a failure is detected in the operation of the converter during operation.	• Replace the power board.	
		Bus-bar voltage protection (1)	When the bus-bar voltage exceeds 400V or falls to 200V or below during compressor operating.		
6 times	Goes out	Bus-bar voltage protection (2) *Even if this protection stop is performed continuously 3 times, it does not mean the abnormality in outdoor power system.	When the bus-bar voltage exceeds 400V or falls to 50V or below during compressor operating.		

Outdoor LED indication		Abnormal point (Failure mode)	Details of abnormal	Detecting method	Check point
LED1	LED2				
Once	Goes out	Overcurrent protection	IPM protection	When overcurrent is detected after 30 seconds of compressor start-up.	<ul style="list-style-type: none"> <li>• Check the connection of the compressor connecting wire.</li> <li>• Check the inverter/ compressor.</li> <li>• Check the stop valve.</li> </ul>
			Lock protection	When overcurrent is detected within 30 seconds after the compressor gets started.	
3 times	Goes out	Fin temperature/P.C. board temperature overheat	Fin temperature overheat protection	When the fin temperature exceeds 87°C during operation.	<ul style="list-style-type: none"> <li>• Check around outdoor unit.</li> <li>• Check outdoor unit air passage.</li> <li>• Check the outdoor fan motor.</li> </ul>
4 times	Goes out		P.C. board temperature overheat protection	When the P.C. board temperature exceeds 70°C during operation.	
Lighting	Lighting	Refrigerant system	Discharge temperature overheat protection	When discharge temperature exceeds 116°C.	<ul style="list-style-type: none"> <li>• Check refrigerant circuit and refrigerant amount.</li> <li>• Check the LEV.</li> <li>• Check the outdoor thermistors.</li> </ul>
		High pressure protection	HPS protection	When high-pressure is detected with the high-pressure switch (HPS) during operation.	
			High pressure protection (Overheat protection)	When the indoor coil thermistor (TH5) exceeds 70°C in HEAT mode. When the outdoor heat exchanger thermistor exceeds 70°C in COOL mode.	
		Low discharge temperature	Low discharge temperature protection	When the frequency of the compressor is kept 80Hz or more and discharge temperature is kept under 39°C for more than 20 minutes.	<ul style="list-style-type: none"> <li>• Check refrigerant circuit and refrigerant amount.</li> <li>• Check the LEV.</li> </ul>
		Outdoor fan	Outdoor fan protection	When outdoor fan has stopped within 30 seconds 3 times in a row after outdoor fan start-up, unit stops.	<ul style="list-style-type: none"> <li>• Check the outdoor fan motor.</li> </ul>
Outdoor power system	Outdoor power system	When IPM protection stop or lock protection stop is continuously performed 3 times within 1 minute after the compressor get started, or when converter protection stop or bus-bar voltage protection stop is continuously performed 3 times within 3 minutes after start-up.	<ul style="list-style-type: none"> <li>• Reconnect compressor connector.</li> <li>• Check the inverter/ compressor.</li> <li>• Check the stop valve.</li> <li>• Check the PAM module.</li> </ul>		

**SUZ-KA25VA(H)R1.TH    SUZ-KA35VA(H)R1.TH    SUZ-KA50VAR2.TH**

Abnormal point (Failure mode/protection)	LED indication (Outdoor P.C. board)	Condition	Correspondence
None (Normal)	—	—	—
Outdoor power system	—	Overcurrent protection stop is continuously performed 3 times within 1 minute after the compressor gets started.	<ul style="list-style-type: none"> <li>•Reconnect connectors.</li> <li>•Refer to 12-5. Ⓜ "How to check inverter/compressor".</li> <li>•Check stop valve.</li> </ul>
Discharge temperature thermistor	1-time flash every 2.5 seconds	Thermistor shorts or opens during compressor running.	<ul style="list-style-type: none"> <li>•Refer to 12-5. Ⓜ "Check of outdoor thermistors". Defective outdoor thermistors can be identified by checking the blinking pattern of LED.</li> </ul>
Defrost thermistor	—		
Fin temperature thermistor	3-time flash 2.5 seconds OFF		
P.C. board temperature thermistor	4-time flash 2.5 seconds OFF		
Ambient temperature thermistor	2-time flash 2.5 seconds OFF		
Overcurrent	11-time flash 2.5 seconds OFF	Large current flows into intelligent power module.	<ul style="list-style-type: none"> <li>•Reconnect compressor connector.</li> <li>•Refer to 12-5. Ⓜ "How to check inverter/compressor".</li> <li>•Check stop valve.</li> </ul>
Compressor synchronous abnormality (Compressor start-up failure protection)	12-time flash 2.5 seconds OFF	Waveform of compressor current is distorted.	<ul style="list-style-type: none"> <li>•Reconnect compressor connector.</li> <li>•Refer to 12-5. Ⓜ "How to check inverter/compressor".</li> </ul>
Discharge temperature	—	Temperature of discharge temperature thermistor exceeds 116°C, compressor stops. Compressor can restart if discharge temperature thermistor reads 100°C or less 3 minutes later.	<ul style="list-style-type: none"> <li>•Check refrigerant circuit and refrigerant amount.</li> <li>•Refer to 12-5. Ⓜ "Check of LEV".</li> </ul>
High pressure	—	Temperature indoor coil thermistor exceeds 70°C in HEAT mode. Temperature defrost thermistor exceeds 70°C in COOL mode.	<ul style="list-style-type: none"> <li>•Check refrigerant circuit and refrigerant amount.</li> <li>•Check stop valve.</li> </ul>
Fin temperature/P.C. board temperature	7-time flash 2.5 seconds OFF	Temperature of fin temperature thermistor on the inverter P.C. board exceeds 75 ~ 80°C, or temperature of P.C. board temperature thermistor on the inverter P.C. board exceeds 70 ~ 75°C.	<ul style="list-style-type: none"> <li>•Check around outdoor unit.</li> <li>•Check outdoor unit air passage.</li> <li>•Refer to 12-5. Ⓜ "Check of outdoor fan motor".</li> </ul>
Outdoor fan motor	—	Outdoor fan has stopped 3 times in a row within 30 seconds after outdoor fan start-up.	<ul style="list-style-type: none"> <li>•Refer to 12-5. Ⓜ "Check of outdoor fan motor".</li> <li>Refer to 11-5. Ⓜ "Check of inverter P.C. board".</li> </ul>
Nonvolatile memory data	5-time flash 2.5 seconds OFF	Nonvolatile memory data cannot be read properly.	<ul style="list-style-type: none"> <li>•Replace the inverter P.C. board.</li> </ul>
Discharge temperature	—	Temperature of discharge temperature thermistor has been 50°C or less for 20 minutes.	<ul style="list-style-type: none"> <li>•Refer to 12-5. Ⓜ "Check of LEV".</li> <li>•Check refrigerant circuit and refrigerant amount.</li> </ul>
DC voltage	8-time flash 2.5 seconds OFF	DC voltage of inverter cannot be detected normally.	<ul style="list-style-type: none"> <li>•Refer to 12-5. Ⓜ "How to check inverter/compressor".</li> </ul>
Each phase current of compressor	9-time flash 2.5 seconds OFF	Each phase current of compressor cannot be detected normally.	
Overcurrent Compressor open-phase	10-time flash 2.5 seconds OFF	Large current flows into intelligent power module (IPM). The open-phase operation of compressor is detected. The interphase short out occurs in the output of the intelligent power module (IPM). The compressor winding shorts out.	<ul style="list-style-type: none"> <li>•Reconnect compressor connector.</li> <li>•Refer to 12-5. Ⓜ "How to check inverter/compressor".</li> </ul>
Stop valve (Closed valve)	14-time flash 2.5 seconds OFF	Closed valve is detected by compressor current.	<ul style="list-style-type: none"> <li>•Check stop valve</li> </ul>

**NOTE:** Blinking patterns of this mode differ from the ones of Troubleshooting check table (12-3.).



### 12-3. Troubleshooting check table SUZ-KA25VA(H)SUZ-KA35VA(H) (Except for SUZ-KA25/35VA(H)R1.TH)

Inverter P.C. board (Parts side)

NOTE 1. The location of LED is illustrated at the right figure. Refer to 12-6-1.  
2. LED lights up during normal operation.

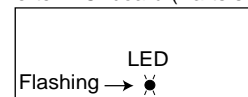

No.	Symptom	LED indication	Abnormal point/ Condition	Detection method	Check point	
1	Outdoor unit does not operate	1-time flash every 2.5 seconds	Outdoor power system	When it consecutively occurs 3times that the compressor stops for overcurrent protection or start-up failure protection within 1minute start-up.	<ul style="list-style-type: none"> <li>Check stop valve.</li> <li>Reconnect connector of compressor.</li> <li>Refer to 12-5.② "How to check inverter/ compressor".</li> </ul>	
2			Outdoor thermistors	When discharge temperature thermistor, fin temperature thermistor, defrost thermistor, P.C. board temperature thermistor or ambient temperature thermistor shorts or opens during compressor running.When discharge temperature	<ul style="list-style-type: none"> <li>Refer to 12-5.③ "Check of outdoor thermistors".</li> </ul>	
3			Outdoor control system	When nonvolatile memory data cannot be read properly, compressor stops.	Replace inverter P.C. board.	
4			6-time flash 2.5 seconds OFF	Serial signal	When the communication failure between the indoor and outdoor unit for 3 minutes.	Refer to 12-5.④ "How to check mis-wiring and serial signal error.
5			14-time flash 2.5 seconds OFF	Outdoor unit (Other abnormality)	When outdoor unit is defective.	Refer to 12-2-3. Check [output pattern B]
6	'Outdoor unit stops and restarts 3 minutes later' is repeated	2-time flash 2.5 seconds OFF	Overcurrent protection	When 14A (SUZ-KA25VA(H))/24A (SUZ-KA35VA(H)) current flows into intelligent power module.	<ul style="list-style-type: none"> <li>Check stop valve.</li> <li>Reconnect connector of compressor.</li> <li>Refer to 12-5.② "How to check inverter/compressor".</li> </ul>	
7			Discharge temperature overheat protection	When discharge temperature thermistor exceeds 116°C, compressor stops. Compressor can restart if discharge temperature thermistor reads 100°C or less 3 minutes later.	<ul style="list-style-type: none"> <li>Check refrigerant circuit and refrigerant amount.</li> <li>Refer to 12-5.① "Check of LEV".</li> </ul>	
8			Fin temperature /P.C. board temperature thermistor overheat protection	When temperature of fin temperature thermistor on the heat sink exceeds 83°C (SUZ-KA25VA(H))/82°C (SUZ-KA35VA(H)) or temperature of P.C. board temperature thermistor exceeds 85°C (SUZ-KA25VA(H))/81°C (SUZ-KA35VA(H)), compressor stops and restarts 3 minutes later.	<ul style="list-style-type: none"> <li>Check around outdoor unit.</li> <li>Check outdoor unit air passage.</li> <li>Refer to 12-5.① "Check of outdoor fan motor".</li> </ul>	
9			High pressure protection	When indoor coil thermistor exceeds 70°C in HEAT mode. When the defrost thermistor exceeds 70°C in COOL mode.	<ul style="list-style-type: none"> <li>Check refrigerant circuit and refrigerant amount.</li> <li>Check stop valve.</li> </ul>	
10			Compressor synchronous abnormality	When the waveform of compressor current is distorted.	<ul style="list-style-type: none"> <li>Reconnect connector of compressor.</li> <li>Refer to 12-5.② "How to check inverter/compressor".</li> </ul>	
11			Outdoor fan	When outdoor fan has stopped within 30 seconds 3 times a row after outdoor fan start-up, unit stops.	<ul style="list-style-type: none"> <li>Refer to 12-5.① "Check of outdoor fan motor.</li> <li>Refer to 12-5.③ "Check of inverter P.C. board.</li> </ul>	
12			Each phase current of compressor	When compressor each phase current cannot be detected normally	Refer to 12-5.② "How to check inverter/compressor".	
13			DC voltage	When DC voltage of inverter cannot be detected normally.	Refer to 12-5.② "How to check inverter/compressor".	
14			Outdoor unit operates	1-time flash 2.5 seconds OFF	Frequency drop by current protection	When current from power outlet exceeds 6.1A (SUZ-KA25VA(H))/9.2A (SUZ-KA35VA(H)), compressor frequency lowers.
15	Frequency drop by high pressure protection	When indoor coil thermistor exceeds 55°C in HEAT mode, compressor frequency lowers.				
16	Frequency drop by defrosting in COOL mode	When indoor coil thermistor reads 8°C or less in COOL mode, compressor frequency lowers.				
16	Outdoor unit operates	4-time flash 2.5 seconds OFF	Frequency drop by discharge temperature protection	When discharge temperature thermistor exceeds 111°C, compressor frequency lowers.	<ul style="list-style-type: none"> <li>Check refrigerant circuit and refrigerant amount.</li> <li>Refer to 12-5.① "Check of LEV".</li> <li>Refer to 12-5.③ "Check of outdoor thermistors".</li> </ul>	
17			Low discharge temperature protection	When discharge temperature has been 50°C or less for 20 minutes.	<ul style="list-style-type: none"> <li>Refer to 12-5.① "Check of LEV".</li> <li>Check refrigerant circuit and refrigerant amount.</li> </ul>	
18			PAM protection	When the overcurrent flows into IGBT (Insulated Gate Bipolar transistor : TR821) or when the bus-bar voltage reaches 320V or more, PAM stops and restarts.	This is not malfunction. PAM protection will be activated in the following cases; <ul style="list-style-type: none"> <li>① Instantaneous power voltage drop (Short time power failure)</li> <li>② When the power supply voltage is high.</li> </ul>	
19	Outdoor unit operates	9-time flash 2.5 seconds OFF	Inverter check mode	When the connector of compressor is disconnected, inverter check mode starts.	Check if the connector of the compressor is correctly connected. Refer to 12-5.② "How to check inverter/ compressor".	

The flashing frequency shows the number of times the LED blinks after every 2.5-second OFF.  
(Example) When the flashing frequency is "2".

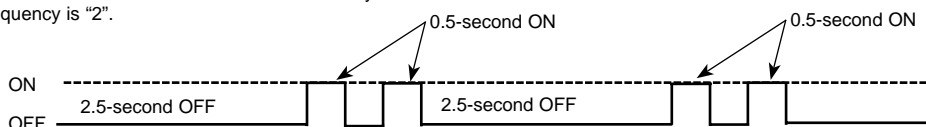

## SUZ-KA50VA SUZ-KA60VA SUZ-KA71VA (Except for SUZ-KA50VAR2.TH)

No.	Symptom	Indication		Abnormal point/Condition	Condition	Correspondence
		LED1 (Red)	LED2 (Yellow)			
1	Outdoor unit does not operate.	Lightning	Twice	Outdoor power system	When IPM protection stop or lock protection stop is continuously performed three times within 1 minute after the compressor gets started, or when converter protection stop or bus-bar voltage protection stop is continuously performed three times within 3 minutes after start-up.	<ul style="list-style-type: none"> <li>Check the connection of the compressor connecting wire.</li> <li>Refer to 12-5.⑩ "How to check inverter/compressor".</li> <li>Check the stop valve.</li> </ul>
2			3 times	Discharge temperature thermistor	When a short circuit is detected in the thermistor during operation, or when an open circuit is detected in the thermistor after 10 minutes of compressor start-up.	<ul style="list-style-type: none"> <li>Refer to 12-5.⑨ "Check of outdoor thermistor".</li> </ul>
3		Lightning	4 times	Fin temperature thermistor	When a short or open circuit is detected in the thermistor during operation.	<ul style="list-style-type: none"> <li>Refer to 12-5.⑨ "Check of outdoor thermistor".</li> <li>Replace the outdoor electronic control P.C. board.</li> </ul>
				P.C. board temperature thermistor		
4		Lightning	5 times	Ambient temperature thermistor	When a short or open circuit is detected in the thermistor during operation.	<ul style="list-style-type: none"> <li>Refer to 12-5.⑨ "Check of outdoor thermistor".</li> </ul>
				Outdoor heat exchanger temperature thermistor	When a short circuit is detected in the thermistor during operation, or when an open circuit is detected in the thermistor after 5 minutes (in cooling) and 10 minutes (in heating) of compressor start-up.	
				Defrost thermistor	When a short circuit is detected in the thermistor during operation, or when an open circuit is detected in the thermistor after 5 minutes of compressor start-up.	
5		Lightning	6 times	Serial signal	When the communication fails between the indoor and outdoor unit for 3 minutes.	Refer to 12-5.⑧ "How to check mis-wiring and serial signal error".
6		Lightning	7 times	Nonvolatile memory data	When the nonvolatile memory data cannot be read properly.	<ul style="list-style-type: none"> <li>Replace the outdoor electronic control P.C. board.</li> </ul>
7		Lightning	8 times	Current sensor	Current sensor protection stop is continuously performed twice.	<ul style="list-style-type: none"> <li>Replace the power board.</li> </ul>
8		Lightning	11 times	Communication error between P.C. boards	When the communication protection stop between boards is continuously performed twice.	<ul style="list-style-type: none"> <li>Check the connecting wire between outdoor electronic control P.C. board and power board.</li> </ul>
9		Lightning	12 times	Zero cross detecting circuit	The protection stop of the zero cross detecting circuit is continuously performed 10 times.	<ul style="list-style-type: none"> <li>Check the connecting wire among outdoor electronic control P.C. board, noise filter P.C. board and power board.</li> </ul>
10	Outdoor unit stops and restarts 3 minutes later' is repeated.	Twice	Goes out	IPM protection	When over-current is detected after 30 seconds of compressor start-up.	<ul style="list-style-type: none"> <li>Reconnect compressor connector.</li> <li>Refer to 12-5.⑩ "How to check inverter/compressor".</li> <li>Check the stop valve.</li> <li>Check the power module (PAM module).</li> </ul>
				Lock protection	When over-current is detected within 30 seconds of compressor start-up.	
11	3 times	Goes out	Discharge temperature protection	When temperature of discharge temperature thermistor exceeds 116°C, compressor stops. Compressor can restart if discharge temperature thermistor reads 100°C or less 3 minutes later.	<ul style="list-style-type: none"> <li>Check the amount of gas and refrigerant circuit.</li> <li>Refer to 12-5.⑩ "Check of LEV".</li> </ul>	
12	4 times	Goes out	Fin temperature protection	When the fin temperature exceeds 87°C during operation.	<ul style="list-style-type: none"> <li>Check refrigerant circuit and refrigerant amount.</li> <li>Refer to 12-5.⑩ "Check of LEV".</li> </ul>	
			P.C. board temperature protection	When the P.C. board temperature exceeds 70°C during operation.		
13	5 times	Goes out	High-pressure protection	When high-pressure is detected with the high-pressure switch (HPS) during operation.	<ul style="list-style-type: none"> <li>Check around of gas and the refrigerant circuit.</li> <li>Check of stop valve.</li> </ul>	
				When the outdoor heat exchanger temperature exceeds 70°C during cooling or when indoor gas pipe temperature exceeds 70°C during heating.		
14	8 times	Goes out	Converter protection	When a failure is detected in the operation of the converter during operation.	<ul style="list-style-type: none"> <li>Replace the power board.</li> </ul>	
15	9 times	Goes out	Bus-bar voltage protection (1)	When the bus-bar voltage exceeds 400V or falls to 200V or below during compressor operating.	<ul style="list-style-type: none"> <li>Replace the power board.</li> </ul>	
			Bus-bar voltage protection (2)	When the bus-bar voltage exceeds 400V or falls to 50V or below during compressor operating.		
16	13 times	Goes out	Outdoor fan motor	When failure occurs continuously three times within 30 seconds after the fan gets started.	<ul style="list-style-type: none"> <li>Refer to 12-5.⑩ "Check of outdoor fan motor".</li> </ul>	
17	Lighting	8 times	Current sensor protection	When a short or open circuit is detected in the current sensor during compressor operating.	<ul style="list-style-type: none"> <li>Replace the power board.</li> </ul>	
18	Lighting	11 times	Communication between P.C. boards protection	Communication error occurs between the outdoor electronic control P.C. board and power board for more than 10 seconds.	<ul style="list-style-type: none"> <li>Check the connecting wire between outdoor electronic control P.C. board and power board.</li> </ul>	
19	Lighting	12 times	Zero cross detecting circuit protection	When zero cross signal cannot be detected while the compressor is operating.	<ul style="list-style-type: none"> <li>Check the connecting wire among outdoor electronic control P.C. board, noise filter P.C. board and power board.</li> </ul>	

NOTE 1. The location of LED is illustrated at the right figure.  
2. LED is lighted during normal operation.

The flashing frequency shows the number of times the LED blinks after every 2.5-second OFF.  
(Example) When the flashing frequency is "2".

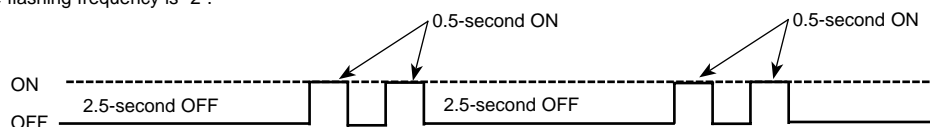

Outdoor electronic control P.C. board (Parts side)

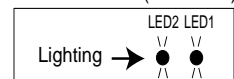



No.	Symptom	Indication		Abnormal point/Condition	Condition	Correspondence
		LED1 (Red)	LED2 (Yellow)			
20	Outdoor unit operates.	Once	Lighting	Primary current protection	When the input current exceeds 15A.	These symptoms do not mean any abnormality of the product, but check the following points. <ul style="list-style-type: none"> <li>• Check if indoor filters are clogged.</li> <li>• Check if refrigerant is short.</li> <li>• Check if indoor/outdoor unit air circulation is short cycled.</li> </ul>
21				Twice	Lighting	
		3 times	Lighting			
22				4 times	Lighting	
		23	5 times			
24				9 times	Lighting	
	25	Lighting	Lighting			Cooling high-pressure protection
26				Lighting	Lighting	Inverter check mode
	26	Lighting	Lighting			Normal

**SUZ-KA25VA(H)R1.TH    SUZ-KA35VA(H)R1.TH    SUZ-KA50VAR2.TH**

No.	Symptom	LED indication	Abnormal point/ Condition	Condition	Correspondence	
1	Outdoor unit does not operate.	1-time flash every 2.5 seconds	Outdoor power system	Overcurrent protection stop is continuously performed 3 times within 1 minute after the compressor gets started, or failure of restart of compressor has repeated 24 times.	<ul style="list-style-type: none"> <li>•Reconnect connector of compressor.</li> <li>•Refer to 12-5. ⓐ "How to check inverter/compressor".</li> <li>•Check stop valve.</li> </ul>	
2			Outdoor thermistors	Discharge temperature thermistor, fin temperature thermistor, defrost thermistor, P.C. board temperature thermistor or ambient temperature thermistor shorts or opens during compressor running.	•Refer to 12-5. ⓐ "Check of outdoor thermistors".	
3			Outdoor control system	Nonvolatile memory data cannot be read properly. (The left lamp of OPERATION INDICATOR lamp of the indoor unit lights up or flashes 7-time.)	•Replace inverter P.C. board.	
4		6-time flash 2.5 seconds OFF	Serial signal	The communication fails between the indoor and outdoor unit for 3 minutes.	•Refer to 11-5. ⓐ "How to check miswiring and serial signal error."	
5		11-time flash 2.5 seconds OFF	Stop valve/ Closed valve	Closed valve is detected by compressor current.	•Check stop valve.	
6		14-time flash 2.5 seconds OFF	Outdoor unit (Other abnormality)	Outdoor unit is defective.	•Refer to 12-2.1. "Flow chart of the detailed outdoor unit failure mode recall function".	
7	'Outdoor unit stops and restarts 3 minutes later' is repeated.	2-time flash 2.5 seconds OFF	Overcurrent protection	Large current flows into intelligent power module, or compressor repeats after 15 seconds when overcurrent protection occurs within 10 seconds after compressor starts. (Repeated 24 times at Maximum)	<ul style="list-style-type: none"> <li>•Reconnect connector of compressor.</li> <li>•Refer to 12-5. ⓐ "How to check inverter/compressor".</li> <li>•Check stop valve.</li> </ul>	
8		3-time flash 2.5 seconds OFF	Discharge temperature overheat protection	Temperature of discharge temperature thermistor exceeds 116°C, compressor stops. Compressor can restart if discharge temperature thermistor reads 100°C or less 3 minutes later.	•Check refrigerant circuit and refrigerant amount. •Refer to 12-5. ⓐ "Check of LEV".	
9		4-time flash 2.5 seconds OFF	Fin temperature/P.C. board temperature thermistor overheat protection	Temperature of fin temperature thermistor on the heat sink exceeds 75 ~ 80°C or temperature of P.C. board temperature thermistor on the inverter P.C. board exceeds 70 ~ 75°C.	•Check around outdoor unit. •Check outdoor unit air passage. •Refer to 12-5. ⓐ "Check of outdoor fan motor".	
10		5-time flash 2.5 seconds OFF	High pressure protection	Indoor coil thermistor exceeds 70°C in HEAT mode. Defrost thermistor exceeds 70°C in COOL mode.	•Check refrigerant circuit and refrigerant amount. •Check stop valve.	
11		8-time flash 2.5 seconds OFF	Compressor synchronous abnormality	The waveform of compressor current is distorted.	•Reconnect connector of compressor. •Refer to 12-5. ⓐ "How to check inverter/compressor".	
12		10-time flash 2.5 seconds OFF	Outdoor fan motor	Outdoor fan has stopped 3 times in a row within 30 seconds after outdoor fan start-up.	•Refer to 12-5. ⓐ "Check of outdoor fan motor." •Refer to 12-5. ⓐ "Check of inverter P.C. board."	
13		12-time flash 2.5 seconds OFF	Each phase current of compressor	Each phase current of compressor cannot be detected normally	•Refer to 12-5. ⓐ "How to check inverter/compressor".	
14		13-time flash 2.5 seconds OFF	DC voltage	DC voltage of inverter cannot be detected normally.	•Refer to 12-5. ⓐ "How to check inverter/compressor".	
15		Outdoor unit operates.	1-time flash 2.5 seconds OFF	Frequency drop by current protection	Current from power outlet reaches the protection current, and compressor frequency lowers.	The unit is normal, but check the following.
16			3-time flash 2.5 seconds OFF	Frequency drop by high pressure protection	Temperature of indoor coil thermistor exceeds 55°C in HEAT mode, compressor frequency lowers.	•Check if indoor filters are clogged. •Check if refrigerant is short. •Check if indoor/outdoor unit air circulation is short cycled.
				Frequency drop by defrosting in COOL mode	Indoor coil thermistor reads 8°C or less in COOL mode, compressor frequency lowers.	
17		4-time flash 2.5 seconds OFF	Frequency drop by discharge temperature protection	Temperature of discharge temperature thermistor exceeds 111°C, compressor frequency lowers.	•Check refrigerant circuit and refrigerant amount. •Refer to 12-5. ⓐ "Check of LEV". •Refer to 12-5. ⓐ "Check of outdoor thermistors".	
18		Outdoor unit operates.	7-time flash 2.5 seconds OFF	Low discharge temperature protection	Temperature of discharge temperature thermistor has been 50°C or less for 20 minutes.	•Refer to 12-5. ⓐ "Check of LEV". •Check refrigerant circuit and refrigerant amount.
19			8-time flash 2.5 seconds OFF	PAM protection PAM: Pulse Amplitude Modulation	The overcurrent flows into IGBT (Insulated Gate Bipolar transistor : TR821) or when the bus-bar voltage reaches 320 V or more, PAM stops and restarts.	This is not malfunction. PAM protection will be activated in the following cases; 1 Instantaneous power voltage drop (Short time power failure) 2 When the power supply voltage is high.
	Inverter check mode			The connector of compressor is disconnected, inverter check mode starts.	•Check if the connector of the compressor is correctly connected. Refer to 12-5. ⓐ "How to check inverter/ compressor".	
20	9-time flash 2.5 seconds OFF					

**NOTE:** 1. The location of LED is illustrated at the right figure. Refer to 12-6-3. or 12-6-7.  
2. LED is lighted during normal operation.

Inverter P.C. board(Parts side)

The flashing frequency shows the number of times the LED blinks after every 2.5-second OFF.  
(Example) When the flashing frequency is "2".

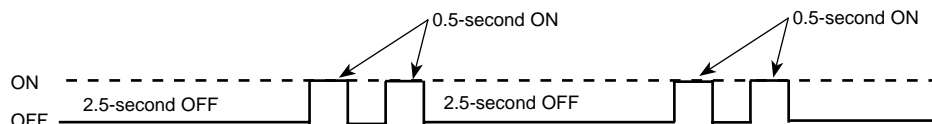
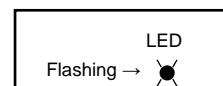

## 12-4. Trouble criterion of main parts (1)

**SUZ-KA25VA.TH SUZ-KA35VA.TH SUZ-KA25VAR1.TH SUZ-KA35VAR1.TH**  
**SUZ-KA25VAH.TH SUZ-KA35VAH.TH SUZ-KA25VAHR1.TH SUZ-KA35VAHR1.TH**

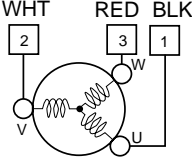
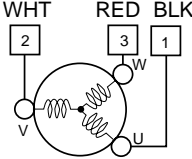
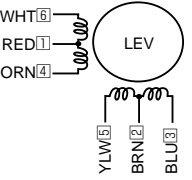
Part name	Check method and criterion	Figure																									
Defrost thermistor (RT61) Fin temperature thermistor (RT64) Ambient temperature thermistor (RT65) Outdoor heat exchanger temperature thermistor (RT68) (SUZ-KA25/35VA(H)R1.TH)	Measure the resistance with a tester.  Refer to 12-6. "Test point diagram and voltage", 12-6-1. or 12-6-3. "Inverter P.C. board", for the chart of thermistor.																										
Discharge temperature thermistor (RT62)	Measure the resistance with a tester. Before measurement, hold the thermistor with your hands to warm it up. Refer to 12-6. "Test point diagram and voltage", 12-6-1. or 12-6-3. "Inverter P.C. board", for the chart of thermistor.																										
Compressor	Measure the resistance between the terminals with a tester. (Part temperature -20°C ~ 40°C) <table border="1"> <thead> <tr> <th></th> <th colspan="4">Normal</th> </tr> <tr> <th></th> <th>SUZ-KA25VA(H).TH</th> <th>SUZ-KA35VA(H).TH</th> <th>SUZ-KA25VA(H)R1.TH</th> <th>SUZ-KA35VA(H)R1.TH</th> </tr> </thead> <tbody> <tr> <td>U-V</td> <td></td> <td></td> <td></td> <td></td> </tr> <tr> <td>U-W</td> <td>1.28 Ω ~ 1.66 Ω</td> <td>0.41 Ω ~ 0.53 Ω</td> <td>1.36 Ω ~ 1.93 Ω</td> <td>1.52 Ω ~ 2.17 Ω</td> </tr> <tr> <td>V-W</td> <td></td> <td></td> <td></td> <td></td> </tr> </tbody> </table>		Normal					SUZ-KA25VA(H).TH	SUZ-KA35VA(H).TH	SUZ-KA25VA(H)R1.TH	SUZ-KA35VA(H)R1.TH	U-V					U-W	1.28 Ω ~ 1.66 Ω	0.41 Ω ~ 0.53 Ω	1.36 Ω ~ 1.93 Ω	1.52 Ω ~ 2.17 Ω	V-W					
	Normal																										
	SUZ-KA25VA(H).TH	SUZ-KA35VA(H).TH	SUZ-KA25VA(H)R1.TH	SUZ-KA35VA(H)R1.TH																							
U-V																											
U-W	1.28 Ω ~ 1.66 Ω	0.41 Ω ~ 0.53 Ω	1.36 Ω ~ 1.93 Ω	1.52 Ω ~ 2.17 Ω																							
V-W																											
Outdoor fan motor	Measure the resistance between the terminals with a tester. (Part temperature -20°C ~ 40°C) <table border="1"> <thead> <tr> <th>Color of the lead wire</th> <th colspan="2">Normal</th> </tr> <tr> <th></th> <th>SUZ-KA25/35VA(H).TH</th> <th>SUZ-KA25/35VA(H)R1.TH</th> </tr> </thead> <tbody> <tr> <td>WHT - BLK</td> <td></td> <td></td> </tr> <tr> <td>BLK - RED</td> <td>31 Ω ~ 41 Ω</td> <td>29 Ω ~ 42 Ω</td> </tr> <tr> <td>RED - WHT</td> <td></td> <td></td> </tr> </tbody> </table>	Color of the lead wire	Normal			SUZ-KA25/35VA(H).TH	SUZ-KA25/35VA(H)R1.TH	WHT - BLK			BLK - RED	31 Ω ~ 41 Ω	29 Ω ~ 42 Ω	RED - WHT													
Color of the lead wire	Normal																										
	SUZ-KA25/35VA(H).TH	SUZ-KA25/35VA(H)R1.TH																									
WHT - BLK																											
BLK - RED	31 Ω ~ 41 Ω	29 Ω ~ 42 Ω																									
RED - WHT																											
R.V. coil	Measure the resistance between the terminals with a tester. (Part temperature -20°C ~ 40°C) <table border="1"> <thead> <tr> <th colspan="2">Normal</th> </tr> <tr> <th>SUZ-KA25/35VA(H).TH</th> <th>SUZ-KA25/35VA(H)R1.TH</th> </tr> </thead> <tbody> <tr> <td>1.20 kΩ ~ 1.55 kΩ</td> <td>1.19 kΩ ~ 1.78 kΩ</td> </tr> </tbody> </table>	Normal		SUZ-KA25/35VA(H).TH	SUZ-KA25/35VA(H)R1.TH	1.20 kΩ ~ 1.55 kΩ	1.19 kΩ ~ 1.78 kΩ																				
Normal																											
SUZ-KA25/35VA(H).TH	SUZ-KA25/35VA(H)R1.TH																										
1.20 kΩ ~ 1.55 kΩ	1.19 kΩ ~ 1.78 kΩ																										
Expansion valve coil (LEV)	Measure the resistance with a tester. (Part temperature : -20°C ~ 40°C) <table border="1"> <thead> <tr> <th>Color of the lead wire</th> <th>Normal</th> </tr> </thead> <tbody> <tr> <td>WHT - RED</td> <td rowspan="4">37 Ω ~ 54 Ω</td> </tr> <tr> <td>RED - ORN</td> </tr> <tr> <td>YLW - BRN</td> </tr> <tr> <td>BRN - BLU</td> </tr> </tbody> </table>	Color of the lead wire	Normal	WHT - RED	37 Ω ~ 54 Ω	RED - ORN	YLW - BRN	BRN - BLU																			
Color of the lead wire	Normal																										
WHT - RED	37 Ω ~ 54 Ω																										
RED - ORN																											
YLW - BRN																											
BRN - BLU																											
Defrost heater SUZ-KA.VAH	Measure the resistance with a tester. (Part temperature -20°C ~ 40°C) <table border="1"> <thead> <tr> <th>Normal</th> </tr> </thead> <tbody> <tr> <td>333 Ω ~ 428 Ω</td> </tr> </tbody> </table>	Normal	333 Ω ~ 428 Ω																								
Normal																											
333 Ω ~ 428 Ω																											

## 12-4. Trouble criterion of main parts (2)

SUZ-KA50VA.TH SUZ-KA50VA<sub>1</sub>.TH SUZ-KA50VAR2.TH

SUZ-KA60VA.TH SUZ-KA60VA<sub>1</sub>.TH SUZ-KA60VAR2.TH

SUZ-KA71VA.TH SUZ-KA71VA<sub>1</sub>.TH

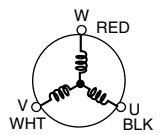
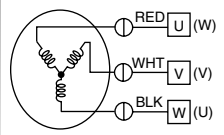
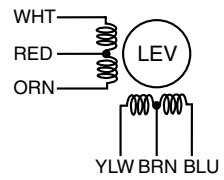
Part name	Check method and criterion	Figure									
Defrost thermistor (RT61) Fin temperature thermistor (RT64) Ambient temperature thermistor (RT65) Outdoor heat exchanger temperature thermistor (RT68)	Measure the resistance with a tester.  Refer to 12-6. "Test point diagram and voltage", 12-6-4. "Outdoor electronic control P.C. board" or 12-6-7. "Inverter P.C. board", for the chart of thermistor.										
Discharge temperature thermistor (RT62)	Measure the resistance with a tester. Before measurement, hold the thermistor with your hands to warm it up.  Refer to 12-6. "Test point diagram and voltage", 12-6-4. "Outdoor electronic control P.C. board" or 12-6-7. "Inverter P.C. board", for the chart of thermistor.										
Compressor	Measure the resistance between the terminals with a tester. (Part temperature -10°C ~ 40°C) <table border="1" style="width: 100%; text-align: center;"> <thead> <tr> <th colspan="3">Normal</th> </tr> <tr> <th>SUZ-KA50/60VA<sub>(1)</sub>.TH</th> <th>SUZ-KA50/60VAR2.TH</th> <th>SUZ-KA71VA<sub>(1)</sub>.TH</th> </tr> </thead> <tbody> <tr> <td>0.40 Ω ~ 0.49 Ω</td> <td>0.86 Ω ~ 1.06 Ω</td> <td>1.29 Ω ~ 1.49 Ω</td> </tr> </tbody> </table>	Normal			SUZ-KA50/60VA <sub>(1)</sub> .TH	SUZ-KA50/60VAR2.TH	SUZ-KA71VA <sub>(1)</sub> .TH	0.40 Ω ~ 0.49 Ω	0.86 Ω ~ 1.06 Ω	1.29 Ω ~ 1.49 Ω	
Normal											
SUZ-KA50/60VA <sub>(1)</sub> .TH	SUZ-KA50/60VAR2.TH	SUZ-KA71VA <sub>(1)</sub> .TH									
0.40 Ω ~ 0.49 Ω	0.86 Ω ~ 1.06 Ω	1.29 Ω ~ 1.49 Ω									
Outdoor fan motor	Measure the resistance between lead wires with a tester. (Part temperature -10°C ~ 40°C) <table border="1" style="width: 100%; text-align: center;"> <thead> <tr> <th>Color of the lead wire</th> <th>Normal</th> </tr> </thead> <tbody> <tr> <td>RED - BLK</td> <td rowspan="3">13.4 Ω ~ 16.4 Ω</td> </tr> <tr> <td>BLK - WHT</td> </tr> <tr> <td>WHT - RED</td> </tr> </tbody> </table>	Color of the lead wire	Normal	RED - BLK	13.4 Ω ~ 16.4 Ω	BLK - WHT	WHT - RED				
Color of the lead wire	Normal										
RED - BLK	13.4 Ω ~ 16.4 Ω										
BLK - WHT											
WHT - RED											
R.V. coil	Measure the resistance with a tester. (Part temperature -10°C ~ 40°C) <table border="1" style="width: 100%; text-align: center;"> <thead> <tr> <th colspan="2">Normal</th> </tr> <tr> <th>SUZ-KA50/60VAR2.TH</th> <th>Other models</th> </tr> </thead> <tbody> <tr> <td>1.32 kΩ ~ 1.62 kΩ</td> <td>2.6 kΩ ~ 3.3 kΩ</td> </tr> </tbody> </table>	Normal		SUZ-KA50/60VAR2.TH	Other models	1.32 kΩ ~ 1.62 kΩ	2.6 kΩ ~ 3.3 kΩ				
Normal											
SUZ-KA50/60VAR2.TH	Other models										
1.32 kΩ ~ 1.62 kΩ	2.6 kΩ ~ 3.3 kΩ										
Expansion valve coil (LEV)	Measure the resistance with a tester. (Part temperature : -10°C ~ 40°C) <table border="1" style="width: 100%; text-align: center;"> <thead> <tr> <th>Color of the lead wire</th> <th>Normal</th> </tr> </thead> <tbody> <tr> <td>WHT - RED</td> <td rowspan="4">37.4 Ω ~ 53.9 Ω</td> </tr> <tr> <td>RED - ORN</td> </tr> <tr> <td>YLW - BRN</td> </tr> <tr> <td>BRN - BLU</td> </tr> </tbody> </table>	Color of the lead wire	Normal	WHT - RED	37.4 Ω ~ 53.9 Ω	RED - ORN	YLW - BRN	BRN - BLU			
Color of the lead wire	Normal										
WHT - RED	37.4 Ω ~ 53.9 Ω										
RED - ORN											
YLW - BRN											
BRN - BLU											
High pressure switch (HPS) SUZ-KA60VAR2.TH SUZ-KA71VA <sub>(1)</sub> .TH	<table border="1" style="width: 100%; text-align: center;"> <thead> <tr> <th colspan="2">Pressure</th> </tr> </thead> <tbody> <tr> <td>3.7 ± 0.15 MPa</td> <td>Close</td> </tr> <tr> <td>4.8 ±<sup>0.05</sup><sub>0.1</sub> MPa</td> <td>Open</td> </tr> </tbody> </table>	Pressure		3.7 ± 0.15 MPa	Close	4.8 ± <sup>0.05</sup> <sub>0.1</sub> MPa	Open				
Pressure											
3.7 ± 0.15 MPa	Close										
4.8 ± <sup>0.05</sup> <sub>0.1</sub> MPa	Open										

## 12-5. Troubleshooting flow

### Outdoor unit does not operate.

#### A How to check inverter/compressor

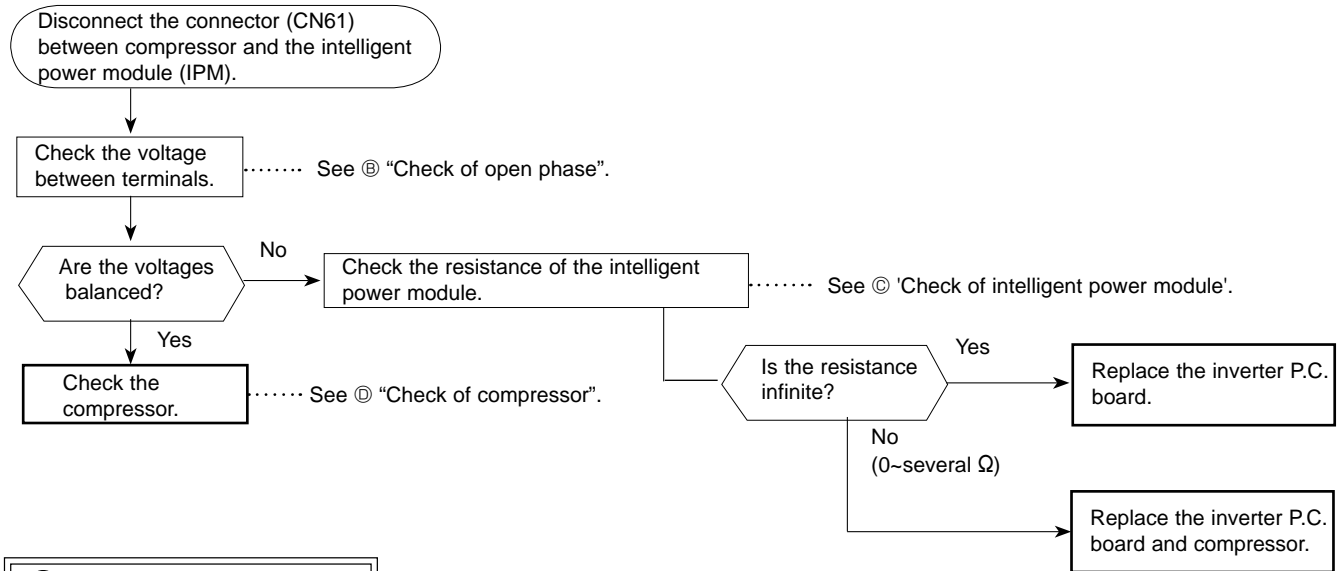

#### B Check of open phase

- With the connector between compressor and the intelligent power module disconnected, activate the inverter and check if the inverter is normal by measuring the balance of voltage between terminals.

Output voltage [V]  
115V

<< Operation method >>

Start cooling or heating operation by pressing the EMERGENCY OPERATION switch on the indoor unit. (test-run mode : refer to page 31 for SLZ/SUZ and 37 for SEZ/SUZ.)

<< Measurement point >> \* Measure AC voltage between the lead wires at 3 points.

BLK (U)-WHT (V)  
BLK (U)-RED (W)  
WHT(V)-RED (W)

NOTE 1. Output voltage varies according to power supply voltage.

2. Measure the voltage by analog type tester.

3. During this check, LED of inverter P.C. board flashes 9 times.

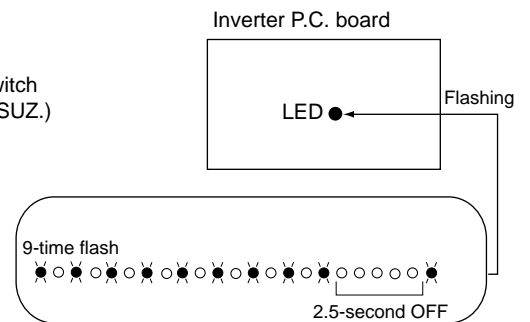

#### C Check of intelligent power module

- Measure the resistance between terminals on the intelligent power module.

<< Measurement point >>  
at 6 points

BLK-WHT, WHT-BLK  
BLK-RED, RED-BLK  
WHT-RED, RED-WHT

<< Judgement >>

Infinite [Ω].....Normal

0~dozens of .....Abnormal (short)

ohmmeter indication

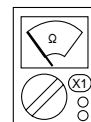

..... Normal  
(infinite)

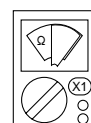

..... Abnormal  
(0~dozens of Ω)

**D Check of compressor**

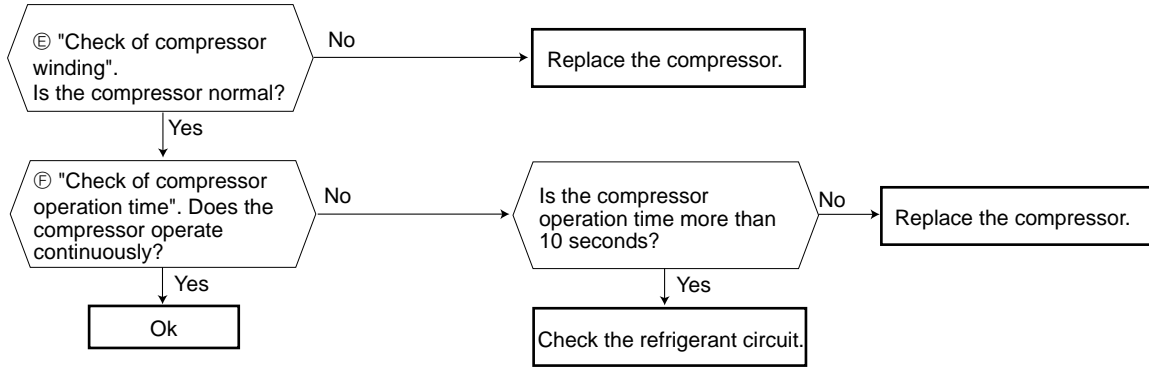

**E Check of compressor winding**

- Disconnect the connector (CN61) between compressor and intelligent power module, and measure the resistance between the compressor terminals.

Measurement point at 3 points of lead wire.

BLK-WHT

BLK-RED

WHT-RED

<<Judgment>>

Refer to 12-4..

0[Ω] .....Abnormal [short]

Infinite[Ω] .....Abnormal [open]

NOTE 1. Be sure to zero the ohmmeter before measurement.

2. Winding resistance for each phase at 20°C .

Refer to 4. SPECIFICATION.

Ohmmeter indication

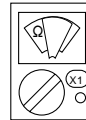

..... Normal  
(1~several Ω)

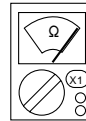

..... Abnormal  
(0Ω ..... short)

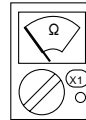

..... Abnormal  
(infinite..... open)

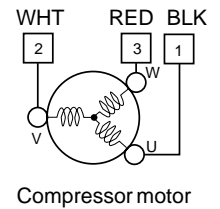

**F Check of compressor operation time**

- Connect the compressor and activate the inverter. Then measure the time until the inverter stops due to over current.

<<Operation method>>

[For wireless remote controller use model]

Start heating or cooling operation by pressing the EMERGENCY OPERATION switch on the indoor unit. (Test-run mode)

[For wired remote controller use model]

Start heating or cooling operation by pressing the TEST button twice on the remote controller. (Test-run mode)

<<Measurement>>

Measure the time from the start of outdoor fan running to the stop of compressor due to over current.

<<Judgment>>

For reference

0~10 seconds.....Abnormal (compressor short or poor contact)  
(compressor lock-out)

10 seconds~5 minutes.....Abnormal (refrigerant circuit defect)

more than 5 minutes.....Normal

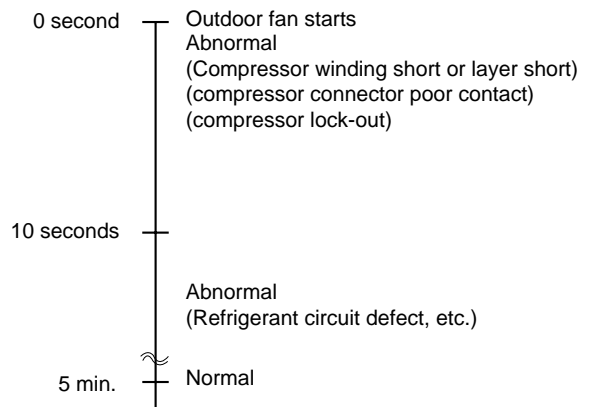



The thermistors in the outdoor unit are abnormal.

**G Check of outdoor thermistors**

Defrost thermistor RT61

Measure the resistance between CN641 ① and ②.

Discharge temperature thermistor RT62

Measure the resistance between CN641 ③ and ④.

Fin temperature thermistor RT64

Measure the resistance between CN642 ① and ②.

Ambient temperature thermistor RT65

Measure the resistance between CN643 ① and ②.

Disconnect the connectors CN641, CN642 and CN643 from the inverter P.C. board. (Check the characteristics of each thermistor.)

Is the resistance of thermistor normal? (Refer to 12-6.1.)

No  
Replace the thermistor except RT64. In case that RT64 is abnormal, replace the inverter P.C. board, since RT64 is combined with the inverter P.C. board.

Yes  
Reconnect the connectors CN641, CN642 and CN643. Turn ON the power supply and press EMERGENCY OPERATION switch (For wireless remote controller use model)./TEST button twice (For wired remote controller use model).

Replace the inverter P.C. board.

Does the unit operate 10 minutes or more?

OK. (Cause is poor contact.)

**H Check of R.V. coil**

\* First of all, measure the resistance of R.V. coil to check if the coil is defective. Refer to 12-4..

\* In case CN721 is not connected or R.V. coil is open, voltage is generated between the terminal pins of the connector although no signal is being transmitted to R.V. coil. Check if CN721 is connected.

**Unit operates COOL mode even if it is set to HEAT mode.**

Disconnect connector (CN61) between compressor and intelligent power module. [For wireless remote controller use model] Turn ON the power supply and press the EMERGENCY OPERATION switch (HEAT switch). [For wired remote controller use model] Turn ON the power supply and press the TEST button twice (HEAT mode).

Is there 230V AC between CN721① and ② on the power P.C. board 3 minutes after the power supply is turned ON?

Yes  
Replace the 4-way valve.

No  
Replace the power P.C. board.

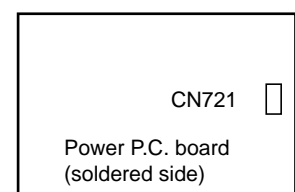

**Unit operates HEAT mode even if it is set to COOL mode.**

Disconnect connector (CN61) between compressor and intelligent power module. [For wireless remote controller use model] Turn ON the power supply and press the EMERGENCY OPERATION switch (COOL switch). [For wired remote controller use model] Turn ON the power supply and press the TEST button twice (COOL mode).

Is there 230V AC between CN721① and ② on the power P.C. board 3 minutes after the power supply is turned ON?

No  
• Defective R.V. coil  
• Defective 4-way valve

Yes  
Replace the power P.C. board.

**Outdoor fan motor does not operate.**

**① Check of outdoor fan motor**

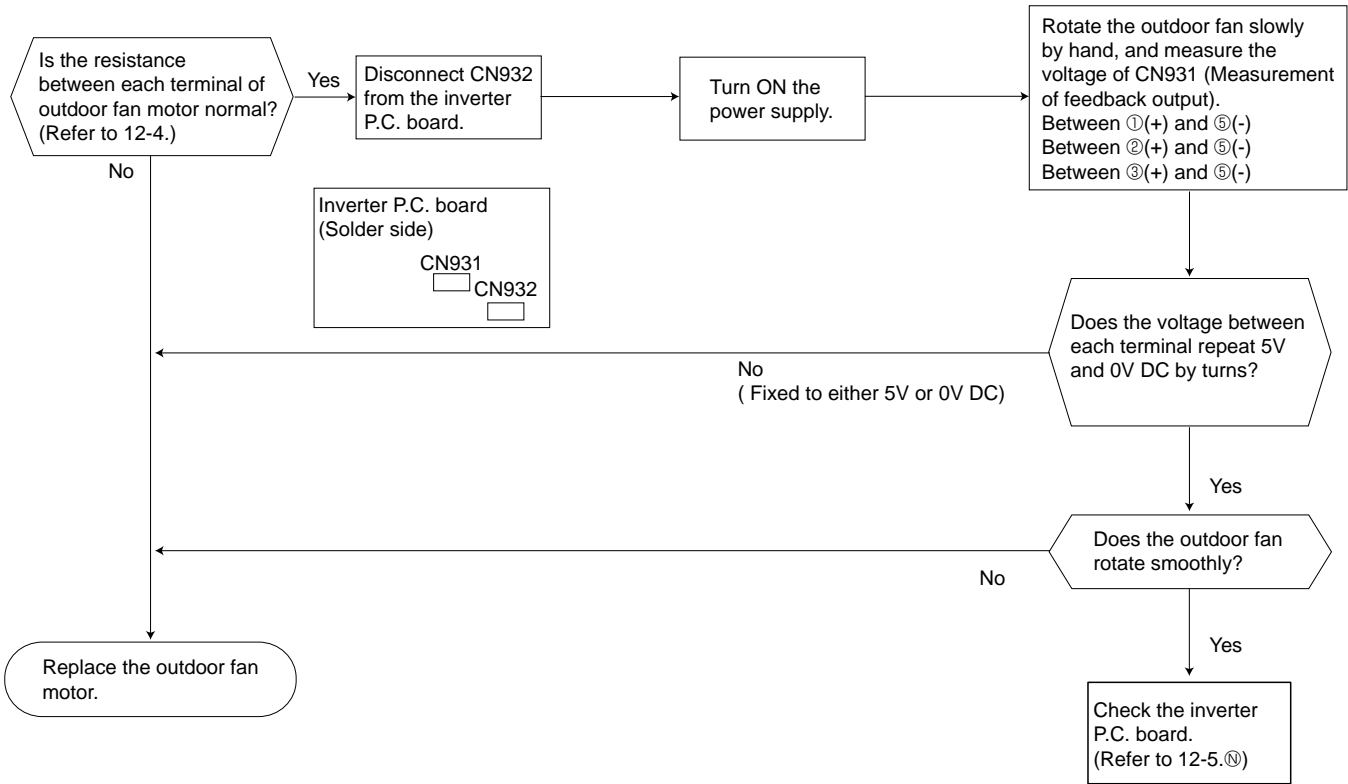

**Inverter does not operate.**

**② Check of power supply**

Disconnect the connector (CN61) between compressor and intelligent power module.  
 [For wireless remote controller use model]  
 Turn ON power supply and press EMERGENCY OPERATION switch.  
 [For wired remote controller use model]  
 Turn ON the power supply and press the TEST button twice.

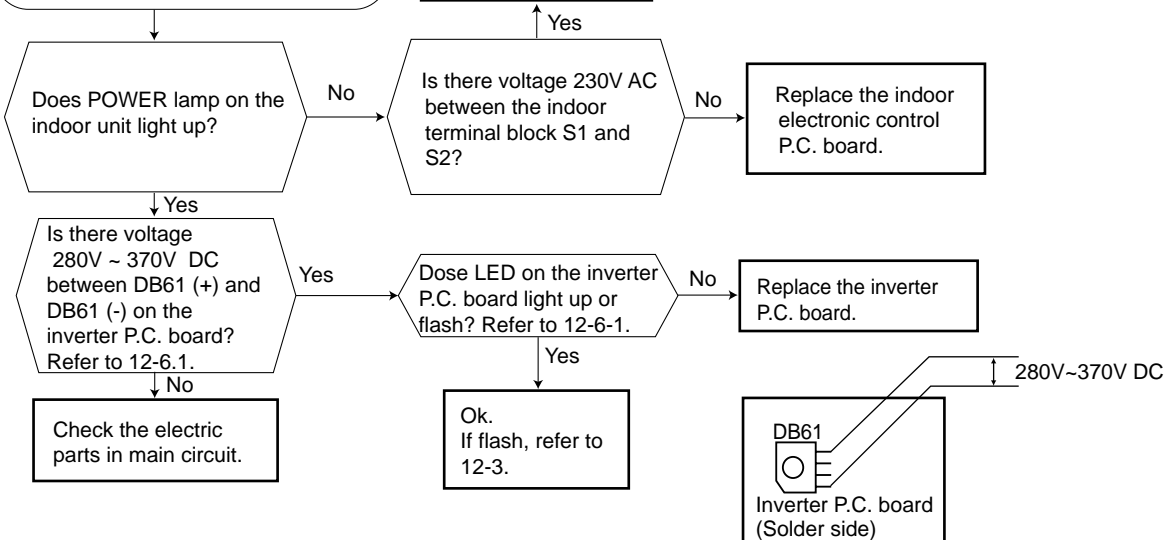

Outdoor unit does not operate at all or stops immediately due to over current.

**K Check of current limiting resistor**

When the current-limiting resistor is open, the rush current limiting relay (X64) may not work properly.

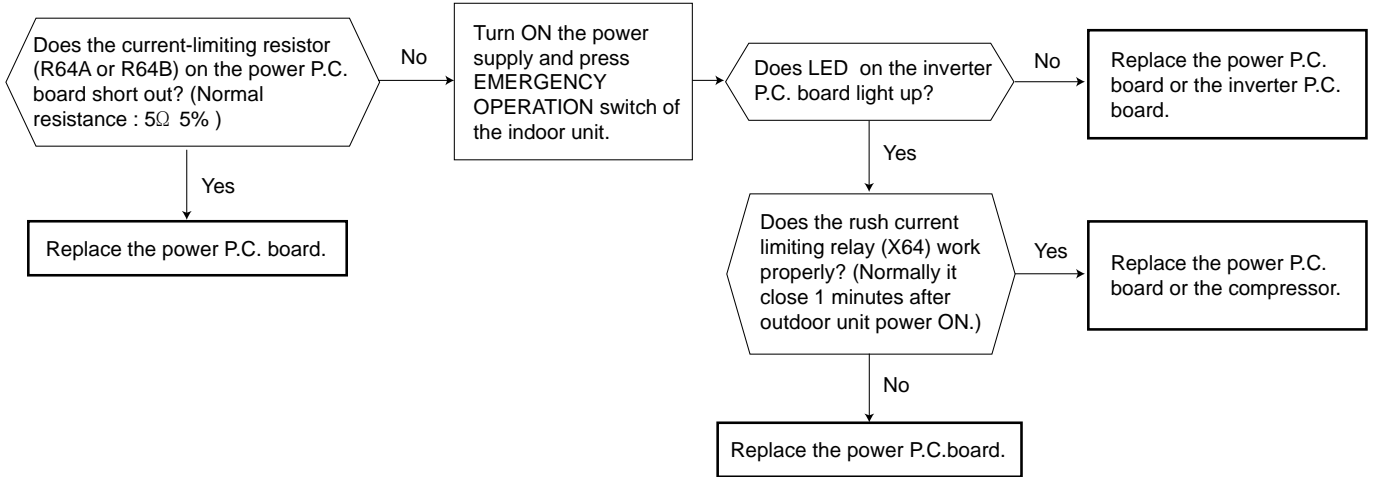

- Check other electric parts in the main circuit together in the case of the defective current-limiting resistor.

Heating/Cooling does not work sufficiently.

**L Check of LEV (Expansion valve)** (For wireless remote controller use model)

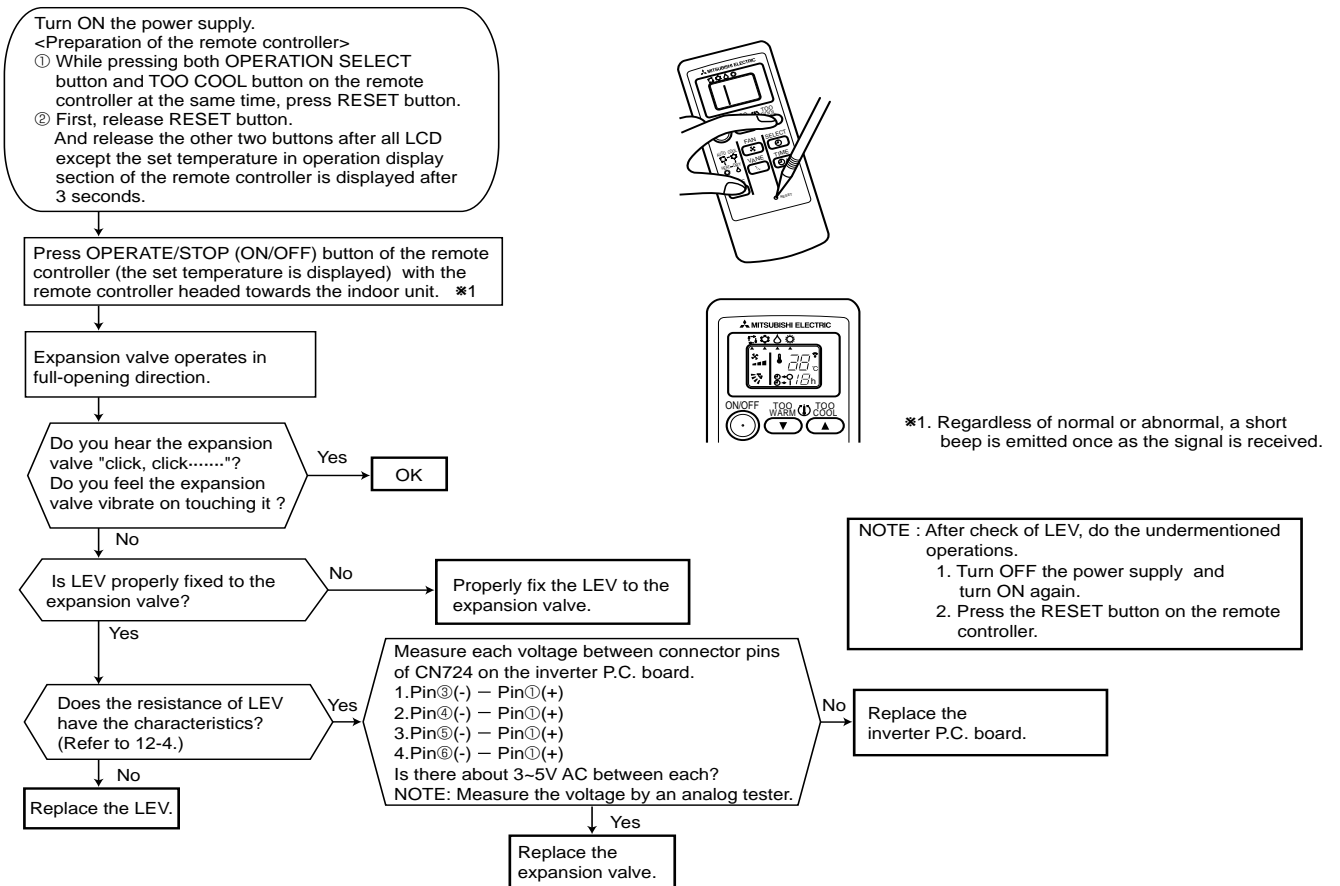

**L Check of LEV (Expansion valve)** (For wired remote controller use model)

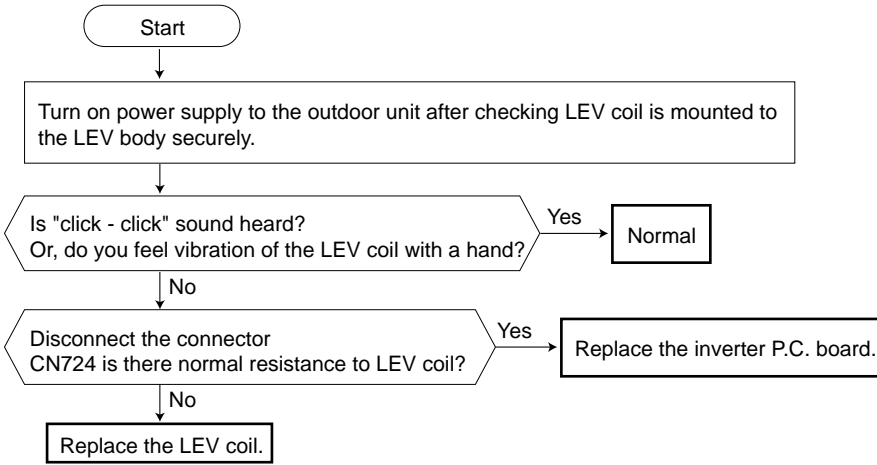

**Outdoor base gets frozen.**

**M Check of defrost heater** <SUZ-KA25VAH SUZ-KA35VAH>

Check the following points before checking electric continuity.

- 1) Does the resistance of ambient temperature thermistor have the characteristics? Refer to 12-6-1.
- 2) Is the resistance of defrost heater normal? Refer to 12-4.
- 3) Does the heater protector remain conducted (not open)?
- 4) Are both ambient temperature thermistor and circuit of defrost heater securely connected to connectors?

In HEAT mode, for more than 5 minutes, let the ambient temperature thermistor continue to read 5°C or less, and let the defrost thermistor continue to read -1°C or less.

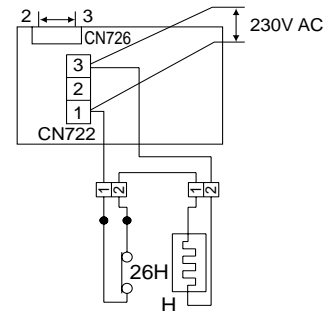
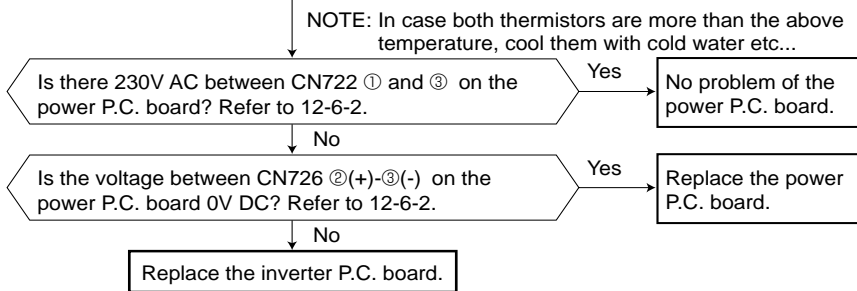

Outdoor fan motor does not operate, or stops immediately after starting up.

**N Check of inverter P.C. board**

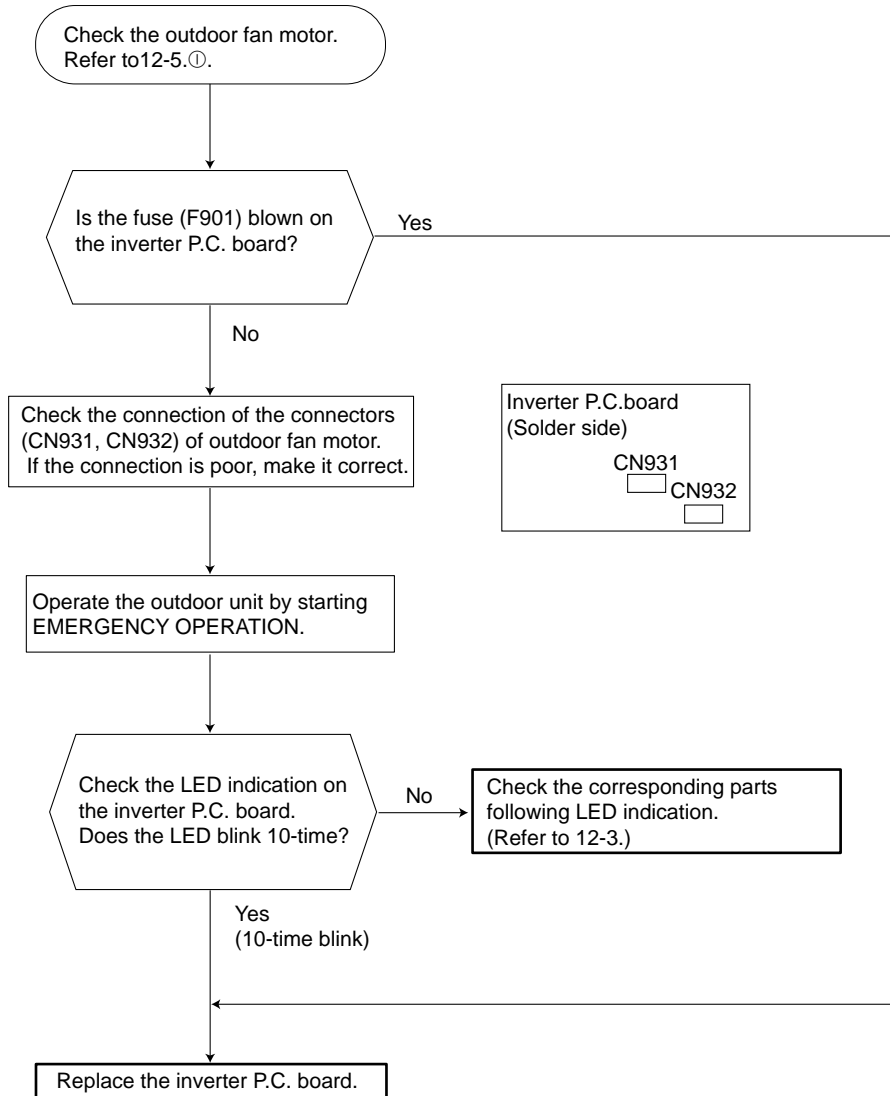

⊙ How to check miswiring and serial signal error (when outdoor unit does not work)

(For wireless remote controller use model)

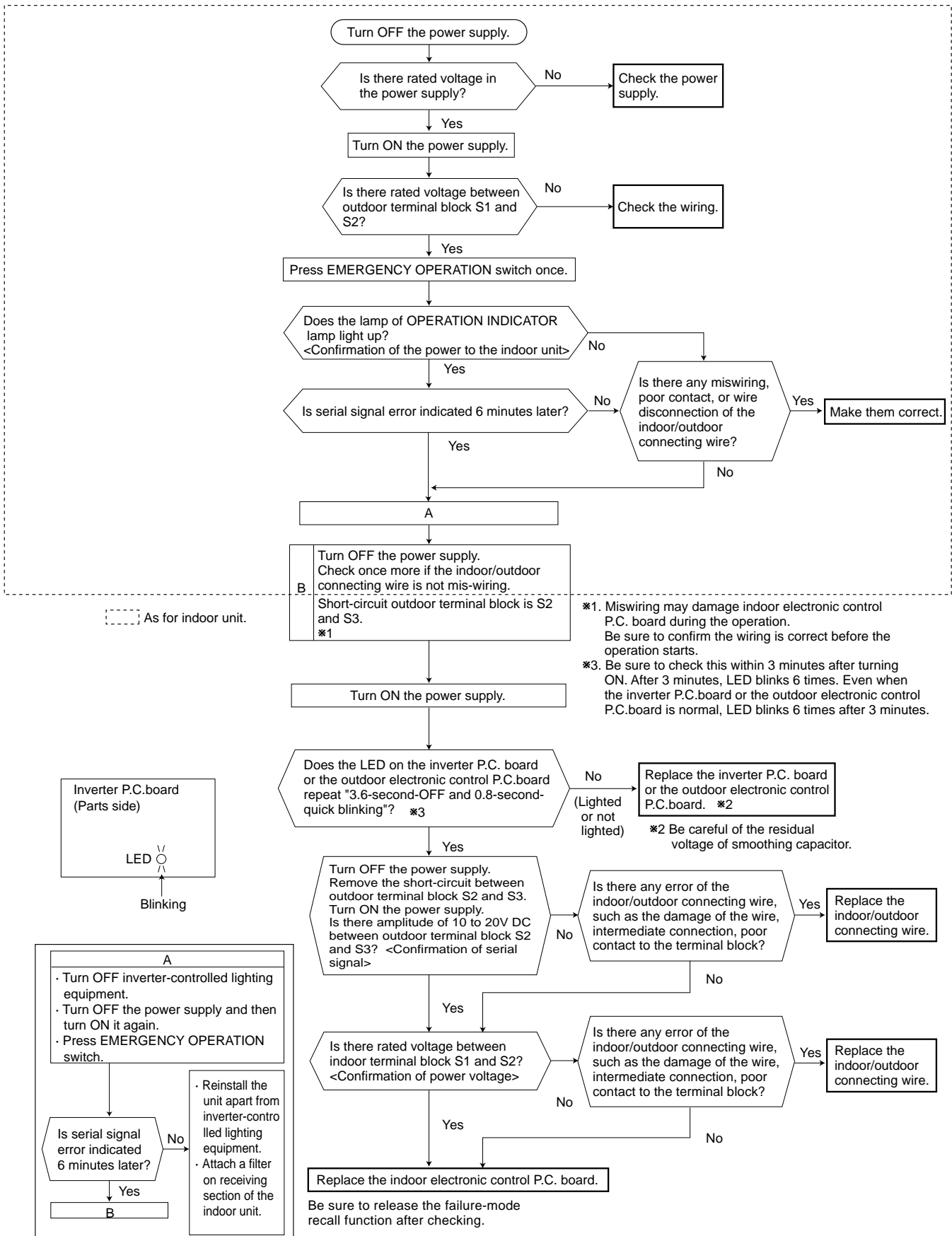

⊙ How to check miswiring and serial signal error (when outdoor unit does not work)

(For wired remote controller use model)

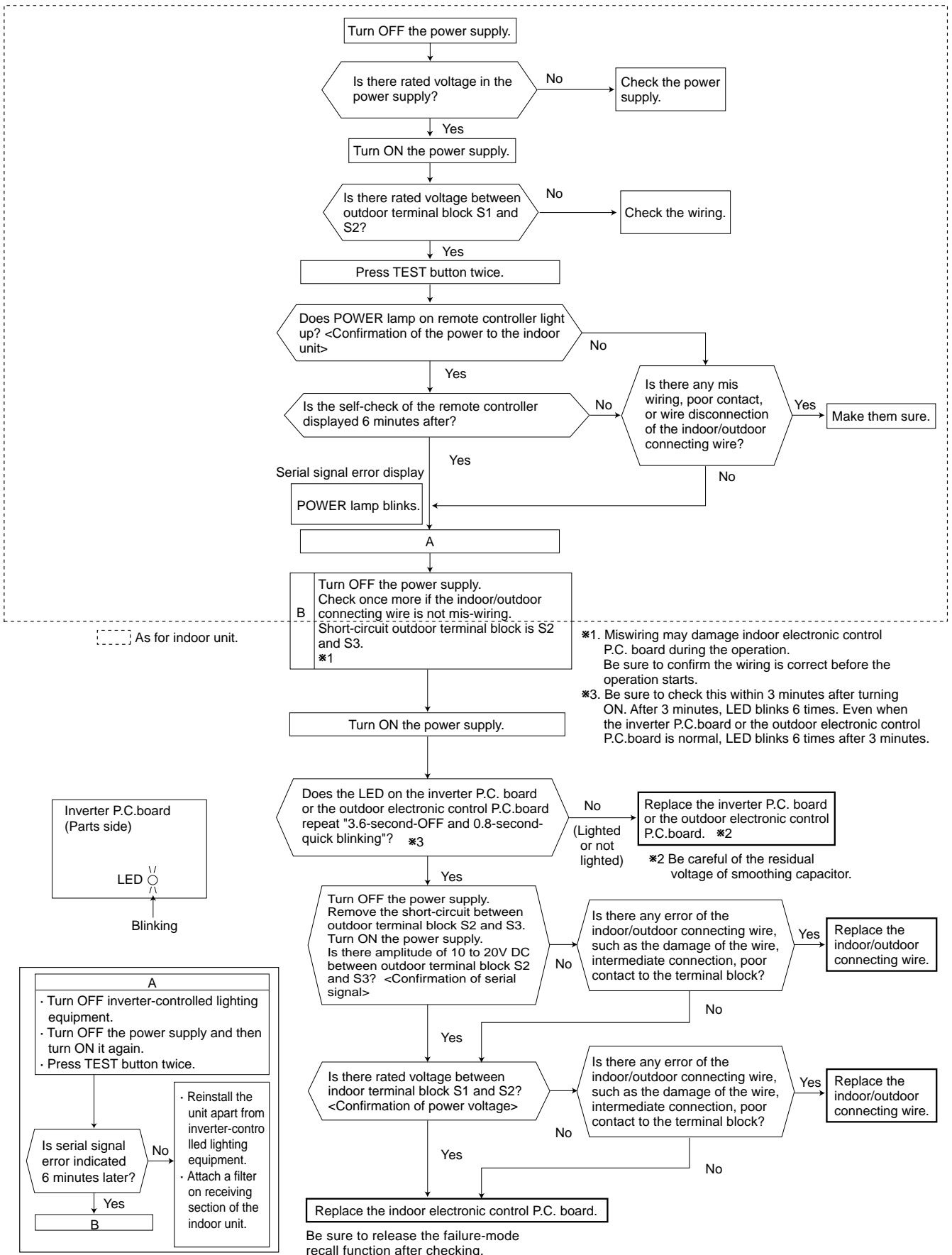

**Ⓟ Electromagnetic noise enters into TV sets or radios**

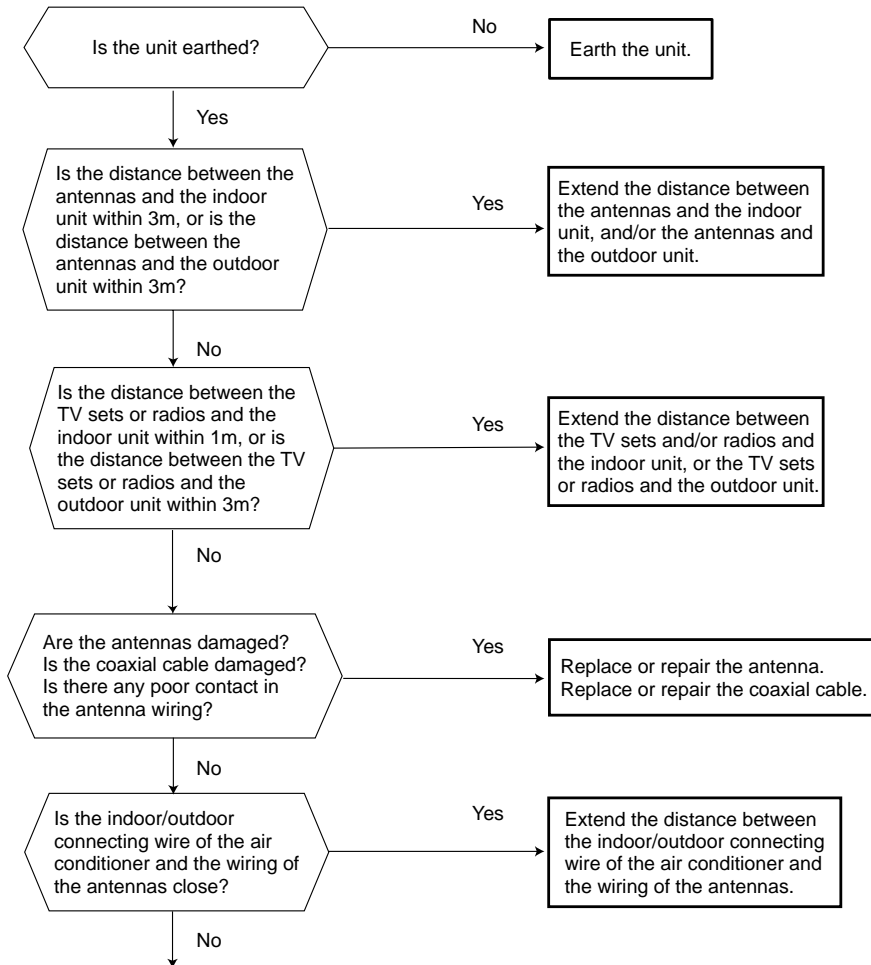

Even if all of the above conditions are fulfilled, the electromagnetic noise may enter, depending on the electric field strength or the installation condition (combination of specific conditions such as antennas or wiring).  
 Check the followings before asking for service.

- 1.Devices affected by the electromagnetic noise  
 TV sets, radios (FM/AM broadcast, shortwave)
- 2.Channel, frequency, broadcast station affected by the electromagnetic noise
- 3.Channel, frequency, broadcast station unaffected by the electromagnetic noise
- 4.Layout of ;  
 indoor/outdoor unit of the air conditioner, indoor/outdoor wiring, grounding wire, antennas, wiring from antennas, receiver
- 5.Electric field intensity of the broadcast station affected by the electromagnetic noise
- 6.Presence or absence of amplifier such as booster
- 7.Operation condition of air conditioner when the electromagnetic noise enters in.
  - 1)Turn OFF the power supply once, and then turn ON the power supply. In this situation check for the electromagnetic noise.
  - 2)Within 3 minutes after turning ON the power supply, press OPERATE/STOP (ON/OFF) button on the remote controller for power ON, and check for the electromagnetic noise.
  - 3)After a short time (3 minutes later after turning ON), the outdoor unit starts running. During operation, check for the electromagnetic noise.
  - 4)Press OPERATE/STOP (ON/OFF) button on the remote controller for power OFF, when the outdoor unit stops but the indoor/outdoor communication still runs on. In this situation check for the electromagnetic noise.

After checking the above, consult the service representative.



Outdoor unit does not operate. (LED display: display OFF)

[SUZ-KA50/60/71VA<sup>(1)</sup>.TH SUZ-KA60VAR2.TH]

**Q Check of power supply**

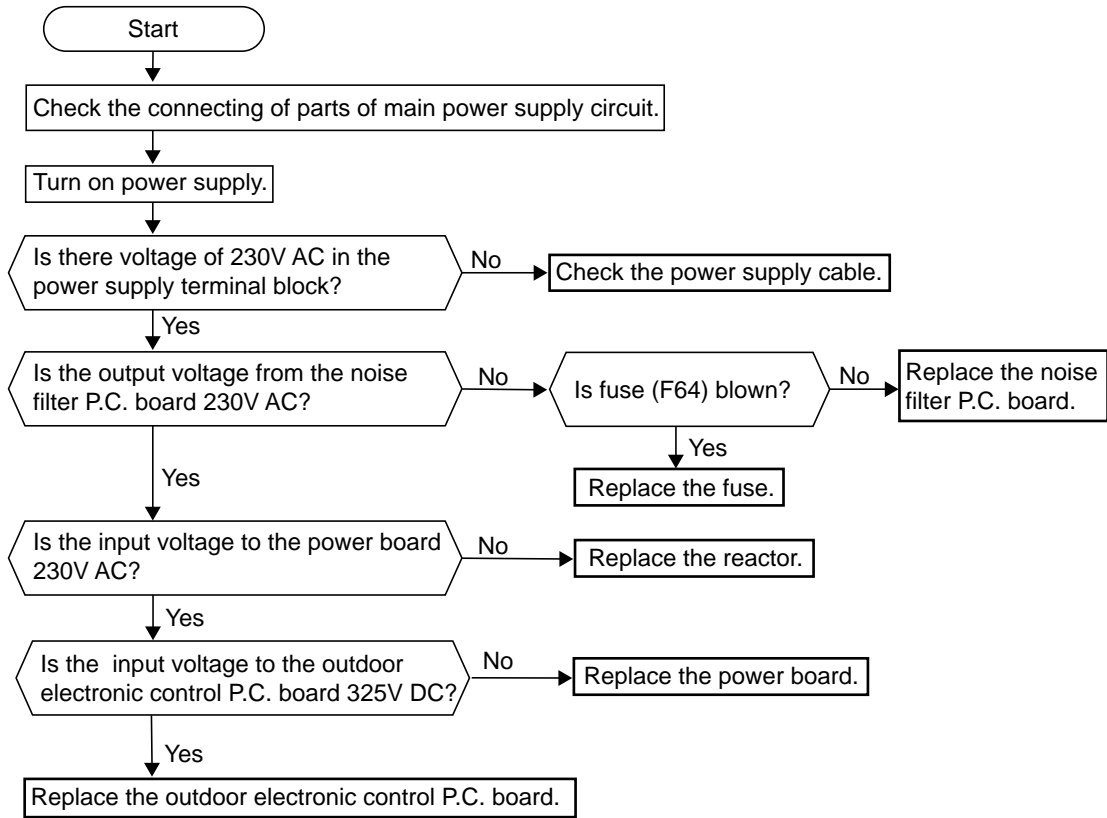

- When unit cannot operate neither by the remote controller nor by EMERGENCY OPERATION switch.  
Indoor unit does not operate.
- Outdoor unit does not operate.

**Ⓡ How to check miswiring and serial signal error (when outdoor unit does not work)**

(For wireless remote controller use model)

As for indoor unit.

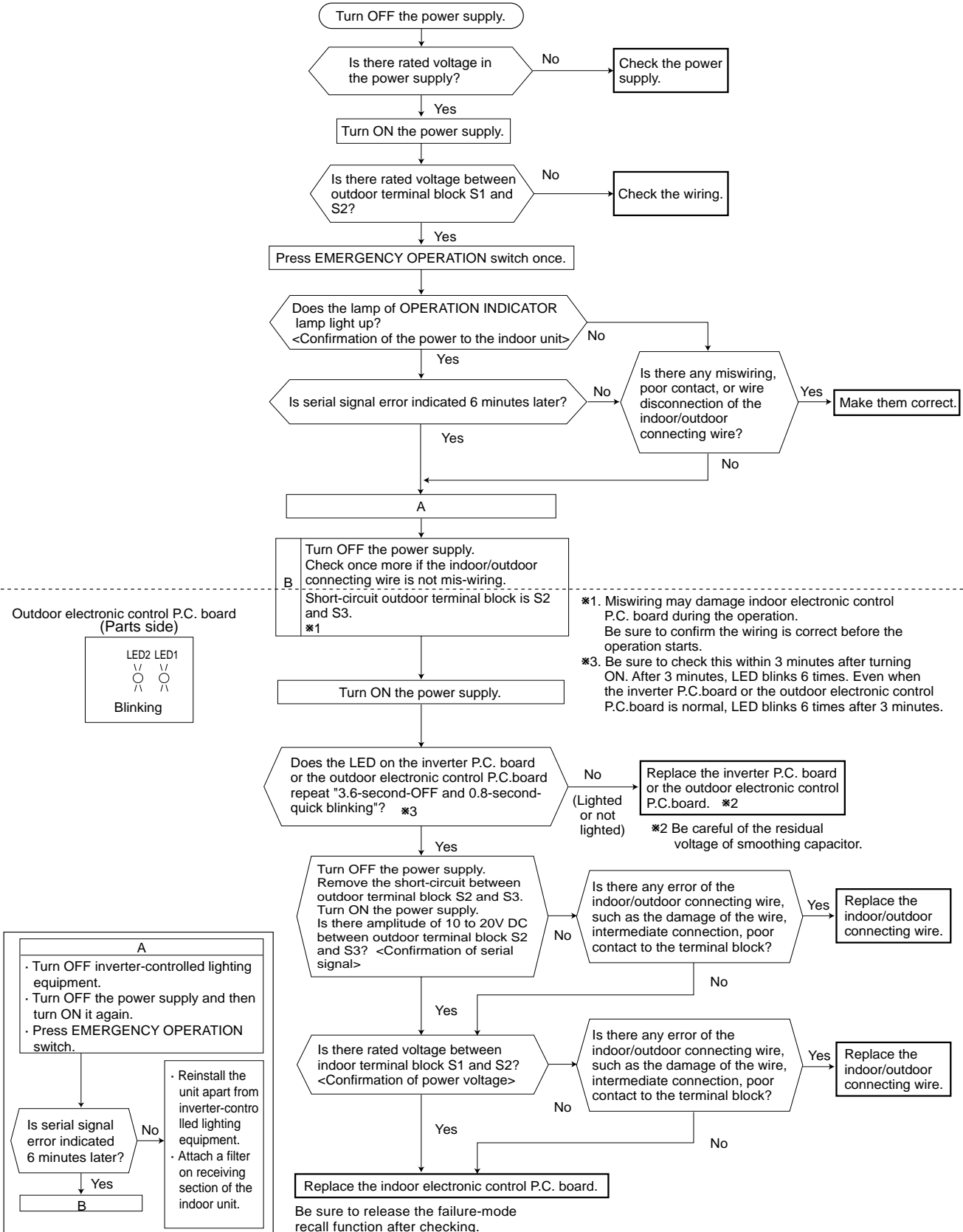

- When unit cannot operate neither by the remote controller.  
Indoor unit does not operate.
- Outdoor unit does not operate.

**Ⓡ How to check miswiring and serial signal error (when outdoor unit does not work)**

(For wired remote controller use model)

As for indoor unit.

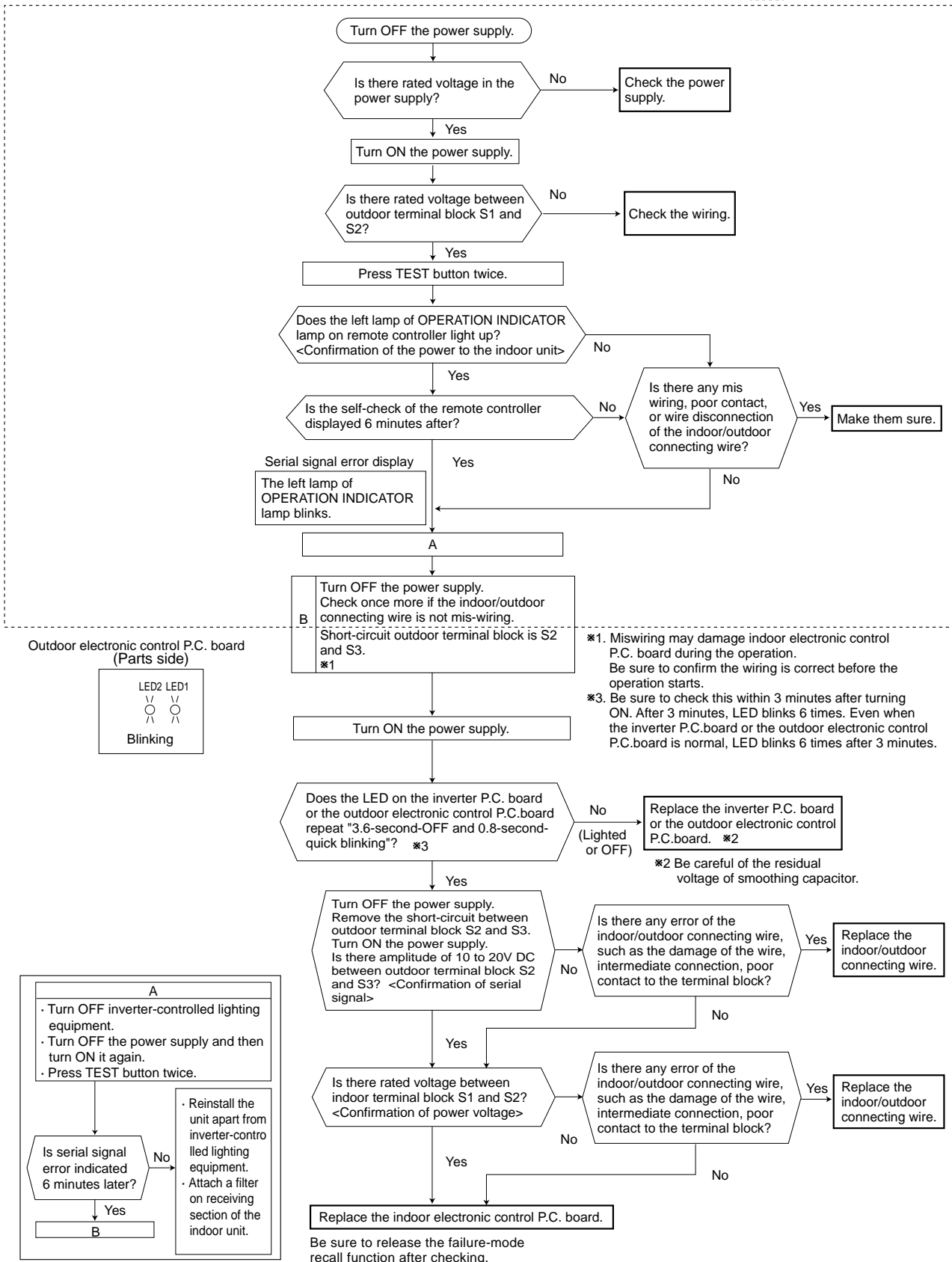

The cooling operation or heating operation does not operate. (LED display: Both LED1 and LED2 lighting)

**⑤ Check of R.V. coil**

**• When heating operation does not work.**

1. Disconnect the lead wire leading to the compressor.  
2. 3 minutes after turning on the power supply, start EMERGENCY OPERATION in HEAT mode.

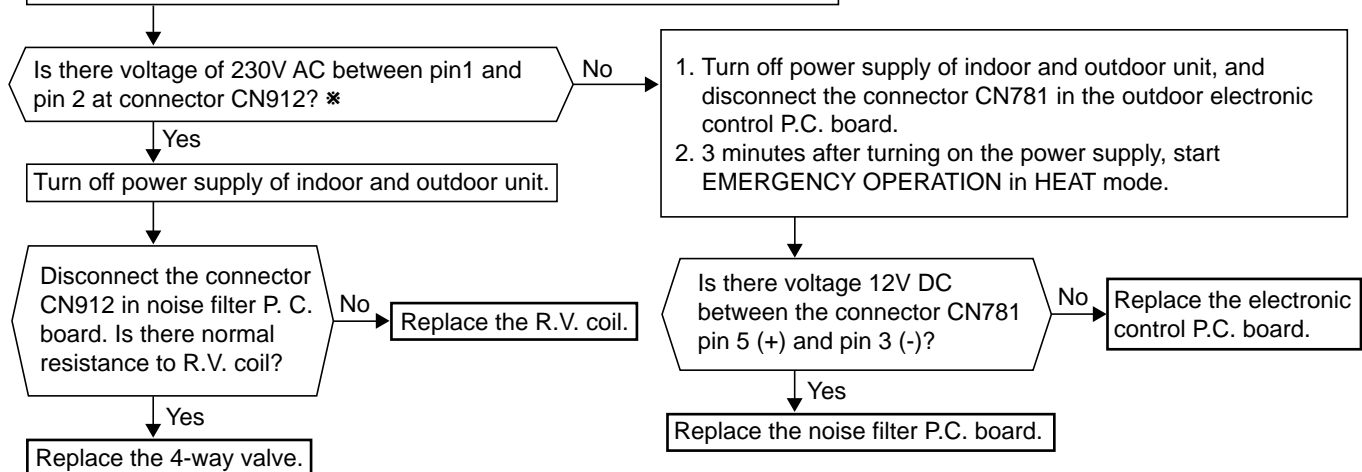

**• When cooling operation does not work.**

1. Disconnect the lead wire leading to the compressor.  
2. 3 minutes after turning on the power supply, start EMERGENCY OPERATION in COOL mode.

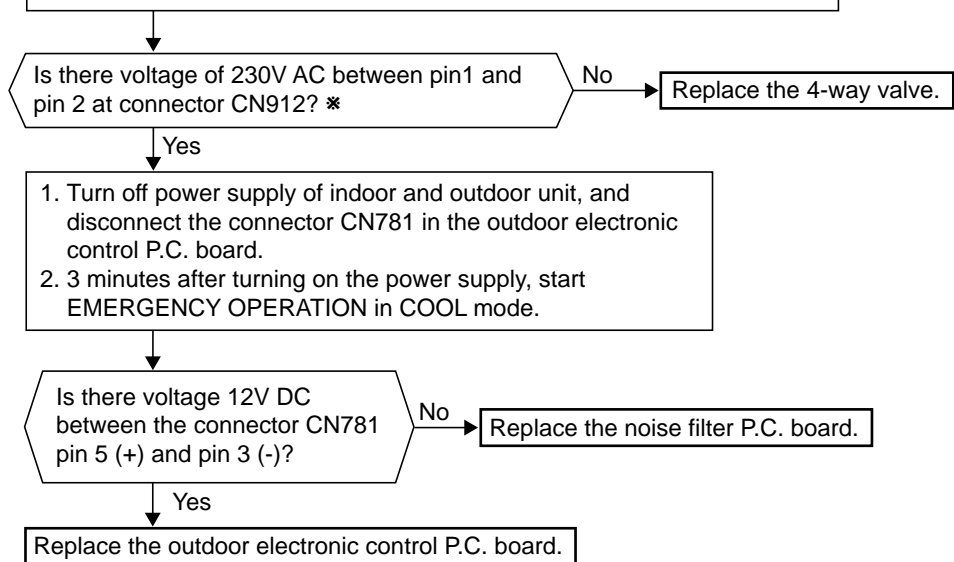

\* If the connector CN912 is not connected or R.V. coil is open, voltage occurs between terminals even when the control is OFF.

- When cooling, heat exchanger of non-operating indoor unit frosts.
- When heating, non-operating indoor unit get warm.

**T Check of LEV**

LED display:

LED1	LED2
Lighting	Lighting
6 time	Goes out

Turn on power supply to the outdoor unit after checking LEV coil is mounted to the LEV body securely.

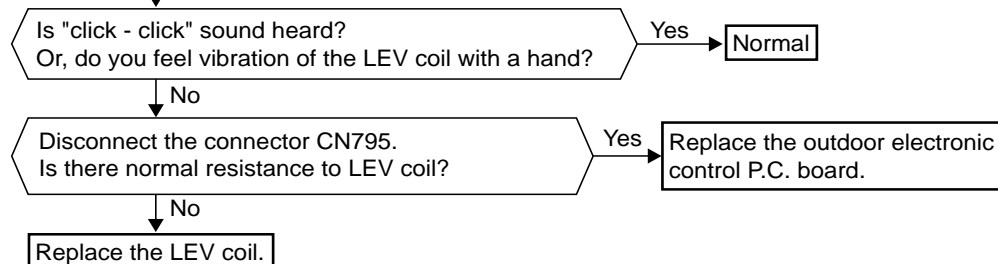

- When heating, room does not get warm.
- When cooling, room does not get cool.

**U How to check inverter/ compressor**

LED display:

LED1	LED2
Lighting	Lighting
Lighting	Twice
Twice	Goes out

Disconnect the terminal of the compressor. 3 minutes after turning on the power supply, start EMERGENCY OPERATION.

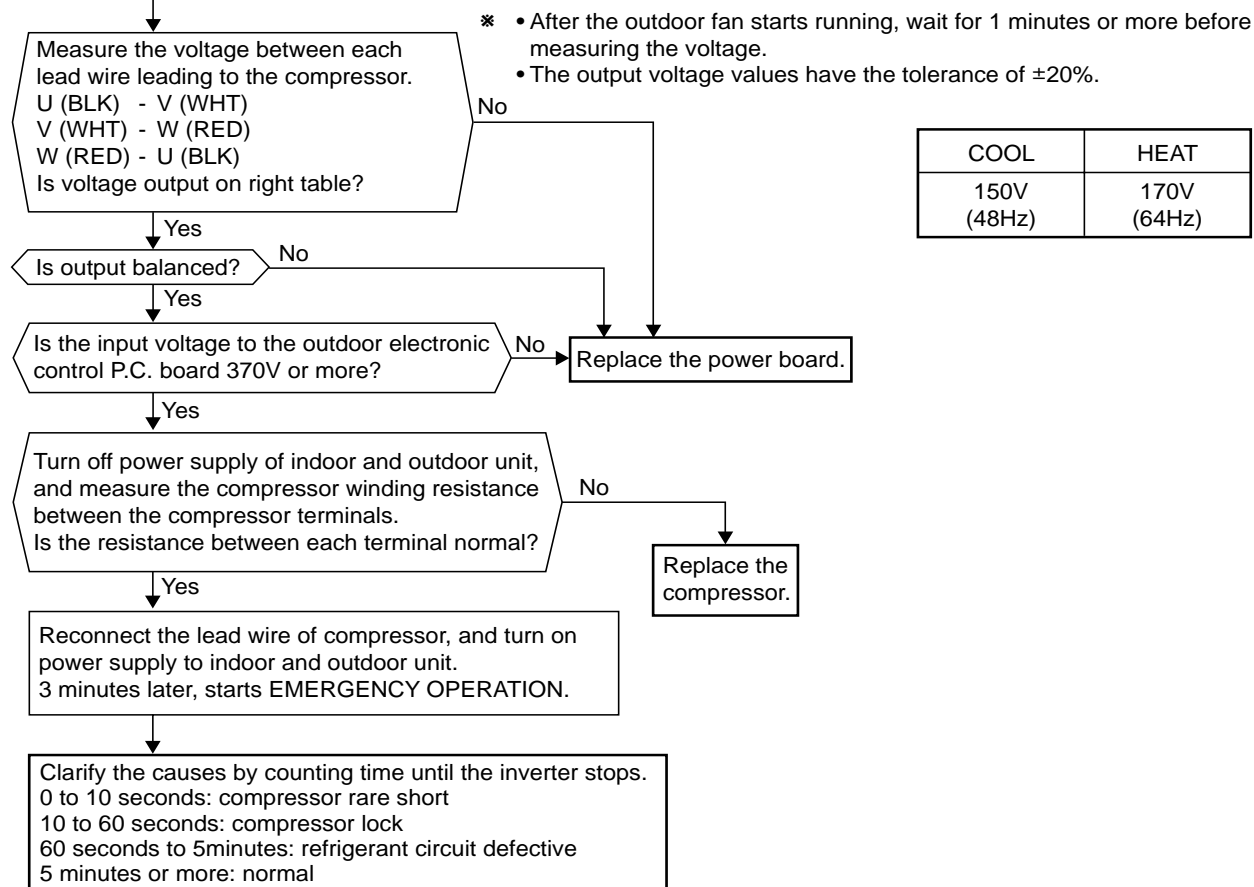

• When thermistor is abnormal.

[SUZ-KA50/60/71VA<sub>(1)</sub>.TH SUZ-KA60VAR2.TH]

**Ⓥ Check of outdoor thermistors**

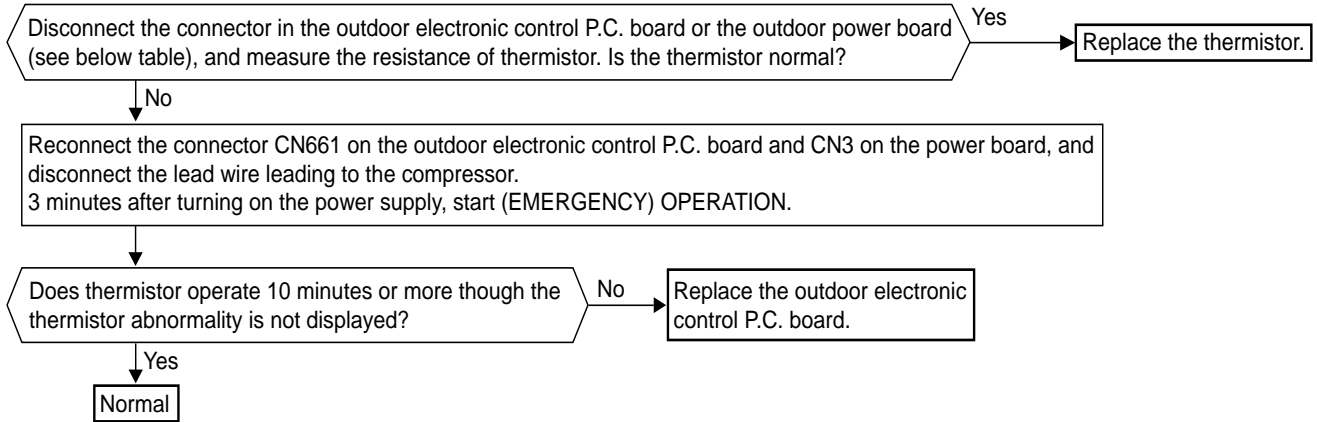

Thermistor	Symbol	Connector, Pin No.
Defrost thermistor	RT61	Between CN661 pin1 and pin2 on the outdoor electronic control P.C. board
Discharge temperature thermistor	RT62	Between CN661 pin3 and pin4 on the outdoor electronic control P.C. board
Outdoor heat exchanger temperature thermistor	RT68	Between CN661 pin7 and pin8 on the outdoor electronic control P.C. board
Fin temperature thermistor	RT64	Between CN3 pin1 and pin2 on the outdoor power board
Ambient temperature thermistor	RT65	Between CN663 pin1 and pin2 on the outdoor electronic control P.C. board

• Fan motor does not operate or stops operating shortly after starting the operation.

**Ⓦ Check of outdoor fan motor**

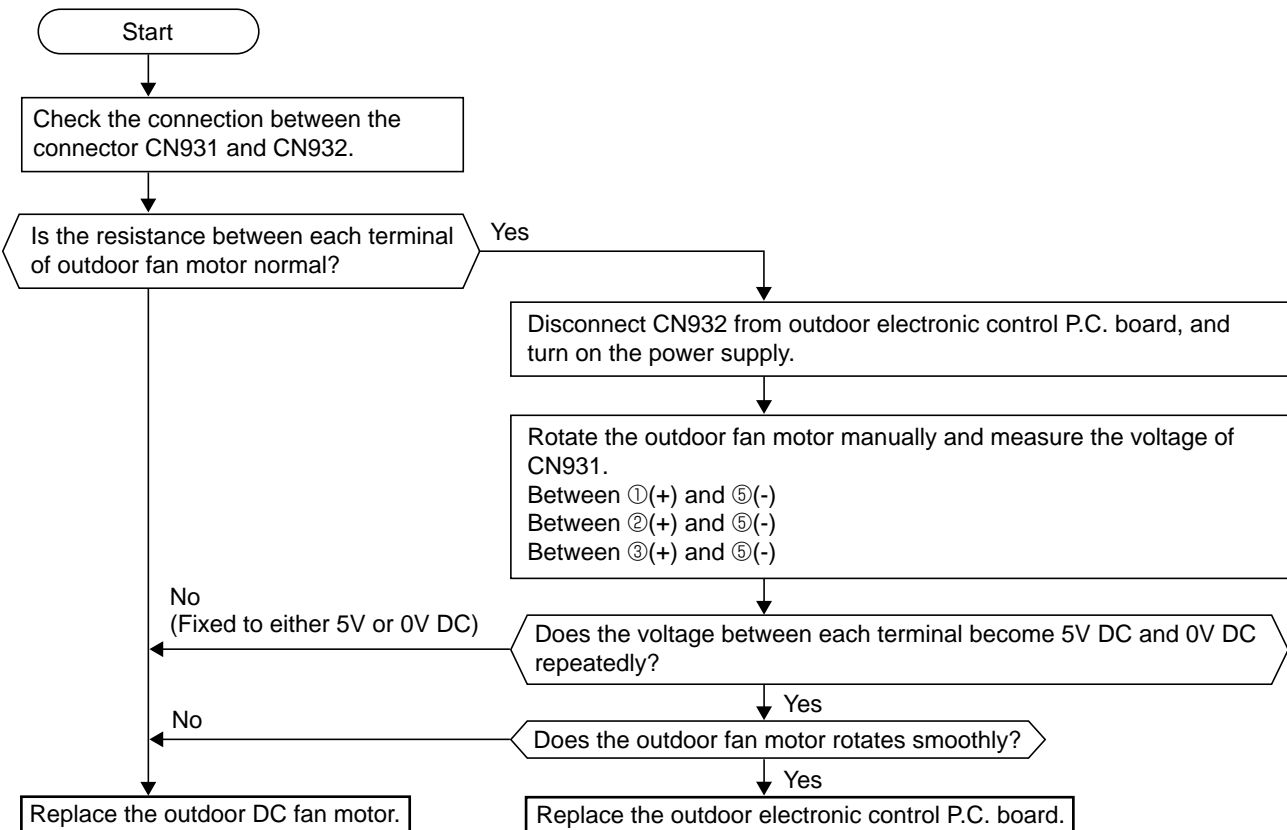

• When the operation frequency does not go up from lowest frequency.

**⊗ Check of HPS**

SUZ-KA60VAR2.TH  
SUZ-KA71VA<sup>(1)</sup>.TH

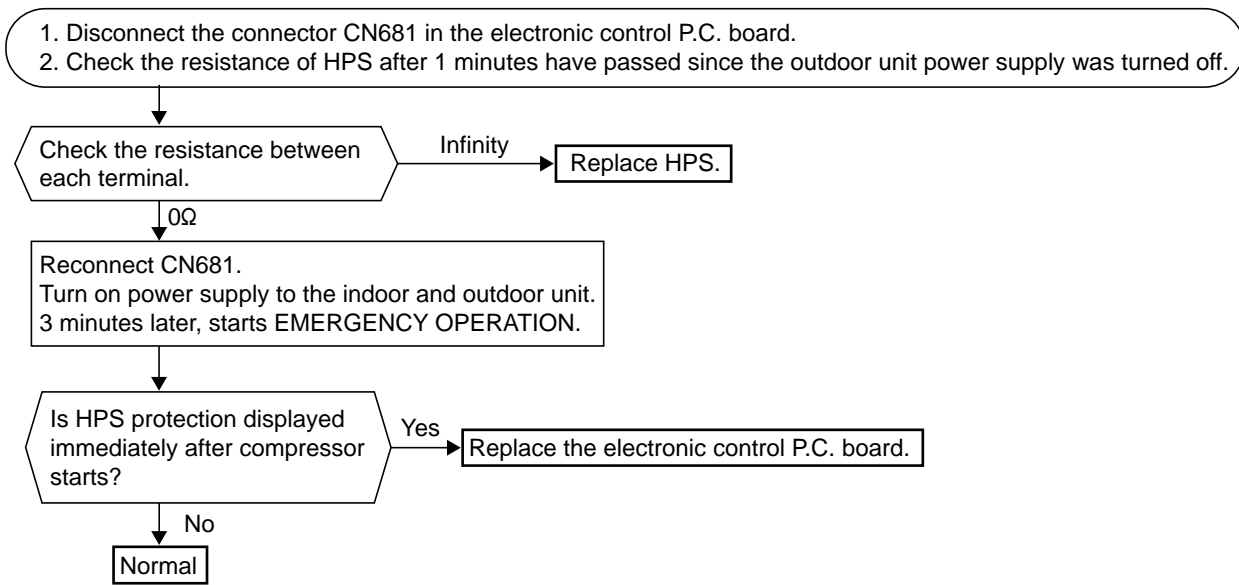

• Outdoor unit does not operate at all, or stops immediately due to overcurrent.

**⊙ Check of current-limiting resistor**

When the current-limiting resistor is open, the rush current limiting relay (X64) may not work properly.

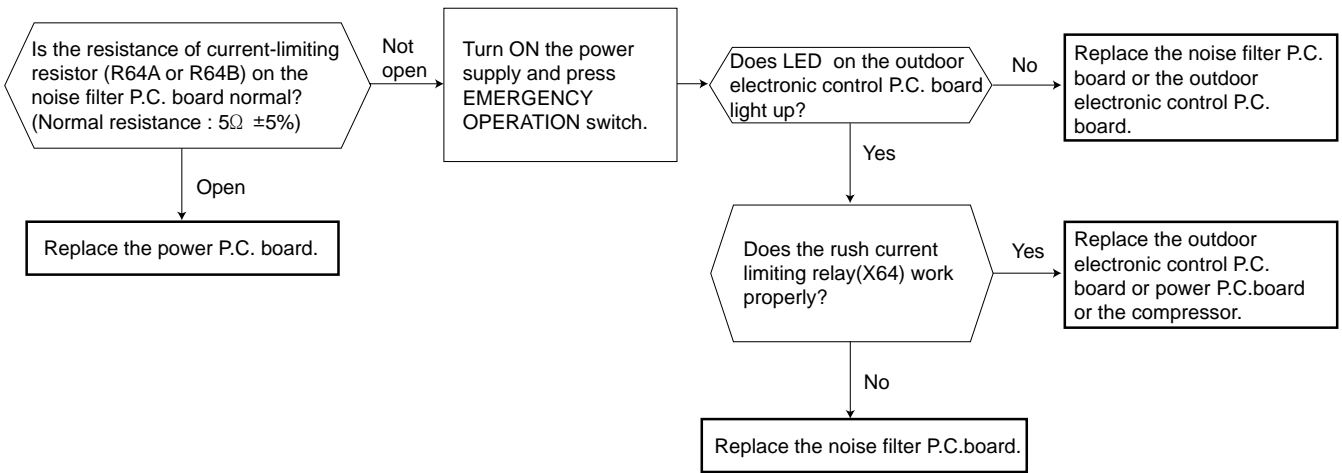

**a How to check inverter/compressor**

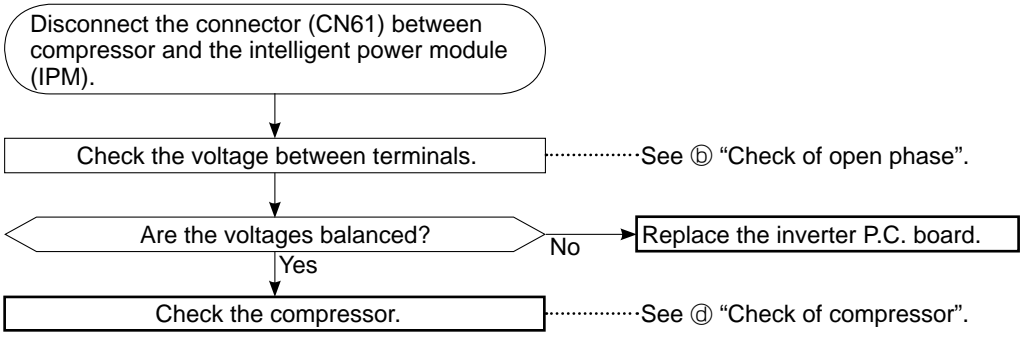

**b Check of open phase**

- With the connector between the compressor and the intelligent power module disconnected, activate the inverter and check if the inverter is normal by measuring the balance of voltage between the terminals.

The output voltage values have the tolerance of ± 20%.

<< Operation method>>

Start cooling or heating operation by pressing EMERGENCY OPERATION switch on the indoor unit. (TEST RUN OPERATION : Refer to page 31 for SLZ/SUZ and page 37 for SEZ/SUZ.)

<<Measurement point>>

- At 3 points
- BLK (U) - WHT (V)
- BLK (U) - RED (W)
- WHT (V) - RED (W)

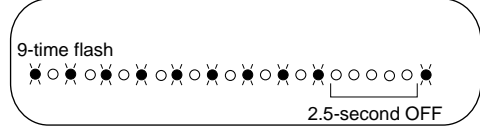

- NOTE:**
1. Output voltage varies according to power supply voltage.
  2. Measure the voltage by analog type tester.
  3. During this check, LED of the inverter P.C. board flashes 9 times. (Refer to 12-6-3. (KA25/35VA) or 12-6-7.)

**d Check of compressor**

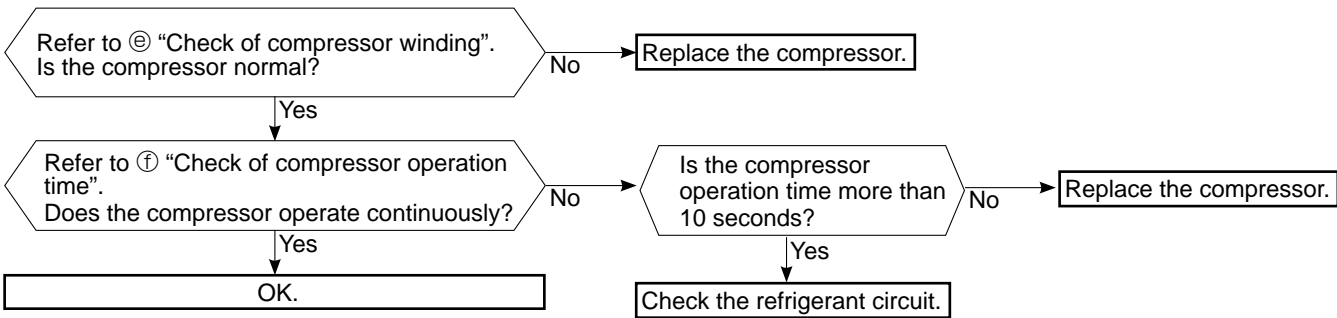



**e Check of compressor winding**

- Disconnect the connector (CN61) between the compressor and intelligent power module, and measure the resistance between the compressor terminals.
- <<Measurement point>>  
 at 3 points  
 BLK-WHT  
 BLK-RED      \* Measure the resistance between the lead wires at 3 points.  
 WHT-RED
- <<Judgement>>  
 Refer to 12-4.  
 0 [Ω] .....Abnormal [short]  
 Infinite [Ω] .....Abnormal [open]
- NOTE:** Be sure to zero the ohmmeter before measurement.

**f Check of compressor operation time**

- Connect the compressor and activate the inverter. Then measure the time until the inverter stops due to over current.
- <<Operation method>>  
 Start heating or cooling operation by pressing EMERGENCY OPERATION switch on the indoor unit.  
 (TEST RUN OPERATION : Refer to page 31 for SLZ/SUZ and page 37 SEZ/SUZ.)
- <<Measurement>>  
 Measure the time from the start of compressor to the stop of compressor due to overcurrent.

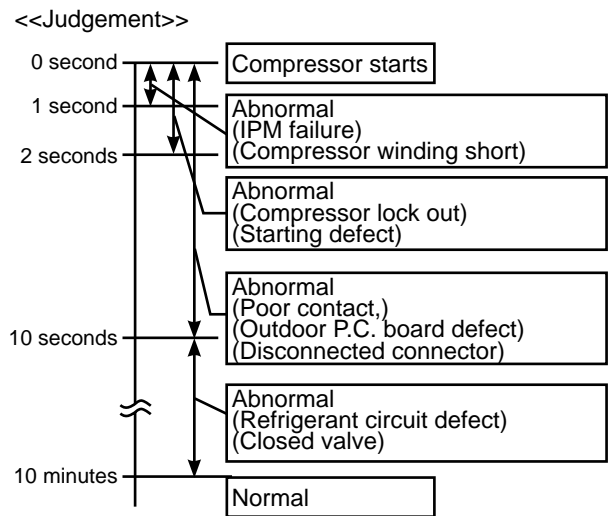

**g Check of outdoor thermistors**

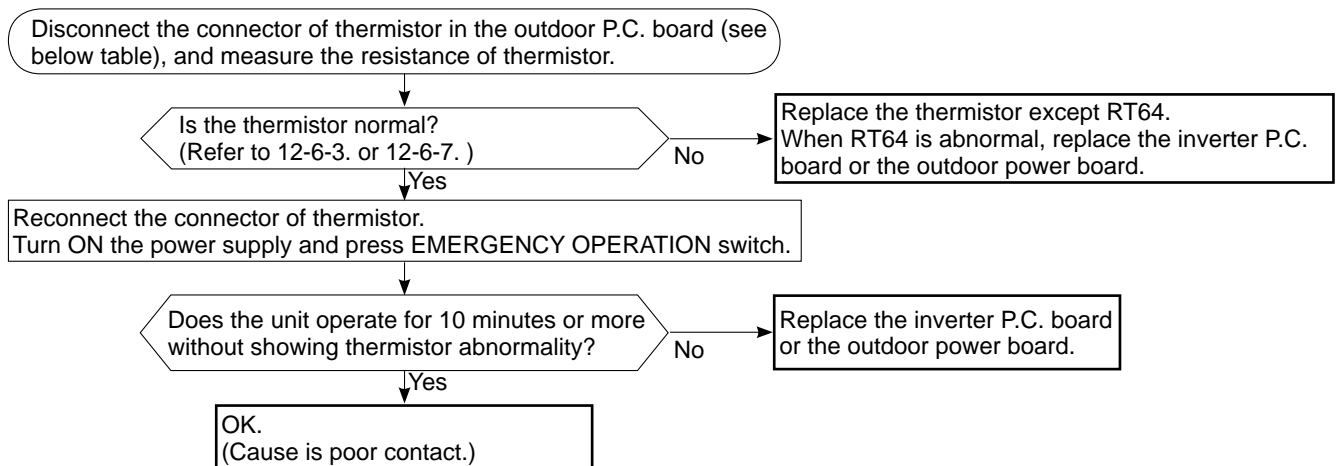

Thermistor	Symbol	Connector, Pin No.	Board
Defrost	RT61	Between CN641 pin1 and pin2	Inverter P.C. board
Discharge temperature	RT62	Between CN641 pin3 and pin4	
Fin temperature	RT64	Between CN642 pin1 and pin2	
Ambient temperature	RT65	Between CN643 pin1 and pin2	
Outdoor heat exchanger temperature	RT68	Between CN644 pin1 and pin3	

**h Check of R.V. coil**

- ※ First of all, measure the resistance of R.V. coil to check if the coil is defective. Refer to 12-4.
- ※ In case CN721 is not connected or R.V. coil is open, voltage is generated between the terminal pins of the connector although any signal is not being transmitted to R.V. coil.  
Check if CN721 is connected.

**Unit operates COOL mode even if it is set to HEAT mode.**

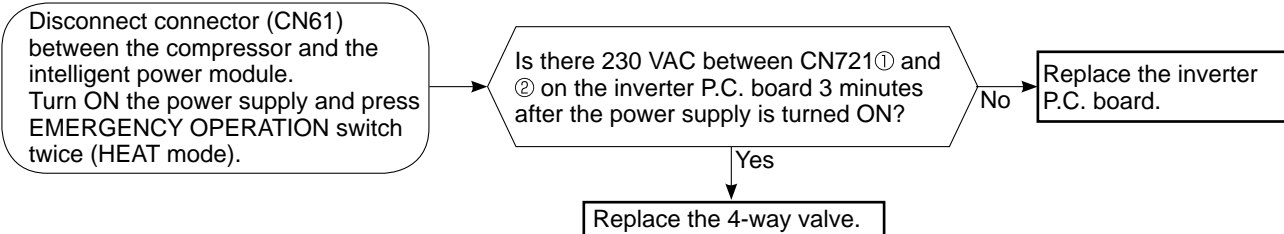

**Unit operates HEAT mode even if it is set to COOL mode.**

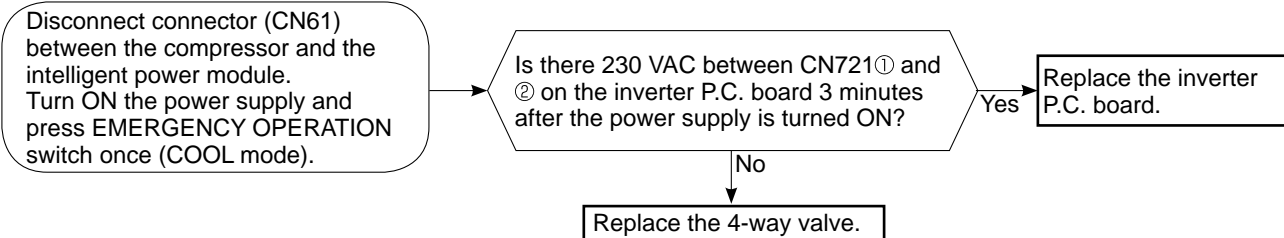

**i Check of outdoor fan motor**

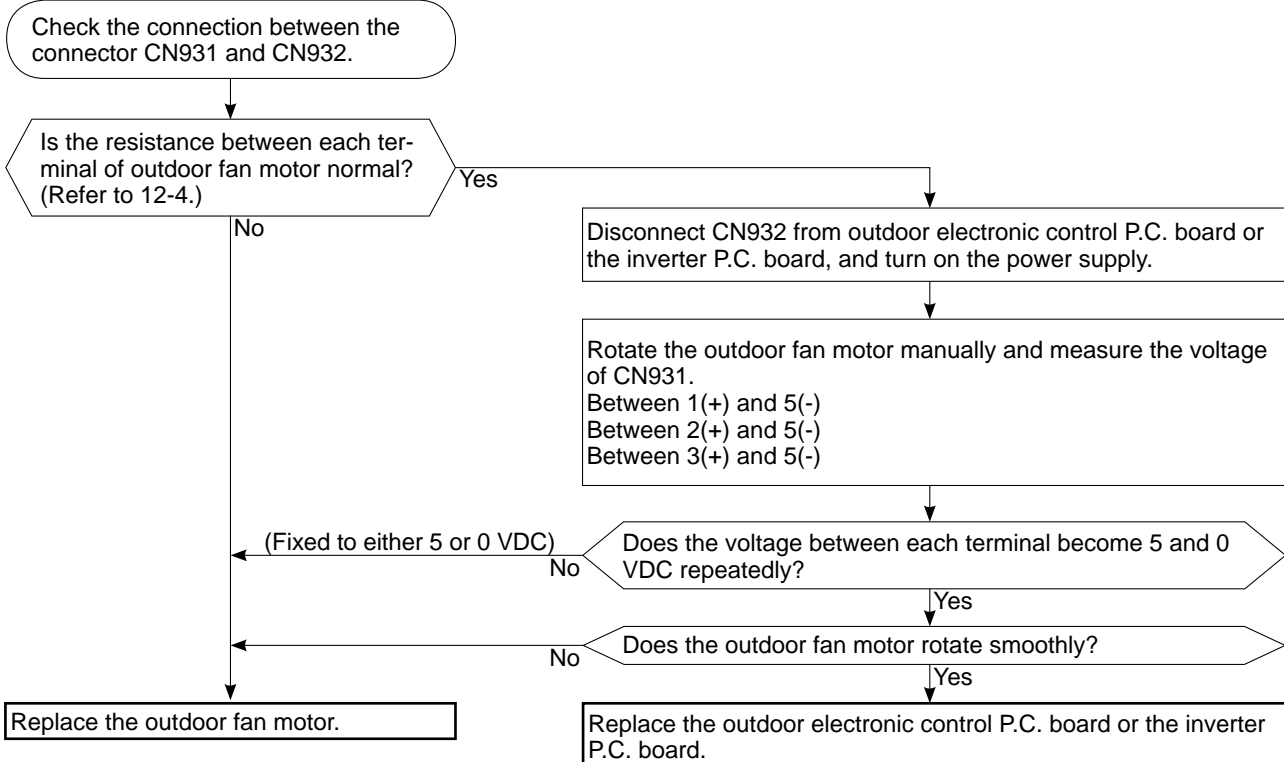

**① Check of power supply**

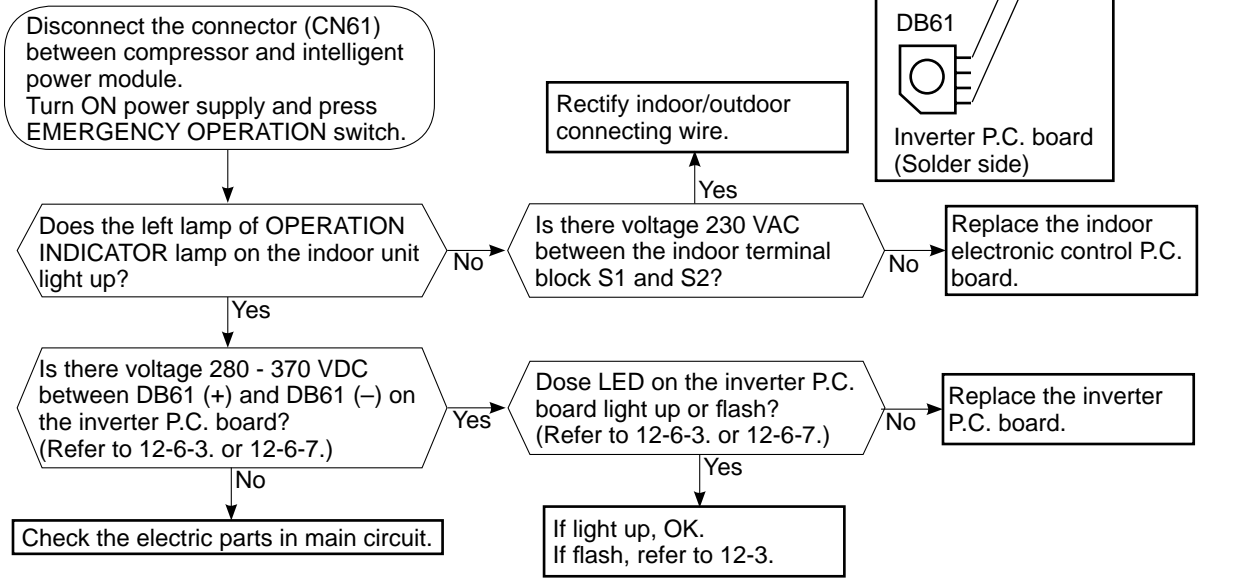

**② Check of LEV** (For wireless remote controller use model)

Turn ON the power supply.  
<Preparation of the remote controller>  
① While pressing both OPERATION SELECT button and TOO COOL button on the remote controller at the same time, press RESET button.  
② First, release RESET button.  
And release the other two buttons after all LCD except the set temperature in operation display section of the remote controller is displayed after 3 seconds.



Press OPERATE/STOP (ON/OFF) button of the remote controller (the set temperature is displayed) with the remote controller headed towards the indoor unit. \*1  
Expansion valve operates in full-opening direction.

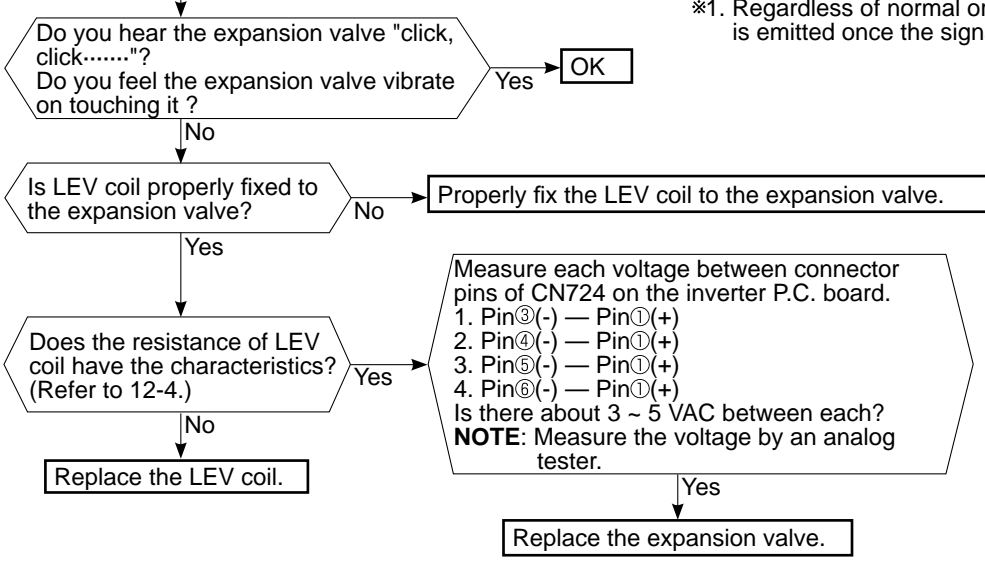
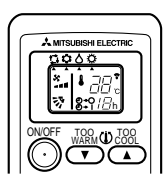

\*1. Regardless of normal or abnormal condition, a short beep is emitted once the signal is received.

**NOTE :** After check of LEV, do the undermentioned operations.  
1. Turn OFF the power supply and turn ON it again.  
2. Press RESET button on the remote controller.

**m Check of LEV (Expansion valve)** (For wired remote controller use model)

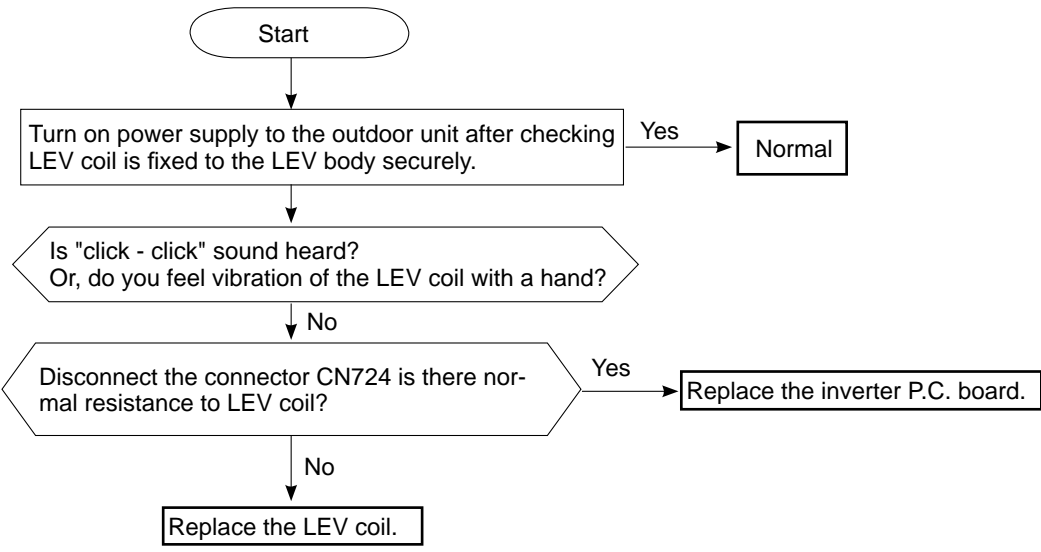

**n Check of inverter P.C. board**

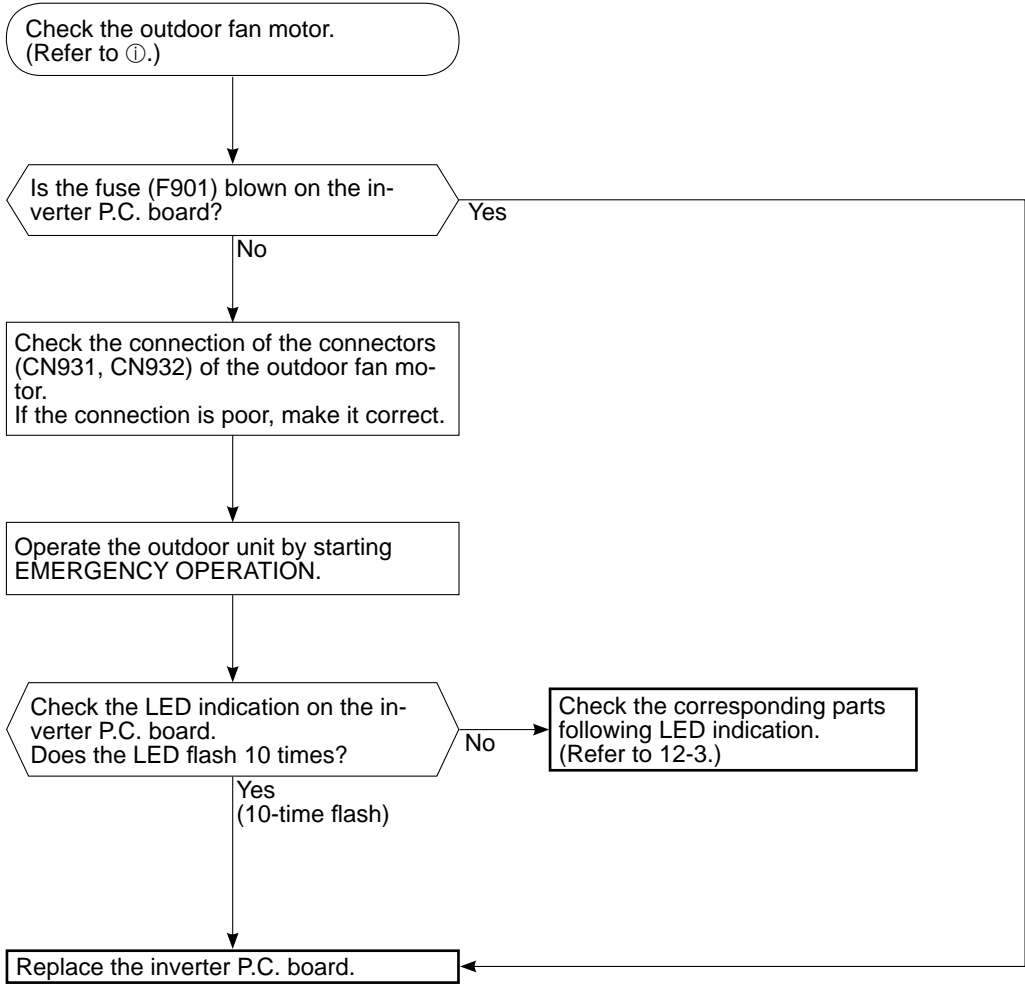

**P How to check miswiring and serial signal error**

(For wireless remote controller use model)

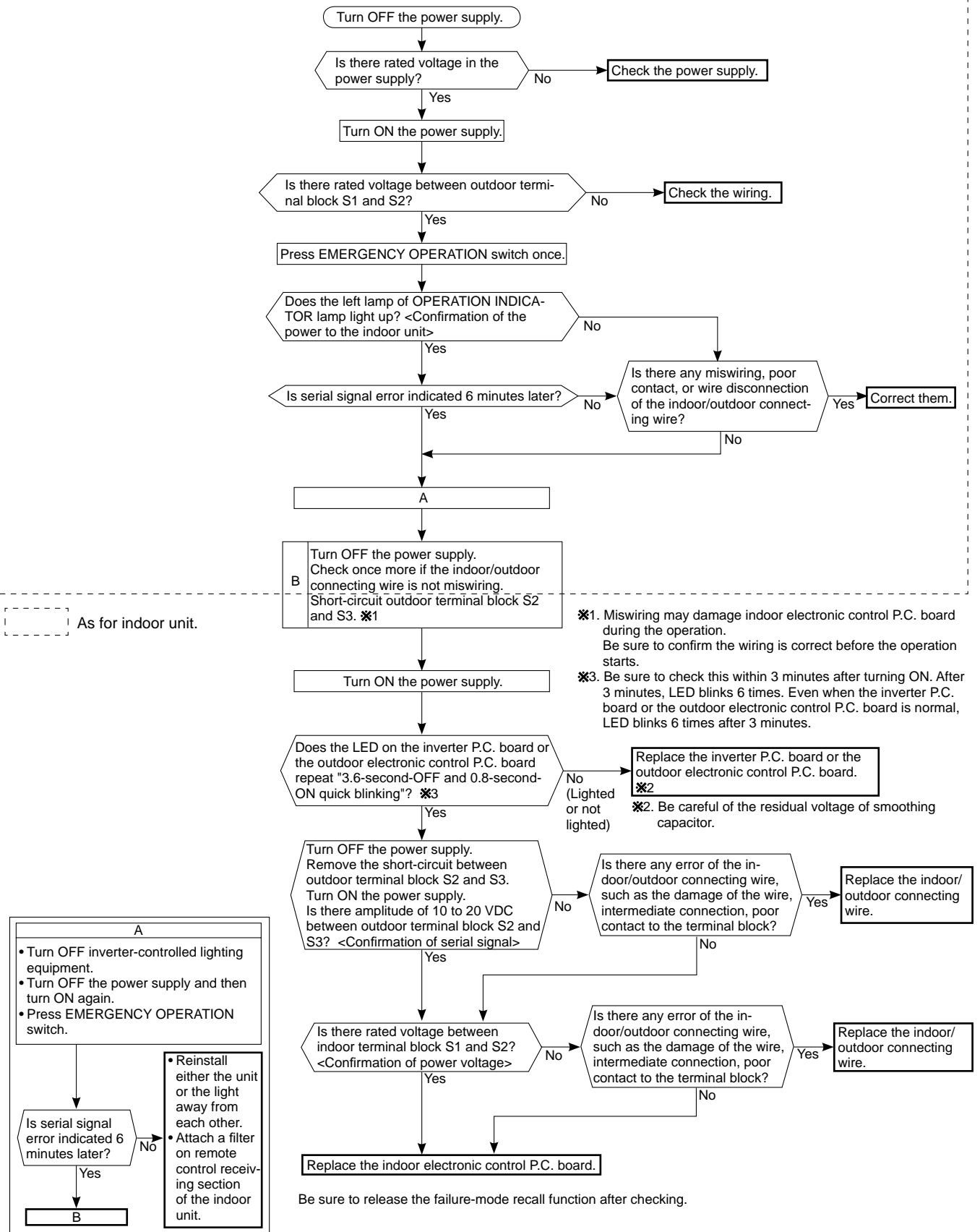

**Q How to check miswiring and serial signal error**

(For wired remote controller use model)

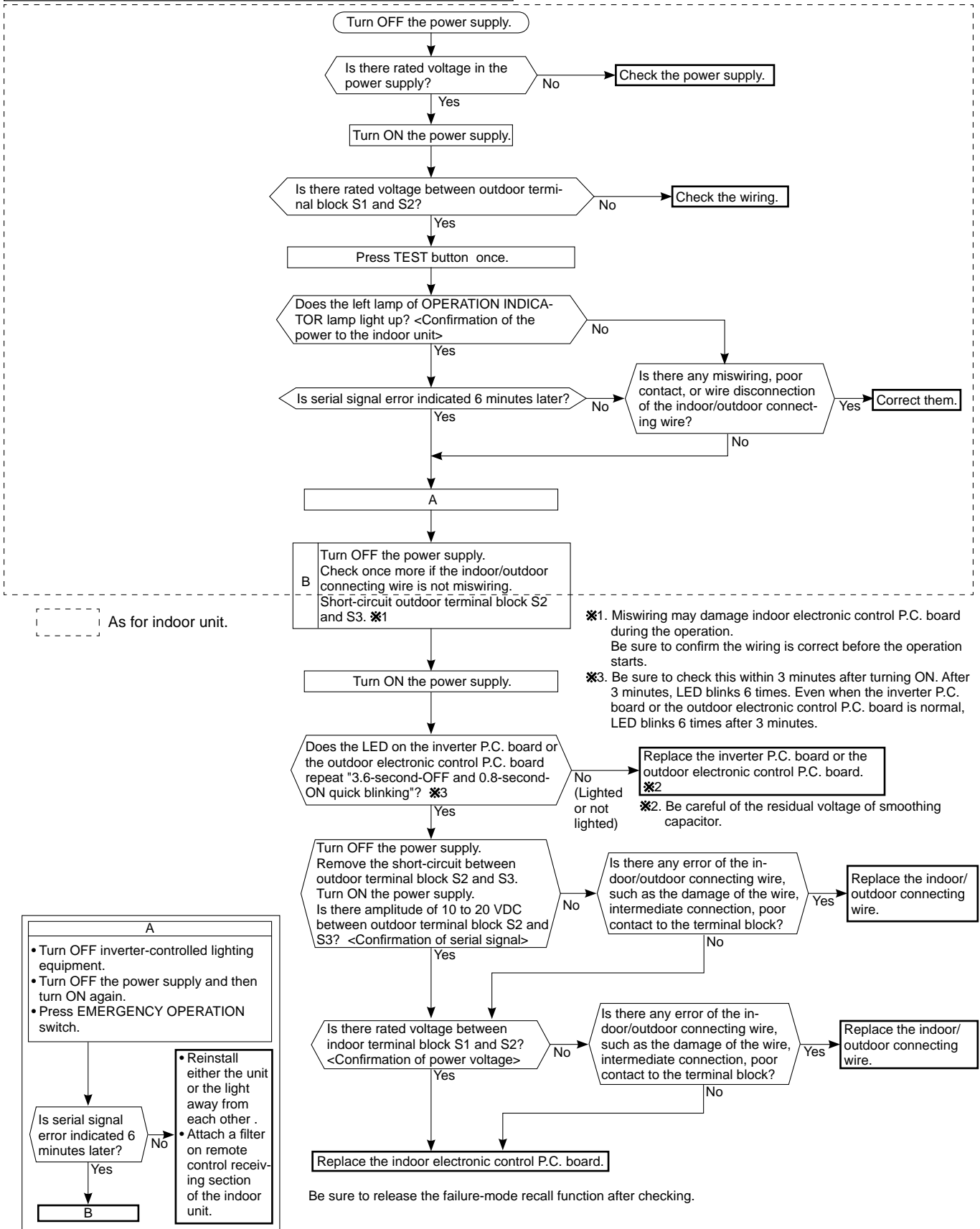

**Ⓡ Electromagnetic noise enters into TV sets or radios**

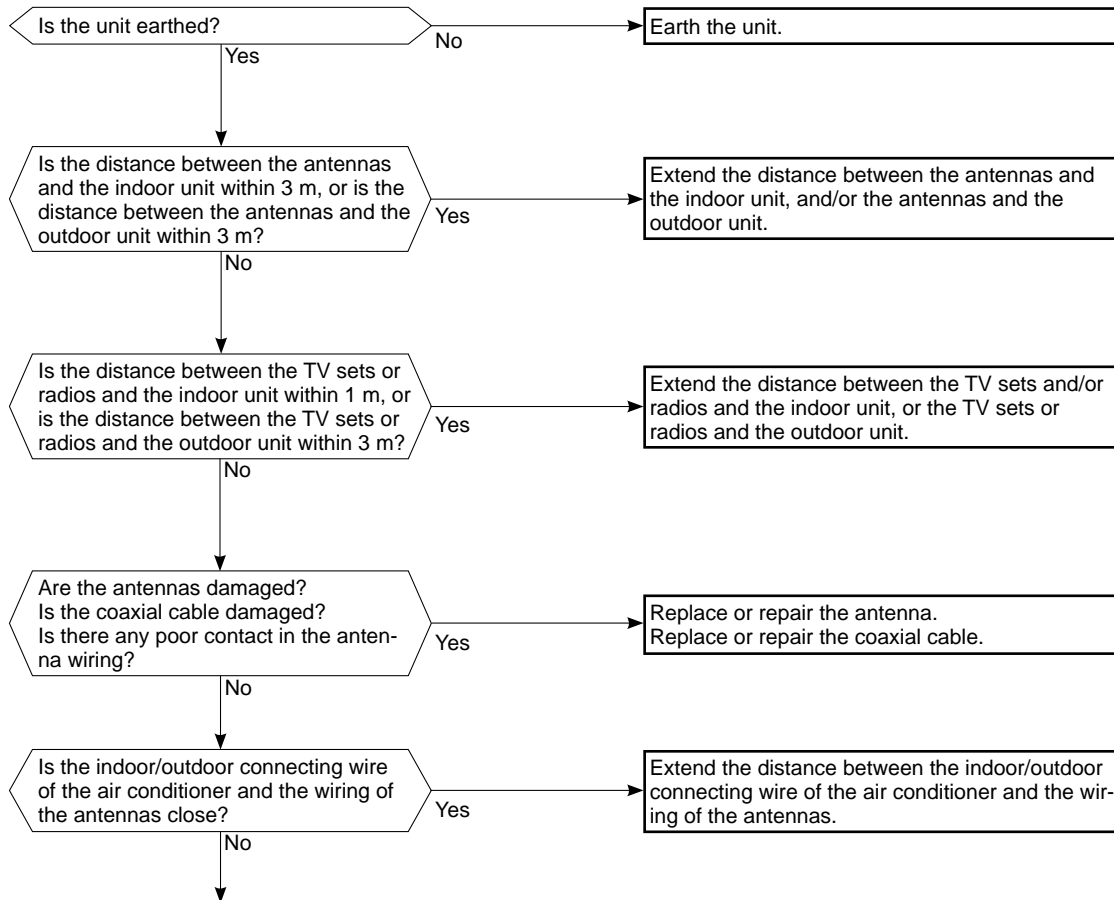

Even if all of the above conditions are fulfilled, the electromagnetic noise may enter, depending on the electric field strength or the installation condition (combination of specific conditions such as antennas or wiring). Check the following before asking for service.

1. Devices affected by the electromagnetic noise  
TV sets, radios (FM/AM broadcast, shortwave)
2. Channel, frequency, broadcast station affected by the electromagnetic noise
3. Channel, frequency, broadcast station unaffected by the electromagnetic noise
4. Layout of ;  
indoor/outdoor unit of the air conditioner, indoor/outdoor wiring, earth wire, antennas, wiring from antennas, receiver
5. Electric field intensity of the broadcast station affected by the electromagnetic noise
6. Presence or absence of amplifier such as booster
7. Operation condition of air conditioner when the electromagnetic noise enters in
  - 1) Turn OFF the power supply once, and then turn ON the power supply. In this situation, check for the electromagnetic noise.
  - 2) Within 3 minutes after turning ON the power supply, press OPERATE/STOP (ON/OFF) button on the remote controller for power ON, and check for the electromagnetic noise.
  - 3) After a short time (3 minutes later after turning ON), the outdoor unit starts running. During operation, check for the electromagnetic noise.
  - 4) Press OPERATE/STOP (ON/OFF) button on the remote controller for power OFF, when the outdoor unit stops but the indoor/outdoor communication still runs on. In this situation, check for the electromagnetic noise.

## 12-6. Test point diagram and voltage

### 12-6-1. Inverter P.C. board

SUZ-KA25VA.TH

SUZ-KA35VA.TH

SUZ-KA25VAH.TH

SUZ-KA35VAH.TH

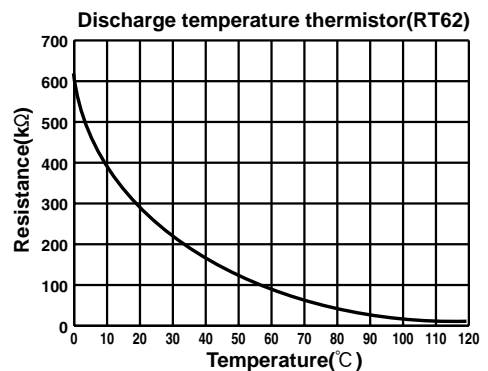
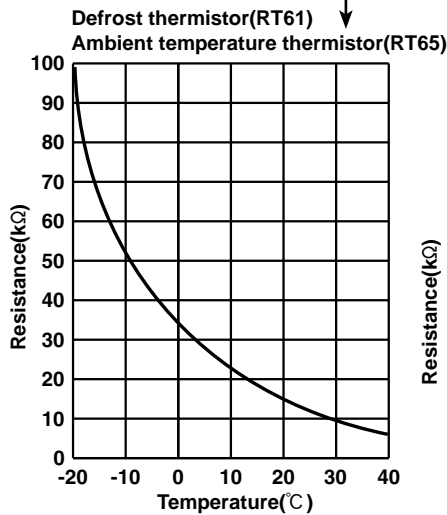
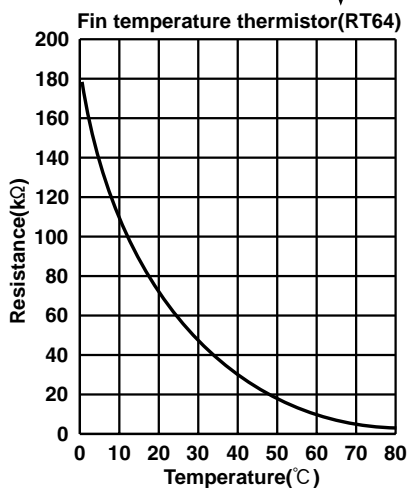
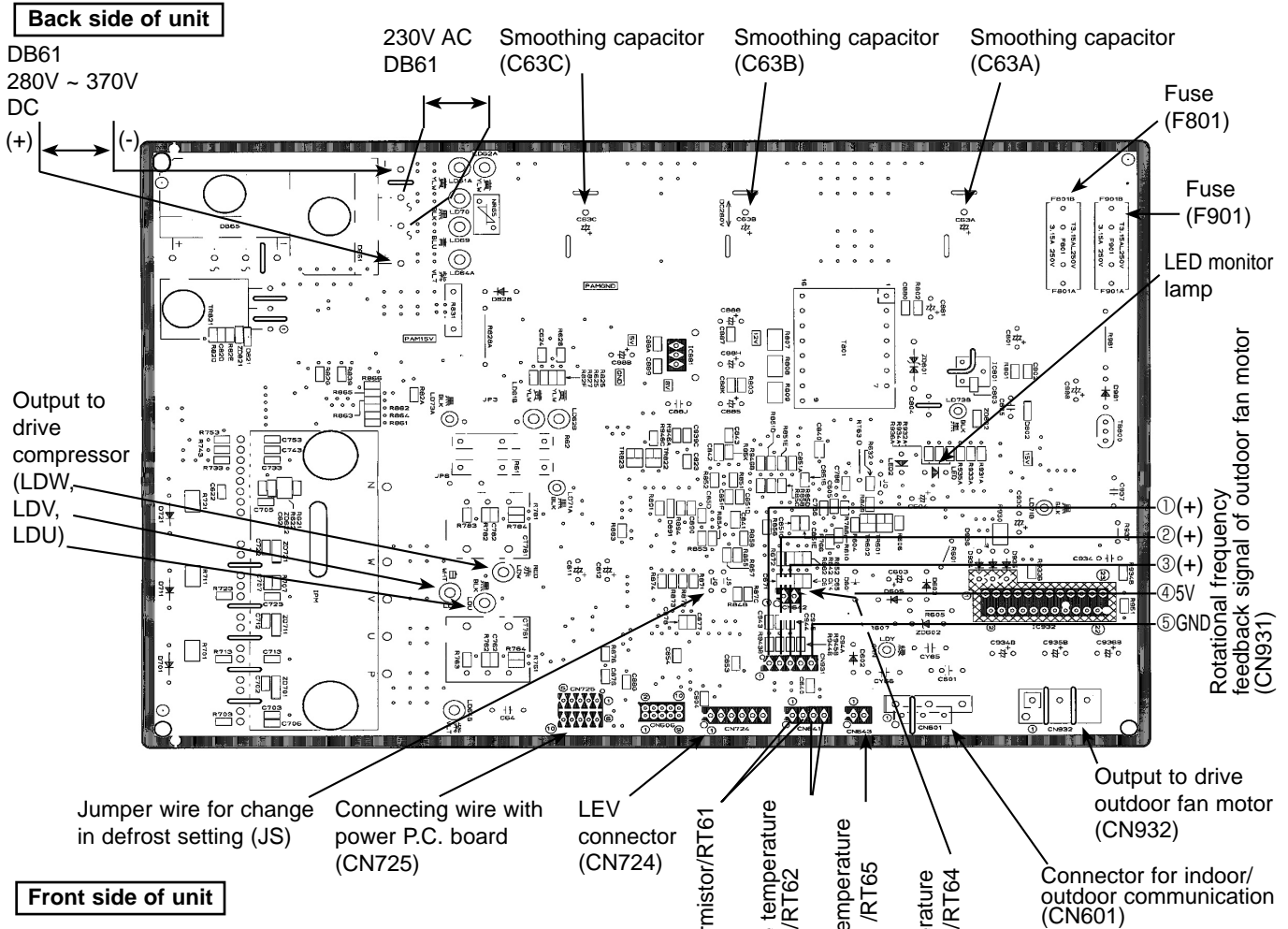



12-6-2. Power P.C. board  
 SUZ-KA25VA.TH SUZ-KA35VA.TH  
 SUZ-KA25VAH.TH SUZ-KA35VAH.TH

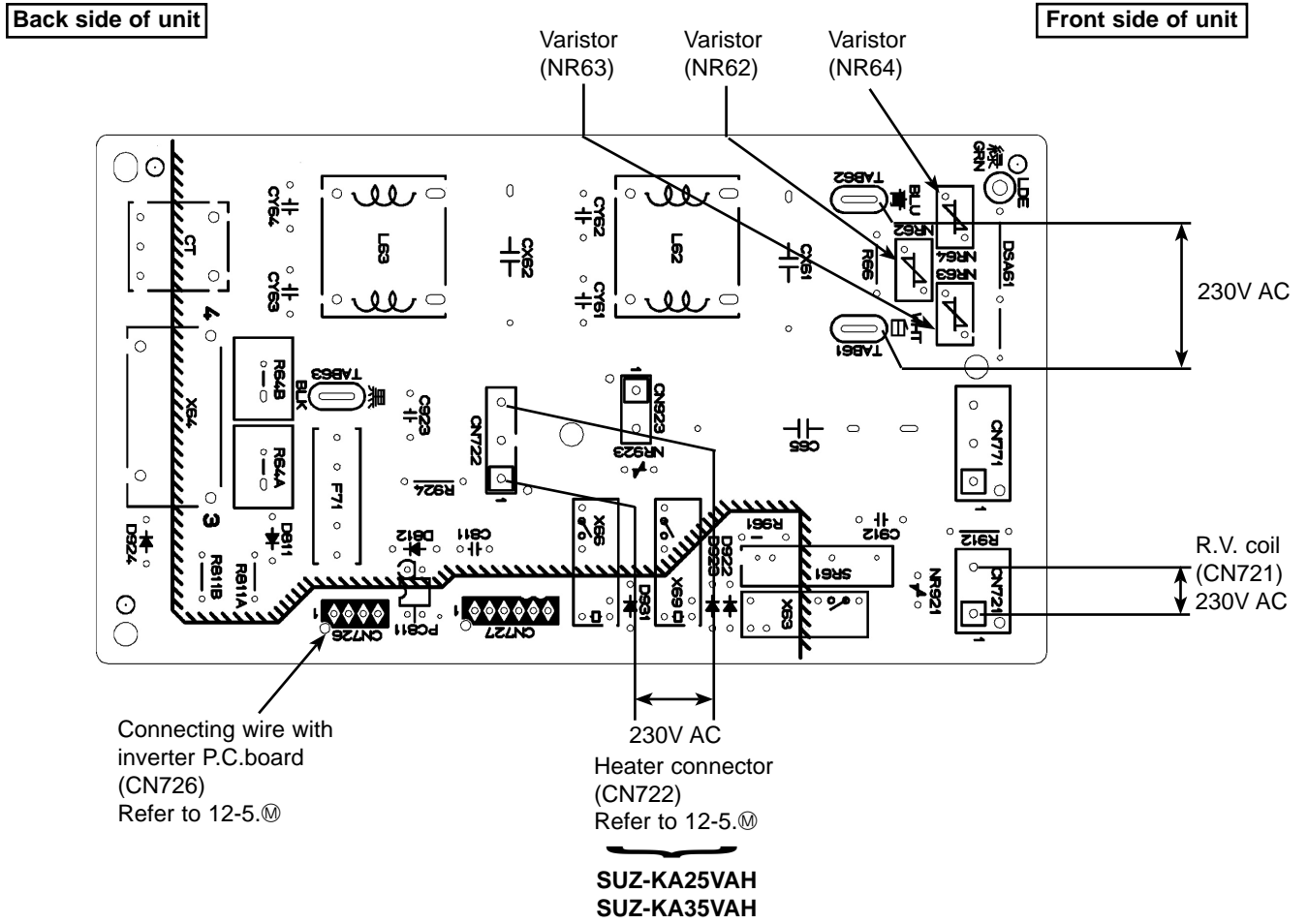

**12-6-3. Inverter P.C. board**  
**SUZ-KA25VAR1.TH SUZ-KA35VAR1.TH**  
**SUZ-KA25VAHR1.TH SUZ-KA35VAHR1.TH**

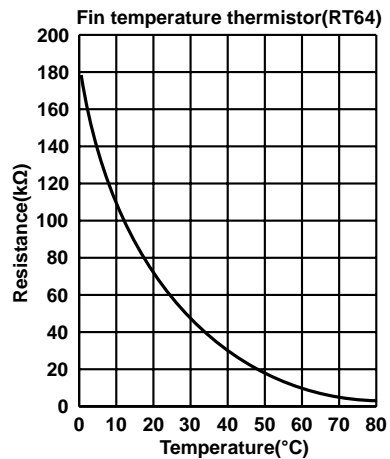
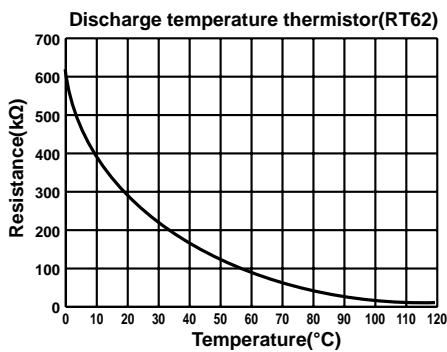
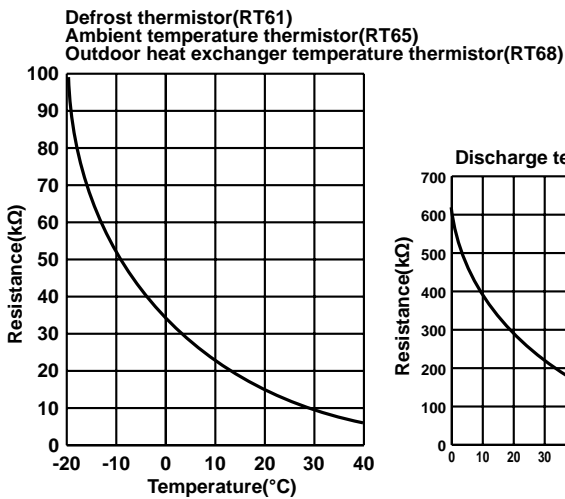
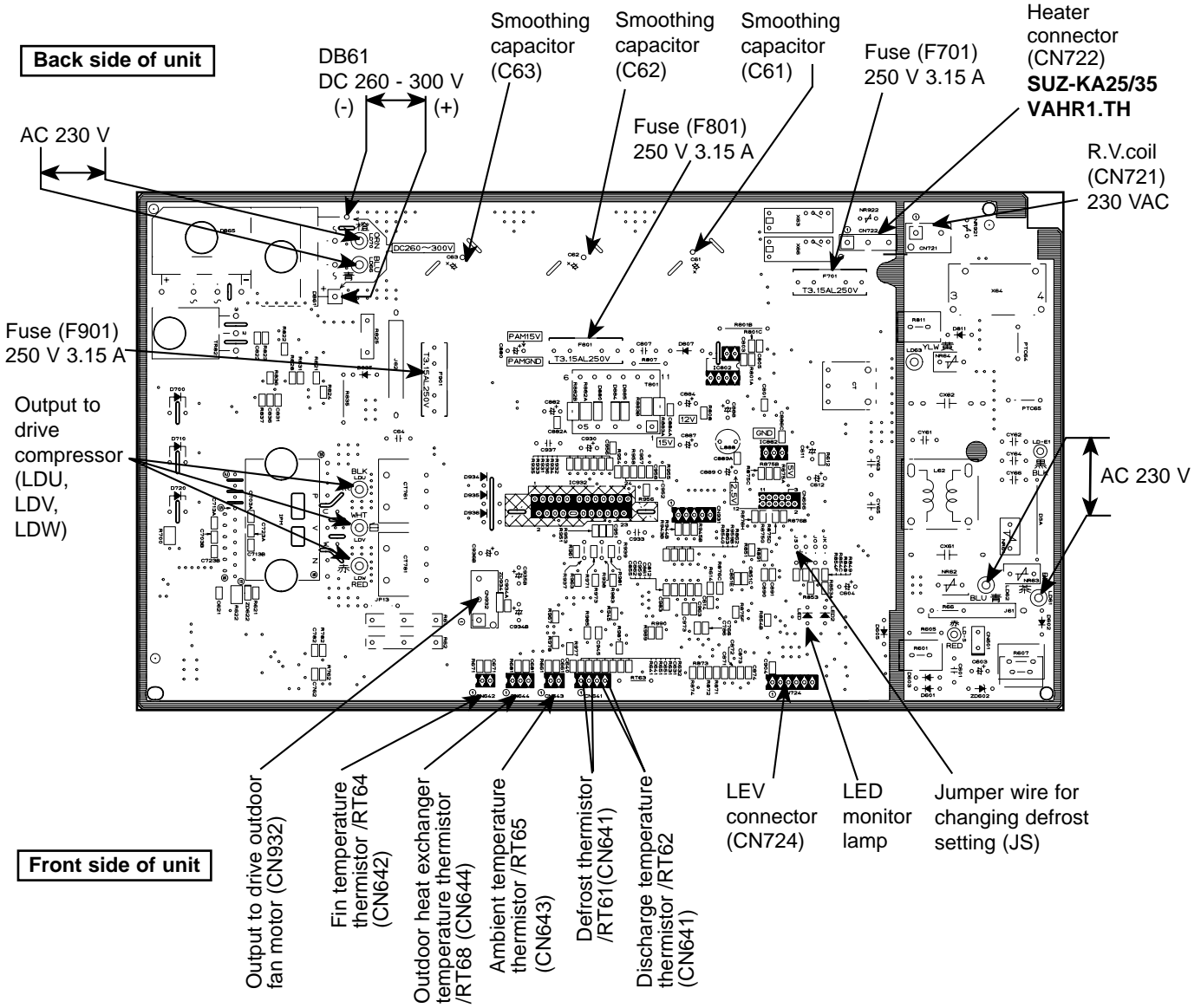

# 12-6-4. Outdoor electronic control P.C. board

SUZ-KA50VA<sub>(1)</sub>.TH SUZ-KA60VA<sub>(1)</sub>.TH SUZ-KA60VAR2.TH SUZ-KA71VA<sub>(1)</sub>.TH

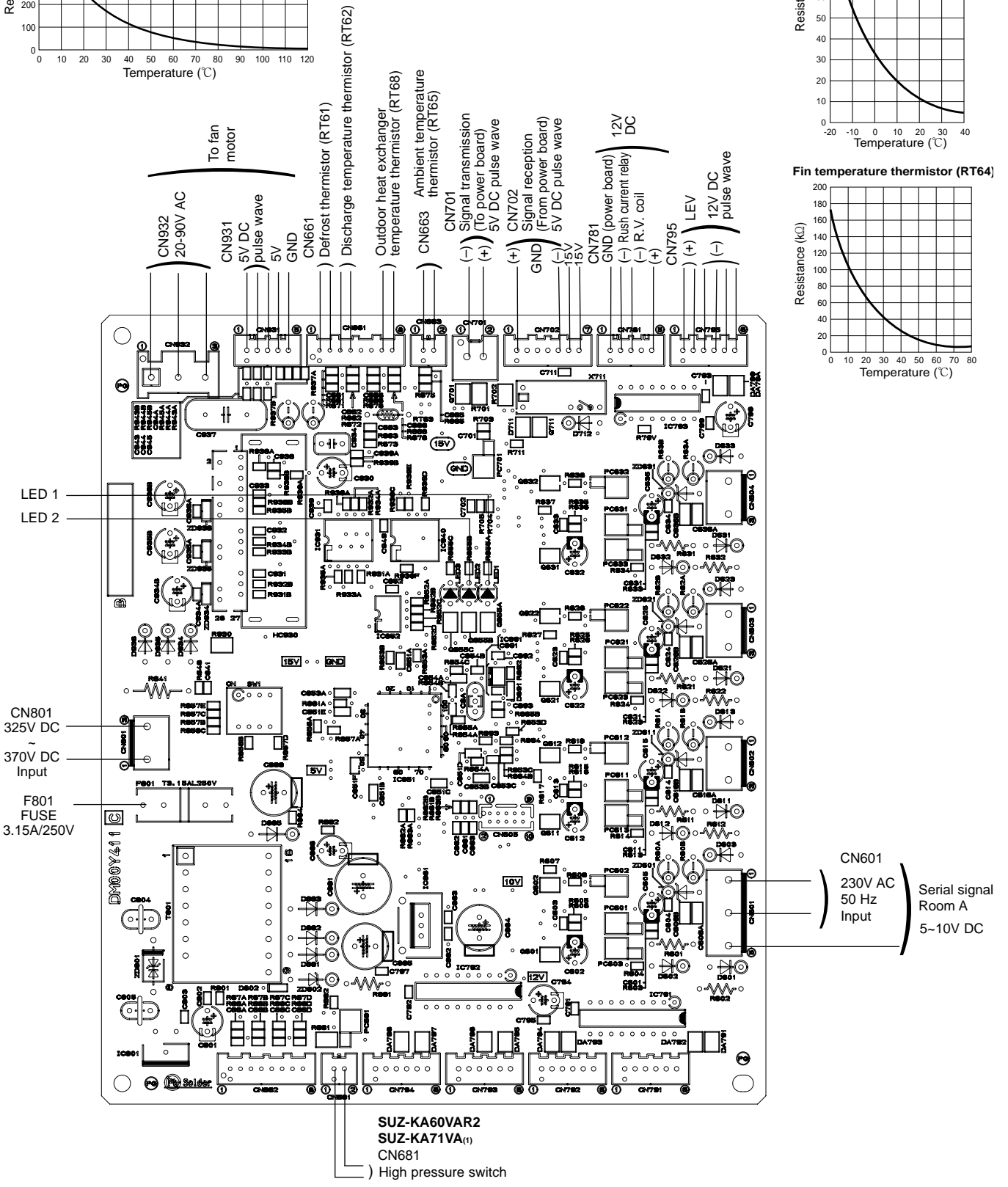
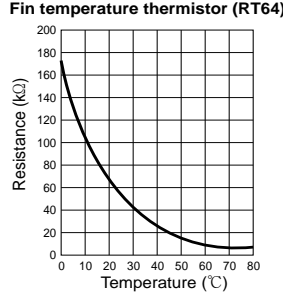
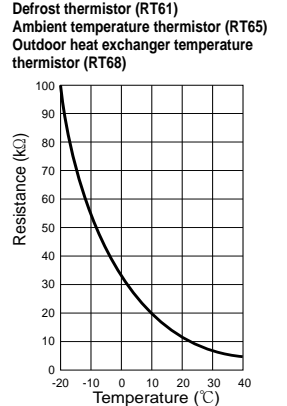
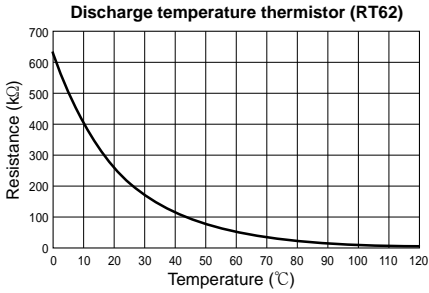

### 12-6-5. Noise filter P.C. board

SUZ-KA50VA(1).TH SUZ-KA60VA(1).TH SUZ-KA60VAR2.TH SUZ-KA71VA(1).TH

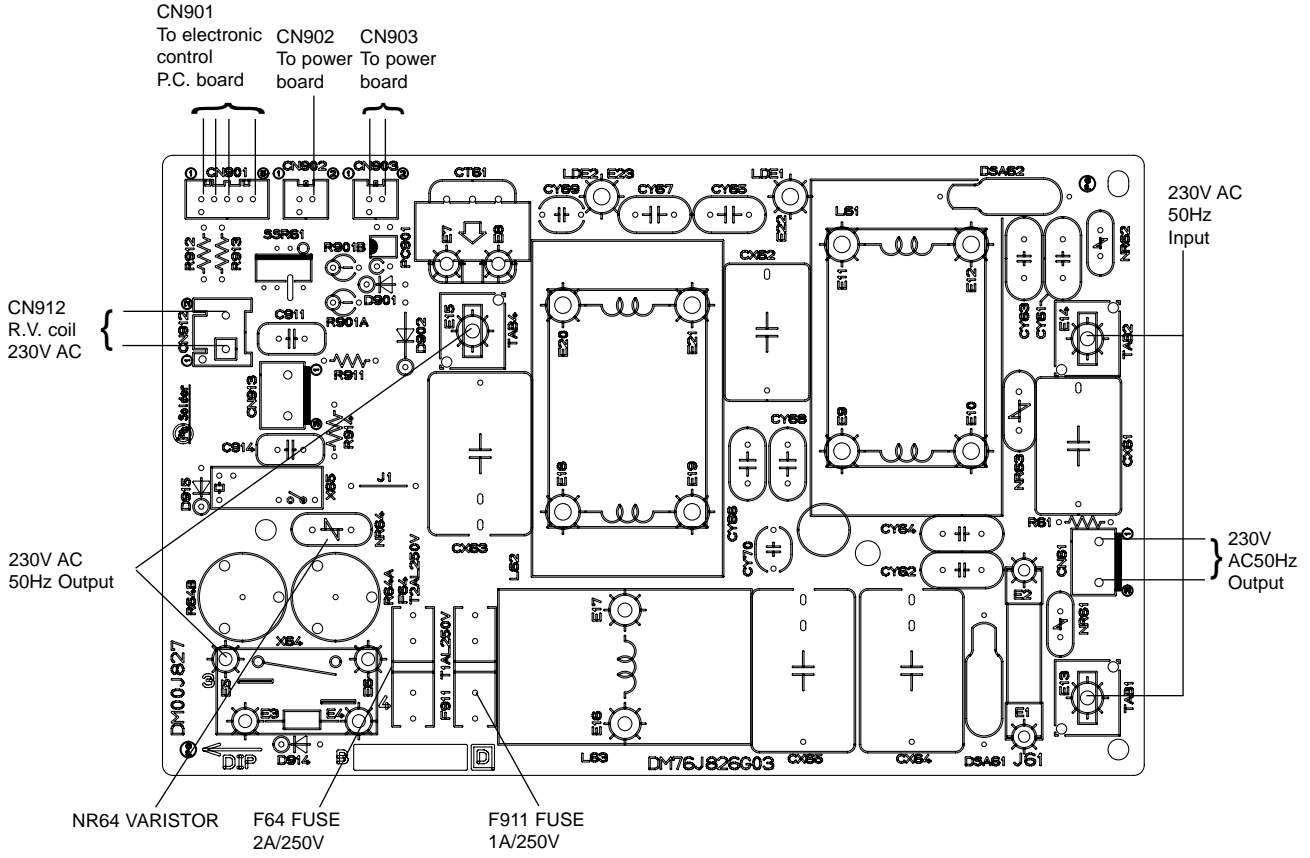

## 12-6-6. Outdoor power board

SUZ-KA50VA<sub>(1)</sub>.TH SUZ-KA60VA<sub>(1)</sub>.TH SUZ-KA60VAR2 SUZ-KA71VA<sub>(1)</sub>.TH

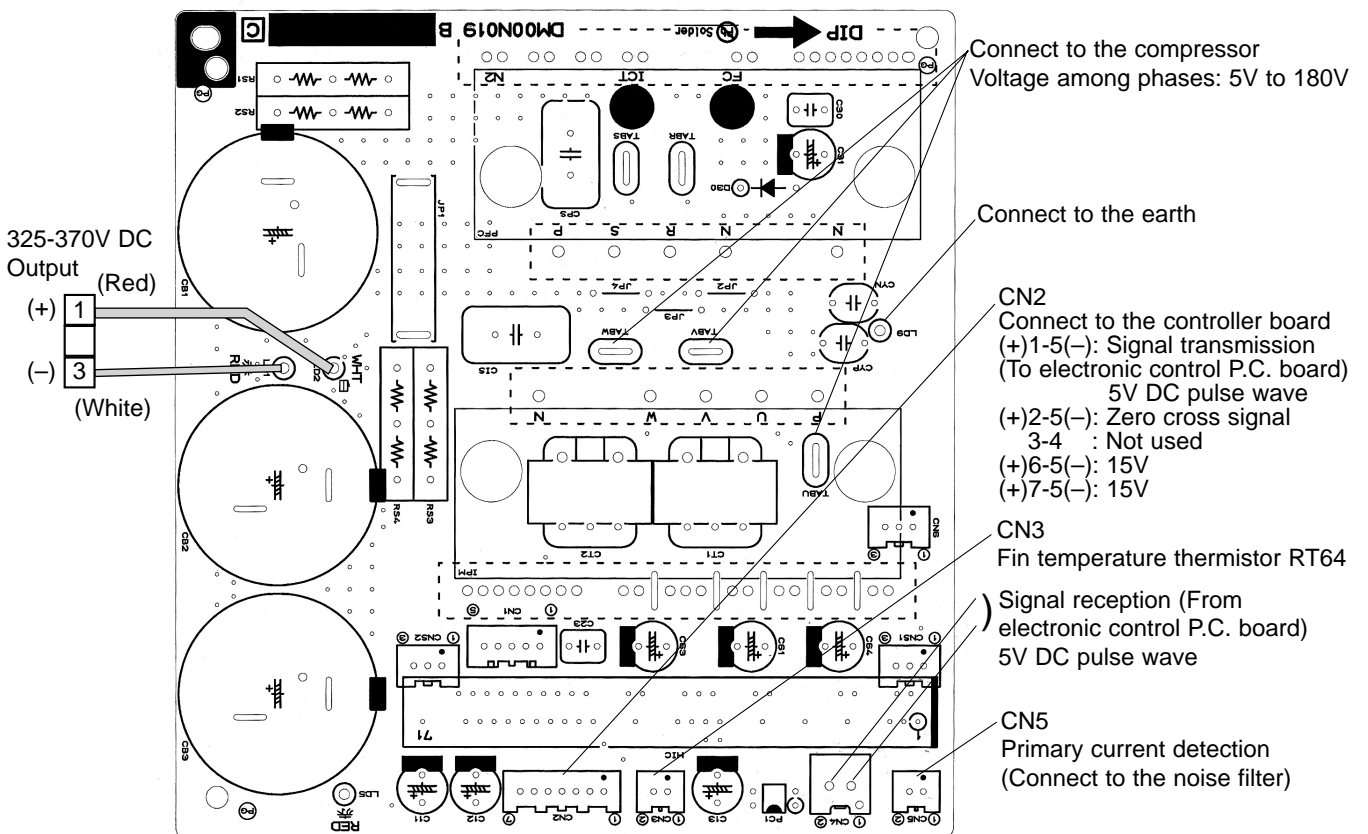
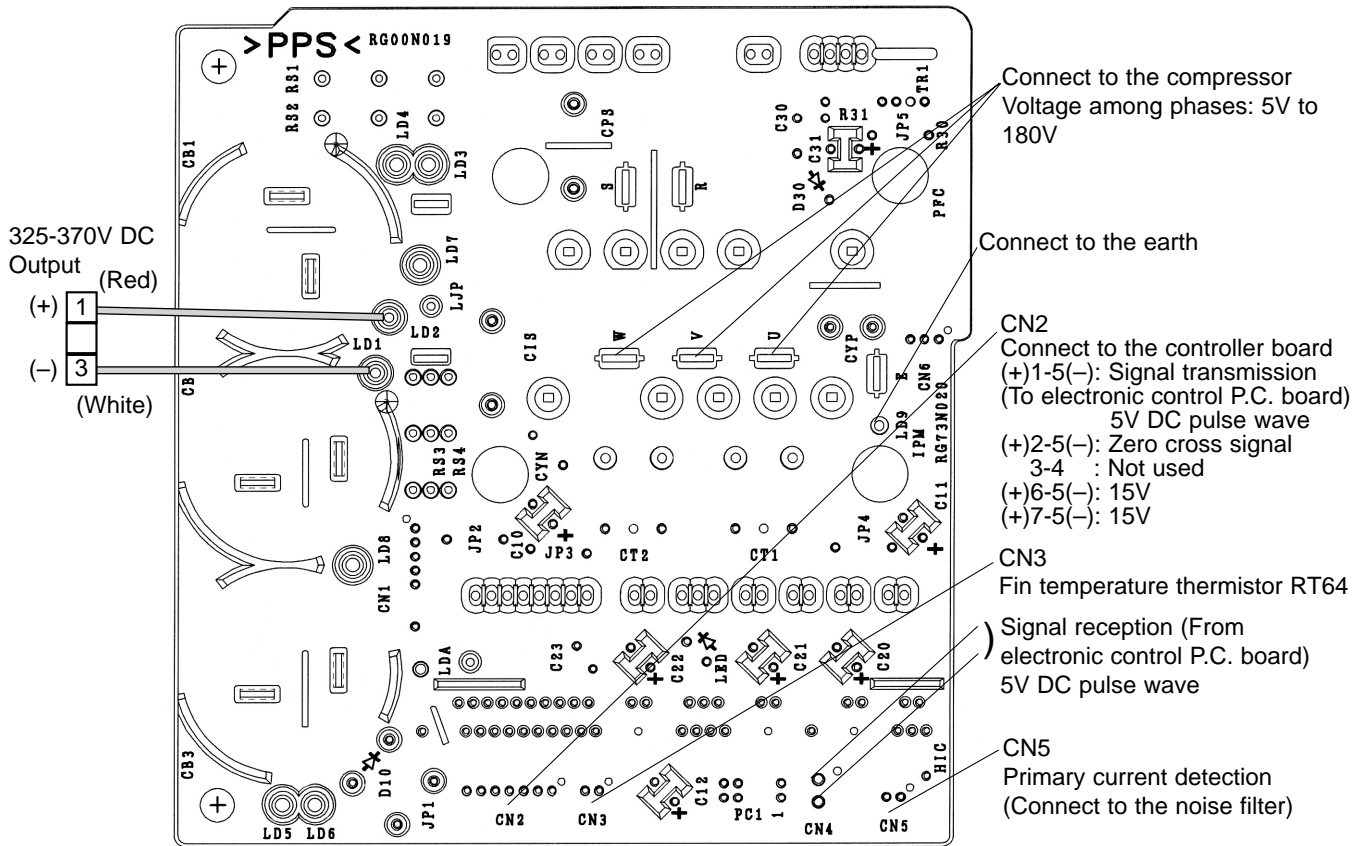

# 12-6-7. Inverter P.C. board SUZ-KA50VAR2.TH

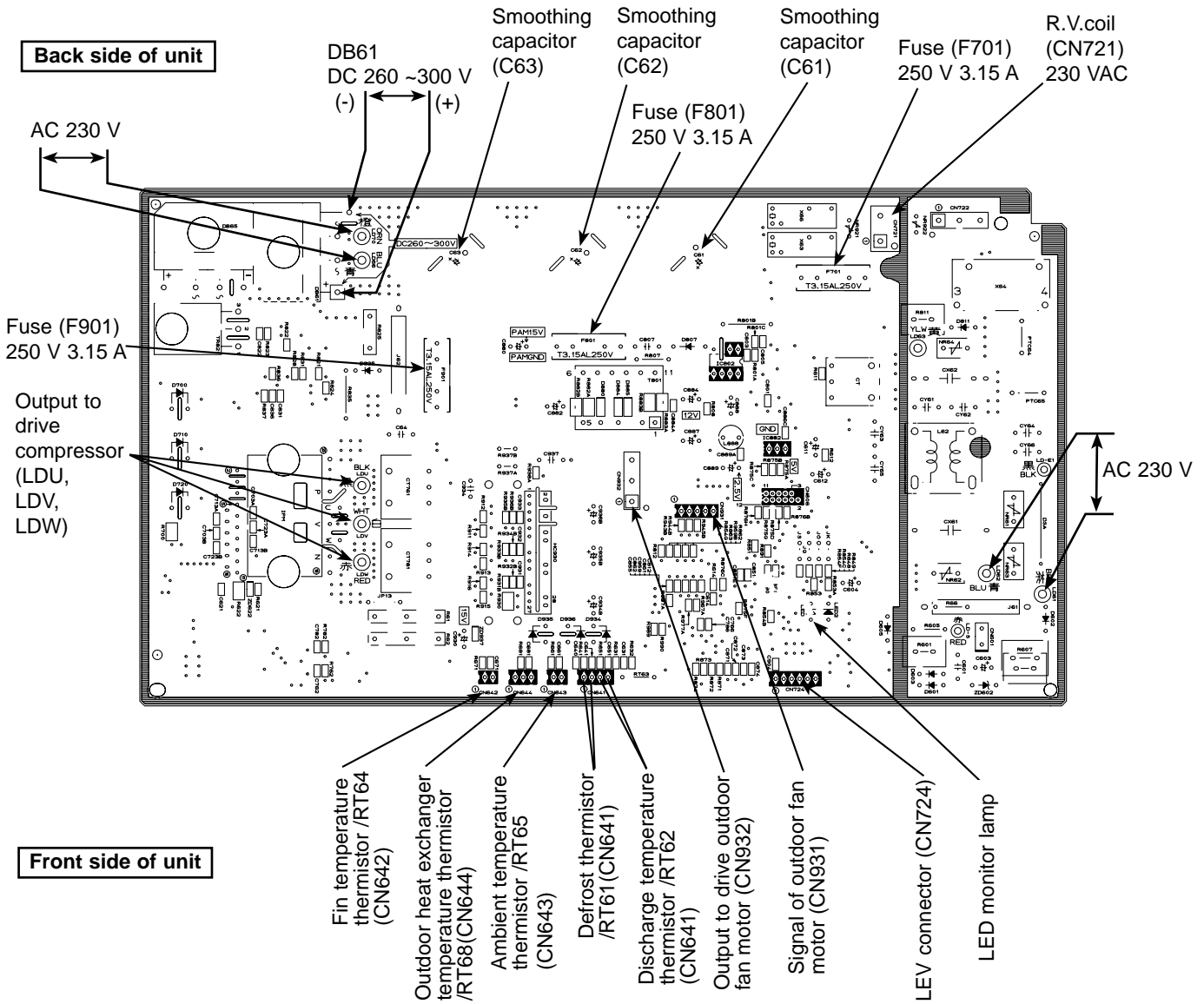

Defrost thermistor(RT61)  
Ambient temperature thermistor(RT65)  
Outdoor heat exchanger temperature thermistor(RT68)

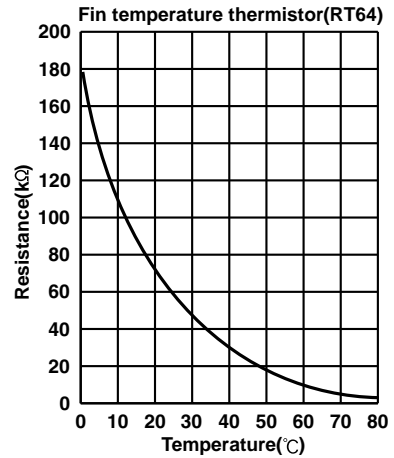
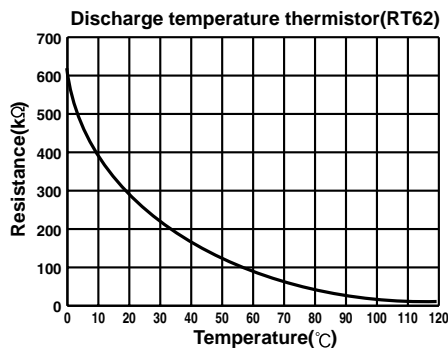
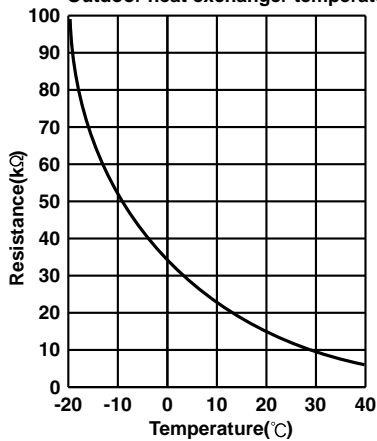

## &lt;"Terminal with locking mechanism" Detaching points&gt;

The terminal which has the locking mechanism can be detached as shown below.  
There are two types ( Refer to (1) and (2) ) of the terminal with locking mechanism.  
The terminal without locking mechanism can be detached by pulling it out.  
Check the shape of the terminal before detaching.

(1) Slide the sleeve and check if there is a locking lever or not.

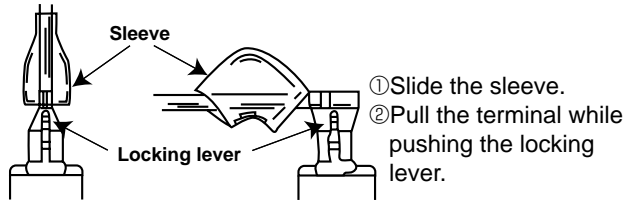

(2) The terminal with this connector has the locking mechanism.

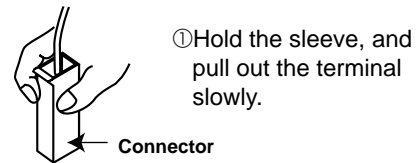

**SUZ-KA25VA.TH SUZ-KA35VA.TH**  
**SUZ-KA25VAH.TH SUZ-KA35VAH.TH**  
**OUTDOOR UNIT**

**NOTE: Turn OFF power supply before disassembling.**

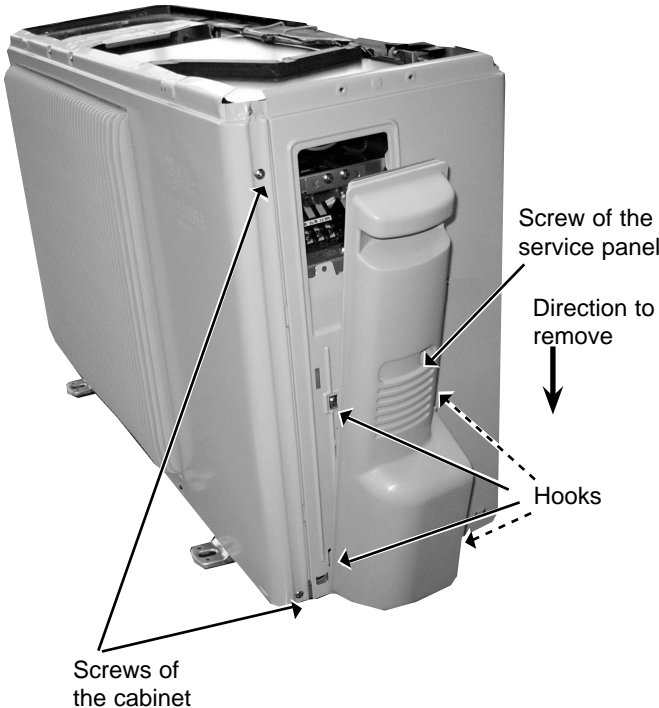
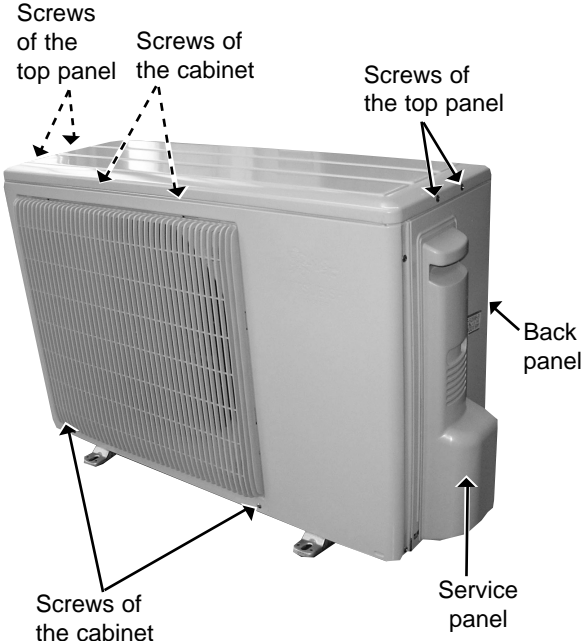
OPERATING PROCEDURE	PHOTOS
<p><b>1. Removing the cabinet.</b></p> <ol style="list-style-type: none"> <li>(1) Remove the screw fixing the service panel. (See Photo 2.)</li> <li>(2) Pull down the service panel and remove it. (See Photo 2.)</li> <li>(3) Disconnect the power supply and indoor/outdoor connecting wire.</li> <li>(4) Remove the screws fixing the top panel. (See Photo 1.)</li> <li>(5) Remove the top panel. (See Photo 1.)</li> <li>(6) Remove the screws fixing the cabinet.</li> <li>(7) Remove the cabinet.</li> <li>(8) Remove the screws fixing the back panel.</li> <li>(9) Remove the back panel.</li> </ol> <p><b>Photo 2</b></p> 	<p><b>Photo 1</b></p> 

## OPERATING PROCEDURE

### 2. Removing the inverter assembly, inverter P.C. board and power P.C. board

- (1) Remove the top panel, cabinet and service panel.  
(Refer to procedure 1.)
- (2) Disconnect the power supply and indoor/outdoor connecting wire and remove the back panel. (Refer to procedure 1.)
- (3) Disconnect the ground wires (See Photo 3.), the lead wire to the reactor and the following connectors;  
<Power P.C. board>  
CN721 (4-way valve)  
CN722 (Defrost heater) SUZ-KA25/KA35VAH  
<Inverter P.C. board>  
CN931, CN932 (Fan motor)  
CN641 (Defrost thermistor and discharge temperature thermistor)  
CN643 (Ambient temperature thermistor)  
CN724 (LEV)
- (4) Remove the compressor connector (CN61).
- (5) Remove the screws fixing the relay panel. (See Photo 3.)
- (6) Remove the inverter assembly. (See Photo 3.)
- (7) Disconnect all connectors and lead wires on the inverter P.C. board. (See Photo 4.)
- (8) Remove the inverter P.C. board from the inverter assembly.
- (9) Remove the screw fixing the power P.C. board. (See Photo 4.)
- (10) Disconnect all connectors and lead wires on the power P.C. board.
- (11) Remove the power P.C. board from the inverter assembly.

### 3. Removing R.V. coil

- (1) Remove the top panel, cabinet and service panel.  
(Refer to procedure 1.)
- (2) Disconnect the power supply and indoor/outdoor connecting wire and remove the back panel. (Refer to procedure 1.)
- (3) Remove the inverter assembly. (Refer to procedure 2.)
- (4) Remove the R.V. coil. (See Photo 5.)

### 4. Removing the discharge temperature thermistor and defrost thermistor

- (1) Remove the top panel, cabinet and service panel.  
(Refer to procedure 1.)
- (2) Disconnect the power supply and indoor/outdoor connecting wire and remove the back panel. (Refer to procedure 1.)
- (3) Remove the inverter assembly. (Refer to procedure 2.)
- (4) Pull out the discharge temperature thermistor from its holder. (See Photo 5.)
- (5) Pull out the defrost thermistor from its holder. (See Photo 6.)

## PHOTOS

Photo 3

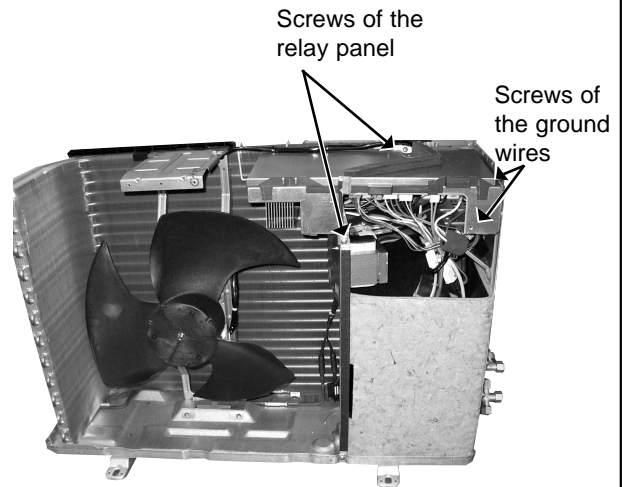

Photo 4

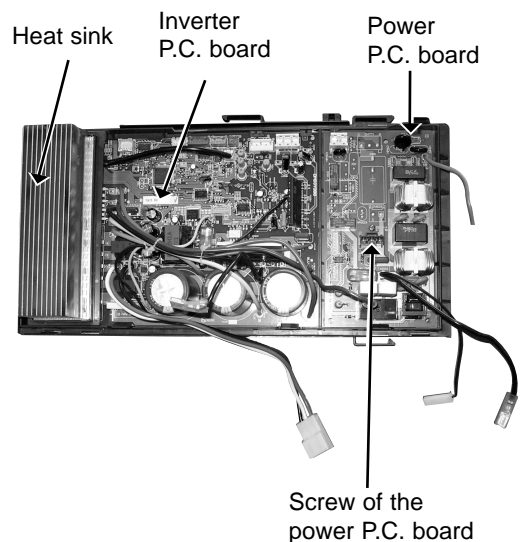
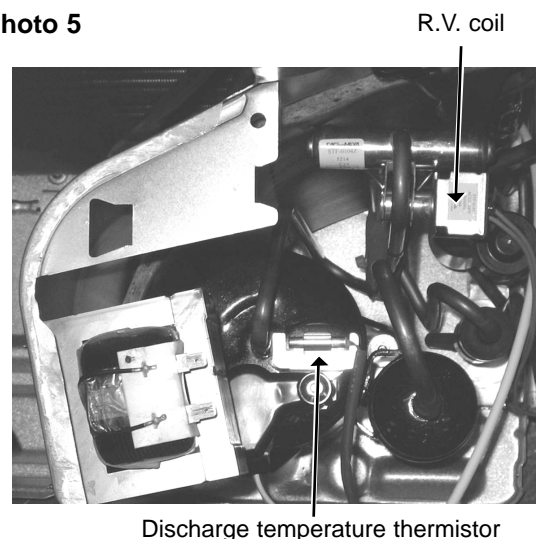

Photo 5





## OPERATING PROCEDURE

### 5. Removing outdoor fan motor

- (1) Remove the top panel, cabinet and service panel.  
(Refer to procedure 1.)
- (2) Disconnect the power supply and indoor/outdoor connecting wire and remove the back panel. (Refer to procedure 1.)
- (3) Disconnect the connectors for outdoor fan motor.
- (4) Remove the propeller nut.
- (5) Remove the propeller.
- (6) Remove the screws fixing the fan motor. (See Photo 7.)
- (7) Remove the fan motor.

### 6. Removing the compressor and 4-way valve

- (1) Remove the top panel, cabinet and service panel.  
(Refer to procedure 1.)
- (2) Disconnect the power supply and indoor/outdoor connecting wire and remove the back panel. (Refer to procedure 1.)
- (3) Remove the inverter assembly. (Refer to procedure 2.)
- (4) Recover gas from the refrigerant circuit.

**NOTE:** Recover gas from the pipes until the pressure gauge shows 0 kg/cm<sup>2</sup> (0 MPa).

- (5) Detach the welded part of the suction and the discharge pipe connected with compressor.
- (6) Remove the nuts of compressor legs.
- (7) Remove the compressor.
- (8) Detach the welded part of pipes connected with 4-way valve. (See Photo 8.)

## PHOTOS

Photo 6

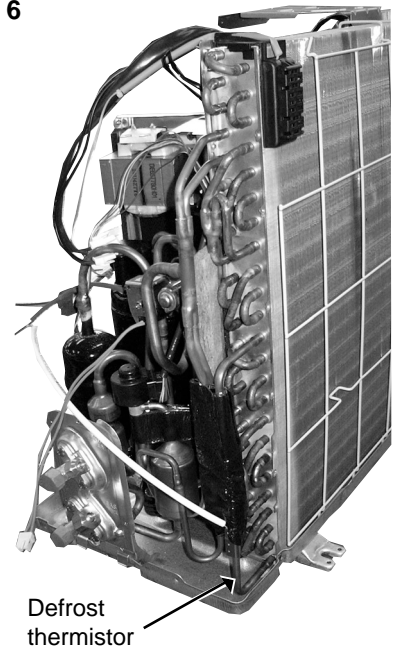
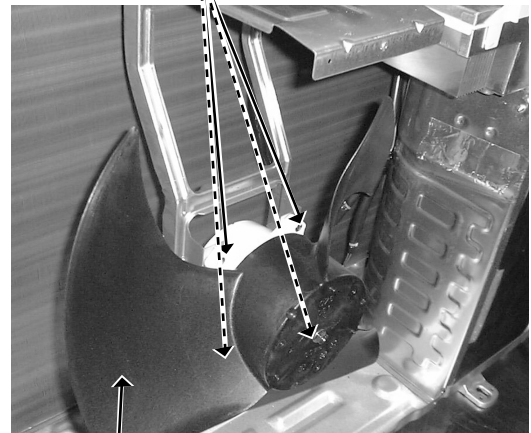

Photo 7

Screws of the outdoor fan motor



Propeller

Photo 8

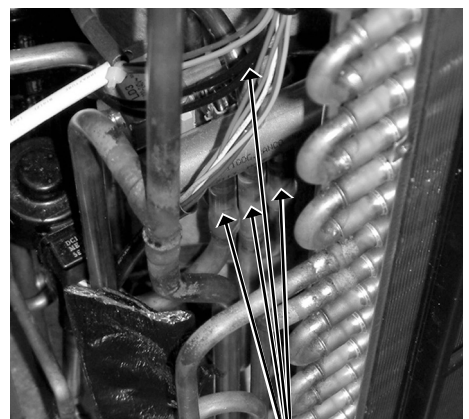

Welded parts of 4-way valve

SUZ-KA25VAR1.TH  
SUZ-KA25VAHR1.TH  
OUTDOOR UNIT

SUZ-KA35VAR1.TH  
SUZ-KA35VAHR1.TH

NOTE: Turn OFF power supply before disassembling.

### OPERATING PROCEDURE

#### 1. Removing the cabinet

- (1) Remove the screw fixing the service panel.
- (2) Pull down the service panel and remove it.
- (3) Disconnect the power supply and indoor/outdoor connecting wire.
- (4) Remove the screws fixing the top panel.
- (5) Remove the top panel.
- (6) Remove the screws fixing the cabinet.
- (7) Remove the cabinet.
- (8) Remove the screws fixing the back panel.
- (9) Remove the back panel.

### PHOTOS

Photo 1

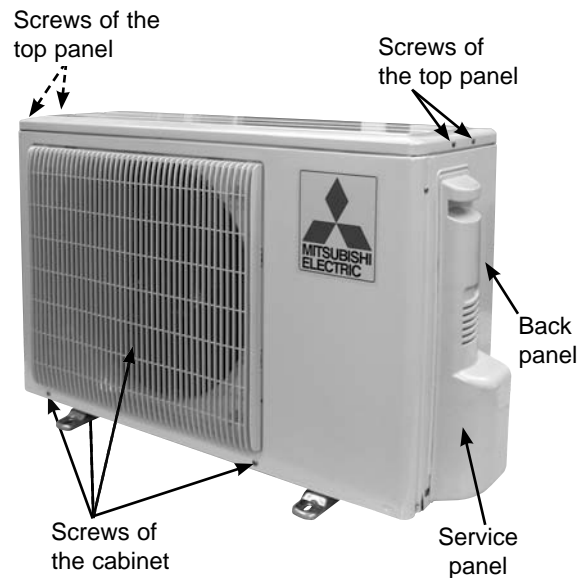
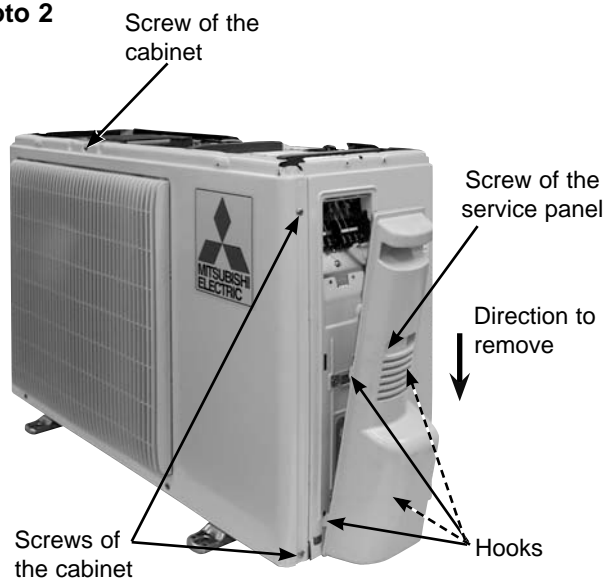

Photo 2



## OPERATING PROCEDURE

### 2. Removing the inverter assembly, inverter P.C. board

- (1) Remove the cabinet and panels. (Refer to procedure 1.)
- (2) Disconnect the lead wire to the reactor and the following connectors:  
<Inverter P.C. board>  
CN721 (R.V. coil)  
CN722 (Defrost heater) SUZ-KA25/35VAHR1.TH  
CN932 (Fan motor)  
CN641 (Defrost thermistor and discharge temperature thermistor)  
CN643 (Ambient temperature thermistor)  
CN644 (Outdoor heat exchanger temperature thermistor)  
CN724 (LEV)
- (3) Remove the compressor connector (CN61).
- (4) Remove the screws fixing the relay panel. (Photo 3)
- (5) Remove the inverter assembly. (Photo 4)
- (6) Remove the screw of the earth wire and screw of the T.B.support. (Photo 4)
- (7) Remove the relay panel from the inverter assembly.
- (8) Remove the inverter P.C. board from the relay panel.

### 3. Removing R.V. coil

- (1) Remove the cabinet and panels. (Refer to procedure 1.)
- (2) Disconnect the following connectors:  
<Inverter P.C. board>  
CN721 (R.V. coil)
- (3) Remove the R.V. coil. (Photo 5)

### 4. Removing the discharge temperature thermistor, defrost thermistor, outdoor heat exchanger temperature thermistor and ambient temperature thermistor

- (1) Remove the cabinet and panels. (Refer to procedure 1.)
- (2) Disconnect the lead wire to the reactor and the following connectors:  
<Inverter P.C. board>  
CN641 (Defrost thermistor and discharge temperature thermistor)  
CN643 (Ambient temperature thermistor)  
CN644 (Outdoor heat exchanger temperature thermistor)
- (3) Pull out the discharge temperature thermistor from its holder. (Photo 5)
- (4) Pull out the defrost thermistor from its holder. (Photo 6)
- (5) Pull out the outdoor heat exchanger temperature thermistor from its holder. (Photo 6)
- (6) Pull out the ambient temperature thermistor from its holder.

## PHOTOS

Photo 3

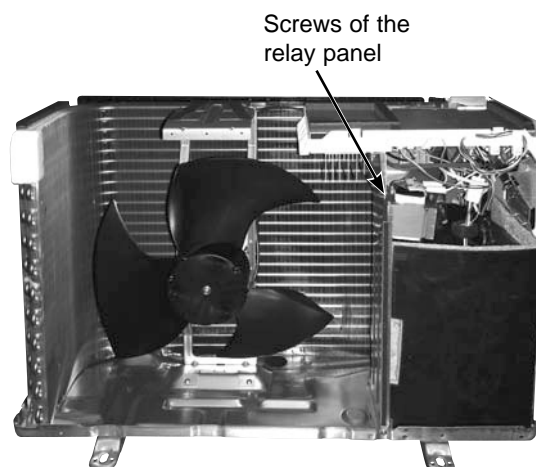

Photo 4 (Inverter assembly)

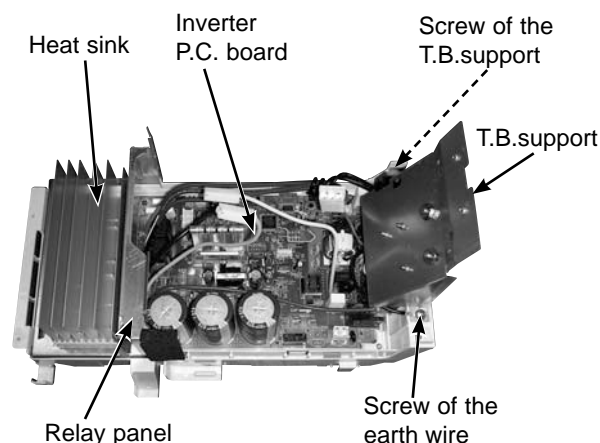

Photo 5



## OPERATING PROCEDURE

### 5. Removing outdoor fan motor

- (1) Remove the cabinet and panels. (Refer to procedure 1.)
- (2) Disconnect the following connectors:
  - <Inverter P.C. board>
  - CN932 (Fan motor)
- (3) Remove the propeller nut. (Photo 7)
- (4) Remove the propeller. (Photo 7)
- (5) Remove the screws fixing the fan motor. (Photo 7)
- (6) Remove the fan motor.

### 6. Removing the compressor and 4-way valve

- (1) Remove the cabinet and panels. (Refer to procedure 1.)
- (2) Remove the inverter assembly. (Refer to procedure 2.)
- (3) Recover gas from the refrigerant circuit.  
**NOTE:** Recover gas from the pipes until the pressure gauge shows 0 kg/cm<sup>2</sup> (0 MPa).
- (4) Detach the welded part of the suction and the discharge pipe connected with compressor.
- (5) Remove the nuts of compressor legs.
- (6) Remove the compressor.
- (7) Detach the welded part of pipes connected with 4-way valve. (Photo 8)

## PHOTOS

Photo 6

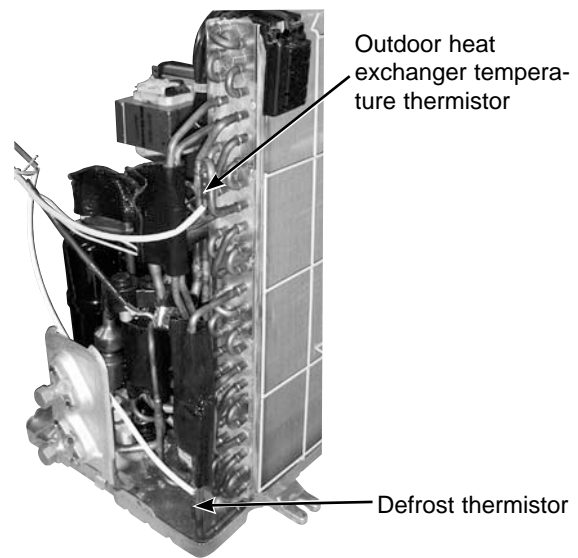

Photo 7

Screws of the outdoor fan motor

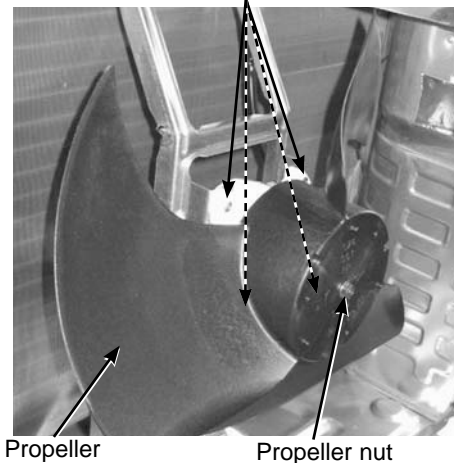
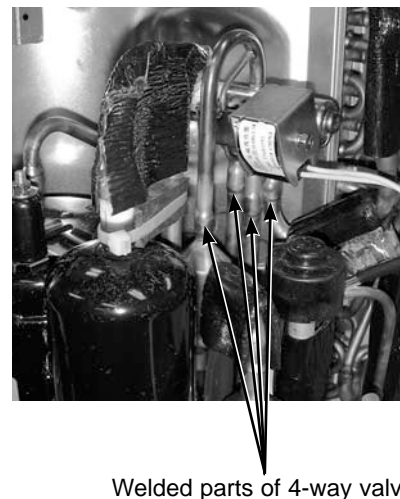
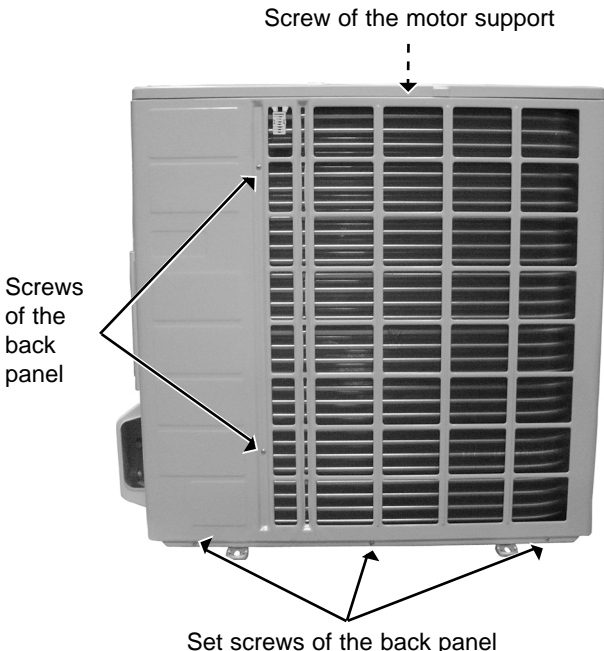
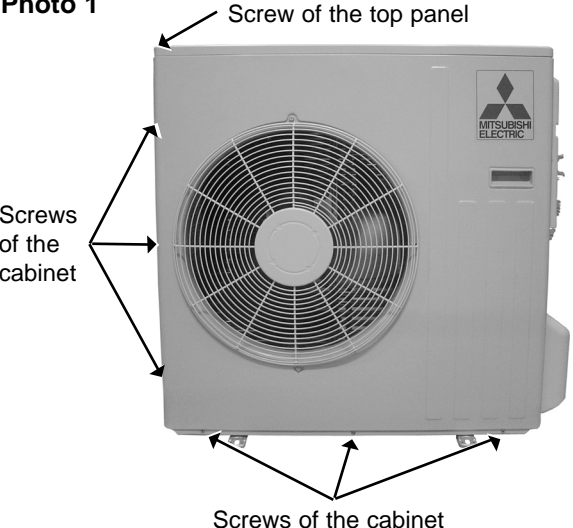
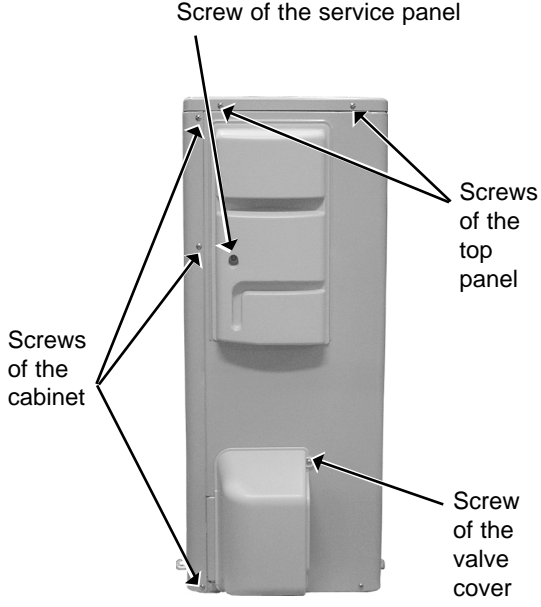

Photo 8



**SUZ-KA50VA.TH      SUZ-KA60VA.TH      SUZ-KA71VA.TH**  
**SUZ-KA50VA<sub>1</sub>.TH      SUZ-KA60VA<sub>1</sub>.TH      SUZ-KA71VA<sub>1</sub>.TH**  
**SUZ-KA50VAR2.TH      SUZ-KA60VAR2.TH**  
**OUTDOOR UNIT**

**NOTE: Turn OFF power supply before disassembling.**

OPERATING PROCEDURE	PHOTOS
<p><b>1. Removing the cabinet</b></p> <ol style="list-style-type: none"> <li>(1) Remove the screws of the service panel.</li> <li>(2) Remove the screws of the top panel.</li> <li>(3) Remove the screw of the valve cover.</li> <li>(4) Remove the service panel.</li> <li>(5) Remove the top panel.</li> <li>(6) Remove the valve cover.</li> <li>(7) Remove the screws of the cabinet.</li> <li>(8) Remove the cabinet.</li> <li>(9) Remove the screws of the back panel.</li> <li>(10) Remove the back panel.</li> </ol> <p><b>Photo 3</b></p>  <p>Screw of the motor support</p> <p>Screws of the back panel</p> <p>Set screws of the back panel</p>	<p><b>Photo 1</b></p>  <p>Screw of the top panel</p> <p>Screws of the cabinet</p> <p>Screws of the cabinet</p> <p><b>Photo 2</b></p>  <p>Screw of the service panel</p> <p>Screws of the top panel</p> <p>Screws of the cabinet</p> <p>Screw of the valve cover</p>

## OPERATING PROCEDURE

### 2. Removing the inverter assembly, inverter P.C. board and power board (except for SUZ-KA50VAR2.TH)

- (1) Remove the top panel, cabinet and service panel. (Refer to 1.)
- (2) Remove the back panel. (Refer to procedure 1.)
- (3) Disconnect the following connectors;
  - <Electronic control P.C. board>
  - CN931 and CN932 (Fan motor)
  - CN795 (LEV)
  - CN661 (Discharge temperature thermistor, defrost thermistor and outdoor heat exchanger temperature thermistor)
  - <Noise filter P.C. board>
  - CN912 (4-way valve)
- (4) Remove the compressor connector.
- (5) Remove the screws fixing the relay panel.
- (6) Remove the inverter assembly.
- (7) Disconnect all connectors and lead wires on the electronic control P.C. board.
- (8) Remove the electronic control P.C. board from the inverter assembly.
- (9) Remove the screws fixing the power board assembly.
- (10) Disconnect all connectors and lead wires on the power board.
- (11) Remove the power board from the inverter assembly.
- (12) Disconnect all connectors and lead wires on the noise filter P.C. board.
- (13) Remove the noise filter P.C. board from the inverter assembly.

### (SUZ-KA50VAR2.TH)

- (1) Remove the cabinet and panels. (Refer to procedure 1.)
- (2) Disconnect the lead wire to the reactor and the following connectors;
  - <Inverter P.C. board>
  - CN721 (R.V.coil)
  - CN932 (Fan motor)
  - CN641 (Defrost thermistor and discharge temperature thermistor)
  - CN643 (Ambient temperature thermistor)
  - CN644 (Outdoor heat exchanger temperature thermistor)
  - CN724 (LEV)
- (3) Remove the compressor connector (CN61).
- (4) Remove the screws fixing the relay panel. (Photo 5)
- (5) Remove the inverter assembly. (Photo 6)
- (6) Remove the screw of the earth wire and screw of the T.B.support. (Photo 6)
- (7) Remove the screw of the PB fixture.
- (8) Remove the relay panel from the PB support.

### 3. Removing R.V. coil

- (1) Remove the top panel, cabinet and service panel. (Refer to procedure 1)
  - (2) Remove the back panel. (Refer to procedure 1.)
  - (3) Disconnect the following connectors;
    - Except for SUZ-KA50VAR2.TH
    - <Noise filter P.C. board>
    - CN912 (R.V. coil)
- SUZ-KA50VAR2.TH  
 <inverter P.C. board>  
 CN721 (R.V. coil)
- (4) Remove the R.V. coil. (Photo 11)

## PHOTOS

Photo 4

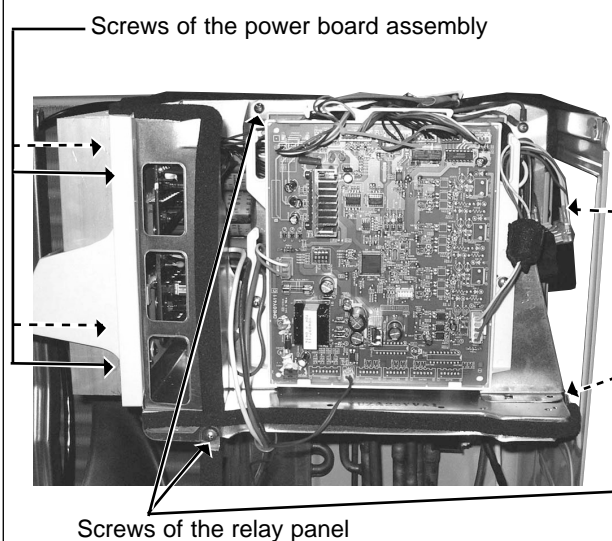

Photo 5 (SUZ-KA50VAR2.TH)

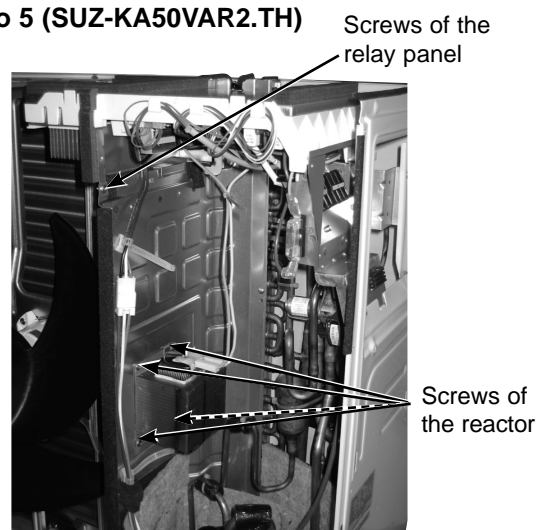
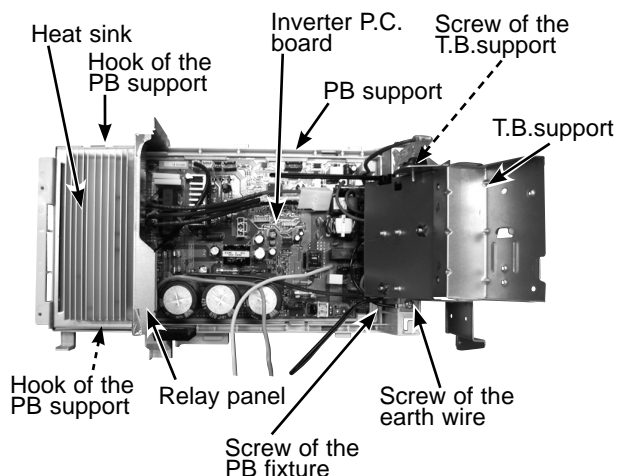

Photo 6 (SUZ-KA50VAR2.TH)



## OPERATING PROCEDURE

### 4. Removing the defrost thermistor, discharge temperature thermistor, outdoor heat exchanger temperature thermistor and ambient temperature thermistor

- (1) Remove the top panel, cabinet and service panel. (Refer to procedure 1.)
- (2) Remove the back panel. (Refer to procedure 1.)
- (3) Remove the inverter assembly. (Refer to procedure 2.)
- (4) Pull out the defrost thermistor from its holder. (Photo 8)
- (5) Pull out the discharge temperature thermistor from its holder. (Photo 7)
- (6) Pull out the outdoor heat exchanger temperature thermistor from its holder. (Photo 8)
- (7) Pull out the ambient temperature thermistor from its holder. (Photo 8)

## PHOTOS

Photo 7

Discharge temperature thermistor

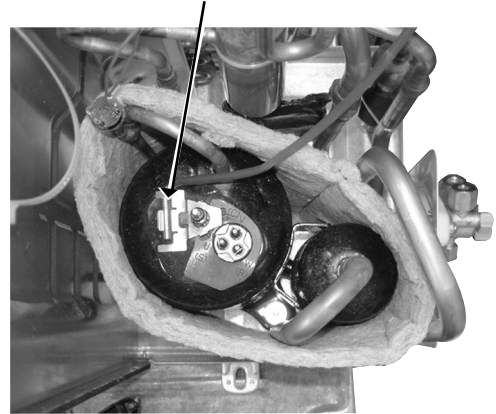
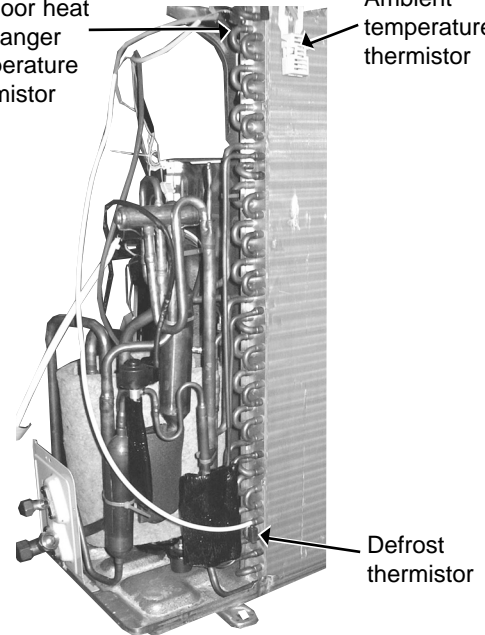

Photo 8

Outdoor heat exchanger temperature thermistor

Ambient temperature thermistor



### 5. Removing outdoor fan motor

- (1) Remove the top panel, cabinet and service panel. (Refer to procedure 1.)
- (2) Remove the back panel. (Refer to procedure 1.)
- (3) Disconnect the following connectors;  
Except for SUZ-KA50VAR2.TH  
<Electric control P.C. board>  
CN931 and CN932 (Fan motor)  
  
SUZ-KA50VAR2.TH  
<Inverter P.C. board>  
CN931 and CN932 (Fan motor)
- (4) Remove the propeller.
- (5) Remove the screws fixing the fan motor.
- (6) Remove the fan motor.

Photo 9

Propeller

Screws of the outdoor fan motor

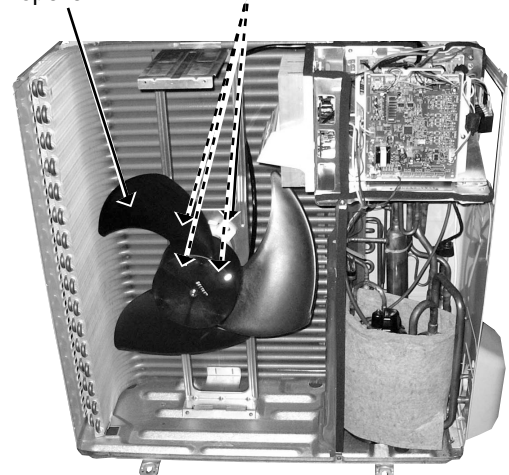

## OPERATING PROCEDURE

### 6. Removing the compressor and 4-way valve

(1) Remove the top panel, cabinet and service panel.  
(Refer to procedure 1.)

(2) Remove the back panel. (Refer to procedure 1.)

(3) Remove the inverter assembly. (Refer to procedure 2.)

(4) Recover gas from the refrigerant circuit.

**NOTE:** Recover gas from the pipes until the pressure gauge shows 0 kg/cm<sup>2</sup> (0 MPa).

(5) Detach the welded part of the suction and the discharge pipe connected with compressor. (Photo 11)

(6) Remove the compressor nuts.

(7) Remove the compressor.

(8) Detach the welded part of 4-way valve and pipe. (Photo 10)

## PHOTOS

Photo 10

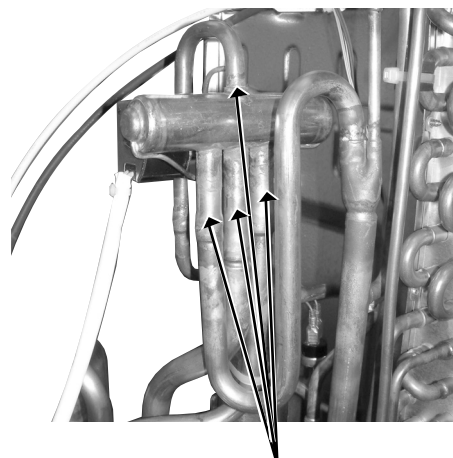

Welded parts of 4-way valve

Photo 11

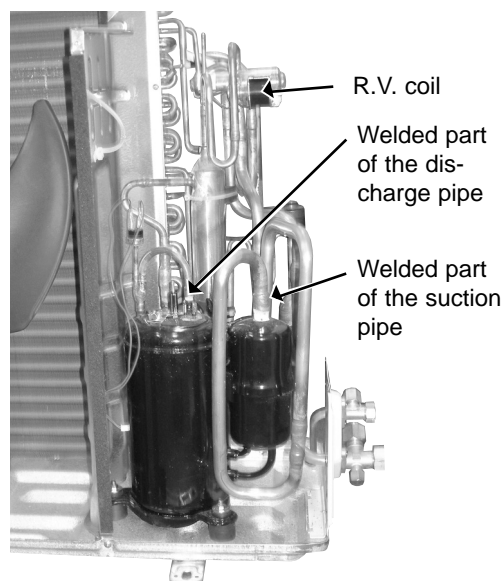

Photo 12

### 7. Removing the reactor

(1) Remove the top panel. (Refer to procedure 1.)

(2) Disconnect the reactor lead wire.

(3) Remove the screws of the reactor, and remove the reactor.

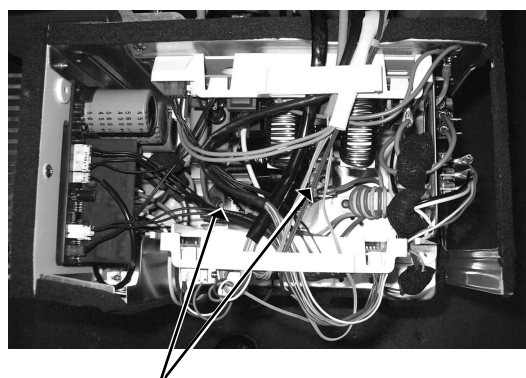

Screws of the reactor



# 14

## PARTS LIST (non-RoHS compliant)

SUZ-KA25VA.TH SUZ-KA35VA.TH  
 SUZ-KA25VAH.TH SUZ-KA35VAH.TH

### 14-1. OUTDOOR UNIT ELECTRICAL PARTS

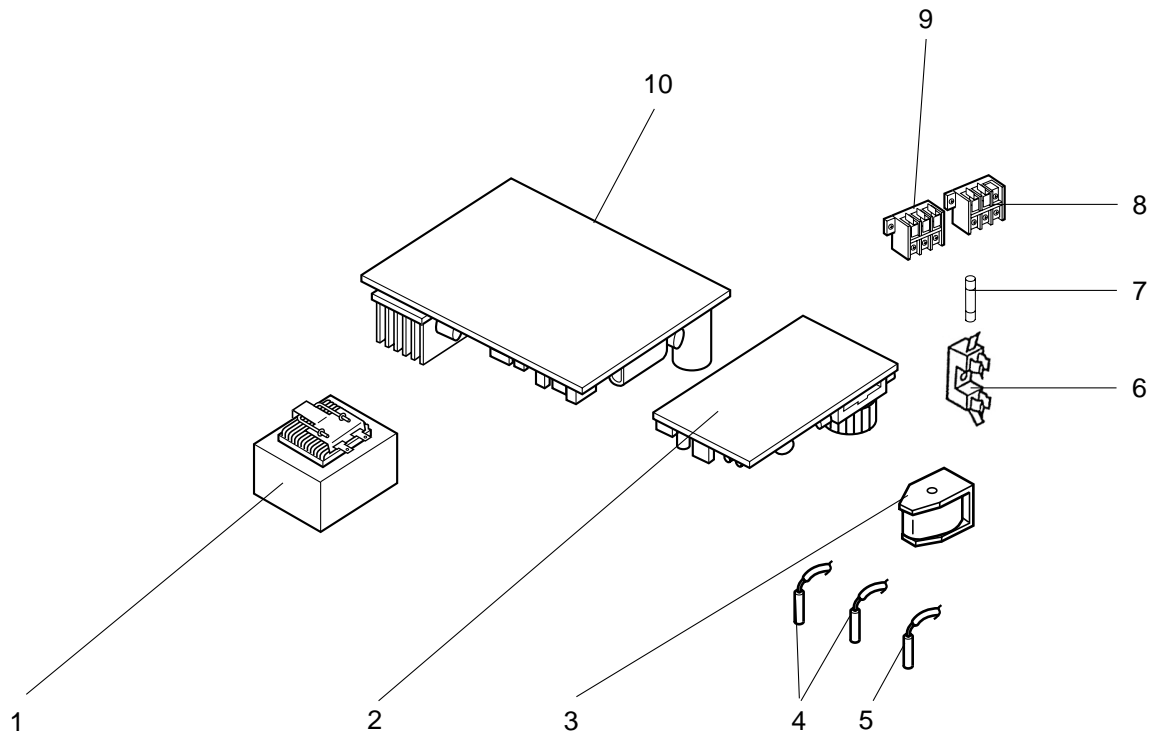

Part numbers that are circled are not shown in the illustration.

No.	Part No.	Part Name	Symbol in Wiring Diagram	Q'ty/unit				Remarks
				SUZ-KA25VA.TH	SUZ-KA25VAH.TH	SUZ-KA35VA.TH	SUZ-KA35VAH.TH	
1	E02 838 337	REACTOR	L61	1	1	1	1	
2	E02 927 444	POWER P.C. BOARD		1		1		
	E02 931 444	POWER P.C. BOARD			1		1	
3	E02 927 490	R.V. COIL	21S4	1	1	1	1	
4	E02 927 306	THERMISTOR SET	RT61,RT62	1	1	1	1	DEFROST, DISCHARGE
5	E02 927 308	AMBIENT TEMPERATURE THERMISTOR	RT65	1	1	1	1	
6	E02 735 241	FUSE HOLDER		1	1	1	1	
7	E02 735 382	FUSE	F61	1	1	1	1	250V/20A
8	E02 573 375	TERMINAL BLOCK	TB1	1	1	1	1	3P
9	E02 927 374	TERMINAL BLOCK	TB2	1	1	1	1	3P
10	E07 168 451	INVERTER P.C. BOARD		1				Including heat sink and RT64
	E07 184 451	INVERTER P.C. BOARD			1			Including heat sink and RT64
	E07 169 451	INVERTER P.C. BOARD				1		Including heat sink and RT64
	E07 185 451	INVERTER P.C. BOARD					1	Including heat sink and RT64
⑪	E02 127 382	FUSE	F71,F801	1	1	1	1	250V/3.15A
⑫	E02 661 385	VARISTOR	NR62,NR63,NR64	1	1	1	1	

# PARTS LIST (non-RoHS compliant)

SUZ-KA25VA.TH SUZ-KA35VA.TH  
SUZ-KA25VAH.TH SUZ-KA35VAH.TH

## 14-2. OUTDOOR UNIT STRUCTURAL PARTS AND FUNCTIONAL PARTS

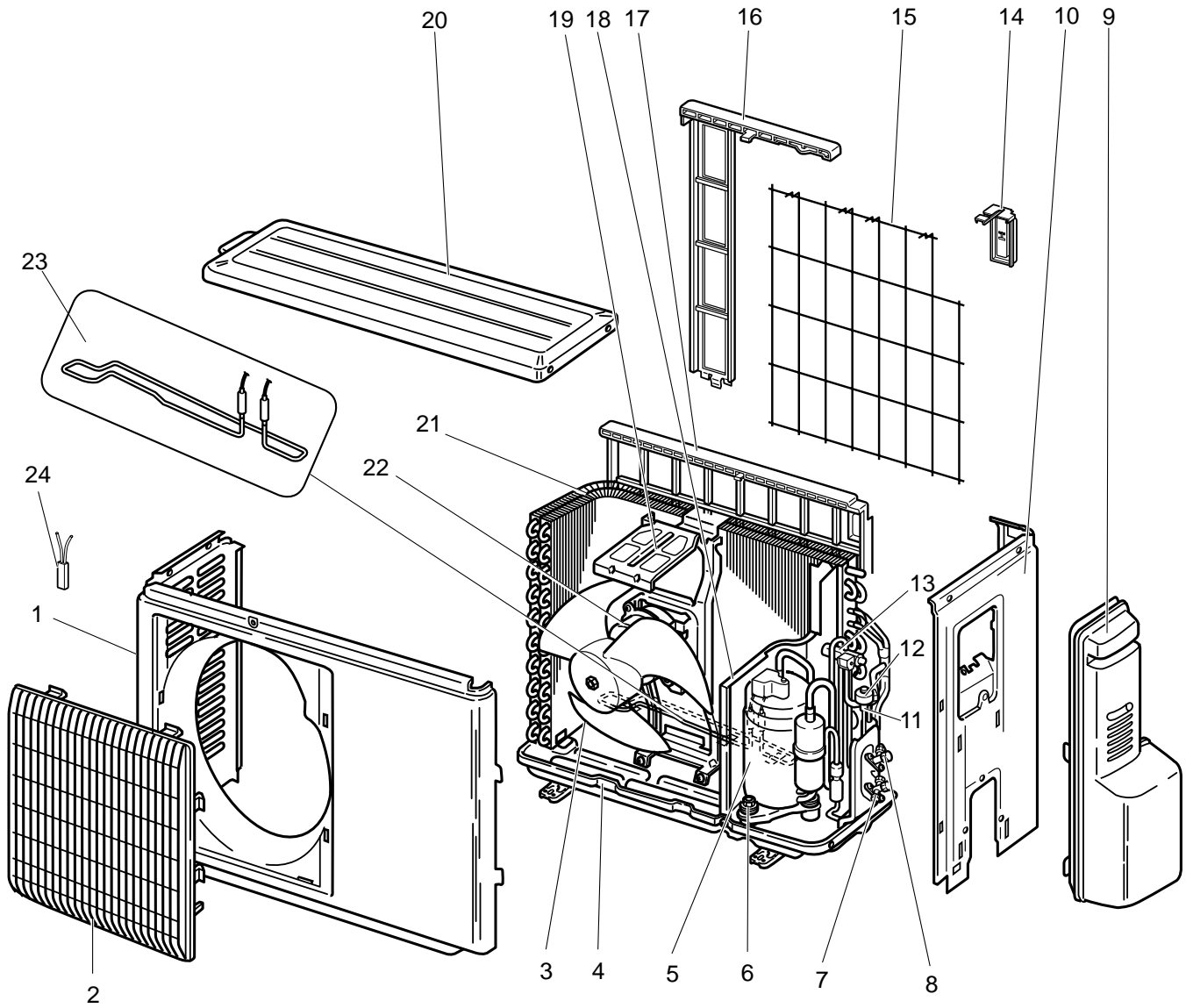

# PARTS LIST (non-RoHS compliant)

SUZ-KA25VA.TH    SUZ-KA35VA.TH  
 SUZ-KA25VAH.TH    SUZ-KA35VAH.TH

## 14-2. OUTDOOR UNIT STRUCTURAL PARTS AND FUNCTIONAL PARTS

Part number that is circled is not shown in the illustration.

No.	Part No.	Part Name	Symbol in Wiring Diagram	Q'ty/unit				Remarks
				SUZ- KA25VA .TH	SUZ- KA25VAH .TH	SUZ- KA35VA .TH	SUZ- KA35VAH .TH	
1	E02 927 232	CABINET		1	1	1	1	
2	E02 927 521	GRILLE		1	1	1	1	
3	E02 927 501	PROPELLER FAN		1	1	1	1	
4	E02 927 290	BASE		1		1		
	E02 928 290	BASE			1		1	
5	E02 927 900	COMPRESSOR	MC	1	1			KNB073FDVH
	E02 929 900	COMPRESSOR	MC			1	1	KNB092FCAH
6	E02 065 506	COMPRESSOR RUBBER SET		3	3	3	3	3RUBBERS/SET
7	E02 927 661	STOP VALVE (GAS)		1	1	1	1	φ9.52
8	E02 927 662	STOP VALVE (LIQUID)		1	1	1	1	φ6.35
9	E02 927 245	SERVICE PANEL		1	1	1	1	
10	E02 927 233	BACK PANEL		1	1	1	1	
11	E02 927 640	EXPANSION VALVE		1	1			
	E02 838 640	EXPANSION VALVE				1	1	
12	E02 927 493	EXPANSION VALVE COIL	LEV	1	1	1	1	
13	E02 927 961	4-WAY VALVE		1	1	1	1	
14	E02 928 079	THERMO HOLDER			1			
	E02 930 079	THERMO HOLDER					1	
15	E02 928 525	CONDENSER WIRE NET			1			
	E02 930 525	CONDENSER WIRE NET					1	
16	E02 928 523	CONDENSER NET			1			
	E02 930 523	CONDENSER NET					1	
17	E02 838 523	CONDENSER NET		1				
	E02 929 523	CONDENSER NET				1		
18	E02 927 293	SEPARATOR		1				
	E02 928 293	SEPARATOR			1			
	E02 929 293	SEPARATOR				1		
	E02 930 293	SEPARATOR					1	
19	E02 927 515	MOTOR SUPPORT		1	1			
	E02 929 515	MOTOR SUPPORT				1	1	
20	E02 927 297	TOP PANEL		1	1	1	1	
21	E02 927 630	OUTDOOR HEAT EXCHANGER		1	1			
	E02 929 630	OUTDOOR HEAT EXCHANGER				1	1	
22	E02 927 301	OUTDOOR FAN MOTOR	MF	1	1	1	1	RC0J50-□□
23	E02 840 526	DEFROST HEATER	H		1		1	
24	E02 840 381	HEATER PROTECTOR	26H		1		1	
②5	E02 927 937	CAPILLARY TUBE		1	1			φ3.0×φ2.0×240
	E02 735 936	CAPILLARY TUBE				2	2	φ3.0×φ1.8×600

# PARTS LIST (non-RoHS compliant)

SUZ-KA50VA.TH SUZ-KA60VA.TH SUZ-KA71VA.TH

14-3. OUTDOOR UNIT STRUCTURAL PARTS, ELECTRICAL PARTS AND FUNCTIONAL PARTS

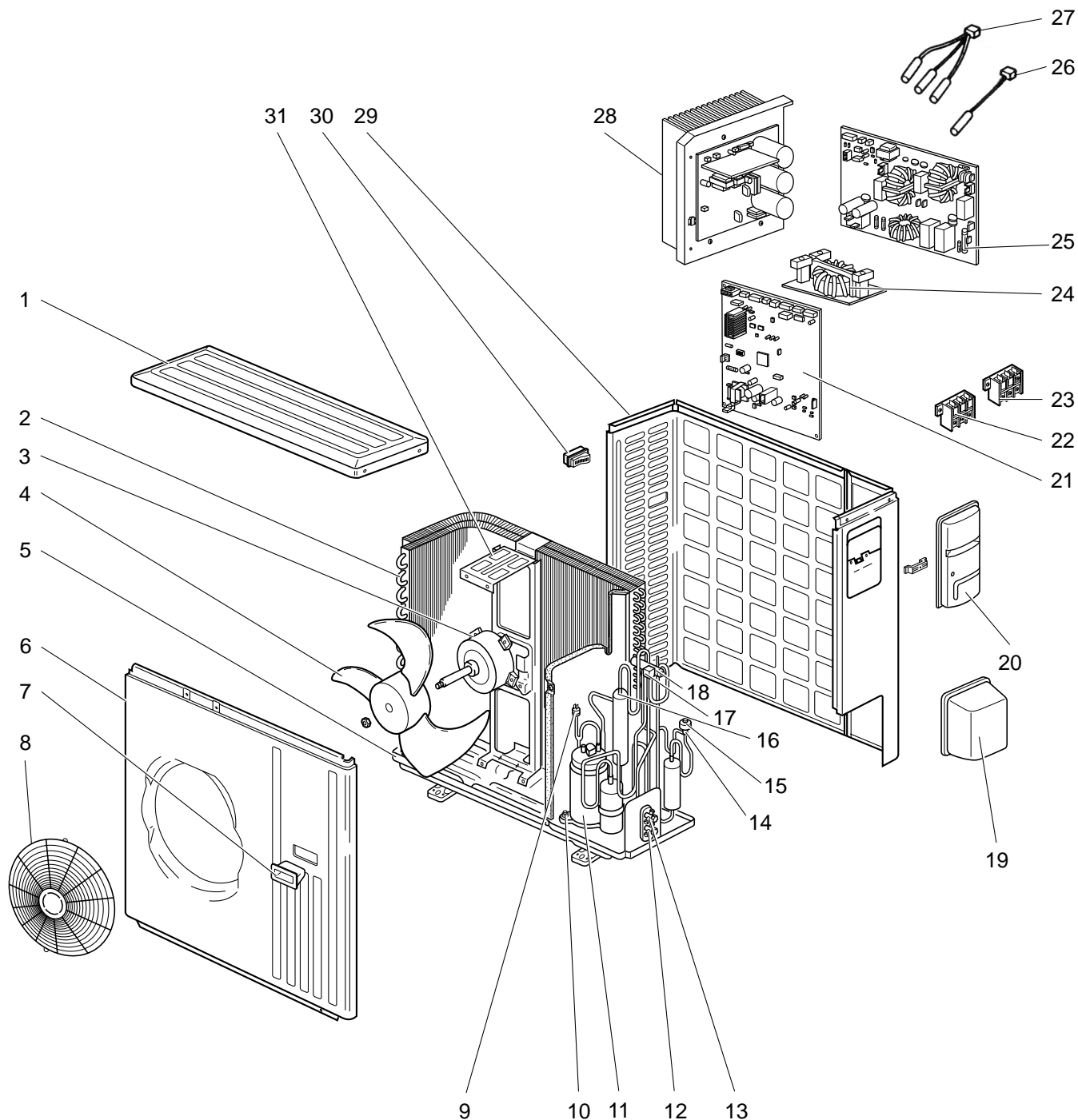

# PARTS LIST (non-RoHS compliant)

SUZ-KA50VA.TH SUZ-KA60VA.TH SUZ-KA71VA.TH

## 14-3. OUTDOOR UNIT STRUCTURAL PARTS, ELECTRICAL PARTS AND FUNCTIONAL PARTS

Part numbers that are circled are not shown in the illustration.

No.	Part No.	Part Name	Symbol in Wiring Diagram	Q'ty/unit			Remarks
				SUZ-KA•VA.TH			
				50	60	71	
1	E02 819 297	TOP PANEL		1	1	1	
2	E02 851 630	OUTDOOR HEAT EXCHANGER		1	1		
	E02 853 630	OUTDOOR HEAT EXCHANGER				1	
3	E02 938 301	OUTDOOR FAN MOTOR	MF	1	1	1	RC0J60-□□
4	E02 851 501	PROPELLER FAN		1	1	1	
5	E02 851 290	BASE		1	1		
	E02 853 290	BASE				1	
6	E02 819 232	CABINET		1	1	1	
7	E02 819 009	HANDLE		1	1	1	
8	E02 819 521	FAN GUARD		1	1	1	
9	E02 853 646	HIGH PRESSURE SWITCH	HPS			1	
10	E02 065 506	COMPRESSOR RUBBER SET		3	3		3RUBBERS/SET
	E02 853 506	COMPRESSOR RUBBER SET				3	3RUBBERS/SET
11	E02 939 900	COMPRESSOR	MC	1	1		SNB130FLDH1
	E02 853 900	COMPRESSOR	MC			1	TNB220FMCH
12	E02 851 661	STOP VALVE(GAS)		1			φ12.7
	E02 819 661	STOP VALVE(GAS)			1	1	φ15.88
13	E02 821 662	STOP VALVE(LIQUID)		1	1		φ6.35
	E02 822 662	STOP VALVE(LIQUID)				1	φ9.52
14	E02 851 640	EXPANSION VALVE		1	1		
	E02 853 640	EXPANSION VALVE				1	
15	E02 851 493	EXPANSION VALVE COIL	LEV	1	1	1	
16	E02 853 299	OIL SEPARATOR				1	
17	E02 935 490	R.V. COIL	21S4	1	1	1	
18	E02 891 961	4-WAY VALVE		1	1	1	
19	E02 819 650	VALVE COVER		1	1	1	
20	E02 819 245	SERVICE PANEL		1	1	1	
21	E07 170 450	OUTDOOR ELECTRONIC CONTROL P.C. BOARD		1			
	E07 171 450	OUTDOOR ELECTRONIC CONTROL P.C. BOARD			1		
	E07 223 450	OUTDOOR ELECTRONIC CONTROL P.C. BOARD				1	
22	E02 935 374	TERMINAL BLOCK	TB1	1	1	1	3P
23	E02 823 375	TERMINAL BLOCK	TB2	1	1	1	3P
24	E02 851 337	REACTOR	L	1	1	1	
25	E02 935 444	NOISE FILTER P.C. BOARD		1	1	1	
26	E02 935 309	AMBIENT TEMPERATURE THERMISTOR	RT65	1	1	1	
27	E02 851 308	THERMISTOR SET	RT61,RT62,RT68	1	1	1	DEFROST DISCHARGE OUTDOOR HEAT EXCHANGER
28	E02 935 440	POWER BOARD		1	1	1	Including heat sink and RT64
29	E02 819 233	BACK PANEL(OUT)		1	1	1	
30	E02 817 009	HANDLE		1	1	1	
31	E02 851 515	MOTOR SUPPORT		1	1	1	
③②	E02 127 382	FUSE	F801	1	1	1	250V/3.15A
③③	E02 737 382	FUSE	F911	1	1	1	250V/1A
③④	E02 935 385	FUSE & VARISTOR	F64,NR64	1	1	1	250V/2A
③⑤	E02 851 936	CAPILLARY TUBE(TAPER PIPE)		1	1		φ3.6xφ2.4x50
	E02 853 936	CAPILLARY TUBE(TAPER PIPE)				1	φ3.6xφ2.4x50
	E02 861 936	CAPILLARY TUBE				1	φ1.8xφ0.6x1000

# PARTS LIST (non-RoHS compliant)

SUZ-KA25VA.TH SUZ-KA35VA.TH

## 14-4. DRAIN SOCKET

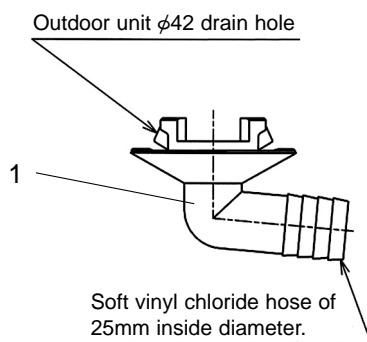

No.	Parts No.	Parts Name	Symbol in Wiring Diagram	Q'ty/unit		Remarks
				SUZ-KA25VA.TH	SUZ-KA35VA.TH	
1	E02 838 704	DRAIN SOCKET		1	1	

SUZ-KA50VA.TH

SUZ-KA60VA.TH

SUZ-KA71VA.TH

## 14-5. ACCESSORY

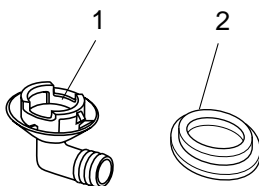

No.	Part No.	Part Name	Symbol in Wiring Diagram	Q'ty/unit			Remarks
				SUZ-KA50 VA.TH	SUZ-KA60 VA.TH	SUZ-KA71 VA.TH	
1	E02 817 704	DRAIN SOCKET		1	1	1	
2	E02 444 705	DRAIN CAP		2	2	2	$\phi 33$

SUZ-KA25VA.TH SUZ-KA35VA.TH  
 SUZ-KA25VAH.TH SUZ-KA35VAH.TH

### 15-1. OUTDOOR UNIT ELECTRICAL PARTS

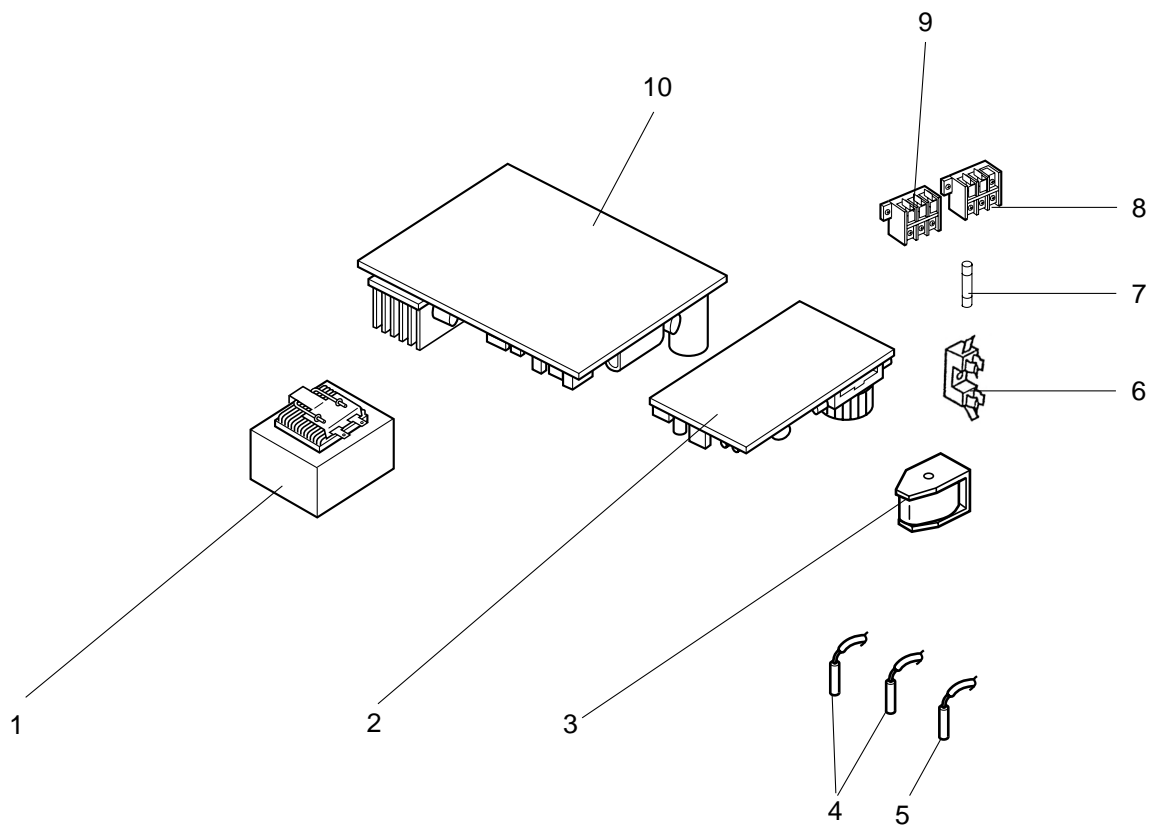

Part numbers that are circled are not shown in the illustration.

No.	RoHS	Part No.	Part Name	Symbol in Wiring Diagram	Q'ty/unit				Remarks
					SUZ- KA25VA .TH	SUZ- KA25VAH .TH	SUZ- KA35VA .TH	SUZ- KA35VAH .TH	
1	G	E12 838 337	REACTOR	L61	1	1	1	1	
2	G	E12 927 444	POWER P.C. BOARD		1		1		
	G	E12 931 444	POWER P.C. BOARD			1		1	
3	G	E12 927 490	R.V. COIL	21S4	1	1	1	1	
4	G	E12 927 306	THERMISTOR SET	RT61,RT62	1	1	1	1	DEFROST, DISCHARGE
5	G	E12 927 308	AMBIENT TEMPERATURE THERMISTOR	RT65	1	1	1	1	
6	G	E12 735 241	FUSE HOLDER		1	1	1	1	
7	G	E12 735 382	FUSE	F61	1	1	1	1	250V/20A
8	G	E12 573 375	TERMINAL BLOCK	TB1	1	1	1	1	3P
9	G	E12 927 374	TERMINAL BLOCK	TB2	1	1	1	1	3P
10	G	E17 168 451	INVERTER P.C. BOARD		1				Including heat sink and RT64
	G	E17 184 451	INVERTER P.C. BOARD			1			Including heat sink and RT64
	G	E17 169 451	INVERTER P.C. BOARD				1		Including heat sink and RT64
	G	E17 185 451	INVERTER P.C. BOARD					1	Including heat sink and RT64
⑪	G	E12 127 382	FUSE	F71,F801	1	1	1	1	250V/3.15A
⑫	G	E12 661 385	VARISTOR	NR62,NR63,NR64	1	1	1	1	

# RoHS PARTS LIST

SUZ-KA25VA.TH SUZ-KA35VA.TH  
SUZ-KA25VAH.TH SUZ-KA35VAH.TH

## 15-2. OUTDOOR UNIT STRUCTURAL PARTS AND FUNCTIONAL PARTS

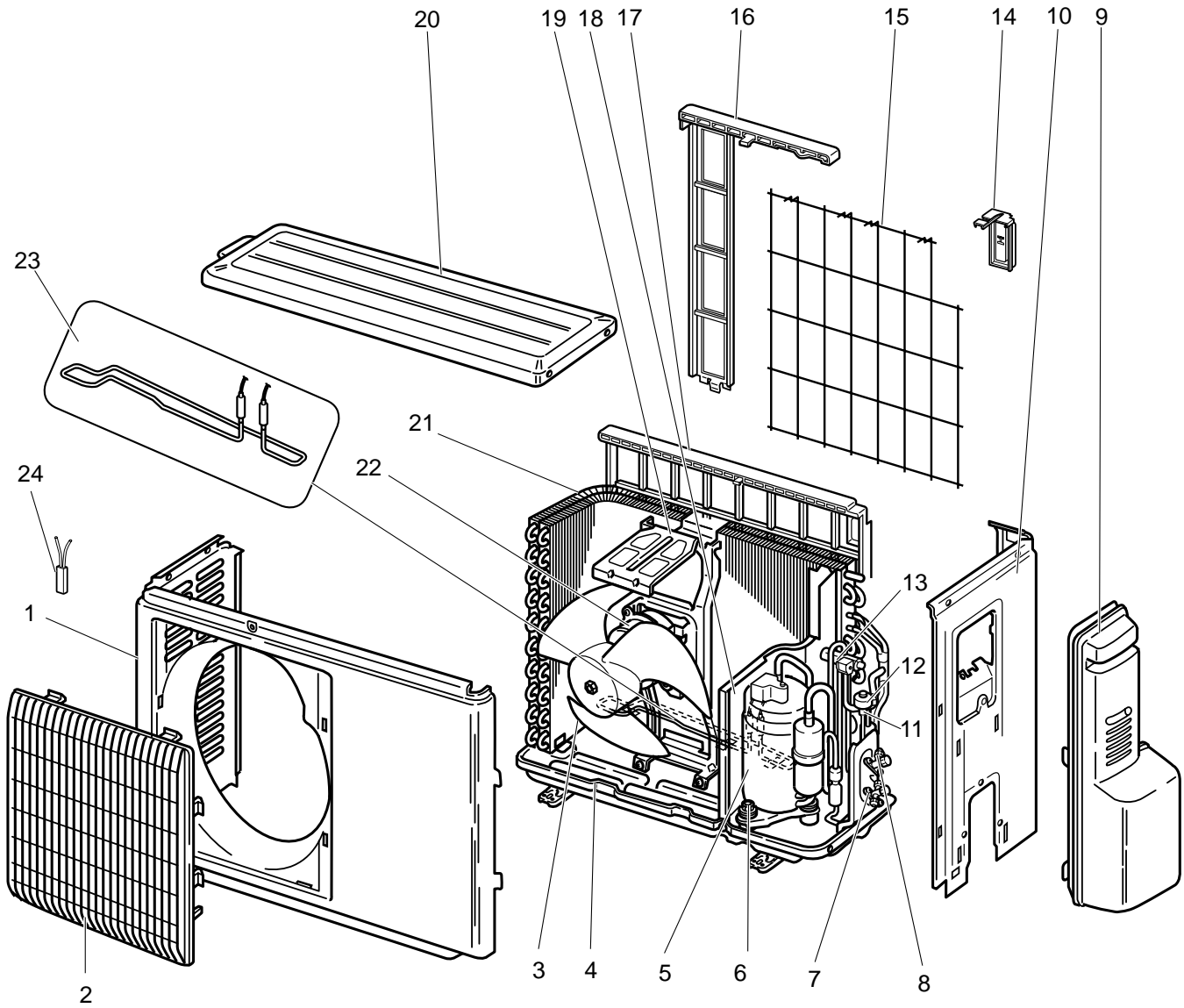



# RoHS PARTS LIST

SUZ-KA25VA.TH SUZ-KA35VA.TH  
 SUZ-KA25VAH.TH SUZ-KA35VAH.TH

## 15-2. OUTDOOR UNIT STRUCTURAL PARTS AND FUNCTIONAL PARTS

Part number that is circled is not shown in the illustration.

No.	ROHS	Part No.	Part Name	Symbol in Wiring Diagram	Q'ty/unit				Remarks
					SUZ- KA25VA .TH	SUZ- KA25VAH .TH	SUZ- KA35VA .TH	SUZ- KA35VAH .TH	
1	G	E12 927 232	CABINET		1	1	1	1	
2	G	E12 927 521	GRILLE		1	1	1	1	
3	G	E12 927 501	PROPELLER FAN		1	1	1	1	
4	G	E12 927 290	BASE		1		1		
	G	E12 928 290	BASE			1		1	
5	G	E12 927 900	COMPRESSOR	MC	1	1			KNB073FDVHC
	G	E12 929 900	COMPRESSOR	MC			1	1	KNB092FCAH
6	G	E12 065 506	COMPRESSOR RUBBER SET		3	3	3	3	3RUBBERS/SET
7	G	E12 927 661	STOP VALVE (GAS)		1	1	1	1	φ9.52
8	G	E12 927 662	STOP VALVE (LIQUID)		1	1	1	1	φ6.35
9	G	E12 927 245	SERVICE PANEL		1	1	1	1	
10	G	E12 927 233	BACK PANEL		1	1	1	1	
11	G	E12 927 640	EXPANSION VALVE		1	1			
	G	E12 838 640	EXPANSION VALVE				1	1	
12	G	E12 927 493	EXPANSION VALVE COIL	LEV	1	1	1	1	
13	G	E12 927 961	4-WAY VALVE		1	1	1	1	
14	G	E12 928 079	THERMO HOLDER			1			
	G	E12 930 079	THERMO HOLDER					1	
15	G	E12 928 525	CONDENSER WIRE NET			1			
	G	E12 930 525	CONDENSER WIRE NET					1	
16	G	E12 928 523	CONDENSER NET			1			
	G	E12 930 523	CONDENSER NET					1	
17	G	E12 838 523	CONDENSER NET		1				
	G	E12 929 523	CONDENSER NET				1		
18	G	E12 927 293	SEPARATOR		1				
	G	E12 928 293	SEPARATOR			1			
	G	E12 929 293	SEPARATOR				1		
	G	E12 930 293	SEPARATOR					1	
19	G	E12 927 515	MOTOR SUPPORT		1	1			
	G	E12 929 515	MOTOR SUPPORT				1	1	
20	G	E12 927 297	TOP PANEL		1	1	1	1	
21	G	E12 927 630	OUTDOOR HEAT EXCHANGER		1	1			
	G	E12 929 630	OUTDOOR HEAT EXCHANGER				1	1	
22	G	E12 927 301	OUTDOOR FAN MOTOR	MF	1	1	1	1	RC0J50-□□
23	G	E12 840 526	DEFROST HEATER	H		1		1	
24	G	E12 840 381	HEATER PROTECTOR	26H		1		1	
②5	G	E12 927 937	CAPILLARY TUBE		1	1			φ3.0×φ2.0×240
	G	E12 735 936	CAPILLARY TUBE				2	2	φ3.0×φ1.8×600

# RoHS PARTS LIST

SUZ-KA25VAR1.TH    SUZ-KA35VAR1.TH  
SUZ-KA25VAHR1.TH    SUZ-KA35VAHR1.TH  
15-3. OUTDOOR UNIT ELECTRICAL PARTS

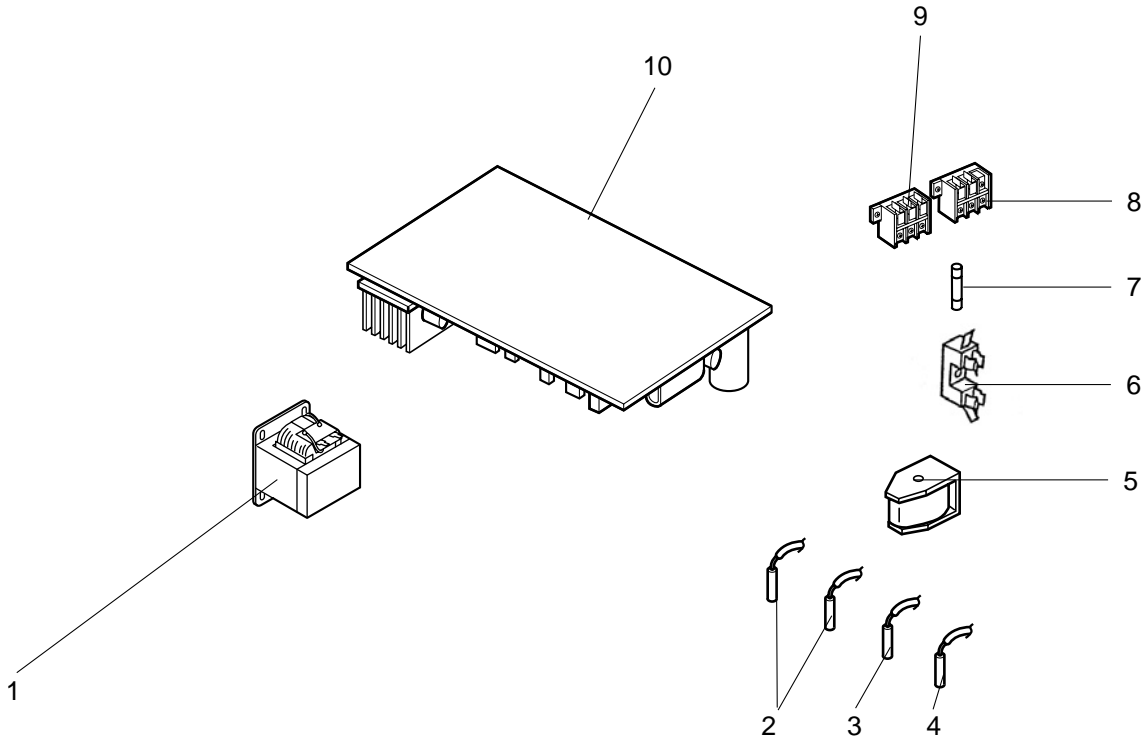

# RoHS PARTS LIST

SUZ-KA25VAR1.TH SUZ-KA35VAR1.TH  
 SUZ-KA25VAHR1.TH SUZ-KA35VAHR1.TH

## 15-3. OUTDOOR UNIT ELECTRICAL PARTS

Part numbers that are circled are not shown in the illustration.

No.	RoHS	Part No.	Part Name	Symbol in Wiring Diagram	Q'ty/unit				Remarks
					SUZ-KA-VAR1.TH		SUZ-KA-VAHR1.TH		
					25	35	25	35	
1	G	E12 838 337	REACTOR	L61	1	1	1	1	
2	G	E12 C34 306	THERMISTOR SET	RT61,RT62	1	1	1	1	DEFROST, DISCHARGE
3	G	E12 927 308	AMBIENT TEMPERATURE THERMISTOR	RT65	1	1	1	1	
4	G	E12 C34 307	OUTDOOR HEAT EXCHANGER TEMPERATURE THERMISTOR	RT68	1	1	1	1	
5	G	E12 C34 490	R.V. COIL	21S4	1	1	1	1	
6	G	E12 735 241	FUSE HOLDER		1	1	1	1	
7	G	E12 735 382	FUSE	F61	1	1	1	1	T20AL250V
8	G	E12 D69 374	TERMINAL BLOCK	TB1	1	1	1	1	3P
9	G	E12 D70 374	TERMINAL BLOCK	TB2	1	1	1	1	3P
10	G	E17 573 451	INVERTER P.C. BOARD		1				Including heat sink and RT64
	G	E17 574 451	INVERTER P.C. BOARD			1			
	G	E17 575 451	INVERTER P.C. BOARD				1		
	G	E17 576 451	INVERTER P.C. BOARD					1	
⑪	G	E12 784 382	FUSE	F701,F801,F901	1	1	1	1	T3.15AL 250V
⑫	G	E12 661 385	VARISTOR	NR61-NR64	1	1	1	1	

# RoHS PARTS LIST

SUZ-KA25VAR1.TH    SUZ-KA35VAR1.TH  
SUZ-KA25VAHR1.TH    SUZ-KA35VAHR1.TH

## 15-4. OUTDOOR UNIT UNIT STRUCTURAL PARTS AND FUNCTIONAL PARTS

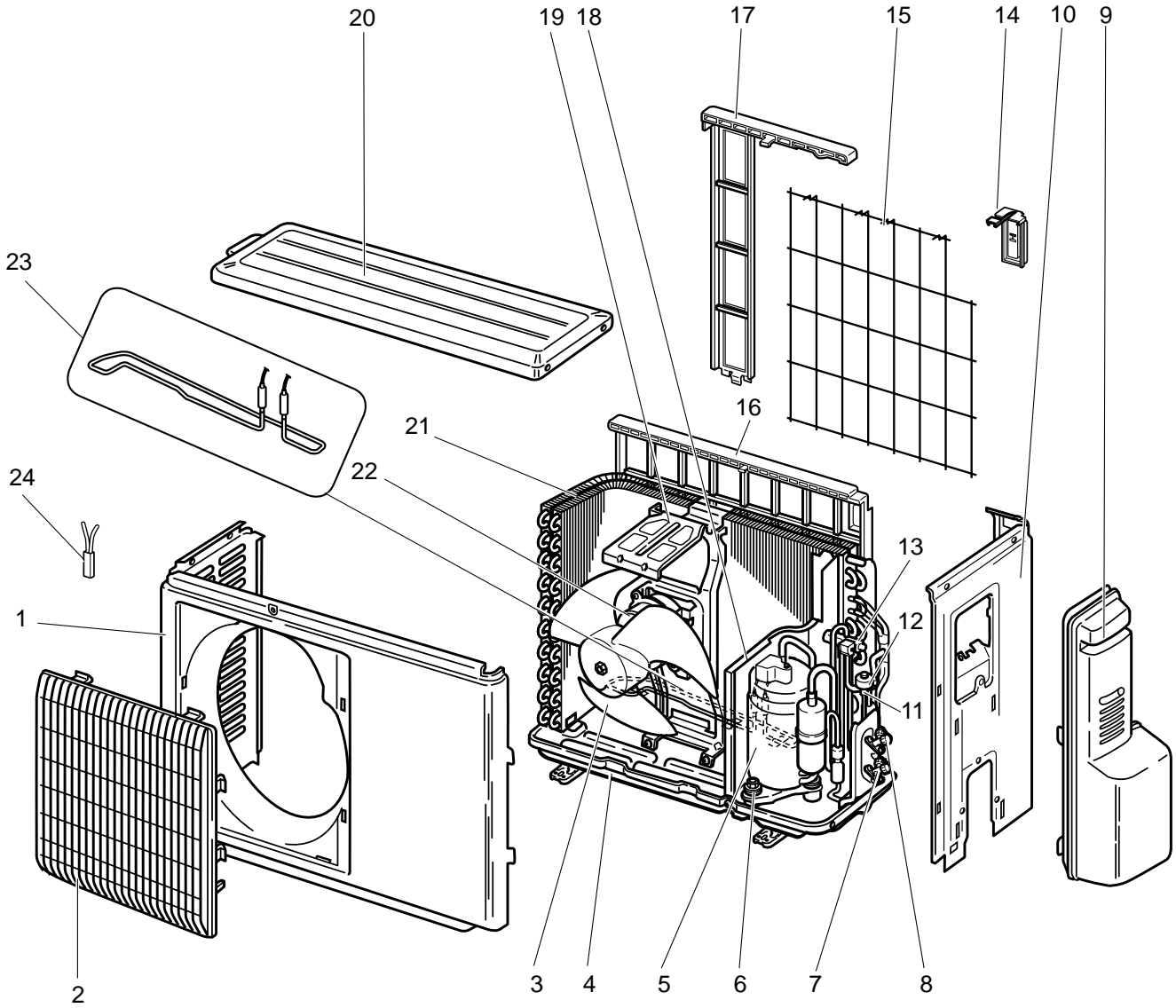

# RoHS PARTS LIST

SUZ-KA25VAR1.TH SUZ-KA35VAR1.TH  
 SUZ-KA25VAHR1.TH SUZ-KA35VAHR1.TH

## 15-4. OUTDOOR UNIT UNIT STRUCTURAL PARTS AND FUNCTIONAL PARTS

Part numbers that are circled are not shown in the illustration.

No.	RoHS	Part No.	Part Name	Symbol in Wiring Diagram	Q'ty/unit				Remarks
					SUZ-KA-VAR1.TH		SUZ-KA-VAHR1.TH		
					25	35	25	35	
1	G	E12 927 232	CABINET		1	1	1	1	
2	G	E12 927 521	GRILLE		1	1	1	1	
3	G	E12 927 501	PROPELLER		1	1	1	1	
4	G	E12 D69 290	BASE		1	1			
	G	E12 D70 290	BASE				1	1	
5	G	E12 D69 900	COMPRESSOR	MC	1		1		KNB073FFDHC
	G	E12 D70 900	COMPRESSOR	MC		1		1	KNB092FFAHC
6	G	E12 065 506	COMPRESSOR RUBBER SET		3	3	3	3	3 RUBBERS/SET
7	G	E12 D69 661	STOP VALVE (GAS)		1	1	1	1	∅9.52
8	G	E12 D58 662	STOP VALVE (LIQUID)		1	1	1	1	∅6.35
9	G	E12 927 245	SERVICE PANEL		1	1	1	1	
10	G	E12 927 233	BACK PANEL		1	1	1	1	
11	G	E12 927 640	EXPANSION VALVE		1	1	1	1	
12	G	E12 927 493	EXPANSION VALVE COIL	LEV	1	1	1	1	
13	G	E12 D65 961	4-WAY VALVE		1	1	1	1	
14	G	E12 928 079	THERMO HOLDER				1		
	G	E12 930 079	THERMO HOLDER					1	
15	G	E12 928 525	CONDENSER WIRE NET				1		
	G	E12 930 525	CONDENSER WIRE NET					1	
16	G	E12 B83 523	CONDENSER NET		1				
	G	E12 929 523	CONDENSER NET			1			
17	G	E12 928 523	CONDENSER NET				1		
	G	E12 930 523	CONDENSER NET					1	
18	G	E12 D69 293	SEPARATOR		1				
	G	E12 C34 293	SEPARATOR			1			
	G	E12 D77 293	SEPARATOR				1		
	G	E12 C36 293	SEPARATOR					1	
19	G	E12 927 515	MOTOR SUPPORT		1		1		
	G	E12 929 515	MOTOR SUPPORT			1		1	
20	G	E12 927 297	TOP PANEL		1	1	1	1	
21	G	E12 D69 630	OUTDOOR HEAT EXCHANGER		1		1		
	G	E12 D70 630	OUTDOOR HEAT EXCHANGER			1		1	
22	G	E12 D69 301	OUTDOOR FAN MOTOR	MF	1	1	1	1	RC0J50-□□
23	G	E12 C36 526	DEFROST HEATER	H			1	1	
24	G	E12 C36 381	HEATER PROTECTOR	26H			1	1	
②⑤	G	E12 927 937	CAPILLARY TUBE		1	1	1	1	∅3.0 × ∅2.0 × 240
②⑥	G	E12 735 936	CAPILLARY TUBE			2		2	∅3.0 × ∅1.8 × 600

# RoHS PARTS LIST

SUZ-KA50VA.TH SUZ-KA60VA.TH SUZ-KA71VA.TH  
 SUZ-KA50VA<sub>1</sub>.TH SUZ-KA60VA<sub>1</sub>.TH SUZ-KA71VA<sub>1</sub>.TH  
 SUZ-KA60VAR2.TH

## 15-5. OUTDOOR UNIT STRUCTURAL PARTS, ELECTRICAL PARTS AND FUNCTIONAL PARTS

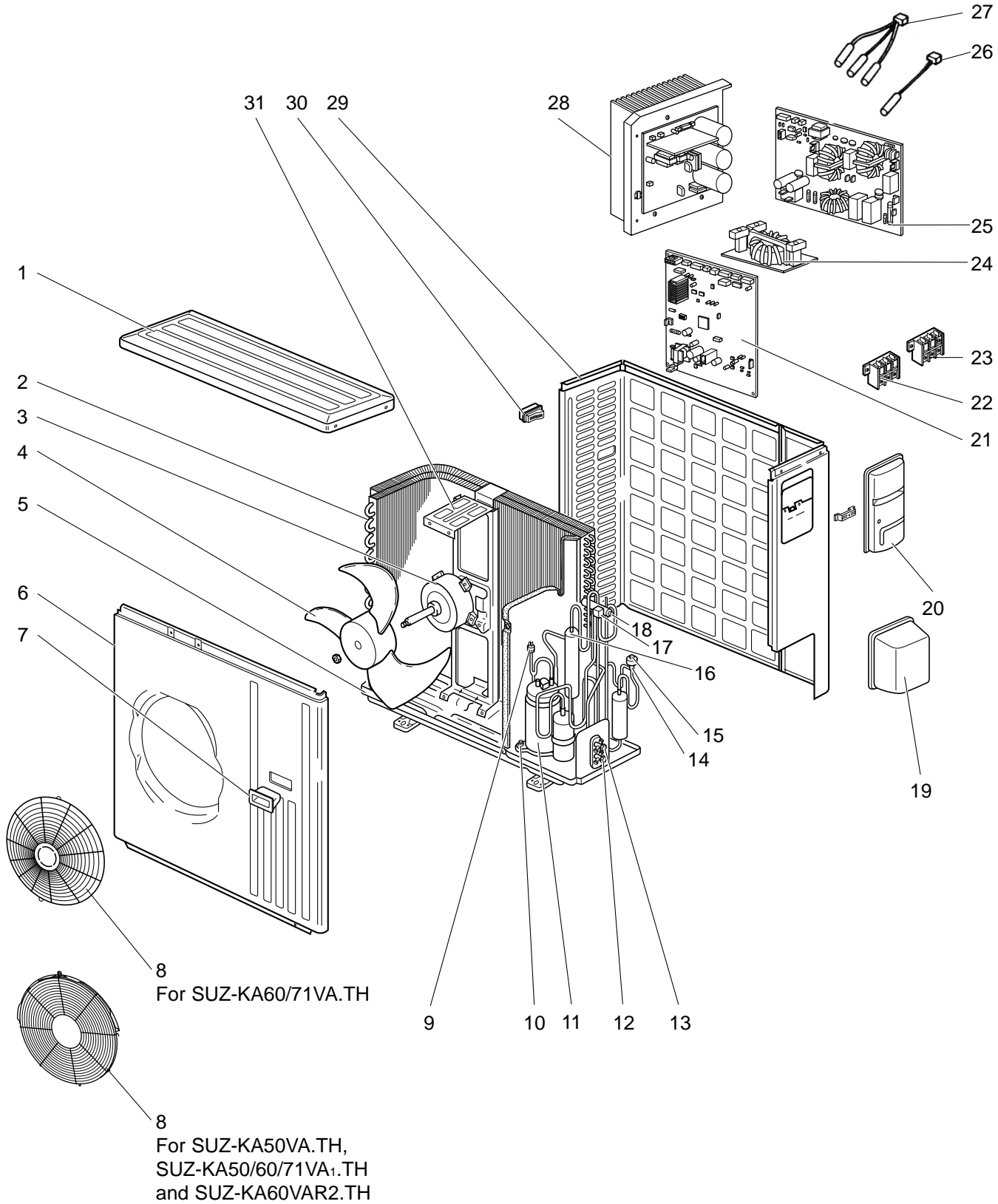

# RoHS PARTS LIST

Part numbers that are circled are not shown in the illustration.

No.	RoHS	Part No.	Part Name	Symbol in Wiring Diagram	Q'ty/unit								Remarks
					SUZ-KA*VA.TH			SUZ-KA*VA <sub>1</sub> .TH			SUZ-KA* VAR2.TH		
					50	60	71	50	60	71	60		
1	G	E12 819 297	TOP PANEL		1	1	1	1	1	1	1		
2	G	E12 851 630	OUTDOOR HEAT EXCHANGER		1	1		1	1		1		
	G	E12 853 630	OUTDOOR HEAT EXCHANGER				1			1			
3	G	E12 938 301	OUTDOOR FAN MOTOR	MF	1	1	1	1	1	1	1	RC0J60- □□	
4	G	E12 851 501	PROPELLER FAN		1	1	1	1	1	1	1		
5	G	E12 851 290	BASE		1	1		1	1		1		
	G	E12 853 290	BASE				1			1			
6	G	E12 819 232	CABINET		1	1	1	1	1	1	1		
7	G	E12 819 009	HANDLE		1	1	1	1	1	1	1		
8	G	E12 819 521	FAN GUARD			1	1						
	G	E12 D84 521	FAN GUARD		1			1	1	1	1		
9	G	E12 853 646	HIGH PRESSURE SWITCH	HPS			1			1	1		
10	G	E12 065 506	COMPRESSOR RUBBER SET		3	3		3	3			3RUBBERS/SET	
	G	E12 853 506	COMPRESSOR RUBBER SET				3			3		3RUBBERS/SET	
	G	E12 C34 506	COMPRESSOR RUBBER SET								3	3RUBBERS/SET	
11	G	E12 939 900	COMPRESSOR	MC	1	1		1	1			SNB130FLDH1	
	G	E12 853 900	COMPRESSOR	MC			1			1		TNB220FMCHT	
	G	E12 C37 900	COMPRESSOR	MC							1	SNB130FGBH	
12	G	E12 851 661	STOP VALVE(GAS)		1			1				φ12.7	
	G	E12 819 661	STOP VALVE(GAS)			1	1		1	1	1	φ15.88	
13	G	E12 821 662	STOP VALVE(LIQUID)		1	1		1	1		1	φ6.35	
	G	E12 822 662	STOP VALVE(LIQUID)				1			1		φ9.52	
14	G	E12 851 640	EXPANSION VALVE		1	1		1	1		1		
	G	E12 853 640	EXPANSION VALVE				1			1			
15	G	E12 851 493	EXPANSION VALVE COIL	LEV	1	1	1	1	1	1	1		
16	G	E12 853 299	OIL SEPARATOR				1			1			
17	G	E12 935 490	R.V. COIL	21S4	1	1	1	1	1	1			
	G	E12 D02 490	R.V. COIL	21S4							1		
18	G	E12 891 961	4-WAY VALVE		1	1	1	1	1	1			
	G	E12 C18 961	4-WAY VALVE								1		
19	G	E12 819 650	VALVE COVER		1	1	1	1	1	1	1		
20	G	E12 819 245	SERVICE PANEL		1	1	1	1	1	1	1		
21	G	E17 170 450	OUTDOOR ELECTRONIC CONTROL P.C. BOARD		1								
	G	E17 171 450	OUTDOOR ELECTRONIC CONTROL P.C. BOARD			1							
	G	E17 223 450	OUTDOOR ELECTRONIC CONTROL P.C. BOARD				1						
	G	E17 313 450	OUTDOOR ELECTRONIC CONTROL P.C. BOARD					1					
	G	E17 314 450	OUTDOOR ELECTRONIC CONTROL P.C. BOARD						1				
	G	E17 315 450	OUTDOOR ELECTRONIC CONTROL P.C. BOARD							1			
22	G	E12 823 375	TERMINAL BLOCK	TB2	1	1	1	1	1	1		3P	
	G	E12 D69 374	TERMINAL BLOCK	TB2							1	3P	
23	G	E12 935 374	TERMINAL BLOCK	TB1	1	1	1	1	1	1	1	3P	
24	G	E12 851 337	REACTOR	L	1	1	1	1	1	1	1		
25	G	E12 935 444	NOISE FILTER P.C. BOARD		1	1	1	1	1	1	1		
26	G	E12 935 309	AMBIENT TEMPERATURE THERMISTOR	RT65	1	1	1	1	1	1	1		
27	G	E12 851 308	THERMISTOR SET	RT61,RT62,RT68	1	1	1	1	1	1	1	DEFROST, DISCHARGE OUTDOOR HEAT EXCHANGER	
28	G	E12 935 440	POWER BOARD		1	1	1	1	1	1		Including heatsink and RT64	
	G	E12 B79 440	POWER BOARD								1	Including heatsink and RT64	
29	G	E12 819 233	BACK PANEL(OUT)		1	1	1	1	1	1			
	G	E12 D58 233	BACK PANEL(OUT)								1		
30	G	E12 817 009	HANDLE		1	1	1	1	1	1	1		
31	G	E12 851 515	MOTOR SUPPORT		1	1	1	1	1	1	1		
32	G	E12 127 382	FUSE	F801	1	1	1	1	1	1		250V/3.15A	
	G	E12 784 382	FUSE	F801							1	250V/3.15A	
33	G	E12 737 382	FUSE	F911	1	1	1	1	1	1		250V/1A	
	G	E12 B79 382	FUSE	F911							1	250V/1A	
34	G	E12 935 385	FUSE & VARISTOR	F64,NR64	1	1	1	1	1	1		250V/2A	
	G	E12 977 385	FUSE & VARISTOR	F64,NR64							1	250V/2A	
35	G	E12 851 936	CAPILLARY TUBE(TAPER PIPE)		1	1		1	1		1	φ3.6xφ2.4x50	
	G	E12 853 936	CAPILLARY TUBE(TAPER PIPE)				1			1		φ3.6xφ2.4x50	
	G	E12 861 936	CAPILLARY TUBE				1			1		φ1.8xφ0.6x1000	

# RoHS PARTS LIST

SUZ-KA50VAR2.TH

## 15-6. OUTDOOR UNIT STRUCTURAL PARTS, ELECTRICAL PARTS AND FUNCTIONAL PARTS

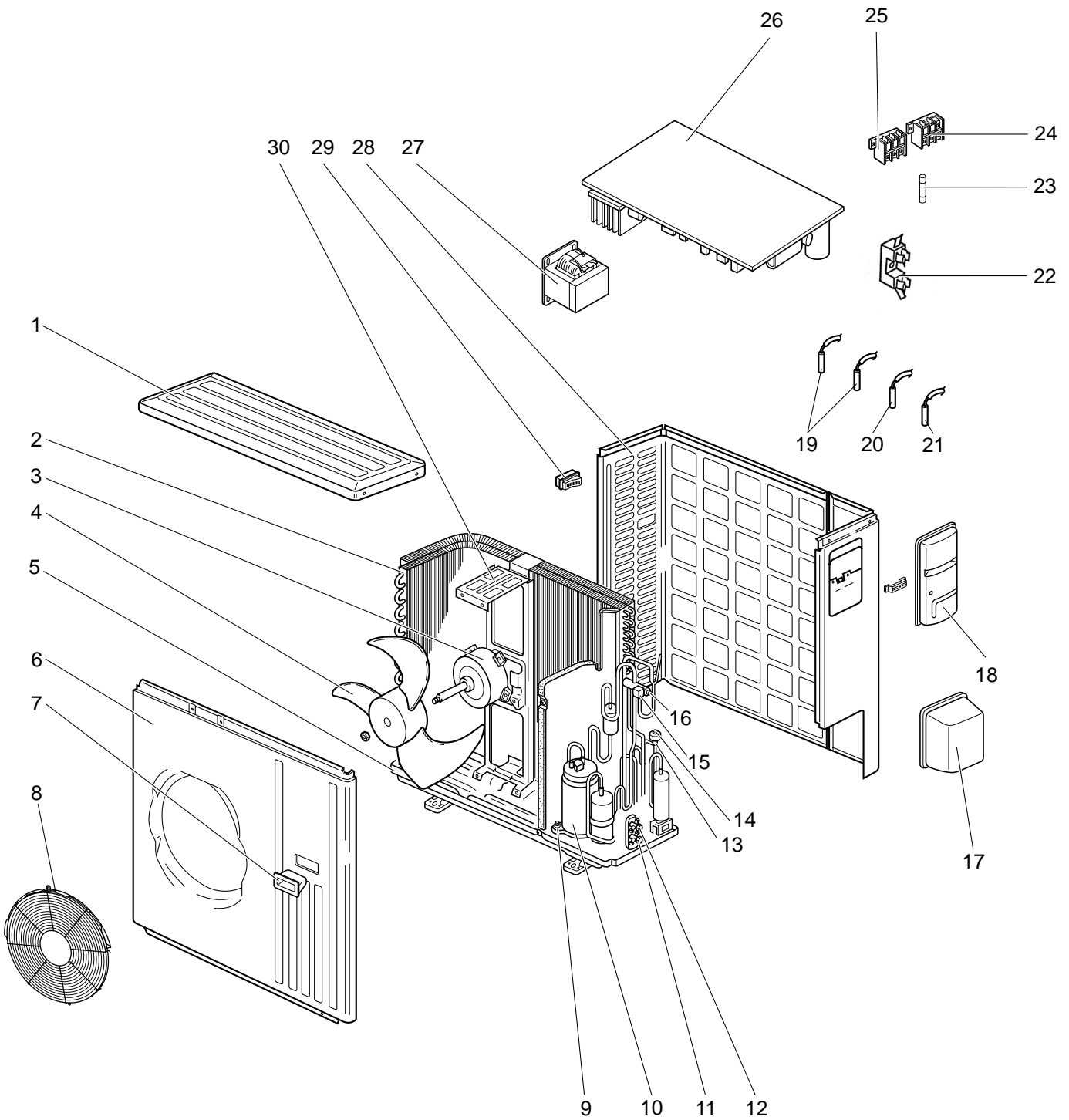



# RoHS PARTS LIST

## 15-6. OUTDOOR UNIT STRUCTURAL PARTS, ELECTRICAL PARTS AND FUNCTIONAL PARTS

Part numbers that are circled are not shown in the illustration.

No.	RoHS	Part No.	Part Name	Symbol in Wiring Diagram	Q'ty/unit	Remarks
					SUZ-KA50VAR2.TH	
1	G	E12 819 297	TOP PANEL		1	
2	G	E12 851 630	OUTDOOR HEAT EXCHANGER		1	
3	G	E12 938 301	OUTDOOR FAN MOTOR	MF	1	RC0J60-□□
4	G	E12 851 501	PROPELLER FAN		1	
5	G	E12 851 290	BASE		1	
6	G	E12 819 232	CABINET		1	
7	G	E12 819 009	HANDLE		1	
8	G	E12 D84 521	FAN GUARD		1	
9	G	E12 C34 506	COMPRESSOR RUBBER SET		3	3 RUBBERS/SET
10	G	E12 C37 900	COMPRESSOR	MC	1	SNB130FGBH
11	G	E12 D58 661	STOP VALVE (GAS)		1	∅12.7
12	G	E12 D58 662	STOP VALVE (LIQUID)		1	∅6.35
13	G	E12 851 640	EXPANSION VALVE		1	
14	G	E12 D58 493	EXPANSION VALVE COIL	LEV	1	
15	G	E12 D58 490	R.V. COIL	21S4	1	
16	G	E12 C18 961	4-WAY VALVE		1	
17	G	E12 819 650	VALVE COVER		1	
18	G	E12 819 245	SERVICE PANEL		1	
19	G	E12 D58 306	THERMISTOR SET	RT61,RT62	1	DEFROST, DISCHARGE
20	G	E12 D58 309	AMBIENT TEMPERATURE THERMISTOR	RT65	1	
21	G	E12 C34 307	OUTDOOR HEAT EXCHANGER TEMPERATURE THERMISTOR	RT68	1	
22	G	E12 735 241	FUSE HOLDER		1	
23	G	E12 735 382	FUSE	F61	1	T20AL250V
24	G	E12 927 374	TERMINAL BLOCK	TB1	1	3 P
25	G	E12 D69 374	TERMINAL BLOCK	TB2	1	3 P
26	G	E12 524 451	INVERTER P.C. BOARD		1	Including heatsink and RT64
27	G	E12 D58 337	REACTOR	L61	1	
28	G	E12 D58 233	BACK PANEL (OUT)		1	
29	G	E12 817 009	HANDLE		1	
30	G	E12 851 515	MOTOR SUPPORT		1	
③1	G	E12 851 936	CAPILLARY TUBE (TAPER PIPE)		1	∅3.6 × ∅2.4 × 50
③2	G	E12 784 382	FUSE	F801	1	T3.15AL250V
③3	G	E12 661 385	VARISTOR	NR61-64	1	

# RoHS PARTS LIST

SUZ-KA25VA.TH SUZ-KA35VA.TH SUZ-KA25VAR1.TH SUZ-KA35VAR1.TH  
 SUZ-KA25VAH.TH SUZ-KA35VAH.TH SUZ-KA25VAHR1.TH SUZ-KA35VAHR1.TH  
 15-8. DRAIN SOCKET

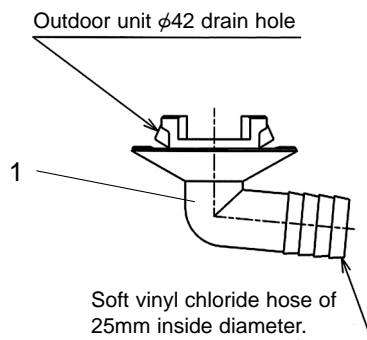

No.	RoHS	Parts No.	Parts Name	Symbol in Wiring Diagram	Q'ty/unit				Remarks
					SUZ-KA				
					25VA.TH	25VAH.TH	35VA.TH	35VAH.TH	
					25VAR1.TH	25VAHR1.TH	35VAR1.TH	35VAHR1.TH	
1	G	E12 838 704	DRAIN SOCKET		1		1		

SUZ-KA50VA.TH SUZ-KA50VA<sub>1</sub>.TH SUZ-KA50VAR2.TH  
 SUZ-KA60VA.TH SUZ-KA60VA<sub>1</sub>.TH SUZ-KA60VAR2.TH  
 SUZ-KA71VA.TH SUZ-KA71VA<sub>1</sub>.TH  
 15-9. ACCESSORY

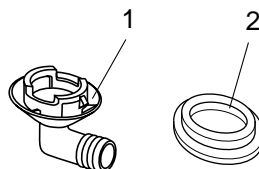

No.	RoHS	Part No.	Part Name	Symbol in Wiring Diagram	Q'ty/unit			Remarks
					SUZ-KA50/60		SUZ-KA71	
					VA <sub>(t)</sub> .TH	VAR2.TH	VA <sub>(t)</sub> .TH	
1	G	E12 817 704	DRAIN SOCKET		1	1	1	
2	G	E12 444 705	DRAIN CAP		2	2	2	φ33, 2PCS/SET

## MITSUBISHI ELECTRIC CORPORATION

HEAD OFFICE: TOKYO BLDG., 2-7-3, MARUNOUCHI, CHIYODA-KU, TOKYO100-8310, JAPAN

©Copyright 2005 MITSUBISHI ELECTRIC CORPORATION  
 Distributed in May 2012 No.OC322 REVISED EDITION-H  
 Distributed in Aug. 2011 No.OC322 REVISED EDITION-G  
 Distributed in Oct. 2009 No.OC322 REVISED EDITION-F PDF 6  
 Distributed in Apr. 2009 No.OC322 REVISED EDITION-E PDF 6  
 Distributed in Nov. 2008 No.OC322 REVISED EDITION-D PDF 6  
 Distributed in Mar. 2007 No.OC322 REVISED EDITION-C PDF 7  
 Distributed in Oct. 2006 No.OC322 REVISED EDITION-B PDF 7  
 Distributed in Oct. 2005 No.OC322 REVISED EDITION-A PDF 8  
 Distributed in Apr. 2005 No.OC322 PDF 8  
 Made in Japan

New publication, effective May 2012  
 Specifications are subject to change without notice.