

SERVICE MANUAL

Series PLA Ceiling Cassettes R407C/R410A

 Indoor unit
 [Model names]

PLA-RP100AA2

PLA-RP125AA2

PLA-RP140AA2

[Service Ref.]

PLA-RP100AA2.UK
PLA-RP125AA2.UK
PLA-RP140AA2.UK

Revision:

- RoHS PARTS LIST is added.
- Some descriptions have been modified.

- Please void OC357.

Note:

- This manual describes only service data of the indoor units.
- RoHS compliant products have <G> mark on the spec name plate.
- For servicing of RoHS compliant products, refer to the RoHS Parts List.

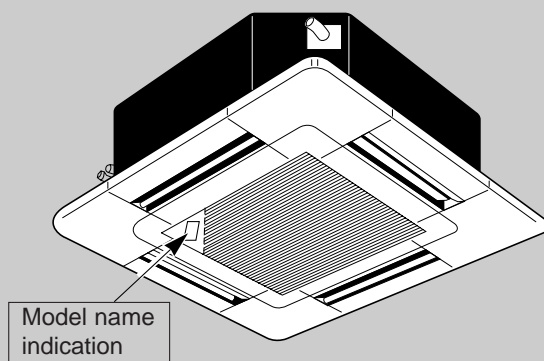

INDOOR UNIT

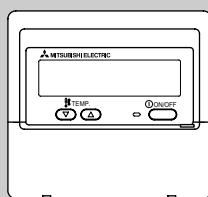
 WIRELESS REMOTE
 CONTROLLER

 WIRED REMOTE
 CONTROLLER

CONTENTS

1. REFERENCE MANUAL	2
2. SAFETY PRECAUTION	2
3. PART NAMES AND FUNCTIONS	6
4. SPECIFICATIONS	9
5. NOISE CRITERION CURVES	10
6. OUTLINES AND DIMENSIONS	11
7. WIRING DIAGRAM.....	12
8. REFRIGERANT SYSTEM DIAGRAM	13
9. TROUBLESHOOTING	14
10. DISASSEMBLY PROCEDURE	31
11. PARTS LIST	34
12. RoHS PARTS LIST	37

1 REFERENCE MANUAL

1-1. OUTDOOR UNIT'S SERVICE MANUAL

Service Ref.	Service Manual No.
PUHZ-RP100/125/140VHA ⁽¹⁾ PUHZ-RP100/125/140YHA ⁽¹⁾	OC334
PUHZ-RP200/250YHA ⁽¹⁾	OC338
PU(H)-P.VGAA.UK PU(H)-P.YGAA.UK	OC336
SUZ-KA.VA.TH	OC322
PUHZ-RP100/125/140VHA2 PUHZ-RP100/125/140YHA2	OC374
PU(H)-P100VHA.UK PU(H)-P100/125/140YHA.UK	OC379
PUHZ-P100/125/140VHA.UK	OC359

1-2. TECHNICAL DATA BOOK

Series (Outdoor unit)	Manual No.
PUHZ-RP.VHA(-A) PUHZ-RP.YHA(-A)	OCS01
PU(H)-P.VGAA.UK PU(H)-P.YGAA.UK	OCS02
PUHZ-RP.VHA2 PUHZ-RP.YHA2	OCS05
PUHZ-P.VHA	OCS06
PU(H)-P.VHA PU(H)-P.YHA	OCS07

2 SAFETY PRECAUTION

CAUTIONS RELATED TO NEW REFRIGERANT

Cautions for units utilising refrigerant R407C

Do not use the existing refrigerant piping.

The old refrigerant and lubricant in the existing piping contains a large amount of chlorine which may cause the lubricant deterioration of the new unit.

Use "low residual oil piping"

If there is a large amount of residual oil (hydraulic oil, etc.) inside the piping and joints, deterioration of the lubricant will result.

Store the piping to be used during installation indoors with keep both ends sealed until just before brazing. (Store elbows and other joints in a plastic bag.)

If dust, dirt, or water enters the refrigerant cycle, deterioration of the oil and compressor trouble may result.

Use ESTER , ETHER or HAB as the lubricant to coat flares and flange connection parts.

If large amount of mineral oil enter, that can cause deterioration of refrigerant oil etc.

Use liquid refrigerant to charge the system.

If gas refrigerant is used to seal the system, the composition of the refrigerant in the cylinder will change and performance may drop.

Do not use a refrigerant other than R407C.

If another refrigerant (R22, etc.) is used, the chlorine in the refrigerant may cause the lubricant deterioration.

Use a vacuum pump with a reverse flow check valve.

The vacuum pump oil may flow back into the refrigerant cycle and cause the lubricant deterioration.

Ventilate the room if refrigerant leaks during operation. If refrigerant comes into contact with a flame, poisonous gases will be released.

[1] Cautions for service

- After recovering the all refrigerant in the unit, proceed to working.
- Do not release refrigerant in the air.
- After completing the repair service, recharge the cycle with the specified amount of liquid refrigerant.

[2] Refrigerant recharging

(1) Refrigerant recharging process

- ① Direct charging from the cylinder.
- R407C cylinder are available on the market has a syphon pipe.
 - Leave the syphon pipe cylinder standing and recharge it.
- (By liquid refrigerant)

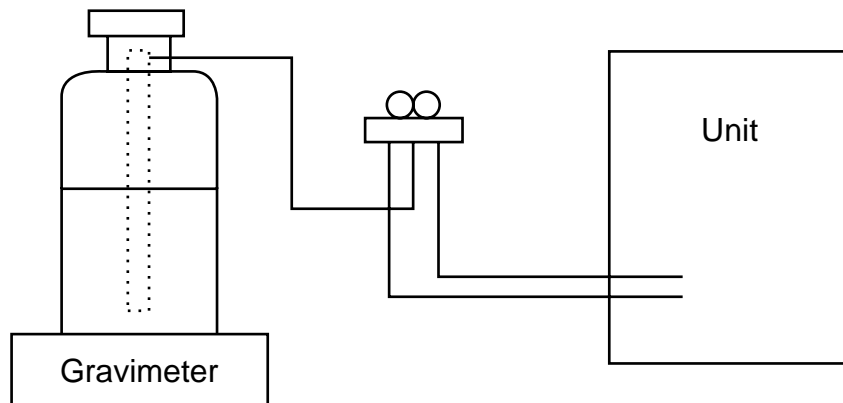

(2) Recharge in refrigerant leakage case

- After recovering the all refrigerant in the unit, proceed to working.
- Do not release the refrigerant in the air.
- After completing the repair service, recharge the cycle with the specified amount of liquid refrigerant.

[3] Service tools

Use the below service tools as exclusive tools for R407C refrigerant.

No.	Tool name	Specifications
①	Gauge manifold	·Only for R407C.
		·Use the existing fitting SPECIFICATIONS. (UNF7/16)
		·Use high-tension side pressure of 3.43MPa-G or over.
②	Charge hose	·Only for R407C.
		·Use pressure performance of 5.10MPa-G or over.
③	Electronic scale	
④	Gas leak detector	·Use the detector for R134a or R407C.
⑤	Adapter for reverse flow check.	·Attach on vacuum pump.
⑥	Refrigerant charge base.	
⑦	Refrigerant cylinder.	·For R407C ·Top of cylinder (Brown)
		·Cylinder with syphon
⑧	Refrigerant recovery equipment.	

CAUTIONS RELATED TO NEW REFRIGERANT

Caution for units utilising refrigerant R410A

Use new refrigerant pipes.

In case of using the existing pipes for R22, be careful with the followings.

- For RP100, 125 and 140, be sure to perform replacement operation before test run.
- Change flare nut to the one provided with this product. Use a newly flared pipe.
- Avoid using thin pipes.

Make sure that the inside and outside of refrigerant piping is clean and it has no contamination such as sulfur hazardous for use, oxides, dirt, shaving particles, etc. In addition, use pipes with specified thickness.

Contamination inside refrigerant piping can cause deterioration of refrigerant oil etc.

Store the piping to be used during installation indoors and keep both ends of the piping sealed until just before brazing. (Leave elbow joints, etc. in their packaging.)

If dirt, dust or moisture enter into refrigerant cycle, that can cause deterioration of refrigerant oil or malfunction of compressor.

Use ester oil, ether oil or alkylbenzene oil (small amount) as the refrigerant oil applied to flares and flange connections.

If large amount of mineral oil enter, that can cause deterioration of refrigerant oil etc.

Charge refrigerant from liquid phase of gas cylinder.

If the refrigerant is charged from gas phase, composition change may occur in refrigerant and the efficiency will be lowered.

Do not use refrigerant other than R410A.

If other refrigerant (R22 etc.) is used, chlorine in refrigerant can cause deterioration of refrigerant oil etc.

Use a vacuum pump with a reverse flow check valve.

Vacuum pump oil may flow back into refrigerant cycle and that can cause deterioration of refrigerant oil etc.

Use the following tools specifically designed for use with R410A refrigerant.

The following tools are necessary to use R410A refrigerant.

Tools for R410A	
Gauge manifold	Flare tool
Charge hose	Size adjustment gauge
Gas leak detector	Vacuum pump adaptor
Torque wrench	Electronic refrigerant charging scale

Keep the tools with care.

If dirt, dust or moisture enter into refrigerant cycle, that can cause deterioration of refrigerant oil or malfunction of compressor.

Do not use a charging cylinder.

If a charging cylinder is used, the composition of refrigerant will change and the efficiency will be lowered.

Ventilate the room if refrigerant leaks during operation. If refrigerant comes into contact with a flame, poisonous gases will be released.

[1] Cautions for service

- (1) Perform service after collecting the refrigerant left in unit completely.
- (2) Do not release refrigerant in the air.
- (3) After completing service, charge the cycle with specified amount of refrigerant.
- (4) When performing service, install a filter drier simultaneously.
Be sure to use a filter drier for new refrigerant.

[2] Additional refrigerant charge

When charging directly from cylinder

- Check that cylinder for R410A on the market is syphon type.
- Charging should be performed with the cylinder of syphon stood vertically. (Refrigerant is charged from liquid phase.)

● Display

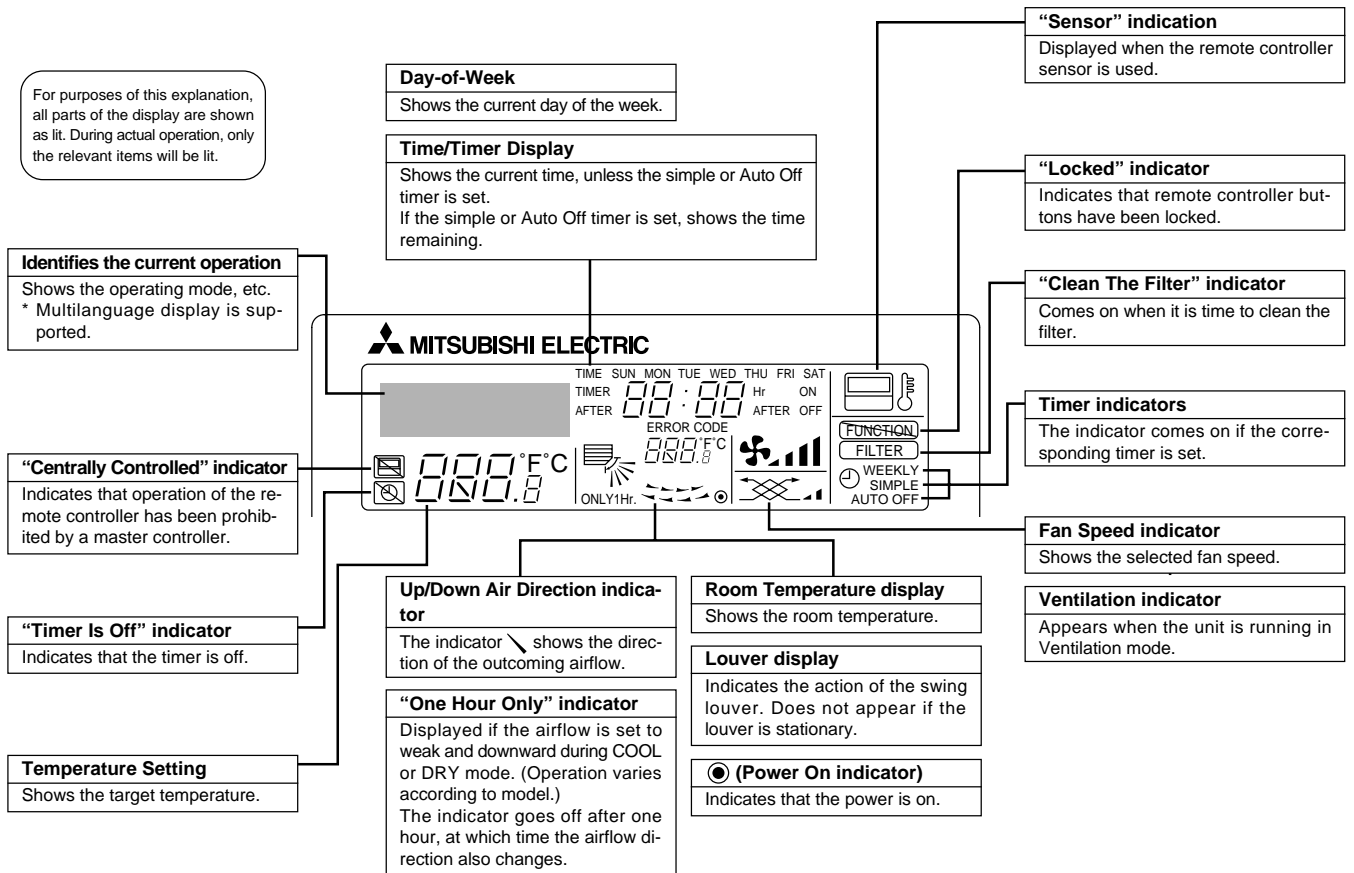

Caution

- Only the Power on indicator lights when the unit is stopped and power supplied to the unit.
- If you press a button for a feature that is not installed at the indoor unit, the remote controller will display the "Not Available" message.
If you are using the remote controller to drive multiple indoor units, this message will appear only if the feature is not present at the parent unit.
- When power is turned ON for the first time, it is normal that "PLEASE WAIT" is displayed on the room temperature indication (For max. 2minutes). Please wait until this "PLEASE WAIT" indication disappear then start the operation.

● Wireless remote controller

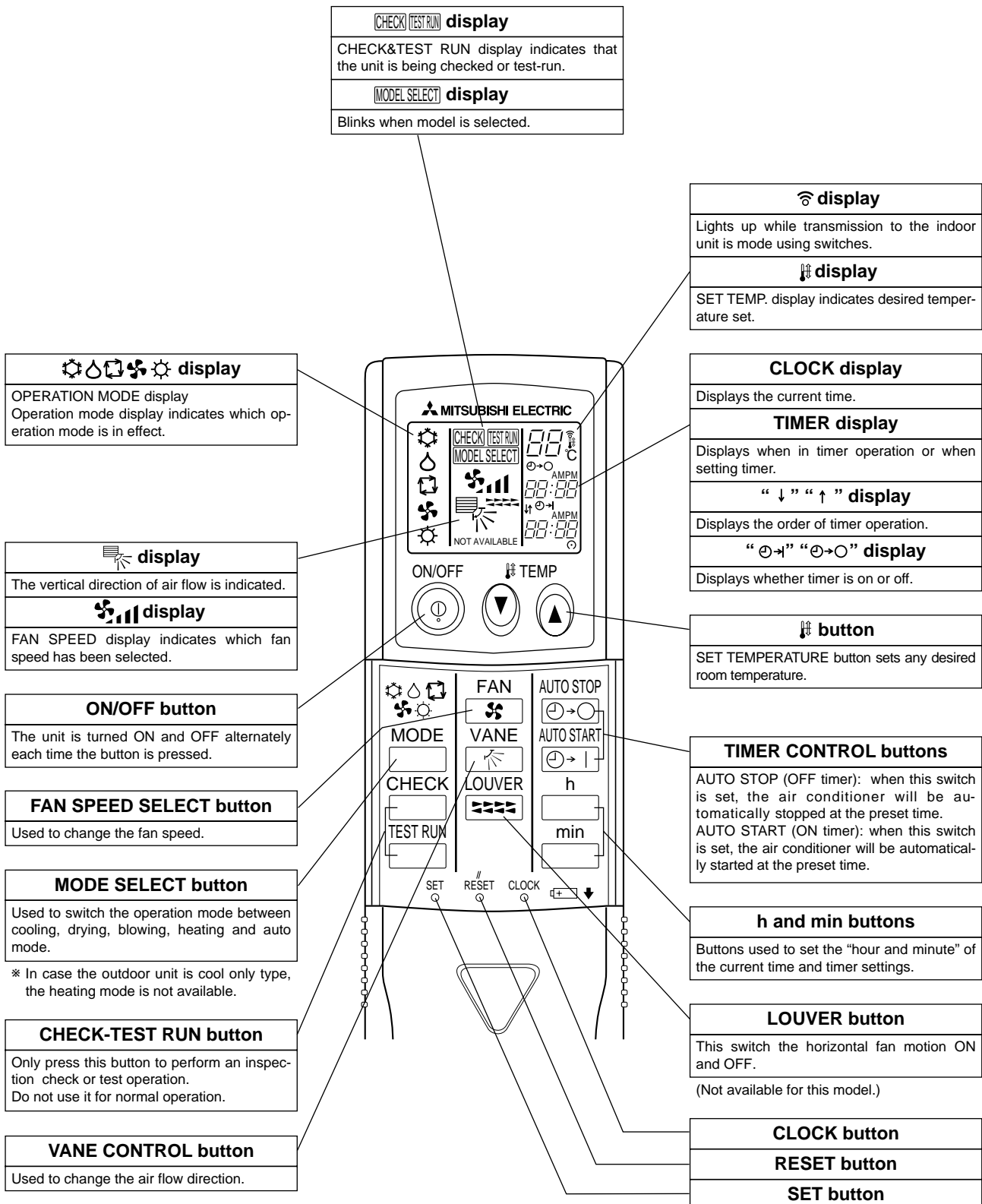

4

SPECIFICATIONS

Service Ref.			PLA-RP100AA2.UK		
INDOOR UNIT	Mode		Cooling	Heating	
	Power supply(phase, cycle, voltage)		Single phase, 50Hz, 230V		
	Input	kW	0.18	0.18	
	Running current	A	0.92	0.92	
	External finish (Panel)		Munsell 0.70Y 8.59/0.97		
	Heat exchanger		Plate fin coil		
	Fan	Fan(drive) × No.		Turbo fan (direct) × 1	
		Fan motor output	kW	0.120	
		Airflow(Low-Medium2-Medium1-High)	m ³ /min(CFM)	19-21-23-27(670-740-810-950)	
		External static pressure	Pa(mmAq)	0(direct blow)	
	Booster heater		-		
	Operation control & Thermostat		Remote controller & built-in		
	Noise level(Low-Medium2-Medium1-High)		33-36-39-41		
	Unit drain pipe I.D.		32(1-1/4)		
	Dimensions	W	mm(in.)	UNIT : 840 (33-1/16) PANEL : 950 (37-3/8)	
D		mm(in.)	UNIT : 840 (33-1/16) PANEL : 950 (37-3/8)		
H		mm(in.)	UNIT : 298 (11-3/4) PANEL : 30 (1-3/16)		
Weight		kg(lbs)	UNIT : 32 (71) PANEL : 5 (11)		

Service Ref.			PLA-RP125AA2.UK		
INDOOR UNIT	Mode		Cooling	Heating	
	Power supply(phase, cycle, voltage)		Single phase, 50Hz, 230V		
	Input	kW	0.18	0.18	
	Running current	A	0.92	0.92	
	External finish (Panel)		Munsell 0.70Y 8.59/0.97		
	Heat exchanger		Plate fin coil		
	Fan	Fan(drive) × No.		Turbo fan (direct) × 1	
		Fan motor output	kW	0.120	
		Airflow(Low-Medium2-Medium1-High)	m ³ /min(CFM)	24-25-27-30(850-880-950-1,060)	
		External static pressure	Pa(mmAq)	0(direct blow)	
	Booster heater		-		
	Operation control & Thermostat		Remote controller & built-in		
	Noise level(Low-Medium2-Medium1-High)		37-40-43-45		
	Unit drain pipe I.D.		32(1-1/4)		
	Dimensions	W	mm(in.)	UNIT : 840 (33-1/16) PANEL : 950 (37-3/8)	
D		mm(in.)	UNIT : 840 (33-1/16) PANEL : 950 (37-3/8)		
H		mm(in.)	UNIT : 298 (11-3/4) PANEL : 30 (1-3/16)		
Weight		kg(lbs)	UNIT : 32 (71) PANEL : 5 (11)		

Service Ref.			PLA-RP140AA2.UK		
INDOOR UNIT	Mode		Cooling	Heating	
	Power supply(phase, cycle, voltage)		Single phase, 50Hz, 230V		
	Input	kW	0.18	0.18	
	Running current	A	0.92	0.92	
	External finish (Panel)		Munsell 0.70Y 8.59/0.97		
	Heat exchanger		Plate fin coil		
	Fan	Fan(drive) x No.		Turbo fan (direct) × 1	
		Fan motor output	kW	0.120	
		Airflow(Low-Medium2-Medium1-High)	m ³ /min(CFM)	24-25-27-30(850-880-950-1,060)	
		External static pressure	Pa(mmAq)	0(direct blow)	
	Booster heater		-		
	Operation control & Thermostat		Remote controller & built-in		
	Noise level(Low-Medium2-Medium1-High)		37-40-43-45		
	Unit drain pipe I.D.		32(1-1/4)		
	Dimensions	W	mm(in.)	UNIT : 840 (33-1/16) PANEL : 950 (37-3/8)	
D		mm(in.)	UNIT : 840 (33-1/16) PANEL : 950 (37-3/8)		
H		mm(in.)	UNIT : 298 (11-3/4) PANEL : 30 (1-3/16)		
Weight		kg(lbs)	UNIT : 32 (71) PANEL : 5 (11)		

5

NOISE CRITERION CURVES

PLA-RP100AA2.UK

NOTCH	SPL(dB)	LINE
High	41	○—○
Medium1	39	△—△
Medium2	36	●—●
Low	33	▲—▲

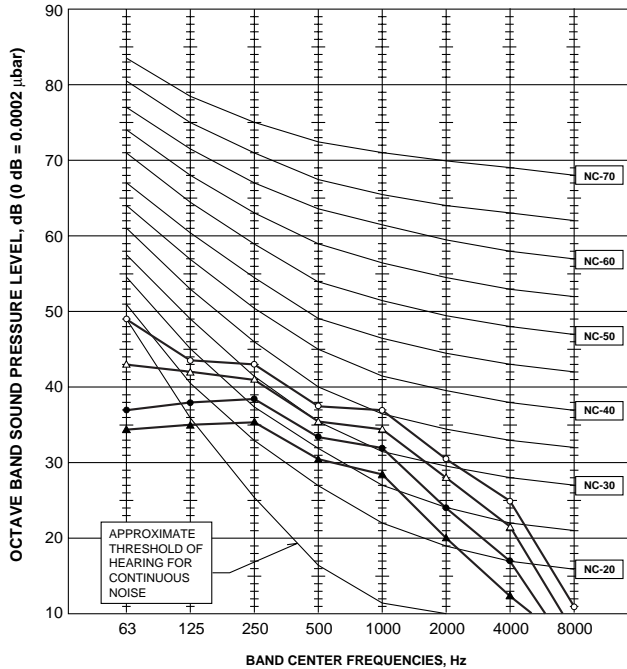

PLA-RP125AA2.UK

NOTCH	SPL(dB)	LINE
High	45	○—○
Medium1	43	△—△
Medium2	40	●—●
Low	37	▲—▲

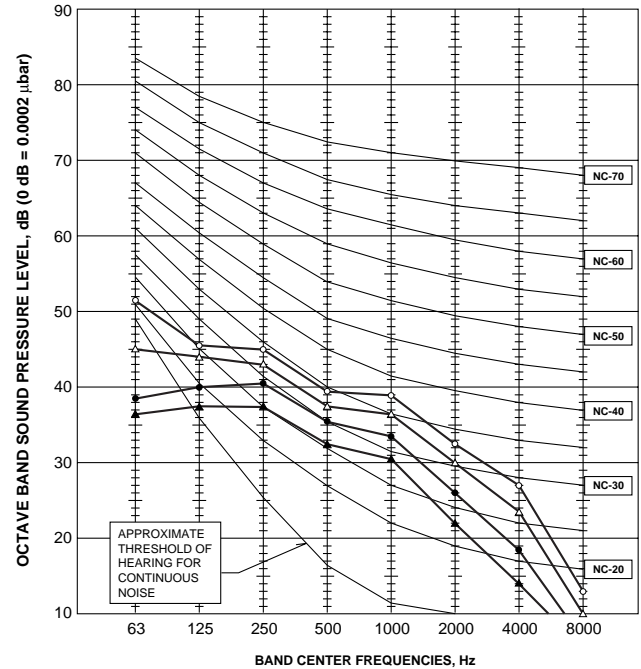

PLA-RP140AA2.UK

NOTCH	SPL(dB)	LINE
High	45	○—○
Medium1	43	△—△
Medium2	40	●—●
Low	37	▲—▲

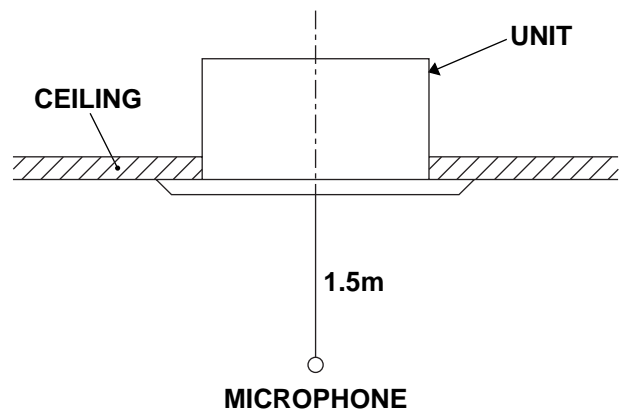
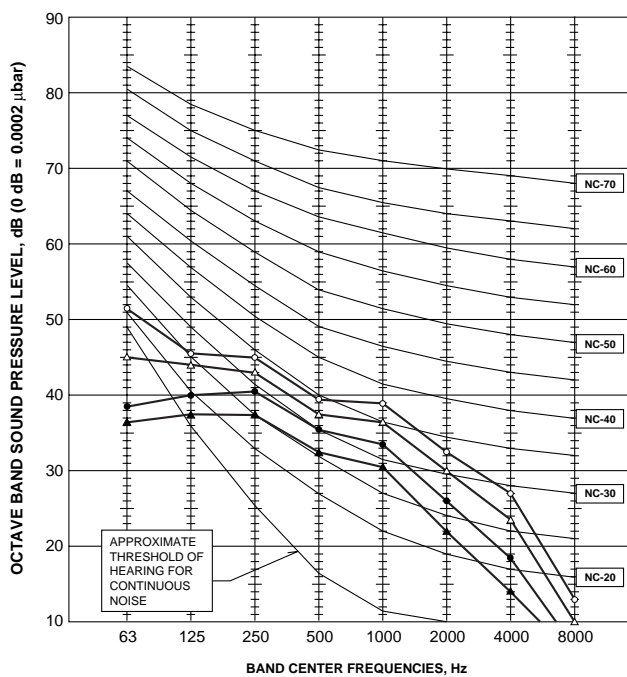

6

OUTLINES AND DIMENSIONS

INDOOR UNIT

PLA-RP100AA2.UK PLA-RP125AA2.UK PLA-RP140AA2.UK

Unit : mm

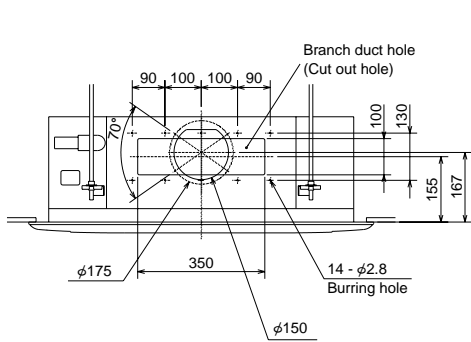

Detail drawing of fresh air intake

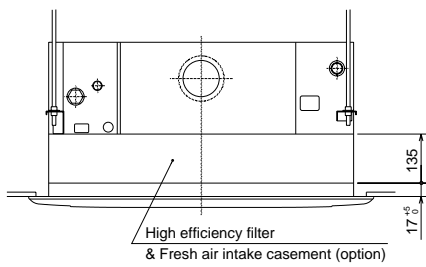
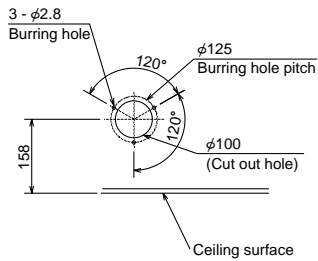

A (WIRELESS PANEL)

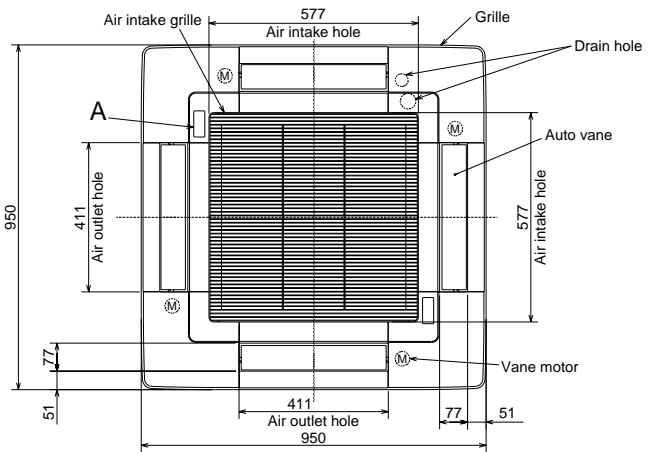
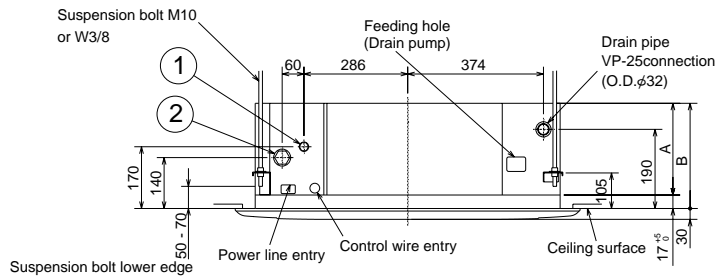
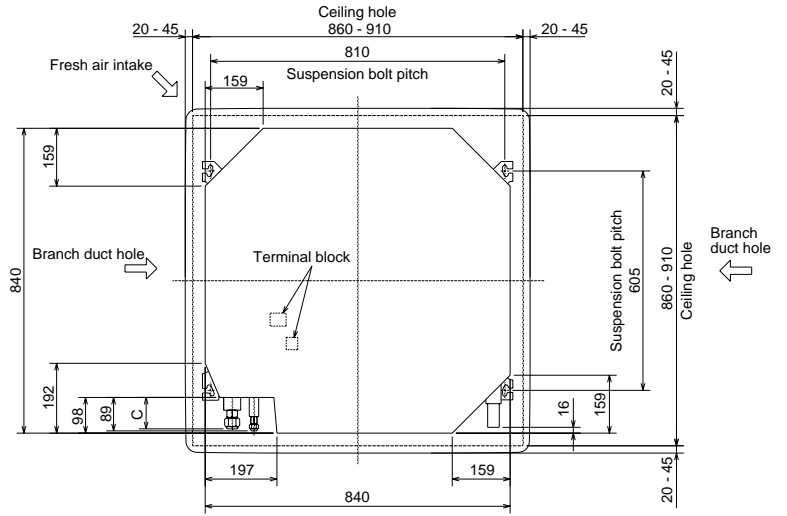
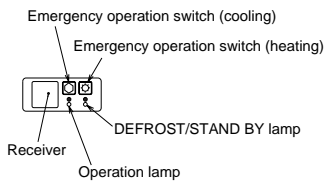

Use the current nuts meeting the pipe size of the outdoor unit.

Available pipe size

	RP100, 125, 140
① LIQUID SIDE	—
	$\phi 9.52$ ○
② GAS SIDE	—
	$\phi 15.88$ ○
	$\phi 19.05$

○ Factory flare nut attachment to the heat-exchanger.

Models	A	B	C
PLA-RP100,125,140AA2	281	298	84

7 WIRING DIAGRAM

PLA-RP100AA2.UK PLA-RP125AA2.UK PLA-RP140AA2.UK

[LEGEND]

SYMBOL	NAME	SYMBOL	NAME	SYMBOL	NAME
P.B	INDOOR POWER BOARD	MV	VANE MOTOR	W.B	WIRELESS REMOTE CONTROLLER BOARD
	FUSE(T5AL250V)	H2	DEW PREVENTION HEATER	RU	RECEIVING UNIT
	ZNR	DP	DRAIN-UP MACHINE	BZ	BUZZER
	IPM	DS	DRAIN SENSOR	LED1	LED(RUN INDICATOR)
I.B	INDOOR CONTROLLER BOARD	TB2	TERMINAL BLOCK (Indoor unit Power (option))	LED2	LED(HOT ADJUST)
	CN2L	TB4	TERMINAL BLOCK (INDOOR/OUTDOOR CONNECTING LINE)	SW1	SWITCH(HEATING ON/OFF)
	CN32	TB5, TB6	TERMINAL BLOCK(REMOTE CONTROLLER TRANSMISSION LINE)	SW2	SWITCH(COOLING ON/OFF)
	CN41				
	CN51				
	LED1	DCL	REACTOR		
	LED2	TH1	ROOM TEMP.THERMISTOR (0°C/15kΩ,25°C/5.4kΩ DETECT)		
	LED3	TH2	PIPE TEMP.THERMISTOR/LIQUID (0°C/15kΩ,25°C/5.4kΩ DETECT)		
	X1	TH5	COND./EVA. TEMP. THERMISTOR (0°C/15kΩ,25°C/5.4kΩ DETECT)		
	SW1				
	SW2				
	SWE				
MF	FAN MOTOR	R.B	WIRED REMOTE CONTROLLER BOARD		

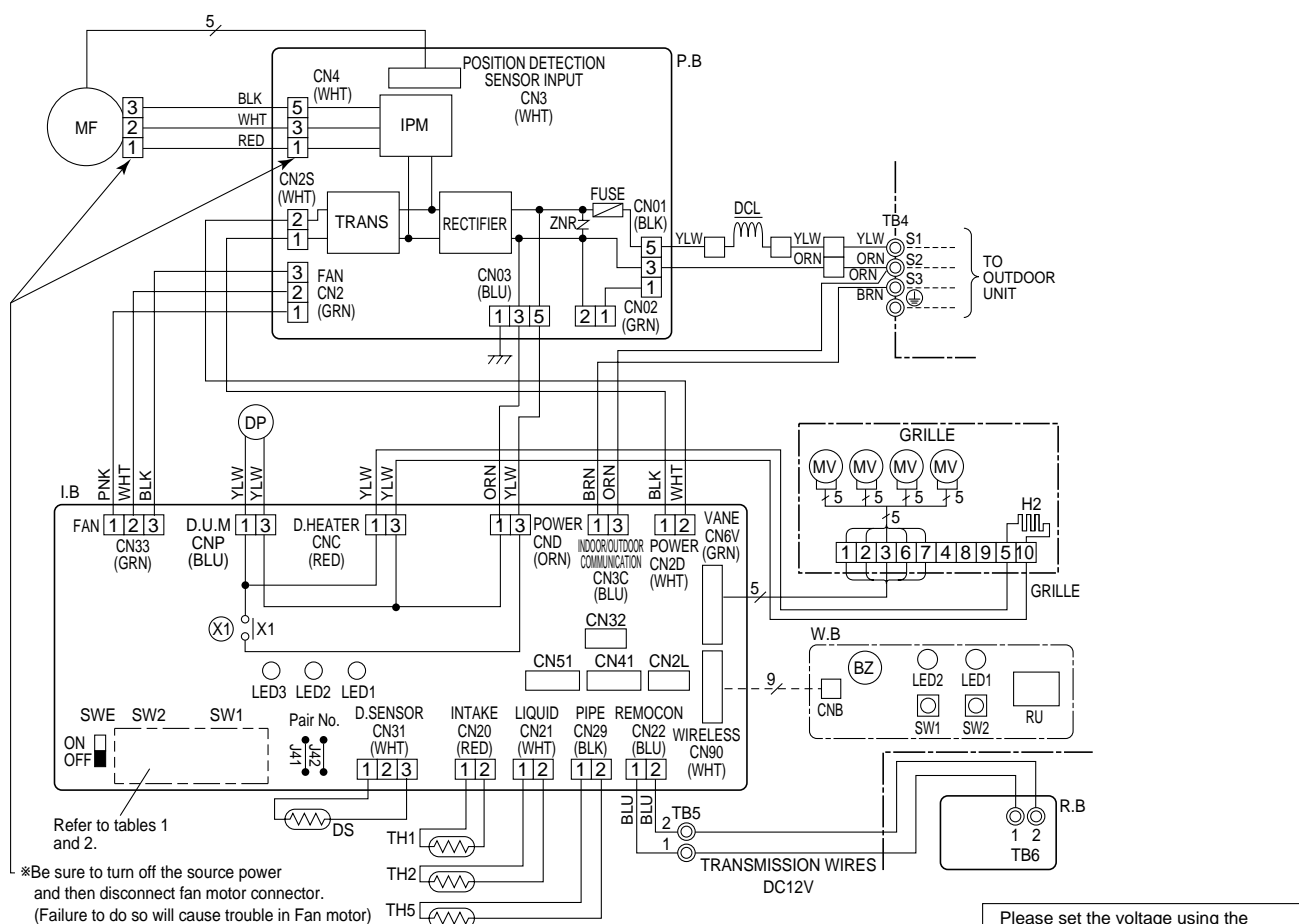

- NOTES: 1. Symbols used in wiring diagram above are, : Connector, : Terminal (block).
2. Indoor and outdoor connecting wires are made with polarities, make wiring matching terminal numbers (S1,S2,S3).
3. Since the outdoor side electric wiring may change be sure to check the outdoor unit electric wiring for servicing.
4. This diagram shows the wiring of indoor and outdoor connecting wires. (specification of 230V), adopting superimposed system of power and signal.
- *1 ; When work to supply power separately to indoor and outdoor unit was applied, refer to Fig1.
- *2 ; For power supply system of this unit, refer to the caution label located near this diagram.

(Table 1) SW1 (MODEL SELECTION)

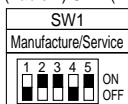

(Table 2) SW2 (CAPACITY CORD)

SW2			
MODELS	Manufacture/Service	MODELS	Manufacture/Service
PLA-RP100AA2	1 2 3 4 5 ON OFF	PLA-RP140AA2	1 2 3 4 5 ON OFF
PLA-RP125AA2	1 2 3 4 5 ON OFF		

Please set the voltage using the remote controller. For the setting method, please refer to the indoor unit Installation Manual.

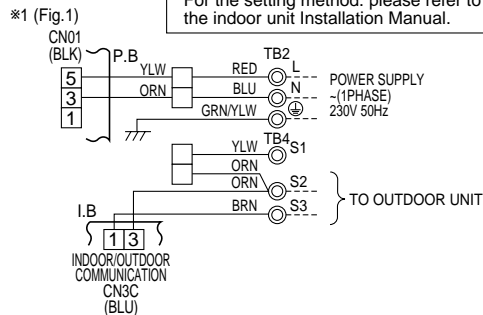

PLA-RP100AA2.UK PLA-RP125AA2.UK PLA-RP140AA2.UK

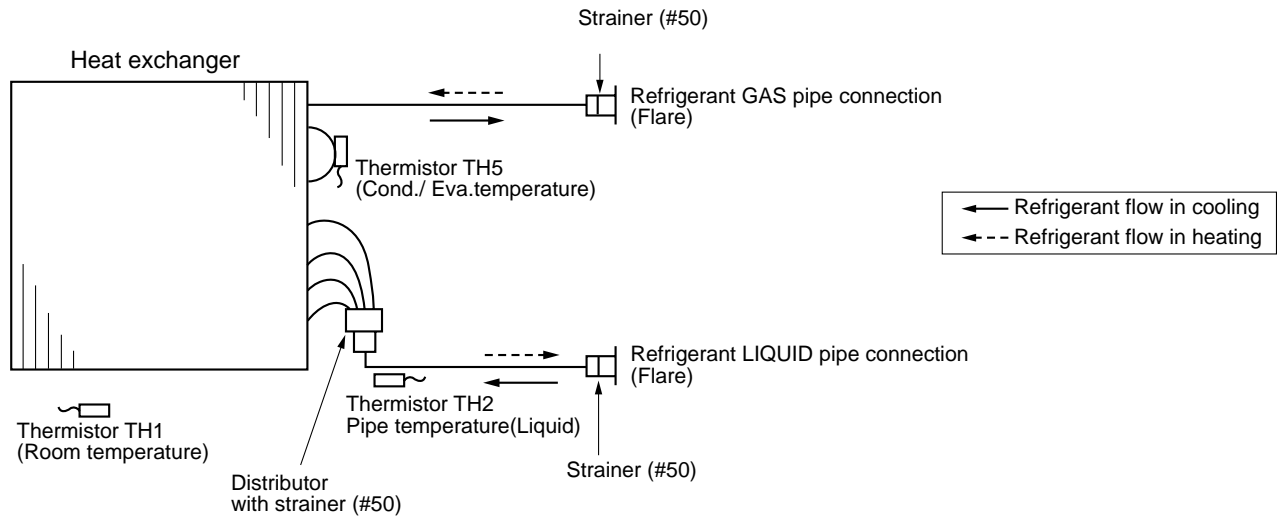

9-1. TROUBLESHOOTING

<Error code display by self-diagnosis and actions to be taken for service (summary)>

Present and past error codes are logged and displayed on the wired remote controller or controller board of outdoor unit. Actions to be taken for service and the inferior phenomenon reoccurrence at field are summarized in the table below. Check the contents below before investigating details.

Unit conditions at service	Error code	Actions to be taken for service (summary)
The inferior phenomenon is reoccurring.	Displayed	Judge what is wrong and take a corrective action according to "SELF-DIAGNOSIS ACTION TABLE" (9-3).
	Not displayed	Identify the cause of the inferior phenomenon and take a corrective action according to "TROUBLESHOOTING BY INFERIOR PHENOMENA" (9-4).
The inferior phenomenon is not reoccurring.	Logged	<ul style="list-style-type: none"> ①Consider the temporary defects such as the work of protection devices in the refrigerant circuit including compressor, poor connection of wiring, noise and etc. Re-check the symptom, and check the installation environment, refrigerant amount, weather when the inferior phenomenon occurred, and wiring related. ②Reset error code logs and restart the unit after finishing service. ③There is no abnormality in electrical components, controller boards, and remote controller.
	Not logged	<ul style="list-style-type: none"> ①Recheck the abnormal symptom. ②Identify the cause of the inferior phenomenon and take a corrective action according to "TROUBLESHOOTING BY INFERIOR PHENOMENA" (9-4). ③Continue to operate unit for the time being if the cause is not ascertained. ④There is no abnormality in electrical components, controller boards, remote controller etc.

9-2. MALFUNCTION-DIAGNOSIS METHOD BY REMOTE CONTROLLER



<In case of trouble during operation>

When a malfunction occurs to air conditioner, both indoor unit and outdoor unit will stop and operation lamp blinks to inform unusual stop.

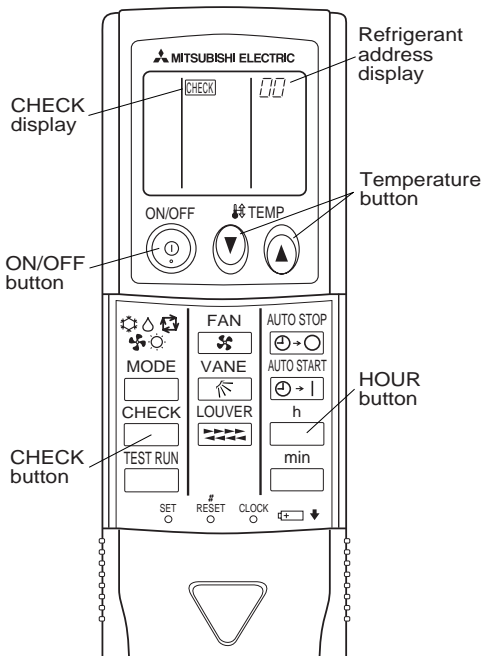
<Malfunction-diagnosis method at maintenance service>



[Procedure]

1. Press the CHECK button twice.
 - "CHECK" lights, and refrigerant address "00" flashes.
 - Check that the remote controller's display has stopped before continuing.
2. Press the temperature   buttons.
 - Select the refrigerant address of the indoor unit for the self-diagnosis.
 - Note: Set refrigerant address using the outdoor unit's DIP switch (SW1). (For more information, see the outdoor unit installation manual.)
3. Point the remote controller at the sensor on the indoor unit and press the HOUR button.
 - If an air conditioner error occurs, the indoor unit's sensor emits an intermittent buzzer sound, the operation light flashes, and the error code is output. (It takes 3 seconds at most for error code to appear.)
4. Point the remote controller at the sensor on the indoor unit and press the ON/OFF button.
 - The check mode is cancelled.

To be continued to the next page.

- Refer to the following tables for details on the check codes.

[Output pattern A]

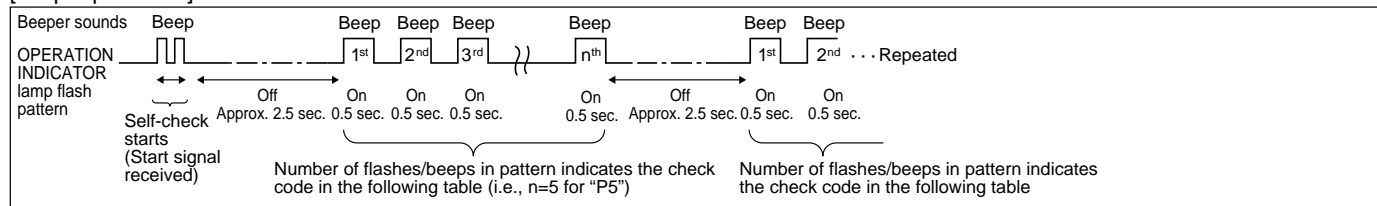

[Output pattern B]

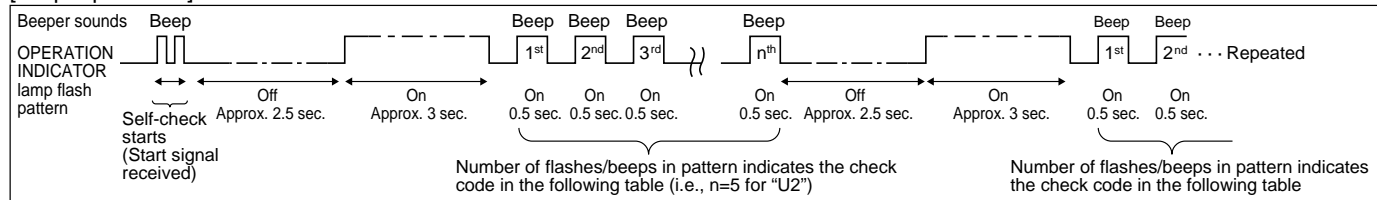

[Output pattern A] Errors detected by indoor unit

Wireless remote controller Beeper sounds/OPERATION INDICATOR lamp flashes (Number of times)	Wired remote controller ① Check code	Symptom	Remark
1	P1	Intake sensor error	
2	P2	Pipe (TH2) sensor error	
	P9	Pipe (TH5) sensor error	
3	E6, E7	Indoor/outdoor unit communication error	
4	P4	Drain sensor error	
5	P5	Drain pump error	
	PA	Forced compressor stop	
6	P6	Freeing/Overheating safeguard operation	
7	EE	Communication error between indoor and outdoor units	
8	P8	Pipe temperature error	
9	E4, E5	Remote controller signal receiving error	
10	-	-	
11	-	-	
12	Fb	Indoor unit control system error (memory error, etc.)	
-	E0, E3	Remote controller transmission error	
-	E1, E2	Remote controller control board error	

[Output pattern B] Errors detected by unit other than indoor unit (outdoor unit, etc.)

Wireless remote controller Beeper sounds/OPERATION INDICATOR lamp flashes (Number of times)	Wired remote controller ① Check code	Symptom	Remark
1	E9	Indoor/outdoor unit communication error (Transmitting error) (Outdoor unit)	For details, check the LED display of the outdoor controller board. As for outdoor unit, refer to outdoor unit's service manual.
2	UP	Compressor overcurrent interruption	
3	U3,U4	Open/short of outdoor unit thermistors	
4	UF	Compressor overcurrent interruption (When compressor locked)	
5	U2	Abnormal high discharging temperature/49C worked/ insufficient refrigerant	
6	U1,Ud	Abnormal high pressure (63H worked)/Overheating safeguard operation	
7	U5	Abnormal temperature of heat sink	
8	U8	Outdoor unit fan safeguard stop	
9	U6	Compressor overcurrent interruption/Abnormal of power module	
10	U7	Abnormality of super heat due to low discharge temperature	
11	U9,UH	Abnormality such as overvoltage or voltage shortage and abnormal synchronous signal to main circuit/Current sensor error	
12	-	-	
13	-	-	
14	Others	Other errors (Refer to the technical manual for the outdoor unit.)	

*1 If the beeper does not sound again after the initial two beeps to confirm the self-check start signal was received and the OPERATION INDICATOR lamp does not come on, there are no error records.

*2 If the beeper sounds three times continuously "beep, beep, beep (0.4 + 0.4 + 0.4 sec.)" after the initial two beeps to confirm the self-check start signal was received, the specified refrigerant address is incorrect.

- On wireless remote controller
- ② The continuous buzzer sounds from receiving section of indoor unit.
- ③ Blink of operation lamp
- On wired remote controller
- ① Check code displayed in the LCD.

• If the unit cannot be operated properly after the above test run has been performed, refer to the following table to remove the cause.

Symptom		Cause
Wired remote controller	LED 1, 2 (PCB in outdoor unit)	
PLEASE WAIT	For about 2 minutes following power-on	After LED 1, 2 are lighted, LED 2 is turned off, then only LED 1 is lighted. (Correct operation)
PLEASE WAIT → Error code	After about 2 minutes has expired following power-on	Only LED 1 is lighted. → LED 1, 2 blink.
Display messages do not appear even when operation switch is turned ON (operation lamp does not light up).		Only LED 1 is lighted. → LED 1 blinks twice, LED 2 blinks once.

On the wireless remote controller with condition above, following phenomena takes place.

- No signals from the remote controller are accepted.
- OPE lamp is blinking.
- The buzzer makes a short piping sound.

Note:

Operation is not possible for about 30 seconds after cancellation of function selection. (Correct operation)

For description of each LED (LED1, 2, 3) provided on the indoor controller, refer to the following table.

LED1 (power for microcomputer)	Indicates whether control power is supplied. Make sure that this LED is always lit.
LED2 (power for remote controller)	Indicates whether power is supplied to the remote controller. This LED lights only in the case of the indoor unit which is connected to the outdoor unit refrigerant address "0".
LED3 (communication between indoor and outdoor units)	Indicates state of communication between the indoor and outdoor units. Make sure that this LED is always blinking.

Note: Refer to the manual of outdoor unit for the details of display such as F, U, and other E.

9-3. SELF-DIAGNOSIS ACTION TABLE

Error Code	Meaning of error code and detection method	Cause	Countermeasure
P1	<p>Abnormality of room temperature thermistor (TH1)</p> <p>① The unit is in three-minute resume prevention mode if short/open of thermistor is detected. Abnormal if the unit does not reset normally after three minutes. (The unit returns to normal operation, if it has normally reset.)</p> <p>② Constantly detected during cooling, drying, and heating operation. Short: 90°C or more Open: -40°C or less</p>	<p>① Defective thermistor characteristics.</p> <p>② Contact failure of connector (CN20) on the indoor controller board. (Insert failure)</p> <p>③ Breaking of wire or contact failure of thermistor wiring.</p> <p>④ Defective indoor controller board.</p>	<p>①-③ Check resistance value of thermistor. 0°C15.0kΩ 10°C9.6kΩ 20°C6.3kΩ 30°C4.3kΩ 40°C3.0kΩ If you put force on (draw or bend) the lead wire with measuring resistance value of thermistor breaking of wire or contact failure can be detected.</p> <p>② Check contact failure of connector (CN20) on the indoor controller board. Refer to 9-7. Turn the power on again and check restart after inserting connector again.</p> <p>④ Check room temperature display on remote controller. Replace indoor controller board if there is abnormal difference with actual room temperature.</p> <p>Turn the power off, and on again to operate after check.</p>
P2	<p>Abnormality of pipe temperature thermistor/Liquid (TH2)</p> <p>① The unit is in three-minute resume prevention mode if short/open of thermistor is detected. Abnormal if the unit does not reset normally after three minutes. (The unit returns to normal operation, if it has normally reset.)</p> <p>② Constantly detected during cooling, drying, and heating (except defrosting) operation. Short: 90°C or more Open: -40°C or less</p>	<p>① Defective thermistor characteristics.</p> <p>② Contact failure of connector (CN21) on the indoor controller board. (Insert failure)</p> <p>③ Breaking of wire or contact failure of thermistor wiring.</p> <p>④ Defective refrigerant circuit is causing thermistor temperature of 90°C or more or -40°C or less.</p> <p>⑤ Defective indoor controller board.</p>	<p>①-③ Check resistance value of thermistor. For characteristics, refer to (P1) above.</p> <p>② Check contact failure of connector (CN21) on the indoor controller board. Refer to 9-7. Turn the power on and check restart after inserting connector again.</p> <p>④ Check pipe <liquid> temperature with remote controller in test run mode. If pipe <liquid> temperature is exclusively low (in cooling mode) or high (in heating mode), refrigerant circuit may have defective.</p> <p>⑤ Check pipe <liquid> temperature with remote controller in test run mode. If there is exclusive difference with actual pipe <liquid> temperature, replace indoor controller board.</p> <p>Turn the power off, and on again to operate after check.</p>
P4	<p>Abnormality of drain sensor (DS)</p> <p>① Suspensive abnormality, if short/open of thermistor is detected for 30 seconds continuously. Turn off compressor and indoor fan.</p> <p>② Short/open is detected for 30 seconds continuously during suspensive abnormality. (The unit returns to normal operation, if it has normally reset.)</p> <p>③ Detect the following condition.</p> <ul style="list-style-type: none"> • During cooling and drying operation. • In case that pipe <liquid> temperature - room temperature <-10deg (Except defrosting) • When pipe <liquid> temperature or room temperature is short/open temperature. • During drain pump operation. 	<p>① Defective thermistor characteristics</p> <p>② Contact failure of connector (CN31) on the indoor controller board. (Insert failure).</p> <p>③ Breaking of wire or contact failure of drain sensor wiring.</p> <p>④ Defective indoor controller board.</p>	<p>①-③ Check resistance value of thermistor. 0°C6.0kΩ 10°C3.9kΩ 20°C2.6kΩ 30°C1.8kΩ 40°C1.3kΩ</p> <p>② Check contact failure of connector (CN31) on the indoor controller board. Refer to 9-7. Turn the power on again and check restart after inserting connector again.</p> <p>④ Replace indoor controller board if drain pump operates with the line of drain sensor connector CN31-① and ② is short-circuited, and abnormality reappears.</p> <p>Turn the power off, and on again to operate after check.</p>
P5	<p>Malfunction of drain pump (DP)</p> <p>① Suspensive abnormality, if thermistor of drain sensor is let heat itself and temperature rises slightly. Turn off compressor and indoor fan.</p> <p>② Drain pump is abnormal if the condition above is detected during suspensive abnormality.</p> <p>③ Constantly detected during drain pump operation.</p>	<p>① Malfunction of drain pump</p> <p>② Defective drain Clogged drain pump Clogged drain pipe</p> <p>③ Attached drop of water at the drain sensor</p> <ul style="list-style-type: none"> • Drops of drain trickles from lead wire. • Clogged filter is causing wave of drain. <p>④ Defective indoor controller board.</p>	<p>① Check if drain-up machine works.</p> <p>② Check drain function.</p> <p>③ Check the setting of lead wire of drain sensor and check clogs of the filter.</p> <p>④ Replace indoor controller board if drain pump operates with the line of drain sensor connector CN31-① and ② is short-circuited and abnormality reappears. Refer to 9-7.</p> <p>Turn the power off, and on again to operate after check.</p>



Error Code	Meaning of error code and detection method	Cause	Countermeasure
P6	<p>Freezing/overheating protection is working</p> <p>① Freezing protection (Cooling mode) The unit is in six-minute resume prevention mode if pipe <liquid or condenser/evaporator> temperature stays under -15°C for three minutes, three minutes after the compressor started. Abnormal if it stays under -15°C for three minutes again within 16 minutes after six-minute resume prevention mode. <Frost prevention mode> If pipe <liquid or condenser-evaporator> temperature is 2°C or below when 16 minutes has passed after compressor starts operating, unit will start operating in frost prevention mode which stops compressor operation. After that, when pipe <liquid or condenser/evaporator> temperature stays 10°C or more for 3 minutes, frost prevention mode will be released and compressor will restart its operation.</p> <p>② Overheating protection (Heating mode) The units is in six-minute resume prevention mode if pipe <condenser / evaporator> temperature is detected as over 70°C after the compressor started. Abnormal if the temperature of over 70°C is detected again within 10 minutes after six-minute resume prevention mode.</p>	<p>(Cooling or drying mode)</p> <p>① Clogged filter (reduced airflow) ② Short cycle of air path ③ Low-load (low temperature) operation beyond the tolerance range ④ Defective indoor fan motor • Fan motor is defective. • Indoor controller board is defective. • Indoor power board (fan-control circuit) is defective.</p> <p>⑤ Defective outdoor fan control ⑥ Overcharge of refrigerant ⑦ Defective refrigerant circuit (clogs)</p> <p>(Heating mode)</p> <p>① Clogged filter (reduced airflow) ② Short cycle of air path ③ Over-load (high temperature) operation beyond the tolerance range ④ Defective indoor fan motor • Fan motor is defective. • Indoor controller board is defective. • Indoor power board (fan-control circuit) is defective.</p> <p>⑤ Defective outdoor fan control ⑥ Overcharge of refrigerant ⑦ Defective refrigerant circuit (clogs) ⑧ Bypass circuit of outdoor unit is defective.</p>	<p>(Cooling or drying mode)</p> <p>① Check clogs of the filter. ② Remove shields.</p> <p>④ Refer to 9-4.(5).</p> <p>⑤ Check outdoor fan motor. ⑥⑦ Check operating condition of refrigerant circuit.</p> <p>(Heating mode)</p> <p>① Check clogs of the filter. ② Remove shields.</p> <p>④ Refer to 9-4.(5).</p> <p>⑤ Check outdoor fan motor. ⑥-⑧ Check operating condition of refrigerant circuit.</p>
P8	<p>Abnormality of pipe temperature</p> <p><Cooling mode> Detected as abnormal when the pipe temperature is not in the cooling range 3 minutes later of compressor start and 6 minutes later of the liquid or condenser/evaporator pipe is out of cooling range. Note 1) It takes at least 9 min. to detect. Note 2) Abnormality P8 is not detected in drying mode. Cooling range : -3 deg ≥ (TH-TH1) TH: Lower temperature between: liquid pipe temperature (TH2) and condenser/evaporator temperature (TH5) TH1: Intake temperature</p> <p><Heating mode> When 10 seconds have passed after the compressor starts operation and the hot adjustment mode has finished, the unit is detected as abnormal when condenser/evaporator pipe temperature is not in heating range within 20 minutes.</p> <p>Note 3) It takes at least 27 minutes to detect abnormality. Note 4) It excludes the period of defrosting (Detection restarts when defrosting mode is over) Heating range : 3 deg ≤ (TH5-TH1)</p>	<p>① Slight temperature difference between indoor room temperature and pipe <liquid or condenser / evaporator> temperature thermistor • Shortage of refrigerant • Disconnected holder of pipe <liquid or condenser / evaporator> thermistor • Defective refrigerant circuit</p> <p>② Converse connection of extension pipe (on plural units connection)</p> <p>③ Converse wiring of indoor/outdoor unit connecting wire (on plural units connection)</p> <p>④ Defective detection of indoor room temperature and pipe <condenser / evaporator> temperature thermistor</p> <p>⑤ Stop valve is not opened completely.</p>	<p>①~④ Check pipe <liquid or condenser / evaporator> temperature with room temperature display on remote controller and outdoor controller circuit board. Pipe <liquid or condenser / evaporator> temperature display is indicated by setting SW2 of outdoor controller circuit board as follows.</p> <p>(Conduct temperature check with outdoor controller circuit board after connecting 'A-Control Service Tool(PAC-SK52ST)')</p> <p>②③ Check converse connection of extension pipe or converse wiring of indoor/outdoor unit connecting wire.</p>

Error Code	Meaning of error code and detection method	Cause	Countermeasure
P9	<p>Abnormality of pipe temperature thermistor / Condenser-Evaporator (TH5)</p> <p>① The unit is in three-minute resume protection mode if short/open of thermistor is detected. Abnormal if the unit does not get back to normal within three minutes. (The unit returns to normal operation, if it has normally reset.)</p> <p>② Constantly detected during cooling, drying, and heating operation (except defrosting) Short: 90°C or more Open: -40°C or less</p>	<p>① Defective thermistor characteristics</p> <p>② Contact failure of connector (CN29) on the indoor controller board. (Insert failure)</p> <p>③ Breaking of wire or contact failure of thermistor wiring.</p> <p>④ Temperature of thermistor is 90°C or more or -40°C or less caused by defective refrigerant circuit.</p> <p>⑤ Defective indoor controller board.</p>	<p>①-③ Check resistance value of thermistor. For characteristics, refer to (P1) above.</p> <p>② Check contact failure of connector (CN29) on the indoor controller board. Refer to 9-7. Turn the power on and check restart after inserting connector again.</p> <p>④ Operate in test run mode and check pipe <condenser / evaporator> temperature with outdoor controller circuit board. If pipe <condenser / evaporator> temperature is exclusively low (in cooling mode) or high (in heating mode), refrigerant circuit may have defective.</p> <p>⑤ Operate in test run mode and check pipe <condenser / evaporator> temperature with outdoor control circuit board. If there is exclusive difference with actual pipe <condenser / evaporator> temperature replace indoor controller board. There is no abnormality if none of above comes within the unit. Turn the power off and on again to operate.</p> <p>(In case of checking pipe temperature with outdoor controller circuit board, be sure to connect A-control service tool (PAC-SK52ST).)</p>
E0 or E4	<p>Remote controller transmission error(E0)/signal receiving error(E4)</p> <p>① Abnormal if main or sub remote controller can not receive normally any transmission from indoor unit of refrigerant address "0" for three minutes. (Error code : E0)</p> <p>② Abnormal if sub remote controller could not receive for any signal for two minutes. (Error code: E0)</p> <p>① Abnormal if indoor controller board can not receive normally any data from remote controller board or from other indoor controller board for three minutes. (Error code: E4)</p> <p>② Indoor controller board cannot receive any signal from remote controller for two minutes. (Error code: E4)</p>	<p>① Contact failure at transmission wire of remote controller</p> <p>② All remote controllers are set as "sub" remote controller. In this case, E0 is displayed on remote controller, and E4 is displayed at LED (LED1, LED2) on the outdoor controller circuit board.</p> <p>③ Mis-wiring of remote controller.</p> <p>④ Defective transmitting receiving circuit of remote controller</p> <p>⑤ Defective transmitting receiving circuit of indoor controller board of refrigerant address "0".</p> <p>⑥ Noise has entered into the transmission wire of remote controller.</p>	<p>① Check disconnection or looseness of indoor unit or transmission wire of remote controller.</p> <p>② Set one of the remote controllers "main". If there is no problem with the action above.</p> <p>③ Check wiring of remote controller.</p> <ul style="list-style-type: none"> • Total wiring length: max.500m (Do not use cable 3 or more) • The number of connecting indoor units: max.16units • The number of connecting remote controller: max.2units <p>When it is not the above-mentioned problem of ①-③</p> <p>④ Diagnose remote controllers.</p> <p>a) When "RC OK" is displayed, Remote controllers have no problem. Put the power off, and on again to check. If abnormality generates again, replace indoor controller board.</p> <p>b) When "RC NG" is displayed, Replace remote controller.</p> <p>c) When "RC E3" is displayed,</p> <p>d) When "ERC 00-06" is displayed, [c),d)→Noise may be causing abnormality.]</p> <p>* If the unit is not normal after replacing indoor controller board in group control, indoor controller board of address "0" may be abnormal.</p>
E3 or E5	<p>Remote controller transmission error(E3)/signal receiving error(E5)</p> <p>① Abnormal if remote controller could not find blank of transmission path for six seconds and could not transmit. (Error code: E3)</p> <p>② Remote controller receives transmitted data at the same time, compares the data, and when detecting it, judges different data to be abnormal 30 continuous times. (Error code: E3)</p> <p>① Abnormal if indoor controller board could not find blank of transmission path. (Error code: E5)</p> <p>② Indoor controller board receives transmitted data at the same time, compares the data, and when detecting it, judges different data to be abnormal 30 continuous times. (Error code: E5)</p>	<p>① Two remote controller are set as "main." (In case of 2 remote controllers)</p> <p>② Remote controller is connected with two indoor units or more.</p> <p>③ Repetition of refrigerant address.</p> <p>④ Defective transmitting receiving circuit of remote controller.</p> <p>⑤ Defective transmitting receiving circuit of indoor controller board.</p> <p>⑥ Noise has entered into transmission wire of remote controller.</p>	<p>① Set a remote controller to main, and the other to sub.</p> <p>② Remote controller is connected with only one indoor unit.</p> <p>③ The address changes to a separate setting.</p> <p>④-⑥ Diagnose remote controller.</p> <p>a) When "RC OK" is displayed, remote controllers have no problem. Put the power off, and on again to check. When becoming abnormal again, replace indoor controller board.</p> <p>b) When "RC NG" is displayed, replace remote controller.</p> <p>c) When "RC E3" or "ERC 00-66" is displayed, noise may be causing abnormality.</p>



Error Code	Meaning of error code and detection method	Cause	Countermeasure
E6	Indoor/outdoor unit communication error (Signal receiving error) ① Abnormal if indoor controller board cannot receive any signal normally for six minutes after putting the power on. ② Abnormal if indoor controller board cannot receive any signal normally for three minutes. ③ Consider the unit abnormal under the following condition: When two or more indoor units are connected to one outdoor unit, indoor controller board cannot receive a signal for three minutes from outdoor controller circuit board, a signal which allows outdoor controller circuit board to transmit signals.	① Contact failure, short circuit or, mis-wiring (converse wiring) of indoor/outdoor unit connecting wire ② Defective transmitting receiving circuit of indoor controller board ③ Defective transmitting receiving circuit of indoor controller board ④ Noise has entered into indoor/outdoor unit connecting wire.	* Check LED display on the outdoor control circuit board. (Connect A-control service tool, PAC-SK52ST.) Refer to EA-EC item if LED displays EA-EC. ① Check disconnection or looseness of indoor/outdoor unit connecting wire of indoor unit or outdoor unit. Check all the units in case of twin triple indoor unit system. ②-④ Turn the power off, and on again to check. If abnormality generates again, replace indoor controller board or outdoor controller circuit board. * Other indoor controller board may have defective in case of twin triple indoor unit system.
E7	Indoor/outdoor unit communication error (Transmitting error) Abnormal if "1" receiving is detected 30 times continuously though indoor controller board has transmitted "0".	① Defective transmitting receiving circuit of indoor controller board ② Noise has entered into power supply. ③ Noise has entered into outdoor control wire.	①-③ Turn the power off, and on again to check. If abnormality generates again, replace indoor controller board.
Fb	Abnormality of indoor controller board Abnormal if data cannot be normally read from the nonvolatile memory of the indoor controller board.	① Defective indoor controller board.	① Replace indoor controller board.
E1 or E2	Abnormality of remote controller control board ① Abnormal if data cannot be normally read from the nonvolatile memory of the remote controller control board. (Error code: E1) ② Abnormal if the clock function of remote controller cannot be normally operated. (Error code: E2)	① Defective remote controller.	① Replace remote controller.
PA (2502) (2500)	Forced compressor stop (due to water leakage abnormality) ① When the intake temperature subtracted with liquid pipe temperature is less than -10°C, drain sensor is detected whether it is soaked in the water or not at the interval of 90 seconds. (Drain pump will start operating when the drain sensor is detected to be soaked in the water.) ② The unit has a water leakage abnormality when the following conditions, a and b, are satisfied while the above-mentioned detection is performed. a) The drain sensor is detected to be soaked in the water 10 times in a row. b) The intake temperature subtracted with liquid pipe temperature is detected to be less than -10°C for a total of 30 minutes. (When the drain sensor is detected to be NOT soaked in the water, the detection record of a and b will be cleared.) ③ The drain sensor detection is performed in operations other than cooling. (When the unit stops operating, during heating or fan operation, when the unit stops because of some abnormality) *Once the water leakage abnormality is detected, abnormality state will not be released until the main power is reset.	1) Drain pump trouble 2) Drain defective · Drain pump clogging · Drain pipe clogging 3) Open circuit of drain sensor side heater 4) Contact failure of drain sensor connector 5) Dew condensation on drain sensor · Drain water descends along lead wire. · Drain water waving due to filter clogging. 6) Extension piping connection difference at twin, triple, quadruple system. 7) Mis-wiring of indoor/ outdoor connecting at twin, triple, quadruple system. 8) Room temperature thermistor / liquid pipe temperature thermistor detection is defective.	Check the drain pump. Performance Please confirm whether water can be drained. Confirm the resistance of the drain sensor side heater. Check the connector contact failure. ① Check the drain sensor leadwire mounted. ② Check the filter clogging Check the piping connection. Check the indoor/ outdoor connecting wires. Check the room temperature display of remote controller. Check the indoor liquid pipe temperature display of outdoor controller board.

9-4. TROUBLESHOOTING BY INFERIOR PHENOMENA

Note: Refer to the manual of outdoor unit for the detail of remote controller.

Phenomena	Cause	Countermeasure
<p>(1)LED2 on indoor controller board is off.</p>	<ul style="list-style-type: none"> • When LED1 on indoor controller board is also off. ① Power supply of rated voltage is not supplied to outdoor unit. ② Defective outdoor controller circuit board. ③ Power supply of 220~240V is not supplied to indoor unit. ④ Defective indoor power board. ⑤ Defective indoor controller board. <p>(For the separate indoor/outdoor unit power supply system)</p> <ul style="list-style-type: none"> ① Power supply of 220~240V AC is not supplied to indoor unit. ② The connectors of the optional replacement kit are not used. ③ Defective indoor power board. ④ Defective indoor controller board. 	<ul style="list-style-type: none"> ① Check the voltage of outdoor power supply terminal block (L, N) or (L₃, N). <ul style="list-style-type: none"> • When AC 220~240V is not detected. Check the power wiring to outdoor unit and the breaker. • When AC 220~240V is detected. —Check ② (below). ② Check the voltage between outdoor terminal block S1 and S2. <ul style="list-style-type: none"> • When AC 220~240V is not detected. Check the fuse on outdoor controller circuit board. Check the wiring connection. • When AC 220~240V is detected. —Check ③ (below). ③ Check the voltage between indoor terminal block S1 and S2. <ul style="list-style-type: none"> • When AC 220~240V is not detected. Check indoor/outdoor unit connecting wire for mis-wiring. • When AC 220~240V is detected. —Check ④ (below). ④ Check voltage output from CN2S on indoor power board (DC14V). Refer to 9-7-1. <ul style="list-style-type: none"> • When no voltage is output. Check the wiring connection. • When output voltage is between DC12.6V and DC16V. —Check ⑤ (below). ⑤ Check the wiring connection between indoor controller board and indoor power board. If no problems are found, indoor controller board is defective.
	<ul style="list-style-type: none"> • When LED1 on indoor controller board is lit. ① Mis-setting of refrigerant address for outdoor unit (There is no unit corresponding to refrigerant address "0".) 	<ul style="list-style-type: none"> ① Reconfirm the setting of refrigerant address for outdoor unit. Set the refrigerant address to "0". (For grouping control system under which 2 or more outdoor units are connected, set one of the units to "0".) Set refrigerant address using SW1 (3-6) on outdoor controller circuit board.

Note: Refer to the manual of outdoor unit for the detail of remote controller.

Phenomena	Cause	Countermeasure
(2)LED2 on indoor controller board is blinking.	<ul style="list-style-type: none"> • When LED1 on indoor controller board is also blinking. Connection failure of indoor/outdoor unit connecting wire 	Check indoor/outdoor unit connecting wire for connection failure.
	<ul style="list-style-type: none"> • When LED1 is lit. ① Mis-wiring of remote controller wires Under twin triple indoor unit system, 2 or more indoor units are wired together. ② Refrigerant address for outdoor unit is wrong or not set. Under grouping control system, there are some units whose refrigerant address is 0. ③ Short-cut of remote controller wires ④ Defective remote controller 	<ul style="list-style-type: none"> ① Check the connection of remote controller wires in case of twin triple indoor unit system. When 2 or more indoor units are wired in one refrigerant system, connect remote controller wires to one of those units. ② Check the setting of refrigerant address in case of grouping control system. If there are some units whose refrigerant addresses are 0 in one group, set one of the units to 0 using SW1 (3-6) on outdoor controller circuit board. ③④ Remove remote controller wires and check LED2 on indoor controller board. <ul style="list-style-type: none"> • When LED2 is blinking, check the short-cut of remote controller wires. • When LED2 is lit, connect remote controller wires again and: if LED2 is blinking, remote controller is defective; if LED2 is lit, connection failure of remote controller terminal block etc. has returned to normal.
(3)Upward/downward vane performance failure	<ul style="list-style-type: none"> ① The vane is not downward during defrosting and heat preparation and when the thermostat is OFF in HEAT mode. (Working of COOL protection function) ② Vane motor does not rotate. <ul style="list-style-type: none"> • Defective vane motor • Breaking of wire or connection failure of connector • Up/down vane setting is "No vanes". ③ Upward/downward vane does not work. <ul style="list-style-type: none"> • The vane is set to fixed position. 	<ul style="list-style-type: none"> ① Normal operation (The vane is set to horizontal regardless of remote control.) ② Check ② (left). <ul style="list-style-type: none"> • Check the vane motor. (Refer to "How to check the parts".) • Check for breaking of wire or connection failure of connector. • Check "Up/down vane setting". (Unit function selection by remote controller). ③ Normal operation (Each connector on vane motor side is disconnected.)
(4)Receiver for wireless remote controller	<ul style="list-style-type: none"> ① Weak batteries of wireless remote controller. ② Contact failure of connector (CNB) on wireless remote controller board. (Insert failure) ③ Contact failure of connector (CN90) on indoor controller board.(Insert failure) ④ Contact failure of connector between wireless remote controller board and indoor controller board. 	<ul style="list-style-type: none"> ① Replace batteries of wireless remote controller. ②~④ Check contact failure of each connector. If no problems are found of connector, replace indoor controller board. When the same trouble occurs even if indoor controller board is replaced, replace wireless remote controller board.
(5)Defective operation of fan (The fan doesn't turn.)	<ul style="list-style-type: none"> ① Defective fan motor. (Fan motor's winding is short or open.) ② Defective fan motor. (Fan motor position sensor signal is not output.) ③ Defective indoor power board. (fan-control circuit). ④ Defective indoor controller board. 	<ul style="list-style-type: none"> ① Check the resistance of fan motor's winding. Refer to 9-6. ② Turn around the fan motor more than one revolution slowly, and check the voltage of connector CN3. (CN3:Refer to 9-7-1.) Between pin① and ⑤ or ② and ⑤ or ③ and ⑤: •0V DC → 5V DC → 0V DC (The output voltage changes.) → Normal •0V DC or 5V DC (The output voltage doesn't change.) → NG Replace the fan motor. ③ When the motor is normal (Check ① and ②), replace the indoor power board. ④ When ③ is OK, replace the indoor controller board.

To be continued to the next page.



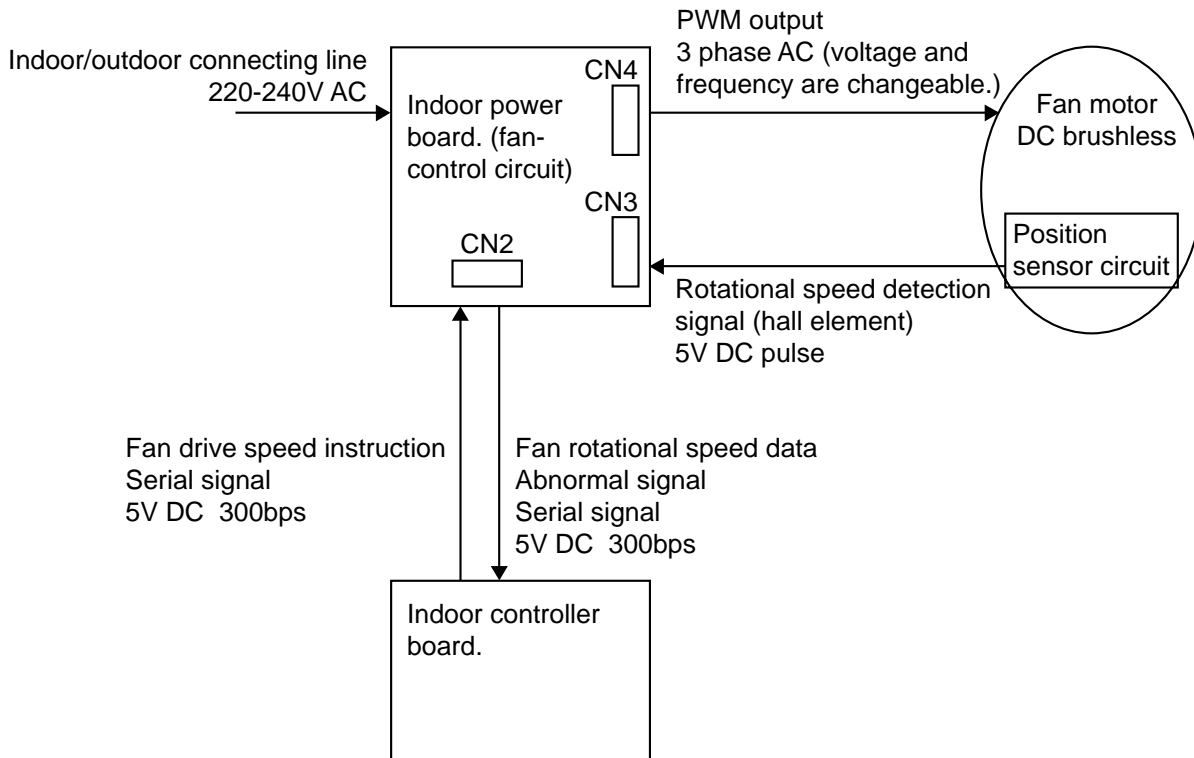

Role of each component when motor is driven.



9-5. EMERGENCY OPERATION

9-5-1. When wireless remote controller troubles or its battery is exhausted

1. Emergency operation is available in such a case using emergency operation switch equipped next to the receiver of indoor unit.
 2. To start operation
 - Cooling Operation.....Press  (Cooling) switch.
 - Heating Operation.....Press  (Heating) switch.
- ※When the unit starts operating, the operation lamp is lit.

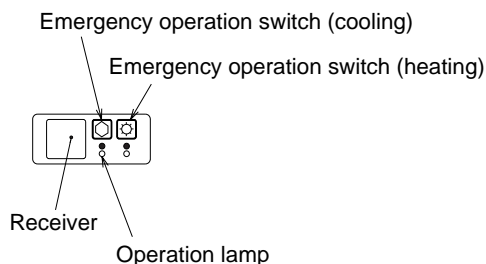

※Emergency operation will be performed as follows.

Mode	Cooling	Heating
Set temperature	24°C	24°C
Fan speed	High	High
Airflow direction	Horizontal (30deg)	Downward (70deg)

3. To stop operation
 - Press either emergency operation switch (cooling/heating).

9-5-2. When wired remote controller or indoor unit micro computer troubles

1. If there is not any other wrong when trouble occurs, emergency operation starts as the indoor controller board switch (SWE) is set to ON.

During the emergency operation the indoor unit is as follows;

(1) Indoor fan high speed operation (2) Drain pump operation
2. When emergency operating for COOL or HEAT, setting of the switch (SWE) in the indoor controller board and outdoor unit emergency operation are necessary.
3. Check items and notices as the emergency operation
 - (1) Emergency operation cannot be used as follows;
 - When the outdoor unit is something wrong.
 - When the indoor fan is something wrong.
 - When drain over flow protected operation is detected during self-diagnosis. (Error code : P5)
 - (2) Emergency operation will be serial operation by the power supply ON/OFF.
ON/OFF or temperature, etc. adjustment is not operated by the remote controller.
 - (3) Do not operate for a long time as cold air is blown when the outdoor unit starts defrosting operation during heat emergency operation.
 - (4) Cool emergency operation must be within 10 hours. Other wise, heat exchanger of indoor unit may get frosted.
 - (5) After completing the emergency operation, return the switch setting, etc. in former state.
 - (6) Since vane does not work at emergency operation, position the vane slowly by hand.

9-6. HOW TO CHECK THE PARTS

PLA-RP100AA2.UK PLA-RP125AA2.UK PLA-RP140AA2.UK

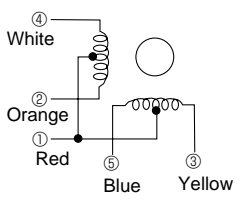
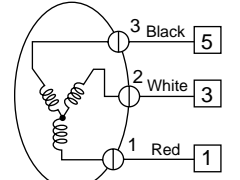
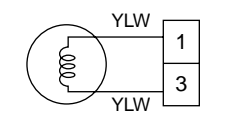
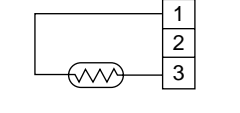
Parts name	Check points									
Room temperature thermistor (TH1) Pipe temperature thermistor/liquid (TH2) Condenser/Evaporator temperature thermistor (TH5)	Disconnect the connector then measure the resistance using a tester. (Surrounding temperature 10°C ~30°C) <table border="1" style="margin-left: 20px;"> <thead> <tr> <th>Normal</th> <th>Abnormal</th> </tr> </thead> <tbody> <tr> <td>4.3kΩ~9.6kΩ</td> <td>Open or short</td> </tr> </tbody> </table> (Refer to the thermistor)	Normal	Abnormal	4.3kΩ~9.6kΩ	Open or short					
Normal	Abnormal									
4.3kΩ~9.6kΩ	Open or short									
Vane motor(MV) 	Measure the resistance between the terminals using a tester. (Surrounding temperature 20°C ~30°C) <table border="1" style="margin-left: 20px;"> <thead> <tr> <th>Connector</th> <th>Normal</th> <th>Abnormal</th> </tr> </thead> <tbody> <tr> <td>Red - Yellow</td> <td rowspan="4">300Ω</td> <td rowspan="4">Open or short</td> </tr> <tr> <td>Red - Blue</td> </tr> <tr> <td>Red - Orange</td> </tr> <tr> <td>Red - White</td> </tr> </tbody> </table>	Connector	Normal	Abnormal	Red - Yellow	300Ω	Open or short	Red - Blue	Red - Orange	Red - White
Connector	Normal	Abnormal								
Red - Yellow	300Ω	Open or short								
Red - Blue										
Red - Orange										
Red - White										
Fan motor(MF) 	Measure the resistance between the terminals using a tester. (Winding temperature 20°C) <table border="1" style="margin-left: 20px;"> <thead> <tr> <th>Motor terminal</th> <th>Normal</th> <th>Abnormal</th> </tr> </thead> <tbody> <tr> <td>Black</td> <td rowspan="3">42.7Ω</td> <td rowspan="3">Open or short</td> </tr> <tr> <td>White</td> </tr> <tr> <td>Red</td> </tr> </tbody> </table>	Motor terminal	Normal	Abnormal	Black	42.7Ω	Open or short	White	Red	
Motor terminal	Normal	Abnormal								
Black	42.7Ω	Open or short								
White										
Red										
Drain pump(DP) 	Measure the resistance between the terminals using a tester. (Winding temperature 20°C) <table border="1" style="margin-left: 20px;"> <thead> <tr> <th>Normal</th> <th>Abnormal</th> </tr> </thead> <tbody> <tr> <td>290Ω</td> <td>Open or short</td> </tr> </tbody> </table>	Normal	Abnormal	290Ω	Open or short					
Normal	Abnormal									
290Ω	Open or short									
Drain sensor(DS) 	Measure the resistance between the terminals using a tester. Measure the resistance after 3 minutes have passed since the power supply was intercepted. (Surrounding temperature 0°C ~60°C) <table border="1" style="margin-left: 20px;"> <thead> <tr> <th>Normal</th> <th>Abnormal</th> </tr> </thead> <tbody> <tr> <td>0.6kΩ~6.0kΩ</td> <td>Open or short</td> </tr> </tbody> </table> (Refer to the thermistor)	Normal	Abnormal	0.6kΩ~6.0kΩ	Open or short					
Normal	Abnormal									
0.6kΩ~6.0kΩ	Open or short									

<Thermistor Characteristic graph>

Thermistor for lower temperature

Room temperature thermistor (TH1)
 Pipe temperature thermistor/liquid (TH2)
 Condenser/evaporator temperature thermistor (TH5)

Thermistor $R_0=15k\Omega \pm 3\%$
 Fixed number of $B=3480 \pm 2\%$

$$R_t = 15 \exp \left\{ 3480 \left(\frac{1}{273+t} - \frac{1}{273} \right) \right\}$$

0°C	15kΩ
10°C	9.6kΩ
20°C	6.3kΩ
25°C	5.4kΩ
30°C	4.3kΩ
40°C	3.0kΩ

Thermistor for drain sensor

Thermistor $R_0=6.0k\Omega \pm 5\%$
 Fixed number of $B=3390 \pm 2\%$

$$R_t = 6 \exp \left\{ 3390 \left(\frac{1}{273+t} - \frac{1}{273} \right) \right\}$$

0°C	6.0kΩ
10°C	3.9kΩ
20°C	2.6kΩ
25°C	2.2kΩ
30°C	1.8kΩ
40°C	1.3kΩ
60°C	0.6kΩ

< Thermistor for lower temperature >

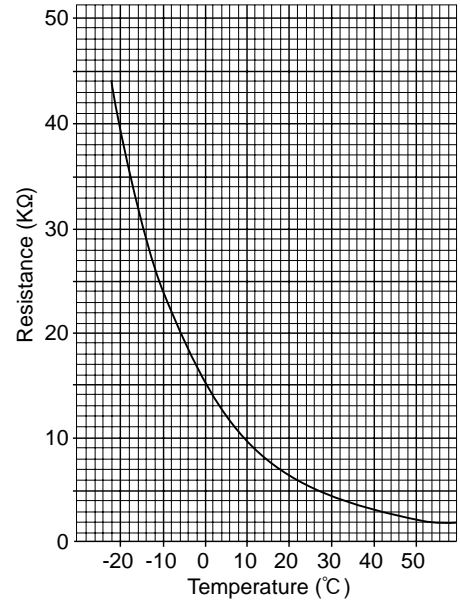

< Thermistor for drain sensor >

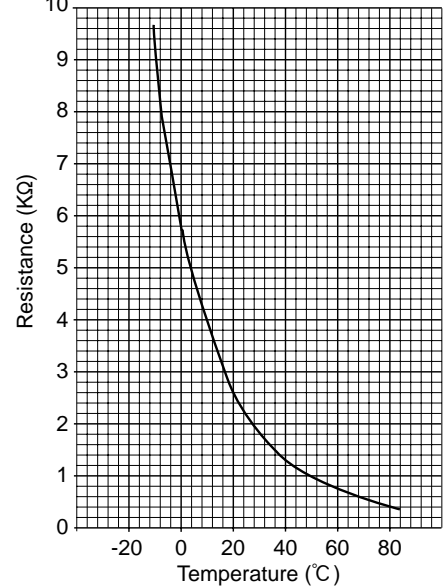

9-7-2. Indoor Controller board
PLA-RP100AA2.UK PLA-RP125AA2.UK PLA-RP140AA2.UK

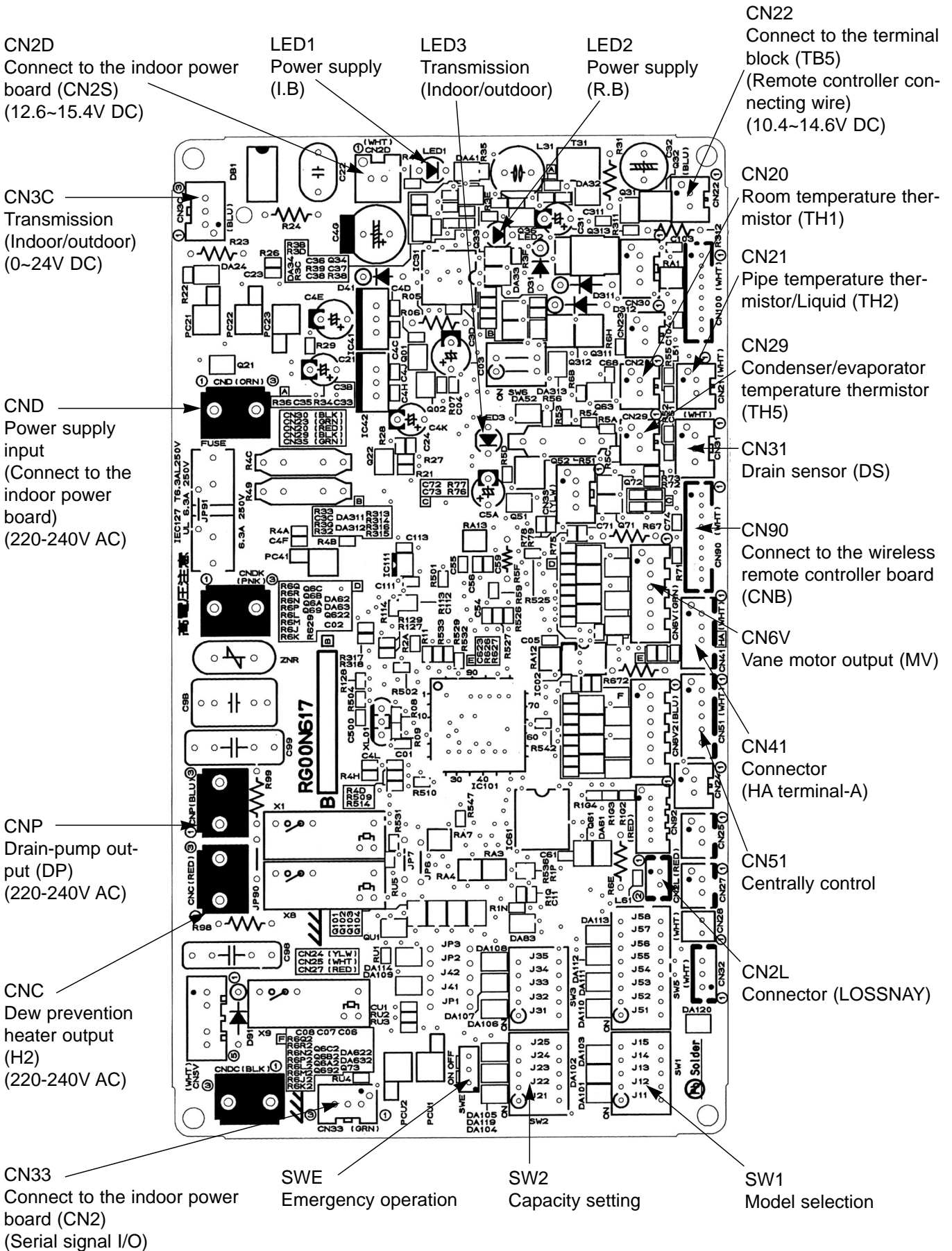

9-8. FUNCTIONS OF DIP SWITCH AND JUMPER WIRE

Each function is controlled by the dip switch and the jumper wire on control p.c. board.

(Marks in the table below) Jumper wire (○ : Short × : Open)

Jumper wire	Functions	Setting by the dip switch and jumper wire	Remarks																																												
SW1	Model settings	<table border="1"> <thead> <tr> <th>MODELS</th> <th>Manufacture/Service</th> </tr> </thead> <tbody> <tr> <td>PLA-RP. AA2</td> <td> <table border="1"> <thead> <tr> <th>1</th> <th>2</th> <th>3</th> <th>4</th> <th>5</th> <th>ON</th> </tr> </thead> <tbody> <tr> <td><input checked="" type="checkbox"/></td> <td><input checked="" type="checkbox"/></td> <td><input checked="" type="checkbox"/></td> <td><input checked="" type="checkbox"/></td> <td><input checked="" type="checkbox"/></td> <td>OFF</td> </tr> </tbody> </table> </td> </tr> </tbody> </table>	MODELS	Manufacture/Service	PLA-RP. AA2	<table border="1"> <thead> <tr> <th>1</th> <th>2</th> <th>3</th> <th>4</th> <th>5</th> <th>ON</th> </tr> </thead> <tbody> <tr> <td><input checked="" type="checkbox"/></td> <td><input checked="" type="checkbox"/></td> <td><input checked="" type="checkbox"/></td> <td><input checked="" type="checkbox"/></td> <td><input checked="" type="checkbox"/></td> <td>OFF</td> </tr> </tbody> </table>	1	2	3	4	5	ON	<input checked="" type="checkbox"/>	<input checked="" type="checkbox"/>	<input checked="" type="checkbox"/>	<input checked="" type="checkbox"/>	<input checked="" type="checkbox"/>	OFF																													
MODELS	Manufacture/Service																																														
PLA-RP. AA2	<table border="1"> <thead> <tr> <th>1</th> <th>2</th> <th>3</th> <th>4</th> <th>5</th> <th>ON</th> </tr> </thead> <tbody> <tr> <td><input checked="" type="checkbox"/></td> <td><input checked="" type="checkbox"/></td> <td><input checked="" type="checkbox"/></td> <td><input checked="" type="checkbox"/></td> <td><input checked="" type="checkbox"/></td> <td>OFF</td> </tr> </tbody> </table>	1	2	3	4	5	ON	<input checked="" type="checkbox"/>	<input checked="" type="checkbox"/>	<input checked="" type="checkbox"/>	<input checked="" type="checkbox"/>	<input checked="" type="checkbox"/>	OFF																																		
1	2	3	4	5	ON																																										
<input checked="" type="checkbox"/>	<input checked="" type="checkbox"/>	<input checked="" type="checkbox"/>	<input checked="" type="checkbox"/>	<input checked="" type="checkbox"/>	OFF																																										
SW2	Capacity settings	<table border="1"> <thead> <tr> <th>MODELS</th> <th>Manufacture/Service</th> </tr> </thead> <tbody> <tr> <td>PLA-RP100AA2</td> <td> <table border="1"> <thead> <tr> <th>1</th> <th>2</th> <th>3</th> <th>4</th> <th>5</th> <th>ON</th> </tr> </thead> <tbody> <tr> <td><input checked="" type="checkbox"/></td> <td><input checked="" type="checkbox"/></td> <td><input checked="" type="checkbox"/></td> <td><input checked="" type="checkbox"/></td> <td><input checked="" type="checkbox"/></td> <td>OFF</td> </tr> </tbody> </table> </td> </tr> <tr> <td>PLA-RP125AA2</td> <td> <table border="1"> <thead> <tr> <th>1</th> <th>2</th> <th>3</th> <th>4</th> <th>5</th> <th>ON</th> </tr> </thead> <tbody> <tr> <td><input checked="" type="checkbox"/></td> <td><input checked="" type="checkbox"/></td> <td><input checked="" type="checkbox"/></td> <td><input checked="" type="checkbox"/></td> <td><input checked="" type="checkbox"/></td> <td>OFF</td> </tr> </tbody> </table> </td> </tr> <tr> <td>PLA-RP140AA2</td> <td> <table border="1"> <thead> <tr> <th>1</th> <th>2</th> <th>3</th> <th>4</th> <th>5</th> <th>ON</th> </tr> </thead> <tbody> <tr> <td><input checked="" type="checkbox"/></td> <td><input checked="" type="checkbox"/></td> <td><input checked="" type="checkbox"/></td> <td><input checked="" type="checkbox"/></td> <td><input checked="" type="checkbox"/></td> <td>OFF</td> </tr> </tbody> </table> </td> </tr> </tbody> </table>	MODELS	Manufacture/Service	PLA-RP100AA2	<table border="1"> <thead> <tr> <th>1</th> <th>2</th> <th>3</th> <th>4</th> <th>5</th> <th>ON</th> </tr> </thead> <tbody> <tr> <td><input checked="" type="checkbox"/></td> <td><input checked="" type="checkbox"/></td> <td><input checked="" type="checkbox"/></td> <td><input checked="" type="checkbox"/></td> <td><input checked="" type="checkbox"/></td> <td>OFF</td> </tr> </tbody> </table>	1	2	3	4	5	ON	<input checked="" type="checkbox"/>	<input checked="" type="checkbox"/>	<input checked="" type="checkbox"/>	<input checked="" type="checkbox"/>	<input checked="" type="checkbox"/>	OFF	PLA-RP125AA2	<table border="1"> <thead> <tr> <th>1</th> <th>2</th> <th>3</th> <th>4</th> <th>5</th> <th>ON</th> </tr> </thead> <tbody> <tr> <td><input checked="" type="checkbox"/></td> <td><input checked="" type="checkbox"/></td> <td><input checked="" type="checkbox"/></td> <td><input checked="" type="checkbox"/></td> <td><input checked="" type="checkbox"/></td> <td>OFF</td> </tr> </tbody> </table>	1	2	3	4	5	ON	<input checked="" type="checkbox"/>	<input checked="" type="checkbox"/>	<input checked="" type="checkbox"/>	<input checked="" type="checkbox"/>	<input checked="" type="checkbox"/>	OFF	PLA-RP140AA2	<table border="1"> <thead> <tr> <th>1</th> <th>2</th> <th>3</th> <th>4</th> <th>5</th> <th>ON</th> </tr> </thead> <tbody> <tr> <td><input checked="" type="checkbox"/></td> <td><input checked="" type="checkbox"/></td> <td><input checked="" type="checkbox"/></td> <td><input checked="" type="checkbox"/></td> <td><input checked="" type="checkbox"/></td> <td>OFF</td> </tr> </tbody> </table>	1	2	3	4	5	ON	<input checked="" type="checkbox"/>	<input checked="" type="checkbox"/>	<input checked="" type="checkbox"/>	<input checked="" type="checkbox"/>	<input checked="" type="checkbox"/>	OFF	
MODELS	Manufacture/Service																																														
PLA-RP100AA2	<table border="1"> <thead> <tr> <th>1</th> <th>2</th> <th>3</th> <th>4</th> <th>5</th> <th>ON</th> </tr> </thead> <tbody> <tr> <td><input checked="" type="checkbox"/></td> <td><input checked="" type="checkbox"/></td> <td><input checked="" type="checkbox"/></td> <td><input checked="" type="checkbox"/></td> <td><input checked="" type="checkbox"/></td> <td>OFF</td> </tr> </tbody> </table>	1	2	3	4	5	ON	<input checked="" type="checkbox"/>	<input checked="" type="checkbox"/>	<input checked="" type="checkbox"/>	<input checked="" type="checkbox"/>	<input checked="" type="checkbox"/>	OFF																																		
1	2	3	4	5	ON																																										
<input checked="" type="checkbox"/>	<input checked="" type="checkbox"/>	<input checked="" type="checkbox"/>	<input checked="" type="checkbox"/>	<input checked="" type="checkbox"/>	OFF																																										
PLA-RP125AA2	<table border="1"> <thead> <tr> <th>1</th> <th>2</th> <th>3</th> <th>4</th> <th>5</th> <th>ON</th> </tr> </thead> <tbody> <tr> <td><input checked="" type="checkbox"/></td> <td><input checked="" type="checkbox"/></td> <td><input checked="" type="checkbox"/></td> <td><input checked="" type="checkbox"/></td> <td><input checked="" type="checkbox"/></td> <td>OFF</td> </tr> </tbody> </table>	1	2	3	4	5	ON	<input checked="" type="checkbox"/>	<input checked="" type="checkbox"/>	<input checked="" type="checkbox"/>	<input checked="" type="checkbox"/>	<input checked="" type="checkbox"/>	OFF																																		
1	2	3	4	5	ON																																										
<input checked="" type="checkbox"/>	<input checked="" type="checkbox"/>	<input checked="" type="checkbox"/>	<input checked="" type="checkbox"/>	<input checked="" type="checkbox"/>	OFF																																										
PLA-RP140AA2	<table border="1"> <thead> <tr> <th>1</th> <th>2</th> <th>3</th> <th>4</th> <th>5</th> <th>ON</th> </tr> </thead> <tbody> <tr> <td><input checked="" type="checkbox"/></td> <td><input checked="" type="checkbox"/></td> <td><input checked="" type="checkbox"/></td> <td><input checked="" type="checkbox"/></td> <td><input checked="" type="checkbox"/></td> <td>OFF</td> </tr> </tbody> </table>	1	2	3	4	5	ON	<input checked="" type="checkbox"/>	<input checked="" type="checkbox"/>	<input checked="" type="checkbox"/>	<input checked="" type="checkbox"/>	<input checked="" type="checkbox"/>	OFF																																		
1	2	3	4	5	ON																																										
<input checked="" type="checkbox"/>	<input checked="" type="checkbox"/>	<input checked="" type="checkbox"/>	<input checked="" type="checkbox"/>	<input checked="" type="checkbox"/>	OFF																																										
J41 J42	Pair number setting with wireless remote controller	<table border="1"> <thead> <tr> <th rowspan="2">Wireless remote controller setting</th> <th colspan="2">Control PCB setting</th> </tr> <tr> <th>J41</th> <th>J42</th> </tr> </thead> <tbody> <tr> <td>0</td> <td>○</td> <td>○</td> </tr> <tr> <td>1</td> <td>×</td> <td>○</td> </tr> <tr> <td>2</td> <td>○</td> <td>×</td> </tr> <tr> <td>3 ~ 9</td> <td>×</td> <td>×</td> </tr> </tbody> </table>	Wireless remote controller setting	Control PCB setting		J41	J42	0	○	○	1	×	○	2	○	×	3 ~ 9	×	×	<p><Settings at time of factory shipment> Wireless remote controller: 0 Control PCB: ○ (for both J41 and J42) Four pair number settings are supported. The pair number settings of the wireless remote controller and indoor control PCB (J41/J42) are given in the table on the left. ('×' in the table indicates the jumper line is disconnected.)</p>																											
Wireless remote controller setting	Control PCB setting																																														
	J41	J42																																													
0	○	○																																													
1	×	○																																													
2	○	×																																													
3 ~ 9	×	×																																													
JP1	Unit type setting	<table border="1"> <thead> <tr> <th>Model</th> <th>JP1</th> </tr> </thead> <tbody> <tr> <td>Without TH5</td> <td>○</td> </tr> <tr> <td>With TH5</td> <td>×</td> </tr> </tbody> </table>	Model	JP1	Without TH5	○	With TH5	×	There is no jumper (JP1) because these models have the cond./eva. temperature thermistor (TH5).																																						
Model	JP1																																														
Without TH5	○																																														
With TH5	×																																														
JP3	Indoor controller board type setting	<table border="1"> <thead> <tr> <th>Indoor controller board type</th> <th>JP3</th> </tr> </thead> <tbody> <tr> <td>Factory shipment</td> <td>○</td> </tr> <tr> <td>Service parts</td> <td>○</td> </tr> </tbody> </table>	Indoor controller board type	JP3	Factory shipment	○	Service parts	○																																							
Indoor controller board type	JP3																																														
Factory shipment	○																																														
Service parts	○																																														

PLA-RP100AA2.UK PLA-RP125AA2.UK PLA-RP140AA2.UK

Be careful on removing heavy parts.

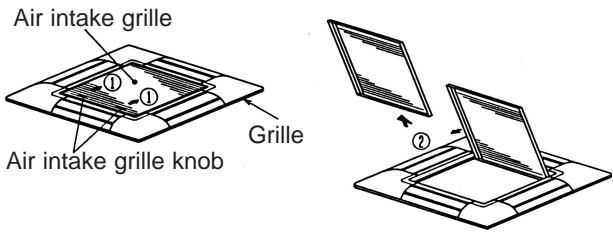
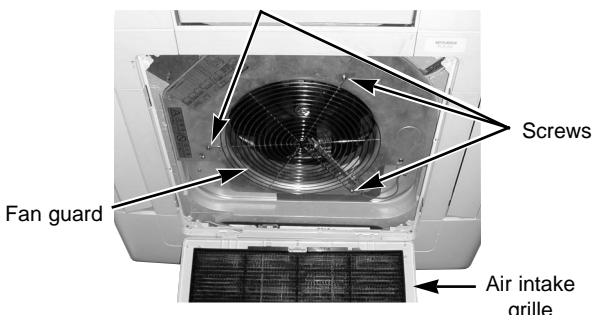
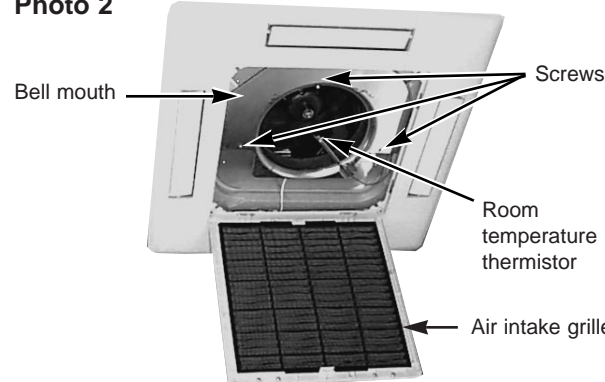
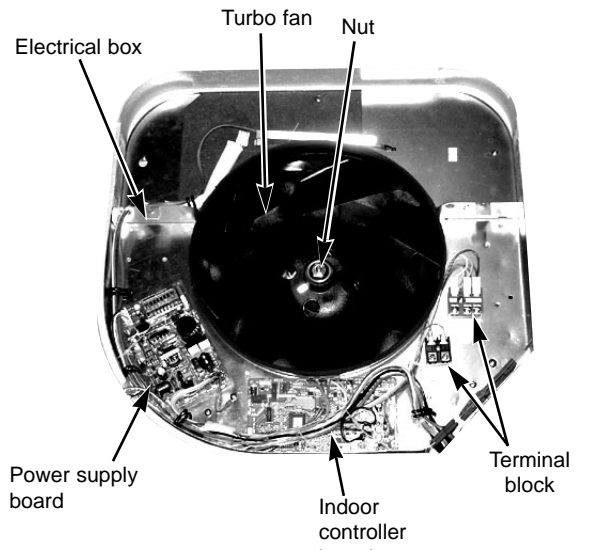
OPERATING PROCEDURE	PHOTOS & ILLUSTRATIONS
<p>1. Removing the air intake grille</p> <ol style="list-style-type: none"> (1) Slide the knob of air intake grille toward the arrow ① to open the air intake grille. (2) Remove drop prevention hook from the panel. (3) Slide the shaft in the hinge to the direction of the arrow ② and remove the air intake grille. 	<p>Figure 1</p> 
<p>2. Removing the fan guard</p> <ol style="list-style-type: none"> (1) Open the air intake grille. (2) Remove the 3 screws of fan guard. 	<p>Photo 1</p> 
<p>3. Removing the room temperature thermistor</p> <ol style="list-style-type: none"> (1) Remove the fan guard.(See photo 1) (2) Remove the screw in the room temperature thermistor holder to remove the holder and the room temperature thermistor. (3) Remove the 1 screw from the bell mouth, and unscrew the other 2 screws (fix to the oval hole which has a different diameter) to remove the bell mouth. (4) Remove the holder claw, and remove the room temperature thermistor and holder. (5) Disconnect the connector (Red) from the indoor controller board. 	<p>Photo 2</p> 
<p>4. Removing the electrical box</p> <ol style="list-style-type: none"> (1) Remove the fan guard. (See photo 1) (2) Remove the lead wire of the vane motor from the clamp, and disconnect the white connector (10P). (3) Remove the room temperature thermistor with the holder. (4) Remove the bell mouth.(See photo 1) (5) Disconnect the relay connector in the electrical box. White (3P)(CN4)/white (5P)(CN3)for fan motor White (2P) for pipe temperature detecting thermistor Black (2P) for condenser/evaporator pipe temperature detecting thermistor Blue (2P) for drain pump White (3P) for drain sensor (6) Remove the 3 screws of the electrical box and loosen the other 2 screws to remove the box. <p><Electrical parts in the electrical box></p> <ul style="list-style-type: none"> Indoor controller board Power supply board Terminal block (TB4)(TB5) 	<p>Photo 3</p> 

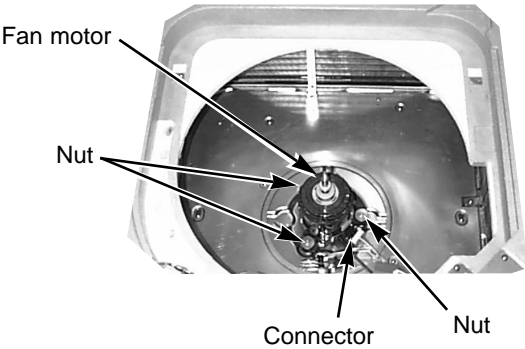
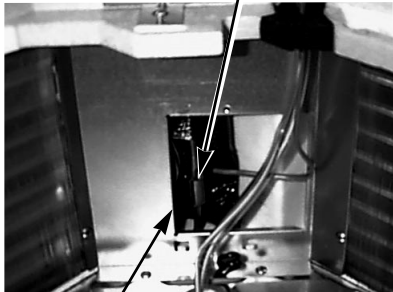
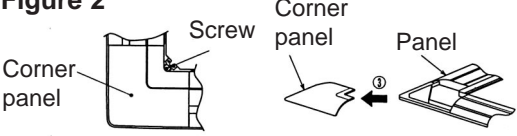
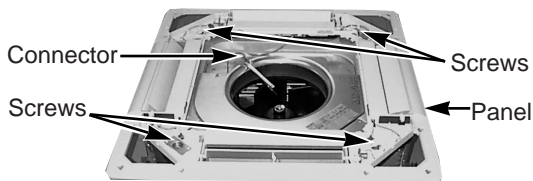
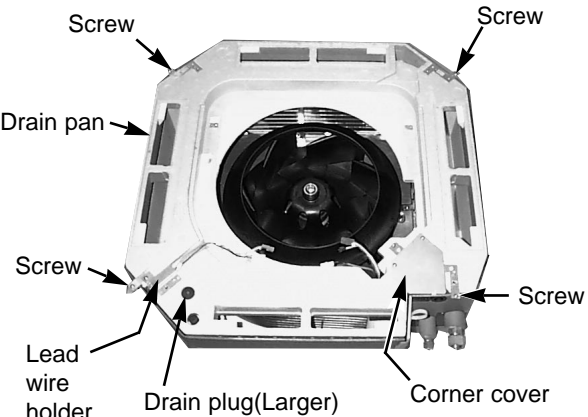

OPERATING PROCEDURE	PHOTOS & ILLUSTRATIONS
<p>5 Removing the fan motor</p> <ol style="list-style-type: none">(1) Remove the fan guard.(See photo 1)(2) Remove the bell mouth.(See photo 1)(3) Remove the electrical box.(See photo 2)(4) Remove the turbo fan nut.(5) Pull out the turbo fan.(6) Disconnect the connector of the fan motor lead wire.(7) Remove the 3 nuts of the fan motor.	<p>Photo 4</p>  <p>Fan motor</p> <p>Nut</p> <p>Connector</p> <p>Nut</p>
<p>6. Removing the pipe temperature thermistor and condenser evaporator temperature thermistor</p> <ol style="list-style-type: none">(1) Remove the fan guard.(See photo 1)(2) Remove the bell mouth.(See photo 2)(3) Remove the electrical box.(See photo 3)(4) Remove the turbo fan.(5) Remove the screw of the service panel.(6) Remove the service panel.(7) Remove the pipe temperature thermistor which is inserted into the holder installed to the thin copper pipe.(8) Disconnect the 2-pin white connector.(CN21) <p>[Condenser/ evaporator temperature thermistor]</p> <ol style="list-style-type: none">(9) Remove the drain pan. (See Photo 7)(10) Remove the thermistor which is installed into the holder installed to the indoor coil.(11) Disconnect the 2-pin black connector. (CN29)	<p>Photo 5</p>  <p>Pipe temperature thermistor</p> <p>Service access</p>
<p>7. Removing the panel</p> <ol style="list-style-type: none">(1) Remove the air intake grille.(See figure 1) <p>Corner panel (See figure 2)</p> <ol style="list-style-type: none">(1) Remove the corner screw.(2) Slide the corner panel to the direction of the arrow ③, and remove the corner panel. <p>Panel (See photo 6)</p> <ol style="list-style-type: none">(1) Disconnect the connector that connects with the unit.(2) Remove the 2 screws from the panel and loosen another 2 screws, which fix to the oval holes, have different diameters.(3) Rotate the panel a little to remove the panel.	<p>Figure 2</p>  <p>Corner panel</p> <p>Screw</p> <p>Panel</p> <p>Photo 6</p>  <p>Connector</p> <p>Screws</p> <p>Screws</p> <p>Panel</p>
<p>8. Removing the drain pan</p> <ol style="list-style-type: none">(1) Remove the panel. (See photo 6)(2) Remove the drain plug (Larger one), drain the remaining water in the drain pan.(3) Remove the corner cover. (2 screws)(4) Remove the bell mouth. (See photo 2)(5) Remove the electrical box. (See photo 3)(6) Remove the lead wire holder. (1 screw)(7) Remove the 4 screws and pull out the drain pan. * Pull out the left and right of the pan gradually. Be careful not to crack or damage the pan.	<p>Photo 7</p>  <p>Screw</p> <p>Screw</p> <p>Drain pan</p> <p>Screw</p> <p>Screw</p> <p>Lead wire holder</p> <p>Drain plug(Larger)</p> <p>Corner cover</p>

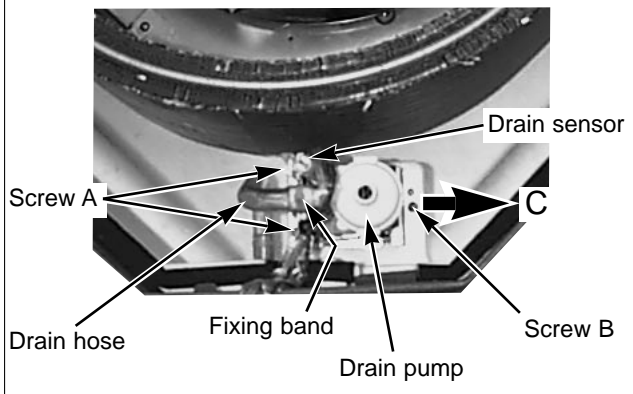
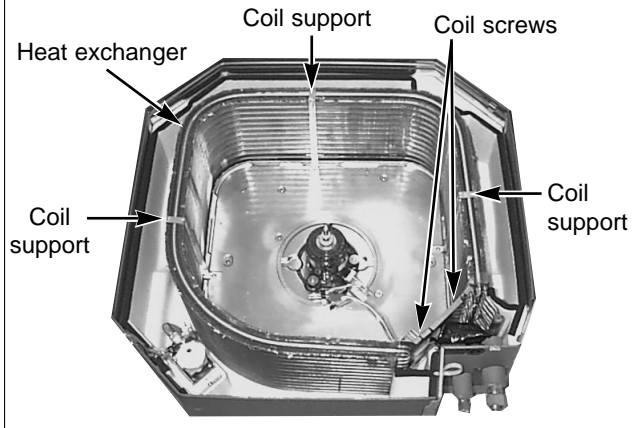
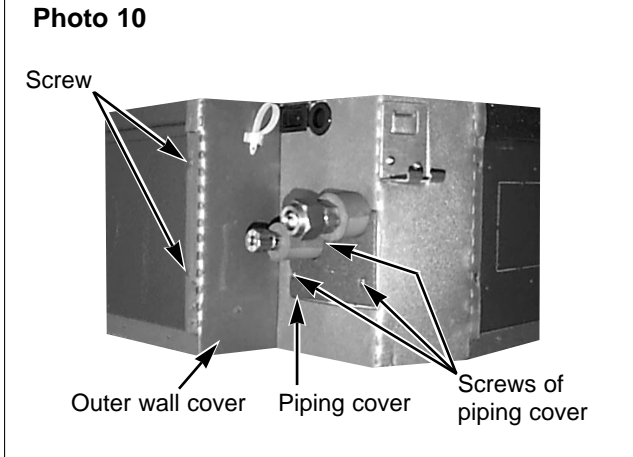

OPERATING PROCEDURE	PHOTOS & ILLUSTRATIONS
<p>9. Removing the drain pump and drain sensor</p> <ol style="list-style-type: none">(1) Remove the panel. (See photo 6)(2) Remove the fan guard. (See photo 1)(3) Remove the bell mouth. (See photo 2)(4) Remove the electrical box. (See photo 3)(5) Cut the drain hose band with scissors and pull out the drain hose from the drain pump.(6) loosen the screw(2 screws) and remove the screw B (1 screw).Slide the drain pump in the direction of the arrow C and remove it.(7) Remove the drain sensor with its holder from the drain pump.	<p>Photo 8</p>  <p>Drain sensor Screw A Drain hose Fixing band Drain pump Screw B C</p>
<p>10. Removing the heat exchanger</p> <ol style="list-style-type: none">(1) Remove the panel. (See photo 6)(2) Remove the fan guard. (See photo 1)(3) Remove the bell mouth. (See photo 2)(4) Remove the electrical box. (See photo 3)(5) Remove the drain pan. (See photo 7)(6) Remove the turbo fan. (See photo 4)(7) Remove the 3 screws of the piping cover, and pull out piping cover.(8) Remove the 4 screws of the outer wall cover, and pull out the outer wall cover.(9) Remove the screw of the coil support.(10) Remove the 2 screws of the coil.(11) Pull out the heat exchanger.	<p>Photo 9</p>  <p>Heat exchanger Coil support Coil screws Coil support Coil support</p> <p>Photo 10</p>  <p>Screw Outer wall cover Piping cover Screws of piping cover</p>

PANEL PARTS

PLA-RP100AA2.UK

PLA-RP125AA2.UK

PLA-RP140AA2.UK

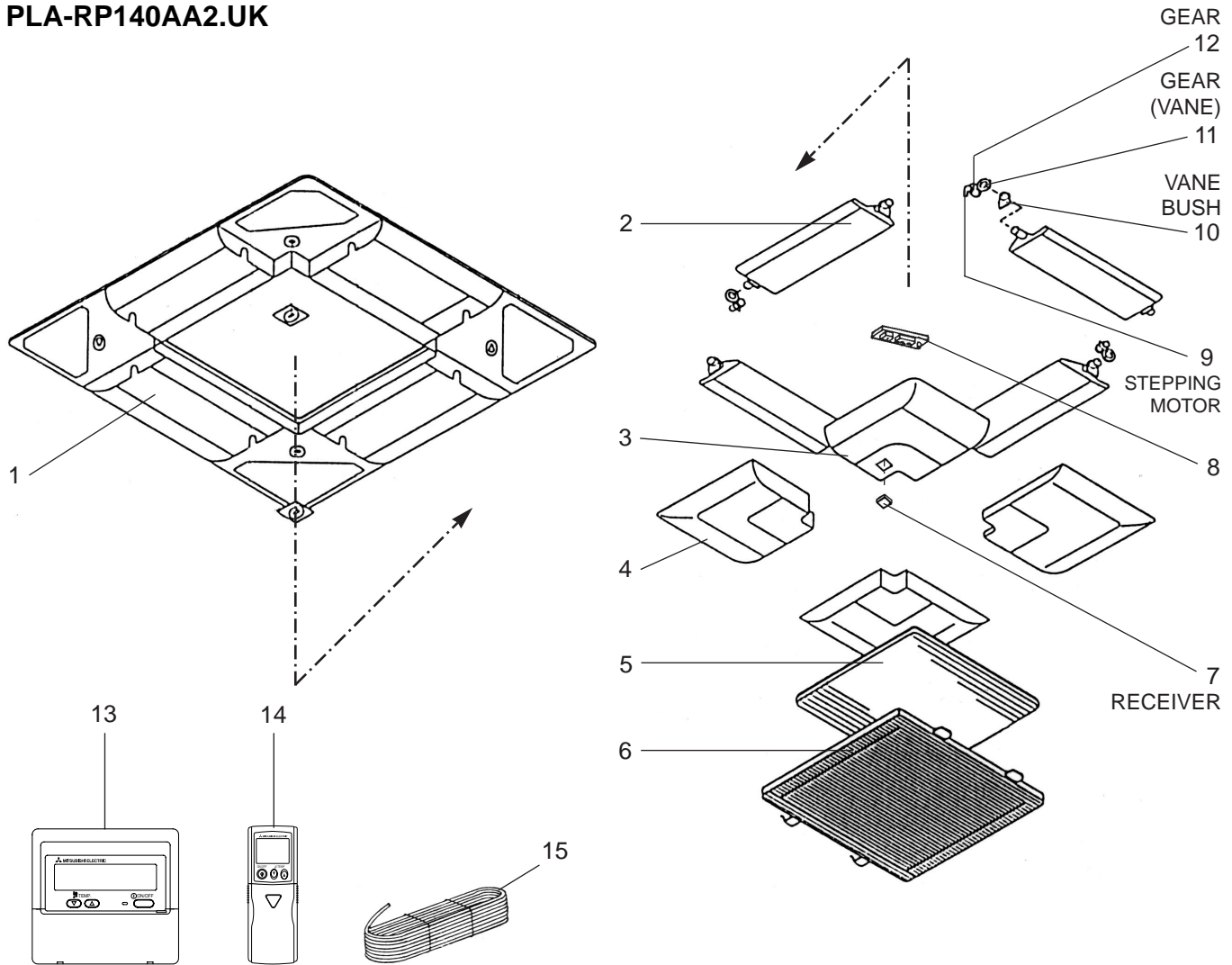

No.	Parts No.	Parts Name	Specification	Q'ty / set		Remarks (Drawing No.)	Wiring Diagram Symbol	Recommended Q'ty	Price	
				PLA-RP100*125*140AA2.UK					Unit	Amount
				WIRED	WIRELESS					
1	S70 E10 003	AIR OUTLET GRILLE		1	1					
2	S70 E01 002	VANE ASSY		4	4					
3	S70 E01 638	CORNER PANEL		1	2					
4	S70 E00 638	CORNER PANEL		3	2					
5	S70 E00 500	L.L FILTER-A		1	1					
6	S70 E00 691	GRILLE ASSY		1	1					
7	S70 24K 658	RECEIVER			1		RU			
8	S70 E00 317	WIRELESS ADAPTER			1		W.B			
9	S70 E00 223	STEPPING MOTOR		4	4		MV			
10	S70 E00 063	VANE BUSH		8	8					
11	S70 E00 040	GEAR (VANE)		4	4					
12	S70 E01 040	GEAR		4	4					
13	S70 KW1 713	REMOTE CONTROLLER ASSY	PAR-21MAA-E	1			R.B			
14	S70 E15 714	WIRELESS REMOTE CONTROLLER ASSY	PAR-SL97A-E		1					
15	S70 58A 246	CORD		1						

FUNCTIONAL PARTS
PLA-RP100AA2.UK
PLA-RP125AA2.UK
PLA-RP140AA2.UK

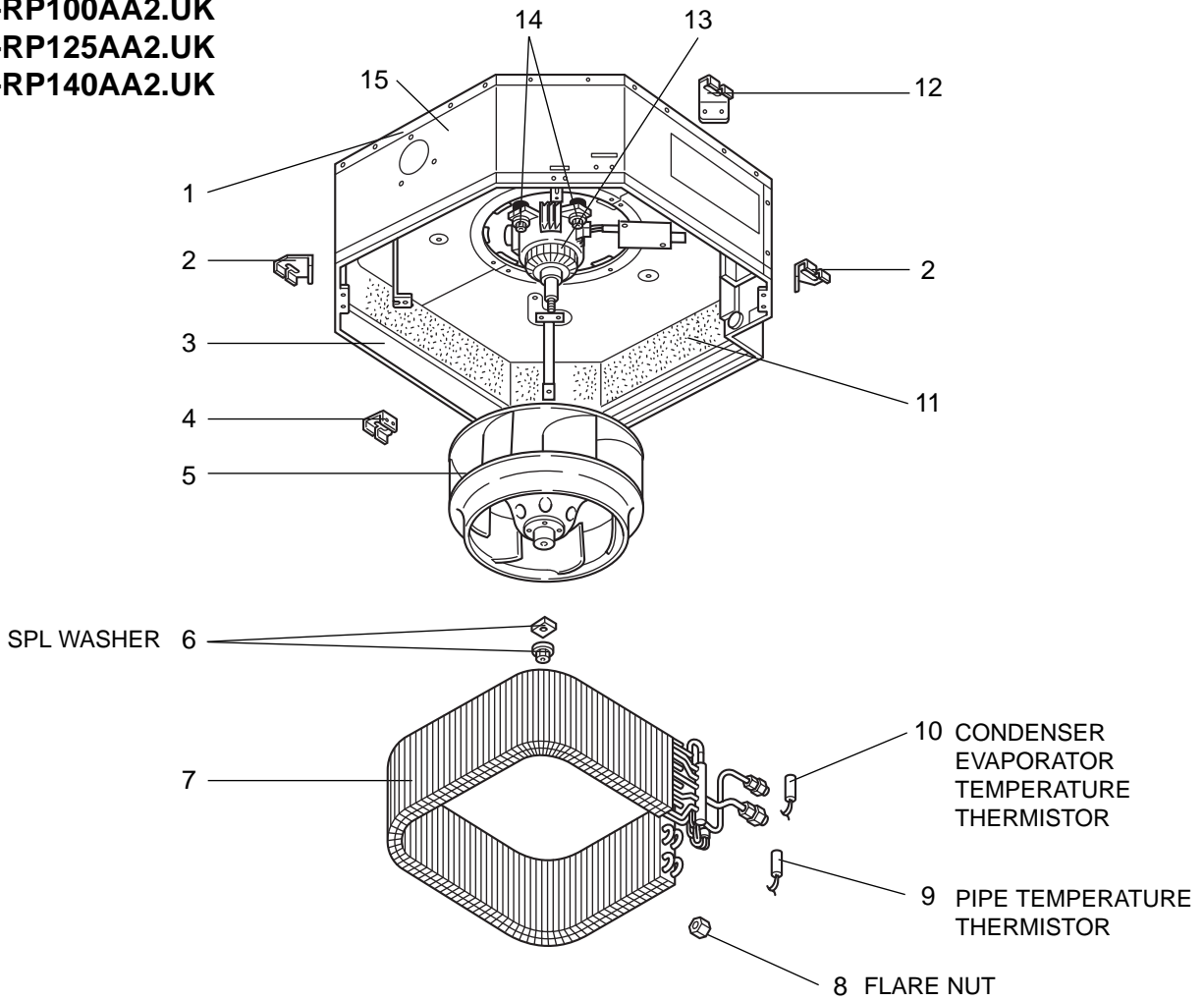

No.	Parts No.	Parts Name	Specifi- cation	Q'ty / set		Remarks (Drawing No.)	Wiring Diagram Symbol	Recom- mended Q'ty	Price	
				PLA-RP•AA2.UK					Unit	Amount
				100	125,140					
1	S70 K01 687	BASE		1	1					
2	S70 E01 130	LEG		2	2					
3	S70 007 688	DRUM 1 ASSY		1	1					
4	S70 E00 130	LEG		1	1					
5	S70 E01 114	TURBO FAN		1	1					
6	S70 08K 097	SPL WASHER		1	1					
7	S70 K19 480	HEAT EXCHANGER		1	1					
8	S70 E16 097	FLARE NUT	3/4"	1	1					
9	S70 17J 202	PIPE TEMPERATURE THERMISTOR		1	1		TH2			
10	S70 E20 202	CONDENSER EVAPORATOR TEMPERATURE THERMISTOR		1	1		TH5			
11	S70 E02 659	INNER COVER		1	1					
12	S70 E02 130	LEG		1	1					
13	S70 K10 762	FAN MOTOR	EHD01A120MS	1	1		MF			
14	S70 K10 105	MOTOR MOUNT		3	3					
15	S70 008 688	DRUM 2 ASSY		1	1					

FUNCTIONAL PARTS
PLA-RP100AA2.UK
PLA-RP125AA2.UK
PLA-RP140AA2.UK

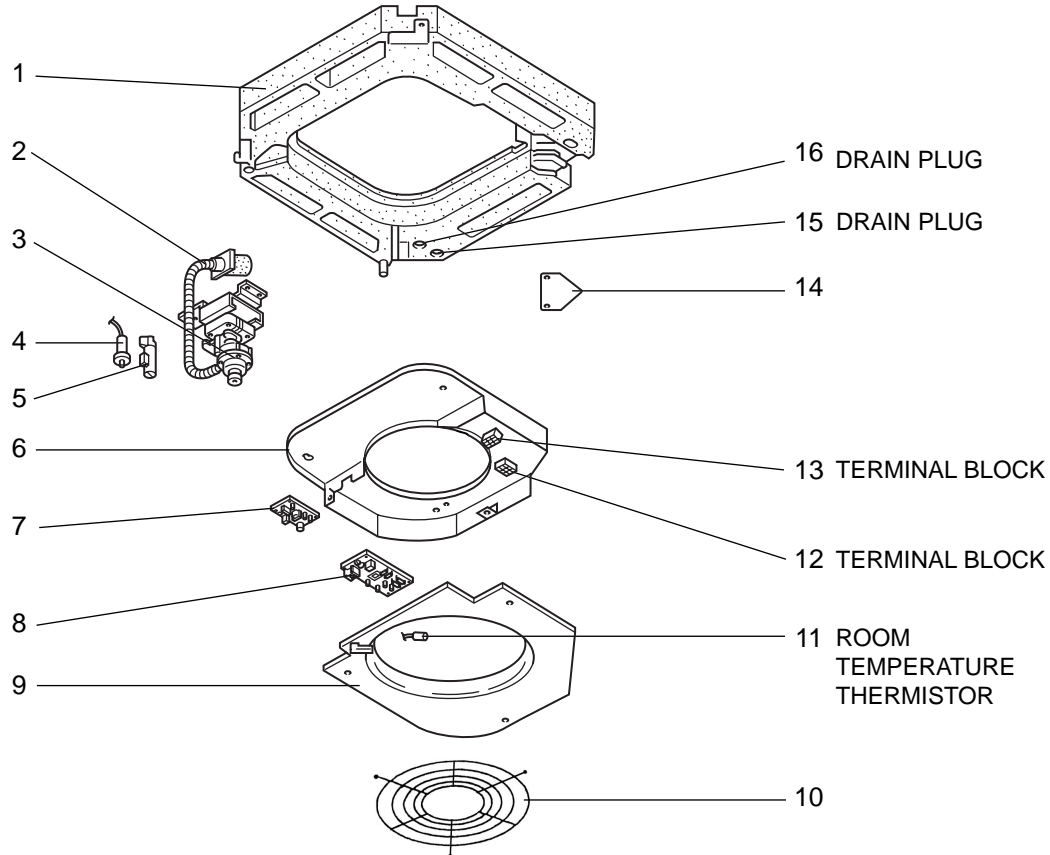

Part numbers that are circled are not shown in the figure.

No.	Parts No.	Parts Name	Specification	Q'ty / set	Remarks (Drawing No.)	Wiring Diagram Symbol	Recom- mended Q'ty	Price	
				PLA-RP100*125*140AA2.UK				Unit	Amount
1	S70 E01 529	DRAIN PAN		1					
2	S70 29H 523	DRAIN SOCKET		1					
3	S70 E02 355	DRAIN PUMP		1		DP			
4	S70 E00 266	DRAIN SENSOR		1		DS			
5	S70 31K 241	DRAIN SENSOR HOLDER		1					
6	S70 K00 501	ELECTRICAL CONTROL BOX		1					
7	S70 K10 313	POWER BOARD		1		P.B			
8	S70 K50 310	INDOOR CONTROLLER BOARD		1		I.B			
9	S70 K03 503	CONTROL COVER ASSY		1					
10	S70 E10 675	FAN GUARD		1					
11	S70 E00 202	ROOM TEMPERATURE THERMISTOR		1		TH1			
12	S70 512 716	TERMINAL BLOCK	2P (1, 2)	1		TB5			
13	S70 K01 716	TERMINAL BLOCK	3P (S1, S2, S3)	1		TB4			
14	S70 001 663	CORNER COVER		1					
15	S70 A41 524	DRAIN PLUG		1					
16	S70 A48 524	DRAIN PLUG		1					
17	S70 A41 523	DRAIN HOSE ASSY		1					
18	S70 K00 529	REACTOR(NOISE FILTER)		1		DCL			

PANEL PARTS
 PLA-RP100AA2.UK
 PLA-RP125AA2.UK
 PLA-RP140AA2.UK

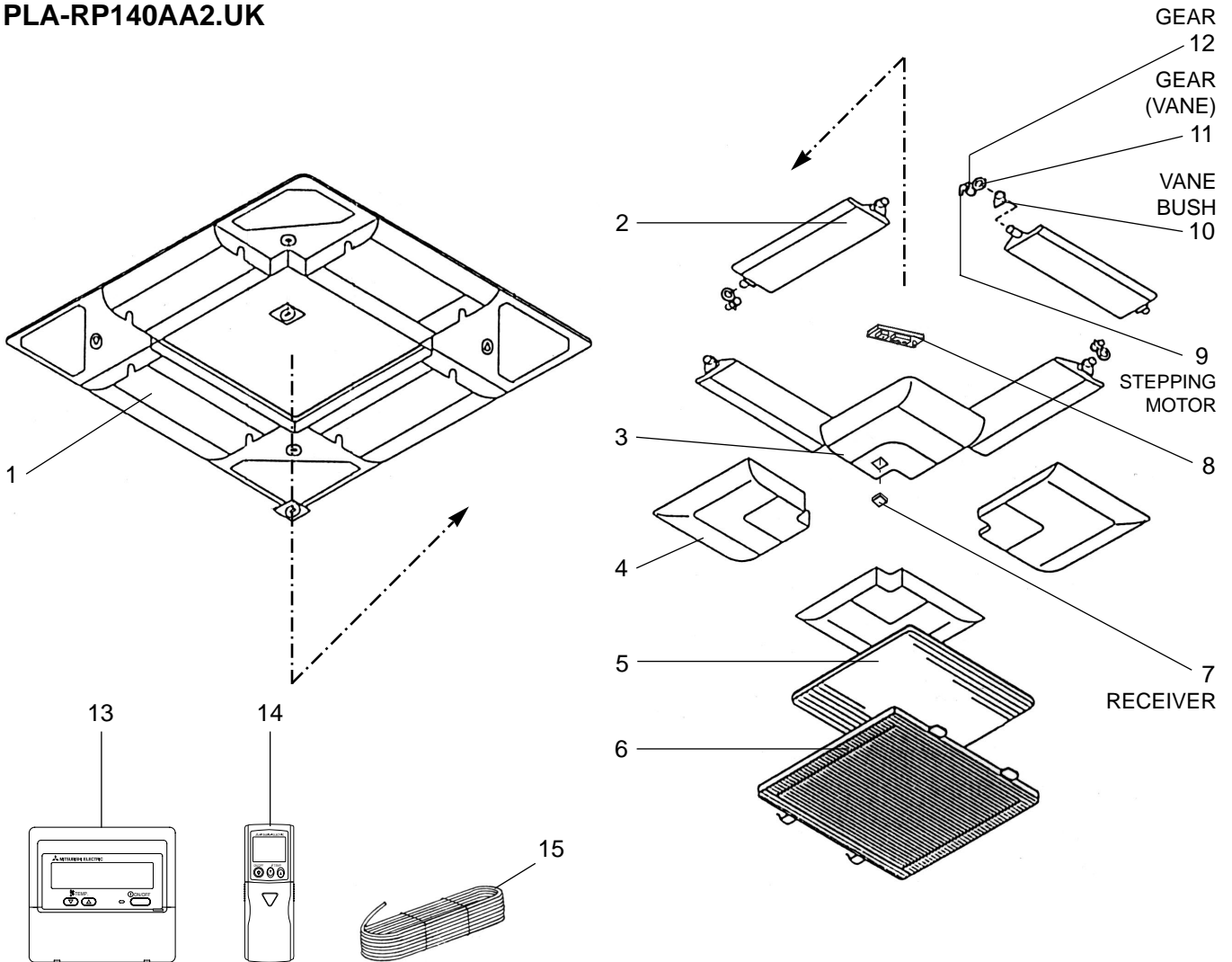

No.	RoHS	Parts No.	Parts Name	Specifi- cation	Q'ty / set		Remarks (Drawing No.)	Wiring Diagram Symbol	Recom- mended Q'ty	Price	
					PLA-RP100•125•140AA2.UK					Unit	Amount
					WIRED	WIRELESS					
1	G	S70 E10 003	AIR OUTLET GRILLE		1	1					
2	G	S70 E01 002	VANE ASSY		4	4					
3	G	S70 E01 638	CORNER PANEL		1	2					
4	G	S70 E00 638	CORNER PANEL		3	2					
5	G	S70 E00 500	L.L FILTER-A		1	1					
6	G	S70 E00 691	GRILLE ASSY		1	1					
7	G	S70 24K 658	RECEIVER			1		RU			
8	G	S70 E00 317	WIRELESS ADAPTER			1		W.B			
9	G	S70 E00 223	STEPPING MOTOR		4	4		MV			
10	G	S70 E00 063	VANE BUSH		8	8					
11	G	S70 E00 040	GEAR (VANE)		4	4					
12	G	S70 E01 040	GEAR		4	4					
13	G	S70 KW1 713	REMOTE CONTROLLER ASSY	PAR-21MAA-E	1			R.B			
14	G	S70 E15 714	WIRELESS REMOTE CONTROLLER ASSY	PAR-SL97A-E		1					
15	G	S70 58A 246	CORD		1						

FUNCTIONAL PARTS
PLA-RP100AA2.UK
PLA-RP125AA2.UK
PLA-RP140AA2.UK

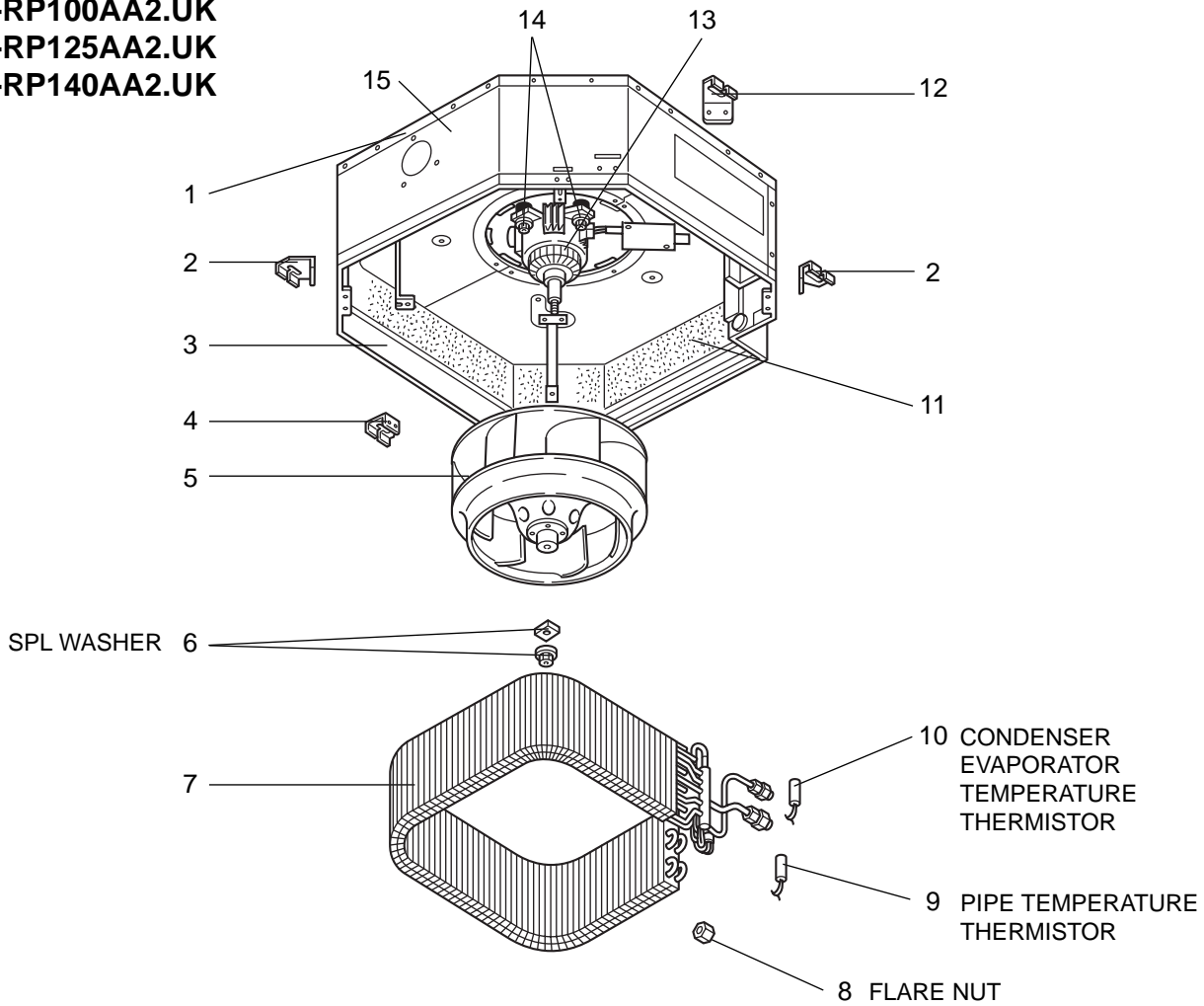

No.	ROHS	Parts No.	Parts Name	Specifi- cation	Q'ty / set		Remarks (Drawing No.)	Wiring Diagram Symbol	Recom- mended Q'ty	Price	
					PLA-RP•AA2.UK					Unit	Amount
					100	125,140					
1	G	S70 K01 687	BASE		1	1					
2	G	S70 E01 130	LEG		2	2					
3	G	S70 007 688	DRUM 1 ASSY		1	1					
4	G	S70 E00 130	LEG		1	1					
5	G	S70 E01 114G	TURBO FAN		1	1					
6	G	S70 08K 097	SPL WASHER		1	1					
7	G	S70 K19 480	HEAT EXCHANGER		1	1					
8	G	S70 E16 097	FLARE NUT	3/4"	1	1					
9	G	S70 17J 202	PIPE TEMPERATURE THERMISTOR		1	1		TH2			
10	G	S70 E20 202	CONDENSER EVAPORATOR TEMPERATURE THERMISTOR		1	1		TH5			
11	G	S70 E02 659	INNER COVER		1	1					
12	G	S70 E02 130	LEG		1	1					
13	G	S70 K10 762	FAN MOTOR	EHD01A120MS	1	1		MF			
14	G	S70 K10 105	MOTOR MOUNT		3	3					
15	G	S70 008 688	DRUM 2 ASSY		1	1					

FUNCTIONAL PARTS
PLA-RP100AA2.UK
PLA-RP125AA2.UK
PLA-RP140AA2.UK

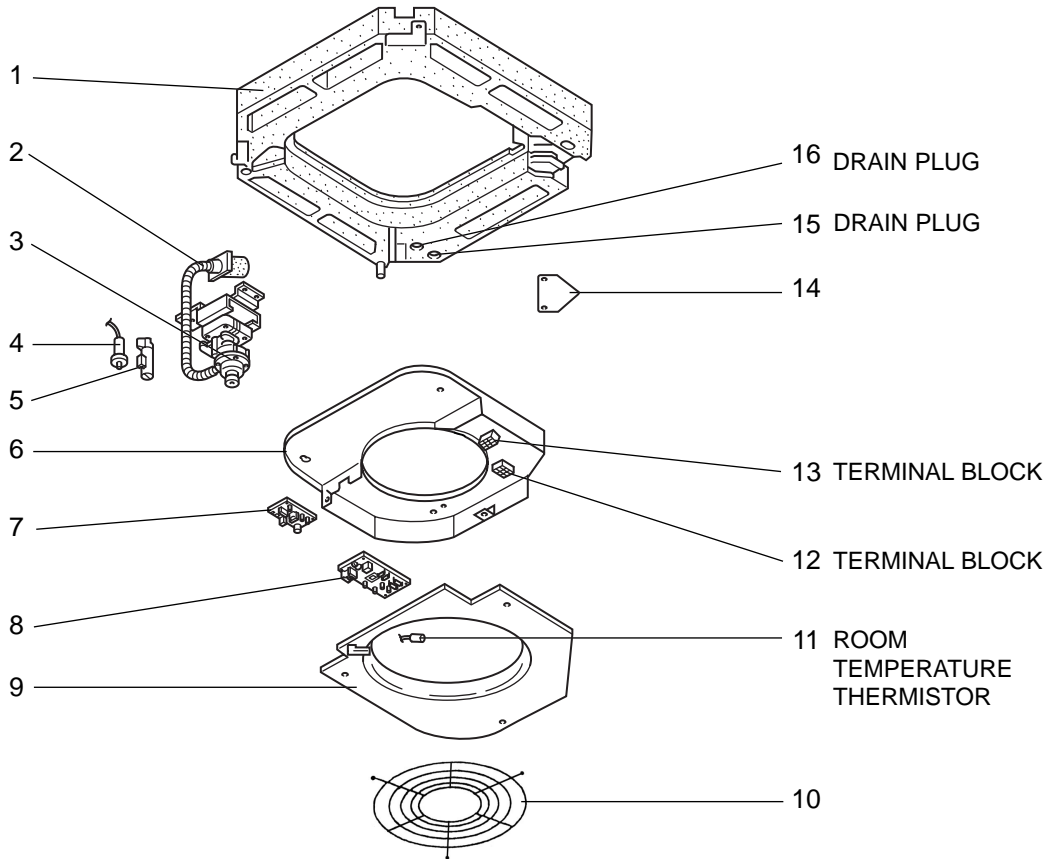

Part numbers that are circled are not shown in the figure.

No.	RoHS	Parts No.	Parts Name	Specification	Q'ty / set	Remarks (Drawing No.)	Wiring Diagram Symbol	Recom- mended Q'ty	Price	
					PLA-RP100-125-140 AA2.UK				Unit	Amount
1	G	S70 E01 529	DRAIN PAN		1					
2	G	S70 29H 523	DRAIN SOCKET		1					
3	G	S70 E02 355	DRAIN PUMP		1		DP			
4	G	S70 E00 266	DRAIN SENSOR		1		DS			
5	G	S70 31K 241	DRAIN SENSOR HOLDER		1					
6	G	S70 K00 501	ELECTRICAL CONTROL BOX		1					
7	G	S70 K10 313	POWER BOARD		1		P.B			
8	G	S70 K50 310	INDOOR CONTROLLER BOARD		1		I.B			
9	G	S70 K03 503	CONTROL COVER ASSY		1					
10	G	S70 E10 675G	FAN GUARD		1					
11	G	S70 E00 202	ROOM TEMPERATURE THERMISTOR		1		TH1			
12	G	S70 512 716	TERMINAL BLOCK	2P (1, 2)	1		TB5			
13	G	S70 K01 716	TERMINAL BLOCK	3P (S1, S2, S3)	1		TB4			
14	G	S70 001 663	CORNER COVER		1					
15	G	S70 A41 524	DRAIN PLUG		1					
16	G	S70 A48 524	DRAIN PLUG		1					
⑰	G	S70 A41 523	DRAIN HOSE ASSY		1					
⑱	G	S70 K00 529	REACTOR(NOISE FILTER)		1		DCL			

Mr. SLIM™

 **mitsubishi electric corporation**

HEAD OFFICE : TOKYO BLDG., 2-7-3, MARUNOUCHI, CHIYODA-KU, TOKYO 100-8310, JAPAN