

# Air-Conditioners

## PU(H)-P·HA

### INSTALLATION MANUAL

For safe and correct use, read this manual and the indoor unit installation manual thoroughly before installing the air-conditioner unit.

**FOR INSTALLER**

### INSTALLATIONSHANDBUCH

Aus Sicherheitsgründen und zur richtigen Verwendung vor der Installation die vorliegende Bedienungsanleitung und die Installationsanleitung der Innenanlage gründlich durchlesen die Klimaanlage.

**FÜR INSTALLATEURE**

### MANUEL D'INSTALLATION

Avant d'installer le climatiseur, lire attentivement ce manuel, ainsi que le manuel d'installation de l'appareil intérieur pour une utilisation sûre et correcte.

**POUR L'INSTALLATEUR**

### INSTALLATIEHANDLEIDING

Lees deze handleiding en de installatiehandleiding van het binnenapparaat zorgvuldig door voordat u met het installeren van de airconditioner begint.

**VOOR DE INSTALLATEUR**

### MANUAL DE INSTALACIÓN

Para un uso correcto y seguro, lea detalladamente este manual y el manual de instalación de la unidad interior antes de instalar la unidad de aire acondicionado.

**PARA EL INSTALADOR**

### MANUALE DI INSTALLAZIONE

Per un uso sicuro e corretto, leggere attentamente il presente manuale ed il manuale d'installazione dell'unità interna prima di installare il condizionatore d'aria.

**PER L'INSTALLATORE**

### ΕΓΧΕΙΡΙΔΙΟ ΟΔΗΓΙΩΝ ΕΓΚΑΤΑΣΤΑΣΗΣ

Για σωστή και ασφαλή χρήση, διαβάστε προσεκτικά αυτό το εγχειρίδιο καθώς και το εγχειρίδιο εγκατάστασης της εσωτερικής μονάδας, προτού εγκαταστήσετε τη μονάδα του κλιματιστικού.

**ΓΙΑ ΑΥΤΟΝ ΠΟΥ ΚΑΝΕΙ ΤΗΝ ΕΓΚΑΤΑΣΤΑΣΗ**

### MANUAL DE INSTALAÇÃO

Para uma utilização segura e correcta, leia atentamente este manual e o manual de instalação da unidade interior antes de instalar o aparelho de ar condicionado.

**PARA O INSTALADOR**

### INSTALLATIONSMANUAL

Læs af sikkerhedshensyn denne manual samt manualen til installation af indendørsenheden grundigt, før du installerer klimaanlægget.

**TIL INSTALLATØREN**

### INSTALLATIONSMANUAL

Läs bruksanvisningen och inomhusenhetens installationshandbok noga innan luftkonditioneringen installeras så att den används på ett säkert och korrekt sätt.

**FÖR INSTALLATÖREN**

### MONTAJ ELKİTABI

Emniyetli ve doğru kullanım için, klima cihazını monte etmeden önce bu kılavuzu ve iç ünite montaj kılavuzunu tamamiyla okuyun.

**MONTÖR İÇİN**

### РУКОВОДСТВО ПО УСТАНОВКЕ

Для обеспечения безопасной и надлежащей эксплуатации внимательно прочтите данное руководство и руководство по установке внутреннего прибора перед установкой кондиционера.

**ДЛЯ УСТАНОВИТЕЛЯ****English****Deutsch****Français****Nederlands****Español****Italiano****Ελληνικά****Português****Dansk****Svenska****Türkçe****Русский**

# Contents

1. Safety precautions	2	6. Electrical work	7
2. Installation location	3	7. Test run	8
3. Installing the outdoor unit	4	8. Special Functions	9
4. Installing the refrigerant piping	5	9. System control (Fig. 9-1)	9
5. Drainage piping work	7		

## ⚠ Caution:

- Do not vent R410A into the Atmosphere:
- R410A is a Fluorinated Greenhouse gas, covered by the Kyoto Protocol, with a Global Warming Potential (GWP)=1975.

## 1. Safety precautions

- ▶ Before installing the unit, make sure you read all the "Safety precautions".
- ▶ This equipment does not comply with the relevant technical standard for the limitation of flicker and this may cause adverse effects on other electrical appliances. Please provide an exclusive circuit for the air conditioner and ensure the max. impedance in this manual. Do not connect other appliances to this circuit.
- ▶ Please report to or take consent by the supply authority before connection to the system.

## ⚠ Warning:

Describes precautions that must be observed to prevent danger of injury or death to the user.

## ⚠ Caution:

Describes precautions that must be observed to prevent damage to the unit.

## ⚠ Warning:

- The unit must not be installed by the user. Ask a dealer or an authorized technician to install the unit. If the unit is installed incorrectly, water leakage, electric shock, or fire may result.
- For installation work, follow the instructions in the Installation Manual and use tools and pipe components specifically made for use with R410A refrigerant. The R410A refrigerant in the HFC system is pressurized 1.6 times the pressure of usual refrigerants. If pipe components not designed for R410A refrigerant are used and the unit is not installed correctly, the pipes may burst and cause damage or injuries. In addition, water leakage, electric shock, or fire may result.
- The unit must be installed according to the instructions in order to minimize the risk of damage from earthquakes, typhoons, or strong winds. An incorrectly installed unit may fall down and cause damage or injuries.
- The unit must be securely installed on a structure that can sustain its weight. If the unit is mounted on an unstable structure, it may fall down and cause damage or injuries.
- If the air conditioner is installed in a small room, measures must be taken to prevent the refrigerant concentration in the room from exceeding the safety limit in the event of refrigerant leakage. Consult a dealer regarding the appropriate measures to prevent the allowable concentration from being exceeded. Should the refrigerant leak and cause the concentration limit to be exceeded, hazards due to lack of oxygen in the room may result.
- Ventilate the room if refrigerant leaks during operation. If refrigerant comes into contact with a flame, poisonous gases will be released.
- All electric work must be performed by a qualified technician according to local regulations and the instructions given in this manual. The units must be powered by dedicated power lines and the correct voltage and circuit breakers must be used. Power lines with insufficient capacity or incorrect electrical work may result in electric shock or fire.
- Use C1220 copper phosphorus, for copper and copper alloy seamless

After installation work has been completed, explain the "Safety Precautions," use, and maintenance of the unit to the customer according to the information in the Operation Manual and perform the test run to ensure normal operation. Both the Installation Manual and Operation Manual must be given to the user for keeping. These manuals must be passed on to subsequent users.

⚡ : Indicates a part which must be grounded.

## ⚠ Warning:

Carefully read the labels affixed to the main unit.

- pipes, to connect the refrigerant pipes. If the pipes are not connected correctly, the unit will not be properly grounded and electric shock may result.
- Use only specified cables for wiring. The wiring connections must be made securely with no tension applied on the terminal connections. Also, never splice the cables for wiring (unless otherwise indicated in this document). Failure to observe these instructions may result in overheating or a fire.
- The terminal block cover panel of the outdoor unit must be firmly attached. If the cover panel is mounted incorrectly and dust and moisture enter the unit, electric shock or fire may result.
- When installing or relocating, or servicing the air conditioner, use only the specified refrigerant (R410A) to charge the refrigerant lines. Do not mix it with any other refrigerant and do not allow air to remain in the lines. If air is mixed with the refrigerant, then it can be the cause of abnormal high pressure in the refrigerant line, and may result in an explosion and other hazards. The use of any refrigerant other than that specified for the system will cause mechanical failure or system malfunction or unit breakdown. In the worst case, this could lead to a serious impediment to securing product safety.
- Use only accessories authorized by Mitsubishi Electric and ask a dealer or an authorized technician to install them. If accessories are incorrectly installed, water leakage, electric shock, or fire may result.
- Do not alter the unit. Consult a dealer for repairs. If alterations or repairs are not performed correctly, water leakage, electric shock, or fire may result.
- The user should never attempt to repair the unit or transfer it to another location. If the unit is installed incorrectly, water leakage, electric shock, or fire may result. If the air conditioner must be repaired or moved, ask a dealer or an authorized technician.
- After installation has been completed, check for refrigerant leaks. If refrigerant leaks into the room and comes into contact with the flame of a heater or portable cooking range, poisonous gases will be released.

### 1.1. Before installation

#### ⚠ Caution:

- Do not use the unit in an unusual environment. If the air conditioner is installed in areas exposed to steam, volatile oil (including machine oil), or sulfuric gas, areas exposed to high salt content such as the seaside, or areas where the unit will be covered by snow, the performance can be significantly reduced and the internal parts can be damaged.
- Do not install the unit where combustible gases may leak, be produced, flow, or accumulate. If combustible gas accumulates around the unit, fire or explosion may result.
- The outdoor unit produces condensation during the heating operation. Make sure to provide drainage around the outdoor unit if such condensation is likely to cause damage.

- When installing the unit in a hospital or communications office, be prepared for noise and electronic interference. Inverters, home appliances, high-frequency medical equipment, and radio communications equipment can cause the air conditioner to malfunction or breakdown. The air conditioner may also affect medical equipment, disturbing medical care, and communications equipment, harming the screen display quality.

### 1.2. Before installation (relocation)

#### ⚠ Caution:

- Be extremely careful when transporting or installing the units. 2 or more persons are needed to handle the unit, as it weighs 20 kg or more. Do not grasp the packaging bands. Wear protective gloves to remove the unit from the packaging and to move it, as you can injure your hands on the fins or the edge of other parts.
- Be sure to safely dispose of the packaging materials. Packaging materials, such as nails and other metal or wooden parts may cause stabs or other injuries.

- The base and attachments of the outdoor unit must be periodically checked for looseness, cracks or other damage. If such defects are left uncorrected, the unit may fall down and cause damage or injuries.
- Do not clean the air conditioner unit with water. Electric shock may result.
- Tighten all flare nuts to specification using a torque wrench. If tightened too much, the flare nut can break after an extended period and refrigerant can leak out.

# 1. Safety precautions

## 1.3. Before electric work

### ⚠ Caution:

- Be sure to install circuit breakers. If not installed, electric shock may result.
- For the power lines, use standard cables of sufficient capacity. Otherwise, a short circuit, overheating, or fire may result.
- When installing the power lines, do not apply tension to the cables. If the connections are loosened, the cables can snap or break and overheating or fire may result.

- Be sure to ground the unit. Do not connect the ground wire to gas or water pipes, lighting rods, or telephone grounding lines. If the unit is not properly grounded, electric shock may result.
- Use circuit breakers (ground fault interrupter, isolating switch (+B fuse), and molded case circuit breaker) with the specified capacity. If the circuit breaker capacity is larger than the specified capacity, breakdown or fire may result.

## 1.4. Before starting the test run

### ⚠ Caution:

- Turn on the main power switch more than 12 hours before starting operation. Starting operation just after turning on the power switch can severely damage the internal parts. Keep the main power switch turned on during the operation season.
- Before starting operation, check that all panels, guards and other protective parts are correctly installed. Rotating, hot, or high voltage parts can cause injuries.
- Do not touch any switch with wet hands. Electric shock may result.

- Do not touch the refrigerant pipes with bare hands during operation. The refrigerant pipes are hot or cold depending on the condition of the flowing refrigerant. If you touch the pipes, burns or frostbite may result.
- After stopping operation, be sure to wait at least five minutes before turning off the main power switch. Otherwise, water leakage or breakdown may result.

### Note:

A low knocking sound might be heard from the Fan Section of this unit during the test run. This is caused by the torque fluctuating to control the Fan revolutions. This is not a defect in the unit.

## 1.5. Using R410A refrigerant air conditioners

### ⚠ Caution:

- Use new refrigerant pipes.  
Note the following if reusing existing pipes that carried R22 refrigerant.
  - Be sure to clean the pipes and make sure that the insides of the pipes are clean.
  - Replace the existing flare nuts and flare the flared sections again.
  - Do not use thin pipes. (Refer to page 5)
- Use C1220 copper phosphorus, for copper and copper alloy seamless pipes, to connect the refrigerant pipes. Make sure the insides of the pipes are clean and do not contain any harmful contaminants such as sulfuric compounds, oxidants, debris, or dust. Use pipes with the specified thickness. (Refer to page 5)
- Store the pipes to be used during installation indoors and keep both ends of the pipes sealed until just before brazing. (Leave elbow joints, etc. in their packaging.) If dust, debris, or moisture enters the refrigerant lines, oil deterioration or compressor breakdown may result.
- Use ester oil, ether oil, alkylbenzene oil (small amount) as the refrigeration oil applied to the flared sections. If mineral oil is mixed in the refrigeration oil, oil deterioration may result.

- Do not use refrigerant other than R410A refrigerant. If another refrigerant is used, the chlorine will cause the oil to deteriorate.
- Use a vacuum pump with a reverse flow check valve.  
If the vacuum pump oil flows backward into the refrigerant lines, refrigerant oil deterioration may result.
- Use the following tools specifically designed for use with R410A refrigerant. The following tools are necessary to use R410A refrigerant. Contact your nearest dealer for any questions.

Tools (for R410A)	
Gauge manifold	Flare tool
Charge hose	Size adjustment gauge
Gas leak detector	Vacuum pump adapter
Torque wrench	Electronic refrigerant charging scale

- Be sure to use the correct tools. If dust, debris, or moisture enters the refrigerant lines, refrigeration oil deterioration may result.
- Do not use a charging cylinder. If a charging cylinder is used, the composition of the refrigerant will change and the efficiency will be lowered.

# 2. Installation location

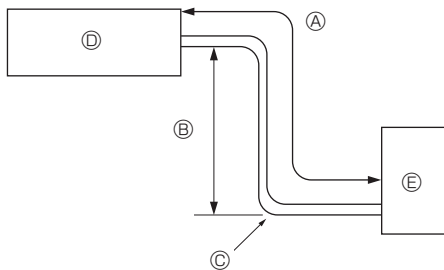

Fig. 2-1

## 2.1. Refrigerant pipe (Fig. 2-1)

- ▶ Check that the difference between the heights of the indoor and outdoor units, the length of refrigerant pipe, and the number of bends in the pipe are within the limits shown below.

Models	Ⓐ Pipe length (one way)	Ⓑ Height difference	Ⓒ Number of bends (one way)
P71,100,125,140	Max. 50 m	Max. 30 m	Max. 15

- Height difference limitations are binding regardless of which unit, indoor or outdoor, is positioned higher.
- Ⓓ Indoor unit
- Ⓔ Outdoor unit

## 2.2. Choosing the outdoor unit installation location

- Avoid locations exposed to direct sunlight or other sources of heat.
- Select a location from which noise emitted by the unit will not inconvenience neighbors.
- Select a location permitting easy wiring and pipe access to the power source and indoor unit.
- Avoid locations where combustible gases may leak, be produced, flow, or accumulate.
- Note that water may drain from the unit during operation.
- Select a level location that can bear the weight and vibration of the unit.
- Avoid locations where the unit can be covered by snow. In areas where heavy snow fall is anticipated, special precautions such as raising the installation location or installing a hood on the air intake must be taken to prevent the snow from blocking the air intake or blowing directly against it. This can reduce the airflow and a malfunction may result.
- Avoid locations exposed to oil, steam, or sulfuric gas.
- Use the transportation handles of the outdoor unit to transport the unit. If the unit is carried from the bottom, hands or fingers may be pinched.

### ■ P71-P140

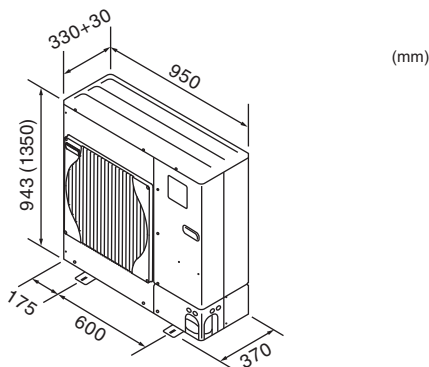

Fig. 2-2

## 2.3. Outline dimensions (Outdoor unit) (Fig. 2-2)

The figure in parenthesis is for P125, P140 models.

## 2. Installation location

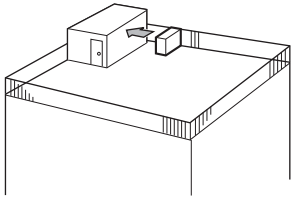

Fig. 2-3

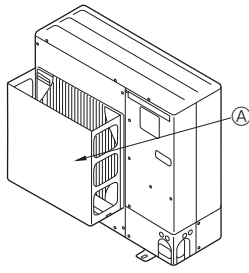

Fig. 2-4

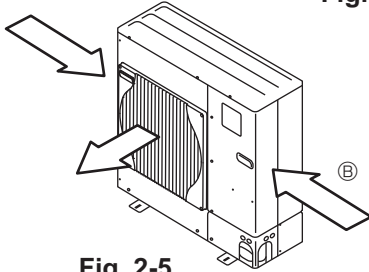

Fig. 2-5

### 2.4. Ventilation and service space

#### 2.4.1. Windy location installation

When installing the outdoor unit on a rooftop or other location unprotected from the wind, situate the air outlet of the unit so that it is not directly exposed to strong winds. Strong wind entering the air outlet may impede the normal airflow and a malfunction may result.

The following shows three examples of precautions against strong winds.

- ① Face the air outlet towards the nearest available wall about 50 cm away from the wall. (Fig. 2-3)
- ② Install an optional air guide if the unit is installed in a location where strong winds from a typhoon, etc. may directly enter the air outlet. (Fig. 2-4)
  - Ⓐ Air outlet guide
- ③ Position the unit so that the air outlet blows perpendicularly to the seasonal wind direction, if possible. (Fig. 2-5)
  - Ⓑ Wind direction

#### 2.4.2. When installing a single outdoor unit (Refer to the last page)

Minimum dimensions are as follows, except for Max., meaning Maximum dimensions, indicated.

The figures in parentheses are for P125, P140 models.

Refer to the figures for each case.

- ① Obstacles at rear only (Fig. 2-6)
- ② Obstacles at rear and above only (Fig. 2-7)
- ③ Obstacles at rear and sides only (Fig. 2-8)
- ④ Obstacles at front only (Fig. 2-9)
  - \* When using an optional air outlet guide, the clearance for P125, P140 models is 500 mm or more.
- ⑤ Obstacles at front and rear only (Fig. 2-10)
  - \* When using an optional air outlet guide, the clearance for P125, P140 models is 500 mm or more.
- ⑥ Obstacles at rear, sides, and above only (Fig. 2-11)
  - Do not install the optional air outlet guides for upward airflow.

#### 2.4.3. When installing multiple outdoor units (Refer to the last page)

Leave 10 mm for P71-140 space or more between the units.

- ① Obstacles at rear only (Fig. 2-12)
- ② Obstacles at rear and above only (Fig. 2-13)
  - No more than three units must be installed side by side. In addition, leave space as shown.
  - Do not install the optional air outlet guides for upward airflow.
- ③ Obstacles at front only (Fig. 2-14)
  - \* When using an optional air outlet guide, the clearance for P125, P140 models is 1000 mm or more.
- ④ Obstacles at front and rear only (Fig. 2-15)
  - \* When using an optional air outlet guide, the clearance for P125, P140 models is 1000 mm or more.
- ⑤ Single parallel unit arrangement (Fig. 2-16)
  - \* When using an optional air outlet guide installed for upward airflow, the clearance is 500 (1000) mm or more.
- ⑥ Multiple parallel unit arrangement (Fig. 2-17)
  - \* When using an optional air outlet guide installed for upward airflow, the clearance is 1000 (1500) mm or more.
- ⑦ Stacked unit arrangement (Fig. 2-18)
  - The units can be stacked up to two units high.
  - No more than 2 stacked units must be installed side by side. In addition, leave space as shown.

## 3. Installing the outdoor unit

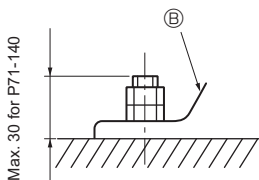
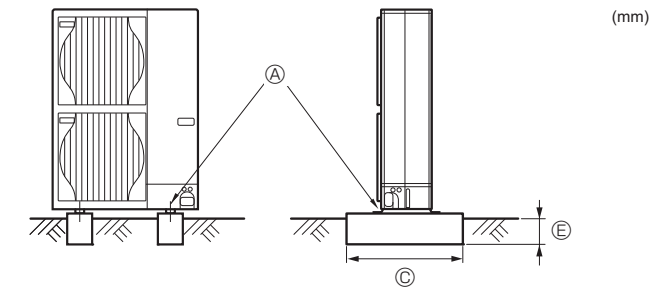

- Ⓐ M10 (3/8") bolt
- Ⓑ Base
- Ⓒ As long as possible.
- Ⓓ Vent
- Ⓔ Set deep in the ground.

#### ■ P71-140

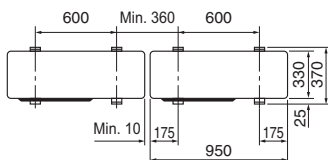

Fig. 3-1

- Be sure to install the unit in a sturdy, level surface to prevent rattling noises during operation. (Fig. 3-1)

<Foundation specifications>

Foundation bolt	M10 (3/8")
Thickness of concrete	120 mm
Length of bolt	70 mm
Weight-bearing capacity	320 kg

- Make sure that the length of the foundation bolt is within 30 mm of the bottom surface of the base.
- Secure the base of the unit firmly with four-M10 foundation bolts in sturdy locations.

#### Installing the outdoor unit

- Do not block the vent. If the vent is blocked, operation will be hindered and breakdown may result.
- In addition to the unit base, use the installation holes on the back of the unit to attach wires, etc., if necessary to install the unit. Use self-tapping screws (ø5 × 15 mm or less) and install on site.

#### ⚠ Warning:

- **The unit must be securely installed on a structure that can sustain its weight. If the unit is mounted on an unstable structure, it may fall down and cause damage or injuries.**
- **The unit must be installed according to the instructions in order to minimize the risk of damage from earthquakes, typhoons, or strong winds. An incorrectly installed unit may fall down and cause damage or injuries.**

## 4. Installing the refrigerant piping

### 4.1. Precautions for devices that use R410A refrigerant

- Refer to page 3 for precautions not included below on using air conditioners with R410A refrigerant.
- Use ester oil, ether oil, alkylbenzene oil (small amount) as the refrigeration oil applied to the flared sections.
- Use C1220 copper phosphorus, for copper and copper alloy seamless pipes, to connect the refrigerant pipes. Use refrigerant pipes with the thicknesses specified in the table to the below. Make sure the insides of the pipes are clean and do not contain any harmful contaminants such as sulfuric compounds, oxidants, debris, or dust.

#### ⚠ Warning:

When installing or relocating, or servicing the air conditioner, use only the specified refrigerant (R410A) to charge the refrigerant lines. Do not mix it with any other refrigerant and do not allow air to remain in the lines.

If air is mixed with the refrigerant, then it can be the cause of abnormal high pressure in the refrigerant line, and may result in an explosion and other hazards.

The use of any refrigerant other than that specified for the system will cause mechanical failure or system malfunction or unit breakdown. In the worst case, this could lead to a serious impediment to securing product safety.

P71-140	
Liquid pipe	ø9.52 thickness 0.8 mm
Gas pipe	ø15.88 thickness 1.0 mm

- Do not use pipes thinner than those specified above.

### 4.2. Connecting pipes (Fig. 4-1)

- When commercially available copper pipes are used, wrap liquid and gas pipes with commercially available insulation materials (heat-resistant to 100 °C or more, thickness of 12 mm or more).
- Be sure to separate thermal insulation for gas and liquid refrigerant pipes.
- The indoor parts of the drain pipe should be wrapped with polyethylene foam insulation materials (specific gravity of 0.03, thickness of 9 mm or more).
- Apply thin layer of refrigerant oil to pipe and joint seating surface before tightening flare nut. ①
- Use 2 wrenches to tighten piping connections. ②
- Use leak detector or soapy water to check for gas leaks after connections are completed.
- Apply refrigerating machine oil over the entire flare seat surface. ③
- Use the flare nuts for the following pipe size. ④

P71-140	
Gas side	Pipe size (mm) ø15.88
Liquid side	Pipe size (mm) ø9.52

- When bending the pipes, be careful not to break them. Bend radius of 100 mm to 150 mm are sufficient.
- Make sure the pipes do not contact the compressor. Abnormal noise or vibration may result.

① Pipes must be connected starting from the indoor unit.

Flare nuts must be tightened with a torque wrench.

② Flare the liquid pipes and gas pipes and apply a thin layer of refrigeration oil (Applied on site).

• When usual pipe sealing is used, refer to Table 1 for flaring of R410A refrigerant pipes.

The size adjustment gauge can be used to confirm A measurements.

#### ⚠ Warning:

When installing the unit, securely connect the refrigerant pipes before starting the compressor.

Table 1 (Fig. 4-2)

Copper pipe O.D. (mm)	A (mm)	
	Flare tool for R410A	Flare tool for R22-R407C
	Clutch type	
ø6.35 (1/4")	0 - 0.5	1.0 - 1.5
ø9.52 (3/8")	0 - 0.5	1.0 - 1.5
ø12.7 (1/2")	0 - 0.5	1.0 - 1.5
ø15.88 (5/8")	0 - 0.5	1.0 - 1.5
ø19.05 (3/4")	0 - 0.5	1.0 - 1.5

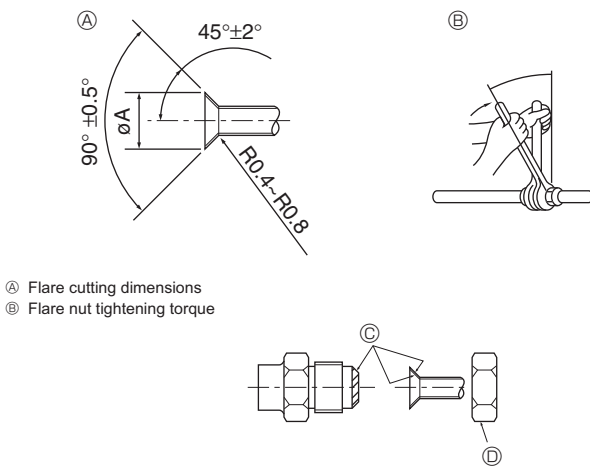

Fig. 4-1

① (Fig. 4-1)

Copper pipe O.D. (mm)	Flare dimensions øA dimensions (mm)
ø6.35	8.7 - 9.1
ø9.52	12.8 - 13.2
ø12.7	16.2 - 16.6
ø15.88	19.3 - 19.7
ø19.05	23.6 - 24.0

② (Fig. 4-1)

Copper pipe O.D. (mm)	Flare nut O.D. (mm)	Tightening torque (N·m)
ø6.35	17	14 - 18
ø6.35	22	34 - 42
ø9.52	22	34 - 42
ø12.7	26	49 - 61
ø12.7	29	68 - 82
ø15.88	29	68 - 82
ø15.88	36	100 - 120
ø19.05	36	100 - 120

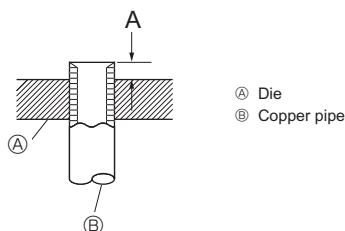

Fig. 4-2

## 4. Installing the refrigerant piping

■ P71-140

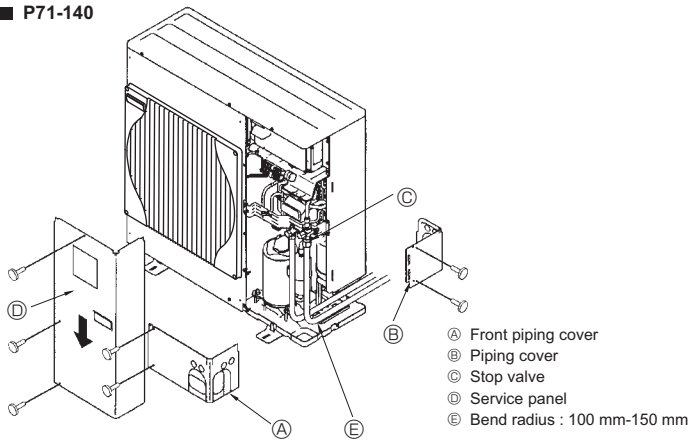
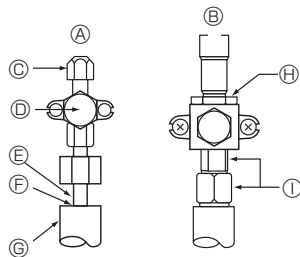

Fig. 4-3



- Ⓐ Stop valve <Liquid side>
- Ⓑ Stop valve <Gas side>
- Ⓒ Service port
- Ⓓ Open/Close section
- Ⓔ Local pipe
- Ⓕ Sealed, same way for gas side
- Ⓖ Pipe cover
- Ⓗ Do not use a wrench here. Refrigerant leakage may result.
- Ⓘ Use 2 wrenches here.

Fig. 4-4

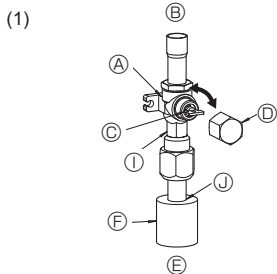

Fig. 4-5

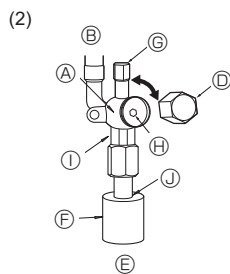
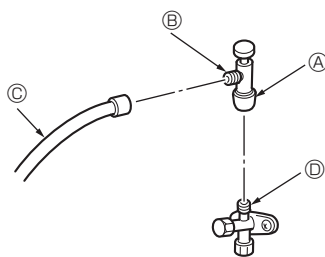

Fig. 4-6

- Ⓐ Valve
- Ⓑ Unit side
- Ⓒ Handle
- Ⓓ Cap
- Ⓔ Local pipe side
- Ⓕ Pipe cover
- Ⓖ Service port
- Ⓗ Wrench hole
- Ⓘ Double spanner section (Do not apply a spanner other than to this section. Doing so would cause coolant leaks.)
- Ⓙ Seal section (Seal the end of the heat insulation material at the pipe connection section with whatever seal material you have on hand so that water does not infiltrate the heat insulation material.)



- \* The figure to the left is an example only. The stop valve shape, service port position, etc., may vary according to the model.
- \* Turn section Ⓐ only. (Do not further tighten sections Ⓐ and Ⓑ together.)

- Ⓒ Charge hose
- Ⓑ Service port

Fig. 4-7

### 4.3. Refrigerant piping (Fig. 4-3)

■ For P71-140

Remove the service panel Ⓓ (3 screws) and the front piping cover Ⓐ (2 screws) and rear piping cover Ⓑ (2 screws).

- ① Perform refrigerant piping connections for the indoor/outdoor unit when the outdoor unit's stop valve is completely closed.
- ② Vacuum-purge air from the indoor unit and the connection piping.
- ③ After connecting the refrigerant pipes, check the connected pipes and the indoor unit for gas leaks. (Refer to 4.4 Refrigerant pipe airtight testing method)
- ④ A high-performance vacuum pump is used at the stop valve service port to maintain a vacuum for an adequate time (at least 1 hour after reaching  $-101$  kPa (5 Torr)) in order to vacuum dry the inside of the pipes. Always check the degree of vacuum at the gauge manifold. If there is any moisture left in the pipe, the degree of vacuum is sometimes not reached with short-time vacuum application. After vacuum drying, completely open the stop valves (both liquid and gas) for the outdoor unit. This completely links the indoor and outdoor refrigerant circuits.
  - If the vacuum drying is inadequate, air and water vapor remain in the refrigerant circuits and can cause abnormal rise of high pressure, abnormal drop of low pressure, deterioration of the refrigerant machine oil due to moisture, etc.
  - If the stop valves are left closed and the unit is operated, the compressor and control valves will be damaged.
  - Use a leak detector or soapy water to check for gas leaks at the pipe connection sections of the outdoor unit.
  - Do not use the refrigerant from the unit to purge air from the refrigerant lines.
  - After the valve work is completed, tighten the valve caps to the correct torque: 20 to 25 N·m (200 to 250 kgf·cm). Failure to replace and tighten the caps may result in refrigerant leakage. In addition, do not damage the insides of the valve caps as they act as a seal to prevent refrigerant leakage.
- ⑤ Use sealant to seal the ends of the thermal insulation around the pipe connection sections to prevent water from entering the thermal insulation.

### 4.4. Refrigerant pipe airtight testing method

- (1) Connect the testing tools.
  - Make sure the stop valves Ⓐ Ⓑ are closed and do not open them.
  - Add pressure to the refrigerant lines through the service port Ⓒ of the liquid stop valve Ⓓ.
- (2) Do not add pressure to the specified pressure all at once; add pressure little by little.
  - ① Pressurize to 0.5 MPa (5 kgf/cm<sup>2</sup>G), wait 5 minutes, and make sure the pressure does not decrease.
  - ② Pressurize to 1.5 MPa (15 kgf/cm<sup>2</sup>G), wait 5 minutes, and make sure the pressure does not decrease.
  - ③ Pressurize to 4.15 MPa (41.5 kgf/cm<sup>2</sup>G) and measure the surrounding temperature and refrigerant pressure.
- (3) If the specified pressure holds for about one day and does not decrease, the pipes have passed the test and there are no leaks.
  - If the surrounding temperature changes by 1 °C, the pressure will change by about 0.03 MPa (0.3 kgf/cm<sup>2</sup>G). Make the necessary corrections.
- (4) If the pressure decreases in steps (2) or (3), there is a gas leak. Look for the source of the gas leak.

### 4.5. Stop valve opening method

The stop valve opening method varies according to the outdoor unit model. Use the appropriate method to open the stop valves.

(1) Gas side of P71-140 (Fig. 4-5)

- ① Remove the cap, pull the handle toward you and rotate 1/4 turn in a counterclockwise direction to open.
  - ② Make sure that the stop valve is open completely, push in the handle and rotate the cap back to its original position.
- (2) Liquid side of P71-140 (Fig. 4-6)
- ① Remove the cap and turn the valve rod counterclockwise as far as it will go with the use of a 4 mm hexagonal wrench. Stop turning when it hits the stopper. (ø9.52: Approximately 10 revolutions)
  - ② Make sure that the stop valve is open completely and rotate the cap back to its original position.

Refrigerant pipes are protectively wrapped for P71-140

- The pipes can be protectively wrapped up to a diameter of ø90 before or after connecting the pipes. Cut out the knockout in the pipe cover following the groove and wrap the pipes.

Pipe inlet gap for P71-140

- Use putty or sealant to seal the pipe inlet around the pipes so that no gaps remain. (If the gaps are not closed, noise may be emitted or water and dust will enter the unit and breakdown may result.)

### Precautions when using the charge valve (Fig.4-7)

Do not tighten the service port too much when installing it, otherwise, the valve core could be deformed and become loose, causing a gas leak.

After positioning section Ⓑ in the desired direction, turn section Ⓐ only and tighten it.

Do not further tighten sections Ⓐ and Ⓑ together after tightening section Ⓐ.

## 4. Installing the refrigerant piping

### 4.6. Addition of refrigerant

- Additional charging is not necessary if the pipe length does not exceed 30 m.
  - If the pipe length is exceeds 30 m, charge the unit with additional R410A refrigerant according to the permitted pipe lengths in the following table.
  - \* When the unit is stopped, charge the unit with the additional refrigerant through the liquid stop valve after the pipe extensions and indoor unit have been vacuumized.
- When the unit is operating, add refrigerant to the gas check valve using a safety charger. Do not add liquid refrigerant directly to the check valve.

- \* After charging the unit with refrigerant, note the added refrigerant amount on the service label (attached to the unit). Refer to the "1.5. Using R410A refrigerant air conditioners" for more information.
- Be careful when installing multiple units. Connecting to an incorrect indoor unit can lead to abnormally high pressure and have a serious effect on operation performance.

Model	Permitted pipe length	Permitted vertical difference	Additional refrigerant charging amount	
			31 - 40 m	41 - 50 m
P71-140	-50 m	-30 m	0.6 kg	1.2 kg

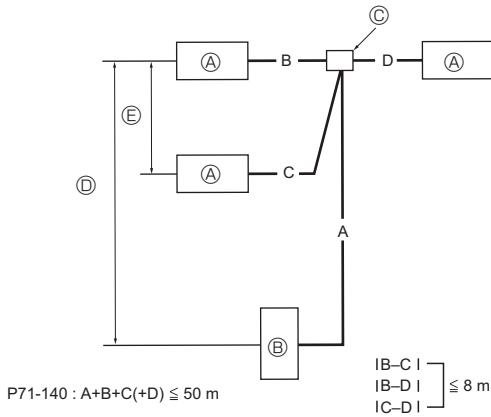

Fig. 4-8

### 4.7. For twin/triple combination

Refrigerant piping limitation of length, height difference are shown in the figure. (Fig. 4-8)

- Ⓐ Indoor unit
- Ⓑ Outdoor unit
- Ⓒ Multi distribution pipe (option)
- Ⓓ Height difference (Indoor unit-Outdoor unit) Max. 30 m
- Ⓔ Height difference (Indoor unit-Indoor unit) Max. 1 m

## 5. Drainage piping work

### Outdoor unit drainage pipe connection

When drain piping is necessary, use the drain socket or the drain pan (option).

	P71-140
Drain socket	PAC-SG61DS-E
Drain pan	PAC-SG64DP-E

## 6. Electrical work

### 6.1. Outdoor unit (Fig. 6-1, Fig. 6-2)

- ① Remove the service panel.
- ② Wire the cables referring to the Fig. 6-1 and the Fig. 6-2.

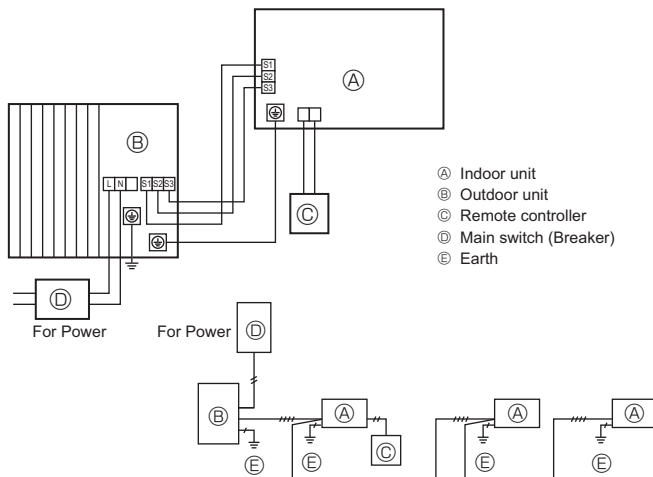
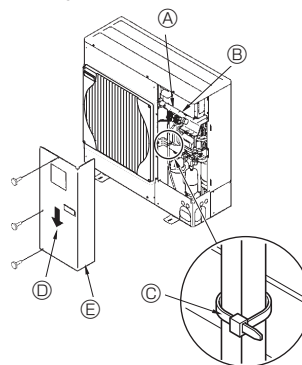
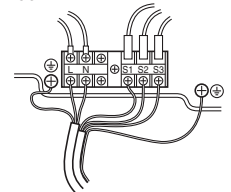

Fig. 6-1

### ■ P71-140



### ■ P71-100V



### ■ P71-140Y

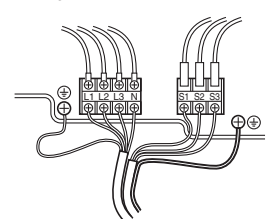

Fig. 6-2

- Ⓐ Earth terminal
- Ⓑ Terminal block
- Ⓒ Clamp
- Ⓓ Service panel
- Ⓔ Wire the cables so that they do not contact the center of the service panel or the gas valve.

**⚠ Caution:**  
Be sure to install N-Line. Without N-Line, it could cause damage to unit.

## 6. Electrical work

### 6.2. Field electrical wiring

Outdoor unit model		P71V	P100V	P71Y	P100Y	P125Y	P140Y
Outdoor unit power supply		~N (single), 50 Hz, 230 V		3N~ (3 phase), 50 Hz, 400 V			
Outdoor unit input capacity Main switch (Breaker)		*1	32 A	16 A		25 A	
Max. Permissible System Impedance (Ω)			0.06	0.23	0.22	0.14	0.12
Wiring Wire No. x size (mm <sup>2</sup> )	Outdoor unit power supply		2 × Min. 4	4 × Min. 1.5		4 × Min. 2.5	
	Outdoor unit power supply earth		1 × Min. 4	1 × Min. 1.5		1 × Min. 2.5	
	Indoor unit-Outdoor unit	*2		3 × 1.5 (Polar)			
Circuit rating	Indoor unit-Outdoor unit earth			1 × Min. 1.5			
	Remote controller-Indoor unit	*3		2 × 0.3 (Non-polar)			
	Outdoor unit L-N	*4		AC 230 V			
	Outdoor unit L1-N, L2-N, L3-N			AC 230 V			
	Indoor unit-Outdoor unit S1-S2	*4		AC 230 V			
	Indoor unit-Outdoor unit S2-S3	*4		DC 24 V			
	Remote controller-Indoor unit	*4		DC 12 V			

\*1. A breaker with at least 3.0 mm contact separation in each poles shall be provided. Use earth leakage breaker (NV).

\*2. Max. 45 m

If 2.5 mm<sup>2</sup> used, Max. 50 m

If 2.5 mm<sup>2</sup> used and S3 separated, Max. 80 m

\*3. The 10 m wire is attached in the remote controller accessory.

\*4. The figures are NOT always against the ground.

S3 terminal has DC 24 V against S2 terminal. However between S3 and S1, these terminals are NOT electrically insulated by the transformer or other device.

**Notes:** 1. Wiring size must comply with the applicable local and national code.

2. Power supply cords and Indoor/Outdoor unit connecting cords shall not be lighter than polychloroprene sheathed flexible cord. (Design 60245 IEC 57)

3. Install an earth longer than other cables.

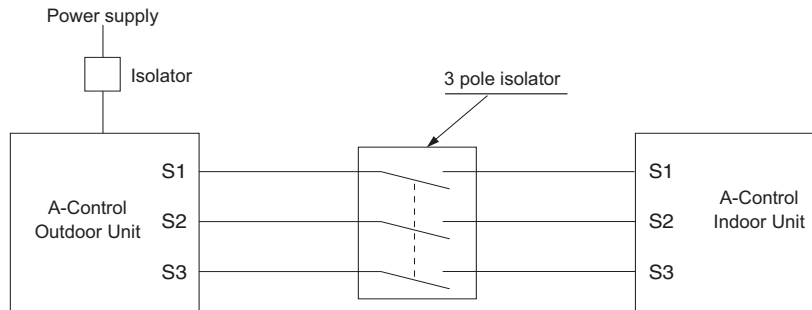

#### ⚠ Warning:

In case of A-control wiring, there is high voltage potential on the S3 terminal caused by electrical circuit design that has no electrical insulation between power line and communication signal line. Therefore, please turn off the main power supply when servicing. And do not touch the S1, S2, S3 terminals when the power is energized. If isolator should be used between indoor unit and outdoor unit, please use 3-pole type.

Never splice the power cable or the indoor-outdoor connection cable, otherwise it may result in a smoke, a fire or communication failure.

## 7. Test run

### 7.1. Before test run

▶ After completing installation and the wiring and piping of the indoor and outdoor units, check for refrigerant leakage, looseness in the power supply or control wiring, wrong polarity, and no disconnection of one phase in the supply.

▶ Use a 500-volt megohmmeter to check that the resistance between the power supply terminals and ground is at least 1.0MΩ.

▶ Do not carry out this test on the control wiring (low voltage circuit) terminals.

#### ⚠ Warning:

Do not use the air conditioner if the insulation resistance is less than 1.0MΩ.

#### Insulation resistance

After installation or after the power source to the unit has been cut for an extended period, the insulation resistance will drop below 1 MΩ due to refrigerant accumulating in the compressor. This is not a malfunction. Perform the following procedures.

1. Remove the wires from the compressor and measure the insulation resistance of the compressor.

2. If the insulation resistance is below 1 MΩ, the compressor is faulty or the resistance dropped due the accumulation of refrigerant in the compressor.

3. After connecting the wires to the compressor, the compressor will start to warm up after power is supplied. After supplying power for the times indicated below, measure the insulation resistance again.

- The insulation resistance drops due to accumulation of refrigerant in the compressor. The resistance will rise above 1 MΩ after the compressor is warmed up for 4 hours.

(The time necessary to warm up the compressor varies according to atmospheric conditions and refrigerant accumulation.)

- To operate the compressor with refrigerant accumulated in the compressor, the compressor must be warmed up at least 12 hours to prevent breakdown.

4. If the insulation resistance rises above 1 MΩ, the compressor is not faulty.

#### ⚠ Caution:

- The compressor will not operate unless the power supply phase connection is correct.

- Turn on the power at least 12 hours before starting operation.

- Starting operation immediately after turning on the main power switch can result in severe damage to internal parts. Keep the power switch turned on during the operational season.

▶ The followings must be checked as well.

- The outdoor unit is not faulty. LED1 and LED2 on the control board of the outdoor unit flash when the outdoor unit is faulty.

- Both the gas and liquid stop valves are completely open.

- A protective sheet covers the surface of the DIP switch panel on the control board of the outdoor unit. Remove the protective sheet to operate the DIP switches easily.

- Make sure that the all of the SW5 DIP switches for function changes on the control board of the outdoor unit are set to OFF. If all of the SW5 switches are not set to OFF, record the settings and then set all of the switches to OFF. Begin recovering the refrigerant. After moving the unit to a new location and completing the test run, set the SW5 switches to the previously recorded settings.

#### Note:

A low knocking sound might be heard from the Fan Section of this unit during the test run. This is caused by the torque fluctuating to control the Fan revolutions. This is not a defect in the unit.



## 7. Test run

### 7.2. Test run

#### 7.2.1. Using SW4 in outdoor unit

##### 1) PUH Type

SW4-1	ON	Cooling operation
SW4-2	OFF	
SW4-1	ON	Heating operation
SW4-2	ON	

##### 2) PU Type

SW4-1	ON	Cooling operation
SW4-2	OFF	

\* After performing the test run, set SW4-1 to OFF.

- After power is supplied, a small clicking noise may be heard from the inside of the outdoor unit. The electronic expansion valve is opening and closing. The unit is not faulty.
- A few seconds after the compressor starts, a clanging noise may be heard from the inside of the outdoor unit. The noise is coming from the check valve due to the small difference in pressure in the pipes. The unit is not faulty.
- A low knocking sound might be heard from the Fan Section of this unit during the test run.  
This is caused by the torque fluctuating to control the Fan revolutions. This is not a defect in the unit.

**The test run operation mode cannot be changed by DIP switch SW4-2 during the test run. (To change the test run operation mode during the test run, stop the test run by DIP switch SW4-1. After changing the test run operation mode, resume the test run by switch SW4-1.)**

#### 7.2.2. Using remote controller

Refer to the indoor unit installation manual.

## 8. Special Functions

### Refrigerant collecting (pump down)

Perform the following procedures to collect the refrigerant when moving the indoor unit or the outdoor unit.

#### ① Supply power (circuit breaker).

- \* When power is supplied, make sure that "CENTRALLY CONTROLLED" is not displayed on the remote controller. If "CENTRALLY CONTROLLED" is displayed, the refrigerant collecting (pump down) cannot be completed normally.
- \* Start-up of the indoor-outdoor communication takes about 3 minutes after the power (circuit breaker) is turned on. Start the pump-down operation 3 to 4 minutes after the power (circuit breaker) is turned ON.

#### ② After the liquid stop valve is closed, set SW1-1 on the control board of the outdoor unit to ON. The compressor (outdoor unit) and ventilators (indoor and outdoor units) start operating and refrigerant collecting operation begins. LED1 and LED2 on the control board of the outdoor unit are lit.

- \* Only set SW1-1 to ON if the unit is stopped. However, even if the unit is stopped and SW1-1 is set to ON less than three minutes after the compressor stops, the refrigerant collecting operation cannot be performed. Wait until compressor has been stopped for three minutes and then set SW1-1 to ON again.

#### ③ Because the unit automatically stops in about two to three minutes when the refrigerant collecting operation is completed (LED1 off, LED2 lit), be sure to quickly close the gas stop valve. If LED1 is lit and LED2 is off and the outdoor unit is stopped, refrigerant collection is not properly performed. Open the liquid stop valve completely, and then repeat step ② after three minutes have passed.

- \* If the refrigerant collecting operation has been completed normally (LED1 off, LED2 lit), the unit will remain stopped until the power supply is turned off.

#### ④ Turn off the power supply (circuit breaker).

- \* Note that when the extension piping is very long with large refrigerant amount, it may not be possible to perform a pump-down operation.

#### ⚠ Warning:

**When pumping down the refrigerant, stop the compressor before disconnecting the refrigerant pipes. The compressor may burst if air etc. get into it.**

## 9. System control (Fig. 9-1)

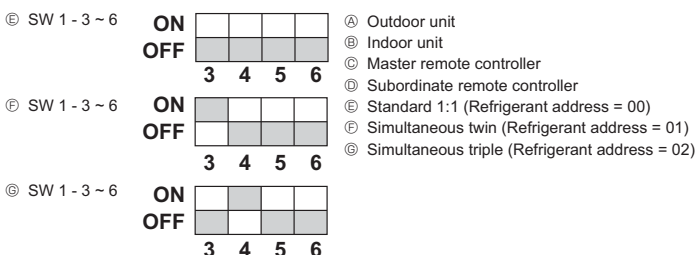

Fig. 9-1

\* Set the refrigerant address using the DIP switch of the outdoor unit.

#### ① Wiring from the Remote Control

This wire is connected to TB5 (terminal board for remote controller) of the indoor unit (non-polar).

#### ② When a Different Refrigerant System Grouping is Used.

Up to 16 refrigerant systems can be controlled as one group using the slim MA remote controller.

#### Note:

**In single refrigerant system (twin/triple), there is no need of wiring ②.**

SW1  
Function table

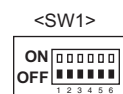

Function	Operation according to switch setting	
	ON	OFF
1 Compulsory defrosting	Start	Normal
2 Error history clear	Clear	Normal
3 Refrigerant system address setting	Settings for outdoor unit addresses 0 to 15	
4		
5		
6		



UNIT: mm  
 ( ): P125, P140

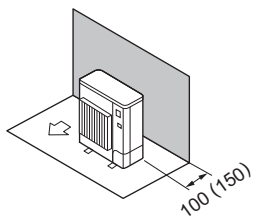

Fig. 2-6

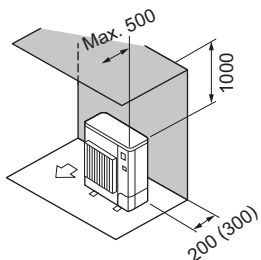

Fig. 2-7

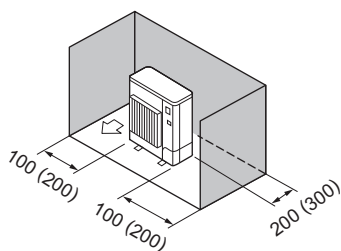

Fig. 2-8

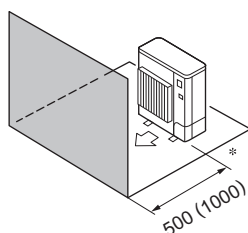

Fig. 2-9

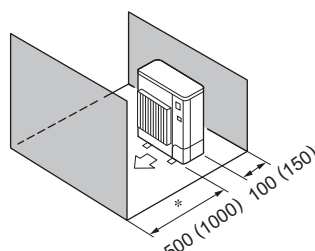

Fig. 2-10

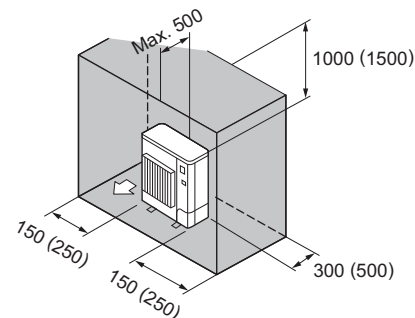

Fig. 2-11

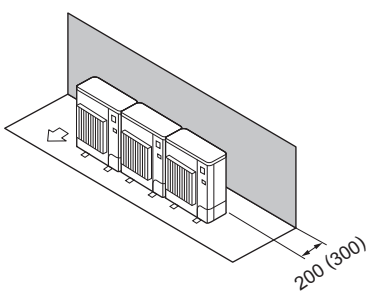

Fig. 2-12

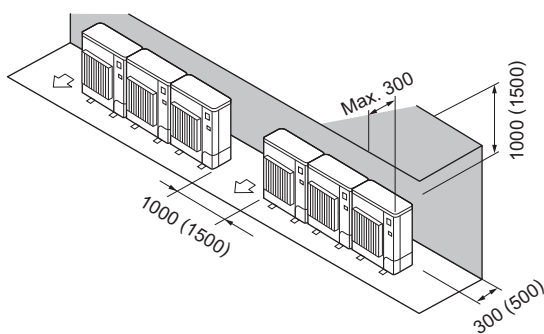

Fig. 2-13

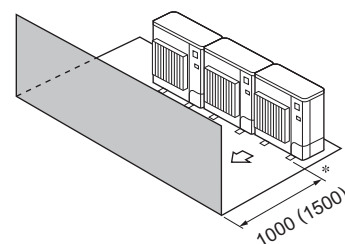

Fig. 2-14

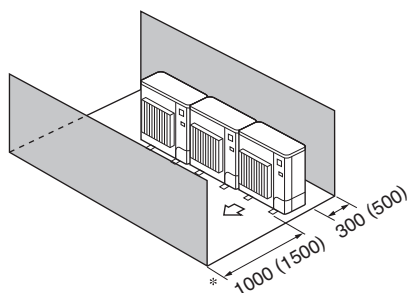

Fig. 2-15

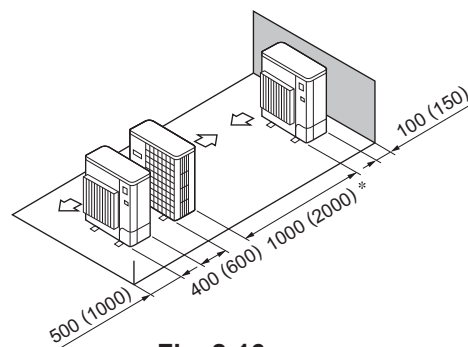

Fig. 2-16

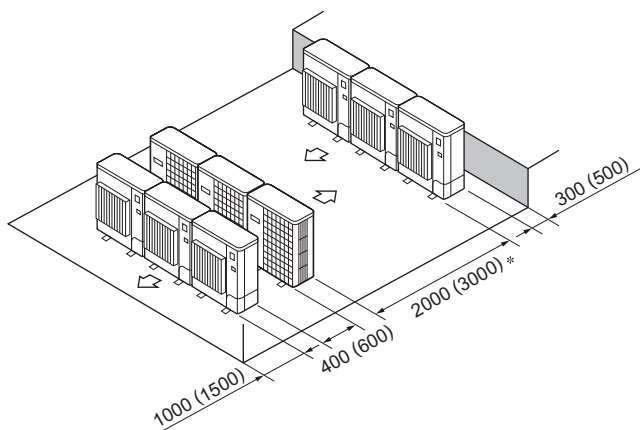

Fig. 2-17

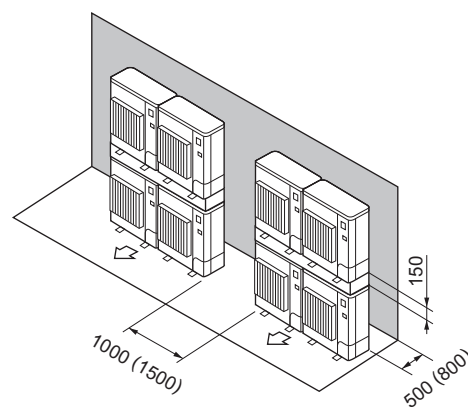

Fig. 2-18

This product is designed and intended for use in the residential,  
commercial and light-industrial environment.

The product at hand is  
based on the following  
EU regulations:

- Low Voltage Directive 2006/95/EC
- Electromagnetic Compatibility Directive  
2004/108/EC

Please be sure to put the contact address/telephone number on  
this manual before handing it to the customer.



**MITSUBISHI ELECTRIC CORPORATION**

HEAD OFFICE: TOKYO BLDG., 2-7-3, MARUNOUCHI, CHIYODA-KU, TOKYO 100-8310, JAPAN