

Air to Water (ATW) Heat pump, Interface (I/F) and Flow temp. controller (FTC) Technical manual

CONTENTS

1. What is ATW heat pump?.....	2
2. Heat pump unit_General information	4
3. System design	15
4. Interface (I/F).....	23
5. Flow temp. controller (FTC).....	55
6. Requirements.....	90
7. System example	91

1

What is ATW heat pump?

1-1. Compare with conventional fossil fuel boiler

- Heat pumps produce water at 30°C – 60°C
- Ideal for underfloor heating
- Average underfloor heating circuit 35°C
- Fossil fuel boilers heat water to 80°C
- Flow temp in rads design temp approx 70°C
- Heat pumps can still be used with radiators
- Larger surface area to emit heat from lower temp water

1-2. Points to notice

1-2-1. Design (Radiator sizing)

- Careful consideration must be given to appropriate application of this technology to maximise its benefits – it will not suit all properties, especially many retrofits
- Heat emitters may need to be larger
- Lower flow temperatures maximise COP
- Various regulations apply to the design and installation of such systems
- Because the flow temp. of heat pump is low compare to fossile fuel boiler, the temperature difference between the primary (flow water) and secondary (room air) becomes little, it makes the heat emission little.
To emit the same amount of heat energy, it is needed to select the radiator that has a larger surface area.
Be especially careful of the surface area when you design the radiator.

1-2-2. Defrost

Note: Occasionally, vapor that is made by the defrost operation may seem as if smoke come up from the outdoor unit.

1-2-3. Water Pressure loss (for packaged type outdoor unit)

- Water pressure lose of the heat exchangers are as follows.
Be aware of the influence when you design total pipng system.

Hex for PUHZ-W50VHA (ACH30-30Plates)

	Secondary (Water - side)					
Flow rate (L/min)	5	10	15	20	25	30
Pressure Loss (kPa)	1.7	6.0	12.4	20.9	31.4	43.8

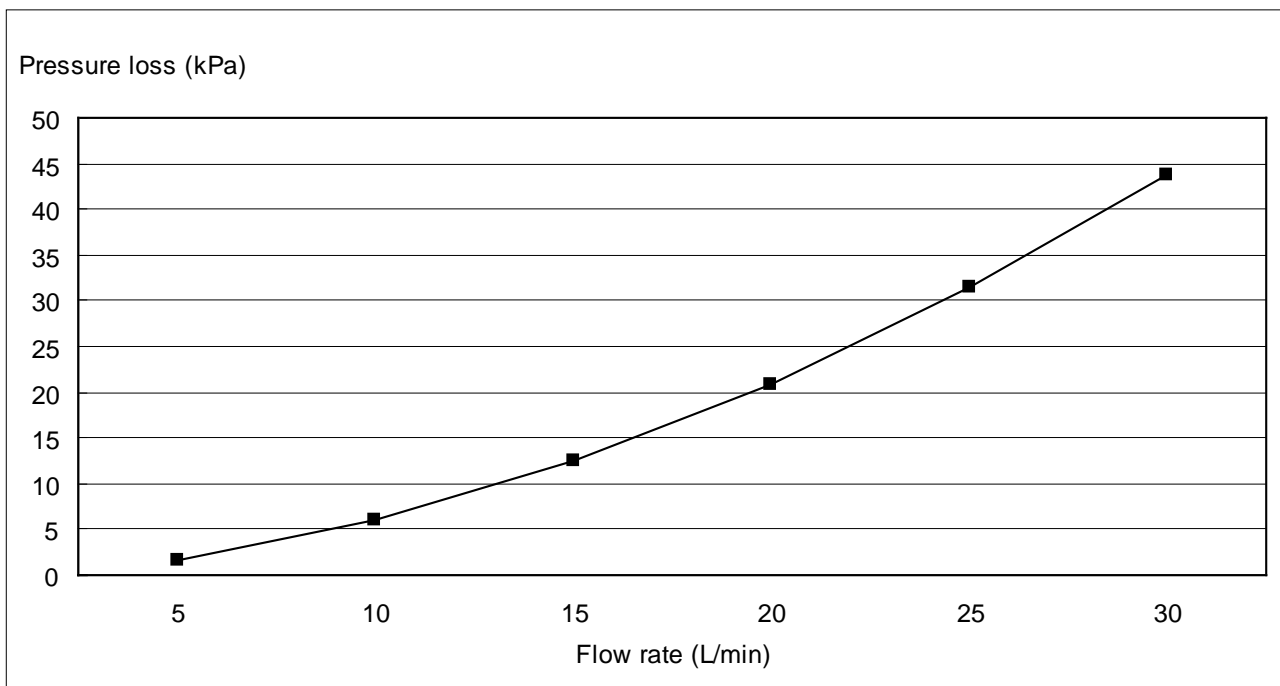



Hex for PUHZ-W85VHA (ACH30-40Plates)

Secondary (Water - side)						
Flow rate (L/min)	5	10	15	20	25	30
Pressure Loss (kPa)	1.0	3.6	7.5	12.5	18.8	26.2

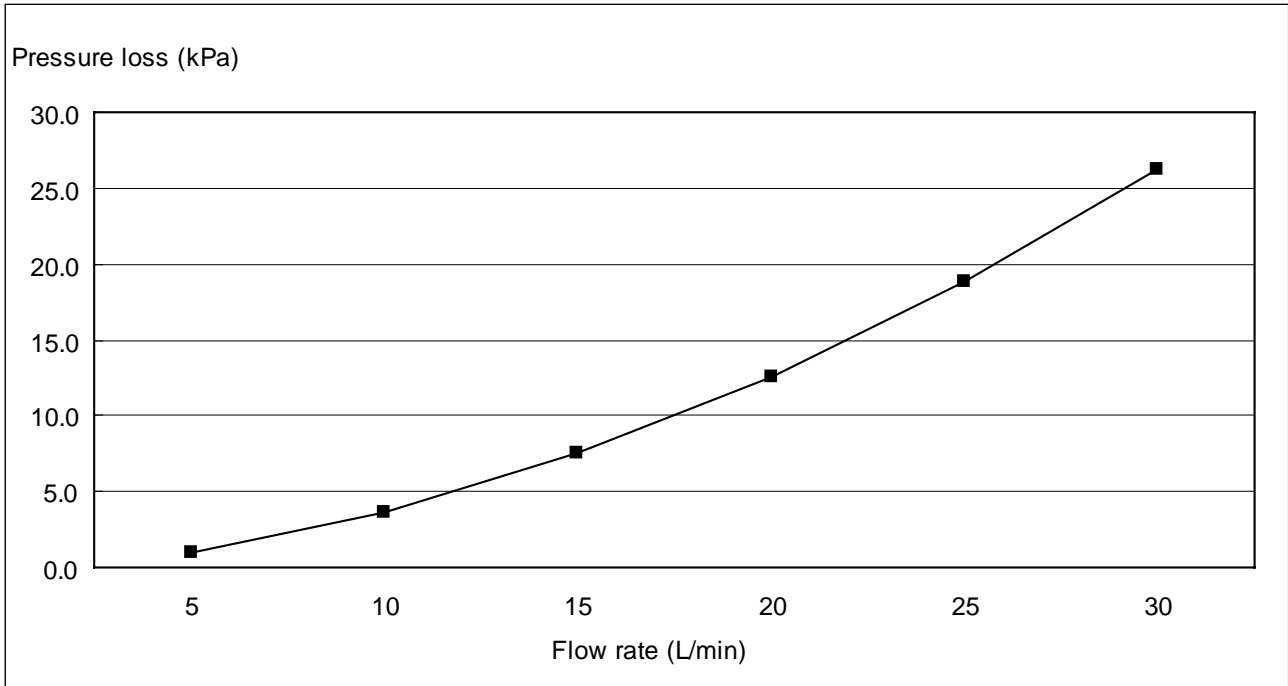

Hex for PUHZ-W112, 140VHA / YHA (ACH50-50Plates)

Secondary (Water - side)						
Flow rate (L/min)	15	30	45	60	75	90
Pressure Loss (kPa)	1.3	4.9	10.9	19.3	29.9	42.8

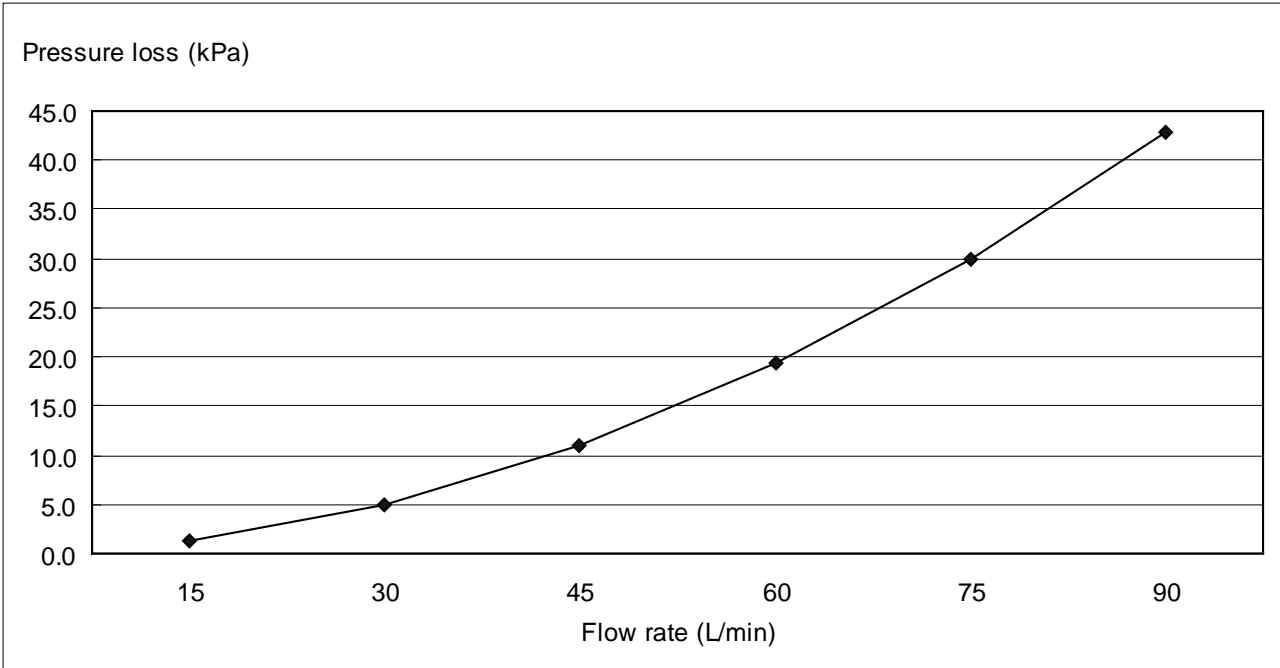

2

Heat pump unit_General information

2-1. Line-up

2-1-1. Outdoor unit for Air to water

(1) Packaged type: The Air to Water outdoor unit with a plate HEX (refrigerant-water) inside

Connectable models

Capacity (HP)	Packaged models		ZUBADAN-Packaged models	
	1-phase	3-phase	1-phase	3-phase
2	PUHZ-W50VHA	—	—	—
3	PUHZ-W85VHA	—	—	—
4	—	—	—	PUHZ-HW112YHA
5	—	—	PUHZ-HW140VHA	PUHZ-HW140YHA

(2) Split type: The standard outdoor unit without a plate HEX (refrigerant-water) inside

Connectable models

Capacity (HP)	Split Replace inverter models		Split ZUBADAN models	
	1-phase	3-phase	1-phase	3-phase
2.5	PUHZ-RP60VHA3#1	—	—	—
3	PUHZ-RP71VHA3#1	—	PUHZ-HRP71VHA(2)	—
4	PUHZ-RP100VHA3#1	PUHZ-RP100YHA3#1	PUHZ-HRP100VHA(2)	PUHZ-HRP100YHA(2)
5	PUHZ-RP125VHA2#2	PUHZ-RP125YHA2#2	—	PUHZ-HRP125YHA(2)
6	PUHZ-RP140VHA2#2	PUHZ-RP140YHA2#2	—	—

* Outdoor units (PUHZ-RP or PUHZ-P) other than the above-mentioned become possible by connecting TH5 (2-phase refrigerant temp. thermistor) with the interface only for Air to Air use.

2-1-2. Air to Air application

INTER FACE MODEL NAME		PAC-IF011B-E / PAC-IF010-E								
AUTO STEP *1	OUTDOOR UNIT	35	50	60	71	100	125	140	200	250
	PUHZ-HRP	—	—	—	VHA(2)	V/YHA(2)	YHA(2)	—	—	—
	PUHZ-RP	VHA3	VHA3	VHA3	VHA3	V/YHA3	V/YHA2	V/YHA2	YHA2	YHA2
	PUHZ-P	—	—	—	—	VHA2	VHA2	VHA2	YHA	YHA
	SUZ-KA	VA	VA	VA	VA	—	—	—	—	—
MANUAL STEP *2	OUTDOOR UNIT	35	50	60	71	100	125	140	200	250
	PUHZ-HRP	—	—	—	VHA	V(Y)HA	YHA	—	—	—
	PUHZ-RP	VHA3	VHA3	VHA3	VHA3	V/YHA3	V/YHA2	V/YHA2	YHA2	YHA2

MANUAL STEP MODE is New function of INTER FACE (Fixed capacity = Compressor frequency (Hz) fixed mode) .

2 Phase (Gas/Liquid) pipe thermistor is required (TH5).

Also, Interface P.C.B. SW2-6 need to be set "OFF (No LEV self control mode)" .

<Old models : The models that are not described in the table above.>

*1: With(Auto-mode)+(SW2-6 is OFF)+(2phase thermistor), all A-control outdoor units are able to connect to PAC-IF010/011B-E only for Air to Air use.

*2: With(Manual-mode)+(SW2-6 is OFF)+(2phase thermistor), from following RP type outdoor units are able to connect to PAC-IF010/011B-E only for Air to Air use.

PUHZ-RP35V, 50V, 60V, 71V,100V/Y,125V/Y,140V/YHA2₁

PUHZ-RP200Y, 250YHA₂



2-1-3. Reference manual

Outdoor unit	Service manual	Parts catalog
PUHZ-W50VHA PUHZ-W85VHA PUHZ-HW112YHA PUHZ-HW140VHA PUHZ-HW140YHA PUHZ-RP60VHA3#1 PUHZ-RP71VHA3#1 PUHZ-RP100VHA3#1	OCH439	OCB439
PUHZ-RP125VHA2#2 PUHZ-RP140VHA2#2 PUHZ-RP100YHA3#1 PUHZ-RP125YHA2#2 PUHZ-RP140YHA2#2	OC374	OC374
PUHZ-HRP71VHA(2) PUHZ-HRP100VHA(2) PUHZ-HRP100YHA(2) PUHZ-HRP125YHA(2)	OCH425	OCB425

	Type	Model name	Parts catalog
I/F	cased	PAC-IF011B-E	OCB427
	PCB only	PAC-IF010-E	—
FTC	cased	PAC-IF021B-E	OCB427
	PCB only	PAC-IF020-E	—

2-2. Data

2-2-1. Packaged type

Refer to each model's service manual.

2-2-2. Split

[1] Specifications(Reference data(connect to plate heat exchanger))

Rating conditions

Nominal operating condition	
Heating (A2/W35)	
Outside air temperature (Dry-bulb)	+2°C
Outside air temperature (Wet-bulb)	+1°C
Water temperature (inlet/outlet)	+30/+35°C
Heating (A7/W35)	
Outside air temperature (Dry-bulb)	+7°C
Outside air temperature (Wet-bulb)	+6°C
Water temperature (inlet/outlet)	+30/+35°C
Heating (A7/W45)	
Outside air temperature (Dry-bulb)	+7°C
Outside air temperature (Wet-bulb)	+6°C
Water temperature (inlet/outlet)	+40/+45°C

(1) PUHZ-HRP • V/YHA2

Outdoor unit		
Model name		PUHZ-HRP71VHA2
Power supply (Phase, Voltage, Frequency)		1 ϕ , 230V, 50Hz
Breaker size	A	32
Nominal water flow		L/min 22.9
Heating (A2/W35)	Capacity	kW 8.00
	COP 3.24	
	Power input 2.47	
Heating (A7/W35)	Capacity	kW 8.00
	COP 4.40	
	Power input 1.82	
Heating (A7/W45)	Capacity	kW 8.00
	COP 3.24	
	Power input 2.47	

Outdoor unit		
Model name		PUHZ-HRP100VHA2 / PUHZ-HRP100YHA2
Power supply (Phase, Voltage, Frequency)		1 ϕ , 230V, 50Hz / 3 ϕ , 400V, 50Hz
Breaker size	A	40 / 16
Nominal water flow		L/min 32.1
Heating (A2/W35)	Capacity	kW 11.20
	COP 3.02	
	Power input 3.71	
Heating (A7/W35)	Capacity	kW 11.20
	COP 4.26	
	Power input 2.63	
Heating (A7/W45)	Capacity	kW 11.20
	COP 3.24	
	Power input 3.46	
Heating (A7/W55)	Capacity	kW 11.20
	COP 2.40	
	Power input 4.67	

Outdoor unit		
Model name		PUHZ-HRP125YHA2
Power supply (Phase, Voltage, Frequency)		3 ϕ , 400V, 50Hz
Breaker size	A	16
Nominal water flow		L/min 40.1
Heating (A2/W35)	Capacity	kW 14.00
	COP 2.70	
	Power input 5.19	
Heating (A7/W35)	Capacity	kW 14.00
	COP 4.22	
	Power input 3.32	
Heating (A7/W45)	Capacity	kW 14.00
	COP 3.20	
	Power input 4.38	

Guaranteed operating range (Outdoor)

Heating	°C	-25 ~ +35
Cooling	°C	-5 ~ +46

Plate heat exchanger

ALFA LAVAL
ACH50

A: 50 mm
B: 466 mm

W: 112 mm
H: 526 mm
D: 130 mm
50 plates

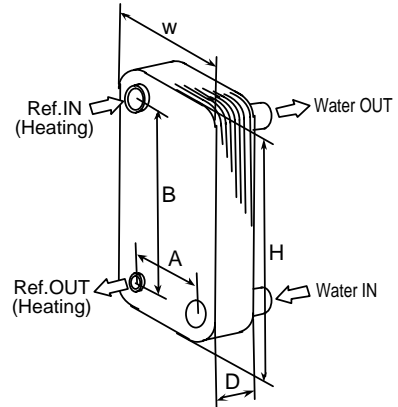

Refrigerant piping length from outdoor unit to heat exchanger (Water HEX): 5m

Maximum outlet water temperature

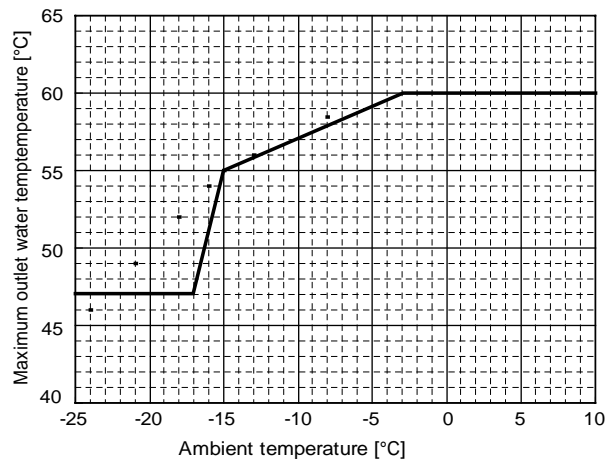

The performance might be decreased by the refrigerant piping length, insulation of refrigerant piping and heat exchanger (Water HEX).

(2) PUAZ-RP • VHA3/YHA3(2)

Outdoor unit		
Model name		PUAZ-RP60VHA3#1
Power supply (Phase, Voltage, Frequency)		1φ, 230V, 50Hz
Breaker size	A	25
Nominal water flow		L/min 20.1
Heating (A2/W35)	Capacity	kW 6.80
	COP 2.94	
	Power input	kW 2.31
Heating (A7/W35)	Capacity	kW 7.00
	COP 4.29	
	Power input	kW 1.63
Heating (A7/W45)	Capacity	kW 7.00
	COP 3.27	
	Power input	kW 2.14

Outdoor unit		
Model name		PUAZ-RP71VHA3#1
Power supply (Phase, Voltage, Frequency)		1φ, 230V, 50Hz
Breaker size	A	25
Nominal water flow		L/min 22.9
Heating (A2/W35)	Capacity	kW 7.50
	COP 2.92	
	Power input	kW 2.57
Heating (A7/W35)	Capacity	kW 8.00
	COP 4.21	
	Power input	kW 1.90
Heating (A7/W45)	Capacity	kW 8.00
	COP 3.20	
	Power input	kW 2.50

Guaranteed operating range (Outdoor)

Heating	°C	-11 ~ +35
Cooling	°C	-5 ~ +46

Plate heat exchanger

ALFA LAVAL
ACH50

A: 50 mm
B: 466 mm

W: 112 mm
H: 526 mm
D: 82 mm
30 plates

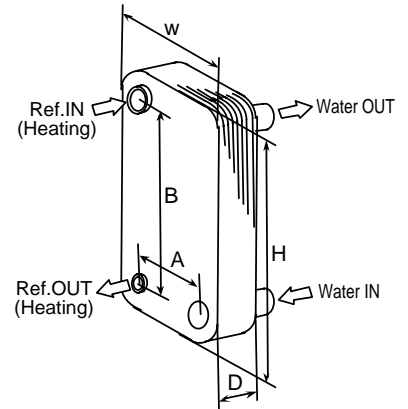

Refrigerant piping length from outdoor unit to heat exchanger (Water HEX): 5m

Maximum outlet water temperature

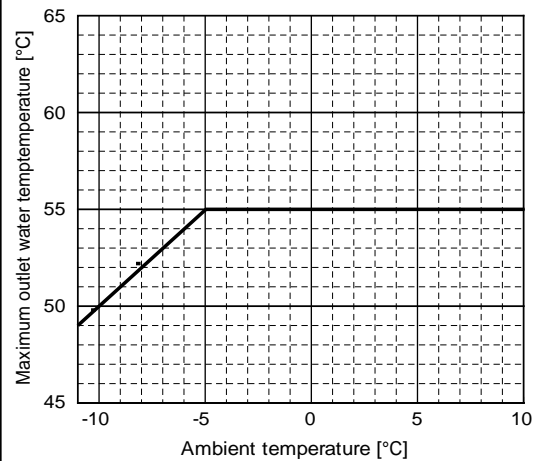

The performance might be decreased by the refrigerant piping length, insulation of refrigerant piping and heat exchanger (Water HEX).

Outdoor unit			
Model name	PUHZ-RP100VHA3#1 / PUHZ-RP100YHA3#1		
Power supply (Phase, Voltage, Frequency)	1 ϕ , 230V, 50Hz / 3 ϕ , 400V, 50Hz		
Breaker size	A	32 / 16	
Nominal water flow	L/min	32.1	
Heating (A2/W35)	Capacity	kW	10.50
	COP		2.90
	Power input	kW	3.62
Heating (A7/W35)	Capacity	kW	11.20
	COP		4.21
	Power input	kW	2.66
Heating (A7/W45)	Capacity	kW	11.20
	COP		3.20
	Power input	kW	3.50

Outdoor unit			
Model name	PUHZ-RP125VHA2#2 / PUHZ-RP125YHA2#2		
Power supply (Phase, Voltage, Frequency)	1 ϕ , 230V, 50Hz / 3 ϕ , 400V, 50Hz		
Breaker size	A	32/16	
Nominal water flow	L/min	40.1	
Heating (A2/W35)	Capacity	kW	11.50
	COP		2.70
	Power input	kW	4.26
Heating (A7/W35)	Capacity	kW	14.00
	COP		4.15
	Power input	kW	3.37
Heating (A7/W45)	Capacity	kW	14.00
	COP		3.10
	Power input	kW	4.51

Outdoor unit			
Model name	PUHZ-RP140VHA2#2 / PUHZ-RP140YHA2#2		
Power supply (Phase, Voltage, Frequency)	1 ϕ , 230V, 50Hz / 3 ϕ , 400V, 50Hz		
Breaker size	A	40/16	
Nominal water flow	L/min	45.9	
Heating (A2/W35)	Capacity	kW	11.70
	COP		2.69
	Power input	kW	4.35
Heating (A7/W35)	Capacity	kW	16.00
	COP		3.90
	Power input	kW	4.10
Heating (A7/W45)	Capacity	kW	16.00
	COP		3.00
	Power input	kW	5.34

Guaranteed operating range (Outdoor)

Heating	°C	-20 ~ +35
Cooling	°C	-5 ~ +46

Plate heat exchanger

ALFA LAVAL
ACH50

A: 50 mm
B: 466 mm

W:112 mm
H: 526 mm
D: 130 mm
50 plates

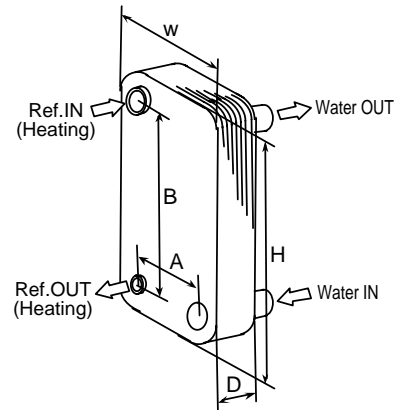

Refrigerant piping length from outdoor unit to heat exchanger (Water HEX): 5m

Maximum outlet water temperature

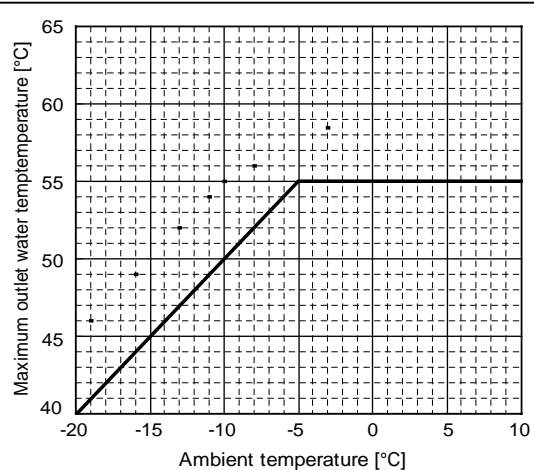

The performance might be decreased by the refrigerant piping length, insulation of refrigerant piping and heat exchanger (Water HEX).

[2] Standard operation data <Split> Reference data (connect to Plate HEX)

(1) PUHZ-HRP • V/YHA2

Mode			ACH50-50 plates						
			Cooling (A35/W7)	Heating (A7/W35)	Cooling (A35/W7)	Heating (A7/W35)	Cooling (A35/W7)	Heating (A7/W35)	
Total	Capacity	W	7,100	8,000	10,000	11,200	12,500	14,000	
	Input	kW	2.20	1.82	3.67	2.61	4.80	3.50	
Electrical circuit	Outdoor unit		PUHZ-HRP71VHA2		PUHZ-HRP100VHA2/ PUHZ-HRP100YHA2		PUHZ-HRP125YHA2		
	Phase, Hz		1, 50		1/3, 50		3, 50		
	Voltage	V	230		230 / 400		400		
	Current	A	9.9	8.2	16.5/5.6	11.7/4.0	7.3	5.3	
Refrigerant circuit	Discharge pressure	MPa	2.4	2.0	2.6	2.1	2.8	2.3	
	Suction pressure	MPa	0.8	0.7	0.8	0.7	0.8	0.7	
	Discharge temperature	°C	70	60	78	63	84	70	
	Condensing temperature	°C	42	35	46	36	47	39	
	Suction temperature	°C	12	6	11	4	10	3	
	Evaporating temperature	°C	5	2	5	2	5	1	
	Evaporator inlet temperature	°C	5	—	5	—	5	—	
	Evaporator outlet temperature	°C	5	—	5	—	5	—	
	Condenser inlet temperature	°C	—	55	—	60	—	65	
Condenser outlet temperature	°C	—	33	—	31	—	30		
Water conditions	Flow volume	L/min	20.4	22.9	28.7	34.4	35.8	40.1	
	Outlet water temperature	°C	7	35	7	35	7	35	
Outdoor conditions	Intake air temperature	D.B.	°C	35	7	35	7	35	7
		W.B.	°C	24	6	24	6	24	6

The unit of pressure has been changed to MPa based on international SI system.
The conversion factor is : 1(MPa)=10.2(kgf/cm²)

(2) PUAZ-RP • VHA3/YHA3(2)

Mode			ACH50-30 plates				ACH50-50 plates		
			Cooling (A35/W7)	Heating (A7/W35)	Cooling (A35/W7)	Heating (A7/W35)	Cooling (A35/W7)	Heating (A7/W35)	
Total	Capacity	W	6,000	7,000	6,600	8,000	9,100	11,200	
	Input	kW	2.31	1.63	2.59	1.90	3.31	2.66	
Electrical circuit	Outdoor unit		PUHZ-RP60VHA3#1		PUHZ-RP71VHA3#1		PUHZ-RP100VHA3#1/ PUHZ-RP100YHA3#1		
	Phase, Hz		1, 50		1, 50		1/3, 50		
	Voltage	V	230		230		230 / 400		
	Current	A	10.3	7.2	11.4	8.4	14.5 / 5.1	11.8 / 4.1	
Refrigerant circuit	Discharge pressure	MPa	2.7	2.1	2.7	2.2	2.6	2.1	
	Suction pressure	MPa	0.8	0.7	0.8	0.7	0.8	0.7	
	Discharge temperature	°C	70	65	70	66	74	65	
	Condensing temperature	°C	45	36	45	36	44	36	
	Suction temperature	°C	4	5	4	2	6	5	
	Evaporating temperature	°C	5	1	5	1	5	1	
	Evaporator inlet temperature	°C	6	—	6	—	5	—	
	Evaporator outlet temperature	°C	5	—	5	—	5	—	
	Condenser inlet temperature	°C	—	56	—	57	—	58	
	Condenser outlet temperature	°C	—	34	—	33	—	35	
Water conditions	Flow volume	L/min	17.2	20.1	18.9	22.9	26.1	32.1	
	Outlet water temperature	°C	7	35	7	35	7	35	
Outdoor conditions	Intake air temperature	D.B.	°C	35	7	35	7	35	7
		W.B.	°C	24	6	24	6	24	6

The unit of pressure has been changed to MPa based on international SI system.

The conversion factor is : 1(MPa)=10.2(kgf/cm²)



Mode			ACH50-50 plates				
			Cooling (A35/W7)	Heating (A7/W35)	Cooling (A35/W7)	Heating (A7/W35)	
Total	Capacity	W	12,000	14,000	12,500	16,000	
	Input	kW	5.10	3.37	5.38	4.10	
Electrical circuit	Outdoor unit		PUHZ-RP125VHA2#2/ PUHZ-RP125YHA2#2		PUHZ-RP140VHA2#2/ PUHZ-RP140YHA2#2		
	Phase, Hz		1 / 3, 50		1 / 3, 50		
	Voltage	V	230 / 400		230 / 400		
	Current	A	22.4 / 7.6	15.0 / 5.2	23.6 / 8.1	18.2 / 6.2	
Refrigerant circuit	Discharge pressure	MPa	2.8	2.1	2.8	2.2	
	Suction pressure	MPa	0.7	0.7	0.7	0.7	
	Discharge temperature	°C	80	69	81	67	
	Condensing temperature	°C	46	36	46	36	
	Suction temperature	°C	3	4	3	1	
	Evaporating temperature	°C	5	-1	5	-1	
	Evaporator inlet temperature	°C	6	—	6	—	
	Evaporator outlet temperature	°C	5	—	5	—	
	Condenser inlet temperature	°C	—	63	—	61	
Condenser outlet temperature	°C	—	35	—	34		
Water conditions	Flow volume	L/min	34.4	40.1	35.8	45.9	
	Outlet water temperature	°C	7	35	7	35	
Outdoor conditions	Intake air temperature	D.B.	°C	35	7	35	7
		W.B.	°C	24	6	24	6

The unit of pressure has been changed to MPa based on international SI system.
The conversion factor is : 1(MPa)=10.2(kgf/cm²)

[4] Capacity correction curves (Refrigerant piping length)

Cooling and heating capacity is lowered according to pipe length. Capacity can be obtained by referring to the capacity curves below.

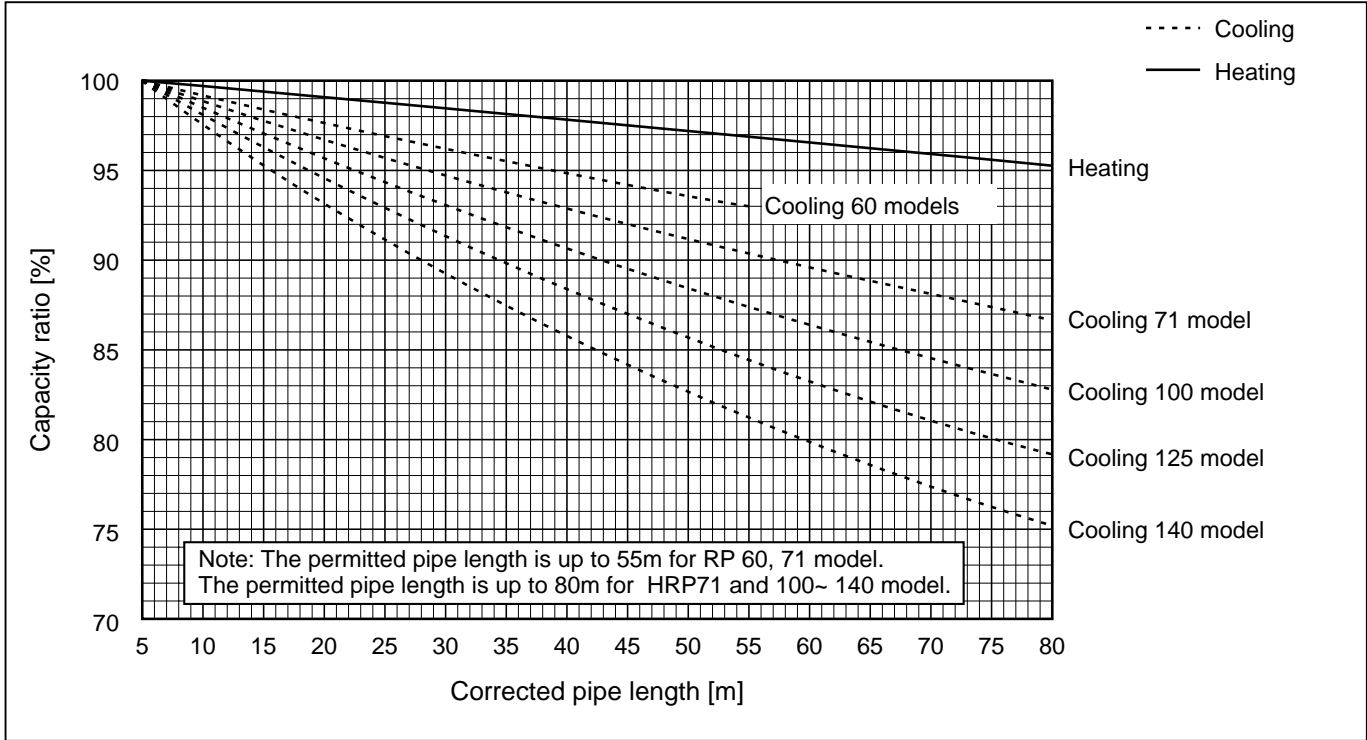

[5] Refrigerant circuit diagram (Representative pattern)

PUHZ-HRP • V/YHA2 + Plate HEX (ACH50) + FTC (TH1/2)

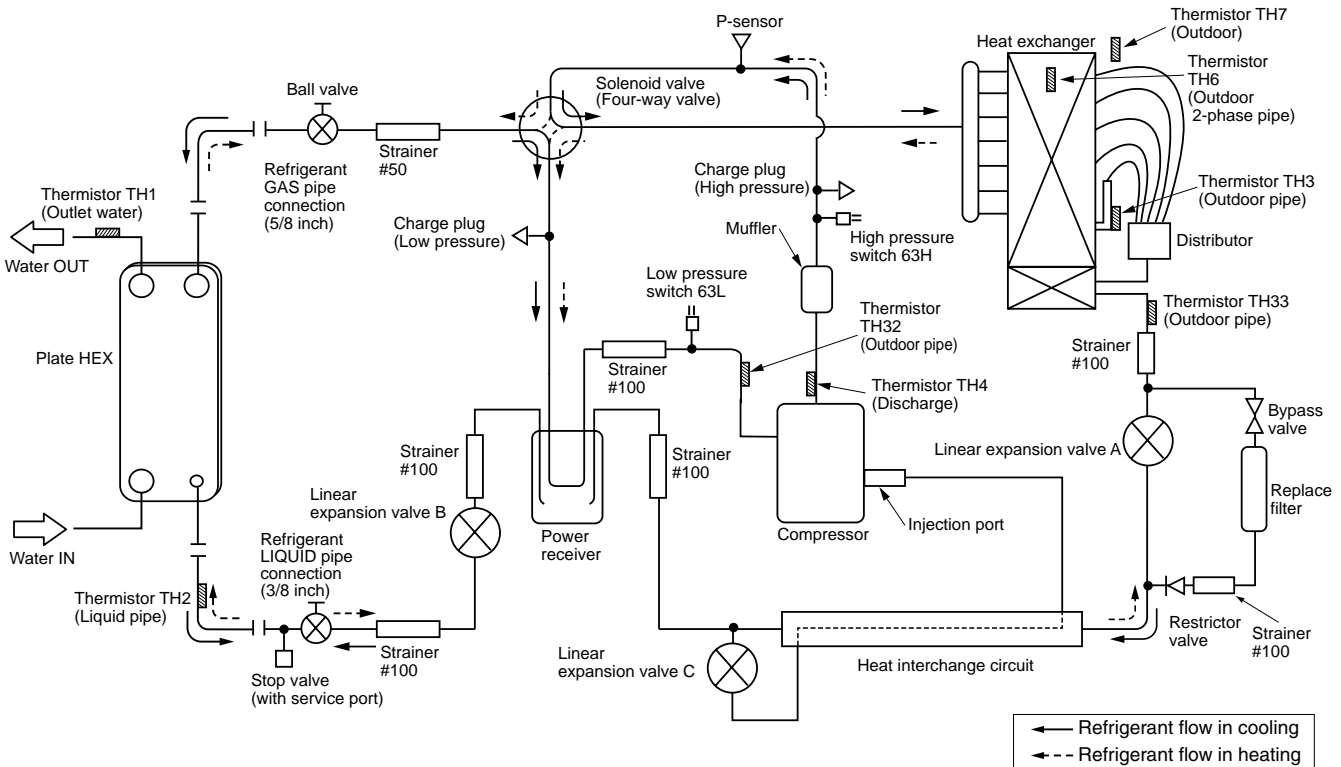



[6] Notification to design/select HEX (Refrigerant - Water) Warranty for SPILIT solution

- Specifications of AHU and compatibility with regulations must be confirmed by your company.
- Selection of an appropriate AHU (with appropriate specifications to match those of units connected to the AHU such as configuration, dimension, life-span, vibration, noise level, or features) must be made by your company.
- Mitsubishi Electric shall not be liable for any damage to the entire system or the AHU main body caused by connected AHU with wrong specification or wrong usage of AHU.
- Mitsubishi Electric shall not be liable for any damage to the outdoor units caused by AHU damage. (AHU : hydro box or refrigerant - water HEX)

Heat exchanger

- (1) Withstanding pressure
Designed pressure of outdoor unit is 4.15 MPa. Following must be satisfied for burst pressure of connecting application.
Burst pressure : More than 12.45 MPa (3 times more than designed pressure)
- (2) Performance
Secure the heat exchanger capacity which meets the following conditions. If the conditions are not met, it may result in malfunction caused by the protection operation or the outdoor unit may be turned off due to the operation of protection system.
1. Evaporate temperature is more than 4: in max. frequency operation under *1 the cooling rated conditions.
 2. In case of hot water supply, condense temperature is less than 58°C in max. frequency operation with the outside temperature 7°C D.B./6°C W.B.
*1. Outdoor: 35°C D.B./24°C W.B.

- (3) Heat exchanger internal capacity
Heat exchanger internal capacity must be within the capacity range shown below. If the heat exchanger below the minimum capacity is connected, it may result in the back flow of liquid or the failure of the compressor.
If the heat exchanger above the maximum capacity is connected, it may result in the deficiency in performance due to lack of refrigerant or overheating of the compressor.
Minimum capacity : 10 x Model capacity [cm³] / Maximum capacity : 30 x Model capacity [cm³]
e.g. When connecting to PUAZ-HRP100 VHA2
Minimum capacity : 10 x 100 = 1000 cm³
Maximum capacity : 30 x 100 = 3000 cm³

Model capacity	60(2.5HP)	71(3HP)	100(4HP)	125(5HP)	140(6HP)
Maximum capacity [cm ³]	1800	2130	3000	3750	4200
Minimum capacity [cm ³]	600	710	1000	1250	1400

- (4) Contamination maintenance
1. Wash the inside of heat exchanger to keep it clean. Be sure to rinse not to leave flux. Do not use chlorine detergent for wash.
 2. Be sure that the amount of contamination per unit cubic content of heat transfer pipe is less than the following amount.
Example) In case of ϕ 9.52mm
Residual water : 0.6mg/m, Residual oil : 0.5mg/m, Solid foreign object : 1.8mg/m

Note:

- Install the hydraulic filter at the water intake.
- Use the inlet water of higher than 5 °C and lower than 55 °C.
- The water in a system should be clean and with pH value of 6.5-8.0.
- The followings are the maximum values;
Calcium : 100mg/L
Chlorine : 100mg/L
Iron/manganese : 0.5mg/L
- Refrigerant pipe diameter from outdoor unit to refrigerant-water HEX (Only for SPLIT type)
Use the pipe with same diameter size as the refrigerant pipe connection diameter of outdoor unit.(Refer to outdoor unit installation manual.)
- Make sure to perform the frozen prevention measure for water pipe system.(Water piping insulation, back-up pump system, using of a certain % ethylene glycol instead of normal water)

[Reference]

TB142 has for “Forced Comp. OFF” function as the EXTERNAL INPUT(Contact signal).
To input the abnormal signal of water pump or the abnormal lowering of water flow amount with non-voltage contact signal makes the outdoor unit stop forcibly. For details, refer to each part of I/F or FTC on this manual.

- The water velocity in pipes should be kept within certain limits of material to avoid erosion, corrosion and excessive noise generation.
Be aware, and take care of, that local velocities in small pipes, bends and similar obstructions can exceed the values of previous page.
e.g.) Copper : 1.5m/s

⚠ Warning

- Use clean enough water which meets water quality standards. The deterioration of water quality may result in the system breakdown or the water leakage.
- Never use anything other than water as a medium. It may cause a fire or an explosion.
- Do not use heated or cooled water that is produced by the air to water heat pump directly for drinking or cooking. There is a risk to damage your health. There is also a risk that installing the water heat exchanger may corrode if the necessary water quality for air to water heat pump system cannot be maintained. If you wish to use the heated or cooled water from the heated pump for these purposes, take measure such as to the second heat exchanger within the water piping system.

Reference data

Required specification and performance of Plate Heat Exchanger.

Required specification

Refrigerant side	Refrigerant type	R410A
	Normal (designed) pressure	4.15MPa
	Operating temperature	-20~100°C
Water side	Refrigerant type	Clean water
	Normal (designed) pressure	1.5MPa
	Operating temperature	-20~90°C (No freezing)
Burst pressure	12.45MPa (4.15MPa x3) or more	
Frozen performance	Satisfy an initial performance since 5 times or more of deep freezing.	
Heat cycle	70,000 times or more...Temperature difference: about 50K	
Endurance pressure	72,000 times or more...Pressure difference: 3.3MPa (0 ↔ 3.3MPa)	

Required performance

< For 2.5~3 HP >

Required performance of Plate Heat Exchanger		kW	9.0	9.0	
Refrigerant side (R410A)	Inlet temperature	degC	75	100	Gas pipe: φ12.7mm Liquid pipe: φ9.52mm
	Condensing temperature	degC	39.5	63.5	
	Subcool	degC	2	2	
	Max. pressure loss	kPa	50	50	
Water side	Inlet temperature	degC	30	55	Inlet / outlet pipe: φ28.6mm
	Outlet temperature	degC	35	60	
	Water flow volume	L/min	25.8	25.8	
	Max. pressure loss	kPa	50	50	

* For heating mode, used at counter flow direction between refrigerant flow and water one.

< For 4~6 HP >

Required performance of Plate Heat Exchanger		kW	14.0	14.0	
Refrigerant side (R410A)	Inlet temperature	degC	75	100	Gas pipe: φ15.88mm Liquid pipe: φ9.52mm
	Condensing temperature	degC	39.5	63.5	
	Subcool	degC	2	2	
	Max. pressure loss	kPa	50	50	
Water side	Inlet temperature	degC	30	55	Inlet / outlet pipe: over φ28.6mm
	Outlet temperature	degC	35	60	
	Water flow volume	L/min	40.1	40.1	
	Max. pressure loss	kPa	50	50	

* For heating mode, used at counter flow direction between refrigerant flow and water one.

3-1. System type

* with step I/F by digital/analog signals
 * with FTC simple/basic/analog temp.

Application	Capacity control	For	Model name	Type	
Air to Air	Local controller	Manufacturer	PAC-IF010-E *	STEP I/F	PCB only
		Individual installer	PAC-IF011B-E		Cased
	I/F	Manufacturer	PAC-IF010-E *		PCB only
		Individual installer	PAC-IF011B-E		Cased
Air to Water	Local controller	Manufacturer	PAC-IF010-E *	FTC	PCB only
		Individual installer	PAC-IF011B-E		Cased
	FTC	Manufacturer	PAC-IF020-E *		PCB only
		Individual installer	PAC-IF021B-E		Cased with R/C

* PAC-IF010-E, PAC-IF020-E : PCB 10pcs/set

3-2. Combination of remote controller

Remote controller model	Connected object	Connectability
PAR-21MAA (Standard)	I/F	OK
	FTC	NG (Continue to indicate "PLEASE WAIT")
PAR-W21MAA (Only for FTC)	I/F	NG (Continue to indicate "PLEASE WAIT")
	FTC	OK
PAR-20MAA (Standard) (Old)	I/F	NG (Continue to indicate "PLEASE WAIT")
	FTC	NG (Continue to indicate "PLEASE WAIT")

3-3. Flow chart to check system type

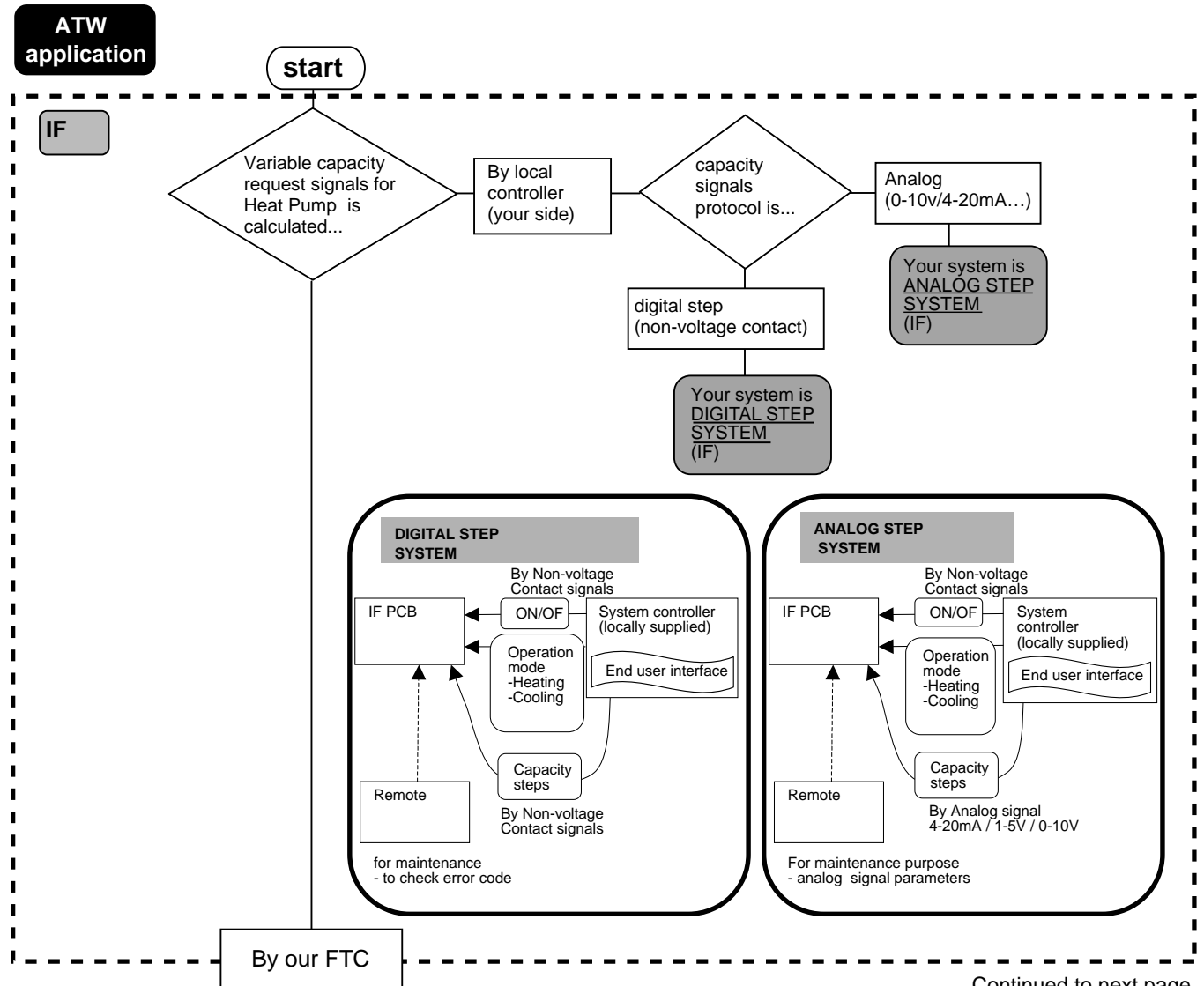



FTC

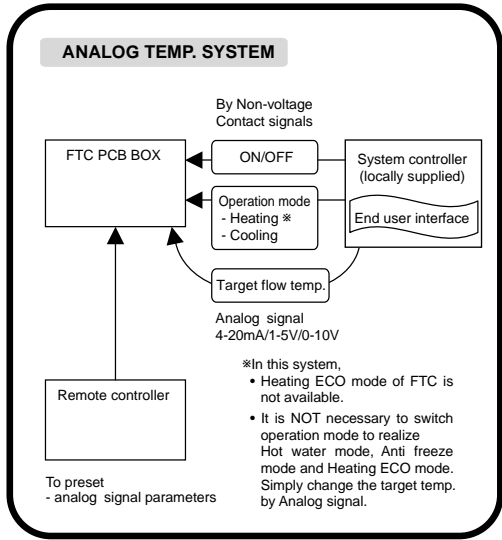
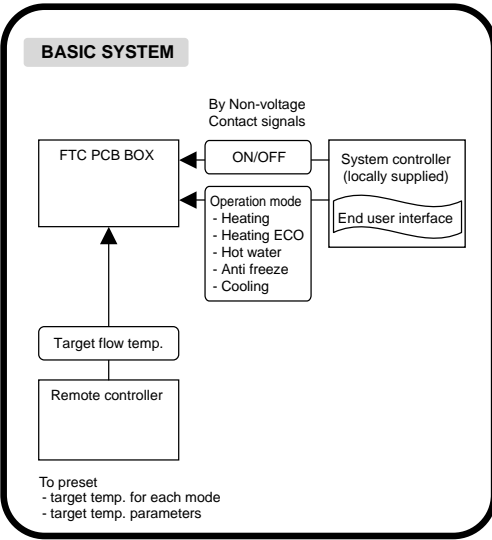
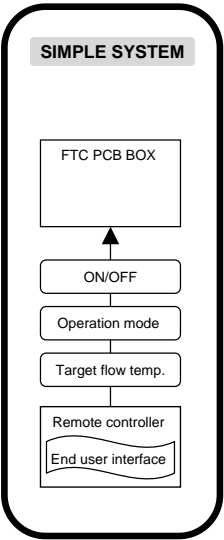
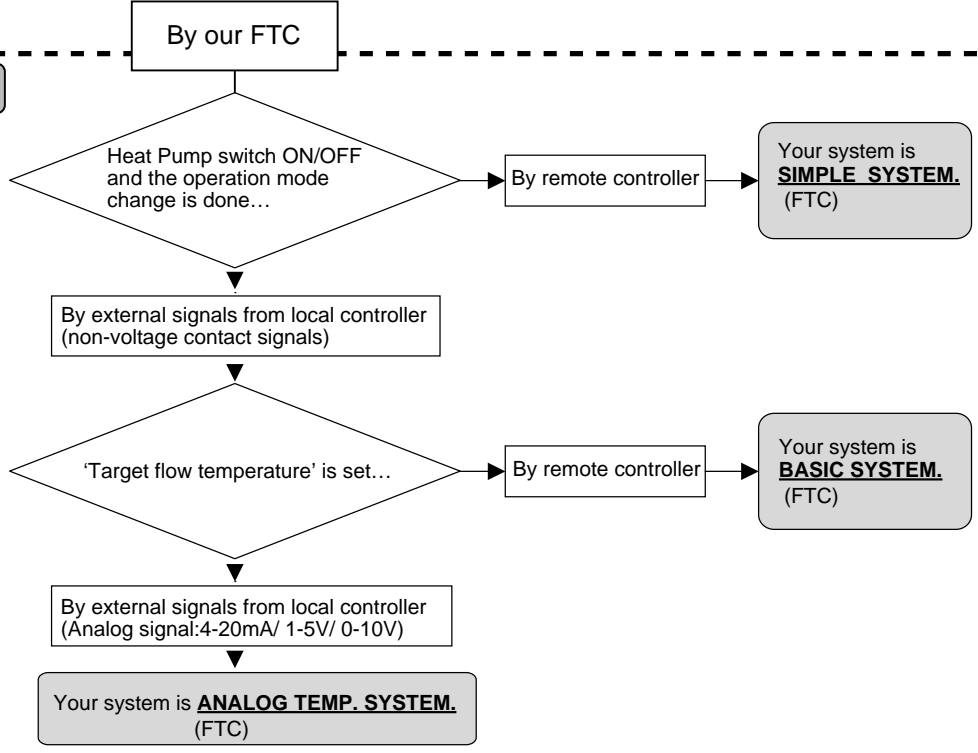

ATA application

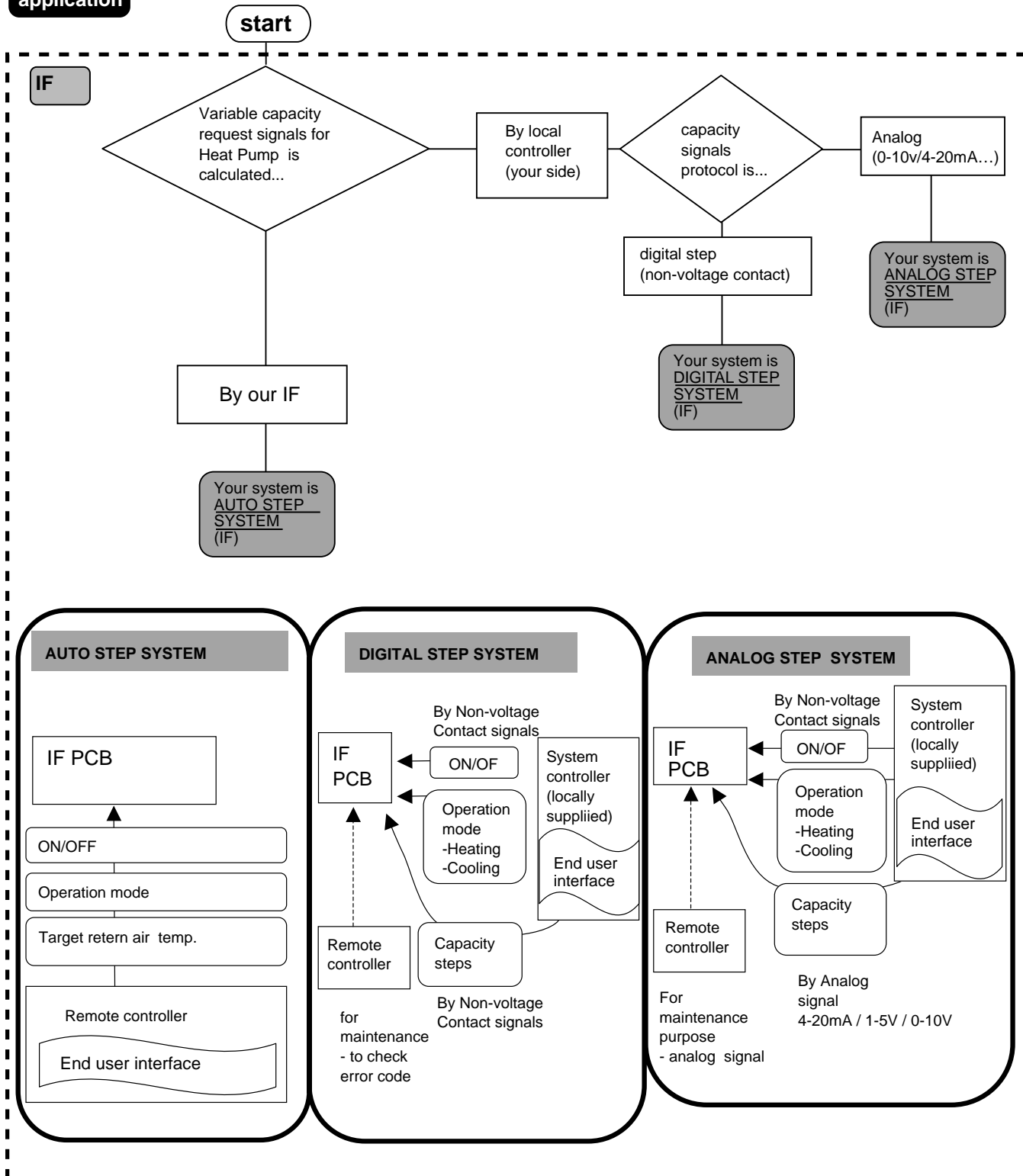

3-4. Wiring diagram

(1) PAC-IF011B-E(I/F)

1. Symbols used in wiring diagram are, : Connector, : Terminal block.
 2. Interface controller and outdoor connecting wires have polarities, make sure to match terminal numbers(S1, S2, S3) for correct wirings.
 3. Since the outdoor side electric wiring may change, be sure to check the outdoor unit electric wiring diagram for servicing.
 4. This diagram shows the wiring of Interface controller and outdoor connecting wires:(specification of 230V), adopting superimposed system of power and signal.
- *1 : When work to supply power separately to interface controller and outdoor units was applied, refer to Fig 1.
*2 : Remove the short-circuited connector CNS2 when work to supply power separately to interface controller and outdoor units was applied.

SYMBOL	NAME
INTERFACE CONTROLLER	
TB6	TERMINAL BLOCK(INTERFACE/OUTDOOR CONNECTING LINE)
TB141	TERMINAL BLOCK (External Output)
TB142	TERMINAL BLOCK (External Input REMOTE SWITCH)
TB62	TERMINAL BLOCK (External Input)
TB61	THERMISTOR(TARGET PIPE)
LED1	POWER SUPPLY(I/F)
LED2-5	OPERATION INDICATION
FUSE	FUSE(T3.15A/250V)
SW1	SWITCH(Input selection of inverter capacity setting)*See table 4.
SW2	SWITCH(Function switch)*See table 5 and 6.
SW3	SWITCH(LED2-5 Display setting)
SW6	SWITCH(4-20mA/1-5V/0-10V switch)*See table 4.
ZNR01,02	VARISTOR
DSA	SURGE ABSORBER
X1-X6	RELAY
TH1	TARGET TEMP. THERMISTOR (0C/15kΩ, 25C/52kΩ DETECT)
TH2	PIPE TEMP. THERMISTOR/LIQUID (0C/15kΩ, 25C/52kΩ DETECT)
TH5	PIPE TEMP. THERMISTOR2-PHASE (0C/15kΩ, 25C/52kΩ DETECT)

SW1-1	SW1-2	SW1-3	SW6-1	SW6-2	Input	Step for capacity setting
OFF	OFF	OFF	OFF	OFF	TypeA(4bit-8 setting)	OFF/Step 1/Step 2/.../Step 7/Auto
ON	OFF	OFF	OFF	OFF	TypeB(1bit-1 setting)	OFF/Step 1/Step 4/Step 7/Auto
ON	ON	OFF	ON	ON	4-20mA	OFF/Step 1/Step 2/.../Step 7
ON	ON	OFF	ON	ON	1-5V	OFF/Step 1/Step 2/.../Step 7
OFF	OFF	ON	OFF	OFF	0-10V	OFF/Step 1/Step 2/.../Step 7
ON	OFF	ON	OFF	OFF	0-10kΩ	OFF/Step 1/Step 2/.../Step 7/Auto
OFF	ON	ON	OFF	OFF	No input(Auto mode)	Only Auto mode

SW2-1	SW2-2	Details
OFF	OFF	Not FIX (Depending on Remote controller setting)
ON	OFF	[Cooling]FIX
OFF	ON	[Heating]FIX
ON	ON	External input(Depending on TB142-3,4)

SW2-3	SW2-4	SW2-5	Details
OFF	OFF	OFF	Not fixed (Remote controller setting)
ON	OFF	OFF	Cooling 19 °C/Heating 17 °C FIX
OFF	ON	OFF	20 °C FIX
ON	ON	OFF	22 °C FIX
OFF	OFF	ON	24 °C FIX
ON	OFF	ON	26 °C FIX
OFF	ON	ON	28 °C FIX
ON	ON	ON	Cooling 30 °C / Heating 28 °C FIX

SW2-6	Details
OFF	Connect TH5
ON	Not connect TH5 (initial setting)

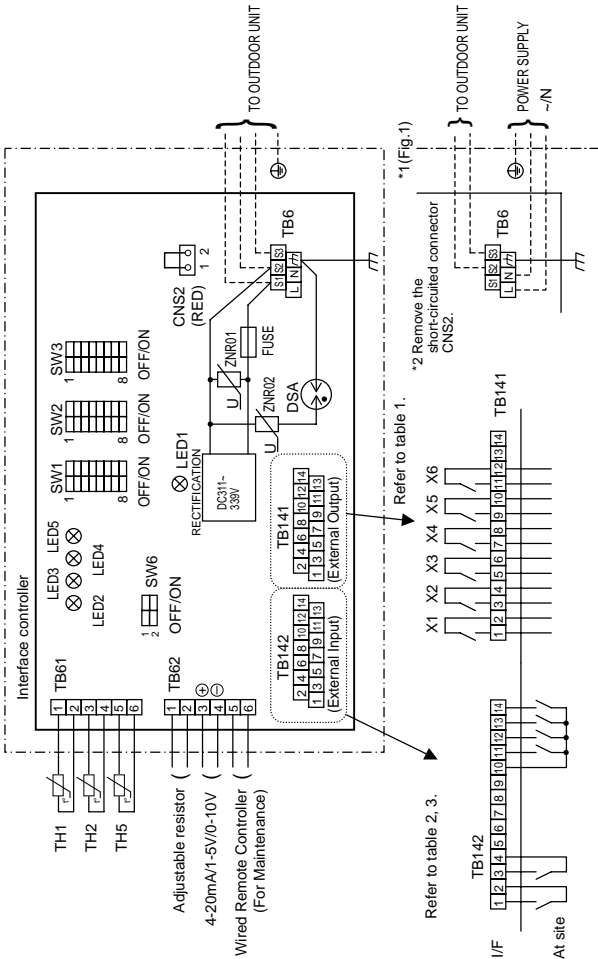

Item	Item	ON	OFF	Remark
1-2 (OUT1)	X1	Operation Output	OFF	ON
3-4 (OUT2)	X2	Error Output	Normal	Error
5-6 (OUT3)	X3	Comp. Output	OFF(Comp. OFF)	ON (Comp. ON)
7-8 (OUT4)	X4	Defrost Output	OFF	ON (Defrosting)
9-10 (OUT5)	X5	Mode(Cool) Output	OFF	ON (Cooling)
11-12 (OUT6)	X6	Mode(Heat) Output	OFF	ON (Heating)
13-14 (OUT7)	X6	Output	OFF	ON (Heating)

Item	Item	ON	OFF	Remark
1-2 (IN1)	Forced Comp.	OFF	Normal	Forced Comp. OFF
3-4 (IN2)	Fixed operation mode	Normal	Cooling	Heating

Item	Item	Step for capacity setting	Remark
TB142 10-11 (COM-INS)	TB142 10-13 (COM-IN7)	TypeA	Fixed capacity (Hz fixed) mode
OFF	OFF	0%	
ON	OFF	10%	
ON	OFF	20%	
ON	OFF	30%	
ON	OFF	50%	
ON	OFF	100%	
ON	ON	Auto	Auto mode

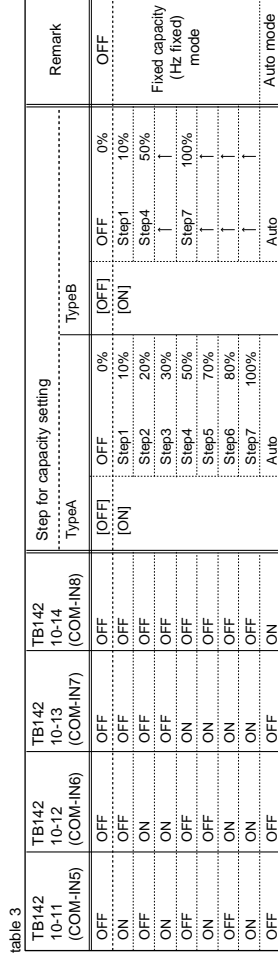

(2) PAC-IF021B-E(FTC)

Table 1 External input(Contact signal)

TB142	OFF	ON	Remark
1-2	(IN1)	—	Not in use
3-4	(IN2)	—	Not in use
5-6	(IN3)	Normal	Forced Comp. OFF SW3-6=OFF SW3-6=ON
7-8	(IN4)	OFF	Cooling
10-11	(COM-IN5)	OFF	Heating
10-12	(COM-IN6)	OFF	Heating ECO
10-13	(COM-IN7)	OFF	Hot Water
10-14	(COM-IN8)	OFF	Anti-Freeze

Table 2 External output

TB141	Item	OFF	ON
1-2	(OUT1) Operation Output	OFF	ON
3-4	(OUT2) Error Output	Normal	Error
5-6	(OUT3) Comp. Output	OFF	ON
7-8	(OUT4) Defrost Output	OFF	ON
9-10	(OUT5) Mode(Cooling) Output	OFF	ON
11-12	(OUT6) Mode(Heating/HeatingECO/ Hot Water/ Anti-Freeze) Output	OFF	ON
13-14	(OUT7) —	—	—

Table 3 SW1, SW6 : Input selection

ON/OFF Input	Change mode input	Change TEMP. input	Outdoor unit *6	SW1-1	SW1-2	SW1-3	SW1-6	SW6-1	SW6-2
External input (non-voltage contact)	External input (non-voltage contact)	DIP switch on PCB SW2-1~8, SW3-1~3	SPLIT type	ON	OFF	ON	ON	OFF	OFF
External input (non-voltage contact)	External input (non-voltage contact)	Wired remote controller	PACKAGED type	ON	OFF	ON	ON	OFF	OFF
External input or 4-20mA *3	External input (non-voltage contact)	4-20mA	SPLIT type	ON	OFF	ON	ON	OFF	OFF
External input or 1-5V *4	External input (non-voltage contact)	1-5V	PACKAGED type	OFF	ON	OFF	OFF	ON	ON
External input	External input (non-voltage contact)	0-10V	SPLIT type	ON	OFF	ON	ON	OFF	OFF
External input and *5	External input (non-voltage contact)	DIP switch on PCB	PACKAGED type	ON	ON	ON	ON	OFF	OFF
Wired remote controller	Wired remote controller	SW2-1~8, SW3-1~3	PACKAGED type	OFF	OFF	ON	ON	OFF	OFF
External input and *5	External input and	Wired remote controller	SPLIT type	OFF	OFF	ON	ON	OFF	OFF
Wired remote controller	Wired remote controller	Wired remote controller	PACKAGED type	OFF	OFF	ON	ON	OFF	OFF
Wired remote controller	Wired remote controller	Wired remote controller	PACKAGED type	OFF	OFF	ON	ON	OFF	OFF
Wired remote controller	Wired remote controller	Wired remote controller	PACKAGED type	OFF	OFF	ON	ON	OFF	OFF

- *3. 0~2mA : STOP
- *4. 0~0.5V : STOP
- *5. The signal of external input is prior to the signal of wired remote controller.
- *6. SPLIT type : the standard outdoor unit without a plate HEX(refrigerant-water HEX) inside. PACKAGED type : the Air to water outdoor unit with a plate HEX(refrigerant-water HEX) inside. (It is not necessary to connect to TH2.)

Table 4 SW1-3 Prohibition of Cooling mode

SW1-3	Operation mode
OFF	Heating/Heating ECO/Hot water/Anti-freeze/Cooling
ON	Heating/Heating ECO/Hot water/Anti-freeze

Table 5 SW3-6 Logic of Forced comp. OFF external signal (TB142 5-6)

SW3-6	TB142 No.5-6 input	Item
OFF	ON(short)	Normal
ON	ON(short)	Forced Comp. OFF
ON	ON(short)	Normal

Table 6 SW1-6,7,8 Set temperature range

SW1-6=OFF	Set temperature range with wired remote controller
SW1-6=ON	Set temperature range with DIP switch of FTC

Table 7 SW1-6 (SW1-7 SW1-8) Temperature range with wired remote controller

SW1-6	SW1-7	SW1-8	Temperature range with wired remote controller	Temperature table
OFF	OFF	OFF	Heating/HeatingECO/Hot Water Anti-Freeze	SW2-1~8, SW3-1~3
OFF	ON	OFF	Upper 45°C / lower 5°C	Upper 25°C / lower 5°C
OFF	ON	ON	Upper 60°C / lower 20°C *7	Upper 25°C / lower 5°C
OFF	ON	ON	Upper 50°C / lower 20°C	Upper 45°C / lower 5°C
ON	ON	ON	Upper 45°C / lower 20°C	Upper 25°C / lower 5°C
ON	ON	OFF	—	Table① *8
ON	ON	OFF	—	Table② *8
ON	ON	ON	—	—

- *7. Don't use this setting when using the SPLIT type outdoor unit.
- *8. Refer to installation manual.

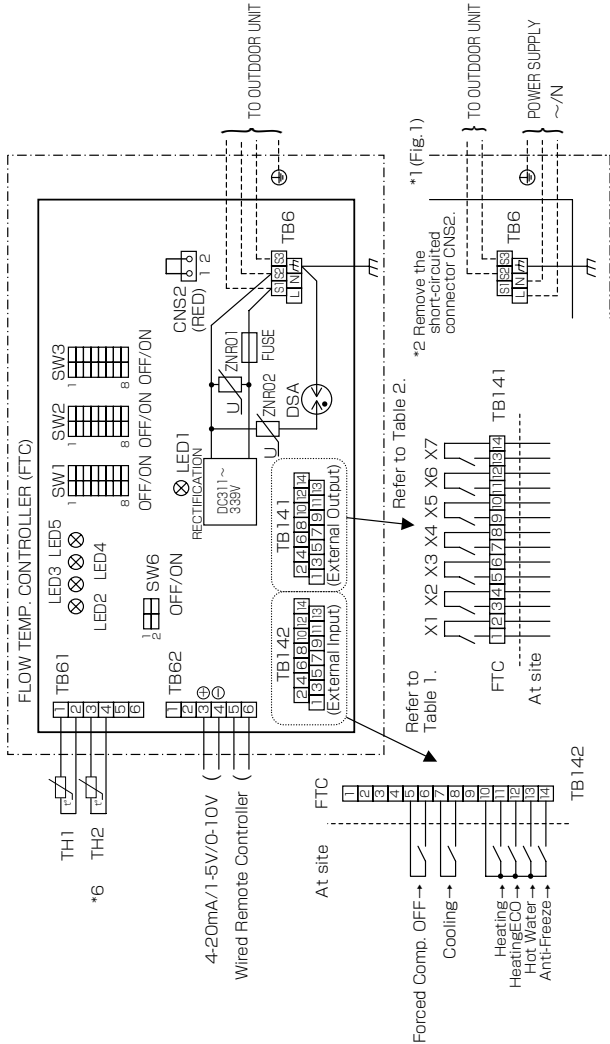

- Symbols used in wiring diagram are: : Connector, : Terminal block.
- FTC and outdoor unit connecting wires have polarities, make sure to match terminal numbers(S1, S2, S3) for correct wirings.
- Since the outdoor unit side electric wiring may change, be sure to check the outdoor unit electric wiring diagram for servicing.
- This diagram shows the wiring of FTC and outdoor unit connecting wires (specification of 230V), adopting superimposed system of power and signal.
- *1: Remove the short-circuited connector CNS2 when work to supply power separately to FTC and outdoor unit was applied, refer to Fig. 1.
- *2: Remove the short-circuited connector CNS2 when work to supply power separately to FTC and outdoor unit was applied.

SYMBOL	NAME
FLOW TEMP. CONTROLLER(FTC)	
TB6	TERMINAL BLOCK(FTC/OUTDOOR UNIT CONNECTING LINE)
TB141	TERMINAL BLOCK (External Output)
TB142	TERMINAL BLOCK (External Input Contact signal)
TB62	TERMINAL BLOCK (External Input Analog signal)
TB61	TERMINAL BLOCK (Thermistor)
LED1	POWER SUPPLY (FTC)
LED2	POWER SUPPLY (WIRED REMOTE CONTROLLER)
LED3	TRANSMISSION(FTC-OUTDOOR UNIT)
LED4, 5	NOT IN USE
FUSE	FUSE(3.15A/250V)
SW1	SWITCH *See Table 3, 4 and 6.
SW2	SWITCH *See Table 5.
SW3	SWITCH(4-20mA/1-5V/0-10V switch) *See Table 3.
SW6	VARIABLE RESISTOR
ZNR01, 02	VARISTOR
DSA	SURGE ABSORBER
X1 ~X7	RELAY
TH1	ACTUAL FLOW WATER TEMP. THERMISTOR (Water piping)
TH2	(OC/1.5KΩ, 25C/5.2KΩ DETECT)
	PIPE TEMP. THERMISTOR/LIQUID (Refrigerant piping)
	(0C/1.5KΩ, 25C/5.2KΩ DETECT)

3-5. PCB diagram(Test point)

(1) PAC-IF011B-E, PAC-IF010-E

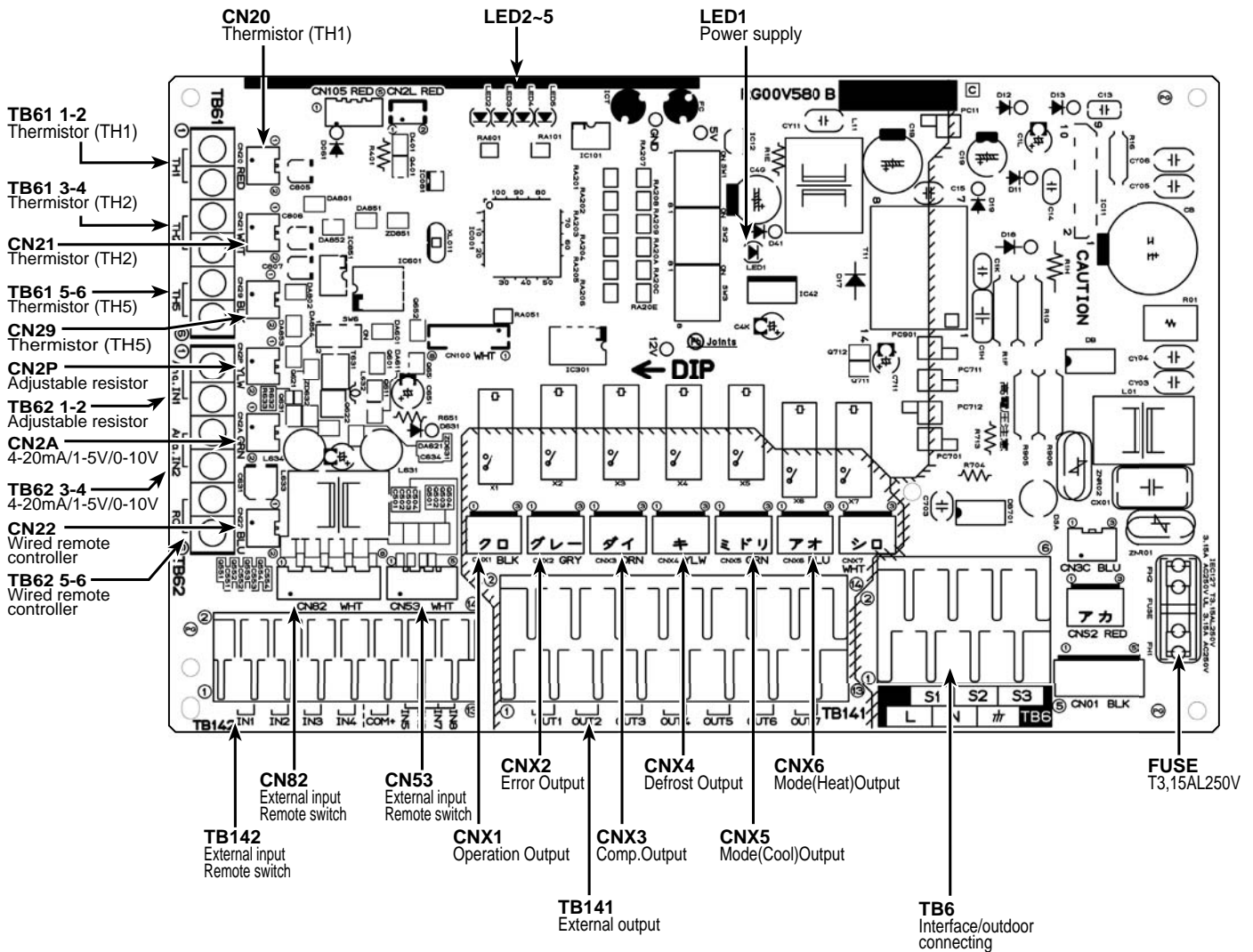

	PAC-IF011B-E	PAC-IF010-E
TB6	○	○
TB141	○	—
TB142	○	○
TB61	○	○
TB62	○	○
CNX1~CNX6	—	○
CN20	○	○
CN21	○	○
CN29	○	○
CN2P	○	○
CN2A	○	○
CN22	○	○

○ : mounting
 — : unmounting

(2) PAC-IF021B-E(FTC), PAC-IF020-E

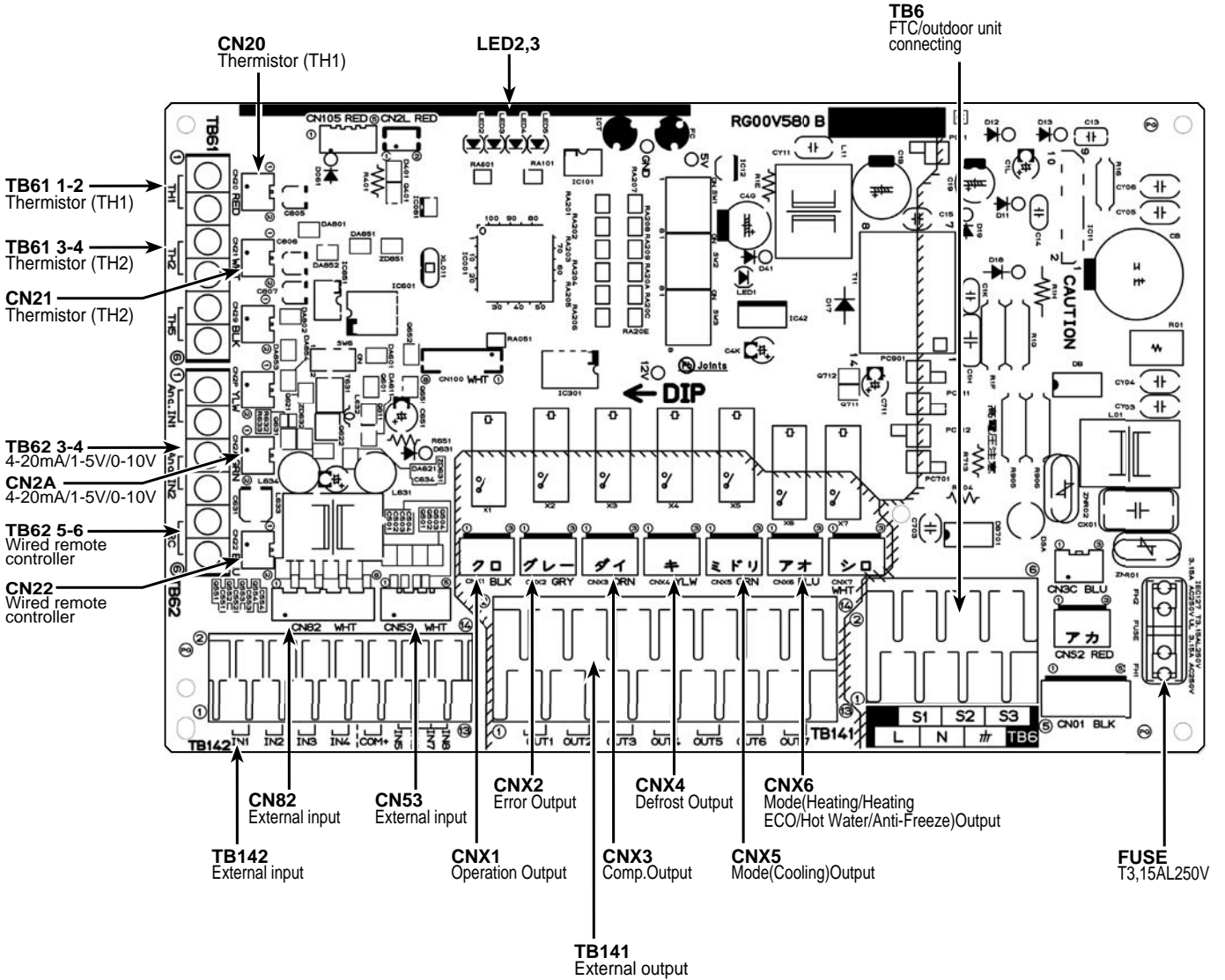

	PAC-IF021B-E	PAC-IF020-E
TB6	○	○
TB141	○	—
TB142	○	○
TB61	○	○
TB62	○	○
CNX1~CNX6	—	○
CN20	○	○
CN21	○	○
CN29	○	○
CN2P	○	○
CN2A	○	○
CN22	○	○

○ : mounting
 — : unmounting

3-6. Specification of connectors

Please connect wiring with either of the terminal bed or the connector.
Parts on the PCB are different depending on the model.

PCB ONLY		Cased	
PAC-IF010-E PAC-IF020-E		PAC-IF011B-E PAC-IF021B-E	
Parts on PCB		Parts on PCB	
TERMINAL BED	CONNECTOR	TERMINAL BED	CONNECTOR
TB6		TB6	
	CNX1 CNX2 CNX3 CNX4 CNX5 CNX6	TB141	
TB142	CN82 CN53	TB142	
TB61	CN20 CN21 CN29	TB61	CN20 CN21 CN29
TB62	CN2P CN2A CN22	TB62	CN2P CN2A CN22

The following terminal bed and the connector is the same signals, meaning.

TB6

TERMINAL BED	CONNECTOR	
	NAME	PIN No.
TB6-L	—	—
TB6-N	—	—
TB6-PE	—	—
TB6-S1	—	—
TB6-S2	—	—
TB6-S3	—	—

Specification of connectors (Manufacture: J.S.T. Mfg. Co., Ltd.)

CONNECTOR NAME	HOUSING
CNX1 ~ 6	VHR-3N
CN82	XAP-08V-1
CN53	XAP-05V-1
CN20,21,29,2P,2A,22	XAP-02V-1

Contact pin : According to the wiring size select the correct contact pin by yourself.

TB141, TB142, TB61

TERMINAL BED	CONNECTOR	
	NAME	PIN No.
TB141-1,2	CNX1	1,3pin
TB141-3,4	CNX2	1,3pin
TB141-5,6	CNX3	1,3pin
TB141-7,8	CNX4	1,3pin
TB141-9,10	CNX5	1,3pin
TB141-11,12	CNX6	1,3pin
TB142-1	CN82	1pin
TB142-2	CN82	2pin
TB142-3	CN82	3pin
TB142-4	CN82	4pin
TB142-5	CN82	5pin
TB142-6	CN82	6pin
TB142-7	CN82	7pin
TB142-8	CN82	8pin
TB142-9	CN53	5pin
TB142-10	CN53	5pin
TB142-11	CN53	1pin
TB142-12	CN53	2pin
TB142-13	CN53	3pin
TB142-14	CN53	4pin
TB61-1,2	CN20	1,2pin
TB61-3,4	CN21	1,2pin
TB61-5,6	CN29	1,2pin
TB62-1,2	CN2P	1,2pin
TB62-3,4	CN2A	1,2pin
TB62-5,6	CN22	1,2pin

CONTENTS

1. System outline	24
2. System structure.....	24
3. Power supply	28
4. Connecting thermistor.....	30
5. Interface controller switch setting	31
6. Input specifications	32
7. Output specifications	33
8. LED display detail.....	34
9. Maintenance information	35
10. Central control	52
11. Outlines and dimensions	53
12. Troubleshooting	54

Notes on system controller side in I/F connection system

(1) Please do not transmit "STEP 0" during defrost operation.

Defrost operation might be interrupted, and frost remain.

(Please demand the planned capacity step even when the system controller receives defrost signal from the heat pump (outdoor unit)).

(2) Please do not transmit "STEP 0" when the outdoor unit(H/P) is abnormal.

Abnormal detection data is reset, and an Abnormal point cannot be confirmed.

1. System outline

With PAC-IF011B-E, local units can be connected with the outdoor units manufactured by MITSUBISHI ELECTRIC. The commands, such as Remote switch, Varistor, 4-20mA/1-5V/0-10V and etc., allow the inverter outdoor unit to operate, to stop and to switch capacity. By outputting the operation state, the interface can be connected with the local unit. Also, the interface can be connected with wired remote controller for maintenance so that the maintenance information is obtained. Only the outdoor units with self-controlled S/W are connectable.

2. System structure

System structure(1)

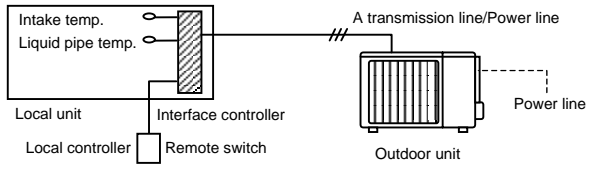
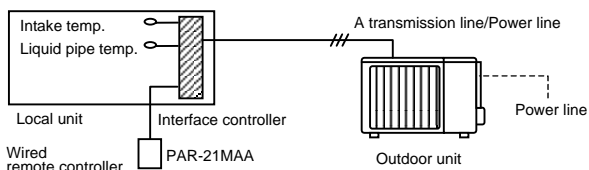
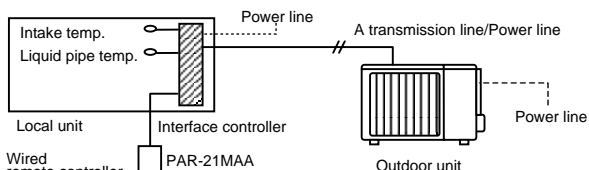
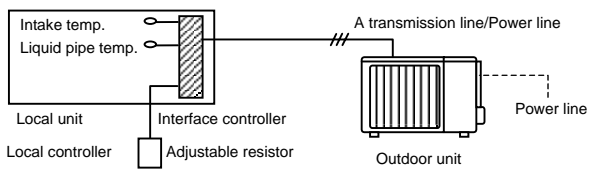
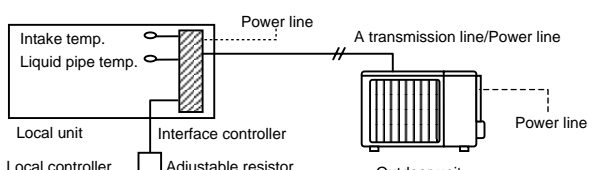
Outdoor unit capacity switch	System diagram	Power supply specifications
<p>Remote switch</p> <p>Capacity switch of outdoor unit according to the remote switch</p> <p>When auto stop being set, the difference between room temperature and set temperature of interface, and the pipe temperature switch the capacity of outdoor unit automatically.</p>		<p>Power supplied from outdoor unit</p> <p>Power supply for interface controller is supplied from the outdoor unit. Refer to 3.1.</p>
<p>Wired remote controller (Auto step mode only)</p> <p>The difference between room temperature and set temperature of wired remote controller, and the pipe temperature switch the capacity of outdoor unit automatically.</p>		<p>Power supplied from outdoor unit</p> <p>Power supply for interface controller is supplied from the outdoor unit. Refer to 3.1.</p>
<p>As with the remote controller for air conditioner, the interface performs ON/OFF operation, and changes operation mode (cooling, heating, fan) and set temperature.</p>		<p>Separate interface/outdoor unit power supplies</p> <p>Power supply for interface controller and power supply for outdoor unit are supplied from the different source. (Common power source for local unit and interface controller) Refer to 3.2.</p>
<p>Adjustable resistor(0-10kΩ)</p> <p>Capacity switch of outdoor unit according to the adjustable resistor</p>		<p>Power supplied from outdoor unit</p> <p>Power supply for interface controller is supplied from the outdoor unit. Refer to 3.1.</p>
		<p>Separate interface/outdoor unit power supplies</p> <p>Power supply for interface controller and power supply for outdoor unit are supplied from the different source. (Common power source for local unit and interface controller) Refer to 3.2.</p>

Note:

• **REMOTE SWITCH Type A (4bit - 8 setting) / Type B (1bit -1 setting)**

TB142 10-11 (COM-IN5)	TB142 10-12 (COM-IN6)	TB142 10-13 (COM-IN7)	TB142 10-14 (COM-IN8)	Step for capacity setting *				Remark		
				TypeA		TypeB				
OFF	OFF	OFF	OFF	[OFF]	OFF	0%	[OFF]	OFF	0%	Fixed capacity (Hz fixed) mode
ON	OFF	OFF	OFF	[ON]	Step1	10%	[ON]	Step1	10%	
OFF	ON	OFF	OFF		Step2	20%		Step4	50%	
ON	ON	OFF	OFF		Step3	30%		↑	↑	
OFF	OFF	ON	OFF		Step4	50%		Step7	100%	
ON	OFF	ON	OFF		Step5	70%		↑	↑	
OFF	ON	ON	OFF		Step6	80%		↑	↑	
ON	ON	ON	OFF		Step7	100%		↑	↑	
OFF	OFF	OFF	ON		Auto step			Auto step		Auto step mode

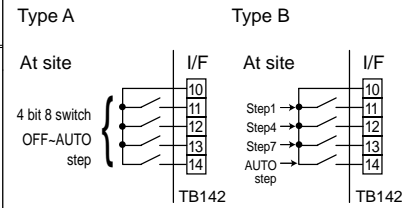

* The actual capacity will be slightly different from the numerical data in this table depending on conditions such as the ambient temperature.

Attachment of sensor	Interface controller switch setting	Interface controller specifications		Other functions/setting Maintenance	Connection with BMS/MELANS
		Input and wiring	Output and wiring		
Refer to 4. Pipe-thermistor/ 2-phase might be necessary depending on the type of the outdoor unit.	2 patterns can be set. (Refer to NOTE 1.) Type A SW1-1:OFF SW1-2:OFF SW1-3:OFF SW6-1:OFF SW6-2:OFF	Type A OFF/Step1/Step2/ ...Step7/Auto step Type B OFF/Step1/Step4/ Step7/Auto step Refer to 6 for details.	Refer to 7.	Refer to 8, 9.	Not available
Refer to 4. Pipe-thermistor/ 2-phase might be necessary depending on the type of the outdoor unit.	Type B SW1-1:ON SW1-2:OFF SW1-3:OFF SW6-1:OFF SW6-2:OFF Other switches are to be set according to the site. Refer to 5 for details.		Refer to 7.	Refer to 8, 9.	Not available
Refer to 4. Pipe-thermistor/ 2-phase might be necessary depending on the type of the outdoor unit.	SW1-1:OFF SW1-2:ON SW1-3:ON SW6-1:OFF SW6-2:OFF Other switches are to be set according to the site. Refer to 5 for details.	TB62 Connect the wired remote controller wire to No.5-6 Wiring Wire NO.xsize(mm ²) 2×0.3(Non-polar) Max. 500m Circuit rating DC12V The figure is NOT always against the ground. Only the operation with remote controller is valid. (External signal is invalid)	Refer to 7.	Refer to 8, 9.	Available Refer to 10. Connect adaptor to outdoor unit. M-NET converter PAC-SF80MA-E A-Control sub Interface PAC-SK82SI-E
Refer to 4. Pipe-thermistor/ 2-phase might be necessary depending on the type of the outdoor unit.			Refer to 7.	Refer to 8, 9.	Available Refer to 10. Connect adaptor to outdoor unit. M-NET converter PAC-SF80MA-E A-Control sub Interface PAC-SK82SI-E
Refer to 4. Pipe-thermistor/ 2-phase might be necessary depending on the type of the outdoor unit.	SW1-1:OFF SW1-2:OFF SW1-3:ON SW6-1:OFF SW6-2:OFF	Refer to 6.	Refer to 7.	Refer to 8, 9.	Not available
Refer to 4. Pipe-thermistor/ 2-phase might be necessary depending on the type of the outdoor unit.	Other switches are to be set according to the site. Refer to 5 for details.	Refer to 6.	Refer to 7.	Refer to 8, 9.	Not available

System structure(2)

Outdoor unit capacity switch	System diagram	Power supply specifications
<p>4-20mA</p> <p>Capacity switch of outdoor unit according to the signal of 4-20mA</p>		<p>Power supplied from outdoor unit</p> <p>Power supply for interface controller is supplied from the outdoor unit. Refer to 3.1.</p>
		<p>Separate interface/outdoor unit power supplies</p> <p>Power supply for interface controller and power supply for outdoor unit are supplied from the different source. (Common power source for local unit and interface controller) Refer to 3.2.</p>
<p>1-5V</p> <p>Capacity switch of outdoor unit according to the signal of 1-5V</p>		<p>Power supplied from outdoor unit</p> <p>Power supply for interface controller is supplied from the outdoor unit. Refer to 3.1.</p>
		<p>Separate interface/outdoor unit power supplies</p> <p>Power supply for interface controller and power supply for outdoor unit are supplied from the different source. (Common power source for local unit and interface controller) Refer to 3.2.</p>
<p>0-10V</p> <p>Capacity switch of outdoor unit according to the signal of 0-10V</p>		<p>Power supplied from outdoor unit</p> <p>Power supply for interface controller is supplied from the outdoor unit. Refer to 3.1.</p>
		<p>Separate interface/outdoor unit power supplies</p> <p>Power supply for interface controller and power supply for outdoor unit are supplied from the different source. (Common power source for local unit and interface controller) Refer to 3.2.</p>

Attachment of sensor	Interface controller switch setting	Interface controller specifications		Other functions/setting Maintenance	Connection with BMS/MELANS
		Input and wiring	Output and wiring		
Refer to 4. Pipe-thermistor/ 2-phase might be necessary depending on the type of the outdoor unit.	SW1-1:ON SW1-2:ON SW1-3:OFF SW6-1:ON SW6-2:ON Other switches are to be set according to the site. Refer to 5 for details.	Refer to 6.	Refer to 7.	Refer to 8, 9.	Not available
Refer to 4. Pipe-thermistor/ 2-phase might be necessary depending on the type of the outdoor unit.		Refer to 6.	Refer to 7.	Refer to 8, 9.	Not available
Refer to 4. Pipe-thermistor/ 2-phase might be necessary depending on the type of the outdoor unit.	SW1-1:ON SW1-2:ON SW1-3:OFF SW6-1:OFF SW6-2:ON Other switches are to be set according to the site. Refer to 5 for details.	Refer to 6.	Refer to 7.	Refer to 8, 9.	Not available
Refer to 4. Pipe-thermistor/ 2-phase might be necessary depending on the type of the outdoor unit.		Refer to 6.	Refer to 7.	Refer to 8, 9.	Not available
Refer to 4. Pipe-thermistor/ 2-phase might be necessary depending on the type of the outdoor unit.	SW1-1:OFF SW1-2:OFF SW1-3:ON SW6-1:OFF SW6-2:OFF Other switches are to be set according to the site. Refer to 5 for details.	Refer to 6.	Refer to 7.	Refer to 8, 9.	Not available
Refer to 4. Pipe-thermistor/ 2-phase might be necessary depending on the type of the outdoor unit.		Refer to 6.	Refer to 7.	Refer to 8, 9.	Not available

3. Power Supply

Interface controller is applicable to both methods of interface unit power supplied from outdoor unit, and of separate interface unit/outdoor unit power supplies. Choose one according to the site.

(Photo. 3-1)

- Ⓐ Inlet for control cable
- Ⓑ Inlet for power
- Ⓒ Clamp
- Ⓓ Interface / Outdoor unit connecting terminals
- Ⓔ Earth terminal

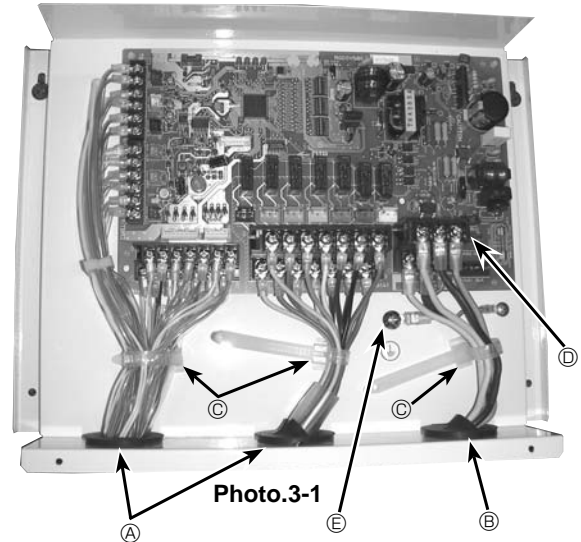

3.1. Interface unit power supplied from outdoor unit (Photo 3-2)

The following connection patterns are available.

The outdoor unit power supply patterns vary on models.

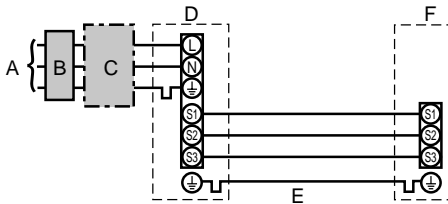

- A Outdoor unit power supply
- B Earth leakage breaker
- C Wiring circuit breaker or isolating switch
- D Outdoor unit
- E Interface unit/outdoor unit connecting cables
- F Interface unit

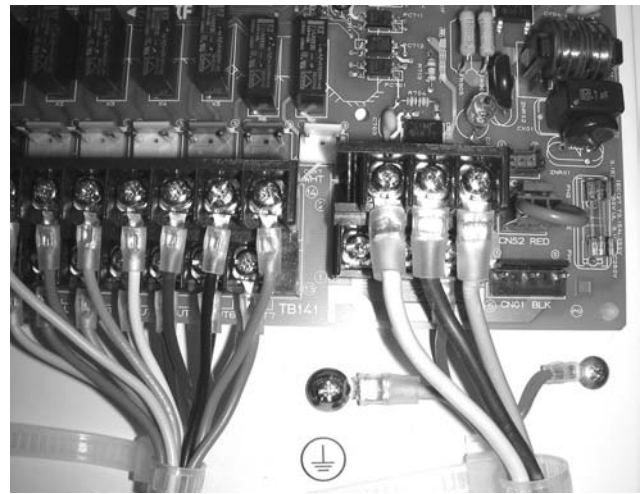

Photo.3-2

Interface unit model		PAC-IF011B-E	
Wiring Wire No.x size (mm ²)	Interface unit-Outdoor unit	*1	3× 1.5 (polar)
	Interface unit-Outdoor unit earth	*1	1 × Min.1.5
Circuit rating	Interface unit-Outdoor unit S1-S2	*2	AC 230 V
	Interface unit-Outdoor unit S2-S3	*2	DC24 V

*1. Max. 80 m

*2. The figures are NOT always against the ground.

S3 terminal has DC 24 V against S2 terminal. However between S3 and S1, these terminals are not electrically insulated by the transformer or other device.

- Notes:**
1. Wiring size must comply with the applicable local and national code.
 2. Power supply cables and interface unit/outdoor unit connecting cables shall not be lighter than polychloroprene sheathed flexible cable. (Design 60245 IEC 57)
 3. Install an earth longer than other cables.

3.2. Separate interface unit/outdoor unit power supplies

The following connection patterns are available.

The outdoor unit power supply patterns vary on models.

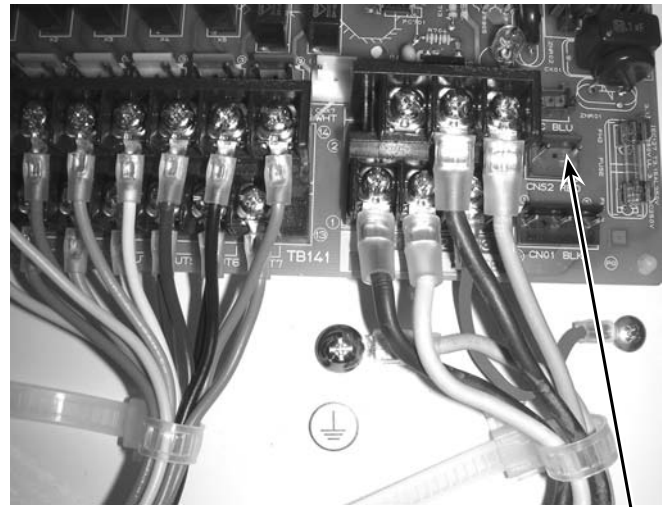
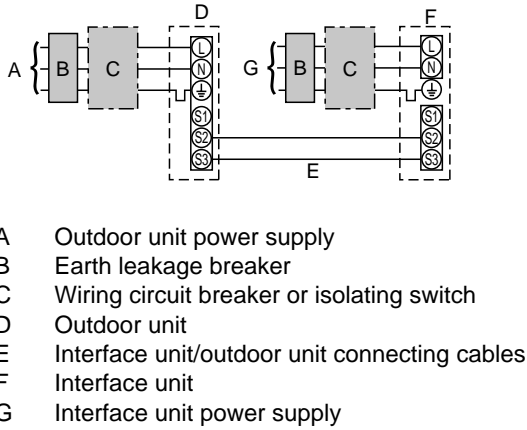

Photo. 3-3

CNS2

If the interface and outdoor units have separate power supplies, refer to the table below.

	Separate power supply specifications								
Interface unit controller connector (CNS2) connection change	Disconnected								
Outdoor unit DIP switch settings (when using separate interface unit/outdoor unit power supplies only)	<table border="1"> <tr> <td>ON</td> <td></td> <td></td> <td>3</td> </tr> <tr> <td>OFF</td> <td>1</td> <td>2</td> <td></td> </tr> </table> (SW8) Set the SW8-3 to ON.	ON			3	OFF	1	2	
ON			3						
OFF	1	2							

Interface unit model	PAC-IF011B-E	
Interface unit power supply	~ / N (Single Phase), 50 Hz, 230 V	
Interface unit input capacity	*1	16 A
Main switch (Breaker)		
Wiring Wire No. x size (mm ²)	Interface unit power supply & earth	3 × Min. 1.5
	Interface unit-Outdoor unit	*2 2 × Min. 0.3
	Interface unit-Outdoor unit earth	–
Circuit rating	Interface unit L-N	*3 AC230V
	Interface unit-Outdoor unit S1-S2	*3 –
	Interface unit-Outdoor unit S2-S3	*3 DC24V

*1. A breaker with at least 3.0mm contact separation in each pole shall be provided. Use earth leakage breaker (NV).

*2. Max. 120 m

*3. The figures are NOT always against the ground.

- Notes:**
1. Wiring size must comply with the applicable local and national code.
 2. Power supply cables and interface unit/outdoor unit connecting cables shall not be lighter than polychloroprene sheathed flexible cable. (Design 60245 IEC 57)
 3. Install an earth longer than other cables.

4. Connecting thermistor

4.1 Connecting thermistor cable

Connect the thermistor for the interface controller.
When the thermistor cables are too long, cut it to the appropriate length.
Do not bind it in the interface unit.

1. Target temp. thermistor (TH1)
Connect the thermistor for the target temp. to 1 and 2 on the terminal block (TB61) on the interface controller.
2. Pipe temp. thermistor / Liquid (TH2)
Connect the thermistor for the pipe temp. to 3 and 4 on the terminal block (TB61) on the interface controller.
3. Pipe temp. thermistor / 2-phase (TH5).
Connect the thermistor for the 2-phase temp. to 5 and 6 on the terminal block (TB61) on the interface controller.
Set the DIP switch 2-6 to OFF of the interface controller.

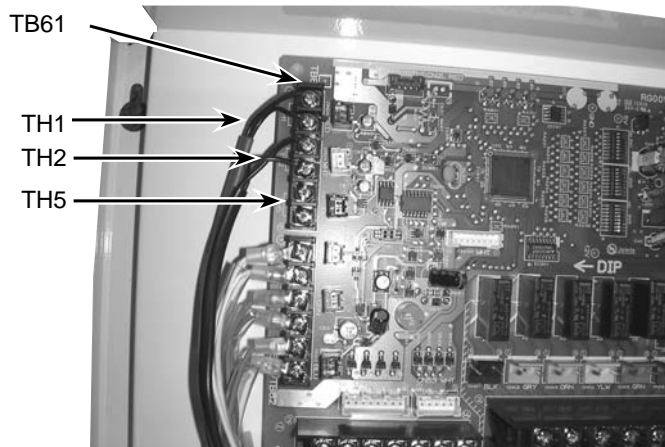

Photo. 4-1

Caution:

Do not route the thermistor cables together with power cables.
The sensor part of the thermistor should be installed where user must not touch.
(It is separated by the supplementary insulation from where user may touch.)

4.2 Thermistor position

< Target temp. thermistor (TH1) > (Used only in *auto step mode (Only for Air to Air applications))

1. Put thermistor(TH1) where average intake temperature for heat exchanger can be detected.
2. It is better to put thermistor(TH1) where radiant heat from heat exchanger can be avoided.
To use this interface for manual step control, put a fixed resistor of 4~10kΩ instead of thermistor.(TH1 on the terminal block TB61)
* Auto step mode: In this mode, the capacity step of the outdoor unit is controlled automatically to let the target (intake) temperature reach the set temperature.(Only for air to air application)

< Liquid pipe thermistor (TH2) >

1. Put thermistor(TH2) where liquid refrigerant pipe temperature can be detected.
2. It is better to protect the thermistor(TH2) with heat insulating materials not to be affected by the ambient temperature, etc.
3. In case that the refrigerant is distributed by distributor, put thermistor(TH2) before the distributor.

< 2 phase pipe (condensing/evaporating) thermistor (TH5) >

*Only for Air to Air application (Refer to page.4)

*Only in AUTO STEP mode of the I/F (Refer to page.4)

1. 2 phase pipe thermistor must be located where the 2 phase (condensing / evaporating) temperature of HEX can be measured.
2. Preferably, it should be insulated to avoid any influences by the ambient air temperature and so.
3. It must be located where it does NOT measure hot gas/subcool liquid temperature in heating mode.
4. If HEX is divided into several paths, 2 phase pipe thermistor should be put on the upper path.(Liquid refrigerant tends to stay in the lower path when HEX works as a condenser, and the improper temperature may possibly be picked up.)
5. 2 phase thermistor should be located in the middle of the path. If it is impossible to put it in the middle, it should be put a bit inlet side of condenser. Do NOT move it too much to the inlet side, however, as it may possibly pick up hot gas temperature. (Never put it on the outlet side of condenser as it may pick up subcool liquid temperature.)

<Thermistor Characteristic graph>

Thermistor for lower temperature

- Target temperature thermistor (TH1)
- Pipe temperature thermistor/liquid (TH2)
- Pipe temperature thermistor / 2-phase (TH5)

Thermistor R0 =15kΩ ± 3%

Fixed number of B =3480 ± 2%

$$R_t = 15 \exp \left\{ 3480 \left(\frac{1}{273+t} - \frac{1}{273} \right) \right\}$$

0°C	15kΩ
10°C	9.6kΩ
20°C	6.3kΩ
25°C	5.4kΩ
30°C	4.3kΩ
40°C	3.0kΩ

< Thermistor for lower temperature >

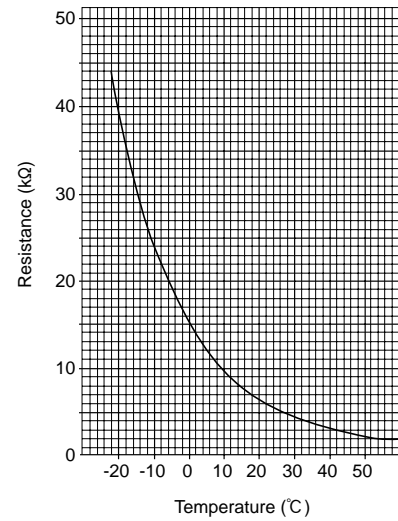

5. Interface controller switch setting

Set the switches following the system specifications below.

Switch1. Switch6 : Input selection of inverter capacity setting

Input	SW 1-1	SW 1-2	SW 1-3	SW 6-1	SW 6-2	Step for capacity setting
REMOTE SWITCH Type A (4bit-8 setting)	OFF	OFF	OFF	OFF	OFF	OFF/Step1/Step2/.../Step7/Auto step
REMOTE SWITCH Type B (1bit-1 setting)	ON	OFF	OFF	OFF	OFF	OFF/Step1/Step4/Step7/Auto step
4-20mA	ON	ON	OFF	ON	ON	OFF/Step1/Step2/.../Step7
1-5V	ON	ON	OFF	OFF	ON	OFF/Step1/Step2/.../Step7
0-10V	OFF	OFF	ON	OFF	OFF	OFF/Step1/Step2/.../Step7
0-10kΩ	ON	OFF	ON	OFF	OFF	OFF/Step1/Step2/.../Step7/Auto step
No input (AUTO mode)	OFF	ON	ON	OFF	OFF	Only Auto step mode

SW1-4~8 : OFF fixed (Initial setting)

• SW2-1/2-2 : Fixed operation mode

SW2-1	SW2-2	Details
OFF	OFF	Not FIX (Depending on Remote controller setting)
ON	OFF	[Cooling]FIX
OFF	ON	[Heating]FIX
ON	ON	External input(Depending on TB142-3,4)

• SW2-3/2-4/2-5 : Fixed set temperature [For Auto step mode only]

SW2-3	SW2-4	SW2-5	Details
OFF	OFF	OFF	Not fixed (Remote controller setting)
ON	OFF	OFF	Cooling 19 °C /Heating 17 °C FIX
OFF	ON	OFF	20 °C FIX
ON	ON	OFF	22 °C FIX
OFF	OFF	ON	24 °C FIX
ON	OFF	ON	26 °C FIX
OFF	ON	ON	28 °C FIX
ON	ON	ON	Cooling 30 °C / Heating 28 °C FIX

Set switches in case of auto step mode.

SW2-6 : Setting of TH5

When TH5 (2-phase pipe temp. thermistor) is connected, it is necessary to set the Dip SW2-6 of the interface controller.

SW2-6	Details
OFF	Connect TH5
ON	Not connect TH5 (Initial setting)

SW2-7, 8 : OFF fixed (Initial setting)

SW3 : LED2~5 display setting (Refer to 8.)

6. Input specifications

Demand control is available by external input.

It is possible to set the outdoor unit's power consumption by setting the switch of the interface controller.

- REMOTE SWITCH Type A (4bit - 8 setting) / Type B (1bit -1 setting)

TB142 10-11 (COM-IN5)	TB142 10-12 (COM-IN6)	TB142 10-13 (COM-IN7)	TB142 10-14 (COM-IN8)	Step for capacity setting						Remark
				TypeA			TypeB			
OFF	OFF	OFF	OFF	[OFF]	OFF	0%	[OFF]	OFF	0%	OFF
ON	OFF	OFF	OFF	[ON]	Step1	10%	[ON]	Step1	10%	Fixed capacity (Hz fixed) mode
OFF	ON	OFF	OFF		Step2	20%		Step4	50%	
ON	ON	OFF	OFF		Step3	30%		↑	↑	
OFF	OFF	ON	OFF		Step4	50%		Step7	100%	
ON	OFF	ON	OFF		Step5	70%		↑	↑	
OFF	ON	ON	OFF		Step6	80%		↑	↑	
ON	ON	ON	OFF		Step7	100%		↑	↑	
OFF	OFF	OFF	ON	Auto step			Auto step		Auto step mode	

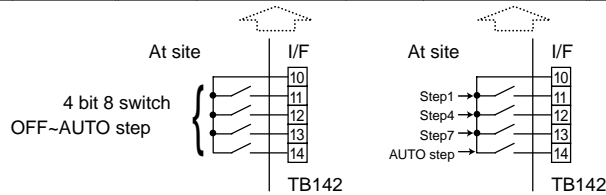

Demand control is available by connecting remote switches with terminal No.10 - 14.

Make sure to use the non-voltage switch (for the remote switch).

Remote switch cable length : Maximum 10m

Remote switch : Minimum applicable load DC12V, 1mA

- 4-20mA / 1-5V / 0-10V / 0-10kΩ

① Use 4-20mA / 1-5V / 0-10V

Connect the transmission cables to No. 3 and 4 on the terminal block (TB62).

No. 3 on the terminal block(TB62) : Plus side

No. 4 on the terminal block(TB62) : Minus side (Reference side)

② Use adjustable resistor (0-10kΩ)

Connect the transmission cables to No. 1 and 2 on the terminal block (TB62).

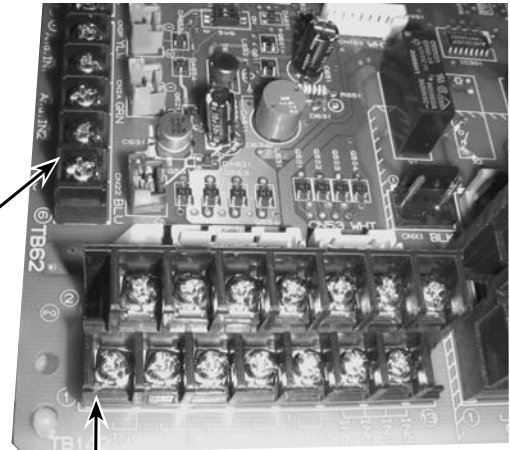

TB142

Photo. 6-1

Adjust-able resistor (0-10kΩ)	4-20mA	1-5V	0-10V	Step for capacity setting		Remark
0~100Ω	4~5mA	0~1.25V	0~0.63V	OFF	0%	Stop
510Ω	7mA	1.75V	1.88V	Step1	10%	Fixed capacity (Hz fixed) mode
1kΩ	9mA	2.25V	3.13V	Step2	20%	
2kΩ	11mA	2.75V	4.38V	Step3	30%	
3.3kΩ	13mA	3.25V	5.63V	Step4	50%	
4.3kΩ	15mA	3.75V	6.88V	Step5	70%	
5.6kΩ	17mA	4.25V	8.13V	Step6	80%	
7.5kΩ	19~20mA	4.75~5V	9.38~10V	Step7	100%	
10kΩ	—	—	—	Auto step		Auto step mode
OPEN(12kΩ~)	—	—	—	OFF	0%	Stop

*The values of the above table show the mid-point of each step range.

tolerance : 0-10kΩ : ±5%

4-20mA : ±0.4mA

1-5V : ±0.1V

0-10V : ±0.2V

Cable length : Maximum 10m

• **External function setting**

This function is to set operation mode or to stop compressor by the external signal.

TB142	Item	OFF	ON	Remark
1-2 (IN1)	Forced Comp. OFF	Normal	Forced Comp. OFF	
3-4 (IN2)Item	Fixed operation mode	Cooling	Heating	Available when SW2-1 and SW2-2 are ON

Cable length : Maximum 10m

Remote switch : Minimum applicable load DC12V, 1mA

Caution:

The external input signals are separated by basic insulation from power supply for the unit.

The external input signals should be separated by supplementary insulation from where user may touch in case that it is installed where user may touch.

Connect the terminals by using the ring terminals and also insulate the cables of adjoining terminals when wiring to terminal block.

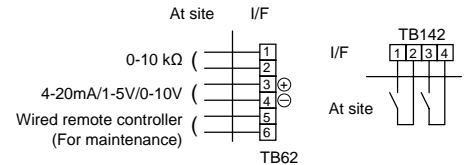

7. Output specifications

Connecting External Output

The signal in the following states can be output.

TB141		Item	OFF	ON
1-2 (OUT1)	X1	Operation Output	OFF	ON
3-4 (OUT2)	X2	Error Output	Normal	Error
5-6 (OUT3)	X3	Comp. Output	OFF(Comp. OFF)	ON (Comp. ON)
7-8 (OUT4)	X4	Defrost Output	OFF	ON (Defrosting)
9-10 (OUT5)	X5	Mode(Cool)Output	OFF	ON (Cooling)
11-12 (OUT6)	X6	Mode(Heat)Output	OFF	ON (Heating)
13-14 (OUT7)	-	-	-	-

Cable length : Maximum 50m

Output specification : Non-voltage switch 1A or less , 240V AC

*Connect the surge absorber according to the load at site.

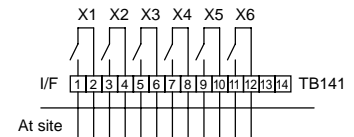

Note :

External output signals are separated by basic insulation from other circuit of interface.

Caution :

When 2 or more external outputs are used, the power supply on the output side should be the same.

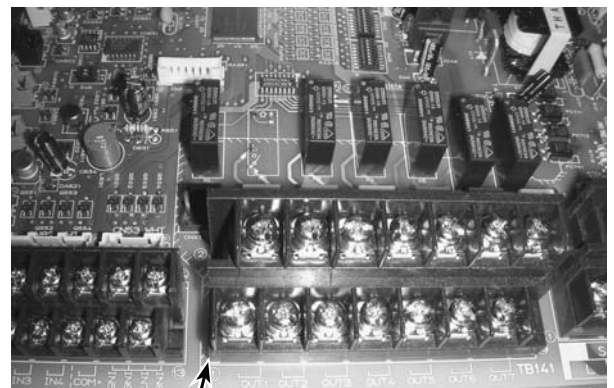

Photo.3-6

Wiring specification of External output / External input Locally supplied parts

Item	Name	Model and specifications
External output function	External output signal wire	Use sheathed vinyl coated cord or cable. Wire type : CV, CVS or equivalent. Wire size : Stranded wire 0.5mm ² to 1.25mm ² Solid wire: φ0.65mm to φ1.2mm
	Display lamp, etc.	Non-voltage Contact AC220-240V (DC30V), 1A or less
External input function	External input signal wire	Use sheathed vinyl coated cord or cable. Wire type : CV, CVS or equivalent. Wire size : Stranded wire 0.5mm ² to 1.25mm ² Solid wire : φ0.65mm to φ1.2mm
	Switch	Non-voltage "a" contact

8. LED Display detail

Setting SW3 allows to switch the LED display.

LED1 : Power supply

LED2~4 : Setting SW3 switches the display

SW3-1	SW3-2	SW3-3	Display detail
OFF	OFF	OFF	A
ON	OFF	OFF	B
OFF	ON	OFF	C
ON	ON	OFF	D
OFF	OFF	ON	E
ON	OFF	ON	F
OFF	ON	ON	G

[Display detail A]

LED	Details of LED display	LED display	
LED2	Power supply for remote controller	OFF : Power is not supplied.	ON : Power is supplied.
LED3	Communication link between interface and outdoor units	OFF : No link	Blink : Linked
LED4	N/A	—	
LED5	N/A	—	

[Display detail B]

LED	Function	LED display and condition							
LED2	Thermo	OFF				ON			
LED3	Comp.	OFF				ON			
LED4	Control status	OFF	Normal	ON	Hot adjust	OFF	Defrosting	ON	Demand Comp. OFF
LED5		OFF		OFF		ON			

[Display detail C]

		0% OFF	10% Fix	20% Fix	30% Fix	40% Fix	50% Fix	60% Fix	70% Fix	80% Fix	90% Fix	100% Fix	Auto
LED2	Capacity request status (Output)	OFF	ON	OFF	ON	OFF	ON	OFF	ON	OFF	ON	OFF	ON
LED3		OFF	OFF	ON	ON	OFF	OFF	ON	ON	OFF	OFF	ON	ON
LED4		OFF	OFF	OFF	OFF	ON	ON	ON	ON	OFF	OFF	OFF	OFF
LED5		OFF	OFF	OFF	OFF	OFF	OFF	OFF	OFF	OFF	ON	ON	ON

* Displays the output status(the request which the I/F sends to the outdoor unit)

[Display detail D]

		0% OFF	10% Fix	20% Fix	30% Fix	40% Fix	50% Fix	60% Fix	70% Fix	80% Fix	90% Fix	100% Fix	Auto
LED2	Capacity request status (Input)	OFF	ON	OFF	ON	OFF	ON	OFF	ON	OFF	ON	OFF	ON
LED3		OFF	OFF	ON	ON	OFF	OFF	ON	ON	OFF	OFF	ON	ON
LED4		OFF	OFF	OFF	OFF	ON	ON	ON	ON	OFF	OFF	OFF	OFF
LED5		OFF	OFF	OFF	OFF	OFF	OFF	OFF	OFF	OFF	ON	ON	ON

* Displays the input state(the request which this I/F receives)

[Display detail E]

LED	Input condition	LED display		Details
LED2	TB142 1-2(IN1)Input	OFF	ON	Forced Comp. OFF (ON:Forced Comp. OFF)
LED3	TB142 3-4(IN2)Input	OFF	ON	Fixed operation mode (OFF=Cooling/ON=Heating)
LED4	N/A	—		—
LED5	N/A	—		—

[Display detail F]

LED	Output condition	LED display		Details
LED2	TB141 1-2(OUT1) Output	OFF	ON	Operation output
LED3	TB141 3-4(OUT2) Output	OFF	ON	Error output
LED4	TB141 5-6(OUT3) Output	OFF	ON	Comp. output
LED5	TB141 7-8(OUT4) Output	OFF	ON	Defrost output

[Display detail G]

LED	Output condition	LED display		Details
LED2	TB141 9-10(OUT5) Output	OFF	ON	Cooling output
LED3	TB141 11-12(OUT6) Output	OFF	ON	Heating output
LED4	N/A	—		—
LED5	N/A	—		—

9. Maintenance information

Connecting wired remote controller(PAR-21MAA) enables to display the error information.

Note: In case of using for ATW, the refrigerant leakage deflection function of the outdoor unit is not available.

9.1. Connecting wired remote controller

Turn off the power supply.

TB62 : Connect the wired remote controller wire to No. 5, 6(non-polar).

Note : Be sure to turn off the power supply before disconnecting the wired remote controller wire. Otherwise it may cause trouble or to activate abnormality alarm.

9.2. Wired remote controller display

• Operation buttons

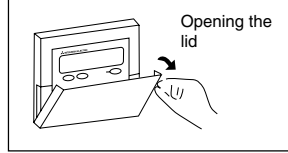
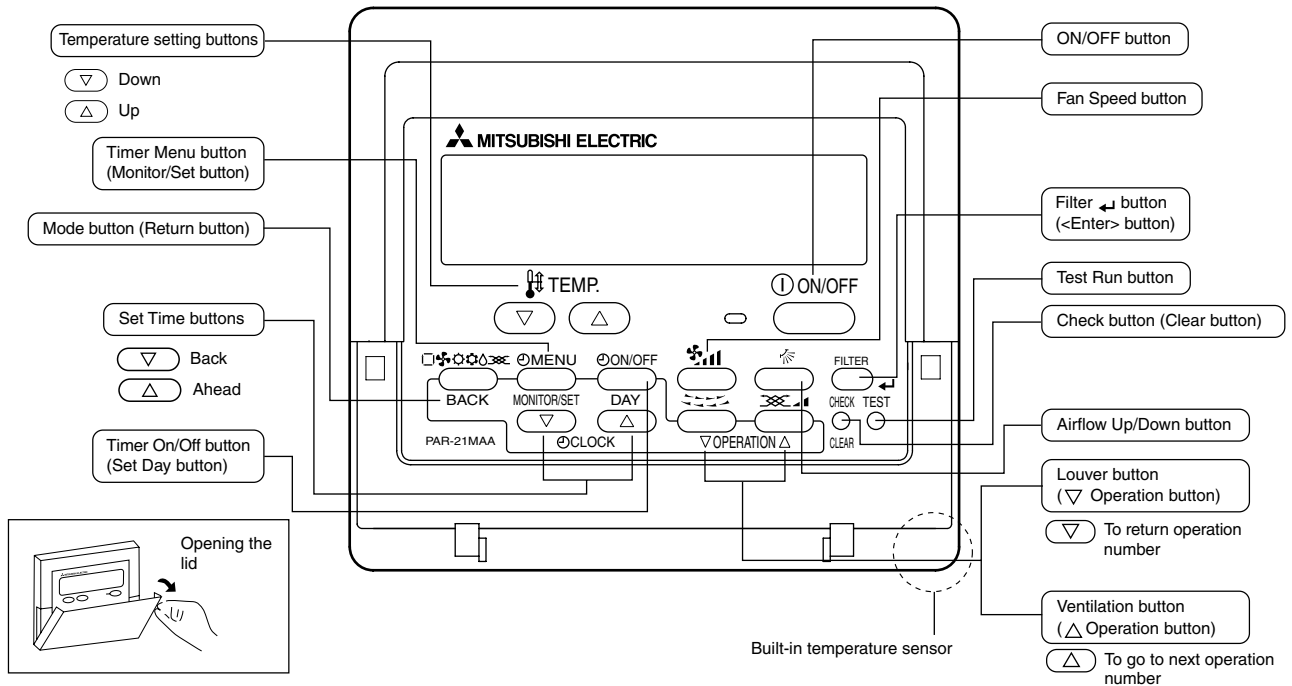

• Display

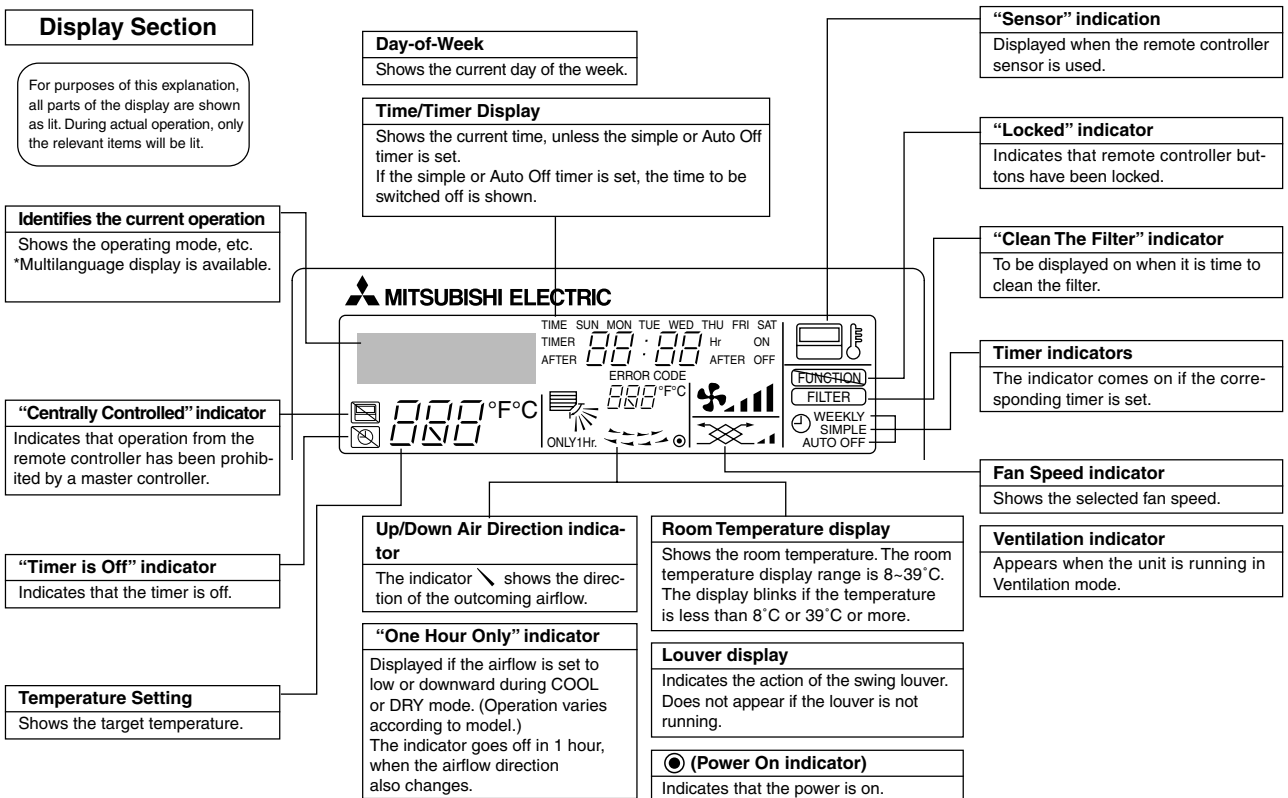

9.3. How to proceed "self-diagnosis"

9.3.1. When a Problem Occurs During Operation

If a problem occurs in the air conditioner, the indoor and outdoor units will stop, and the problem is shown in the remote controller display.

- ① [CHECK] and the refrigerant address are displayed on the temperature display, and the error code and unit number are displayed alternately as shown below. (If the outdoor unit is malfunctioning, the unit number will be "00".)
- ② In the case of group control, for which one remote controller controls multiple refrigerant systems, the refrigerant address and error code of the unit that first experienced trouble (i.e., the unit that transmitted the error code) will be displayed.
- ③ To clear the error code, press the **ON/OFF** button.

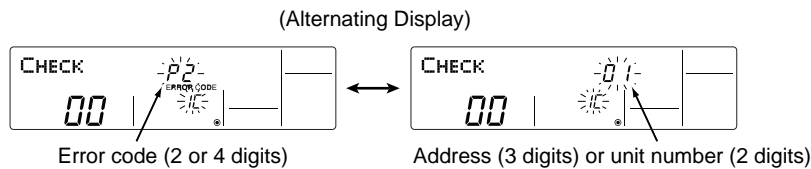
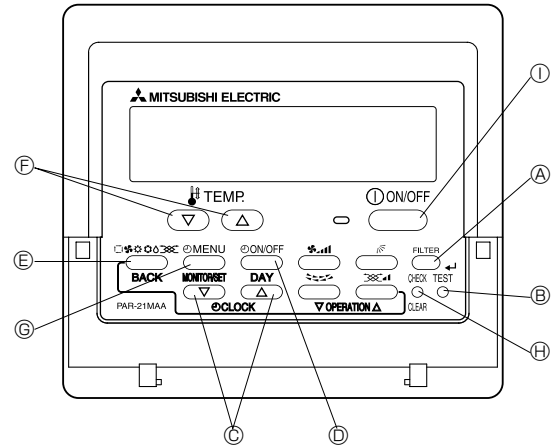

When using remote-/local-controller combined operation, cancel the error code after turning off remote operation. During central control by a MELANS controller, cancel the error code by pressing the **ON/OFF** button.

Self-Diagnosis During Maintenance or Service

Since each unit has a function that stores error codes, the latest check code can be recalled even if it is cancelled by the remote controller or power is turned off.

Check the error code history for each unit using the remote controller.

- ① Switch to self-diagnosis mode.

- ② Press the **CHECK** button twice within 3 seconds. The display content will change as shown below.

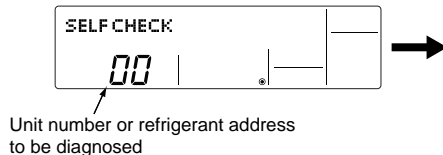

- ③ Set the unit number or refrigerant address you want to diagnose.

- ④ Press the [TEMP] buttons (**TEMP** and **TEMP**) to select the desired number or address. The number (address) changes between [01] and [50] or [00] and [15].

The refrigerant address will begin to blink approximately 3 seconds after being selected and the self-diagnosis process will begin.

- ⑤ Display self-diagnosis results.

<When there is error code history>

(For the definition of each error code, refer to the indoor unit's installation manual or service handbook.)

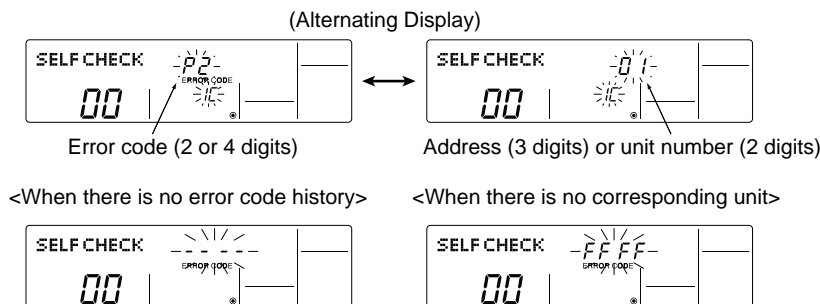

- ⑥ Reset the error history.

Display the error history in the diagnosis result display screen (see step ⑤).

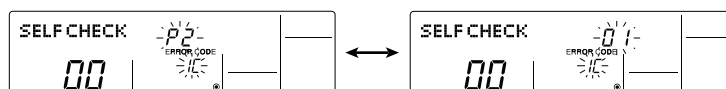

- ④ Press the **ON/OFF** button twice within 3 seconds. The self-diagnosis address or refrigerant address will blink.

When the error history is reset, the display will look like the one shown below. However, if you fail to reset the error history, the error content will be displayed again.

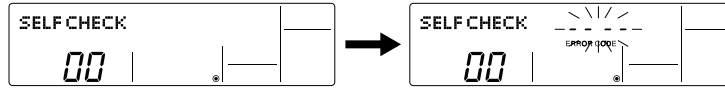

- ⑤ Cancel self-diagnosis.
Self-diagnosis can be cancelled by the following 2 methods.
- ④ Press the **CHECK** button twice within 3 seconds. → Self-diagnosis will be cancelled and the screen will return to the previous state in effect before the start of self-diagnosis.
- ⑤ Press the **ON/OFF** button. → Self-diagnosis will be cancelled and the indoor unit will stop.

9.3.2. Remote Controller Diagnosis

If the air conditioner cannot be operated from the remote controller, diagnose the remote controller as explained below.

- ① First, check that the power-on indicator is lit.
If the correct voltage (DC12 V) is not supplied to the remote controller, the indicator will not light.
If this occurs, check the remote controller's wiring and the indoor unit.

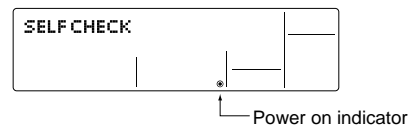

- ② Switch to the remote controller self-diagnosis mode.
- ④ Press the **CHECK** button for 5 seconds or more. The display content will change as shown below.
- ⑤ Press the **FILTER** button to start self-diagnosis.

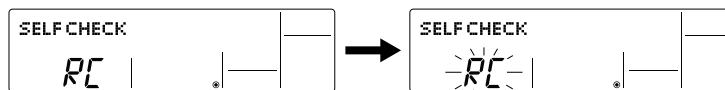

③ Remote controller self-diagnosis result

[When the remote controller is functioning correctly]

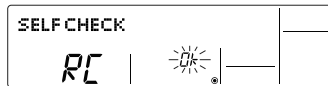

Check for other possible causes, as there is no problem with the remote controller.

[When the remote controller malfunctions]
(Error display 1) "NG" blinks. → The remote controller's transmitting-receiving circuit is defective.

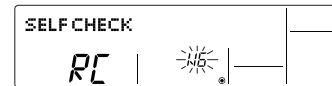

The remote controller must be replaced with a new one.

[Where the remote controller is not defective, but cannot be operated.]
(Error display 2) [E3], [6833] or [6832] blinks. → Transmission is not possible.

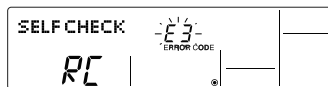

There might be noise or interference on the transmission path, or the indoor unit or other remote controllers are defective. Check the transmission path and other controllers.

(Error display 3) "ERC" and the number of data errors are displayed.
→ Data error has occurred.

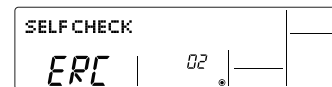

The number of data errors is the difference between the number of bits sent from the remote controller and the number actually transmitted through the transmission path. If such a problem is occurring, the transmitted data is affected by noise, etc. Check the transmission path.

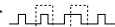
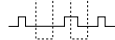
When the number of data errors is "02":
Transmission data from remote controller 
Transmission data on transmission path 

- ④ To cancel remote controller diagnosis
- ④ Press the **CHECK** button for 5 seconds or more. Remote controller diagnosis will be cancelled, "PLEASE WAIT" and operation lamp will blink. After approximately 30 seconds, the state in effect before the diagnosis will be restored.

9.3.3. Malfunction-diagnosis method by remote controller

Refer to the following tables for details on the check codes.

Errors detected by indoor unit

Check code	Symptom	Remark
P1	Intake sensor error	—
P9	Pipe (TH5) sensor error	
P2	Pipe (TH2) sensor error	
E6,E7	Interface controller/outdoor unit communication error	
P6	Freezing/Overheating protection operation	
EE	Communication error between indoor and outdoor units	
P8	Pipe temperature error	
E4, E5	Remote controller signal receiving error	
—	—	
—	—	
Fb	Interface controller system error (memory error, etc.)	
E0, E3	Remote controller transmission error	
E1, E2	Remote controller control board error	

Errors detected by unit other than indoor unit (outdoor unit, etc.)

Check code	Symptom	Remark
E8	Interface controller/outdoor unit communication error (Signal receiving error)	For details, check the LED display of the outdoor controller board.
E9	Interface controller/outdoor unit communication error (Transmitting error) (Outdoor unit)	
UP	Compressor overcurrent interruption	
U3,U4	Open/short of outdoor unit thermistors	
UF	Compressor overcurrent interruption (When compressor locked)	
U2	Abnormal high discharging temperature/insufficient refrigerant	
U1,Ud	Abnormal high pressure (63H worked)/Overheating protection operation	
U5	Abnormal temperature of heatsink	
U8	Outdoor unit fan protection stop	
U6	Compressor overcurrent interruption/Abnormal of power module	
U7	Abnormality of superheat due to low discharge temperature	
U9,UH	Abnormality such as overvoltage or voltage shortage and abnormal synchronous signal to main circuit/Current sensor error	
—	—	
—	—	
Others	Other errors (Refer to the technical manual for the outdoor unit.)	

- If the unit cannot be operated properly after test run, refer to the following table to find the cause.

Symptom		Cause
Wired remote controller	LED 1, 2 (PCB in outdoor unit)	
PLEASE WAIT	For about 2 minutes after power-on	After LED 1, 2 are lighted, LED 2 is turned off, then only LED 1 is lighted. (Correct operation)
PLEASE WAIT → Error code	Subsequent to about 2 minutes after power-on	• For about 2 minutes following power-on, operation of the remote controller is not possible due to system start-up. (Correct operation)
Display messages do not appear even when operation switch is turned ON (operation lamp does not light up).		Only LED 1 is lighted. → LED 1, 2 blink.
		Only LED 1 is lighted. → LED 1 blinks twice, LED 2 blinks once.
		• Incorrect wiring between interface controller and outdoor (incorrect polarity of S1, S2, S3) • Remote controller wire short

Note: Operation is not possible for about 30 seconds after cancellation of function selection. (Correct operation)

For description of each LED (LED1, 2, 3) provided on the interface controller, refer to the following table.
Display detail A (SW 3-1 = OFF, SW 3-2 = OFF, SW 3-3 = OFF)

LED1 (power for microcomputer)	Indicates whether control power is supplied. Make sure that this LED is always lit.
LED2 (power for remote controller)	Indicates whether power is supplied to the remote controller. This LED lights only in the case of the Interface controller which is connected to the outdoor unit refrigerant addresses "0".
LED3 (communication between Interface controller and outdoor units)	Indicates state of communication between the Interface controller and outdoor units. Make sure that this LED is always blinking.

Error code indication

You can check an error code on both ① and ②.

① LCD display on remote controller

② 2-digit LED indicator on outdoor unit PCB

(For SPLIT type outdoor unit, this LED indicator is optional parts.PAC-SK52ST)

* The 2-digit LED indicator on outdoor unit PCB can display indoor side error as well.

SELF-DIAGNOSIS ACTION TABLE

Error Code	Abnormal point and detection method	Cause	Countermeasure										
P1	<p>Target Temperature thermistor (TH1)</p> <p>① The unit is in 3-minute resume prevention mode if short/open of thermistor is detected. Abnormal if the unit does not reset normally after 3 minutes. (The unit returns to normal operation, if it has been reset normally.)</p> <p>② Constantly detected during cooling, drying, and heating operation. Short: -90°C or more Open: -40°C or less</p>	<p>① Defective thermistor characteristics</p> <p>② Contact failure of connector on the interface controller board (Insert failure)</p> <p>③ Breaking of wire or contact failure of thermistor wiring</p> <p>④ Defective interface controller board</p>	<p>①—③ Check resistance value of thermistor.</p> <table border="1"> <tr> <td>0°C</td> <td>15.0kΩ</td> </tr> <tr> <td>10°C</td> <td>9.6kΩ</td> </tr> <tr> <td>20°C</td> <td>6.3kΩ</td> </tr> <tr> <td>30°C</td> <td>4.3kΩ</td> </tr> <tr> <td>40°C</td> <td>3.0kΩ</td> </tr> </table> <p>If you put force on (draw or bend) the lead wire with measuring resistance value of thermistor, breaking of wire or contact failure can be detected.</p> <p>② Check contact failure of connector on the interface controller board. Turn the power on again and check restart after inserting connector again.</p> <p>④ Check <target> temperature display on remote controller. Replace interface controller board if there is abnormal difference with actual <target> temperature.</p> <p>Turn the power off, and on again to operate after check.</p>	0°C	15.0kΩ	10°C	9.6kΩ	20°C	6.3kΩ	30°C	4.3kΩ	40°C	3.0kΩ
0°C	15.0kΩ												
10°C	9.6kΩ												
20°C	6.3kΩ												
30°C	4.3kΩ												
40°C	3.0kΩ												
P2	<p>Pipe temperature thermistor/Liquid (TH2)</p> <p>① The unit is in 3-minute resume prevention mode if short/open of thermistor is detected. Abnormal if the unit does not reset normally after 3 minutes. (The unit returns to normal operation, if it has been reset normally.)</p> <p>② Constantly detected during cooling, drying, and heating (except defrosting) operation Short: 90°C or more Open: -40°C or less</p>	<p>① Defective thermistor characteristics</p> <p>② Contact failure of connector on the interface controller board (Insert failure)</p> <p>③ Breaking of wire or contact failure of thermistor wiring</p> <p>④ Defective refrigerant circuit is causing thermistor temperature of 90°C or more or -40°C or less.</p> <p>⑤ Defective interface controller board</p>	<p>①—③ Check resistance value of thermistor. For characteristics, refer to (P1) above.</p> <p>② Check contact failure of connector on the interface controller board. Turn the power on and check restart after inserting connector again.</p> <p>④ Check pipe <liquid> temperature with remote controller in test run mode. If pipe <liquid> temperature is extremely low (in cooling mode) or high (in heating mode), refrigerant circuit may have defective.</p> <p>⑤ Check pipe <liquid> temperature with remote controller in test run mode. If there is extremely difference with actual pipe <liquid> temperature, replace interface controller board.</p> <p>Turn the power off, and on again to operate after check.</p>										
P9	<p>Pipe temperature thermistor / 2-phase (TH5)</p> <p>① The unit is in 3-minute resume protection mode if short/open of thermistor is detected. Abnormal if the unit does not get back to normal within 3 minutes. (The unit returns to normal operation, if it has been reset normally.)</p> <p>② Constantly detected during cooling, drying, and heating operation (except defrosting) Short: 90°C or more Open: -40°C or less</p>	<p>① Defective thermistor characteristics</p> <p>② Contact failure of connector on the interface controller board (Insert failure)</p> <p>③ Breaking of wire or contact failure of thermistor wiring</p> <p>④ Temperature of thermistor is 90°C or more or -40°C or less caused by defective refrigerant circuit.</p> <p>⑤ Defective interface controller board</p>	<p>①—③ Check resistance value of thermistor. For characteristics, refer to (P1) above.</p> <p>② Check contact failure of connector on the interface controller board. Turn the power on and check restart after inserting connector again.</p> <p>④ Operate in test run mode and check pipe <2-phase> temperature with outdoor controller circuit board. If pipe <2-phase> temperature is extremely low (in cooling mode) or high (in heating mode), refrigerant circuit may have defect.</p> <p>⑤ Operate in test run mode and check pipe <2-phase> temperature with outdoor control circuit board. If there is extreme difference with actual pipe <2-phase> temperature, replace interface controller board. There is no abnormality if none of above comes within the unit. Turn the power off and on again to operate.</p> <p>(In case of checking pipe temperature with outdoor controller circuit board, be sure to connect A-control service tool (PAC-SK52ST).)</p>										



Error Code	Abnormal point and detection method	Cause	Countermeasure
P6	<p>Freezing/overheating protection is working</p> <p>① Freezing protection (Cooling mode) The unit is in 6-minute resume prevention mode if pipe <liquid or 2-phase> temperature stays under -15°C for 3 minutes, 3 minutes after the compressor started. Abnormal if it stays under -15°C for 3 minutes again within 16 minutes after 6-minute resume prevention mode.</p> <p>② Overheating protection (Heating mode) The units is in 6 minute resume prevention mode if pipe <2-phase> temperature is detected as over 70°C after the compressor started. Abnormal if the temperature of over 70°C is detected again within 30 minutes after 6 minute resume prevention mode.</p>	<p>(Cooling or drying mode)</p> <p>① Clogged filter (reduced airflow) ② Short cycle of air path ③ Low-load (low temperature) operation out of the tolerance range ④ Defective indoor fan motor • Fan motor is defective. • Indoor controller board is defective.</p> <p>⑤ Defective outdoor fan control ⑥ Overcharge of refrigerant ⑦ Defective refrigerant circuit (clogs)</p> <p>(Heating mode)</p> <p>① Clogged filter (reduced airflow) ② Short cycle of air path ③ Over-load (high temperature) operation out of the tolerance range ④ Defective indoor fan motor • Fan motor is defective. • Indoor controller board is defective. ⑤ Defective outdoor fan control ⑥ Overcharge of refrigerant ⑦ Defective refrigerant circuit (clogs) ⑧ Bypass circuit of outdoor unit is defective.</p>	<p>(Cooling or drying mode)</p> <p>① Check clogs of the filter. ② Remove shields.</p> <p>④ Check indoor fan motor.</p> <p>⑤ Check outdoor fan motor. ⑥⑦ Check operating condition of refrigerant circuit.</p> <p>(Heating mode)</p> <p>① Check clogs of the filter. ② Remove shields.</p> <p>④ Check indoor fan motor.</p> <p>⑤ Check outdoor fan motor. ⑥-⑧ Check operating condition of refrigerant circuit.</p>
P8	<p>Pipe temperature <Cooling mode> Detected as abnormal when the pipe temperature is not in the cooling range 3 minutes after compressor start and 6 minutes after the liquid or 2-phase pipe is out of cooling range. Note 1) It takes at least 9 minutes to detect. Note 2) Abnormality P8 is not detected in drying mode. Cooling range : -3 °C ≧ (TH-TH1) TH: Lower temperature between: liquid pipe temperature (TH2) and 2-phase temperature (TH5) TH1: Target temperature</p> <p><Heating mode> When 10 seconds have passed after the compressor starts operation and the hot adjustment mode has finished, the unit is detected as abnormal when 2-phase pipe temperature is not in heating range within 20 minutes.</p> <p>Note 3) It takes at least 27 minutes to detect abnormality. Note 4) It excludes the period of defrosting. (Detection restarts when defrosting mode is over.) Heating range : 3 °C ≦ (TH5-TH1)</p>	<p>① Slight temperature difference between TH1 temperature and pipe <liquid or 2-phase> temperature thermistor • Shortage of refrigerant • Disconnected holder of pipe <liquid or 2-phase> thermistor • Defective refrigerant circuit</p> <p>② Converse connection of extension pipe (on plural units connection)</p> <p>③ Converse wiring of interface/ outdoor unit connecting wire (on plural units connection)</p> <p>④ Defective detection of target temperature and pipe <2-phase> temperature thermistor</p> <p>⑤ Stop valve is not opened completely.</p>	<p>①-④ Check pipe <liquid or 2-phase> temperature with target temperature display on remote controller and outdoor controller circuit board. Pipe <liquid or 2-phase> temperature display is indicated by setting SW2 of outdoor controller circuit board as follows.</p> <p>(Conduct temperature check with outdoor controller circuit board after connecting 'A-Control Service Tool(PAC-SK52ST)')</p> <p>②③ Check converse connection of extension pipe or converse wiring of interface/outdoor unit connecting wire.</p>



Error Code	Abnormal point and detection method	Case	Judgment and action
E0 or E4	<p>Remote controller transmission error (E0)/signal receiving error (E4)</p> <p>① Abnormal if main or sub remote controller cannot receive any transmission normally from Interface unit of refrigerant address "0" for 3 minutes. (Error code: E0)</p> <p>② Abnormal if sub-remote controller could not receive any signal for 2 minutes. (Error code: E0)</p> <p>① Abnormal if Interface controller board can not receive any data normally from remote controller board or from other Interface controller board for 3 minutes. (Error code: E4)</p> <p>② Interface controller board cannot receive any signal from remote controller for 2 minutes. (Error code: E4)</p>	<p>① Contact failure at transmission wire of remote controller</p> <p>② All remote controllers are set as "sub" remote controller. In this case, E0 is displayed on remote controller, and E4 is displayed at LED (LED1, LED2) on the outdoor controller circuit board.</p> <p>③ Miswiring of remote controller</p> <p>④ Defective transmitting receiving circuit of remote controller</p> <p>⑤ Noise has entered into the transmission wire of remote controller.</p>	<p>① Check disconnection or looseness of Interface unit or transmission wire of remote controller.</p> <p>② Set one of the remote controllers "main", If there is no problem with the action above.</p> <p>③ Check wiring of remote controller.</p> <ul style="list-style-type: none"> • Total wiring length: max. 500 m (Do not use cablex 3 or more.) • The number of connecting remote controller: max. 2 units <p>When it is not the above-mentioned problem of ① ~ ③</p> <p>④ Diagnose remote controllers.</p> <p>a) When "RC OK" is displayed, remote controllers have no problem. Turn the power off, and on again to check. If abnormality generates again, replace Interface controller board.</p> <p>b) When "RC NG" is displayed, replace remote controller.</p> <p>c) When "RC E3" or "ERC 00-66" is displayed, noise may be causing abnormality.</p>
E1 or E2	<p>Remote controller control board</p> <p>① Abnormal if data cannot be read normally from the nonvolatile memory of the remote controller control board. (Error code: E1)</p> <p>② Abnormal if the clock function of remote controller cannot be operated normally. (Error code: E2)</p>	<p>① Defective remote controller</p>	<p>① Replace remote controller.</p>
E3 or E5	<p>Remote controller transmission error (E3)/signal receiving error (E5)</p> <p>① Abnormal if remote controller could not find blank of transmission path for 6 seconds and could not transmit. (Error code: E3)</p> <p>② When remote controller receives the transmitted data same time and compares these data. Abnormal if the data is judged to be different for 30 continuous times. (Error code: E3)</p> <p>① Abnormal if Interface controller board could not find blank of transmission path. (Error code: E5)</p> <p>② When Interface controller receives the transmitted data same time and compares these data. Abnormal if the data is judged to be different for 30 continuous times. (Error code: E5)</p>	<p>① 2 remote controllers are set as "main." (In case of 2 remote controllers)</p> <p>② Defective transmitting receiving circuit of remote controller</p> <p>③ Defective transmitting receiving circuit of Interface controller board</p> <p>④ Noise has entered into transmission wire of remote controller.</p>	<p>① Set a remote controller to main, and the other to sub.</p> <p>②~④ Diagnose remote controller.</p> <p>a) When "RC OK" is displayed, remote controllers have no problem. Turn the power off, and on again to check. When becoming abnormal again, replace interface controller board.</p> <p>b) When "RC NG" is displayed, replace remote controller.</p> <p>c) When "RC E3" or "ERC 00-66" is displayed, noise may be causing abnormality.</p>



Error Code	Abnormal point and detection method	Case	Judgment and action
E6	Interface unit/outdoor unit communication error (Signal receiving error) ① Abnormal if Interface controller board cannot receive any signal normally for 6 minutes after turning the power on. ② Abnormal if Interface controller board cannot receive any signal normally for 3 minutes.	① Contact failure, short circuit or, miswiring (converse wiring) of Interface unit/outdoor unit connecting wire ② Defective transmitting receiving circuit of Interface controller board ③ Defective transmitting receiving circuit of Interface controller board ④ Noise has entered into Interface unit/outdoor unit connecting wire.	* Check LED display on the outdoor control circuit board. (Connect A-control service tool, PAC-SK52ST.) ① Check disconnection or looseness of Interface unit/outdoor unit connecting wire of Interface unit or outdoor unit. ②~④ Turn the power off, and on again to check. If abnormality generates again, replace Interface controller board or outdoor controller circuit board.
E8	Interface unit/outdoor unit communication error (Signal receiving error) (Outdoor unit) Abnormal if outdoor controller circuit board could not receive anything normally for 3 minutes.	① Contact failure of Interface unit/outdoor unit connecting wire ② Defective communication circuit of outdoor controller circuit board ③ Defective communication circuit of Interface controller board ④ Noise has entered into Interface unit/outdoor unit connecting wire.	① Check disconnection or looseness of Interface unit/outdoor unit connecting wire of Interface unit or outdoor unit. ②~④ Turn the power off, and on again to check. Replace Interface controller board or outdoor controller circuit board if abnormality is displayed again.
E9	Interface unit/outdoor unit communication error (Transmitting error) (Outdoor unit) (1) Abnormal if "0" receiving is detected 30 times continuously though outdoor controller circuit board has transmitted "1". (2) Abnormal if outdoor controller circuit board could not find blank of transmission path for 3 minutes.	① Interface unit/outdoor unit connecting wire has contact failure. ② Defective communication circuit of outdoor controller circuit board ③ Noise has entered power supply. ④ Noise has entered Interface unit/outdoor unit connecting wire.	① Check disconnection or looseness of Interface unit/outdoor unit connecting wire. ②~④ Turn the power off, and on again to check. Replace outdoor controller circuit board if abnormality is displayed again.
EF	Non defined error code This code is displayed when non defined error code is received.	① Noise has entered transmission wire of remote controller. ② Noise has entered Interface unit/outdoor unit connecting wire.	①② Turn the power off, and on again to check. Replace Interface controller board or outdoor controller circuit board if abnormality is displayed again.
Ed	Serial communication error Abnormal if serial communication between outdoor controller circuit board and outdoor power circuit board is defective.	① Wire disconnection or contact failure of connector CN2 between the outdoor controller circuit board and the outdoor power circuit board ② Wire disconnection or contact failure of connector CN4 between the outdoor controller circuit board and the outdoor power circuit board ③ Defective communication circuit of outdoor power circuit board ④ Defective communication circuit of outdoor controller circuit board for outdoor power circuit board	①② Check connection of each connector CN2 and CN4 between the outdoor controller circuit board and the outdoor power circuit board. ③ Replace outdoor power circuit board. ④ Replace outdoor controller circuit board.

9.3.4. HOW TO "MONITOR THE OPERATION DATA"

- Turn on the [Monitoring the operation data]

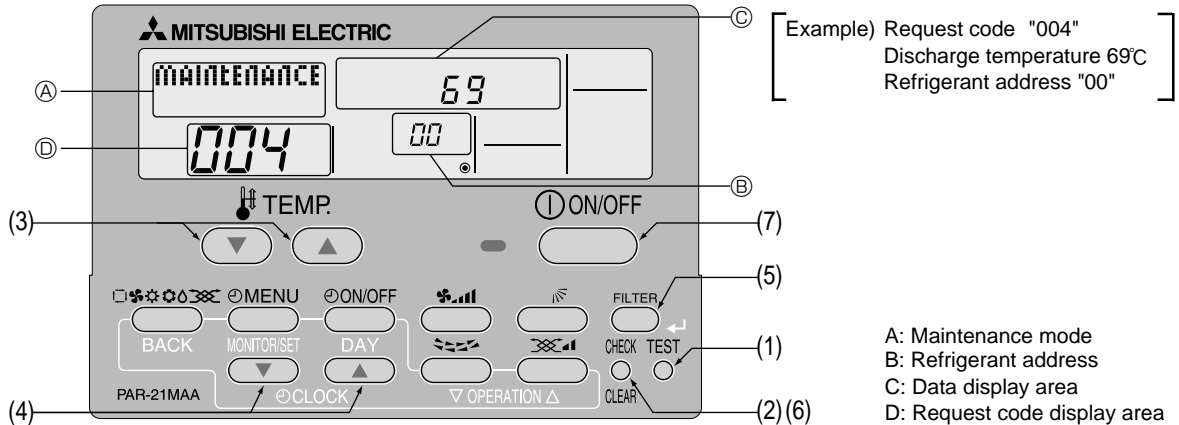

(1) Press the **TEST** button for 3 seconds so that [Maintenance mode] appears on the screen (at A).

(2) Press the **CHECK** button for 3 seconds to switch to [Maintenance monitor].

Note) It is not possible to switch to [Maintenance monitor] during data request in maintenance mode (i.e., while " - - - " is blinking) since no buttons are operative.

- Operating the service inspection monitor

[- - -] appears on the screen (at B) when [Maintenance monitor] is activated.

(The display (at B) now allows you to set a request code No.)

(3) Press the [TEMP] buttons (**▽** and **△**) to select the desired refrigerant address.



(4) Press the [CLOCK] buttons (**▽** and **△**) to set the desired request code No.

(5) Press the **FILTER** button to perform data request.

(The requested data will be displayed at C in the same way as in maintenance mode.)

Data collected during operation of the remote controller will be displayed.

The collected data such as temperature data will not be updated automatically even if the data changes.

To display the updated data, carry out step (4) again.

- Canceling the Monitoring the operation data

(6) While [Maintenance monitor] is displayed, press the **CHECK** button for 3 seconds to return to maintenance mode.

(7) To return to normal mode, press the **ON/OFF** button.

9.4. Request code list

* Certain interface/outdoor combinations do not have the request code function; therefore, no request codes are displayed.

Request code	Request content	Description (Display range)	Unit	Remarks
0	Operation state	Refer to 9.4.1. Detail Contents in Request Code.	–	
1	Compressor-Operating current (rms)	0 – 50	A	
2	Compressor-Accumulated operating time	0 – 9999	10 hours	
3	Compressor-Number of operation times	0 – 9999	100 times	
4	Discharge temperature (TH4)	3 – 217	°C	
5	Outdoor unit - Liquid pipe 1 temperature (TH3)	-40 – 90	°C	
6	Outdoor unit - Liquid pipe 2 temperature	-40 – 90	°C	
7	Outdoor unit-2-phase pipe temperature (TH6)	-39 – 88	°C	
8	Outdoor unit-Suction pipe temperature (TH32)	-39 – 88	°C	
9	Outdoor unit-Outside air temperature (TH7)	-39 – 88	°C	
10	Outdoor unit-Heatsink temperature (TH8)	-40 – 200	°C	
11				
12	Discharge superheat (SHd)	0 – 255	°C	
13	Sub-cool (SC)	0 – 130	°C	
14				
15				
16	Compressor-Operating frequency	0 – 255	Hz	
17	Compressor-Target operating frequency	0 – 255	Hz	
18	Outdoor unit-Fan output step	0 – 10	Step	
19	Outdoor unit-Fan 1 speed (Only for air conditioners with DC fan motor)	0 – 9999	rpm	
20	Outdoor unit-Fan 2 speed (Only for air conditioners with DC fan motor)	0 – 9999	rpm	"0" is displayed if the air conditioner is a single-fan type.
21				
22	LEV (A) opening	0 – 500	Pulses	
23	LEV (B) opening	0 – 500	Pulses	
24	LEV (C) opening	0 – 500	Pulses	
25	Primary current	0 – 50	A	
26	DC bus voltage	180 – 370	V	
27				
28				
29	Number of connected indoor units	0 – 4	Units	
30	Interface unit-Setting temperature	17 – 30	°C	
31	Interface unit-Target temperature <Measured by thermostat>	8 – 39	°C	
32	Interface unit-Target temperature (Unit No. 1) <Heat mode-4-deg correction>	8 – 39	°C	"0" is displayed if the target unit is not present.
33	Interface unit-Target temperature (Unit No. 2) <Heat mode-4-deg correction>	8 – 39	°C	↑
34	Interface unit-Target temperature (Unit No. 3) <Heat mode-4-deg correction>	8 – 39	°C	↑
35	Interface unit-Target temperature (Unit No. 4) <Heat mode-4-deg correction>	8 – 39	°C	↑
36				
37	Interface unit - Liquid pipe temperature (Unit No. 1)	-39 – 88	°C	"0" is displayed if the target unit is not present.
38	Interface unit - Liquid pipe temperature (Unit No. 2)	-39 – 88	°C	↑
39	Interface unit - Liquid pipe temperature (Unit No. 3)	-39 – 88	°C	↑
40	Interface unit - Liquid pipe temperature (Unit No. 4)	-39 – 88	°C	↑
41				
42	Interface unit-2-phase. pipe temperature (Unit No. 1)	-39 – 88	°C	"0" is displayed if the target unit is not present.
43	Interface unit-2-phase. pipe temperature (Unit No. 2)	-39 – 88	°C	↑
44	Interface unit-2-phase. pipe temperature (Unit No. 3)	-39 – 88	°C	↑
45	Interface unit-2-phase. pipe temperature (Unit No. 4)	-39 – 88	°C	↑
46				
47				
48	Thermostat ON operating time	0 – 999	Minutes	
49	Test run elapsed time	0 – 120	Minutes	← Not possible to activate maintenance mode during the test run.



Request code	Request content	Description (Display range)	Unit	Remarks
50	Interface unit-Control state	Refer to 9.4.1.Detail Contents in Request Code.	—	
51	Outdoor unit-Control state	Refer to 9.4.1.Detail Contents in Request Code.	—	
52	Compressor-Frequency control state	Refer to 9.4.1.Detail Contents in Request Code.	—	
53	Outdoor unit-Fan control state	Refer to 9.4.1.Detail Contents in Request Code.	—	
54	Actuator output state	Refer to 9.4.1.Detail Contents in Request Code.	—	
55	Error content (U9)	Refer to 9.4.1.Detail Contents in Request Code.	—	
56				
57				
58				
59				
60	Signal transmission demand capacity	0 – 255	%	
61	Contact demand capacity	Refer to 9.4.1.Detail Contents in Request Code.	—	
62	External input state (silent mode, etc.)	Refer to 9.4.1.Detail Contents in Request Code.	—	
63				
64				
65				
66				
67				
68				
69				
70	Outdoor unit-Capacity setting display	Refer to 9.4.1.Detail Contents in Request Code.	—	
71	Outdoor unit-Setting information	Refer to 9.4.1.Detail Contents in Request Code.	—	
72				
73	Outdoor unit-SW1 setting information	Refer to 9.4.1.Detail Contents in Request Code.	—	
74	Outdoor unit-SW2 setting information	Refer to 9.4.1.Detail Contents in Request Code.	—	
75				
76	Outdoor unit-SW4 setting information	Refer to 9.4.1.Detail Contents in Request Code.	—	
77	Outdoor unit-SW5 setting information	Refer to 9.4.1.Detail Contents in Request Code.	—	
78	Outdoor unit-SW6 setting information	Refer to 9.4.1.Detail Contents in Request Code.	—	
79	Outdoor unit-SW7 setting information	Refer to 9.4.1.Detail Contents in Request Code.	—	
80	Outdoor unit-SW8 setting information	Refer to 9.4.1.Detail Contents in Request Code.	—	
81	Outdoor unit-SW9 setting information	Refer to 9.4.1.Detail Contents in Request Code.	—	
82	Outdoor unit-SW10 setting information	Refer to 9.4.1.Detail Contents in Request Code.	—	
83				
84	M-NET adapter connection (presence/absence)	"0000": Not connected "0001": Connected	—	
85				
86				
87				
88				
89	Display of execution of replace/wash operation	"0000": Not washed "0001": Washed	—	
90	Outdoor unit-Microcomputer version information	Examples) Ver 5.01 → "0501"	Ver	
91	Outdoor unit-Microcomputer version information (sub No.)	Auxiliary information (displayed after version information) Examples) Ver 5.01 A000 → "A000"	—	
92				
93				
94				
95				
96				
97				
98				
99				
100	Outdoor unit - Error postponement history 1 (latest)	Displays postponement code. (" - - " is displayed if no postponement code is present)	Code	
101	Outdoor unit - Error postponement history 2 (previous)	Displays postponement code. (" - - " is displayed if no postponement code is present)	Code	
102	Outdoor unit - Error postponement history 3 (last but one)	Displays postponement code. (" - - " is displayed if no postponement code is present)	Code	



Request code	Request content	Description (Display range)	Unit	Remarks
103	Error history 1 (latest)	Displays error history. ("-" is displayed if no history is present.)	Code	
104	Error history 2 (second to last)	Displays error history. ("-" is displayed if no history is present.)	Code	
105	Error history 3 (third to last)	Displays error history. ("-" is displayed if no history is present.)	Code	
106	Abnormal thermistor display (TH3/TH6/TH7/TH8)	3 : TH3 6 : TH6 7 : TH7 8 : TH8 0 : No thermistor error	Sensor number	
107	Operation mode at time of error	Displayed in the same way as request code "0".	-	
108	Compressor-Operating current at time of error	0 - 50	A	
109	Compressor-Accumulated operating time at time of error	0 - 9999	10 hours	
110	Compressor-Number of operation times at time of error	0 - 9999	100 times	
111	Discharge temperature at time of error	3 - 217	°C	
112	Outdoor unit - Liquid pipe 1 temperature (TH3) at time of error	-40 - 90	°C	
113	Outdoor unit - Liquid pipe 2 temperature at time of error	-40 - 90	°C	
114	Outdoor unit-2-phase pipe temperature (TH6) at time of error	-39 - 88	°C	
115				
116	Outdoor unit-Outside air temperature (TH7) at time of error	-39 - 88	°C	
117	Outdoor unit-Heatsink temperature (TH8) at time of error	-40 - 200	°C	
118	Discharge superheat (SHd) at time of error	0 - 255	°C	
119	Sub-cool (SC) at time of error	0 - 130	°C	
120	Compressor-Operating frequency at time of error	0 - 255	Hz	
121	Outdoor unit at time of error • Fan output step	0 - 10	Step	
122	Outdoor unit at time of error • Fan 1 speed (Only for air conditioners with DC fan)	0 - 9999	rpm	
123	Outdoor unit at time of error • Fan 2 speed (Only for air conditioners with DC fan)	0 - 9999	rpm	"0" is displayed if the air conditioner is a single-fan type.
124				
125	LEV (A) opening at time of error	0 - 500	Pulses	
126	LEV (B) opening at time of error	0 - 500	Pulses	
127				
128				
129				
130	Thermostat ON time until operation stops due to error	0 - 999	Minutes	
131				
132	Interface - Liquid pipe temperature at time of error	-39 - 88	°C	Average value of all indoor units is displayed if the air conditioner consists of two or more indoor units (twin, triple, quad).
133	Interface-2-phase pipe temperature at time of error	-39 - 88	°C	Average value of all indoor units is displayed if the air conditioner consists of two or more indoor units (twin, triple, quad).
134	Interface at time of error • Target temperature <Thermostat judge temperature>	-39 - 88	°C	
135				
136				
137				
138				
139				
140				
~				
146				
147				
148				
149				
150	Interface-Actual intake air temperature	-39 - 88	°C	
151	Interface-Liquid pipe temperature	-39 - 88	°C	
152	Interface-2-phase pipe temperature	-39 - 88	°C	
153				
~				
767				

9.4.1 Detail Contents in Request Code

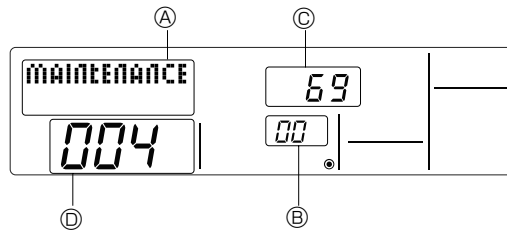

[Example) Request code "004"
Discharge temperature 69°C
Refrigerant address "00"]

- A: Maintenance mode display
- B: Refrigerant address
- C: Data display area
- D: Request code display area

[Operation state] (Request code "0")

Data display

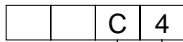

Relay output state
Operation mode

Operation mode

Display	Operation mode
0	STOP • FAN
C	COOL • DRY
H	HEAT
d	DEFROST

Relay output state

Display	Power currently supplied to compressor	Compressor	4-way valve	Solenoid valve
0	—	—	—	—
1				ON
2			ON	
3			ON	ON
4		ON		
5		ON		ON
6		ON	ON	
7		ON	ON	ON
8	ON			
A	ON		ON	

[Interface unit – Control state] (Request code : "50 ")

Data display

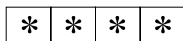

Unit No. 4 state
Unit No. 3 state
Unit No. 2 state
Unit No. 1 state

Display	State
0	Normal
1	Preparing for heat operation
2	—
3	—
4	Heater is ON.
5	Anti-freeze protection is ON.
6	Overheat protection is ON.
7	Requesting compressor to turn OFF
F	There are no corresponding units.

[Outdoor unit – Control state] (Request code "51")

Data display	State
0 0 0 0	Normal
0 0 0 1	Preparing for heat operation
0 0 0 2	Defrost

[Compressor – Frequency control state] (Request code "52")

Data display

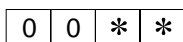

Frequency control state ②
Frequency control state ①

Frequency control state ①

Display	Current limit control
0	No current limit
1	Primary current limit control is ON.
2	Secondary current limit control is ON.

Frequency control state ②

Display	Discharge temperature overheat prevention	Condensation temperature overheat prevention	Anti-freeze protection control	Heatsink temperature overheat prevention
0				
1	Controlled			
2		Controlled		
3	Controlled	Controlled		
4			Controlled	
5	Controlled		Controlled	
6		Controlled	Controlled	
7	Controlled	Controlled	Controlled	
8				Controlled
9	Controlled			Controlled
A		Controlled		Controlled
b	Controlled	Controlled		Controlled
C			Controlled	Controlled
d	Controlled		Controlled	Controlled
E		Controlled	Controlled	Controlled
F	Controlled	Controlled	Controlled	Controlled

[Fan control state] (Request code : "53")

Data display

0	0	*	*
---	---	---	---

— Fan step correction value by heatsink temperature overheat prevention control
 — Fan step correction value by cool condensation temperature overheat prevention control

Display	Correction value
- (minus)	- 1
0	0
1	+1
2	+2

[Actuator output state] (Request code : "54")

Data display

0	0	*	*
---	---	---	---

— Actuator output state ①
 — Actuator output state ②

Actuator output state ①

Display	SV1	4-way valve	Compressor	Compressor is warming up
0				
1	ON			
2		ON		
3	ON	ON		
4			ON	
5	ON		ON	
6		ON	ON	
7	ON	ON	ON	
8				ON
9	ON			ON
A		ON		ON
b	ON	ON		ON
C			ON	ON
d	ON		ON	ON
E		ON	ON	ON
F	ON	ON	ON	ON

Actuator output state ②

Display	52C	SV2	SS
0			
1	ON		
2		ON	
3	ON	ON	
4			ON
5	ON		ON
6		ON	ON
7	ON	ON	ON

[Error content (U9)] (Request code : "55")

Data display

0	0	*	*
---	---	---	---

— Error content ①
 — Error content ②

Error content ①

● : Detected

Display	Overtoltage error	Undervoltage error	L1-phase open error	Power synchronizing signal error
0				
1	●			
2		●		
3	●	●		
4			●	
5	●		●	
6		●	●	
7	●	●	●	
8				●
9	●			●
A		●		●
b	●	●		●
C			●	●
d	●		●	●
E		●	●	●
F	●	●	●	●

Error content ②

● : Detected

Display	Converter Fo error	PAM error
0		
1	●	
2		●
3	●	●

[Contact demand capacity] (Request code "61")

Data display

0	0	0	*
---	---	---	---

 Setting content

Setting content

Display	Setting value	Setting	
		SW7-1	SW7-2
0	0%		
1	50%	ON	
2	75%		ON
3	100%	ON	ON

[External input state] (Request code "62")

Data display

0	0	0	*
---	---	---	---

 Input state

Input state

● : Input present

Display	Contact demand input	Silent mode input	Spare 1 input	Spare 2 input
0				
1	●			
2		●		
3	●	●		
4			●	
5	●		●	
6		●	●	
7	●	●	●	
8				●
9	●			●
A		●		●
b	●	●		●
C			●	●
d	●		●	●
E		●	●	●
F	●	●	●	●

[Outdoor unit - Capacity setting display] (Request code : "70")

Data display	Capacity
9	35
10	50
11	60
14	71
20	100
25	125
28	140
40	200
50	250

[Outdoor unit - Setting information] (Request code "71")

Data display

0	0	*	*
---	---	---	---

 Setting information ①
Setting information ②

Setting information ①

Display	Defrost mode
0	Standard
1	For high humidity

Setting information ②

Display	Single-/3-phase	Heat pump/cooling only
0	Single-phase	Heat pump
1		Cooling only
2	3-phase	Heat pump
3		Cooling only

[Outdoor unit switch setting display (SW1 to SW10, except SW3)] Request codes: 73 to 82

0: Swich OFF 1: Swich ON

SW1, SW2, SW6, SW7						Data display
1	2	3	4	5	6	
0	0	0	0	0	0	00 00
1	0	0	0	0	0	00 01
0	1	0	0	0	0	00 02
1	1	0	0	0	0	00 03
0	0	1	0	0	0	00 04
1	0	1	0	0	0	00 05
0	1	1	0	0	0	00 06
1	1	1	0	0	0	00 07
0	0	0	1	0	0	00 08
1	0	0	1	0	0	00 09
0	1	0	1	0	0	00 0A
1	1	0	1	0	0	00 0b
0	0	1	1	0	0	00 0C
1	0	1	1	0	0	00 0d
0	1	1	1	0	0	00 0E
1	1	1	1	0	0	00 0F
0	0	0	0	1	0	00 10
1	0	0	0	1	0	00 11
0	1	0	0	1	0	00 12
1	1	0	0	1	0	00 13
0	0	1	0	1	0	00 14
1	0	1	0	1	0	00 15
0	1	1	0	1	0	00 16
1	1	1	0	1	0	00 17
0	0	0	1	1	0	00 18
1	0	0	1	1	0	00 19
0	1	0	1	1	0	00 1A
1	1	0	1	1	0	00 1B
0	0	1	1	1	0	00 1C
1	0	1	1	1	0	00 1D
0	1	1	1	1	0	00 1E
1	1	1	1	1	0	00 1F
0	0	0	0	0	1	00 20
1	0	0	0	0	1	00 21
0	1	0	0	0	1	00 22
1	1	0	0	0	1	00 23
0	0	1	0	0	1	00 24
1	0	1	0	0	1	00 25
0	1	1	0	0	1	00 26
1	1	1	0	0	1	00 27
0	0	0	1	0	1	00 28
1	0	0	1	0	1	00 29
0	1	0	1	0	1	00 2A
1	1	0	1	0	1	00 2B
0	0	1	1	0	1	00 2C
1	0	1	1	0	1	00 2D
0	1	1	1	0	1	00 2E
1	1	1	1	0	1	00 2F
0	0	0	0	1	1	00 30
1	0	0	0	1	1	00 31
0	1	0	0	1	1	00 32
1	1	0	0	1	1	00 33
0	0	1	0	1	1	00 34
1	0	1	0	1	1	00 35
0	1	1	0	1	1	00 36
1	1	1	0	1	1	00 37
0	0	0	1	1	1	00 38
1	0	0	1	1	1	00 39
0	1	0	1	1	1	00 3A
1	1	0	1	1	1	00 3B
0	0	1	1	1	1	00 3C
1	0	1	1	1	1	00 3D
0	1	1	1	1	1	00 3E
1	1	1	1	1	1	00 3F

0: Swich OFF 1: Swich ON

SW5				Data display
1	2	3	4	
0	0	0	0	00 00
1	0	0	0	00 01
0	1	0	0	00 02
1	1	0	0	00 03
0	0	1	0	00 04
1	0	1	0	00 05
0	1	1	0	00 06
1	1	1	0	00 07
0	0	0	1	00 08
1	0	0	1	00 09
0	1	0	1	00 0A
1	1	0	1	00 0b
0	0	1	1	00 0C
1	0	1	1	00 0d
0	1	1	1	00 0E
1	1	1	1	00 0F

0: Swich OFF 1: Swich ON

SW8			Data display
1	2	3	
0	0	0	00 00
1	0	0	00 01
0	1	0	00 02
1	1	0	00 03
0	0	1	00 04
1	0	1	00 05
0	1	1	00 06
1	1	1	00 07

0: Swich OFF 1: Swich ON

SW4, SW9, SW10		Data display
1	2	
0	0	00 00
1	0	00 01
0	1	00 02
1	1	00 03

10. Central control

When connected with the outdoor unit, M-NET converter and A-control sub Interface can be connected to MELANS and BMS, which enables the central control available.

As for the demand control setting, the central control is not available in the fixed capacity mode. However, with the wired remote controller method(Auto step mode), the central control is available.

Operation with MELANS / BMS

Set the switch from the following setting according to the specifications of the local unit.

Ex. Local unit with only heating : select the ② or ③ below.

- ① Operation function : ON/OFF, operation mode change, the set temperature change

Switch setting

SW1-1=OFF SW1-2=ON SW1-3=ON SW1-4~8=OFF
SW2-1~5=OFF SW 2-6=ON SW2-7,8=OFF

- ② Operation function : ON/OFF, the set temperature change

Switch setting

SW1-1=OFF SW1-2=ON SW1-3=ON SW1-4~8=OFF
SW2-3~5=OFF SW 2-6=ON SW2-7,8=OFF

(Operation mode is determined by the setting of SW2-1, 2. MELANS and BMS cannot operate this setting.)

- ③ Operation function : ON/OFF, operation mode change

Switch setting

SW1-1=OFF SW1-2=ON SW1-3=ON SW1-4~8=OFF
SW1,2=OFF SW 2-6=ON SW2-7,8=OFF

(Set temperature is determined by the setting of SW2-3~5. MELANS and BMS cannot operate this setting.)

- ④ Operation function : ON/OFF

Switch setting

SW1-1=OFF SW1-2=ON SW1-3=ON SW1-4~8=OFF
SW 2-6=ON SW2-7,8=OFF

(Operation mode and set temperature are determined by the setting of SW2-1~5. MELANS and BMS cannot operate this setting.)

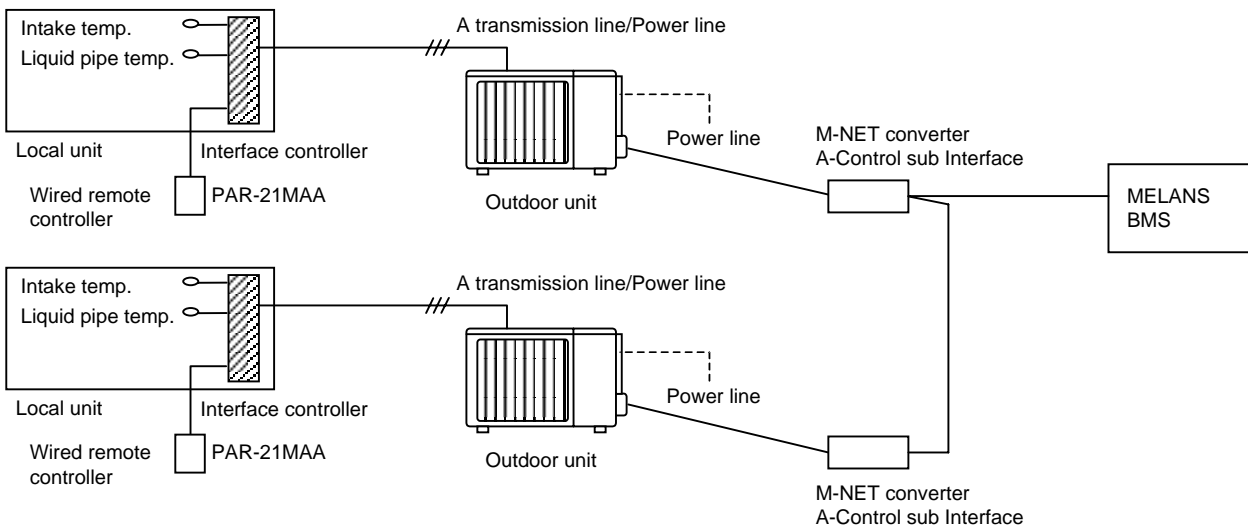



11. Outlines and dimensions

Unit : mm

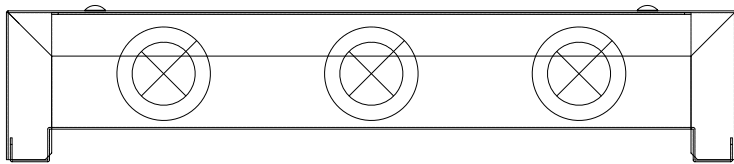
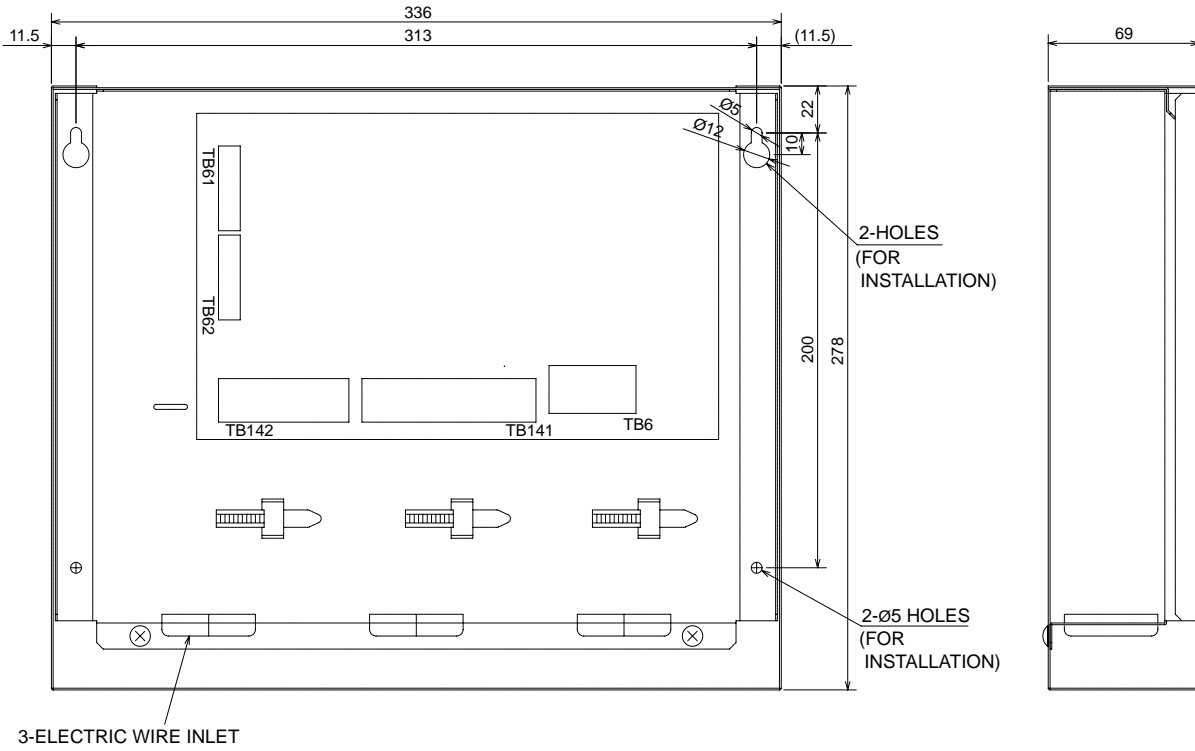
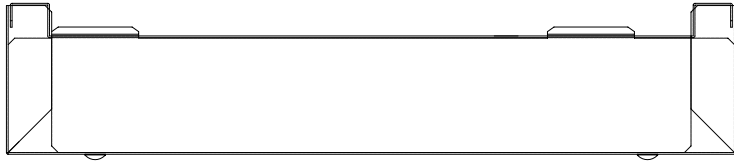



12. Troubleshooting

A flowing water sound or occasional hissing sound is heard.	<ul style="list-style-type: none">■ These sounds can be heard when refrigerant is flowing in the indoor unit, refrigerant pipe or when the refrigerant is changing.
Water does not heat or cool well.	<ul style="list-style-type: none">■ Clean the filter of water piping. (Flow is reduced when the filter is dirty or clogged.)■ Check the temperature adjustment and adjust the set temperature.■ Make sure that there is plenty of space around the outdoor unit.
Water or vapor is emitted from the outdoor unit.	<ul style="list-style-type: none">■ During cooling mode, water may form and drip from the cool pipes and joints.■ During heating mode, water may form and drip from the heat exchanger of outdoor unit.■ During defrosting mode, water on the heat exchanger of outdoor unit evaporates and water vapor may be emitted.

CONTENTS

1. System.....	56
2. Electrical work.....	58
3. Before test run	65
4. Remote controller operation	66
5. Initial setting by remote controller	74
6. Definition of analog signal by remote controller..... (Required only for ANALOG TEMP. system)	76
7. Troubleshooting	77
8. Outlines and dimensions	89

1. System

To start, check your system type by following the flow chart below. (FTC can be used for 3 types of systems.)

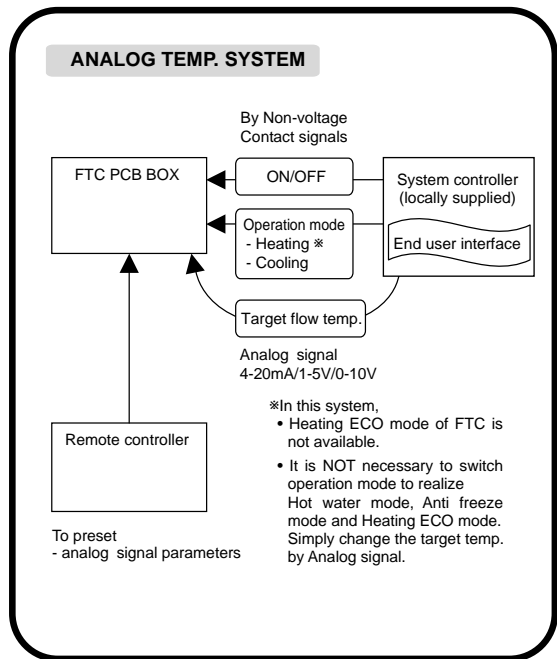
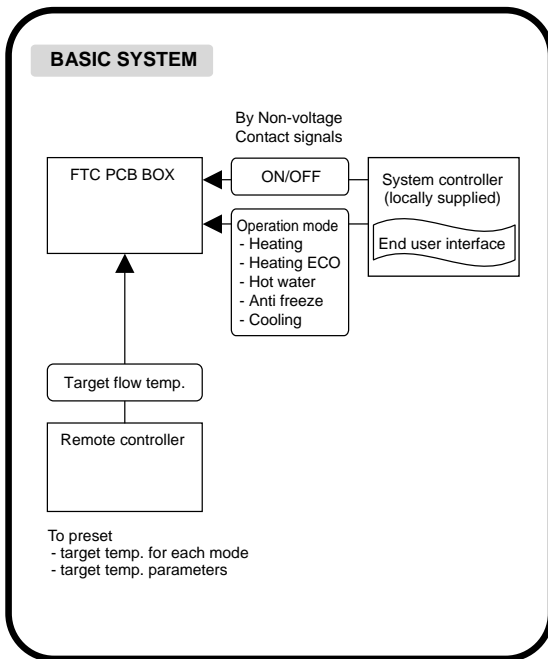
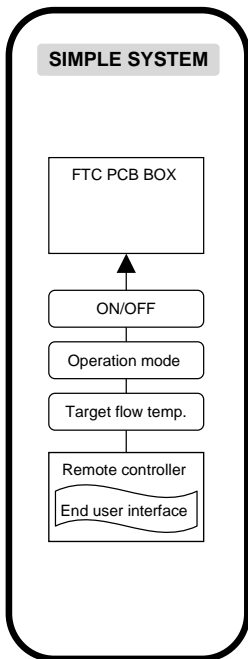
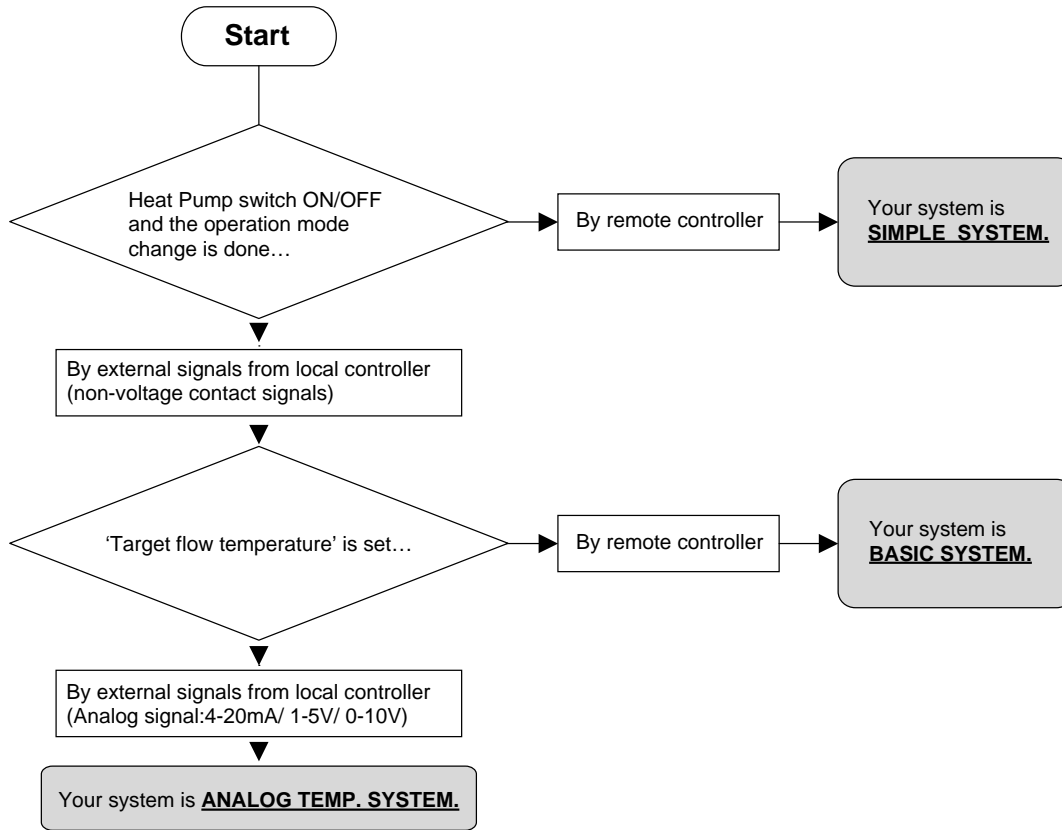

Refer to the relevant sections for details according to your system type.

System	Outdoor unit	System diagram	Power supplies	Thermistor (TH1, TH2)	Switch setting	External input	External output
BASIC	SPLIT type		2.1 2.1.1	2.2.1 2.2.2	2.2	2.5.1	2.6
			2.1 2.1.2	2.2.1 2.2.2	2.2	2.5.1	2.6
	PACKAGED type		2.1 2.1.1	2.2.1	2.2	2.5.1	2.6
			2.1 2.1.2	2.2.1	2.2	2.5.1	2.6
ANALOG TEMP.	SPLIT type		2.1 2.1.1	2.2.1 2.2.2	2.2	2.5.1 2.5.2	2.6
			2.1 2.1.2	2.2.1 2.2.2	2.2	2.5.1 2.5.2	2.6
	PACKAGED type		2.1 2.1.1	2.2.1	2.2	2.5.1 2.5.2	2.6
			2.1 2.1.2	2.2.1	2.2	2.5.1 2.5.2	2.6
SIMPLE	SPLIT type		2.1 2.1.1	2.2.1 2.2.2	2.2	—	2.6
			2.1 2.1.2	2.2.1 2.2.2	2.2	—	2.6
	PACKAGED type		2.1 2.1.1	2.2.1	2.2	—	2.6
			2.1 2.1.2	2.2.1	2.2	—	2.6

SPLIT type : the standard outdoor unit without a plate HEX(Refrigetant-water HEX) inside

PACKAGED type : the Air to Water outdoor unit with a plate HEX(Refrigetant-water HEX) inside

2. Electrical work

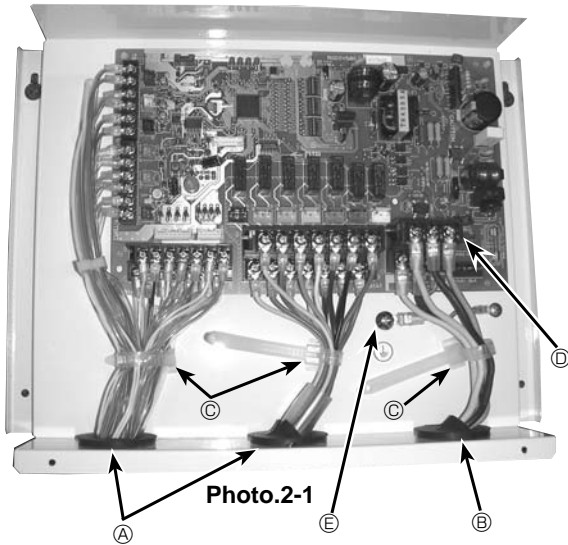

2.1. FTC (Photo. 2-1)

1. Remove the cover.
2. Wire the power cable and control cable separately through the respective wiring inlets given in the photo.

- Make sure to put screws tightly.
 - Ⓐ Inlet for control cable
 - Ⓑ Inlet for power
 - Ⓒ Clamp
 - Ⓓ FTC / Outdoor unit connecting terminals
 - Ⓔ Earth terminal

2.1.1. FTC unit power supplied from outdoor unit

The following connection patterns are available.

The outdoor unit must be powered properly. (Details are shown in its installation manual.)

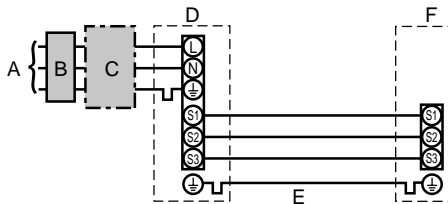

- A Outdoor unit power supply
- B Earth leakage breaker
- C Wiring circuit breaker or isolating switch
- D Outdoor unit
- E FTC unit/outdoor unit connecting cables
- F FTC unit

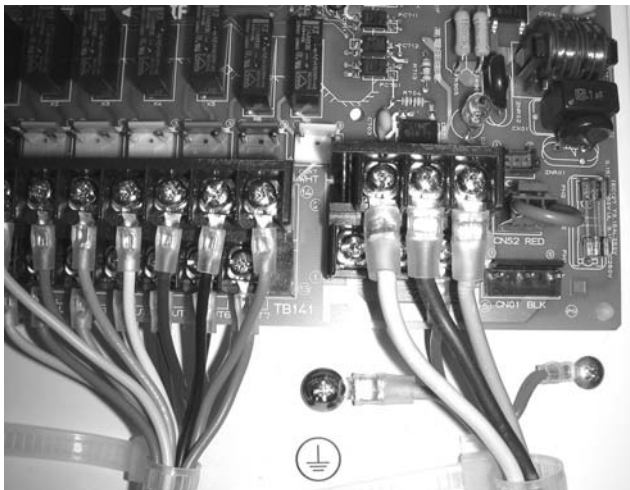
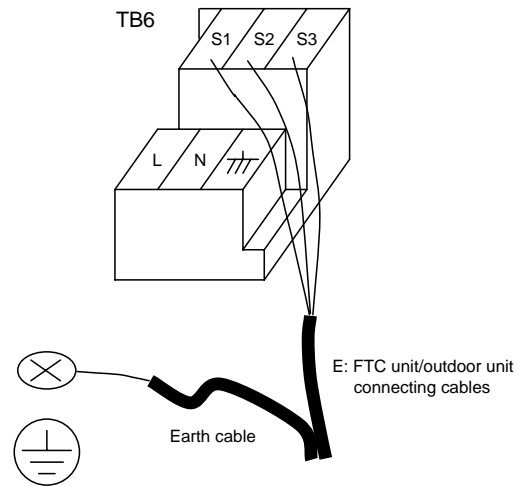

Photo.2-2



FTC unit model		PAC-IF021B-E
Wiring Wire No. × size (mm ²)	FTC unit-Outdoor unit	3× 1.5 (polar)
	FTC unit-Outdoor unit earth	1 × Min.1.5
Circuit rating	FTC unit-Outdoor unit S1-S2	AC 230 V
	FTC unit-Outdoor unit S2-S3	DC24 V

*1. Max. 80 m

*2. The figures are NOT always against the ground.

S3 terminal has DC 24 V against S2 terminal. However between S3 and S1, these terminals are not electrically insulated by the transformer or other device.

- Notes:**
1. Wiring size must comply with the applicable local and national codes.
 2. Power supply cables and FTC unit/outdoor unit connecting cables shall not be lighter than polychloroprene sheathed flexible cable. (Design 60245 IEC 57)
 3. Install an earth wire longer than other cables.

2.1.2. Separate FTC unit/outdoor unit power supplies

The following connection patterns are available.

The outdoor unit power must be powered properly (Details are shown in its installation manual).

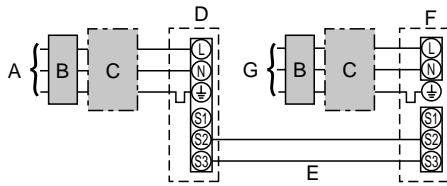

- A Outdoor unit power supply
- B Earth leakage breaker
- C Wiring circuit breaker or isolating switch
- D Outdoor unit
- E FTC unit/outdoor unit connecting cables
- F FTC unit
- G FTC unit power supply

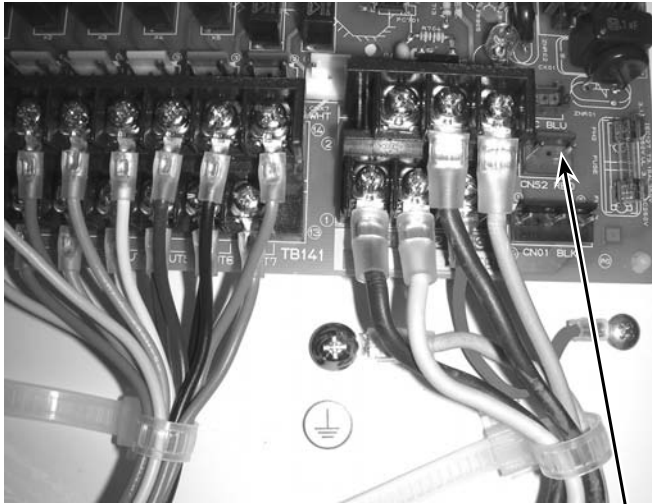
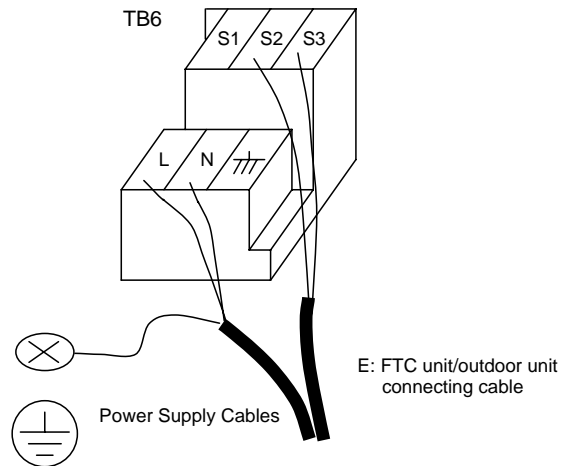

Photo.2-3

CNS2

If the FTC and outdoor units have separate power supplies, refer to the table below.

	Separate power supply specifications								
FTC unit controller connector (CNS2) connection change	Disconnected								
Outdoor unit DIP switch settings (when using separate FTC unit/outdoor unit power supplies only)	<table border="1"> <tr> <td>ON</td> <td></td> <td></td> <td>3</td> </tr> <tr> <td>OFF</td> <td>1</td> <td>2</td> <td></td> </tr> </table> (SW8) Set the SW8-3 to ON.	ON			3	OFF	1	2	
ON			3						
OFF	1	2							



FTC unit model		PAC-IF021B-E
FTC unit power supply		~/N (Single Phase), 50 Hz, 230 V
FTC unit input capacity Main switch (Breaker)		*1 16 A
Wiring Wire No. x size (mm ²)	FTC unit power supply & earth	3 x Min. 1.5
	FTC unit-Outdoor unit	*2 2 x Min. 0.3
	FTC unit-Outdoor unit earth	-
Circuit rating	FTC unit L-N	*3 AC 230 V
	FTC unit-Outdoor unit S1-S2	*3 -
	FTC unit-Outdoor unit S2-S3	*3 DC24 V

*1. A breaker with at least 3.0mm contact separation in each pole shall be provided. Use earth leakage breaker (NV).

*2. Max. 120 m

*3. The figures are NOT always against the ground.

- Notes:**
1. Wiring size must comply with the applicable local and national code.
 2. Power supply cables and FTC unit/outdoor unit connecting cables shall not be lighter than polychloroprene sheathed flexible cable. (Design 60245 IEC 57)
 3. Install an earth wire longer than other cables.

2.2. Connecting thermistor cable

Connect the thermistor 2 for the FTC controller.

2.2.1. Connecting the actual flow water temp. thermistor (TH1)

Connect the thermistor for the actual flow water temp. to 1 and 2 on the terminal block (TB61) on the FTC controller.

When the thermistor cables are too long, cut them at the appropriate length.
Do not bind them in the FTC unit.

<Thermistor position>

Put TH1 on **water** piping (water **outlet** side).

Note: Be sure to attach the TH1 where it detects Flow temp. (Water outlet side) correctly.

2.2.2. Connecting the pipe temp. thermistor (TH2)

Connect the thermistor for the refrigerant pipe temp. to 3 and 4 on the terminal block (TB61) on the FTC (PCB).

For packaged Outdoor unit : It is not necessary to connect TH2.

For split Outdoor unit : Connect TH2.

When the thermistor cables supplied with FTC are too long, cut them to the appropriate length.
Do not bind them in the FTC unit.

<Thermistor position>

Put the TH2 on **refrigerant** piping (**Liquid** side).

It is better to protect the thermistor with heat insulating materials not to be affected by the ambient temperature.

Note: Be sure to attach the TH2 where it detects Refrigerant piping temp. (Liquid side) correctly.

Caution:

Do not route the thermistor cables together with power cables.

The sensor part of the thermistor should be installed where user must not touch.

(It is separated by the supplementary insulation from where user may touch.)

<Thermistor position and necessity>

Outdoor unit	TH1	TH2	TH5
PACKAGED type	O	X	X
SPLIT type	O	O	X

O: Necessary. Connect the thermistor.

X: Not necessary. The thermistor is not needed to connect.

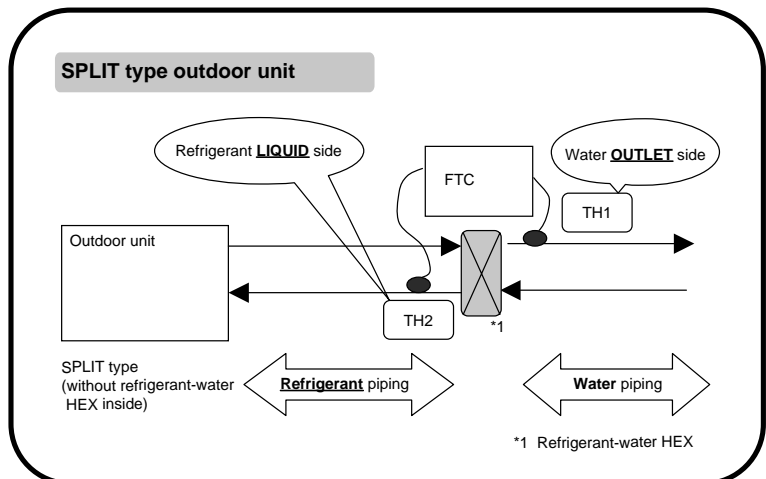
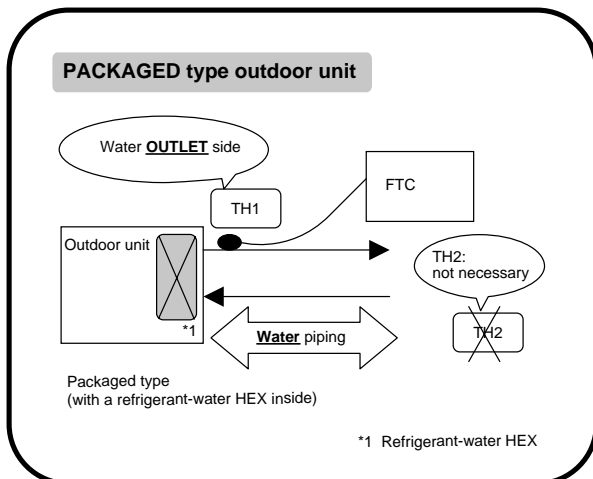

<Thermistor Characteristic graph> Refer to section 4.2 of I/F.

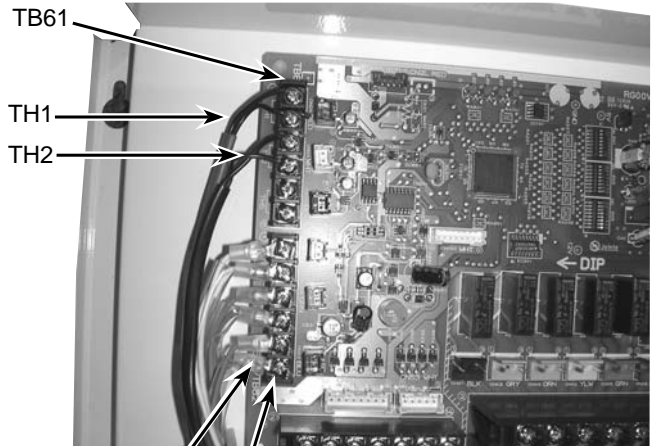

Photo.2-4

TB62
Wired remote controller cable

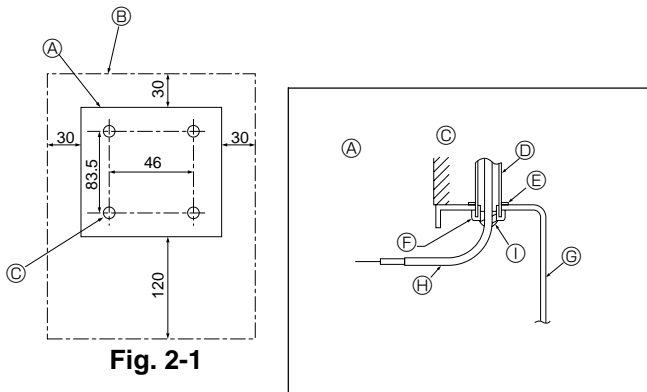

Fig. 2-1

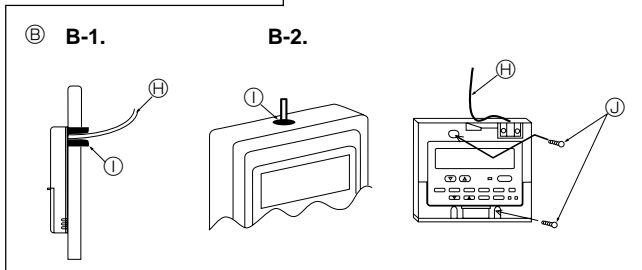

Fig. 2-2

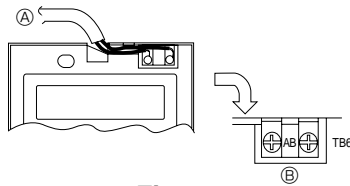

Fig. 2-3

2.3. Connecting the wired remote controller

2.3.1. Connecting the wired remote controller cable to FTC

Connect the wired remote controller cable to 5 and 6 on the terminal block (TB62) on the FTC controller. (Photo. 2-4)

Wiring wire No.xsize(mm²) : 2x0.3(Non-polar)

The 5m wire is attached as an accessory. Max. 500 m

Wiring size must comply with the applicable local and national codes.

Circuit rating: DC12V

Circuit rating is NOT always against the ground.

2.3.2. For wired remote controller

1) Installing procedures

(1) Select an installing position for the remote controller. (Fig. 2-1)

► Procure the following parts locally:

2 piece switch box

Thin copper conduit tube

Lock nuts and bushings

[Fig.2-1]

Ⓐ Remote controller profile

Ⓑ Required clearances surrounding the remote controller

Ⓒ Installation pitch

(2) Seal the service entrance for the remote controller cable with putty to prevent possible invasion of dew drops, water, cockroaches or insects. (Fig. 2-2)

Ⓐ For installation in the switch box

Ⓑ For direct installation on the wall, select one of the followings:

- Prepare a hole through the wall to pass the remote controller cable (in order to take out the remote controller cable from the back), then seal the hole with putty.

- Take out the remote controller cable through the cut-out upper case, then seal the cut-out notch with putty.

B-1. To lead the remote controller cable from the back of the controller

B-2. To take out the remote controller cable through the upper portion

[Fig.2-2]

Ⓒ Wall Ⓔ Switch box

Ⓓ Conduit Ⓕ Remote controller cable

Ⓔ Lock nut Ⓖ Seal with putty

Ⓕ Bushing Ⓖ Wood screw

2) Connecting procedures (Fig. 2-3)

① Connect the remote controller cable to the terminal block.

Ⓐ To TB62 No.5 and 6 on the FTC unit

Ⓑ TB6 (No polarity)

2.4. Switch setting of FTC

Set the dip switch on the FTC (PCB) according to the following table.

System	ON/OFF Input	Change mode Input	Change TEMP. Input	Outdoor unit *4	SW1-1	SW1-2	SW1-5	SW1-6	SW6-1	SW6-2
BASIC	External input (non-voltage contact)	External input (non-voltage contact)	DIP switch on PCB SW2-1~8, SW3-1~3	SPLIT type	ON	OFF	OFF	ON	OFF	OFF
				PACKAGED type	ON	OFF	ON	ON	OFF	OFF
	External input (non-voltage contact)	External input (non-voltage contact)	Wired remote controller	SPLIT type	ON	OFF	OFF	OFF	OFF	OFF
				PACKAGED type	ON	OFF	ON	OFF	OFF	OFF
ANALOG TEMP.	External input or 4-20mA *1	External input (non-voltage contact)	4-20mA	SPLIT type	OFF	ON	OFF	OFF	ON	ON
				PACKAGED type	OFF	ON	ON	OFF	ON	ON
	External input or 1-5V *2	External input (non-voltage contact)	1-5V	SPLIT type	OFF	ON	OFF	OFF	OFF	ON
				PACKAGED type	OFF	ON	ON	OFF	OFF	ON
External input	External input (non-voltage contact)	0-10V	SPLIT type	ON	ON	OFF	OFF	OFF	OFF	
			PACKAGED type	ON	ON	ON	OFF	OFF	OFF	
BASIC and SIMPLE	External input and Wired remote controller *3	External input and Wired remote controller *3	DIP switch on PCB SW2-1~8, SW3-1~3	SPLIT type	OFF	OFF	OFF	ON	OFF	OFF
				PACKAGED type	OFF	OFF	ON	ON	OFF	OFF
	External input and Wired remote controller *3	External input and Wired remote controller *3	Wired remote controller	SPLIT type	OFF	OFF	OFF	OFF	OFF	OFF
				PACKAGED type	OFF	OFF	ON	OFF	OFF	OFF
SIMPLE	Wired remote controller	Wired remote controller	Wired remote controller	SPLIT type	OFF	OFF	OFF	OFF	OFF	OFF
				PACKAGED type	OFF	OFF	ON	OFF	OFF	OFF

*1: 4-20mA...OFF: 0~2mA

*2: 1-5V...OFF: 0~0.5V

*3: The command from the external input is prior to the one from the wired remote controller.

*4: SPLIT type : the standard outdoor unit without a plate HEX(refrigerant-water) inside.

PACKAGED type : the Air to Water outdoor unit with a plate of HEX(refrigerant-water) inside

OTHER SWITCH SETTING

SW1-3 Prohibition of Cooling mode

SW1-3=OFF : Operation mode Heating/HeatingECO/HotWater/Anti-freeze/Cooling

SW1-3=ON : Operation mode Heating/HeatingECO/HotWater/Anti-freeze

SW1-4 SW3-4,5,8 Not in use. Set to OFF. (Initial setting)

SW3-7 Not in use. Set to ON. (Initial setting)

SW3-6 Logic of Forced Comp. OFF external signal(TB142 5-6)

SW3-6	TB142 No.5-6 input	Item
OFF	OFF(open)	Normal
	ON(short)	Forced Comp. OFF
ON	OFF(open)	Forced Comp. OFF
	ON(short)	Normal

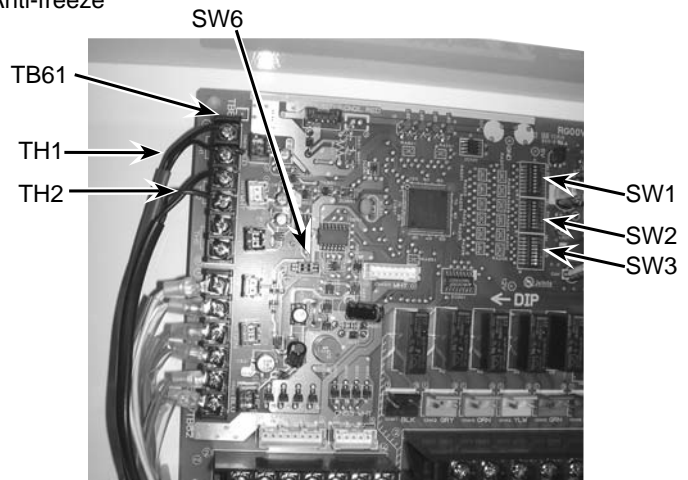

Photo-2-5

SW1-6,7,8 Set temperature range

SW1-6=OFF Set temperature range with wired remote controller

SW1-6=ON Set temperature table with DIP switch of FTC

SW1-6	SW1-7	SW1-8	Temperature range with wired remote controller			Temperature table SW2-1~8, SW3-1~3
			Heating/HeatingECO/Hot Water	Anti-Freeze	Cooling	
OFF	OFF	OFF	Upper 55 °C / lower 20 °C	Upper 45 °C / lower 5 °C	Upper 25 °C / lower 5 °C	—
OFF	ON	OFF	Upper 60 °C / lower 20 °C *1	Upper 45 °C / lower 5 °C	Upper 25 °C / lower 5 °C	—
OFF	OFF	ON	Upper 50 °C / lower 20 °C	Upper 45 °C / lower 5 °C	Upper 25 °C / lower 5 °C	—
OFF	ON	ON	—	—	—	—
ON	OFF	OFF	—	—	—	Table①
ON	ON	OFF	—	—	—	Table②
ON	OFF	ON	—	—	—	—
ON	ON	ON	—	—	—	—

*1. Don't use this setting when you use the standard outdoor unit without a plate HEX(Refrigerant-water) inside.

SW2-1~8 SW3-1~3 Fixed set temperature with DIP switch of FTC (Available when SW1-6 is ON)
 SW2-1~3 Fixed set temperature for Heating mode (Table①~② depends on SW1-7,8.)

SW2-1	SW2-2	SW2-3	Table①	Table②
OFF	OFF	OFF	25 °C	25 °C
ON	OFF	OFF	30 °C	30 °C
OFF	ON	OFF	35 °C	35 °C
ON	ON	OFF	40 °C	40 °C
OFF	OFF	ON	45 °C	45 °C
ON	OFF	ON	50 °C	50 °C
OFF	ON	ON	55 °C	55 °C
ON	ON	ON	60 °C *1	60 °C *1

The selectable temperature range for Heating mode depends on outdoor unit type.

*1 Do not use this setting when you use the standard outdoor unit without a plate HEX(refrigerant-water) inside.

SW2-4~6 Fixed set temperature for Hot Water mode (Table①~② depends on SW1-7,8.)

SW2-4	SW2-5	SW2-6	Table①	Table②
OFF	OFF	OFF	46 °C	25 °C
ON	OFF	OFF	48 °C	30 °C
OFF	ON	OFF	50 °C	35 °C
ON	ON	OFF	52 °C	40 °C
OFF	OFF	ON	54 °C	45 °C
ON	OFF	ON	56 °C	50 °C
OFF	ON	ON	58 °C	55 °C
ON	ON	ON	60 °C *1	60 °C *1

The selectable temperature range for Hot Water mode depends on outdoor unit type.

*1 Do not use this setting when you use the standard outdoor unit without a plate HEX(refrigerant-water) inside.

SW2-7,8 Fixed set temperature for Anti-freeze mode (Table①~② depends on SW1-7,8.)

SW2-7	SW2-8	Table①	Table②
OFF	OFF	5 °C	5 °C
ON	OFF	10 °C	10 °C
OFF	ON	15 °C	15 °C
ON	ON	20 °C	20 °C

SW3-1~3 Fixed set temperature for Cooling mode (Table①~② depends on SW1-7,8.)

SW3-1	SW3-2	SW3-3	Table①	Table②
OFF	OFF	OFF	7 °C	7 °C
ON	OFF	OFF	10 °C	10 °C
OFF	ON	OFF	12 °C	12 °C
ON	ON	OFF	15 °C	15 °C
OFF	OFF	ON	18 °C	18 °C
ON	OFF	ON	20 °C	20 °C
OFF	ON	ON	22 °C	22 °C
ON	ON	ON	25 °C	25 °C

2.5. Connecting external input

FTC can be operated by following external input.

2.5.1 EXTERNAL INPUT (Contact signal)

TB142	OFF	ON	Remark
1-2 (IN1)	—	—	Not in use
3-4 (IN2)	—	—	Not in use
5-6 (IN3)	Normal	Forced Comp. OFF	SW3-6=OFF
	Forced Comp. OFF	Normal	SW3-6=ON
7-8 (IN4)	OFF	Cooling	
10-11 (COM-IN5)	OFF	Heating	
10-12 (COM-IN6)	OFF	Heating ECO *1	
10-13 (COM-IN7)	OFF	Hot Water	
10-14 (COM-IN8)	OFF	Anti-Freeze	

*1 Heating ECO mode sets the set temperature depending on the outdoor temperature.

TB142

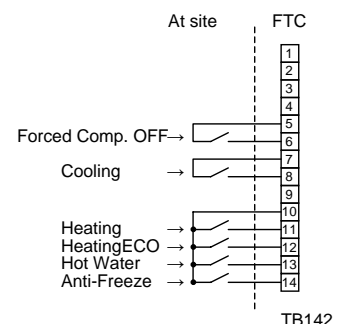
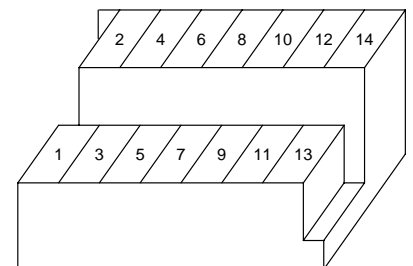

2.7. Wiring specification of External output / External input

Locally supplied parts

Item	Name	Model and specifications
External output function	External output signal wire	Use sheathed vinyl coated cord or cable. Max. 50m Wire type : CV, CVS or equivalent Wire size : Stranded wire 0.5mm ² to 1.25mm ² Solid wire: ϕ 0.65mm to ϕ 1.2mm
	Display lamp, etc.	Non-voltage Contact AC220-240V (DC30V), 1A or less *Connect the surge absorber according to the load at site.
External input function	External input signal wire	Use sheathed vinyl coated cord or cable. Max. 10m Wire type : CV, CVS or equivalent Wire size : Stranded wire 0.5mm ² to 1.25mm ² Solid wire : ϕ 0.65mm to ϕ 1.2mm
	Switch	Non-voltage "a" contact signals Remote switch : minimum applicable load DC 12V, 1mA

3. Before test run

3.1. Check

After completing installation and the wiring and piping of the local application and outdoor units, check for refrigerant leakage, looseness in the power supply or control wiring, wrong polarity, and no disconnection of one phase in the supply. Use a 500-volt megohmmeter to check that the resistance between the power supply terminals and ground is at least 1.0M Ω .

Warning:

Do not use the system if the insulation resistance is less than 1.0M Ω .

Caution:

Do not carry out this test on the control wiring (low voltage circuit) terminals.

3.2. Self-check

- ① Turn on the power.
- ② Press [CHECK] button twice.
- ③ Press [CHECK] button twice to finish self-check.

ⒶCHECK button ⒷIC : FTC unit Ⓒ : Outdoor unit ⒹCheck code

Check code	Symptom
P1	Flow water (TH1) sensor error
P2	Refrigerant liquid Pipe (TH2) sensor error
P6	Freezing/Overheating protection operation
Fb	FTC unit control system error (memory error, etc.)
E0~E5	Signal transmission failure between remote controller and FTC.
E6~EF	Signal transmission failure between outdoor unit and FTC.
----	No trouble generated in the past.
FFFF	No corresponding unit
U*, F*	Outdoor unit failure. Refer to the outdoor unit wiring diagram.

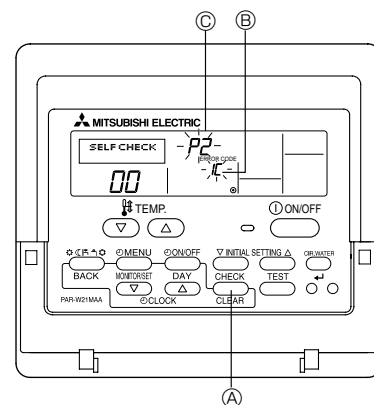

For description of each LED(LED1~5) provided on the FTC, refer to the following table.

LED 1 (Power for microcomputer)	Indicates whether control power is supplied. Make sure that this LED is always lit.
LED 2 (Power for remote controller)	Indicates whether power is supplied to the remote controller. This LED lights only in the case of the FTC unit which is connected to the outdoor unit refrigerant address "0".
LED 3 (Communication between FTC and outdoor unit)	Indicates state of communication between the FTC and outdoor unit. Make sure that this LED is always blinking.
LED 4	—
LED 5	—

4. Remote controller operation

4.1 Parts name

■ Wired Remote-Controller

Display Section

For purposes of this explanation, all parts of the display are shown. During actual operation, only the relevant items will be displayed.

Identifies the current operation

Shows the operating mode, etc.
* Multi language display is supported.

“Centrally Controlled” indicator

Indicates that operation of the remote controller has been prohibited by a master controller.

“Timer is Off” indicator

Indicates that the timer is off.

Temperature Setting

Shows the target temperature.

Day-of-Week

Shows the current day of the week.

Time/Timer Display

Shows the current time, unless the simple or Auto Off timer is set.
If the simple or Auto Off timer is set, shows the time remaining.

ON/OFF indicator

Indicates if timer is set ON/OFF.

“Locked” indicator

Indicates that remote controller buttons have been locked.

Timer indicators

The indicator comes on if the corresponding timer is set.

Error indicator

Comes on when error occurs.

Temperature indicator

Shows the current water temperature.

●(Power On indicator)

Indicates that the power is on.

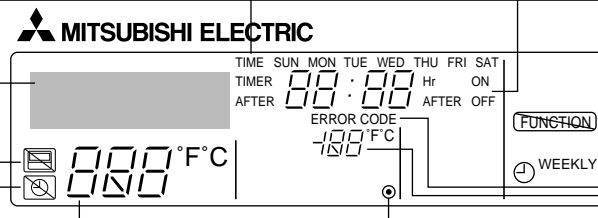

Operation Section

Set Temperature buttons

- ▽ Down
- △ Up

Timer Menu button (Monitor/Set button)

Mode button (Return button)

Set Time buttons

- ▽ Back
- △ Ahead

Timer On/Off button (Set Day button)

ON/OFF button

Setting change button

CIR. WATER button (<Enter> button)

Not available

(TEST run function is not available with this FTC unit.)

Self check(Clear) button

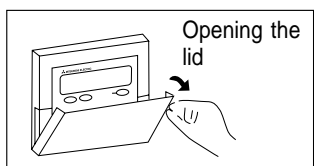
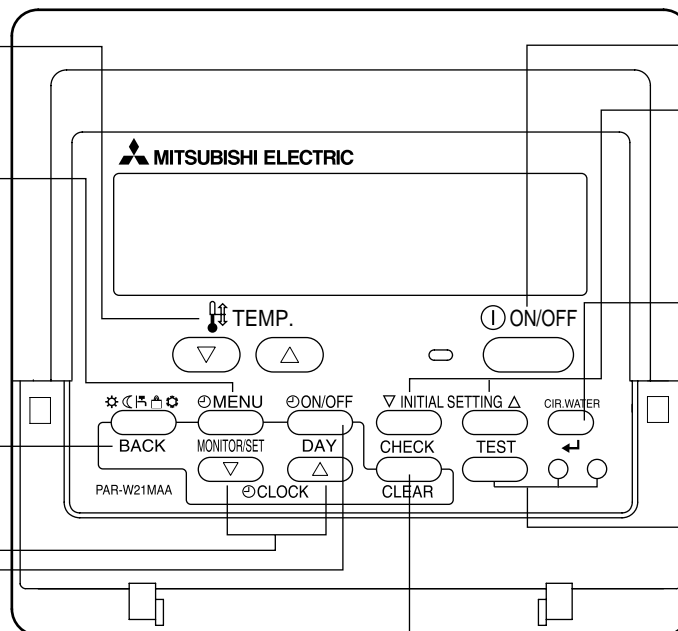

Note:

- “PLEASE WAIT” message
This message is displayed for approximately 3 minutes when power is supplied to the FTC unit or when the unit is recovering from a power failure.
- “NOT AVAILABLE” message
This message is displayed if a button is pressed to operate a function that the FTC unit does not have, or a function that is not available due to the setting.

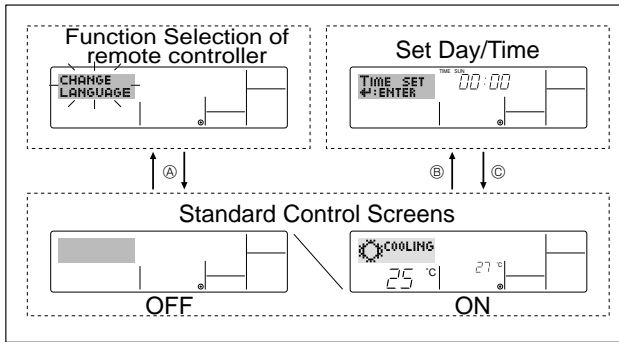

<Screen configuration>

For details on setting the language for the remote controller display, refer to 4.6. Function Selection. The initial language setting is English.

- **Function Selection of remote controller:** Set the functions and ranges available to the remote controller (timer functions, operating restrictions, etc.)
- **Set Day/Time:** Set the current day of the week or time.
- **Standard Control Screens:** View and set the air conditioning system's operating status

<How to change the screen>

- (A) : Hold down both the Mode button (2) and the Timer On/Off button (9) for 2 seconds.
- (B) : Press either of the Set Time buttons (▽ or △) (11).
- (C) : Press the Mode button (2).

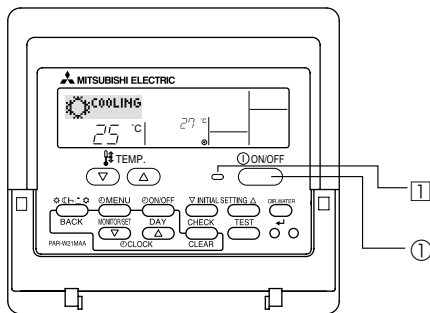
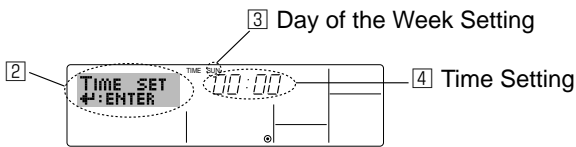
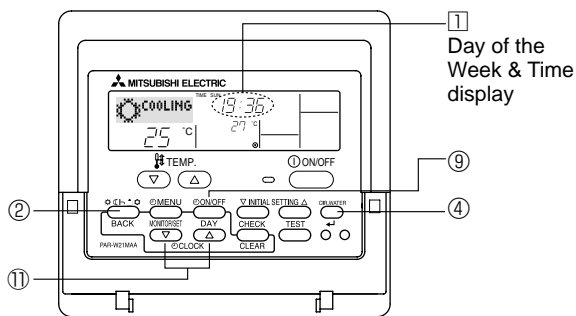

4.2 Setting the day of the week and time

- Press the ▽ or △ Set Time button (11) to show display (2).
- Press the Timer On/Off (Set Day) button (9) to set the day.
 - * Each press advances the day shown at (3) : Sun → Mon → ... → Fri → Sat.
- Press the appropriate Set Time button (11) as necessary to set the time.
 - * As you hold the button down, the time (at (4)) will increment first in one-minute intervals, then in ten-minute intervals, and then in 1-hour intervals.
- After making the appropriate settings at Steps 2 and 3, press the ↵ button (4) to lock in the values.

Note:

The day and time will not appear if clock use has been disabled at Function Selection of remote controller.

4.3 Operation

Available items are different depending on your system. (Refer to section 3.)

4.3.1 Switching

<To Start Operation>

- Press the ON/OFF button (1).
 - The ON lamp (1) and the display area come on.

Note:

When the unit restarts, the previous settings are recalled as follows.

	Remote controller setting
Mode	Last operation mode
Temperature setting	Last set temperature

<To Stop Operation>

- Press the ON/OFF button (1) again.
 - The ON lamp (1) and the display area go dark.

Note:

Even if you press the ON/OFF button to restart the system while turning down the operation, the outdoor unit will not start for about 3 minutes.

This is to prevent the internal components from being damaged.

4.3.2. Mode select

Press operation mode (⊛⊞⊟⊠⊡) button ② and select operation mode.

- ▶ ⊛ Heating mode (Space heating)
- ▶ ⊞ Heating ECO mode (Space heating with weather compensation *1)
- ▶ ⊟ Hot water mode (Sanitary hot water)
- ▶ ⊠ Anti freeze mode (Heating to prevent water pipe from freezing)
- ▶ ⊡ Cooling mode (Space cooling)

*1 Target flow temp. varies according to the outdoor temperature. (Refer to 5. for setting.)

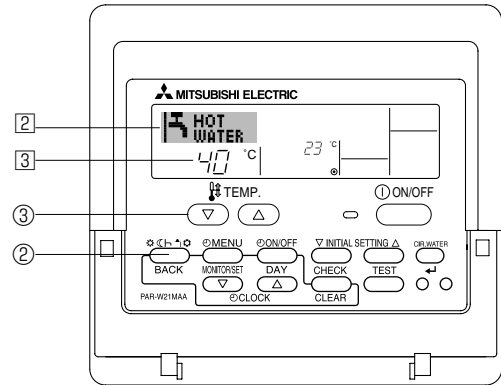

4.3.3. Temperature setting

▶ To decrease the target temperature:

Press (▽) button ③ to set the desired temperature. The selected temperature is displayed ③.

▶ To increase the target temperature:

Press (△) button ③ to set the desired temperature. The selected temperature is displayed ③.

Note: Heating ECO mode sets the set temperature depending on the outdoor temperature.

4.4. Other Functions

4.4.1. Locking the Remote Controller Buttons (Operation function limit)

■ If you wish, you can lock the remote controller buttons. You can use the Function Selection of remote controller to select which type of lock to use.

(For information about the lock type, refer to 4.5, item[2].)

Specifically, you can use either of the following 2 lock types.

- ① Lock All Buttons: Locks all of the buttons on the remote controller.
- ② Lock All Except ON/OFF: Locks all buttons other than the ON/OFF button.

Note: The “Locked” indicator appears on the screen to indicate that buttons are currently locked.

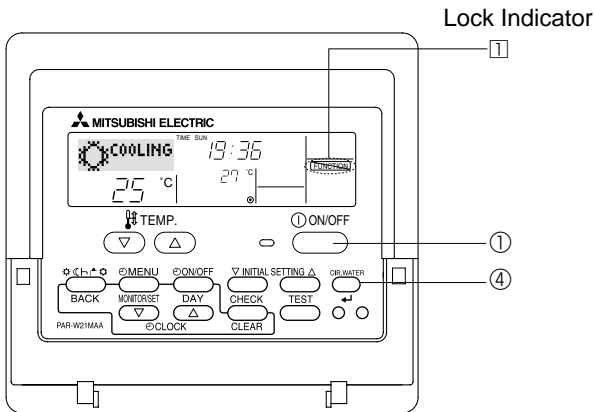

<How to Lock the Buttons>

1. While holding down the CIR. WATER button ④, press and hold down the ON/OFF button ① for 2 seconds. The “Locked” indication appears on the screen (at ①), indicating that the lock is now engaged.

* If locking has been disabled in Function Selection of remote controller, the screen will display the “Not Available” message when you press the buttons as described above.

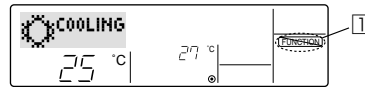

- If you press a locked button, the “Locked” indication (at ①) will blink on the display.

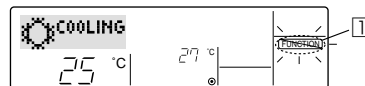

<How to Unlock the Buttons>

1. While holding down the CIR. WATER button ④, press and hold down the ON/OFF button ① for 2 seconds—so that the “Locked” indication disappears from the screen (at ①).

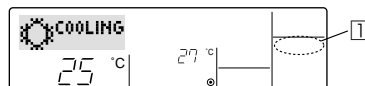

4.4.2. Error Codes indication

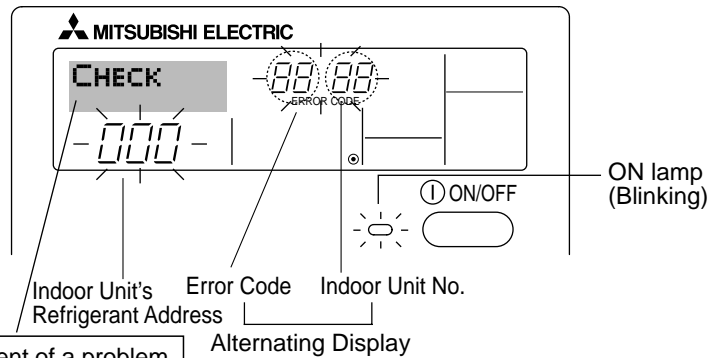

If you have entered contact number to be called in the event of a problem, the screen displays this number. (You can set this up under Function Selection of remote controller. For information, refer to 4.5.)

- If the ON lamp and error code are both blinking: This means that the air conditioner is out of order and operation has been stopped (and cannot resume). Take note of the indicated unit number and error code, then switch off the power to the air conditioner and call your dealer or servicer.

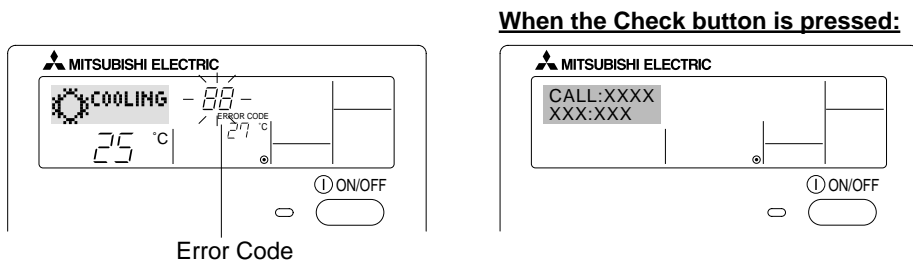

- If only the error code is blinking (while the ON lamp remains lit): Operation is continuing, but there may be a problem with the system. In this case, you should note down the error code and then call your dealer or servicer for advice.
- * If you have entered contact number to be called in the event of a problem, push the Check button to display it on the screen. (You can set this up under Function Selection of remote controller. For information, refer to 4.5.)

4.5. Function Selection

Various remote controller functions are selectable in the remote controller function selection mode. Change setting when needed.

Item 1	Item 2	Item 3
1. Change language ("CHANGE LANGUAGE")	Language setting to display	• Some European languages are selectable.
2. Function limit ("FUNCTION SELECTION")	(1) Operation function limit setting (operation lock) ("LOCKING FUNCTION")	• To invalidate some functions.
	(2) Use of operation mode setting ("SELECT MODE")	• Setting the use or non-use of operation mode
	(3) Temperature range limit setting ("LIMIT TEMP FUNCTION")	• Setting the temperature adjustable range (maximum, minimum)
3. Mode selection ("MODE SELECTION")	(1) Remote controller main/sub setting ("CONTROLLER MAIN/SUB")	• Selecting main or sub remote controller * When 2 remote controllers are connected to 1 group, 1 controller must be set to sub.
	(2) Use of clock setting ("CLOCK")	• To select the use or non-use of clock function
	(3) Timer function setting ("TIMER MODE")	• To select the timer type
	(4) Contact number setting in case of fault ("CALL.")	• Contact number display in case of error • To select the telephone number
	(5) Temperature offset setting ("TEMP OFFSET FUNCTION")	• To select the use or non-use of the water temperature offset function
4. Display change ("DISP MODE SETTING")	(1) Temperature display °C/°F setting ("TEMP MODE °C/°F")	• To select the temperature unit (°C or °F) to display
	(2) Water temperature display setting ("WATER TEMP. DISP. SELECT")	• To select the use or non-use of the display of "actual flow water temperature"

[Function selection flow chart]
Setting language(English)

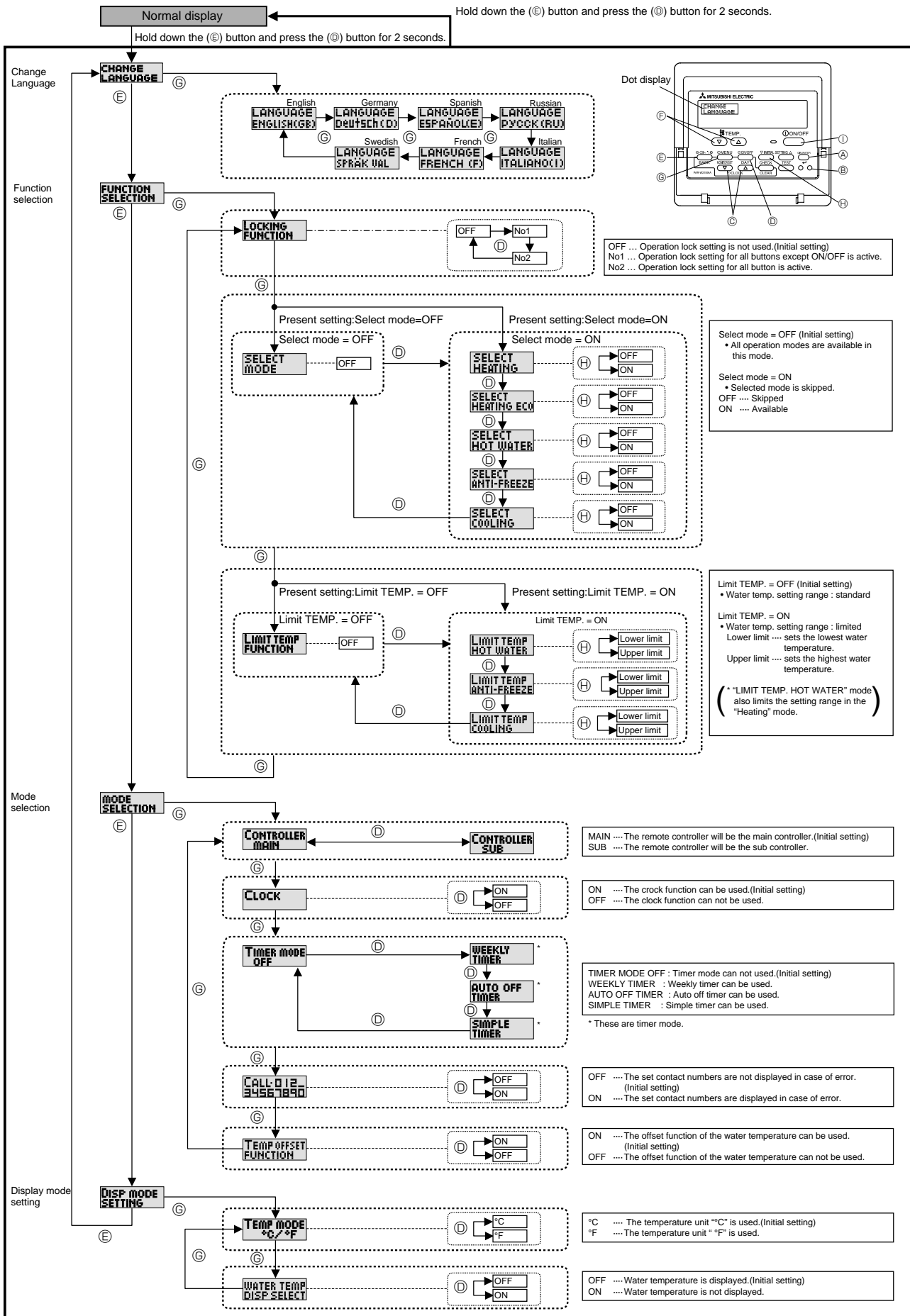

[Detailed setting]

[4]-1 CHANGE LANGUAGE setting

The language that appears on the dot display can be selected.

- Press the [⊕ MENU] button ③ to change the language.
 - ① English (GB), ② German (D), ③ Spanish (E), ④ Russian (RU),
 - ⑤ Italian (I), ⑥ French (F), ⑦ Swedish (SW)

Refer to the dot display table.

[4]-2 Function selection setting

(1) Operation function limit setting (operation lock)

- To switch the setting, press the [⊕ ON/OFF] button ①.
 - ① no1: Operation lock setting is made on all buttons other than the [⊕ ON/OFF] button ①.
 - ② no2: Operation lock setting is made on all buttons.
 - ③ OFF (Initial setting value): Operation lock setting is not made.

* To make the operation lock setting valid on the normal screen, it is necessary to press buttons (Press and hold down the [CIR.WATER] ④ and [⊕ ON/OFF] buttons ① at the same time for 2 seconds.) on the normal screen after the above setting is made.

(2) Use of operation mode setting

When the remote controller is connected to the unit that has the operation mode, the following settings can be made.

- To switch the setting, press the [⊕ ON/OFF] button ①.
 - ① SELECT HEATING
ON:HEATING mode can be selected.
OFF....HEATING mode is skipped.
 - ② SELECT HEATING ECO
ON:HEATING ECO mode can be selected.
OFF....HEATING ECO mode is skipped.
 - ③ SELECT HOT WATER
ON:HOT WATER mode can be selected.
OFF....HOT WATER mode is skipped.
 - ④ SELECT ANTI-FREEZE
ON:ANTI-FREEZE mode can be selected.
OFF....ANTI-FREEZE mode is skipped.
 - ⑤ SELECT COOLING
ON:COOLING mode can be selected.
OFF....COOLING mode is skipped.
 - ⑥ SELECT MODE OFF(Initial setting value)
The all operation mode is displayed when the mode is selected.

(3) Temperature range limit setting

After this setting is made, the temperature can be changed within the set range.

- To switch the setting, press the [⊕ ON/OFF] button ①.
 - ① LIMIT TEMP HOT WATER MODE:
The temperature range can be changed on hot water / heating mode.
 - ② LIMIT TEMP ANTI-FREEZE MODE:
The temperature range can be changed on anti-freeze mode.
 - ③ LIMIT TEMP COOLING MODE:
The temperature range can be changed on cooling mode.
 - ④ OFF (initial setting): The temperature range limit is not active.

* When the setting other than OFF is made, the temperature range limit setting on heating, hot water, anti-freeze, and cooling mode is made at the same time. However, the range cannot be limited when the set temperature range has not changed.
 - To increase or decrease the temperature, press the [⏴ TEMP. (▽) or (△)] button ②.
 - To switch the upper limit setting and the lower limit setting, press the [▽ INITIAL SETTING] button ③. The selected setting will blink and the temperature can be set.

[4]-3 Mode selection setting

(1) Remote controller main/sub setting

- To switch the setting, press the [⊕ ON/OFF] button ①.
 - ① Main: The controller will be the main controller.
 - ② Sub: The controller will be the sub controller.

(2) Use of clock setting

- To switch the setting, press the [⊕ ON/OFF] button ①.
 - ① ON: The clock function can be used.
 - ② OFF: The clock function cannot be used.

(3) Timer function setting

- To switch the setting, press the [⊕ ON/OFF] button ① (Choose one of the followings.).
 - ① WEEKLY TIMER:
The weekly timer can be used.
 - ② AUTO OFF TIMER:
The auto off timer can be used.
 - ③ SIMPLE TIMER:
The simple timer can be used.
 - ④ TIMER MODE OFF(Initial setting):
The timer mode cannot be used.

* When the use of clock setting is OFF, the "WEEKLY TIMER" cannot be used.

(4) Contact number setting for error situation

- To switch the setting, press the [⊕ ON/OFF] button ①.
 - ① CALL OFF:
The set contact numbers are not displayed in case of error.
 - ② CALL **** * * * * *:
The set contact numbers are displayed in case of error.
CALL_:
The contact number can be set when the display is as shown above.
 - Setting the contact numbers
To set the contact numbers, follow the following procedures.
Move the blinking cursor to set numbers. Press the [⏴ TEMP. (▽) and (△)] button ② to move the cursor to the right (left). Press the [⊕ CLOCK (▽) and (△)] button ③ to set the numbers.

(5) Use of water temperature offset function

- To switch the setting, press the [⊕ ON/OFF] button ①.
 - ① ON: The water temperature offset function can be used.
 - ② OFF: The water temperature offset function cannot be used.

* Refer to page 23 for details of offset function.

[4]-4 Display change setting

(1) Temperature display °C/°F setting

- To switch the setting, press the [⊕ ON/OFF] button ①.
 - ① °C: The temperature unit °C is used.
 - ② °F: The temperature unit °F is used.

(2) Water temperature display setting

- To switch the setting, press the [⊕ ON/OFF] button ①.
 - ① ON: Water temperature is displayed.
 - ② OFF: Water temperature is not displayed.

[Dot display table]

Selecting language		English	German	Spanish	Russian	Italian	French	Swedish
Waiting for start-up		PLEASE WAIT	←	←	←	←	←	←
Operation mode	Heating	HEATING	HEIZEN	CALOR	НАГРЕВ	RISCALD.	CHAUD	VÄRME DRIFT
	Heating ECO	HEATING ECO	HEIZEN ECO	CALOR ECO	НАГРЕВ ЭКОНОМ	RISCALD. ECO	CHAUFF. ECO	VÄRME ECO
	Hot water	HOT WATER	BRAUCH-H2O	AGUA CALIENTE	ГОРЯЧАЯ ВОДА	ACQUA C. SANIT.	EAU CHAUDE	VÄRM VATTEN
	Anti-freeze	ANTI-FREEZE	FROST-SCHUTZ	ANTI-CONGEL.	АНТИ-ФРИЗ	ANTI GELO	ANTI GIVRE	FRYS SKYDD
	Cooling	COOLING	KÜHLEN	FRIO	ОХЛАЖДЕНИЕ	RAFFREDD.	FROID	KYL DRIFT
	Stand by (Hot adjust)	STAND BY	STAND BY	CALENTANDO	ОБОГРЕВ: ПАУЗА	STAND BY	PRE CHAUFFAGE	STAND BY
	Defrost	DEFROST	Abtauen	DESCONGE-LACIÓN	ОТТАВЛИВАНИЕ	SBRINA MENTO	DEGIVRAGE	AVFROST
Not use button		NOT AVAILABLE	Nicht Verfügbar	NO DISPONIBLE	НЕ ДОСТУПНО	NON DISPONIBILE	NON DISPONIBLE	FINNS EJ
Check (Error)		CHECK	Prüfen	COMPROBAR	ПРОВЕРКА	CHECK	CONTROLE	PLEASE WAIT
Test run		TEST RUN	Testbetrieb	TEST FUNCIONAMIENTO	ТЕСТОВЫЙ ЗАПУСК	TEST RUN	TEST	CHANGE LANGUAGE
Self check		SELF CHECK	Selbst-diagnose	AUTO REVISIÓN	САМОДИАГНОСТИКА	SELF CHECK	AUTO CONTROLE	LANGUAGE SPRÅK VAL
Change language		CHANGE LANGUAGE	←	←	←	←	←	←
Language selection		LANGUAGE ENGLISH(E)	LANGUAGE DEUTSCH (D)	LANGUAGE ESPAÑOL(E)	LANGUAGE РУССКОЕ (RU)	LANGUAGE ITALIANO(I)	LANGUAGE FRENCH (F)	LANGUAGE SPRÅK VAL
Display change		DISP MODE SETTING	Anzeige Betriebsart	MOstrar MODo	НАСТРОЙКА ИЛИ РЕЖИМА	IMPOSTAZIONE MODO DISPLAY	AFFICHAGE SOUS MENU	DISPLAY LÅGE VAL
Temperature display °C/°F setting		TEMP MODE °C/°F	Wechsel °C/°F	TEMPERADOS °C/°F	ЕДИН.ТЕМП. °C/°F	TEMPERATURA °C/°F	TEMPERATURE °C/°F	VAL AV TEMP MODE °C/°F
Water temperature display setting		WATER TEMP DISP SELECT	H2O-TEMP. DISP WAHL	VISUALIZAR TEMP. AGUA	ИНАДИКАЦИЯ °° ВОДЫ	VISUALIZZA TEMP. ACQUA	AFFICHAGE TEMP EAU	VATTEN TEMP DISPLAYVAL
Function selection		FUNCTION SELECTION	Funktion auswählen	SELECCIÓN DE FUNCIONES	ВЫБОР ФУНКЦИИ	SELEZIONE FUNZIONI	SELECTION FONCTIONS	DRIFT VAL
Operation function limit setting		LOCKING FUNCTION	Sperre - Funktion	FUNCION BLOQUEADA	ФУНКЦИЯ БЛОКИРОВКИ	BLOCCO FUNZIONI	BLOCCAGE FONCTIONS	DRIFT LÅS

Selecting language		English	German	Spanish	Russian	Italian	French	Swedish
Mode skip setting		SELECT MODE	AUSWAHL BETRIEBSART	ELEGIR MODO	УДАЛИТЬ РЕЖИМ	PROIBIZIONE MODO	SELECTION MODE INACTIF	DRIFT VAL MODE
Mode skip	Heating	SELECT HEATING	AUSWAHL HEIZEN	ELEGIR MODO CALOR	УДАЛИТЬ: НАГРЕВ	PROIBIZIONE RISCALD.	CHAUFFAGE INACTIF	VAL VÄRMEDRIFT
	Heating ECO	SELECT HEATING ECO	AUSWAHL HEIZEN-ECO	ELEGIR CALOR ECO	УДАЛИТЬ: НАГРЕВ ЭКОНОМ	PROIBIZIONE RISCALD. ECO	CHAUFFAGE ECO INACTIF	VAL VÄRME ECO
	Hot water	SELECT HOT WATER	AUSWAHL BRAUCH-H2O	ELEGIR AGUA CALIEN.	УДАЛИТЬ: ГОРЯЧ. ВОДА	PROIBIZIONE ACQUA SAN.	EAU CHAUDE INACTIVE	VAL VÄRMVATTEN
	Anti-freeze	SELECT ANTI-FREEZE	AUSWAHL FROST-SCHUTZ	ELEGIR ANTI-CONGEL.	УДАЛИТЬ: АНТИ-ФРИЗ	PROIBIZIONE ANTIGELO	ANTI GIVRE INACTIF	VAL FRYS SKYDD
	Cooling	SELECT COOLING	AUSWAHL KÜHLEN	ELEGIR MODO FRIO	УДАЛИТЬ: ОХЛАЖДЕНИЕ	PROIBIZIONE RAFFREDD.	FROID INACTIF	VAL KYLDRIFT
Temperature range limit setting		LIMIT TEMP FUNCTION	LIMIT TEMP FUNKTION	LIMIT TEMP CONSIGNA	ОГРАНИЧЕНИЕ УСТ.ТЕМПЕРАТ	LIMITAZIONE TEMPERATURA	LIMITATION TEMPERATURE	MIN MAX TEMP VAL
Temperature range limit setting mode	Hot water	LIMIT TEMP HOT WATER	LIMIT TEMP BRAUCH-H2O	TEMP LIMITE AGUA CALIEN.	ОГРАНИЧ. °° ГОРЯЧ. ВОДА	LIMITE TEMP. ACQUA SAN.	LIMITE TEMP EAU CHAUDE	MAXTEMP VÄRMVATTEN
	Anti-freeze	LIMIT TEMP ANTI-FREEZE	LIMIT TEMP FROST-SCHUTZ	TEMP LIMITE ANTI-CONGEL.	ОГРАНИЧ. °° АНТИ-ФРИЗ	LIMITE TEMP. ANTIGELO	LIMITE TEMP ANTI GIVRE	MINTEMP FRYS SKYDD
	Cooling	LIMIT TEMP COOLING	LIMIT TEMP KÜHLEN	TEMP LIMITE MODO FRIO	ОГРАНИЧ. °° ОХЛАЖДЕНИЕ	LIMITE TEMP. RAFFREDD.	LIMITE TEMP EN FROID	MINTEMP KYLDRIFT
Mode selection		MODE SELECTION	Betriebsart wählen	SELECCIÓN DE MODO	ВЫБОР РЕЖИМА	SELEZIONE MODO	SELECTION DU MODE	LÅGE VAL
Remote controller setting MAIN		CONTROLLER MAIN	Haupt controller	CONTROL PRINCIPAL	ОСНОВНОЙ ПУЛЬТ	CONTROLLO MAIN	TEKOMMANDE MAÎTRE	MASTER STYR
Remote controller setting SUB		CONTROLLER SUB	Neben controller	CONTROL SECUNDARIO	ДОПОЛНИТЕЛЬНЫЙ ПУЛЬТ	CONTROLLO SUB	TEKOMMANDE ESCLAVE	SLAV STYR
Use of clock setting		CLOCK	Uhr	RELOJ	Часы	OROLOGIO	AFFICHAGE HORLOGE	KLOCKA
Setting the day of the week and time		TIME SET ±:ENTER	Uhr stellen ±:einstellen	CONFIG RELOJ ±:CONFIG	Часы: УСТ. ±:ВВОД	OROLOGIO ±:ENTER	HORLOGE ±:ENTER	TIME SET ±:ENTER
Contact number setting		CALL 012 3456 7890	CALL 012 3456 7890	CALL 012 3456 7890	CALL 012 3456 7890	CALL 012 3456 7890	CALL 012 3456 7890	RING: 344-455665
Temperature off set function		TEMP OFFSET FUNCTION	SET ΔT FUNKTION	AJUSTE TEMP DIFERENCIAL	ПОГРЕШНОСТЬ ИЗМЕРЕНИЯ	IMPOSTA OFFSET	REGLAGE DELTA EAU	TEMP DIFFERENS
Temperature off set function (Heating)		TEMP OFFSET HEATING	SET ΔT HEIZEN	DIFERENCIAL MODO CALOR	ПОГРЕШНОСТЬ НАГРЕВ	OFFSET ACQUA RISCALD.	EN MODE CHAUD	TEMP DIFFERENS VÄRME
Temperature off set function (Cooling)		TEMP OFFSET COOLING	SET ΔT KÜHLEN	DIFERENCIAL MODO FRIO	ПОГРЕШНОСТЬ ОХЛАЖДЕНИЯ	OFFSET ACQUA RAFFREDD.	EN MODE FROID	TEMP DIFFERENS KYLA
Timer set		TIMER SET ±:ENTER	Zeitschaltuhr ±:einstellen	TEMPORIZA - DOR ±:CONFIG	ТАЙМЕР: УСТ. ±:ВВОД	TIMER ±:ENTER	PROG HORAIRE ±:ENTER	TIMER SET ±:ENTER
Timer monitor		TIMER MONITOR	Uhrzeit Anzeige	VISUALIZAR TEMPORIZAD.	ПРОСМОТР ТАЙМЕРА	VISUALIZ TIMER	AFFICHAGE PROG HORAIRE	TIMER MONITOR
Timer mode off		TIMER MODE OFF	Zeitschaltuhr AUS	TEMPORIZA - DOR APAGADO	ТАЙМЕР: ВЫКЛ.	TIMER OFF	PROG HORAIRE INACTIF	TIMER LÅGE AV
Timer function setting		WEEKLY TIMER	Wochenzeit schalt Uhr	TEMPORIZA - DOR SEMANAL	НЕДЕЛЬНЫЙ ТАЙМЕР	TIMER SETTIMANALE	SELECTION PROG HORAIRE	VECKO TIMER
Simple timer		SIMPLE TIMER	Einfache Zeitfunktion	TEMPORIZA - DOR SIMPLE	ПРОСТОЙ ТАЙМЕР	TIMER SEMPLIFICATO	PROG HORAIRE SIMPLIFIE	ENKEL TIMER

[Dot display table]

Selecting language	English	German	Spanish	Russian	Italian	French	Swedish	
Auto off timer	AUTO OFF TIMER	Auto Zeit funktion AUS	APAGADO AUTOMÁTICO	АВТООТКЛЮЧ. ПО ТАЙМЕРУ	AUTO OFF TIMER	PROG HORAIRE ARRET AUTO	AUTO TIMER AV	
Function selection	FUNCTION SELECTION	Funktion auswählen	SELECCIÓN DE FUNCIONES	ВЫБОР ФУНКЦИИ	SELEZIONE FUNZIONI	SELECTION FONCTIONS	LÄGE VAL	
Check (Error)	CHECK	Prüfen	COMPROBAR	ПРОВЕРКА	CHECK	CONTROLE	CHECK	
Test run	TEST RUN	Testbetrieb	TEST FUNCIONAMIENTO	ТЕСТОВАЯ ЗАПУСК	TEST RUN	TEST	TEST LÄGE	
Self check	SELF CHECK	Selbst-diagnose	AUTO REVISIÓN	САМОДИАГНОСТИКА	SELF CHECK	AUTO CONTROLE	SJÄLV CHECK	
Collective setting	COLLECTIVELY SETTING	COLLECTIVELY SETTING	COLLECTIVELY SETTING	COLLECTIVELY SETTING	COLLECTIVELY SETTING	COLLECTIVELY SETTING	KOLEKTIV VAL	
Water temperature (Initial setting)	Heating	WATER TEMP HEATING	SOLLWERT HEIZEN	TEMP. AGUA MODO CALOR	± ВОАБІ: НАГРІВ	TEMP.ACQUA RISCALD.	TEMP EAU CHAUFFAGE	BÖRVARDE UARMEDRIFT
	Heating ECO	WATER TEMP HEATING ECO	SOLLWERT HEIZEN-ECO	TEMP. AGUA CALOR ECO	± ВОАБІ: НАГРІВ ЭКО	TEMP.ACQUA RISCALD.ECO	TEMP EAU CHAUDE ECO	BÖRVARDE UARME ECO
	Hot water	WATER TEMP HOT WATER	SOLLWERT BRAUCH-H2O	TEMP. AGUA AGUA CALIEN.	± ВОАБІ: ГОРЯЧ. ВОДА	TEMP.ACQUA SANITARIA	REGLAGETEMP EAU CHAUDE	BÖRVARDE UARMVATTEN
	Anti-freeze	WATER TEMP ANTI-FREEZE	SOLLWERT FROSTSCHUTZ	TEMP. AGUA ANTICONGEL.	± ВОАБІ: АНТИФРИЗ	TEMP.ACQUA ANTIGELO	TEMP ANTI GIVRE	BÖRVARDE FRYSSKYDD
	Cooling	WATER TEMP COOLING	SOLLWERT KALT-HEO	TEMP. AGUA MODO FRIO	± ВОАБІ: ОХЛАЖАЕННІ	TEMP.ACQUA RAFFREDD.	TEMP EAU EN FROID	BÖRVARDE KYLDRIFT
Option setting(Heating)	AD INPUT HEATING	AD-EINGANG HEIZEN	ENTRADA AD MODO CALOR	ДИАПАЗОН ± НАГРІВ	INPUT TEMP. RISCALD.	SIGNAL ENTREE EN CHAUD	KONFIGURE UARMEDRIFT	
Option setting(Cooling)	AD INPUT COOLING	AD-EINGANG KÜHLEN	ENTRADA AD MODO FRIO	ДИАПАЗОН ± ОХЛАЖАЕННІ	INPUT TEMP. RAFFREDD.	SIGNAL ENTREE EN FROID	KONFIGURE KYLDRIFT	
Water circuit check	Check WATER CIRCUIT	PRÜFE H2O-KREIS	COMPROBAR CIRCUIT. AGUA	ПРОВЕРЬТЕ КОНТУР ВОДІ	VERIFICARE CIRC.ACQUA	CONTROLE FILTRE AEAU	VATTENFILTER CHECK	
Waiting for response	LOADING...	LADEN...	CARGANDO	ЗАГРУЗКА НАСТРОЕК...	LOADING...	CHARGEMENT	BEKRÄFTAR	
Waiting for setting	SETTING	EINSTELLUNG	AJUSTES	ОТПРАВКА НАСТРОЕК	SETTING...	REGLAGE	KONFIGURE	
Not dealt with	NOT AVAIL	NOT AVAIL	NOT AVAIL	NOT AVAIL	NOT AVAIL	NOT AVAIL	NOT AVAIL	
Maintenance	MAINTENANCE	MAINTENANCE	MAINTENANCE	MAINTENANCE	MAINTENANCE	MAINTENANCE	MAINTENANCE	

5. Initial setting by remote controller

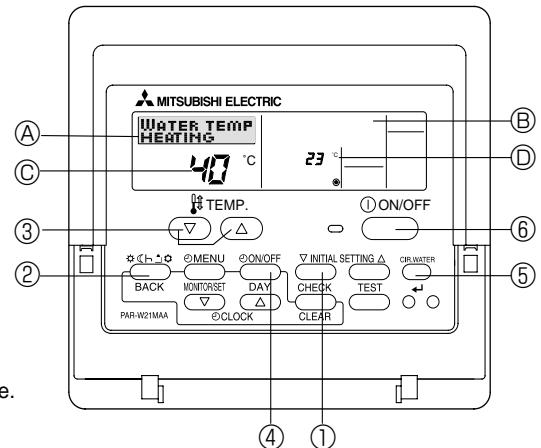

(1) Press the **INITIAL SETTING** button ① for 3 seconds to activate the initial setting mode.

(2) [DISPLAY ①]

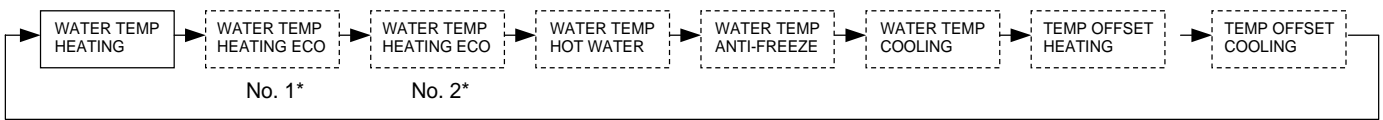

* No.1 or No.2 is indicated in display ①.

Press **MODE** button ② to switch to the next parameter setting.

<Target temperature in heating mode>

WATER TEMP
HEATING

Set target flow water temperature in Heating mode with [TEMP] buttons (▼ and ▲) ③.

<Parameters for Heating ECO mode>

Set following 4 parameters in HEATING ECO mode with [TEMP] buttons (▼ and ▲) ③.
HEATING ECO mode= Weather compensation mode
Target flow water temperature varies according to the outdoor temperature.

WATER TEMP
HEATING ECO

No.1 Display ③ shows target flow temperature.
Display ④ shows outdoor temperature.

WATER TEMP
HEATING ECO

No. 2 Display ③ shows target flow temperature.
Display ④ shows outdoor temperature.

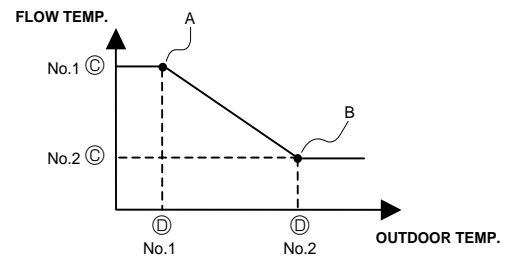

Press **ON/OFF** button ④ to switch ③ ↔ ④ alternately. (The blinking figure can be changed.)

Note:

- Heating ECO mode sets the set temperature depending on the outdoor temperature.
- The parameters except the above 4 parameters cannot be set. (The characteristic is linear between the point A and B.)
- When the "EXTERNAL INPUT(analog signal)" is used, the "HEATING ECO MODE" is invalid.

<Target temperature in HOT WATER mode>

WATER TEMP
HOT WATER

Set target flow water temperature in HOT WATER mode with [TEMP] buttons (▼ and ▲) ③.

<Target temperature in ANTI-FREEZE mode>

WATER TEMP
ANTI-FREEZE

Set target flow water temperature in ANTI-FREEZE mode with [TEMP] buttons (▼ and ▲) ③.

<Target temperature in COOLING mode>

WATER TEMP
COOLING

Set target flow water temperature in COOLING mode with [TEMP] buttons (▼ and ▲) ③.

<Temperature OFFSET setting>

This setting is to adjust the difference between the actual flow water temperature at the refrigerant-water heat exchanger outlet and the temperature sensed by TH1 which tends to be lower due to heat leakage from water piping.

HEATING mode

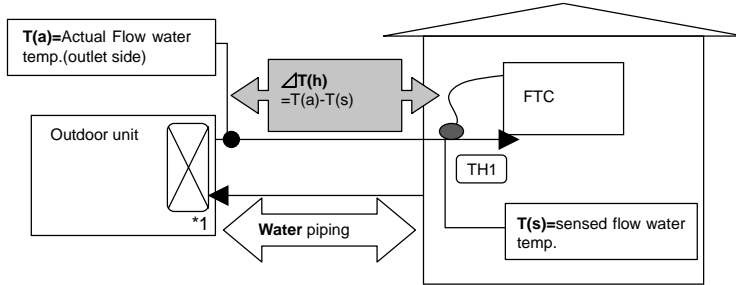

COOLING mode

*1 Refrigerant-water HEX

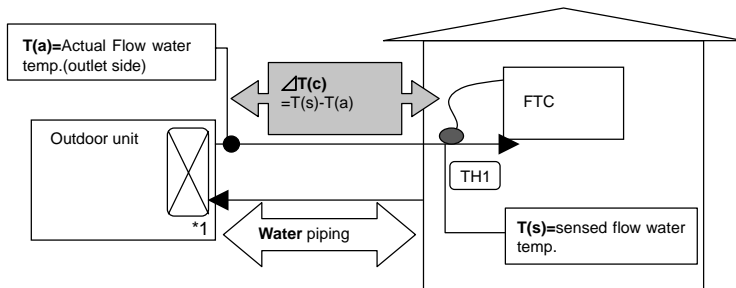

TEMP OFFSET HEATING

Set OFFSET temperature $\Delta T(h)$ in HEATING mode with [TEMP] buttons (∇ and \blacktriangle) ③.

TEMP OFFSET COOLING

Set OFFSET temperature $\Delta T(c)$ in COOLING mode with [TEMP] buttons (∇ and \blacktriangle) ③.

◆ In order to let the PCB memorize the changed parameters

Make sure to press the **CIR.WATER** button ⑤ before quitting the INITIAL SETTING mode.

If you press the **ON/OFF** button ⑥ in INITIAL SETTING mode before pressing the **CIR.WATER** button ⑤, you can exit from this mode without any change.

6. Definition of analog signal by remote controller (Required only for ANALOG TEMP. system)

Set following 2 parameters to assign the target temperature value to analog signal figures.

(1) Press **[INITIAL SETTING]** button ① for 3 seconds to activate this setting mode.

(2) [DISPLAY ④]

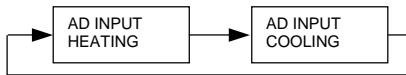

Press **[MODE]** button ② to switch to the next parameter setting.

AD INPUT HEATING

Set flow temp. for No.1 and No.2 with [TEMP] buttons (▼ and ▲) ③.

AD INPUT COOLING

Set flow temp. for No.1 and No.2 with [TEMP] buttons (▼ and ▲) ③.

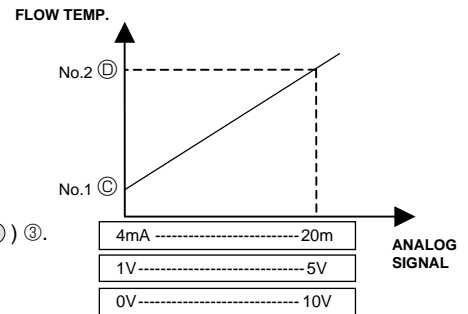

Press **[ON/OFF]** button ④ to switch ③ ↔ ④ alternately. (The blinking figure can be changed.)



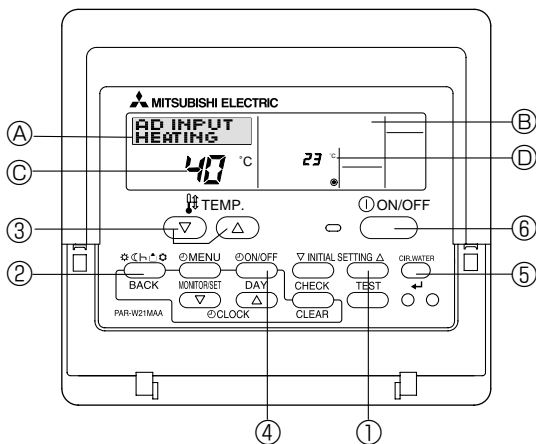

◆ In order to let FTC memorize set parameters

Make sure to press **[CIR.WATER]** button ⑤ before exit from ANALOG SIGNAL ADJUST mode.

If you press **[ON/OFF]** button ⑥ before pressing **[CIR.WATER]** button ⑤ in ADJUST mode, you can exit from this mode without making any change.



7. Troubleshooting

A flowing water sound or occasional hissing sound is heard.	<ul style="list-style-type: none"> These sounds can be heard when refrigerant is flowing in the indoor unit, refrigerant pipe or when the refrigerant is chaging.
Water does not heat or cool well.	<ul style="list-style-type: none"> Clean the filter of water piping. (Flow is reduced when the filter is dirty or clogged.) Check the temperature adjustment and adjust the set temperature. Make sure that there is plenty of space around the outdoor unit.
Water or vapor is emitted from the outdoor unit.	<ul style="list-style-type: none"> During cooling mode, water may form and drip from the cool pipes and joints. During heating mode, water may form and drip from the heat exchanger of outdoor unit. During defrosting mode, water on the heat exchanger of outdoor unit evaporates and water vapor may be emitted.
The operation indicator does not appear in the remote controller display.	<ul style="list-style-type: none"> Turn on the power switch. "●" will appear in the remote controller display.
"  appears in the remote controller display.	<ul style="list-style-type: none"> During external signal control, "" appears in the remote controller display and FTC operation cannot be started or stopped using the remote controller.
When restarting the outdoor unit soon after stopping it, it does not operate even though the ON/OFF button is pressed.	<ul style="list-style-type: none"> Wait approximately 3 minutes. (Operation has stopped to protect the outdoor unit.)
FTC operates without the ON/OFF button being pressed.	<ul style="list-style-type: none"> Is the on timer set? Press the ON/OFF button to stop operation. Is the FTC connected to a external signal? Consult the concerned people who control the FTC. Does " appear in the remote controller display? Consult the concerned people who control the FTC. Has the auto recovery feature from power failures been set? Press the ON/OFF button to stop operation.
FTC stops without the ON/OFF button being pressed.	<ul style="list-style-type: none"> Is the off timer set? Press the ON/OFF button to restart operation. Is the air conditioner connected to a central remote controller? Consult the concerned people who control the FTC. Does " appear in the remote controller display? Consult the concerned people who control the FTC.
Remote controller timer operation cannot be set.	<ul style="list-style-type: none"> Are timer settings invalid? If the timer can be set, (WEEKLY) , (SIMPLE) , or (AUTO OFF) appears in the remote controller display.
"PLEASE WAIT" appears in the remote controller display.	<ul style="list-style-type: none"> The initial settings are being performed. Wait approximately 3 minutes. If the remote controller is not only for FTC, change it.
An error code appears in the remote controller display.	<ul style="list-style-type: none"> The protection devices have operated to protect the FTC and outdoor unit. Do not attempt to repair this equipment by yourself. Turn off the power switch immediately and consult your dealer. Be sure to provide the dealer with the model name and information that appeared in the remote controller display.

- If the unit cannot be operated properly after test run, refer to the following table to find the cause.

Symptom		Cause
Wired remote controller	LED 1, 2 (PCB in outdoor unit)	
PLEASE WAIT	For about 2 minutes after power-on After LED 1, 2 are lighted, LED 2 is turned off, then only LED 1 is lighted. (Correct operation)	<ul style="list-style-type: none"> For about 2 minutes following power-on, operation of the remote controller is not possible due to system start-up. (Correct operation)
PLEASE WAIT → Error code	Subsequent to about 2 minutes after power-on	<ul style="list-style-type: none"> Connector for the outdoor unit's protection device is not connected. Reverse or open phase wiring for the outdoor unit's power terminal block (L1, L2, L3)
Display messages do not appear even when operation switch is turned ON (operation lamp does not light up).		<ul style="list-style-type: none"> Incorrect wiring between FTC and outdoor (incorrect polarity of S1, S2, S3) Remote controller wire short

Note: Operation is not possible for about 30 seconds after cancellation of function selection. (Correct operation)

For description of each LED (LED1, 2, 3) provided on the FTC, refer to the following table.

LED1 (power for microcomputer)	Indicates whether control power is supplied. Make sure that this LED is always lit.
LED2 (power for remote controller)	Indicates whether power is supplied to the remote controller. This LED lights only in the case of the FTC which is connected to the outdoor unit refrigerant addresses "0".
LED3 (communication between FTC and outdoor units)	Indicates state of communication between the FTC and outdoor units. Make sure that this LED is always blinking.

Error code indication

You can check an error code on both ① and ②.

① LCD display on remote controller

② 2-digit LED indicator on outdoor unit PCB

(For SPLIT type outdoor unit, this LED indicator is optional parts.PAC-SK52ST)

* The 2-digit LED indicator on outdoor unit PCB can display indoor side error as well.

[1] SELF-DIAGNOSIS ACTION TABLE

Error Code	Abnormal point and detection method	Cause	Countermeasure										
P1	<p>Actual flow water temperature thermistor (TH1)</p> <p>① The unit is in 3-minute resume prevention mode if short/open of thermistor is detected. Abnormal if the unit does not reset normally after 3 minutes. (The unit returns to normal operation, if it has been reset normally.)</p> <p>② Constantly detected during cooling, drying, and heating operation. Short: -90°C or more Open: -40°C or less</p>	<p>① Defective thermistor characteristics</p> <p>② Contact failure of TB61 No.1-2 on PCB of FTC</p> <p>③ Breaking of wire or contact failure of thermistor wiring</p> <p>④ Defective PCB of FTC</p>	<p>①-③ Check resistance value of thermistor.</p> <table border="1"> <tr> <td>0°C</td> <td>15.0kΩ</td> </tr> <tr> <td>10°C</td> <td>9.6kΩ</td> </tr> <tr> <td>20°C</td> <td>6.3kΩ</td> </tr> <tr> <td>30°C</td> <td>4.3kΩ</td> </tr> <tr> <td>40°C</td> <td>3.0kΩ</td> </tr> </table> <p>If you put force on (draw or bend) the lead wire with measuring resistance value of thermistor, breaking of wire or contact failure can be detected.</p> <p>② Check contact failure of TB61 No.1-2 on PCB of FTC. Refer to 8. Turn the power on again and check restart after inserting connector again.</p> <p>④ Check actual flow water temperature display on remote controller. Replace PCB of FTC if there is abnormal difference with actual flow water temperature.</p> <p>Turn the power off, and on again to operate after check.</p>	0°C	15.0kΩ	10°C	9.6kΩ	20°C	6.3kΩ	30°C	4.3kΩ	40°C	3.0kΩ
0°C	15.0kΩ												
10°C	9.6kΩ												
20°C	6.3kΩ												
30°C	4.3kΩ												
40°C	3.0kΩ												
P2	<p>Pipe temperature thermistor/Liquid (TH2)</p> <p>① The unit is in 3-minute resume prevention mode if short/open of thermistor is detected. Abnormal if the unit does not reset normally after 3 minutes. (The unit returns to normal operation, if it has been reset normally.)</p> <p>② Constantly detected during cooling, drying, and heating (except defrosting) operation Short: 90°C or more Open: -40°C or less</p>	<p>① Defective thermistor characteristics</p> <p>② Contact failure of TB61 No.3-4 on PCB of FTC</p> <p>③ Breaking of wire or contact failure of thermistor wiring</p> <p>④ Defective refrigerant circuit is causing thermistor temperature of 90°C or more or -40°C or less.</p> <p>⑤ Defective PCB of FTC</p>	<p>①-③ Check resistance value of thermistor. For characteristics, refer to (P1) above.</p> <p>② Check contact failure of TB61 No.3-4 on PCB of FTC. Refer to 8. Turn the power on and check restart after inserting connector again.</p> <p>④ Check pipe <liquid> temperature with remote controller in test run mode. If pipe <liquid> temperature is extremely low (in cooling mode) or high (in heating mode), refrigerant circuit may have defective.</p> <p>⑤ Check pipe <liquid> temperature with remote controller in test run mode. If there is extremely difference with actual pipe <liquid> temperature, replace PCB of FTC.</p> <p>Turn the power off, and on again to operate after check.</p>										
P6	<p>Freezing/overheating protection is working</p> <p>① Freezing protection (Cooling mode) The unit is in 6-minute resume prevention mode if pipe temperature stays under -15°C for 3 minutes, 3 minutes after the compressor started. Abnormal if it stays under -15°C for 3 minutes again within 16 minutes after 6-minute resume prevention mode.</p> <p>② Overheating protection (Heating mode) The units is in 6 minute resume prevention mode if pipe temperature is detected as over 70°C after the compressor started. Abnormal if the temperature of over 70°C is detected again within 30 minutes after 6 minute resume prevention mode.</p>	<p>(Cooling mode)</p> <p>① Short cycle of air path</p> <p>② Low-load (low temperature) operation out of the tolerance range</p> <p>③ Defective outdoor fan control</p> <p>④ Overcharge of refrigerant</p> <p>⑤ Defective refrigerant circuit (clogs)</p> <p>(Heating mode)</p> <p>① Short cycle of air path</p> <p>② Over-load (high temperature) operation out of the tolerance range</p> <p>③ Defective outdoor fan control</p> <p>④ Overcharge of refrigerant</p> <p>⑤ Defective refrigerant circuit (clogs)</p> <p>⑥ Bypass circuit of outdoor unit is defective.</p>	<p>(Cooling mode)</p> <p>① Remove shields.</p> <p>③ Check outdoor fan motor.</p> <p>④⑤ Check operating condition of refrigerant circuit.</p> <p>(Heating mode)</p> <p>① Remove shields.</p> <p>③ Check outdoor fan motor.</p> <p>④-⑥ Check operating condition of refrigerant circuit.</p>										



Error Code	Abnormal point and detection method	Cause	Countermeasure
E0 or E4	<p>Remote controller transmission error (E0)/signal receiving error (E4)</p> <p>① Abnormal if main or sub remote controller cannot receive any transmission normally from FTC of refrigerant address "0" for 3 minutes. (Error code: E0)</p> <p>② Abnormal if sub-remote controller could not receive any signal for 2 minutes. (Error code: E0)</p> <p>① Abnormal if FTC can not receive any data normally from remote controller board or from other Interface/Flow temp. controller board for 3 minutes. (Error code: E4)</p> <p>② FTC cannot receive any signal from remote controller for 2 minutes. (Error code: E4)</p>	<p>① Contact failure at transmission wire of remote controller</p> <p>② All remote controllers are set as "sub" remote controller. In this case, E0 is displayed on remote controller, and E4 is displayed at LED (LED1, LED2) on the outdoor controller circuit board.</p> <p>③ Miswiring of remote controller</p> <p>④ Defective transmitting receiving circuit of remote controller</p> <p>⑤ Noise has entered into the transmission wire of remote controller.</p>	<p>① Check disconnection or looseness of FTC or transmission wire of remote controller.</p> <p>② Set one of the remote controllers "main", If there is no problem with the action above.</p> <p>③ Check wiring of remote controller.</p> <ul style="list-style-type: none"> • Total wiring length: max. 500 m (Do not use cablex 3 or more.) • The number of connecting remote controller: max. 2 units <p>When it is not the above-mentioned problem of ①~③</p> <p>④ Diagnose remote controllers.</p> <p>a) When "RC OK" is displayed, remote controllers have no problem. Turn the power off, and on again to check. If abnormality generates again, replace PCB of FTC.</p> <p>b) When "RC NG" is displayed, replace remote controller.</p> <p>c) When "RC E3" or "ERC 00-66" is displayed, noise may be causing abnormality.</p>
E1 or E2	<p>Remote controller control board</p> <p>① Abnormal if data cannot be read normally from the nonvolatile memory of the remote controller control board. (Error code: E1)</p> <p>② Abnormal if the clock function of remote controller cannot be operated normally. (Error code: E2)</p>	<p>① Defective remote controller</p>	<p>① Replace remote controller.</p>
E3 or E5	<p>Remote controller transmission error (E3)/signal receiving error (E5)</p> <p>① Abnormal if remote controller could not find blank of transmission path for 6 seconds and could not transmit. (Error code: E3)</p> <p>② When remote controller receives the transmitted data same time and compares these data. Abnormal if the data is judged to be different for 30 continuous times. (Error code: E3)</p> <p>① Abnormal if FTC could not find blank of transmission path. (Error code: E5)</p> <p>② When FTC receives the transmitted data same time and compares these data. Abnormal if the data is judged to be different for 30 continuous times. (Error code: E5)</p>	<p>① 2 remote controllers are set as "main." (In case of 2 remote controllers)</p> <p>② Defective transmitting receiving circuit of remote controller</p> <p>③ Defective transmitting receiving circuit of FTC</p> <p>④ Noise has entered into transmission wire of remote controller.</p>	<p>① Set a remote controller to main, and the other to sub.</p> <p>②~④ Diagnose remote controller.</p> <p>a) When "RC OK" is displayed, remote controllers have no problem. Turn the power off, and on again to check. When becoming abnormal again, replace indoor controller board.</p> <p>b) When "RC NG" is displayed, replace remote controller.</p> <p>c) When "RC E3" or "ERC 00-66" is displayed, noise may be causing abnormality.</p>
E6	<p>FTC/outdoor unit communication error (Signal receiving error)</p> <p>① Abnormal if FTC cannot receive any signal normally for 6 minutes after turning the power on.</p> <p>② Abnormal if FTC cannot receive any signal normally for 3 minutes.</p>	<p>① Contact failure, short circuit or, miswiring (converse wiring) of FTC/outdoor unit connecting wire</p> <p>② Defective transmitting receiving circuit of FTC</p> <p>③ Defective transmitting receiving circuit of FTC</p> <p>④ Noise has entered into FTC/outdoor unit connecting wire.</p>	<p>* Check LED display on the outdoor control circuit board. (Connect A-control service tool, PAC-SK52ST.)</p> <p>① Check disconnection or looseness of FTC/outdoor unit connecting wire of FTC or outdoor unit.</p> <p>②~④ Turn the power off, and on again to check. If abnormality generates again, replace FTC or outdoor controller circuit board.</p>



Error Code	Abnormal point and detection method	Case	Judgment and action
E8	FTC/outdoor unit communication error (Signal receiving error) (Outdoor unit) (1) Abnormal if outdoor controller circuit board could not receive anything normally for 3 minutes.	① Contact failure of FTC/outdoor unit connecting wire ② Defective communication circuit of outdoor controller circuit board ③ Defective communication circuit of FTC ④ Noise has entered into FTC/outdoor unit connecting wire.	① Check disconnection or looseness of FTC/outdoor unit connecting wire of FTC or outdoor unit. ②~④ Turn the power off, and on again to check. Replace PCB of FTC or outdoor controller circuit board if abnormality is displayed again.
E9	FTC/outdoor unit communication error (Transmitting error) (Outdoor unit) (1) Abnormal if "0" receiving is detected 30 times continuously though outdoor controller circuit board has transmitted "1". (2) Abnormal if outdoor controller circuit board could not find blank of transmission path for 3 minutes.	① FTC/outdoor unit connecting wire has contact failure. ② Defective communication circuit of outdoor controller circuit board ③ Noise has entered power supply. ④ Noise has entered FTC/outdoor unit connecting wire.	① Check disconnection or looseness of FTC/outdoor unit connecting wire. ②~④ Turn the power off, and on again to check. Replace outdoor controller circuit board if abnormality is displayed again.
EF	Non defined error code This code is displayed when non defined error code is received.	① Noise has entered transmission wire of remote controller. ② Noise has entered Interface unit/Flow temp. controller-outdoor unit connecting wire.	①② Turn the power off, and on again to check. Replace Interface/Flow temp. controller board or outdoor controller circuit board if abnormality is displayed again.
Ed	Serial communication error Abnormal if serial communication between outdoor controller circuit board and outdoor power circuit board is defective.	① Wire disconnection or contact failure of connector CN2 between the outdoor controller circuit board and the outdoor power circuit board ② Wire disconnection or contact failure of connector CN4 between the outdoor controller circuit board and the outdoor power circuit board ③ Defective communication circuit of outdoor power circuit board ④ Defective communication circuit of outdoor controller circuit board for outdoor power circuit board	①② Check connection of each connector CN2 and CN4 between the outdoor controller circuit board and the outdoor power circuit board. ③ Replace outdoor power circuit board. ④ Replace outdoor controller circuit board.

[2] HOW TO "MONITOR THE OPERATION DATA"

- Turn on the [Monitoring the operation data]

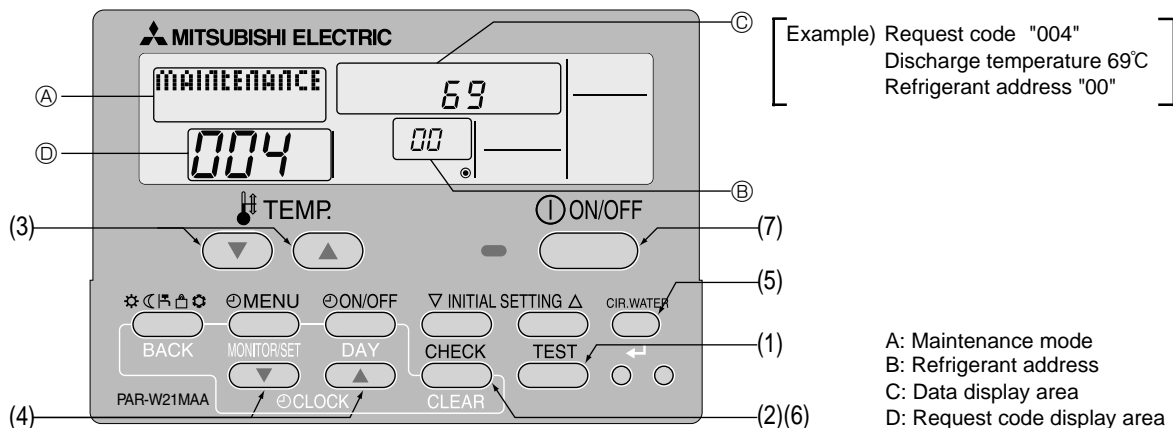

- (1) Press the **TEST** button for 3 seconds so that [Maintenance mode] appears on the screen (at A).
- (2) Press the **CHECK** button for 3 seconds to switch to [Maintenance monitor].
 Note) It is not possible to switch to [Maintenance monitor] during data request in maintenance mode (i.e., while " --- " is blinking) since no buttons are operative.

- Operating the service inspection monitor
 [- - -] appears on the screen (at B) when [Maintenance monitor] is activated.
 (The display (at B) now allows you to set a request code No.)
- (3) Press the [TEMP] buttons (**▽** and **△**) to select the desired refrigerant address.



- (4) Press the [CLOCK] buttons (**▽** and **△**) to set the desired request code No.
- (5) Press the **CIR.WATER** button to perform data request.
 (The requested data will be displayed at C in the same way as in maintenance mode.)

Data collected during operation of the remote controller will be displayed.
 The collected data such as temperature data will not be updated automatically even if the data changes.
 To display the updated data, carry out step (4) again.

- Canceling the Monitoring the operation data
- (6) While [Maintenance monitor] is displayed, press the **CHECK** button for 3 seconds to return to maintenance mode.
 - (7) To return to normal mode, press the **ON/OFF** button.

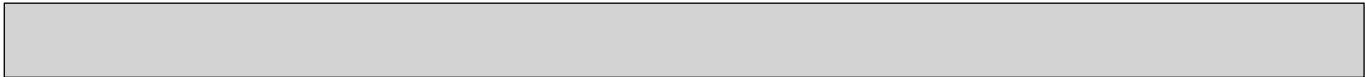

[3] Request code list

* Certain FTC/outdoor combinations do not have the request code function; therefore, no request codes are displayed.

Request code	Request content	Description (Display range)	Unit	Remarks
0	Operation state	Refer to Detail Contents in Request Code.	–	
1	Compressor-Operating current (rms)	0 – 50	A	
2	Compressor-Accumulated operating time	0 – 9999	10 hours	
3	Compressor-Number of operation times	0 – 9999	100 times	
4	Discharge temperature (TH4)	3 – 217	°C	
5	Outdoor unit - Liquid pipe 1 temperature (TH3)	-40 – 90	°C	
6	Outdoor unit - Liquid pipe 2 temperature	-40 – 90	°C	
7	Outdoor unit-2-phase pipe temperature (TH6)	-39 – 88	°C	
8	Outdoor unit-Suction pipe temperature (TH32)	-39 – 88	°C	
9	Outdoor unit-Outside air temperature (TH7)	-39 – 88	°C	
10	Outdoor unit-Heatsink temperature (TH8)	-40 – 200	°C	
11				
12	Discharge superheat (SHd)	0 – 255	°C	
13	Sub-cool (SC)	0 – 130	°C	
14				
15				
16	Compressor-Operating frequency	0 – 255	Hz	
17	Compressor-Target operating frequency	0 – 255	Hz	
18	Outdoor unit-Fan output step	0 – 10	Step	
19	Outdoor unit-Fan 1 speed (Only for air conditioners with DC fan motor)	0 – 9999	rpm	
20	Outdoor unit-Fan 2 speed (Only for air conditioners with DC fan motor)	0 – 9999	rpm	"0" is displayed if the air conditioner is a single-fan type.
21				
22	LEV (A) opening	0 – 500	Pulses	
23	LEV (B) opening	0 – 500	Pulses	
24	LEV (C) opening	0 – 500	Pulses	
25	Primary current	0 – 50	A	
26	DC bus voltage	180 – 370	V	
27				
28				
29	Number of connected FTC units	0 – 4	Units	
30				
31				
32				
33				
34				
35				
36				
37				
38				
39				
40				
41				
42				
43				
44				
45				
46				
47				
48	Thermostat ON operating time	0 – 999	Minutes	
49	Test run elapsed time	0 – 120	Minutes	← Not possible to activate maintenance mode during the test run.



Request code	Request content	Description (Display range)	Unit	Remarks
50	FTC unit-Control state	Refer to Detail Contents in Request Code.	-	
51	Outdoor unit-Control state	Refer to Detail Contents in Request Code.	-	
52	Compressor-Frequency control state	Refer to Detail Contents in Request Code.	-	
53	Outdoor unit-Fan control state	Refer to Detail Contents in Request Code.	-	
54	Actuator output state	Refer to Detail Contents in Request Code.	-	
55	Error content (U9)	Refer to Detail Contents in Request Code.	-	
56				
57				
58				
59				
60	Signal transmission demand capacity	0 – 255	%	
61	Contact demand capacity	Refer to Detail Contents in Request Code.	-	
62	External input state (silent mode, etc.)	Refer to Detail Contents in Request Code.	-	
63				
64				
65				
66				
67				
68				
69				
70	Outdoor unit-Capacity setting display	Refer to Detail Contents in Request Code.	-	
71	Outdoor unit-Setting information	Refer to Detail Contents in Request Code.	-	
72				
73	Outdoor unit-SW1 setting information	Refer to Detail Contents in Request Code.	-	
74	Outdoor unit-SW2 setting information	Refer to Detail Contents in Request Code.	-	
75				
76	Outdoor unit-SW4 setting information	Refer to Detail Contents in Request Code.	-	
77	Outdoor unit-SW5 setting information	Refer to Detail Contents in Request Code.	-	
78	Outdoor unit-SW6 setting information	Refer to Detail Contents in Request Code.	-	
79	Outdoor unit-SW7 setting information	Refer to Detail Contents in Request Code.	-	
80	Outdoor unit-SW8 setting information	Refer to Detail Contents in Request Code.	-	
81	Outdoor unit-SW9 setting information	Refer to Detail Contents in Request Code.	-	
82	Outdoor unit-SW10 setting information	Refer to Detail Contents in Request Code.	-	
83				
84	M-NET adapter connection (presence/absence)	"0000": Not connected "0001": Connected	-	
85				
86				
87				
88				
89	Display of execution of replace/wash operation	"0000": Not washed "0001": Washed	-	
90	Outdoor unit-Microcomputer version information	Examples) Ver 5.01 → "0501"	Ver	
91	Outdoor unit-Microcomputer version information (sub No.)	Auxiliary information (displayed after version information) Examples) Ver 5.01 A000 → "A000"	-	
92				
93				
94				
95				
96				
97				
98				
99				
100	Outdoor unit - Error postponement history 1 (latest)	Displays postponement code. (" - " is displayed if no postponement code is present)	Code	
101	Outdoor unit - Error postponement history 2 (previous)	Displays postponement code. (" - " is displayed if no postponement code is present)	Code	
102	Outdoor unit - Error postponement history 3 (last but one)	Displays postponement code. (" - " is displayed if no postponement code is present)	Code	



Request code	Request content	Description (Display range)	Unit	Remarks
103	Error history 1 (latest)	Displays error history. ("-" is displayed if no history is present.)	Code	
104	Error history 2 (second to last)	Displays error history. ("-" is displayed if no history is present.)	Code	
105	Error history 3 (third to last)	Displays error history. ("-" is displayed if no history is present.)	Code	
106	Abnormal thermistor display (TH3/TH6/TH7/TH8)	3 : TH3 6 : TH6 7 : TH7 8 : TH8 0 : No thermistor error	Sensor number	
107	Operation mode at time of error	Displayed in the same way as request code "0".	-	
108	Compressor-Operating current at time of error	0 - 50	A	
109	Compressor-Accumulated operating time at time of error	0 - 9999	10 hours	
110	Compressor-Number of operation times at time of error	0 - 9999	100 times	
111	Discharge temperature at time of error	3 - 217	°C	
112	Outdoor unit - Liquid pipe 1 temperature (TH3) at time of error	-40 - 90	°C	
113	Outdoor unit - Liquid pipe 2 temperature at time of error	-40 - 90	°C	
114	Outdoor unit-2-phase pipe temperature (TH6) at time of error	-39 - 88	°C	
115				
116	Outdoor unit-Outside air temperature (TH7) at time of error	-39 - 88	°C	
117	Outdoor unit-Heatsink temperature (TH8) at time of error	-40 - 200	°C	
118	Discharge superheat (SHd) at time of error	0 - 255	°C	
119	Sub-cool (SC) at time of error	0 - 130	°C	
120	Compressor-Operating frequency at time of error	0 - 255	Hz	
121	Outdoor unit at time of error • Fan output step	0 - 10	Step	
122	Outdoor unit at time of error • Fan 1 speed (Only for air conditioners with DC fan)	0 - 9999	rpm	
123	Outdoor unit at time of error • Fan 2 speed (Only for air conditioners with DC fan)	0 - 9999	rpm	"0" is displayed if the air conditioner is a single-fan type.
124				
125	LEV (A) opening at time of error	0 - 500	Pulses	
126	LEV (B) opening at time of error	0 - 500	Pulses	
127				
128				
129				
130	Thermostat ON time until operation stops due to error	0 - 999	Minutes	
131				
132	FTC-Liquid pipe temperature at time of error	-39 - 88	°C	
133				
134	FTC at time of error • Actual flow water temperature <Thermostat judge temperature>	-39 - 88	°C	
135				
136				
137				
138				
139				
140				
~				
146				
147				
148				
149				
150	FTC-Actual flow water temperature	-39 - 88	°C	
151	FTC-Liquid pipe temperature	-39 - 88	°C	
152				
~				
767				

Detail Contents in Request Code

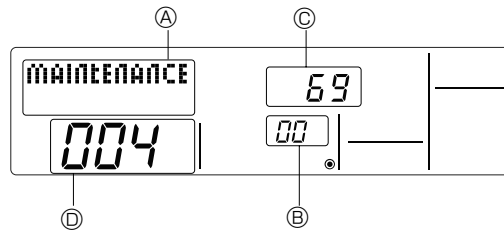

[Example) Request code "004"
Discharge temperature 69°C
Refrigerant address "00"]

A: Maintenance mode display
B: Refrigerant address
C: Data display area
D: Request code display area

[Operation state] (Request code "0")

Data display

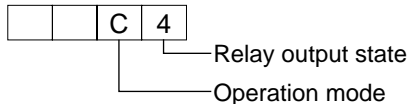

Operation mode

Display	Operation mode
0	STOP • FAN
C	COOL • DRY
H	HEAT
d	DEFROST

Relay output state

Display	Power currently supplied to compressor	Compressor	4-way valve	Solenoid valve
0	—	—	—	—
1				ON
2			ON	
3			ON	ON
4		ON		
5		ON		ON
6		ON	ON	
7		ON	ON	ON
8	ON			
A	ON		ON	

[FTC unit – Control state] (Request code : "50 ")

Data display

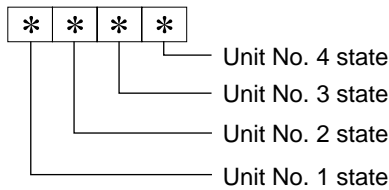

Display	State
0	Normal
1	Preparing for heat operation
2	—
3	—
4	Heater is ON.
5	Anti-freeze protection is ON.
6	Overheat protection is ON.
7	Requesting compressor to turn OFF
F	There are no corresponding units.

[Outdoor unit – Control state] (Request code "51")

Data display	State
0 0 0 0	Normal
0 0 0 1	Preparing for heat operation
0 0 0 2	Defrost

[Compressor – Frequency control state] (Request code "52")

Data display

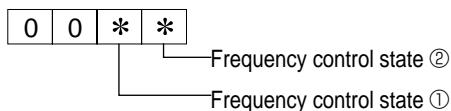

Frequency control state ①

Display	Current limit control
0	No current limit
1	Primary current limit control is ON.
2	Secondary current limit control is ON.

Frequency control state ②

Display	Discharge temperature overheat prevention	Condensation temperature overheat prevention	Anti-freeze protection control	Heatsink temperature overheat prevention
0				
1	Controlled			
2		Controlled		
3	Controlled	Controlled		
4			Controlled	
5	Controlled		Controlled	
6		Controlled	Controlled	
7	Controlled	Controlled	Controlled	
8				Controlled
9	Controlled			Controlled
A		Controlled		Controlled
b	Controlled	Controlled		Controlled
C			Controlled	Controlled
d	Controlled		Controlled	Controlled
E		Controlled	Controlled	Controlled
F	Controlled	Controlled	Controlled	Controlled

[Fan control state] (Request code : "53")

Data display

0	0	*	*
---	---	---	---

— Fan step correction value by heatsink temperature overhear prevention control
 — Fan step correction value by cool condensation temperature overhear prevention control

Display	Correction value
- (minus)	- 1
0	0
1	+1
2	+2

[Actuator output state] (Request code : "54")

Data display

0	0	*	*
---	---	---	---

— Actuator output state ①
 — Actuator output state ②

Actuator output state ①

Display	SV1	4-way valve	Compressor	Compressor is warming up
0				
1	ON			
2		ON		
3	ON	ON		
4			ON	
5	ON		ON	
6		ON	ON	
7	ON	ON	ON	
8				ON
9	ON			ON
A		ON		ON
b	ON	ON		ON
C			ON	ON
d	ON		ON	ON
E		ON	ON	ON
F	ON	ON	ON	ON

Actuator output state ②

Display	52C	SV2	SS
0			
1	ON		
2		ON	
3	ON	ON	
4			ON
5	ON		ON
6		ON	ON
7	ON	ON	ON

[Error content (U9)] (Request code : "55")

Data display

0	0	*	*
---	---	---	---

— Error content ①
 — Error content ②

Error content ①

● : Detected

Display	Oversvoltage error	Undersvoltage error	L1-phase open error	Power synchronizing signal error
0				
1	●			
2		●		
3	●	●		
4			●	
5	●		●	
6		●	●	
7	●	●	●	
8				●
9	●			●
A		●		●
b	●	●		●
C			●	●
d	●		●	●
E		●	●	●
F	●	●	●	●

Error content ②

● : Detected

Display	Converter Fo error	PAM error
0		
1	●	
2		●
3	●	●

[Contact demand capacity] (Request code "61")

Data display

0	0	0	*
---	---	---	---

 Setting content

Setting content

Display	Setting value	Setting	
		SW7-1	SW7-2
0	0%		
1	50%	ON	
2	75%		ON
3	100%	ON	ON

[External input state] (Request code "62")

Data display

0	0	0	*
---	---	---	---

 Input state

Input state

● : Input present

Display	Contact demand input	Silent mode input	Spare 1 input	Spare 2 input
0				
1	●			
2		●		
3	●	●		
4			●	
5	●		●	
6		●	●	
7	●	●	●	
8				●
9	●			●
A		●		●
b	●	●		●
C			●	●
d	●		●	●
E		●	●	●
F	●	●	●	●

[Outdoor unit - Capacity setting display] (Request code : "70")

Data display	Capacity
9	35
10	50
11	60
14	71
20	100
25	125
28	140
40	200
50	250

[Outdoor unit - Setting information] (Request code "71")

Data display

0	0	*	*
---	---	---	---

 Setting information ①
Setting information ②

Setting information ①

Display	Defrost mode
0	Standard
1	For high humidity

Setting information ②

Display	Single-/3-phase	Heat pump/cooling only
0	Single-phase	Heat pump
1		Cooling only
2	3-phase	Heat pump
3		Cooling only

[Outdoor unit switch setting display (SW1 to SW10, except SW3)] Request codes: 73 to 82

0: Switch OFF 1: Switch ON

SW1, SW2, SW6, SW7						Data display
1	2	3	4	5	6	
0	0	0	0	0	0	00 00
1	0	0	0	0	0	00 01
0	1	0	0	0	0	00 02
1	1	0	0	0	0	00 03
0	0	1	0	0	0	00 04
1	0	1	0	0	0	00 05
0	1	1	0	0	0	00 06
1	1	1	0	0	0	00 07
0	0	0	1	0	0	00 08
1	0	0	1	0	0	00 09
0	1	0	1	0	0	00 0A
1	1	0	1	0	0	00 0b
0	0	1	1	0	0	00 0C
1	0	1	1	0	0	00 0d
0	1	1	1	0	0	00 0E
1	1	1	1	0	0	00 0F
0	0	0	0	1	0	00 10
1	0	0	0	1	0	00 11
0	1	0	0	1	0	00 12
1	1	0	0	1	0	00 13
0	0	1	0	1	0	00 14
1	0	1	0	1	0	00 15
0	1	1	0	1	0	00 16
1	1	1	0	1	0	00 17
0	0	0	1	1	0	00 18
1	0	0	1	1	0	00 19
0	1	0	1	1	0	00 1A
1	1	0	1	1	0	00 1B
0	0	1	1	1	0	00 1C
1	0	1	1	1	0	00 1D
0	1	1	1	1	0	00 1E
1	1	1	1	1	0	00 1F
0	0	0	0	0	1	00 20
1	0	0	0	0	1	00 21
0	1	0	0	0	1	00 22
1	1	0	0	0	1	00 23
0	0	1	0	0	1	00 24
1	0	1	0	0	1	00 25
0	1	1	0	0	1	00 26
1	1	1	0	0	1	00 27
0	0	0	1	0	1	00 28
1	0	0	1	0	1	00 29
0	1	0	1	0	1	00 2A
1	1	0	1	0	1	00 2B
0	0	1	1	0	1	00 2C
1	0	1	1	0	1	00 2D
0	1	1	1	0	1	00 2E
1	1	1	1	0	1	00 2F
0	0	0	0	1	1	00 30
1	0	0	0	1	1	00 31
0	1	0	0	1	1	00 32
1	1	0	0	1	1	00 33
0	0	1	0	1	1	00 34
1	0	1	0	1	1	00 35
0	1	1	0	1	1	00 36
1	1	1	0	1	1	00 37
0	0	0	1	1	1	00 38
1	0	0	1	1	1	00 39
0	1	0	1	1	1	00 3A
1	1	0	1	1	1	00 3B
0	0	1	1	1	1	00 3C
1	0	1	1	1	1	00 3D
0	1	1	1	1	1	00 3E
1	1	1	1	1	1	00 3F

0: Switch OFF 1: Switch ON

SW5				Data display
1	2	3	4	
0	0	0	0	00 00
1	0	0	0	00 01
0	1	0	0	00 02
1	1	0	0	00 03
0	0	1	0	00 04
1	0	1	0	00 05
0	1	1	0	00 06
1	1	1	0	00 07
0	0	0	1	00 08
1	0	0	1	00 09
0	1	0	1	00 0A
1	1	0	1	00 0b
0	0	1	1	00 0C
1	0	1	1	00 0d
0	1	1	1	00 0E
1	1	1	1	00 0F

0: Switch OFF 1: Switch ON

SW8			Data display
1	2	3	
0	0	0	00 00
1	0	0	00 01
0	1	0	00 02
1	1	0	00 03
0	0	1	00 04
1	0	1	00 05
0	1	1	00 06
1	1	1	00 07

0: Switch OFF 1: Switch ON

SW4, SW9, SW10		Data display
1	2	
0	0	00 00
1	0	00 01
0	1	00 02
1	1	00 03



8. Outlines and dimensions

Unit : mm

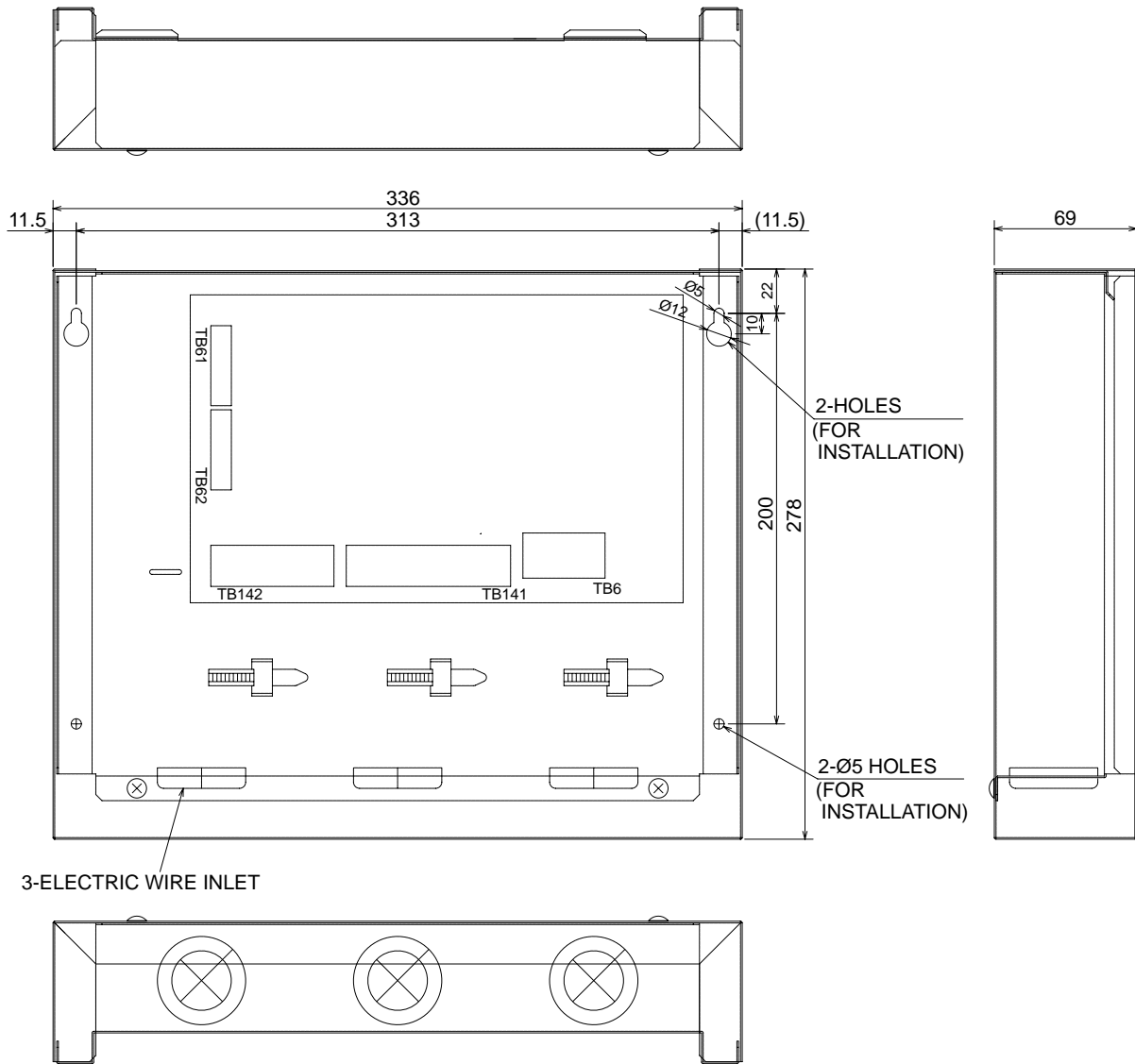

WIRED REMOTE CONTROLLER

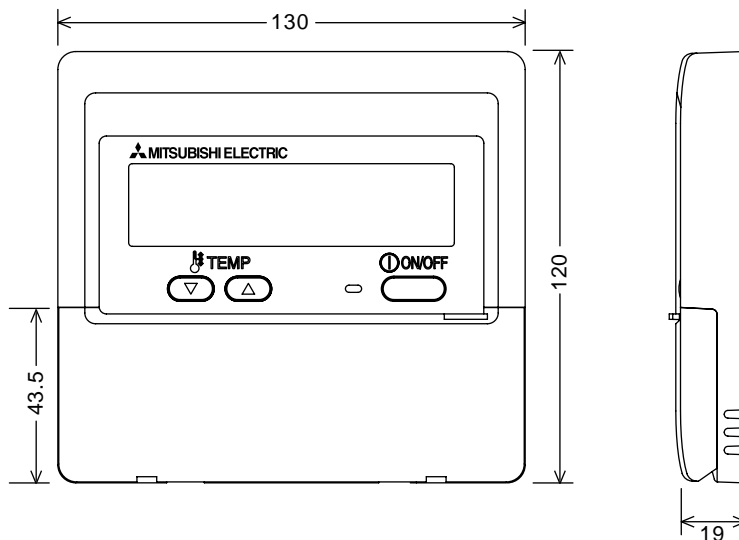

6

Requirements

6-1. For functional parts

6-1-1. Thermistor position

Refer to section 4. Interface or 5. Flow temp. controller for detail.

(1) I / F : PAC-IF011B-E (cased), PAC-IF010-E (PCB only)

Application	Capacity Control	Water HEX	Terminal "TH1" target temp.	Terminal "TH2" Pipe temp./Liquid	Terminal "TH5" Pipe temp./2-phase
Air to Water	By external STEP signals	Packaged	Fixed resistor	Fixed resistor	Open
		Split	Fixed resistor	CONNECT	Open
Air to Air	"By external STEP signals"	Split	Fixed resistor	CONNECT	CONNECT *1
		Calculate by I / F	CONNECT	CONNECT	CONNECT *1

Fixed resistor value : 4~10kΩ

*1. If the outdoor unit is ZUBADAN series, Terminal "TH5" can be opened.

(2) FTC : PAC-IF021B-E (cased), PAC-IF020-E (PCB only)

Application	Capacity Control	Water HEX	Terminal "TH1" target temp.	Terminal "TH2" Pipe temp./Liquid	Terminal "TH5" Pipe temp./2-phase
Air to Water	"By external STEP signals"	Packaged	CONNECT	Open	Open
		Split	CONNECT	CONNECT	Open

PAC-IF011B-E/PAC-IF021B-E (cased) contains 2 thermistors.

PAC-IF010B-E/PAC-IF020B-E (PCB only) doesn't contain thermistor.

Please purchase locally optional parts PAC-TH010-E ("Thermistor, 5m x 2pcs " 10set).

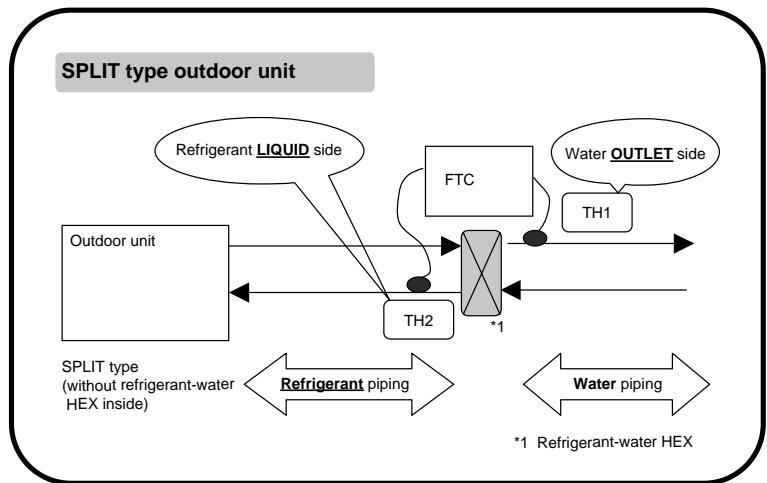
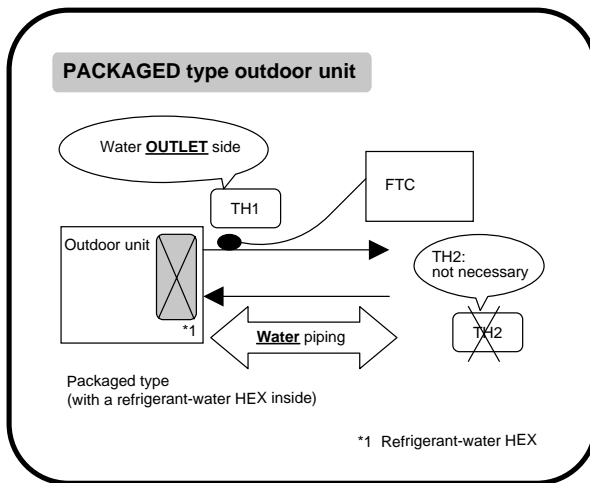

6-1-2. Mounting PCB (PCB only, uncased type)

- To comply with the required regulations and directives by your side.
 - e.g) CE marking
- Fire safty : PCB must be enclosed by sheet metal.
- Ambient temperature : 0°C ~ 60°C
- Do not install it outdoors.

6-2. For application

- Piping material/water flow velocity
- To prevent freezing
- Water quality
- Primary / secondary water

Refer to 2-2-2 [6] Notification to design / select HEX (Refrigerant - Water)

1. Air to Water application

(1) Domestic Hot Water + Space heating by radiator with packaged outdoor unit + FTC

*variable capacity request signals for Heat Pump is calculated by FTC.

1) System outline

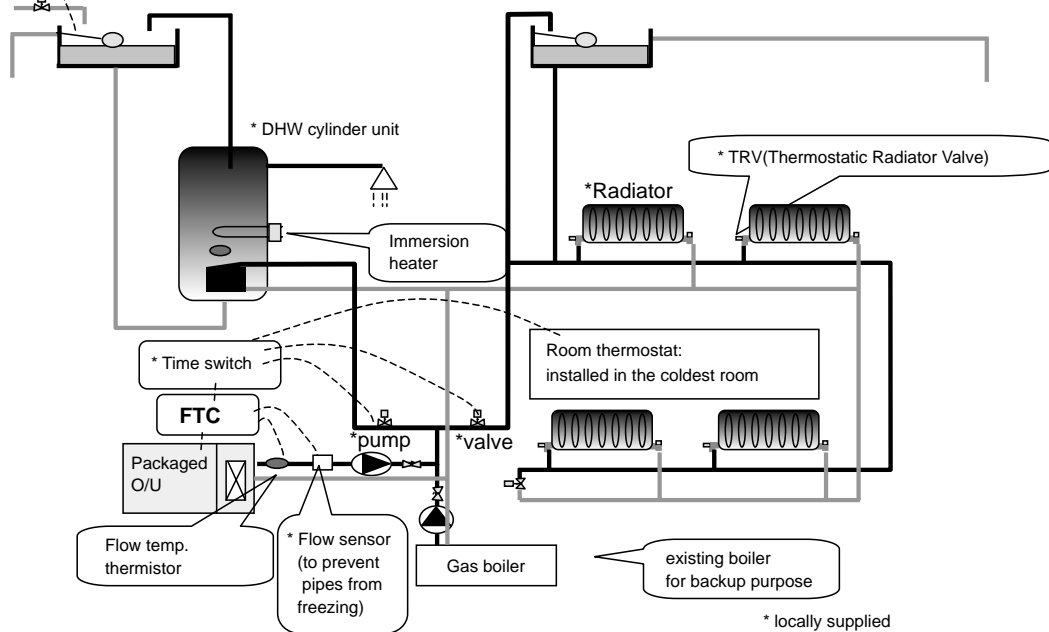

2) Wiring / Switch setting

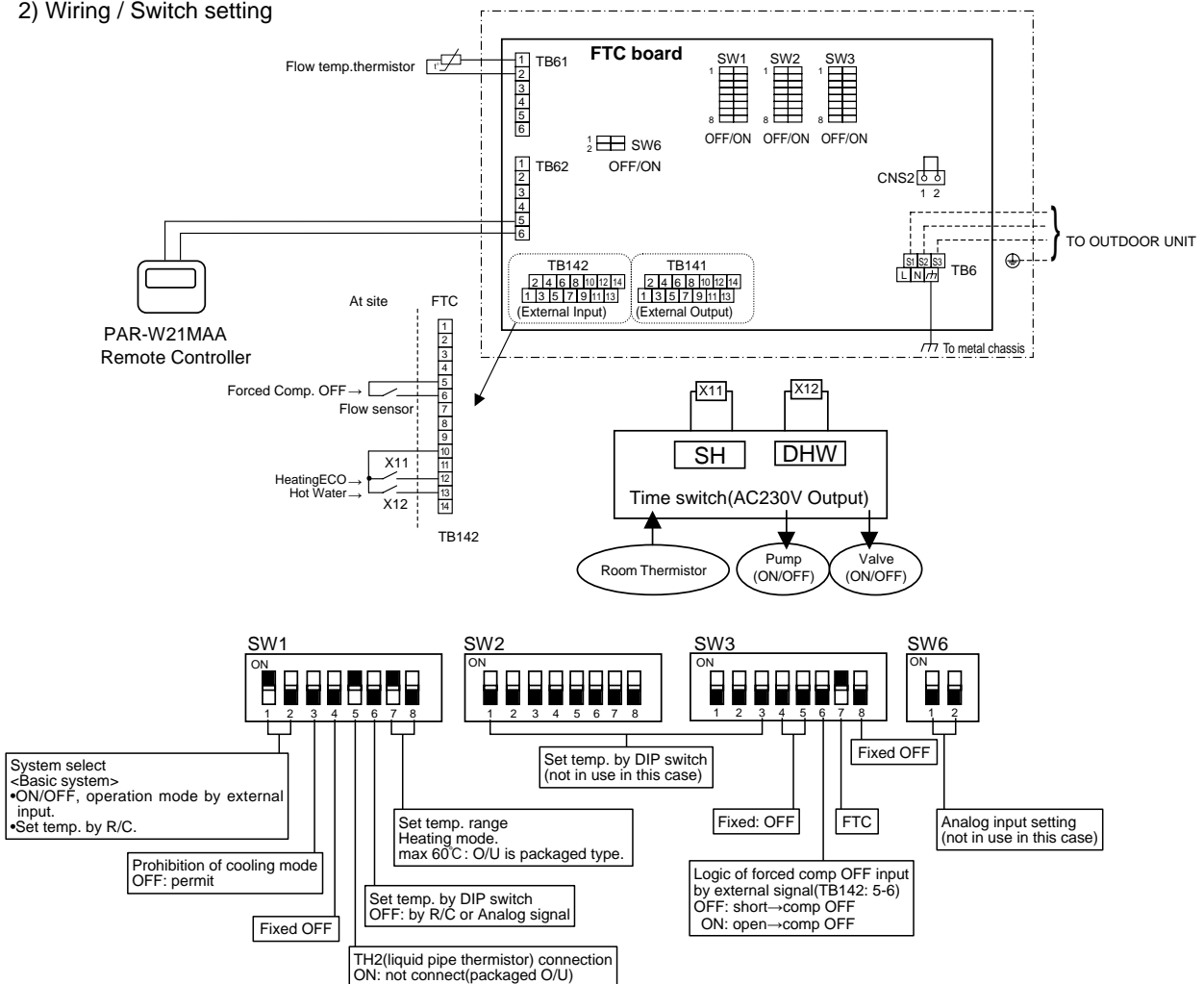

**(2)-1. Space heating by under floor heating
with split outdoor unit+HYDROBOX + FTC**
*variable capacity request signals for Heat Pump is calculated by FTC.

1) System outline

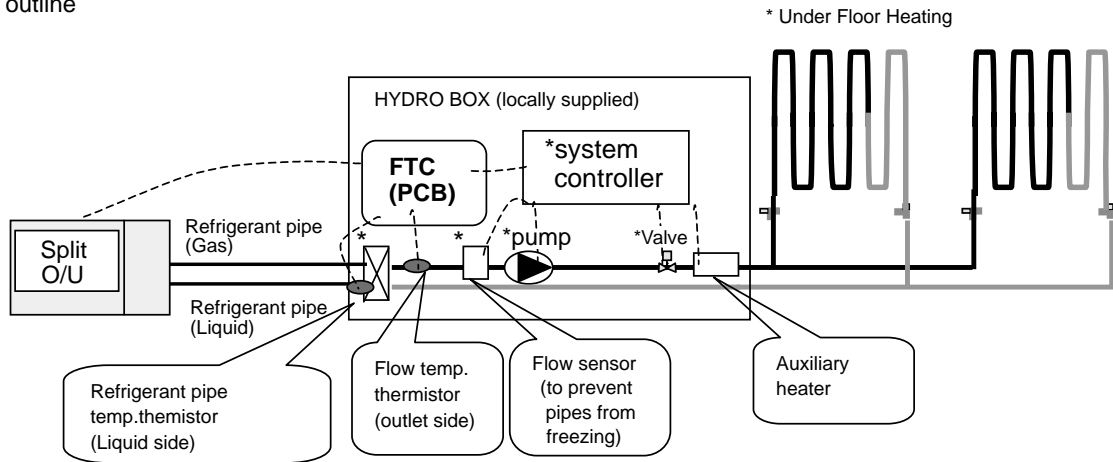

* locally supplied

2) Wiring / Switch setting

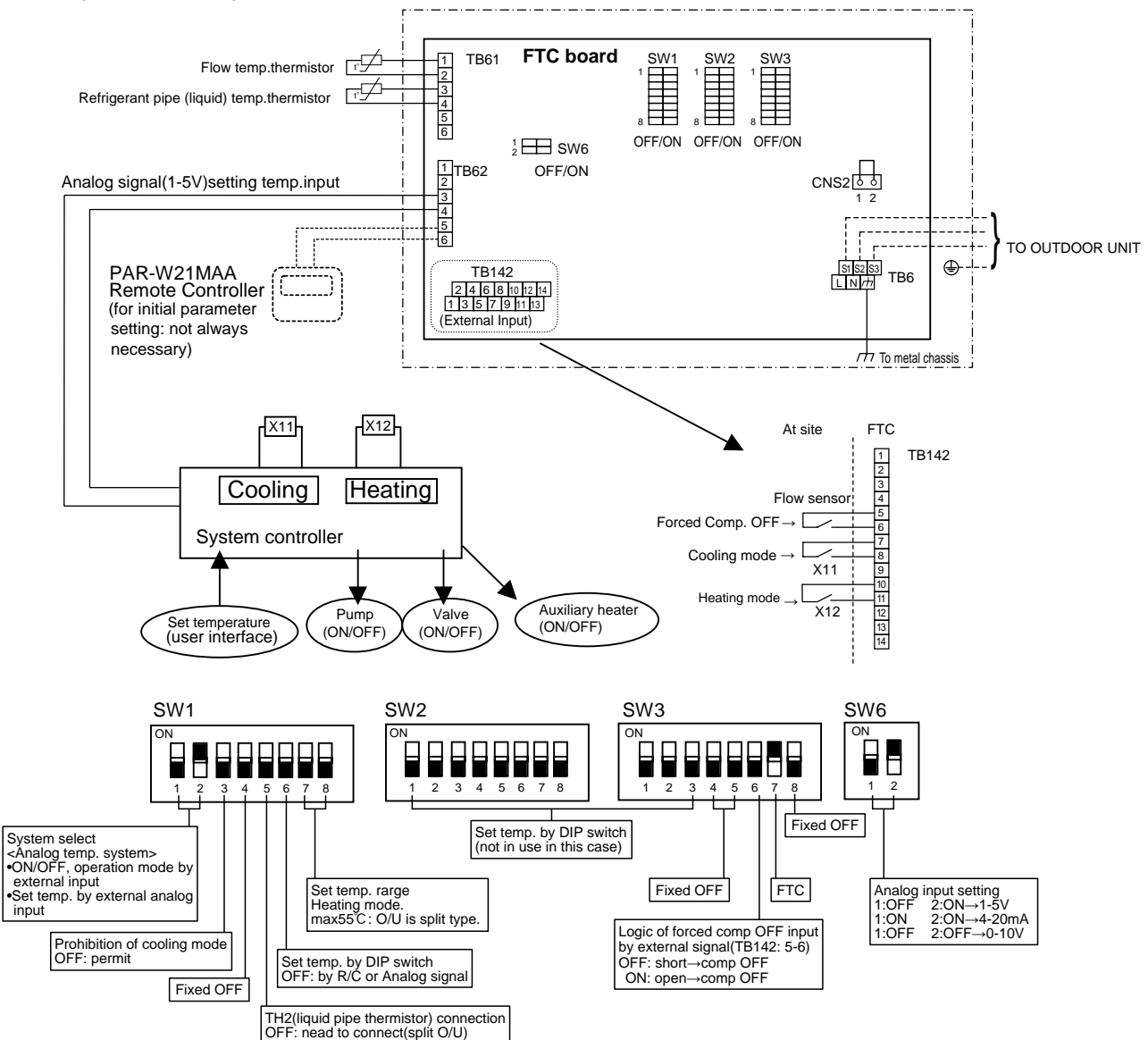

(2)-2. Domestic Hot Water + space heating by under floor heating with split outdoor unit+HYDROBOX + IF

*variable capacity request signals for Heat Pump is calculated by local system controller.

1) System outline

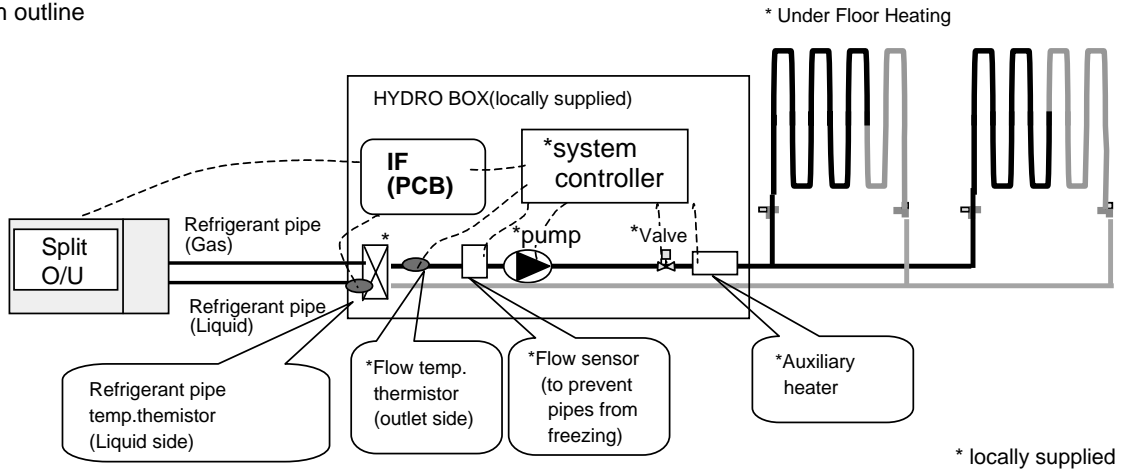

* locally supplied

2) Wiring / Switch setting

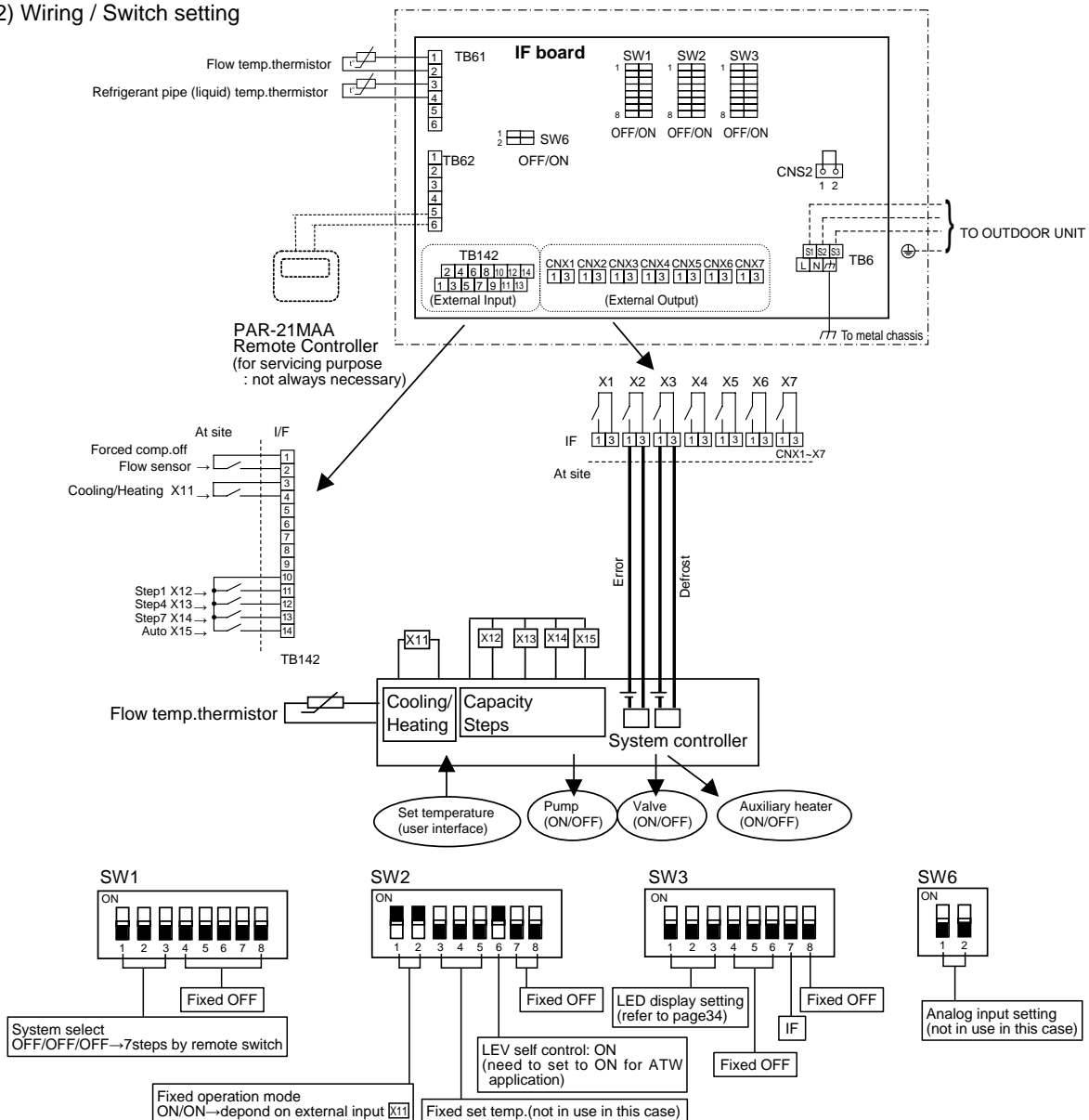

2. Air to Air application

Air-Handling Unit with split outdoor unit + IF

*variable capacity request signals for Heat Pump is calculated by IF.

1) System outline

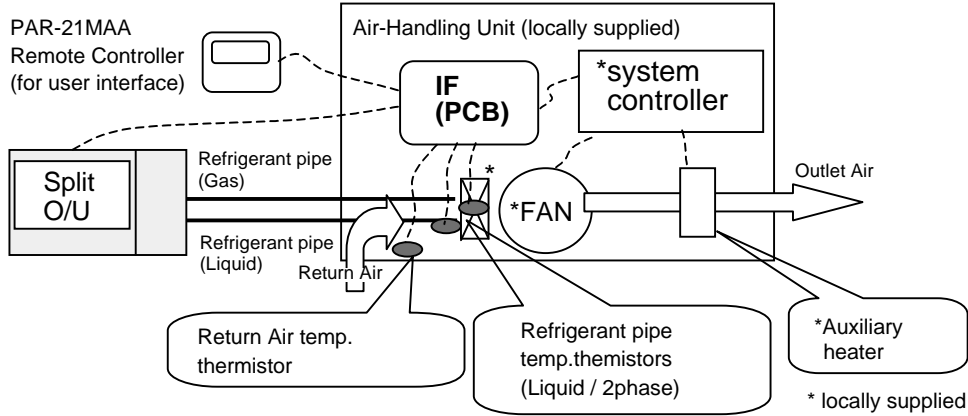

2) Wiring / Switch setting

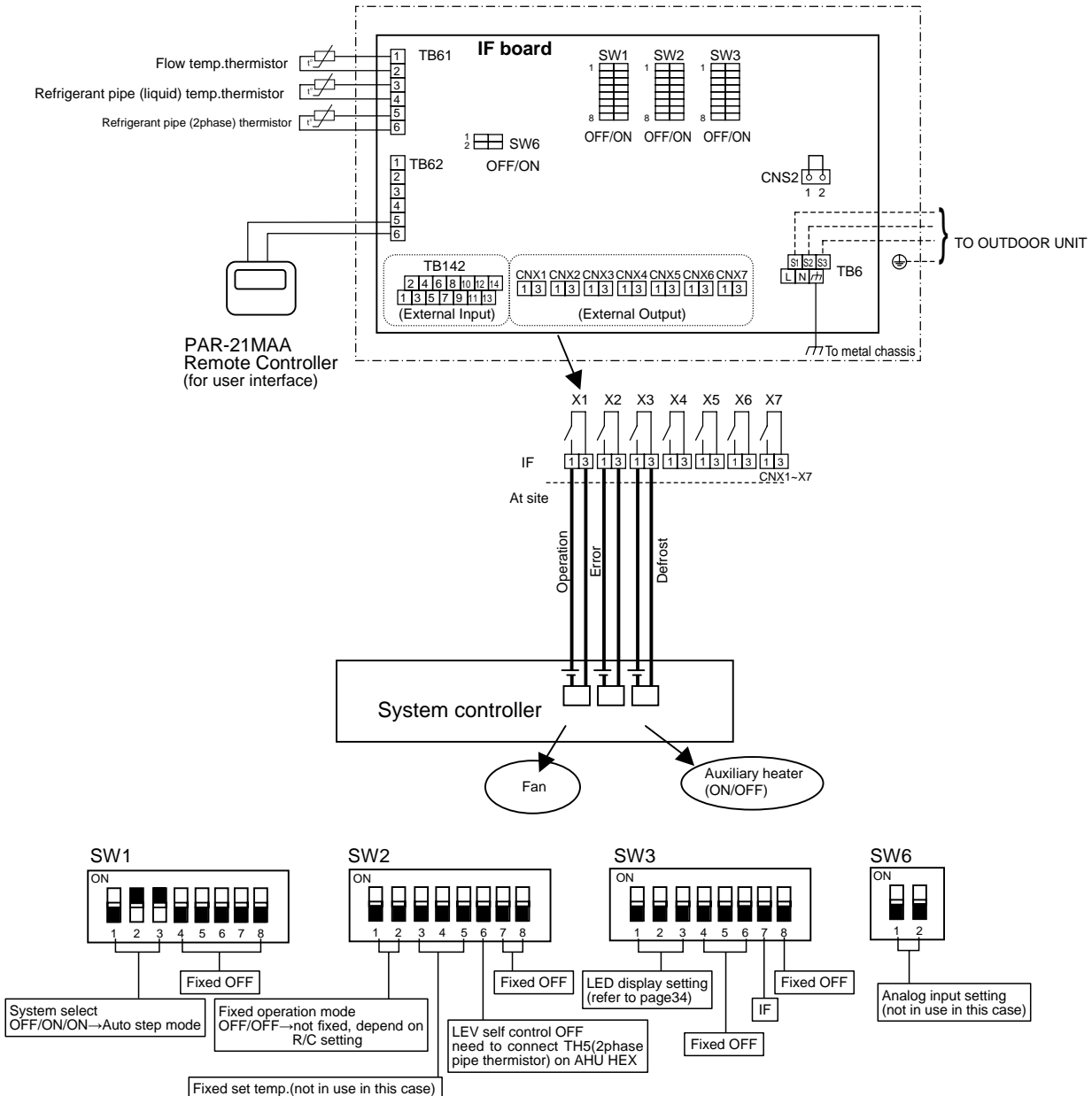

Air to Water (ATW) Heat pump, Interface (I/F) and Flow temp. controller (FTC) Technical manual

