

SPLIT-TYPE, HEAT PUMP AIR CONDITIONERS  
SPLIT-TYPE, AIR CONDITIONERS

September 2012

No. OCH416

REVISED EDITION-D

# SERVICE MANUAL

## Series PLA Ceiling Cassettes R410A

Indoor unit

[Model names]

[Service Ref.]

PLA-RP35BA

PLA-RP35BA

PLA-RP35BA<sub>1</sub> PLA-RP35BAR1

PLA-RP50BA

PLA-RP50BA

PLA-RP50BA<sub>1</sub> PLA-RP50BAR1

PLA-RP60BA

PLA-RP60BA

PLA-RP60BA<sub>1</sub> PLA-RP60BAR1

PLA-RP71BA

PLA-RP71BA

PLA-RP71BA<sub>1</sub> PLA-RP71BAR1

PLA-RP100BA

PLA-RP100BA

PLA-RP125BA

PLA-RP125BA

PLA-RP140BA

PLA-RP140BA

Revision:

- PLA-RP35/50/60/71BAR1 have been added in REVISED EDITION-D.
- Some descriptions have been modified.

- Please void OCH416 REVISED EDITION-C.

Note:

- This manual describes only service data of the indoor units.
- RoHS compliant products have <G> mark on the spec name plate.

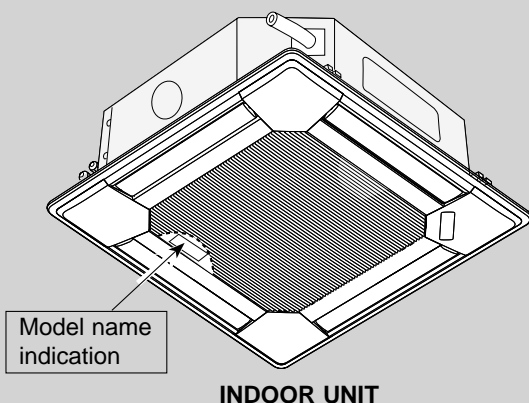

WIRELESS REMOTE CONTROLLER

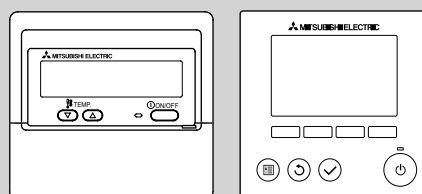

WIRED REMOTE CONTROLLER

### CONTENTS

1. TECHNICAL CHANGES.....	2
2. REFERENCE MANUAL.....	2
3. SAFETY PRECAUTION.....	3
4. PART NAMES AND FUNCTIONS.....	4
5. SPECIFICATIONS.....	12
6. NOISE CRITERION CURVES.....	15
7. OUTLINES AND DIMENSIONS.....	17
8. WIRING DIAGRAM.....	18
9. REFRIGERANT SYSTEM DIAGRAM.....	19
10. TROUBLESHOOTING.....	20
11. SPECIAL FUNCTION.....	35
12. DISASSEMBLY PROCEDURE.....	42

### PARTS CATALOG (OCB416)

Mr. SLIM™

# 1

## TECHNICAL CHANGES

Service ref. have been changed as follows.

PLA-RP35BA<sub>1</sub> → PLA-RP35BAR1  
 PLA-RP50BA<sub>1</sub> → PLA-RP50BAR1  
 PLA-RP60BA<sub>1</sub> → PLA-RP60BAR1  
 PLA-RP71BA<sub>1</sub> → PLA-RP71BAR1

### PLP-6BAJ (Auto descending panel, option)

The controller board (U.B) has been changed. (only for the panel but not for the service part)

PLA-RP35BA → PLA-RP35BA<sub>1</sub>  
 PLA-RP50BA → PLA-RP50BA<sub>1</sub>  
 PLA-RP60BA → PLA-RP60BA<sub>1</sub>  
 PLA-RP71BA → PLA-RP71BA<sub>1</sub>

- FAN MOTOR (MF) has been changed.
- TURBO FAN, NUT and WASHER have been changed.

# 2

## REFERENCE MANUAL

### 2-1. OUTDOOR UNIT'S SERVICE MANUAL

Service Ref	Service Manual No.
SUZ-KA60/71VA3.TH-A	OCH511 OCB511
PUHZ-RP71/100/125/140VHA <sub>(1)</sub> -A	OC337
PUHZ-RP200/250YHA <sub>(1)</sub> -A	OC339
SUZ-KA60/71VA <sub>(1)</sub> .TH-A SUZ-KA60VAR2.TH-A	OC323
PUHZ-RP71/100/125/140VHA2(#1)-A PUHZ-RP100/125/140YHA2(#1)-A	OCH422 OCB422
PUHZ-BP100/125/140VHA-A PUHZ-BP200/250YHA-A	OCH423 OCB423
MXZ-8A140VA <sub>2</sub> /VA <sub>3</sub>	OC316

### 2-2. TECHNICAL DATA BOOK

Series (Outdoor unit)	Data Book No.
PUHZ-RP•HA2	OCS09
PUHZ-BP•HA	OCS10

## CAUTIONS RELATED TO NEW REFRIGERANT

## Cautions for units utilising refrigerant R410A

**Use new refrigerant pipes.**

In case of using the existing pipes for R22, be careful with the followings.

- For RP100, 125 and 140, be sure to perform replacement operation before test run.
- Change flare nut to the one provided with this product. Use a newly flared pipe.
- Avoid using thin pipes.

**Make sure that the inside and outside of refrigerant piping is clean and it has no contaminants such as sulfur, oxides, dirt, shaving particles, etc, which are hazard to refrigerant cycle. In addition, use pipes with specified thickness.**

Contamination inside refrigerant piping can cause deterioration of refrigerant oil etc.

**Store the piping indoors and keep both ends of the piping sealed until just before brazing. (Leave elbow joints, etc. in their packaging.)**

If dirt, dust or moisture enters into refrigerant cycle, that can cause deterioration of refrigerant oil or malfunction of compressor.

**The refrigerant oil applied to flares and flange connections must be ester oil, ether oil or alkylbenzene oil in a small amount.**

If large amount of mineral oil enters, that can cause deterioration of refrigerant oil etc.

**Charge refrigerant from liquid phase of gas cylinder.**

If the refrigerant is charged from gas phase, composition change may occur in refrigerant and the efficiency will be lowered.

**Do not use refrigerant other than R410A.**

If other refrigerant (R22 etc.) is used, chlorine in refrigerant can cause deterioration of refrigerant oil etc.

**Use a vacuum pump with a reverse flow check valve.**

Vacuum pump oil may flow back into refrigerant cycle and that can cause deterioration of refrigerant oil etc.

**Use the following tools specifically designed for use with R410A refrigerant.**

The following tools are necessary to use R410A refrigerant.

Tools for R410A	
Gauge manifold	Flare tool
Charge hose	Size adjustment gauge
Gas leak detector	Vacuum pump adaptor
Torque wrench	Electronic refrigerant charging scale

**Handle tools with care.**

If dirt, dust or moisture enters into refrigerant cycle, that can cause deterioration of refrigerant oil or malfunction of compressor.

**Do not use a charging cylinder.**

If a charging cylinder is used, the composition of refrigerant will change and the efficiency will be lowered.

**Use the specified refrigerant only.**

**Never use any refrigerant other than that specified.** Doing so may cause a burst, an explosion, or fire when the unit is being used, serviced, or disposed of. Correct refrigerant is specified in the manuals and on the spec labels provided with our products. We will not be held responsible for mechanical failure, system malfunction, unit breakdown or accidents caused by failure to follow the instructions.

**Ventilate the room if refrigerant leaks during operation. If refrigerant comes into contact with a flame, poisonous gases will be released.**

**[1] Cautions for service**

- (1) Perform service after recovering the refrigerant left in unit completely.
- (2) Do not release refrigerant in the air.
- (3) After completing service, charge the cycle with specified amount of refrigerant.
- (4) When performing service, install a filter drier simultaneously.  
Be sure to use a filter drier for new refrigerant.

**[2] Additional refrigerant charge**

**When charging directly from cylinder**

- Check that cylinder for R410A available on the market is syphon type.
- Charging should be performed with the cylinder of syphon stood vertically. (Refrigerant is charged from liquid phase.)

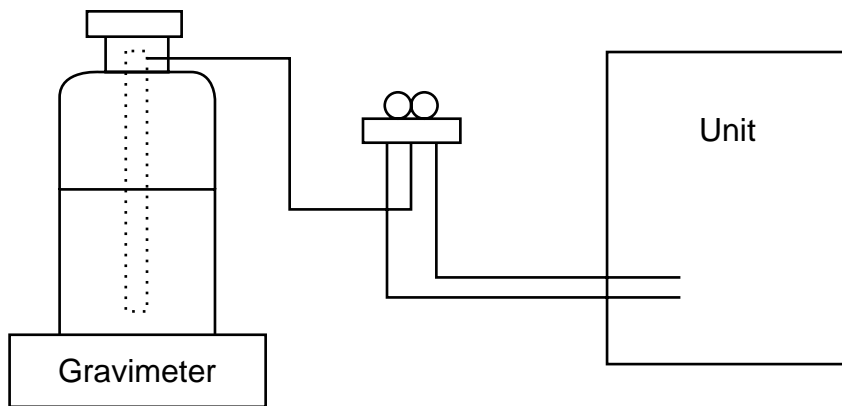

### [3] Service tools

Use the below service tools as exclusive tools for R410A refrigerant.

No.	Tool name	Specifications
①	Gauge manifold	<ul style="list-style-type: none"> <li>· Only for R410A</li> <li>· Use the existing fitting specifications. (UNF1/2)</li> <li>· Use high-tension side pressure of 5.3MPa·G or over.</li> </ul>
②	Charge hose	<ul style="list-style-type: none"> <li>· Only for R410A</li> <li>· Use pressure performance of 5.09MPa·G or over.</li> </ul>
③	Electronic scale	—
④	Gas leak detector	· Use the detector for R134a, R407C or R410A.
⑤	Adaptor for reverse flow check	· Attach on vacuum pump.
⑥	Refrigerant charge base	—
⑦	Refrigerant cylinder	<ul style="list-style-type: none"> <li>· Only for R410A</li> <li>· Top of cylinder (Pink)</li> <li>· Cylinder with syphon</li> </ul>
⑧	Refrigerant recovery equipment	—

## 4 PART NAMES AND FUNCTIONS

### 4-1. INDOOR UNIT

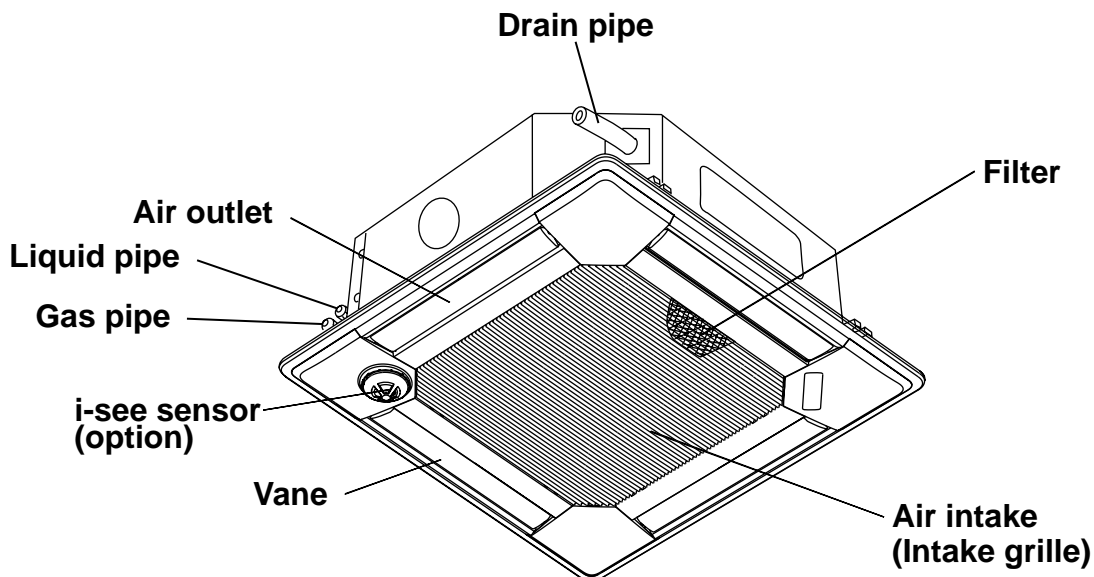

## 4-2. WIRELESS REMOTE CONTROLLER

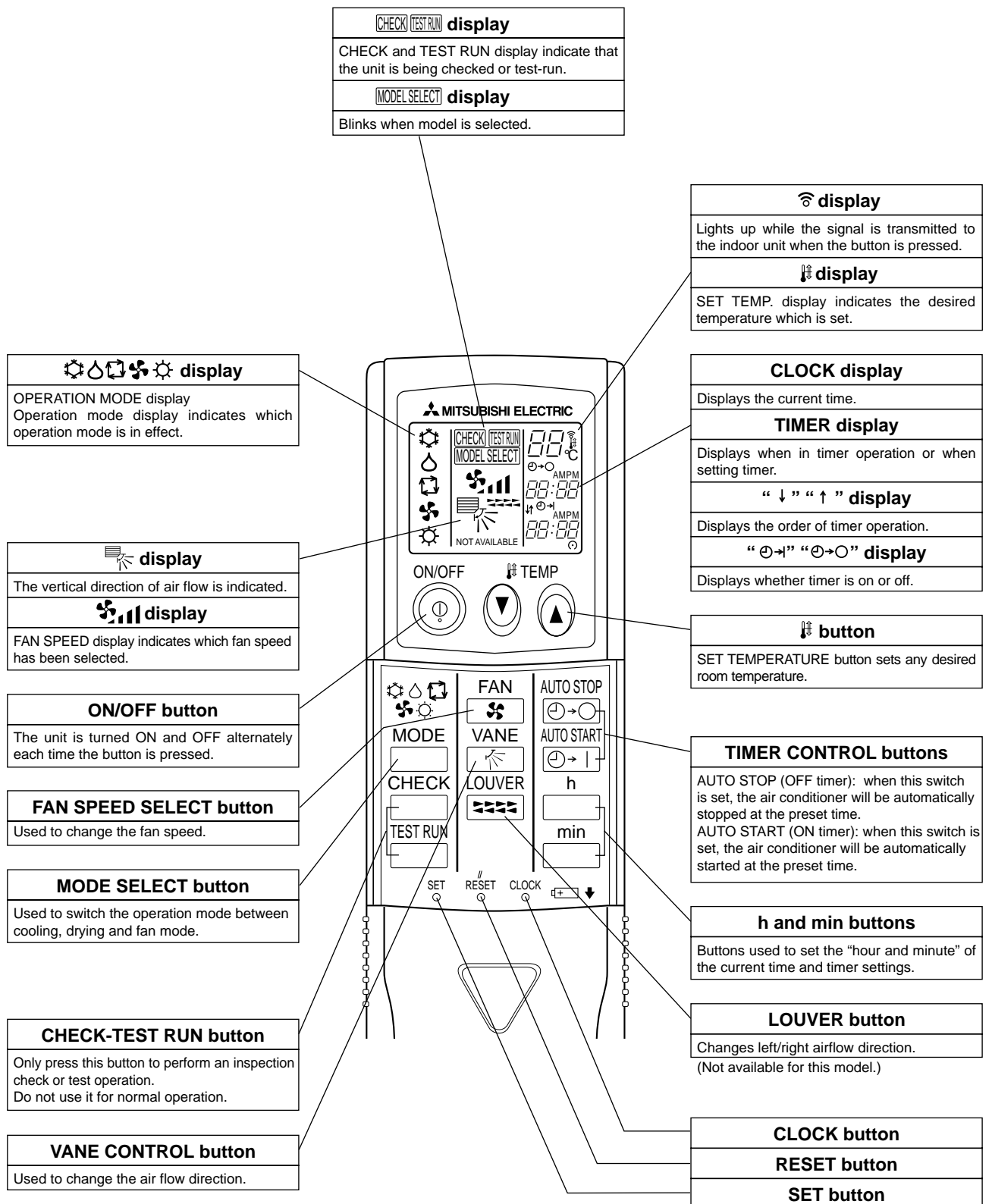

## 4-3. WIRED REMOTE CONTROLLER <PAR-30MAA>

### Wired remote controller function

\* The functions which can be used are restricted according to the model.

○ : Supported × : Unsupported

	Function	PAR-30MAA		PAR-21MAA
		Slim	City multi	
Body	Product size H x W x D (mm)	120 x 120 x 19		120 x 130 x 19
	LCD	Full Dot LCD		Partial Dot LCD
	Backlight	○		×
Energy-saving	Energy-saving operation schedule	○	×	×
	Automatic return to the preset temperature	○		×
Restriction	Setting the temperature range restriction	○		○
Function	Operation lock function	○		○
	Weekly timer	○		×
	On / Off timer	○		○
	High Power	○	×	×
	Manual vane angle	○		○

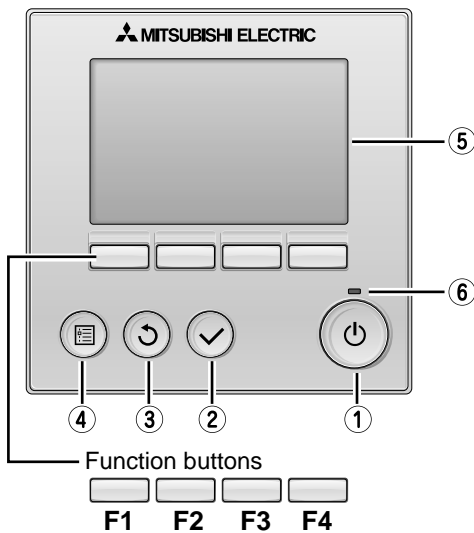

The functions of the function buttons change depending on the screen. Refer to the button function guide that appears at the bottom of the LCD for the functions they serve on a given screen.

When the system is centrally controlled, the button function guide that corresponds to the locked button will not appear.

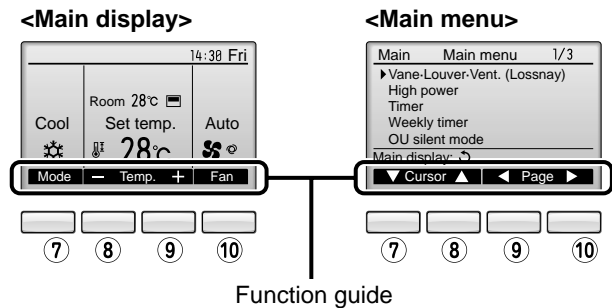

#### ① ON / OFF button

Press to turn ON/OFF the indoor unit.

#### ② SELECT button

Press to save the setting.

#### ③ RETURN button

Press to return to the previous screen.

#### ④ MENU button

Press to bring up the Main menu.

#### ⑤ Backlit LCD

Operation settings will appear.  
When the backlight is off, pressing any button turns the backlight on and it will stay lit for a certain period of time depending on the screen.

**When the backlight is off, pressing any button turns the backlight on and does not perform its function. (except for the  (ON / OFF) button)**

#### ⑥ ON / OFF lamp

This lamp lights up in green while the unit is in operation. It blinks while the remote controller is starting up or when there is an error.

#### ⑦ Function button **F1**

Main display : Press to change the operation mode.  
Main menu : Press to move the cursor down.

#### ⑧ Function button **F2**

Main display : Press to decrease temperature.  
Main menu : Press to move the cursor up.

#### ⑨ Function button **F3**

Main display : Press to increase temperature.  
Main menu : Press to go to the previous page.

#### ⑩ Function button **F4**

Main display : Press to change the fan speed.  
Main menu : Press to go to the next page.

The main display can be displayed in two different modes: "Full" and "Basic".  
The factory setting is "Full". To switch to the "Basic" mode, change the setting on the Main display setting.

**<Full mode>**

\* All icons are displayed for explanation.

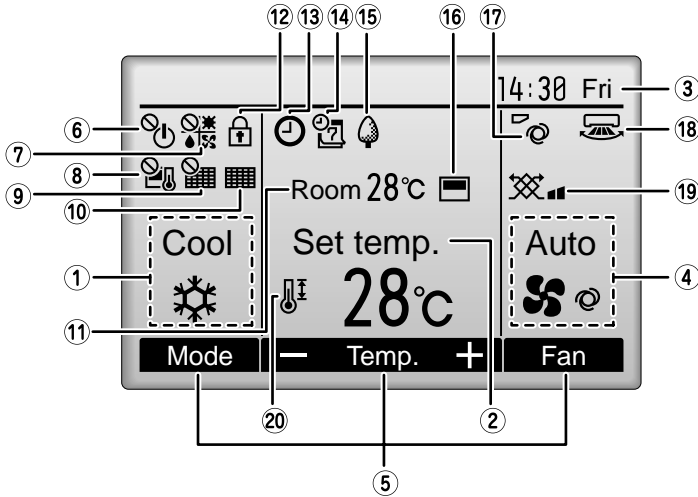

**<Basic mode>**

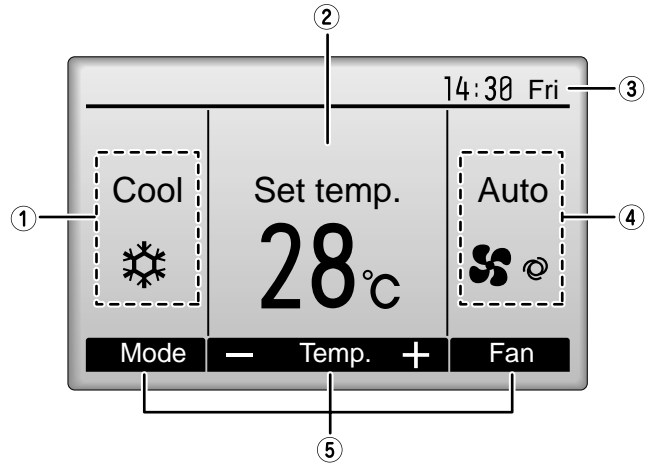

**① Operation mode**

Indoor unit operation mode appears here.

**② Preset temperature**

Preset temperature appears here.

**③ Clock (See the Installation Manual.)**

Current time appears here.

**④ Fan speed**

Fan speed setting appears here.

**⑤ Button function guide**

Functions of the corresponding buttons appear here.

**⑥**

Appears when the ON/OFF operation is centrally controlled.

**⑦**

Appears when the operation mode is centrally controlled.

**⑧**

Appears when the preset temperature is centrally controlled.

**⑨**

Appears when the filter reset function is centrally controlled.

**⑩**

Indicates when filter needs maintenance.

**⑪ Room temperature (See the Installation Manual.)**

Current room temperature appears here.

**⑫**

Appears when the buttons are locked.

**⑬**

Appears when the On/Off timer or Night setback function is enabled.

**⑭**

Appears when the Weekly timer is enabled.

**⑮**

Appears while the units are operated in the energy-save mode.

**⑯**

Appears when the built-in thermistor on the remote controller is activated to monitor the room temperature (a).

appears when the thermistor on the indoor unit is activated to monitor the room temperature.

**⑰**

Indicates the vane setting.

**⑱**

Indicates the louver setting.

**⑲**

Indicates the ventilation setting.

**⑳**

Appears when the preset temperature range is restricted.

**Most settings (except ON / OFF, mode, fan speed, temperature) can be made from the Menu screen.**

## Menu structure

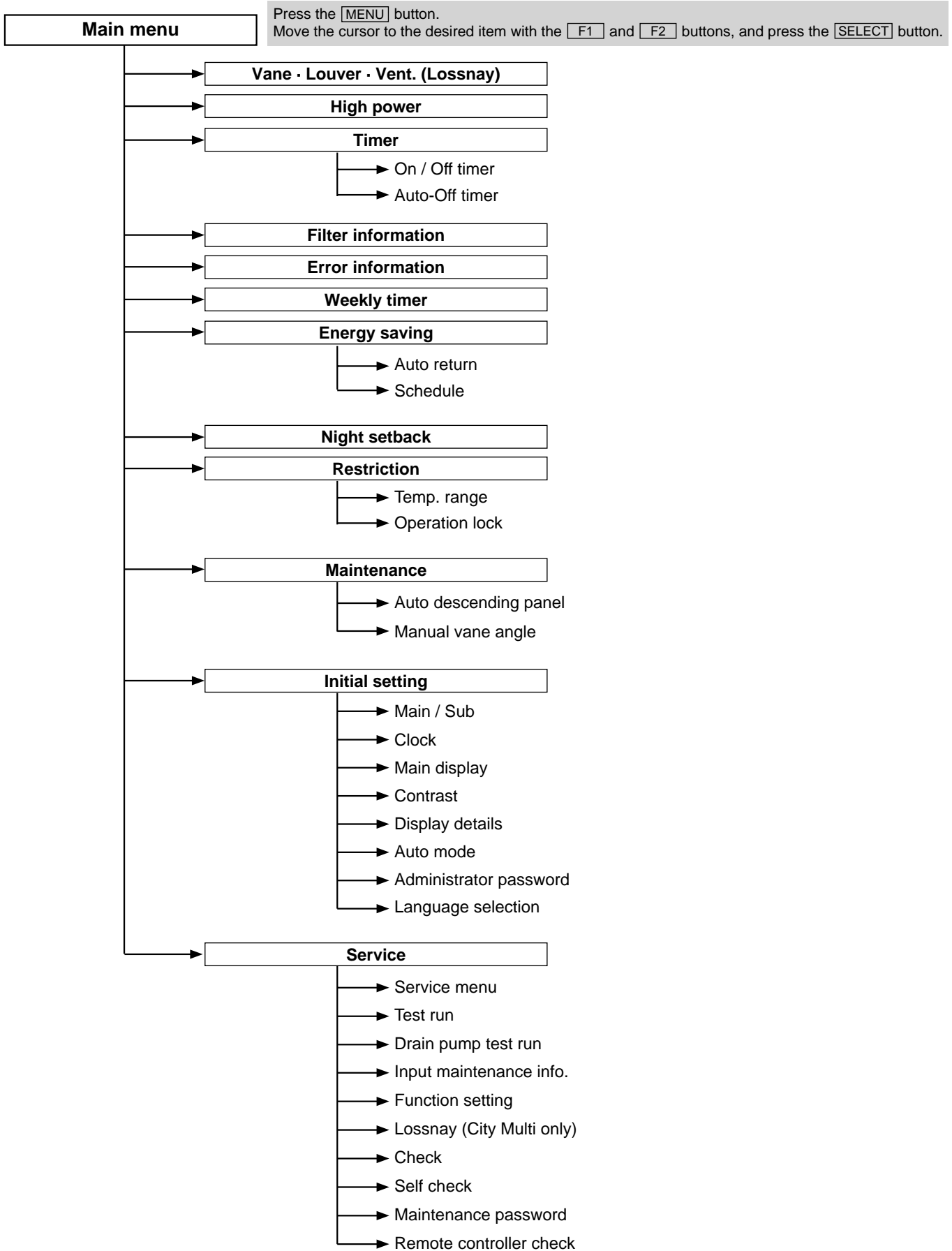

Not all functions are available on all models of indoor units.





## Main menu list

Setting and display items		Setting details
Vane · Louver · Vent. (Lossnay)		<p><b>Use to set the vane angle.</b></p> <ul style="list-style-type: none"> <li>• Select a desired vane setting from five different settings.</li> </ul> <p><b>Use to turn ON / OFF the louver.</b></p> <ul style="list-style-type: none"> <li>• Select a desired setting from "ON" and "OFF."</li> </ul> <p><b>Use to set the amount of ventilation.</b></p> <ul style="list-style-type: none"> <li>• Select a desired setting from "Off," "Low," and "High."</li> </ul>
High power		<p><b>Use to reach the comfortable room temperature quickly.</b></p> <ul style="list-style-type: none"> <li>• Units can be operated in the High-power mode for up to 30 minutes.</li> </ul>
Timer	On/Off timer	<p><b>Use to set the operation On/Off times.</b></p> <ul style="list-style-type: none"> <li>• Time can be set in 5-minute increments.</li> <li>* Clock setting is required.</li> </ul>
	Auto-Off timer	<p><b>Use to set the Auto-Off time.</b></p> <ul style="list-style-type: none"> <li>• Time can be set to a value from 30 to 240 in 10-minute increments.</li> </ul>
Filter information		<p><b>Use to check the filter status.</b></p> <ul style="list-style-type: none"> <li>• The filter sign can be reset.</li> </ul>
Error information		<p><b>Use to check error information when an error occurs.</b></p> <ul style="list-style-type: none"> <li>• Error code, error source, refrigerant address, unit model, manufacturing number, contact information (dealer's phone number) can be displayed.</li> <li>* The unit model, manufacturing number, and contact information need to be registered in advance to be displayed.</li> </ul>
Weekly timer		<p><b>Use to set the weekly operation On / Off times.</b></p> <ul style="list-style-type: none"> <li>• Up to eight operation patterns can be set for each day.</li> <li>* Clock setting is required.</li> <li>* Not valid when the On/Off timer is enabled.</li> </ul>
Energy saving	Auto return	<p><b>Use to get the units to operate at the preset temperature after performing energy-save operation for a specified time period.</b></p> <ul style="list-style-type: none"> <li>• Time can be set to a value from 30 and 120 in 10-minute increments.</li> <li>* This function will not be valid when the preset temperature ranges are restricted.</li> </ul>
	Schedule	<p><b>Set the start/stop times to operate the units in the energy-save mode for each day of the week, and set the energy-saving rate.</b></p> <ul style="list-style-type: none"> <li>• Up to four energy-save operation patterns can be set for each day.</li> <li>• Time can be set in 5-minute increments.</li> <li>• Energy-saving rate can be set to a value from 0% and 50 to 90% in 10% increments.</li> <li>* Clock setting is required.</li> </ul>
Night setback		<p><b>Use to make Night setback settings.</b></p> <ul style="list-style-type: none"> <li>• Select "Yes" to enable the setting, and "No" to disable the setting. The temperature range and the start/stop times can be set.</li> <li>* Clock setting is required.</li> </ul>
Restriction	Temp. range	<p><b>Use to restrict the preset temperature range.</b></p> <ul style="list-style-type: none"> <li>• Different temperature ranges can be set for different operation modes.</li> </ul>
	Operation lock	<p><b>Use to lock selected functions.</b></p> <ul style="list-style-type: none"> <li>• The locked functions cannot be operated.</li> </ul>
Maintenance	Auto descending panel	<p><b>Auto descending panel (Optional parts) Up / Down you can do.</b></p>
	Manual vane angle	<p><b>Use to set the vane angle for each vane to a fixed position.</b></p>
Initial setting	Main/Sub	<p><b>When connecting two remote controllers, one of them needs to be designated as a sub controller.</b></p>
	Clock	<p><b>Use to set the current time.</b></p>
	Main display	<p><b>Use to switch between "Full" and "Basic" modes for the Main display.</b></p> <ul style="list-style-type: none"> <li>• The default setting is "Full."</li> </ul>
	Contrast	<p><b>Use to adjust screen contrast.</b></p>



Setting and display items		Setting details
Initial setting	Display details	<p><b>Make the settings for the remote controller related items as necessary.</b></p> <p><b>Clock:</b> The factory settings are "Yes" and "24h" format.</p> <p><b>Temperature:</b> Set either Celsius (°C) or Fahrenheit (°F).</p> <p><b>Room temp. :</b> Set Show or Hide.</p> <p><b>Auto mode:</b> Set the Auto mode display or Only Auto display.</p>
	Auto mode	<p><b>Whether or not to use the AUTO mode can be selected by using the button.</b></p> <p><b>This setting is valid only when indoor units with the AUTO mode function are connected.</b></p>
	Administrator password	<p><b>The administrator password is required to make the settings for the following items.</b></p> <ul style="list-style-type: none"> <li>• Timer setting</li> <li>• Energy-save setting</li> <li>• Weekly timer setting</li> <li>• Restriction setting</li> <li>• Outdoor unit silent mode setting</li> <li>• Night set back</li> </ul>
	Language selection	<p><b>Use to select the desired language.</b></p>
Service	Test run	<p><b>Select "Test run" from the Service menu to bring up the Test run menu.</b></p> <ul style="list-style-type: none"> <li>• Test run</li> <li>• Drain pump test run</li> </ul>
	Input maintenance	<p><b>Select "Input maintenance Info." from the Service menu to bring up the Maintenance information screen.</b></p> <p><b>The following settings can be made from the Maintenance Information screen.</b></p> <ul style="list-style-type: none"> <li>• Model name input</li> <li>• Serial No. input</li> <li>• Dealer information input</li> </ul>
	Function setting	<p><b>Make the settings for the indoor unit functions via the remote controller as necessary.</b></p>
	LOSSNAY setting (City Multi only)	<p><b>This setting is required only when the operation of City Multi units is interlocked with LOSSNAY units.</b></p>
	Check	<p><b>Error history:</b> Display the error history and execute delete error history.</p> <p><b>Refrigerant leak check:</b> Refrigerant leaks can be judged.</p> <p><b>Smooth maintenance:</b> The indoor and outdoor maintenance data can be displayed.</p> <p><b>Request cord:</b> Details of the operation data including each thermistor temperature and error history can be checked.</p>
	Self check	<p><b>Error history of each unit can be checked via the remote controller.</b></p>
	Maintenance password	<p><b>Take the following steps to change the maintenance password.</b></p>
	Remote controller check	<p><b>When the remote controller does not work properly, use the remote controller checking function to troubleshoot the problem.</b></p>

## 4-4. WIRED REMOTE CONTROLLER <PAR-21MAA>

### Display Section

For purposes of this explanation, all parts of the display are shown. During actual operation, only the relevant items will be lit.

**Identifies the current operation**  
Shows the operating mode, etc.  
\*Multilanguage display is available.

**"Centrally Controlled" indicator**  
Indicates that operation from the remote controller has been prohibited by a master controller.

**"Timer is Off" indicator**  
Indicates that the timer is off.

**Temperature Setting**  
Shows the target temperature.

**Day-of-Week**  
Shows the current day of the week.

**Time/Timer Display**  
Shows the current time, unless the simple or Auto Off timer is set.  
If the simple or Auto Off timer is set, the time to be switched off is shown.

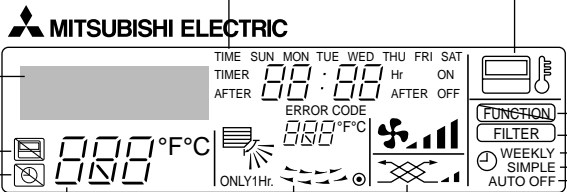

**"Sensor" indication**  
Displays when the remote controller sensor is used.

**"Locked" indicator**  
Indicates that remote controller buttons have been locked.

**"Clean The Filter" indicator**  
Displayed when it is time to clean the filter.

**Timer indicators**  
The indicator comes on if the corresponding timer is set.

**Fan Speed indicator**  
Shows the selected fan speed.

**Ventilation indicator**  
Appears when the unit is running in Ventilation mode.

**Up/Down Air Direction indicator**  
The indicator \ shows the direction of the outgoing airflow.

**Room Temperature display**  
Shows the room temperature. The room temperature display range is 8–39°C. The display blinks if the temperature is lower than 8°C or 39°C or higher.

**"One Hour Only" indicator**  
Displays if the airflow is set to low or downward during COOL or DRY mode. (Operation varies according to model.)  
The indicator goes off in 1 hour, when the airflow direction also changes.

**Louver display**  
Indicates the action of the swing louver. Does not appear if the louver is not running.

**(Power On indicator)**  
Indicates that the power is on.

### Operation Section

Temperature setting buttons

- ▽ Down
- △ Up

Timer Menu button (Monitor/Set button)

Mode button (Return button)

Set Time buttons

- ▽ Back
- △ Ahead

Timer On/Off button (Set Day button)

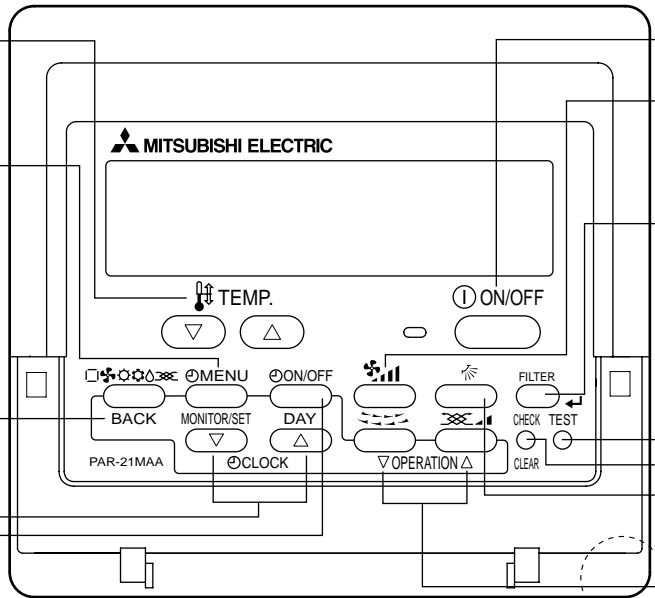
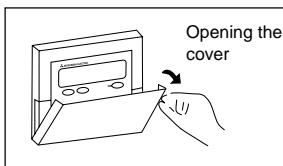

ON/OFF button

Fan Speed button

Filter button (<Enter> button)

Test Run button

Check button (Clear button)

Airflow Up/Down button

Louver button (▽ Operation button)  
▽ To return operation number

Ventilation button (△ Operation button)  
△ To go to next operation number

Built-in temperature sensor

#### Note:

- "PLEASE WAIT" message  
This message is displayed for approximately 3 minutes when power is supplied to the indoor unit or when the unit is recovering from a power failure.
- "NOT AVAILABLE" message  
This message is displayed if an invalid button is pressed (to operate a function that the indoor unit does not have).  
If a single remote controller is used to operate multiple indoor units simultaneously that are different types, this message will not be displayed as far as any of the indoor units is equipped with the function.

# 5

# SPECIFICATIONS

Service Ref.			PLA-RP35BA	PLA-RP35BA <sub>1</sub>	PLA-RP35BAR1	
INDOOR UNIT	Mode		Cooling		Heating	
	Power supply (phase, cycle, voltage)		Single phase, 50Hz, 230V			
	Input	kW	0.03		0.02	
			Running current	A	0.22	
	External finish (Panel)				Munsell 6.4Y 8.9/0.4	
	Heat exchanger		Plate fin coil			
	Fan	Fan (drive) × No.		Turbo fan (direct) × 1		
		Fan motor output		0.050		
		Airflow (Low-Medium2-Medium1-High)	m <sup>3</sup> /min(CFM)	11-12-13-15(390-425-460-530)		
		External static pressure		Pa(mmAq) 0(direct blow)		
	Booster heater		kW			-
	Operation control & Thermostat		Remote controller & built-in			
	Noise level (Low-Medium2-Medium1-High)		dB			27-28-29-31
	Field drain pipe O.D.		mm(in.)			32 (1-1/4)
	Dimensions	W	mm(in.)	UNIT : 840 (33-1/16)	PANEL : 950 (37-3/8)	
D		mm(in.)	UNIT : 840 (33-1/16)	PANEL : 950 (37-3/8)		
H		mm(in.)	UNIT : 258 (10-3/16)	PANEL : 35 (1-3/8)		
Weight		kg(lbs)	UNIT : 22 (49)	PANEL : 6 (13)		

Service Ref.			PLA-RP50BA	PLA-RP50BA <sub>1</sub>	PLA-RP50BAR1	
INDOOR UNIT	Mode		Cooling		Heating	
	Power supply (phase, cycle, voltage)		Single phase, 50Hz, 230V			
	Input	kW	0.05		0.04	
			Running current	A	0.36	
	External finish (Panel)				Munsell 6.4Y 8.9/0.4	
	Heat exchanger		Plate fin coil			
	Fan	Fan (drive) × No.		Turbo fan (direct) × 1		
		Fan motor output		0.050		
		Airflow (Low-Medium2-Medium1-High)	m <sup>3</sup> /min(CFM)	12-14-16-18(425-495-565-635)		
		External static pressure		Pa(mmAq) 0(direct blow)		
	Booster heater		kW			-
	Operation control & Thermostat		Remote controller & built-in			
	Noise level (Low-Medium2-Medium1-High)		dB			28-29-31-32
	Field drain pipe O.D.		mm(in.)			32(1-1/4)
	Dimensions	W	mm(in.)	UNIT : 840 (33-1/16)	PANEL : 950 (37-3/8)	
D		mm(in.)	UNIT : 840 (33-1/16)	PANEL : 950 (37-3/8)		
H		mm(in.)	UNIT : 258 (10-3/16)	PANEL : 35 (1-3/8)		
Weight		kg(lbs)	UNIT : 22 (49)	PANEL : 6 (13)		

Service Ref.			PLA-RP60BA	PLA-RP60BA <sub>1</sub>	PLA-RP60BAR1	
INDOOR UNIT	Mode		Cooling		Heating	
	Power supply (phase, cycle, voltage)		Single phase, 50Hz, 230V			
	Input	kW	0.05		0.04	
			Running current	A	0.36	
	External finish (Panel)				Munsell 6.4Y 8.9/0.4	
	Heat exchanger		Plate fin coil			
	Fan	Fan (drive) × No.		Turbo fan (direct) × 1		
		Fan motor output		0.050		
		Airflow (Low-Medium2-Medium1-High)	m <sup>3</sup> /min(CFM)	12-14-16-18(425-495-565-635)		
		External static pressure		Pa(mmAq) 0(direct blow)		
	Booster heater		kW			-
	Operation control & Thermostat		Remote controller & built-in			
	Noise level (Low-Medium2-Medium1-High)		dB			28-29-31-32
	Field drain pipe O.D.		mm(in.)			32(1-1/4)
	Dimensions	W	mm(in.)	UNIT : 840 (33-1/16)	PANEL : 950 (37-3/8)	
D		mm(in.)	UNIT : 840 (33-1/16)	PANEL : 950 (37-3/8)		
H		mm(in.)	UNIT : 258 (10-3/16)	PANEL : 35 (1-3/8)		
Weight		kg(lbs)	UNIT : 23 (51)	PANEL : 6 (13)		



Service Ref.			PLA-RP71BA PLA-RP71BA1 PLA-RP71BAR1		
INDOOR UNIT	Mode		Cooling	Heating	
	Power supply (phase, cycle, voltage)		Single phase, 50Hz, 230V		
	Input	kW	0.07	0.06	
	Running current	A	0.51	0.43	
	External finish (Panel)		Munsell 6.4Y 8.9/0.4		
	Heat exchanger		Plate fin coil		
	Fan	Fan (drive) × No.		Turbo fan (direct) × 1	
		Fan motor output	kW	0.050	
		Airflow (Low-Medium2-Medium1-High)	m³/min(CFM)	14-16-18-21(485-565-635-740)	
		External static pressure	Pa(mmAq)	0(direct blow)	
	Booster heater		kW	-	
	Operation control & Thermostat		Remote controller & built-in		
	Noise level (Low-Medium2-Medium1-High)		28-30-32-34		
	Field drain pipe O.D.		32(1-1/4)		
	Dimensions	W	mm(in.)	UNIT : 840 (33-1/16)	PANEL : 950 (37-3/8)
D		mm(in.)	UNIT : 840 (33-1/16)	PANEL : 950 (37-3/8)	
H		mm(in.)	UNIT : 258 (10-3/16)	PANEL : 35 (1-3/8)	
Weight		kg(lbs)	UNIT : 23 (51)	PANEL : 6 (13)	

Service Ref.			PLA-RP100BA		
INDOOR UNIT	Mode		Cooling	Heating	
	Power supply (phase, cycle, voltage)		Single phase, 50Hz, 230V		
	Input	kW	0.14	0.13	
	Running current	A	0.94	0.87	
	External finish (Panel)		Munsell 6.4Y 8.9/0.4		
	Heat exchanger		Plate fin coil		
	Fan	Fan (drive) × No.		Turbo fan (direct) × 1	
		Fan motor output	kW	0.120	
		Airflow (Low-Medium2-Medium1-High)	m³/min(CFM)	20-23-26-30(710-810-920-1,060)	
		External static pressure	Pa(mmAq)	0(direct blow)	
	Booster heater		kW	-	
	Operation control & Thermostat		Remote controller & built-in		
	Noise level (Low-Medium2-Medium1-High)		32-34-37-40		
	Field drain pipe O.D.		32(1-1/4)		
	Dimensions	W	mm(in.)	UNIT : 840 (33-1/16)	PANEL : 950 (37-3/8)
D		mm(in.)	UNIT : 840 (33-1/16)	PANEL : 950 (37-3/8)	
H		mm(in.)	UNIT : 298 (11-3/4)	PANEL : 35 (1-3/8)	
Weight		kg(lbs)	UNIT : 25 (55)	PANEL : 6 (13)	

Service Ref.			PLA-RP125BA		
INDOOR UNIT	Mode		Cooling	Heating	
	Power supply (phase, cycle, voltage)		Single phase, 50Hz, 230V		
	Input	kW	0.15	0.14	
	Running current	A	1.00	0.94	
	External finish (Panel)		Munsell 6.4Y 8.9/0.4		
	Heat exchanger		Plate fin coil		
	Fan	Fan (drive) × No.		Turbo fan (direct) × 1	
		Fan motor output	kW	0.120	
		Airflow (Low-Medium2-Medium1-High)	m³/min(CFM)	22-25-28-31(780-880-990-1,090)	
		External static pressure	Pa(mmAq)	0(direct blow)	
	Booster heater		kW	-	
	Operation control & Thermostat		Remote controller & built-in		
	Noise level (Low-Medium2-Medium1-High)		34-36-39-41		
	Field drain pipe O.D.		32(1-1/4)		
	Dimensions	W	mm(in.)	UNIT : 840 (33-1/16)	PANEL : 950 (37-3/8)
D		mm(in.)	UNIT : 840 (33-1/16)	PANEL : 950 (37-3/8)	
H		mm(in.)	UNIT : 298 (11-3/4)	PANEL : 35 (1-3/8)	
Weight		kg(lbs)	UNIT : 25 (55)	PANEL : 6 (13)	



Service Ref.			PLA-RP140BA	
Mode			Cooling	Heating
Power supply (phase, cycle, voltage)			Single phase, 50Hz, 230V	
Input		kW	0.16	0.15
Running current		A	1.07	1.00
External finish (Panel)			Munsell 6.4Y 8.9/0.4	
Heat exchanger			Plate fin coil	
Fan			Turbo fan (direct) × 1	
Fan(drive) × No.				
Fan motor output		kW	0.120	
Airflow (Low-Medium2-Medium1-High)		m <sup>3</sup> /min(CFM)	24-26-29-32(850-920-1,020-1,130)	
External static pressure		Pa(mmAq)	0(direct blow)	
Booster heater			kW	
Operation control & Thermostat			Remote controller & built-in	
Noise level (Low-Medium2-Medium1-High)		dB	36-39-42-44	
Field drain pipe O.D.			mm(in.)	
			32(1-1/4)	
Dimensions		W	UNIT : 840 (33-1/16) PANEL : 950 (37-3/8)	
		D	UNIT : 840 (33-1/16) PANEL : 950 (37-3/8)	
		H	UNIT : 298 (11-3/4) PANEL : 35 (1-3/8)	
Weight		kg(lbs)	UNIT : 27 (60) PANEL : 6 (13)	

INDOOR UNIT

# 6

# NOISE CRITERION CURVES

**PLA-RP35BA**  
**PLA-RP35BA<sub>1</sub>**  
**PLA-RP35BAR1**

NOTCH	SPL(dB)	LINE
High	31	○—○
Medium1	29	●—●
Medium2	28	△—△
Low	27	▲—▲

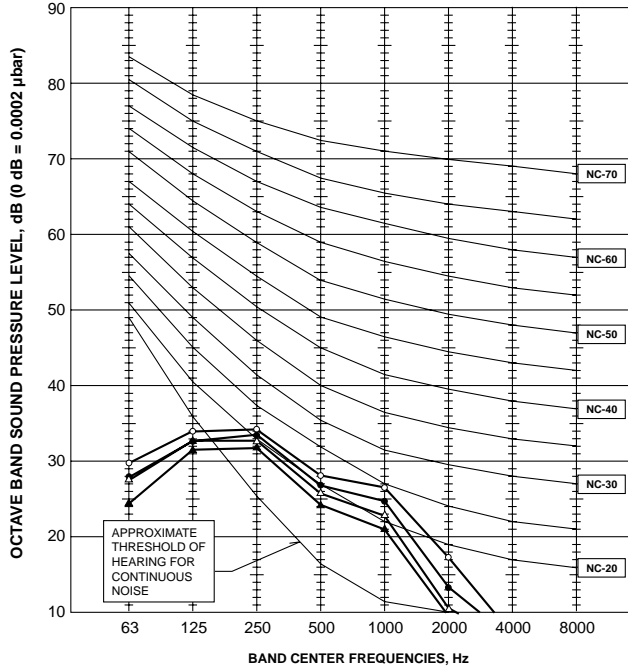

**PLA-RP50BA**  
**PLA-RP50BA<sub>1</sub>**  
**PLA-RP50BAR1**

NOTCH	SPL(dB)	LINE
High	32	○—○
Medium1	31	●—●
Medium2	29	△—△
Low	28	▲—▲

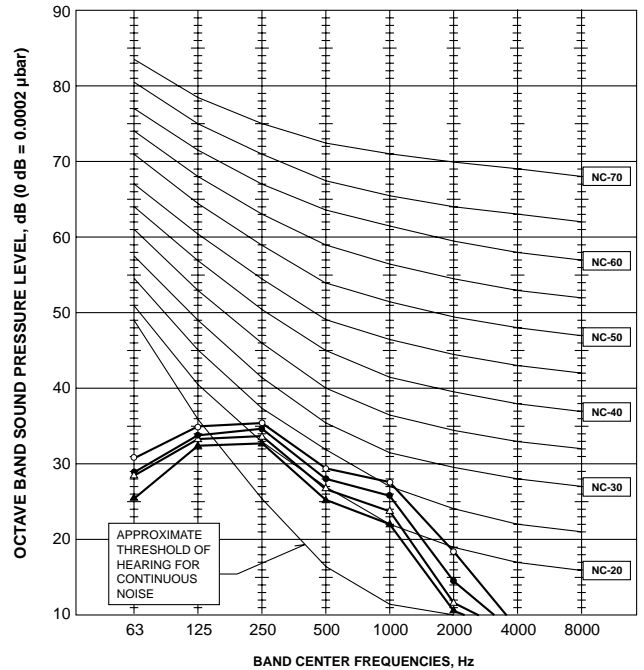

**PLA-RP60BA**  
**PLA-RP60BA<sub>1</sub>**  
**PLA-RP60BAR1**

NOTCH	SPL(dB)	LINE
High	32	○—○
Medium1	31	●—●
Medium2	29	△—△
Low	28	▲—▲

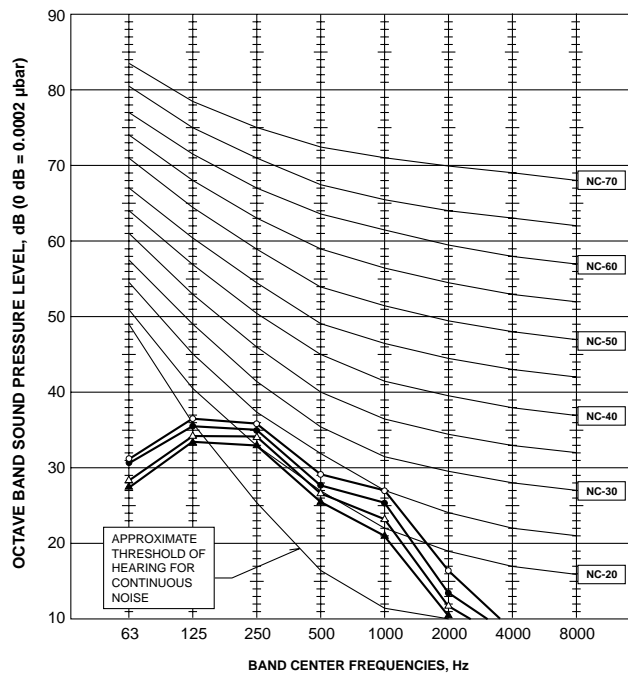

**PLA-RP71BA**  
**PLA-RP71BA<sub>1</sub>**  
**PLA-RP71BAR1**

NOTCH	SPL(dB)	LINE
High	34	○—○
Medium1	32	●—●
Medium2	30	△—△
Low	28	▲—▲

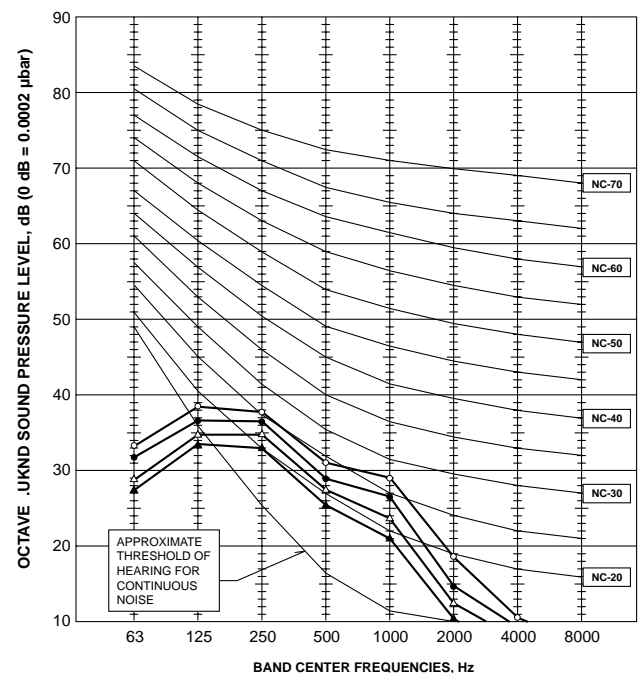

### PLA-RP100BA

NOTCH	SPL(dB)	LINE
High	40	○—○
Medium1	37	●—●
Medium2	34	△—△
Low	32	▲—▲

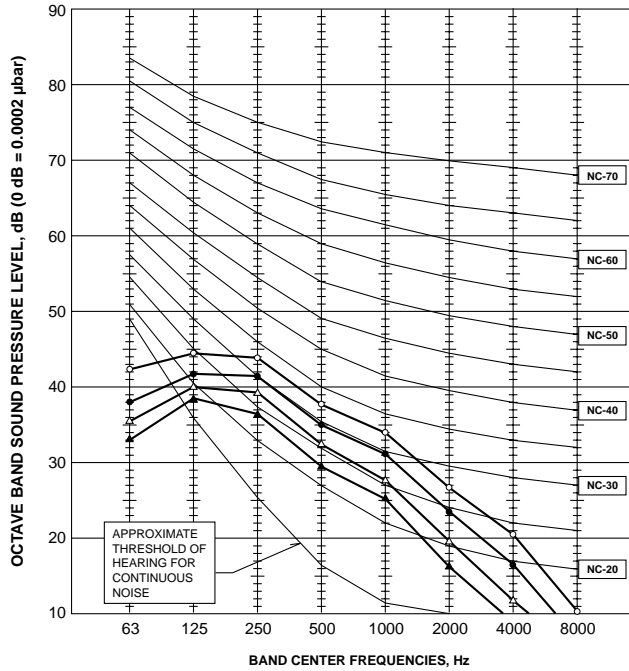

### PLA-RP125BA

NOTCH	SPL(dB)	LINE
High	41	○—○
Medium1	39	●—●
Medium2	36	△—△
Low	34	▲—▲

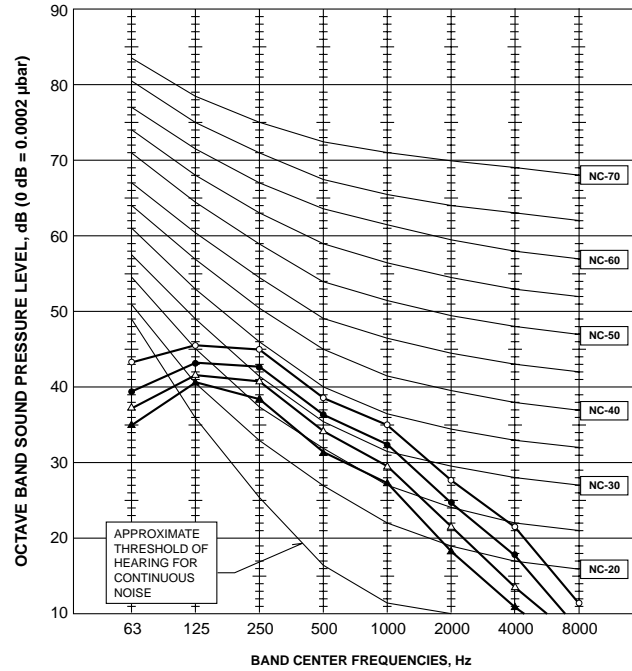

### PLA-RP140BA

NOTCH	SPL(dB)	LINE
High	44	○—○
Medium1	42	●—●
Medium2	39	△—△
Low	36	▲—▲

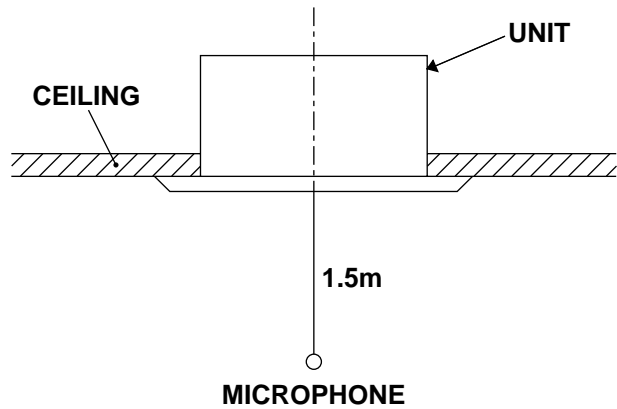
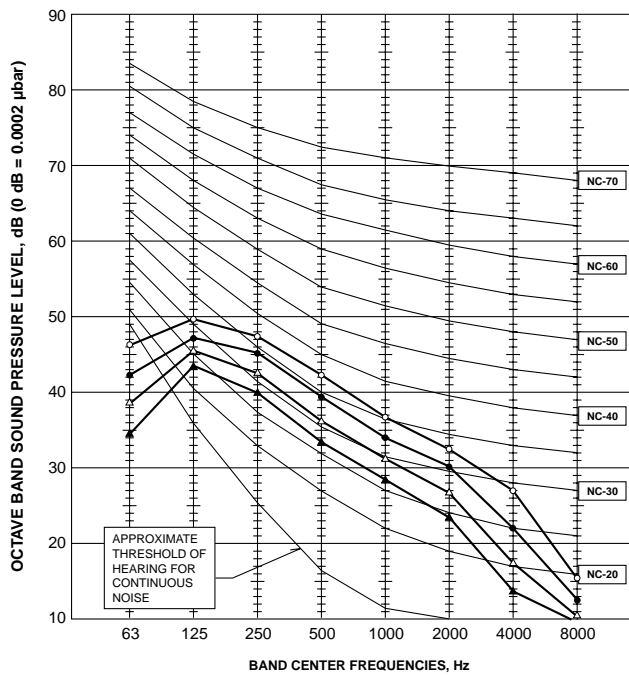



PLA-RP35BA  
PLA-RP100BA  
PLA-RP35BA<sub>1</sub>  
PLA-RP35BAR<sub>1</sub>

PLA-RP50BA  
PLA-RP125BA  
PLA-RP50BA<sub>1</sub>  
PLA-RP50BAR<sub>1</sub>

PLA-RP60BA  
PLA-RP140BA  
PLA-RP60BA<sub>1</sub>  
PLA-RP60BAR<sub>1</sub>

PLA-RP71BA  
PLA-RP71BA<sub>1</sub>  
PLA-RP71BAR<sub>1</sub>

Unit : mm

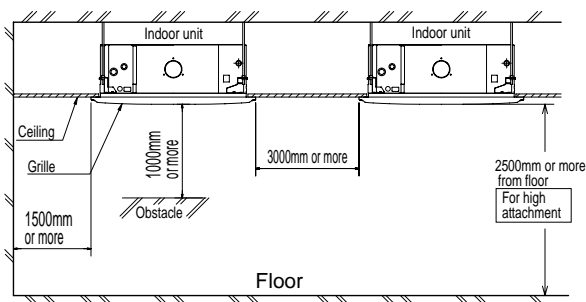
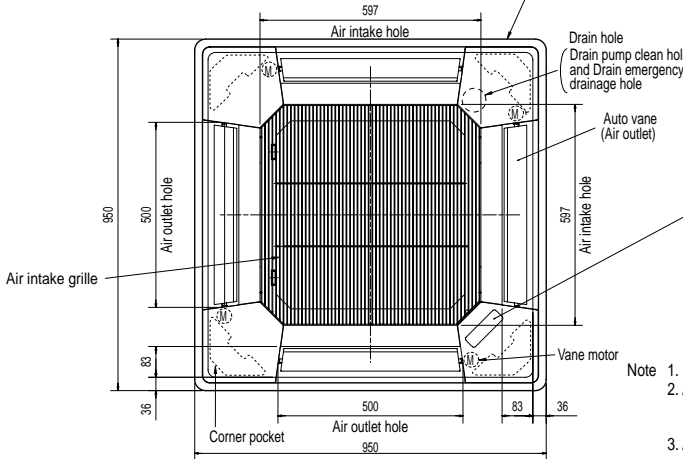
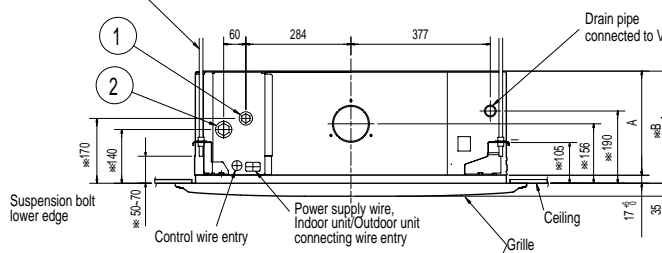
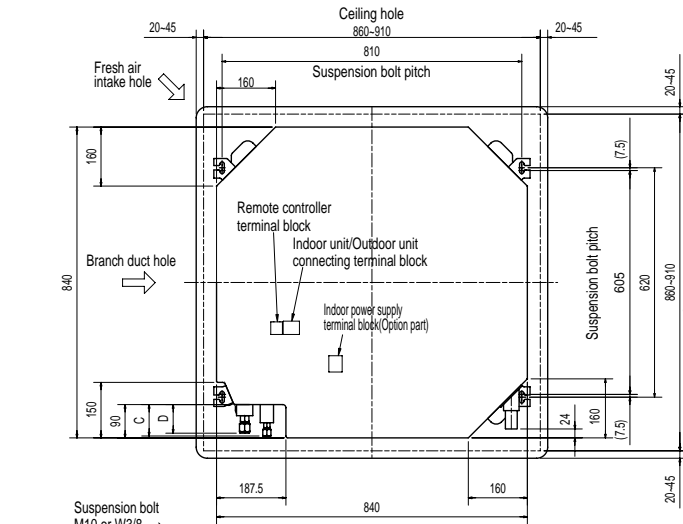

Detail connecting of branch duct(Both aspects)

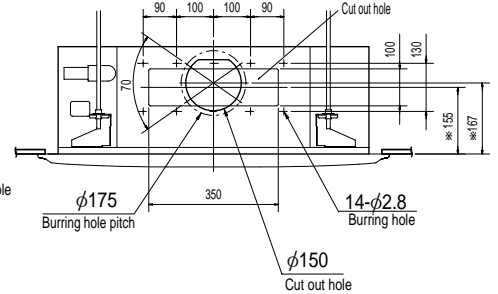

Detail drawing of fresh air intake hole

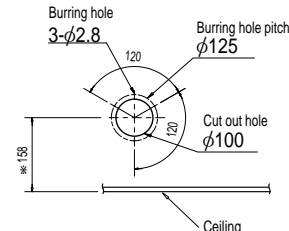

In case of standard grille : PLP-6BA / PLP-6BAMD



In case of auto-grille : PLP-6BAJ

In case of wireless remote controller : PLP-6BALM

Emergency operation switch<Cooling>and Emergency Up/Down switch<Up>  
Emergency operation switch<Heating>and Emergency Up/Down switch<Down>

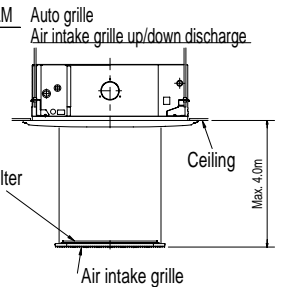
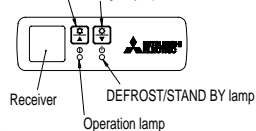

- Note
1. Please choose the grille between a standard grille and an auto-grille.
  2. As for drain pipe, please use VP-25(O.D. φ32 PVC TUBE). Drain pump is included. Max. lifting height is 850mm from the ceiling.
  3. As for suspension bolt, please use M10 or W3/8. (Procured at local site)
  4. Electrical box may be removed for the service purpose. Make sure to slack the electrical wire a bit for control/ power wires connection.
  5. The height of the indoor unit is able to be adjusted with the grille attached.
  6. For the installation of the optional high efficiency filter or optional multi-functional casement.
    - 1) Requires E or more space between transom and ceiling for the installation.
    - 2) Add 135 mm to the dimensions \* marked on the figure.
    - 3) The optional high efficiency filter must be used jointly with the optional multi-functional casement.
  7. When installing the branch ducts, be sure to insulate adequately. Otherwise condensation and dripping may occur. (It becomes the cause of dew drops/water dew.)
  8. As for necessary installation/service space, please refer to the left figure.

Models	Unit : mm							
	①	②	A	B	C	D	E	
PLA-RP35/50BA	Refrigerant pipe ---φ6.35 Flared connection ---1/4 F	Refrigerant pipe ---φ12.7 Flared connection ---1/2 F	241	258	87	80	74	400
PLA-RP60BA	Refrigerant pipe φ6.35 / φ9.52 Flared connection 1/4 F / 3/8 F (compatible)	Refrigerant pipe ---φ15.88 Flared connection ---5/8 F						
PLA-RP71BA	Refrigerant pipe ---φ9.52 Flared connection ---3/8 F		281	298	85	77	440	

PLA-RP35BA  
PLA-RP100BA  
PLA-RP35BA<sub>1</sub>  
PLA-RP35BAR1

PLA-RP50BA  
PLA-RP125BA  
PLA-RP50BA<sub>1</sub>  
PLA-RP50BAR1

PLA-RP60BA  
PLA-RP140BA  
PLA-RP60BA<sub>1</sub>  
PLA-RP60BAR1

PLA-RP71BA  
PLA-RP71BA<sub>1</sub>  
PLA-RP71BAR1

[LEGEND]

SYMBOL	NAME	SYMBOL	NAME	SYMBOL	NAME
I.B	INDOOR CONTROLLER BOARD	DCL	REACTOR	OPTION PART	
CN2L	CONNECTOR (LOSSNAY)	DP	DRAIN PUMP	W.B	PCB FOR WIRELESS REMOTE CONTROLLER
CN32	CONNECTOR (REMOTE SWITCH)	FS	DRAIN FLOAT SWITCH	BZ	BUZZER
CN41	CONNECTOR (HA TERMINAL-A)	MF	FAN MOTOR	LED1	LED (OPERATION INDICATION : GREEN)
CN51	CONNECTOR (CENTRALLY CONTROL)	MV	VANE MOTOR	LED2	LED (PREPARATION FOR HEATING : ORANGE)
FUSE	FUSE (T6.3AL250V)	TB2	TERMINAL BLOCK (Indoor unit Power (option))	RU	RECEIVING UNIT
LED1	POWER SUPPLY (I.B)	TB4	TERMINAL BLOCK (INDOOR/OUTDOOR CONNECTING LINE)	SW1	EMERGENCY OPERATION (HEAT / DOWN)
LED2	POWER SUPPLY (R.B)	TB5, TB6	TERMINAL BLOCK (REMOTE CONTROLLER TRANSMISSION LINE)	SW2	EMERGENCY OPERATION (COOL / UP)
LED3	TRANSMISSION (INDOOR-OUTDOOR)	TH1	ROOM TEMP. THERMISTOR (0°C / 15kΩ, 25°C / 5. 4kΩ DETECT)		
SW1	SWITCH (MODEL SELECTION) *See table 1	TH2	PIPE TEMP. THERMISTOR/LIQUID (0°C / 15kΩ, 25°C / 5. 4kΩ DETECT)		
SW2	SWITCH (CAPACITY CODE) *See table 2	TH5	COND. / EVA. TEMP. THERMISTOR (0°C / 15kΩ, 25°C / 5. 4kΩ DETECT)		
SWE	CONNECTOR (EMERGENCY OPERATION)				
X1	RELAY (DRAIN PUMP)				

Please set the voltage using the remote controller. For the setting method, please refer to the indoor unit Installation Manual.

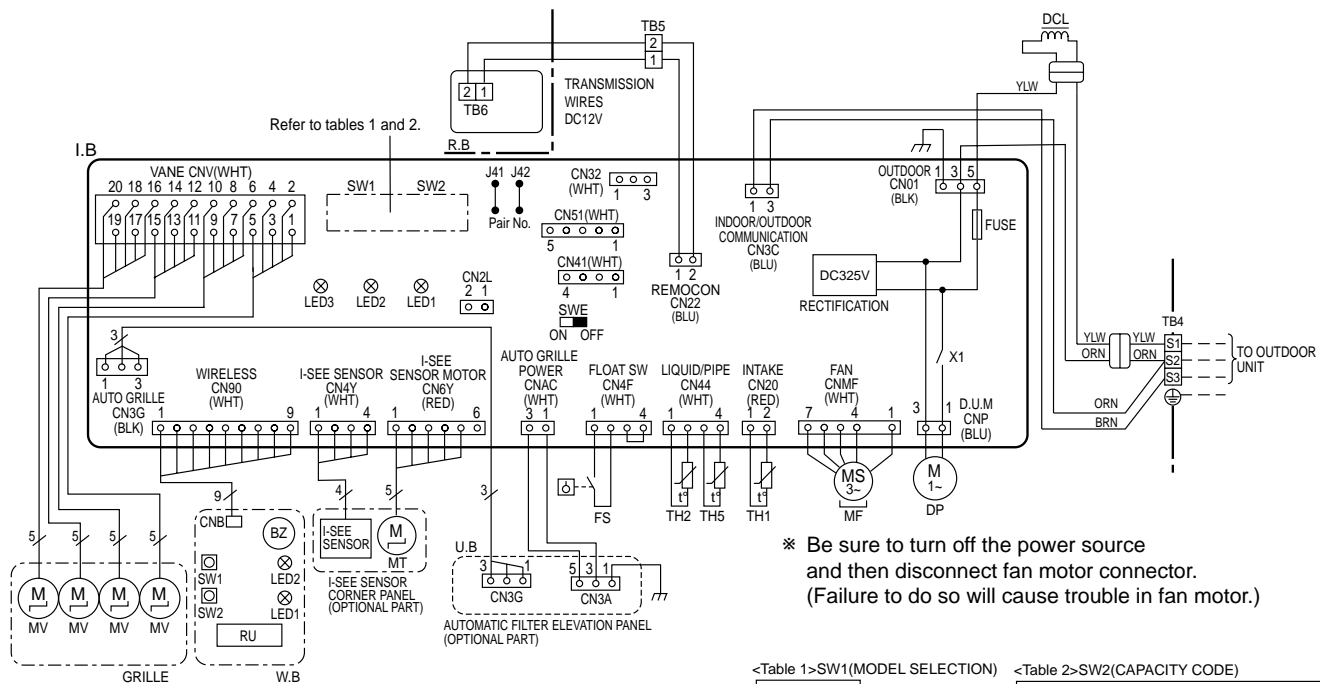

\* Be sure to turn off the power source and then disconnect fan motor connector. (Failure to do so will cause trouble in fan motor.)

<Table 1>SW1(MODEL SELECTION)

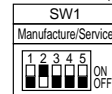

<Table 2>SW2(CAPACITY CODE)

MODELS	Manufacture/Service	MODELS	Manufacture/Service
PLA-RP35BA	1 2 3 4 5 ON OFF	PLA-RP100BA	1 2 3 4 5 ON OFF
PLA-RP50BA	1 2 3 4 5 ON OFF	PLA-RP125BA	1 2 3 4 5 ON OFF
PLA-RP60BA	1 2 3 4 5 ON OFF	PLA-RP140BA	1 2 3 4 5 ON OFF
PLA-RP71BA	1 2 3 4 5 ON OFF		

The black square (■) indicates a switch position.

Notes:

- Symbols used in wiring diagram above are, □: Connector, ○: Terminal (block).
- Indoor and outdoor connecting wires have polarities, make sure to match terminal numbers (S1, S2, S3) for correct wirings.
- Since the outdoor side electric wiring may change, be sure to check the outdoor unit electric wiring for servicing.
- This diagram shows the wiring of Indoor and Outdoor connecting wires (specification of 230V), adopting superimposed system of power and signal.
  - \*1: When work to Supply power separately to indoor and outdoor units was applied, refer to Fig 1.
  - \*2: For power supply system of this unit, refer to the caution label located near this diagram.

[Self-diagnosis]

- For details on how to operate self-diagnosis with the wireless remote control, refer to the technical manuals etc.
- For the wired remote control: when you quickly press twice the CHECK switch on the remote control, the unit begins self-diagnosis, and Check Codes generated in the past appear on the display.

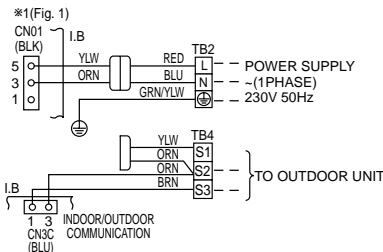

9

**REFRIGERANT SYSTEM DIAGRAM**

PLA-RP35BA  
 PLA-RP100BA  
 PLA-RP35BA<sub>1</sub>  
 PLA-RP35BAR1

PLA-RP50BA  
 PLA-RP125BA  
 PLA-RP50BA<sub>1</sub>  
 PLA-RP50BAR1

PLA-RP60BA  
 PLA-RP140BA  
 PLA-RP60BA<sub>1</sub>  
 PLA-RP60BAR1

PLA-RP71BA  
 PLA-RP71BA<sub>1</sub>  
 PLA-RP71BAR1

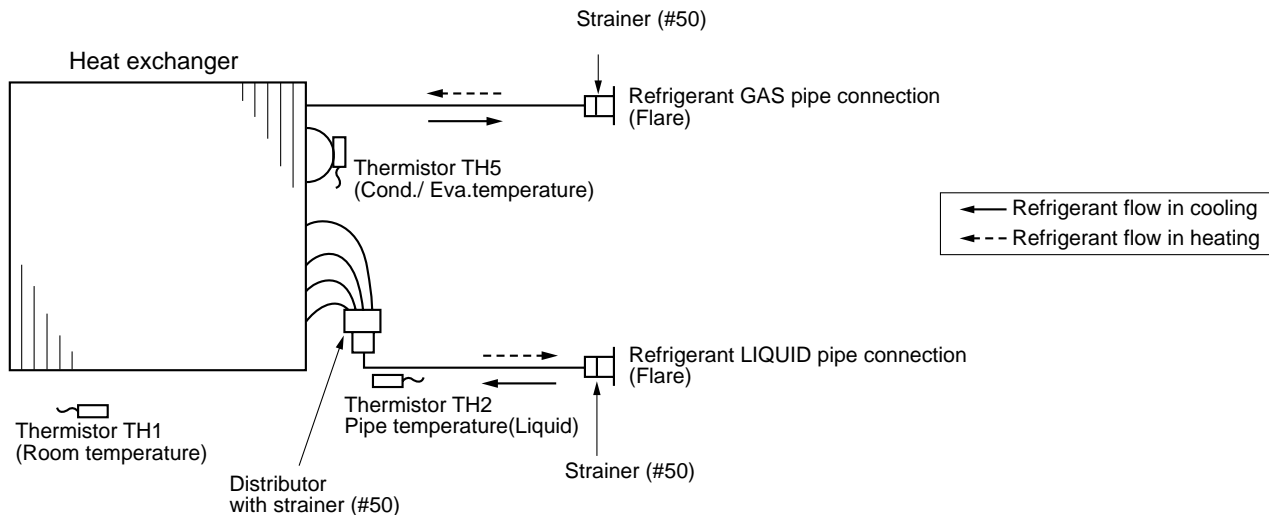

## 10-1. TROUBLESHOOTING

## &lt;Error code display by self-diagnosis and actions to be taken for service (summary)&gt;

Present and past error codes are logged and displayed on the wired remote controller or controller board of outdoor unit. Actions to be taken for service and the trouble reoccurrence at field are summarized in the table below. Check the contents below before investigating details.

Unit conditions at service	Error code	Actions to be taken for service (summary)
The trouble is reoccurring.	Displayed	Judge what is wrong and take a corrective action according to "SELF-DIAGNOSIS ACTION TABLE" (10-3).
	Not displayed	Identify the cause of the trouble and take a corrective action according to "TROUBLESHOOTING OF PROBLEMS" (10-4).
The trouble is not reoccurring.	Logged	<ul style="list-style-type: none"> <li>①Consider the temporary defects such as the work of protection devices in the refrigerant circuit including compressor, poor connection of wiring, noise and etc. Re-check the symptom, and check the installation environment, refrigerant amount, weather when the trouble occurred, and wiring related.</li> <li>②Reset error code logs and restart the unit after finishing service.</li> <li>③There is no abnormality in electrical components, controller boards, and remote controller.</li> </ul>
	Not logged	<ul style="list-style-type: none"> <li>①Recheck the abnormal symptom.</li> <li>②Identify the cause of the trouble and take a corrective action according to "TROUBLESHOOTING OF PROBLEMS" (10-4).</li> <li>③Continue to operate unit for the time being if the cause is not ascertained.</li> <li>④There is no abnormality in electrical components, controller boards, remote controller etc.</li> </ul>

## 10-2. MALFUNCTION-DIAGNOSIS METHOD BY REMOTE CONTROLLER

### <In case of trouble during operation>

When a malfunction occurs to air conditioner, both indoor unit and outdoor unit will stop and operation lamp blinks to inform unusual stop.

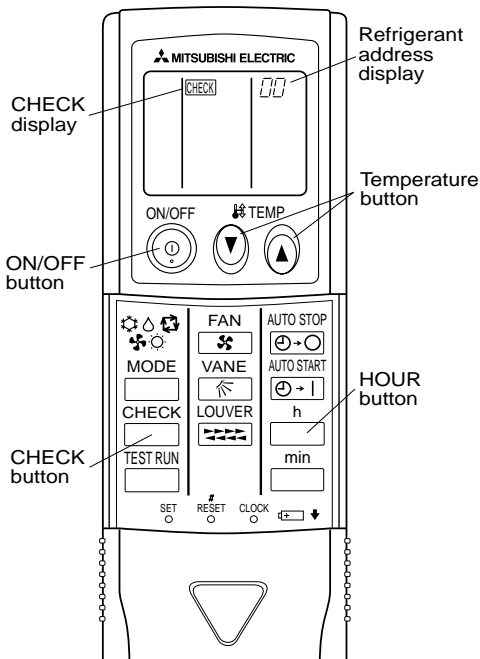

### <Malfunction-diagnosis method at maintenance service>



#### [Procedure]

1. Press the CHECK button twice.

- "CHECK" lights, and refrigerant address "00" flashes.
- Check that the remote controller's display has stopped before continuing.

2. Press the temperature   buttons.

- Select the refrigerant address of the indoor unit for the self-diagnosis.
- Note: Set refrigerant address using the outdoor unit's DIP switch (SW1). (For more information, see the outdoor unit installation manual.)

3. Point the remote controller at the sensor on the indoor unit and press the HOUR button.

- If an air conditioner error occurs, the indoor unit's sensor emits an intermittent buzzer sound, the operation light flashes, and the error code is output. (It takes 3 seconds at most for error code to appear.)

4. Point the remote controller at the sensor on the indoor unit and press the ON/OFF button.

- The check mode is cancelled.

To be continued to the next page.

• Refer to the following tables for details on the check codes.

[Output pattern A]

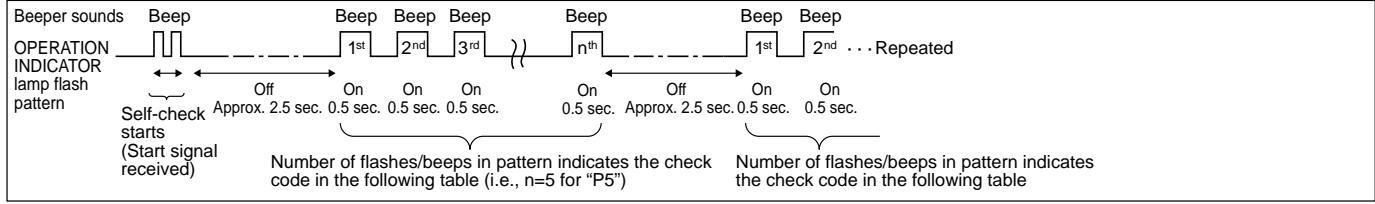

[Output pattern B]

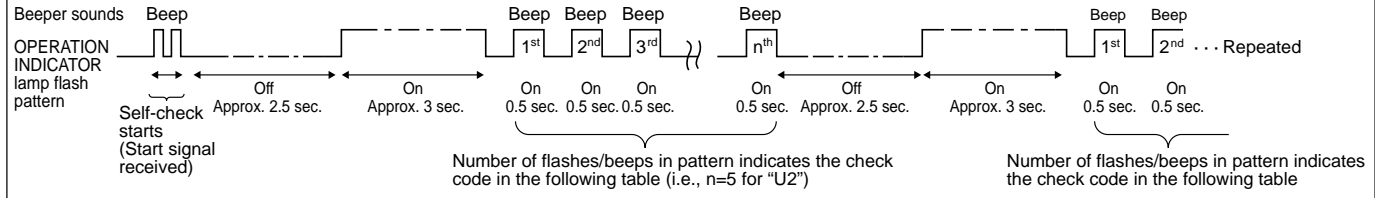

[Output pattern A] Errors detected by indoor unit

Wireless remote controller	Wired remote controller	Symptom	Remark
Beeper sounds/OPERATION INDICATOR lamp flashes (Number of times)	① Check code		
1	P1	Intake sensor error	—
2	P2	Pipe (TH2) sensor error	
	P9	Pipe (TH5) sensor error	
3	E6,E7	Indoor/outdoor unit communication error	
4	P4	Float switch connector open	
5	P5	Drain pump error(due to water leakage abnormality)	
	PA	Forced compressor stop	
6	P6	Freezing/Overheating protection operation	
7	EE	Communication error between indoor and outdoor units	
8	P8	Pipe temperature error	
9	E4, E5	Remote controller signal receiving error	
10	-	-	
11	-	-	
12	Fb (FB) *3	Indoor unit control system error (memory error, etc.)	
	PL	Refrigerant circuit abnormal	
-	E0, E3	Remote controller transmission error	
-	E1, E2	Remote controller control board error	

[Output pattern B] Errors detected by unit other than indoor unit (outdoor unit, etc.)

Wireless remote controller	Wired remote controller	Symptom	Remark
Beeper sounds/OPERATION INDICATOR lamp flashes (Number of times)	① Check code		
1	E9	Indoor/outdoor unit communication error (Transmitting error) (Outdoor unit)	For details, check the LED display of the outdoor controller board. As for outdoor unit, refer to outdoor unit's service manual.
2	UP	Compressor overcurrent interruption	
3	U3,U4	Open/short of outdoor unit thermistors	
4	UF	Compressor overcurrent interruption (When compressor locked)	
5	U2	Abnormal high discharging temperature/49C operated/insufficient refrigerant	
6	U1,Ud (UD) *3	Abnormal high pressure (63H operated)/Overheating protection operation	
7	U5	Abnormal temperature of heat sink	
8	U8	Outdoor unit fan protection stop	
9	U6	Compressor overcurrent interruption/Abnormal of power module	
10	U7	Abnormality of superheat due to low discharge temperature	
11	U9,UH	Abnormality such as overvoltage or voltage shortage and abnormal synchronous signal to main circuit/Current sensor error	
12	-	-	
13	-	-	
14	Others	Other errors (Refer to the technical manual for the outdoor unit.)	

\*1 If the beeper does not sound again after the initial 2 beeps to confirm the self-check start signal was received and the OPERATION INDICATOR lamp does not come on, there are no error records.

\*2 If the beeper sounds 3 times continuously "beep, beep, beep (0.4 + 0.4 + 0.4 sec.)" after the initial 2 beeps to confirm the self-check start signal was received, the specified refrigerant address is incorrect.

\*3 The check code in the parenthesis indicates PAR-30MAA model.

- On wireless remote controller  
The continuous buzzer sounds from receiving section of indoor unit.  
Blink of operation lamp
  - On wired remote controller
- ① Check code displayed in the LCD.

• If the unit cannot be operated properly after the test run, refer to the following table to find out the cause.

Symptom		Cause
Wired remote controller	LED 1, 2 (PCB in outdoor unit)	
PLEASE WAIT	For about 2 minutes after power-on	After LED 1, 2 are lighted, LED 2 is turned off, then only LED 1 is lighted. (Correct operation)
PLEASE WAIT → Error code	Subsequent to about 2 minutes after power-on	Only LED 1 is lighted. → LED 1, 2 blink.
Display messages do not appear even when operation switch is turned ON (operation lamp does not light up).		Only LED 1 is lighted. → LED 1 blinks twice, LED 2 blinks once.

On the wireless remote controller with condition above, following phenomena take place.

- No signals from the remote controller can be received.
- OPE lamp is blinking.
- The buzzer makes a short ping sound.

**Note:**

**Operation is not possible for about 30 seconds after cancellation of function selection. (Correct operation)**

For description of each LED (LED1, 2, 3) provided on the indoor controller, refer to the following table.

LED1 (power for microprocessor)	Indicates whether control power is supplied. Make sure that this LED is always lit.
LED2 (power for remote controller)	Indicates whether power is supplied to the remote controller. This LED lights only in the case of the indoor unit which is connected to the outdoor unit refrigerant addresses "0".
LED3 (communication between indoor and outdoor units)	Indicates state of communication between the indoor and outdoor units. Make sure that this LED is always blinking.

Note: Refer to the manual of outdoor unit for the details of display such as F, U, and other E.

### 10-3. SELF-DIAGNOSIS ACTION TABLE

Error Code	Abnormal point and detection method	Cause	Countermeasure
P1	<p><b>Room temperature thermistor (TH1)</b></p> <p>① The unit is in 3-minute resume prevention mode if short/open of thermistor is detected. Abnormal if the unit does not reset normally after 3 minutes. (The unit returns to normal operation, if it has been reset normally.)</p> <p>② Constantly detected during cooling, drying, and heating operation. Short: -90°C or more Open: -40°C or less</p>	<p>① Defective thermistor characteristics</p> <p>② Contact failure of connector (CN20) on the indoor controller board (Insert failure)</p> <p>③ Breaking of wire or contact failure of thermistor wiring</p> <p>④ Defective indoor controller board</p>	<p>①-③ Check resistance value of thermistor. 0°C .....15.0kΩ 10°C .....9.6kΩ 20°C .....6.3kΩ 30°C .....4.3kΩ 40°C .....3.0kΩ</p> <p>If you put force on (draw or bend) the lead wire while measuring resistance value of thermistor, breaking of wire or contact failure can be detected.</p> <p>② Check contact failure of connector (CN20) on the indoor controller board. Refer to 10-7. Turn the power on again and check restart after inserting connector again.</p> <p>④ Check room temperature display on remote controller. Replace indoor controller board if there is abnormal difference with actual room temperature.</p> <p>Turn the power off, and on again to operate after check.</p>
P2	<p><b>Pipe temperature thermistor/Liquid (TH2)</b></p> <p>① The unit is in 3-minute resume prevention mode if short/open of thermistor is detected. Abnormal if the unit does not reset normally after 3 minutes. (The unit returns to normal operation, if it has been reset normally.)</p> <p>② Constantly detected during cooling, drying, and heating (except defrosting) operation. Short: 90°C or more Open: -40°C or less</p>	<p>① Defective thermistor characteristics</p> <p>② Contact failure of connector (CN44) on the indoor controller board (Insert failure)</p> <p>③ Breaking of wire or contact failure of thermistor wiring</p> <p>④ Defective refrigerant circuit is causing thermistor temperature of 90°C or more or -40°C or less.</p> <p>⑤ Defective indoor controller board</p>	<p>①-③ Check resistance value of thermistor. For characteristics, refer to (P1) above.</p> <p>② Check contact failure of connector (CN44) on the indoor controller board. Refer to 10-7. Turn the power on and check restart after inserting connector again.</p> <p>④ Check pipe &lt;liquid&gt; temperature with remote controller in test run mode. If pipe &lt;liquid&gt; temperature is extremely low (in cooling mode) or high (in heating mode), refrigerant circuit may have defective.</p> <p>⑤ Check pipe &lt;liquid&gt; temperature with remote controller in test run mode. If there is extremely difference with actual pipe &lt;liquid&gt; temperature, replace indoor controller board.</p> <p>Turn the power off, and on again to operate after check.</p>
P4 (5701)	<p><b>Contact failure of drain float switch (CN4F)</b></p> <p>① Extract when the connector of drain float switch is disconnected. (③ and ④ of connector CN4F is not short-circuited.)</p> <p>② Constantly detected during operation.</p>	<p>① Contact failure of connector (Insert failure)</p> <p>② Defective indoor controller board</p>	<p>① Check contact failure of float switch connector. Turn the power on again and check after inserting connector again.</p> <p>② Operate with connector (CN4F) short-circuited. Replace indoor controller board if abnormality reappears.</p>
P5	<p><b>Drain overflow protection operation</b></p> <p>① Suspensive abnormality, if drain float switch is detected to be underwater for 1 minute and 30 seconds continuously with drain pump on. Turn off compressor and indoor fan.</p> <p>② Drain pump is abnormal if the condition above is detected during suspensive abnormality.</p> <p>③ Constantly detected during drain pump operation.</p>	<p>① Malfunction of drain pump</p> <p>② Defective drain Clogged drain pump Clogged drain pipe</p> <p>③ Defective drain float switch Jamming of drain float switch or malfunction of moving parts causing drain float switch to be detected under water (Switch On)</p> <p>④ Defective indoor-controller board</p>	<p>① Check if drain pump operates.</p> <p>② Check drain function.</p> <p>③ Remove drain float switch connector CN4F and check if it is short (Switch On) with the moving part of float switch UP, or OPEN with the moving part of float switch down. Replace float switch if it is short with the moving part of float switch down.</p> <p>④ Replace indoor controller board if it is short-circuited between ③-④ of the drain float switch connector CN4F and abnormality reappears.</p> <p>It is not abnormal if there is no problem about the above-mentioned ①-④ Turn the power off, and on again to operate after check.</p>





Error Code	Abnormal point and detection method	Cause	Countermeasure
P6	<p><b>Freezing/overheating protection is operating</b></p> <p>① Freezing protection (Cooling mode) The unit is in 6-minute resume prevention mode if pipe &lt;liquid or condenser/evaporator&gt; temperature stays under -15°C for 3 minutes, 3 minutes after the compressor started. Abnormal if it stays under -15°C for 3 minutes again within 16 minutes after 6-minute resume prevention mode.</p> <p>② Overheating protection (Heating mode) The units is in 6-minute resume prevention mode if pipe &lt;condenser/ evaporator&gt; temperature is detected as over 70°C after the compressor started. Abnormal if the temperature of over 70°C is detected again within 10 minutes after 6 minute resume prevention mode.</p>	<p>(Cooling or drying mode)</p> <p>① Clogged filter (reduced airflow) ② Short cycle of air path ③ Low load (low temperature) operation out of the tolerance range ④ Defective indoor fan motor • Fan motor is defective. • Indoor controller board is defective.</p> <p>⑤ Defective outdoor fan control ⑥ Overcharge of refrigerant ⑦ Defective refrigerant circuit (clogs)</p> <p>(Heating mode)</p> <p>① Clogged filter (reduced airflow) ② Short cycle of air path ③ Overload (high temperature) operation out of the tolerance range ④ Defective indoor fan motor • Fan motor is defective. • Indoor controller board is defective. ⑤ Defective outdoor fan control ⑥ Overcharge of refrigerant ⑦ Defective refrigerant circuit (clogs) ⑧ Bypass circuit of outdoor unit is defective.</p>	<p>(Cooling or drying mode)</p> <p>① Check clogs of the filter. ② Remove blockage.</p> <p>④ Refer to 10-6.</p> <p>⑤ Check outdoor fan motor. ⑥⑦ Check operating condition of refrigerant circuit.</p> <p>(Heating mode)</p> <p>① Check clogs of the filter. ② Remove blockage.</p> <p>④ Refer to 10-6.</p> <p>⑤ Check outdoor fan motor. ⑥-⑧ Check operating condition of refrigerant circuit.</p>
P8	<p><b>Pipe temperature</b> &lt;Cooling mode&gt; Detected as abnormal when the pipe temperature is not in the cooling range 3 minutes after compressor start and 6 minutes after the liquid or condenser/ evaporator pipe is out of cooling range. Note 1) It takes at least 9 minutes to detect. Note 2) Abnormality P8 is not detected in drying mode. Cooling range : -3 deg ≥ (TH-TH1) TH: Lower temperature between: liquid pipe temperature (TH2) and condenser/ evaporator temperature (TH5) TH1: Intake temperature</p> <p>&lt;Heating mode&gt; When 10 seconds have passed after the compressor starts operation and the hot adjustment mode has finished, the unit is detected as abnormal when condenser/ evaporator pipe temperature is not in heating range within 20 minutes.</p> <p>Note 3) It takes at least 27 minutes to detect abnormality. Note 4) It excludes the period of defrosting (Detection restarts when defrosting mode is over) Heating range : 3 deg ≤ (TH5-TH1)</p>	<p>① Slight temperature difference between indoor room temperature and pipe &lt;liquid or condenser/evaporator&gt; temperature thermistor • Shortage of refrigerant • Disconnected holder of pipe &lt;liquid or condenser/ evaporator&gt; thermistor • Defective refrigerant circuit</p> <p>② Converse connection of extension pipe (on plural units connection) ③ Converse wiring of indoor/ outdoor unit connecting wire (on plural units connection) ④ Defective detection of indoor room temperature and pipe &lt;condenser/evaporator&gt; temperature thermistor ⑤ Stop valve is not opened completely.</p>	<p>①~④ Check pipe &lt;liquid or condenser/ evaporator&gt; temperature with room temperature display on remote controller and outdoor controller circuit board. Pipe &lt;liquid or condenser/evaporator&gt; temperature display is indicated by setting SW2 of outdoor controller circuit board as follows.</p> <p>( Conduct temperature check with outdoor controller circuit board after connecting 'A-Control Service Tool(PAC-SK52ST)' )</p> <p>②③ Check converse connection of extension pipe or converse wiring of indoor/outdoor unit connecting wire.</p>

Error Code	Abnormal point and detection method	Cause	Countermeasure
P9	<p><b>Pipe temperature thermistor/ Condenser-Evaporator (TH5)</b></p> <p>① The unit is in 3-minute resume protection mode if short/open of thermistor is detected. Abnormal if the unit does not get back to normal within 3 minutes. (The unit returns to normal operation, if it has normally reset.)</p> <p>② Constantly detected during cooling, drying, and heating operation (except defrosting) Short: 90°C or more Open: -40°C or less</p>	<p>① Defective thermistor characteristics</p> <p>② Contact failure of connector (CN44) on the indoor controller board (Insert failure)</p> <p>③ Breaking of wire or contact failure of thermistor wiring</p> <p>④ Temperature of thermistor is 90°C or more or -40°C or less caused by defective refrigerant circuit.</p> <p>⑤ Defective indoor controller board</p>	<p>①-③ Check resistance value of thermistor. For characteristics, refer to (P1) above.</p> <p>② Check contact failure of connector (CN44) on the indoor controller board. Refer to 10-7. Turn the power on and check restart after inserting connector again.</p> <p>④ Operate in test run mode and check pipe &lt;condenser/evaporator&gt; temperature with outdoor controller circuit board. If pipe &lt;condenser/evaporator&gt; temperature is extremely low (in cooling mode) or high (in heating mode), refrigerant circuit may have defect.</p> <p>⑤ Operate in test run mode and check pipe &lt;condenser/evaporator&gt; temperature with outdoor control circuit board. If there is extreme difference with actual pipe &lt;condenser/evaporator&gt; temperature, replace indoor controller board. There is no abnormality if none of above comes within the unit. Turn the power off and on again to operate.</p> <p>( In case of checking pipe temperature with outdoor controller circuit board, be sure to connect A-control service tool (PAC-SK52ST). )</p>
E0 or E4	<p><b>Remote controller transmission error(E0)/signal receiving error(E4)</b></p> <p>① Abnormal if main or sub remote controller cannot receive normally any transmission from indoor unit of refrigerant address "0" for 3 minutes. (Error code : E0)</p> <p>② Abnormal if sub remote controller could not receive for any signal for 2 minutes. (Error code: E0)</p> <p>① Abnormal if indoor controller board can not receive any data normally from remote controller board or from other indoor controller board for 3 minutes. (Error code: E4)</p> <p>② Indoor controller board cannot receive any signal from remote controller for 2 minutes. (Error code: E4)</p>	<p>① Contact failure at transmission wire of remote controller</p> <p>② All remote controllers are set as "sub" remote controller. In this case, E0 is displayed on remote controller, and E4 is displayed at LED (LED1, LED2) on the outdoor controller circuit board.</p> <p>③ Miswiring of remote controller</p> <p>④ Defective transmitting receiving circuit of remote controller</p> <p>⑤ Defective transmitting receiving circuit of indoor controller board of refrigerant addresses "0".</p> <p>⑥ Noise has entered into the transmission wire of remote controller.</p>	<p>① Check disconnection or looseness of indoor unit or transmission wire of remote controller.</p> <p>② Set one of the remote controllers "main" if there is no problem with the action above.</p> <p>③ Check wiring of remote controller.</p> <ul style="list-style-type: none"> <li>• Total wiring length: max. 500m (Do not use cable × 3 or more.)</li> <li>• The number of connecting indoor units: max.16 units</li> <li>• The number of connecting remote controller: max. 2 units</li> </ul> <p>When it is not the above-mentioned problem of ①-③</p> <p>④ Diagnose remote controllers.</p> <p>a) When "RC OK" is displayed, remote controllers have no problem. Turn the power off, and on again to check. If abnormality generates again, replace indoor controller board.</p> <p>b) When "RC NG" is displayed, Replace remote controller.</p> <p>c) When "RC E3" or "ERC 00-06" is displayed, noise may be causing abnormality.</p> <p>* If the unit is not normal after replacing indoor controller board in group control, indoor controller board of address "0" may be abnormal.</p>
E3 or E5	<p><b>Remote controller transmission error(E3)/signal receiving error(E5)</b></p> <p>① Abnormal if remote controller could not find blank of transmission path for 6 seconds and could not transmit. (Error code: E3)</p> <p>② Remote controller receives transmitted data at the same time, compares the data, and when detecting it, judges different data to be abnormal 30 continuous times. (Error code: E3)</p> <p>① Abnormal if indoor controller board could not find blank of transmission path. (Error code: E5)</p> <p>② Indoor controller board receives transmitted data at the same time, compares the data, and when detecting it, judges different data to be abnormal 30 continuous times. (Error code: E5)</p>	<p>① 2 remote controllers are set as "main." (In case of 2 remote controllers)</p> <p>② Remote controller is connected with 2 indoor units or more.</p> <p>③ Repetition of refrigerant address</p> <p>④ Defective transmitting receiving circuit of remote controller</p> <p>⑤ Defective transmitting receiving circuit of indoor controller board</p> <p>⑥ Noise has entered into transmission wire of remote controller.</p>	<p>① Set a remote controller to main, and the other to sub.</p> <p>② Remote controller is connected with only one indoor unit.</p> <p>③ The address changes to a separate setting.</p> <p>④-⑥ Diagnose remote controller.</p> <p>a) When "RC OK" is displayed, remote controllers have no problem. Turn the power off, and on again to check. When becoming abnormal again, replace indoor controller board.</p> <p>b) When "RC NG" is displayed, replace remote controller.</p> <p>c) When "RC E3" or "ERC 00-66" is displayed, noise may be causing abnormality.</p>



Error Code	Abnormal point and detection method	Cause	Countermeasure
E6	<p><b>Indoor/outdoor unit communication error (Signal receiving error)</b></p> <p>① Abnormal if indoor controller board cannot receive any signal normally for 6 minutes after turning the power on.</p> <p>② Abnormal if indoor controller board cannot receive any signal normally for 3 minutes.</p> <p>③ Consider the unit as abnormal under the following condition: When 2 or more indoor units are connected to an outdoor unit, indoor controller board cannot receive a signal for 3 minutes from outdoor controller circuit board, a signal which allows outdoor controller circuit board to transmit signals.</p>	<p>① Contact failure, short circuit or, miswiring (converse wiring) of indoor/outdoor unit connecting wire</p> <p>② Defective transmitting receiving circuit of indoor controller board</p> <p>③ Defective transmitting receiving circuit of indoor controller board</p> <p>④ Noise has entered into indoor/outdoor unit connecting wire.</p>	<p>* Check LED display on the outdoor control circuit board. (Connect A-control service tool, PAC-SK52ST.) Refer to outdoor unit service manual.</p> <p>① Check disconnection or looseness of indoor/outdoor unit connecting wire of indoor unit or outdoor unit. Check all the units in case of twin triple indoor unit system.</p> <p>②-④ Turn the power off, and on again to check. If abnormality generates again, replace indoor controller board or outdoor controller circuit board.</p> <p>* Other indoor controller board may have defect in case of twin triple indoor unit system.</p>
E7	<p><b>Indoor/outdoor unit communication error (Transmitting error)</b></p> <p>Abnormal if "1" receiving is detected 30 times continuously though indoor controller board has transmitted "0".</p>	<p>① Defective transmitting receiving circuit of indoor controller board</p> <p>② Noise has entered into power supply.</p> <p>③ Noise has entered into outdoor control wire.</p>	<p>①-③ Turn the power off, and on again to check. If abnormality generates again, replace indoor controller board.</p>
Fb (FB)*	<p><b>Indoor controller board</b></p> <p>Abnormal if data cannot be read normally from the nonvolatile memory of the indoor controller board.</p>	<p>① Defective indoor controller board</p>	<p>① Replace indoor controller board.</p> <p>* The check code in the parenthesis indicates PAR-30MAA model.</p>
E1 or E2	<p><b>Remote controller control board</b></p> <p>① Abnormal if data cannot be read normally from the nonvolatile memory of the remote controller control board. (Error code: E1)</p> <p>② Abnormal if the clock function of remote controller cannot be operated normally. (Error code: E2)</p>	<p>① Defective remote controller</p>	<p>① Replace remote controller.</p>
PA	<p><b>Forced compressor stop (due to water leakage abnormality)</b></p> <p>① The unit has a water leakage abnormality when the following conditions, a) and b), are satisfied while the above-mentioned detection is performed.</p> <p>a) The intake temperature subtracted with liquid pipe temperature detects to be less than -10°C for a total of 30 minutes. (When the drain sensor is detected to be NOT soaked in the water, the detection record of a) and b) will be cleared.)</p> <p>b) Drain float switch detects to be in the water for more than 15 minutes.</p> <p>*Once the water leakage abnormality is detected, abnormality state will not be released until the main power is reset.</p>	<p>① Drain pump trouble</p> <p>② Drain defective</p> <ul style="list-style-type: none"> <li>· Drain pump clogging</li> <li>· Drain pipe clogging</li> </ul> <p>③ Open circuit of float switch</p> <p>④ Contact failure of float switch connector</p> <p>⑤ Dew condensation on float switch</p> <ul style="list-style-type: none"> <li>· Drain water descends along lead wire.</li> <li>· Drain water waving due to filter clogging.</li> </ul> <p>⑥ Extension piping connection difference at twin, triple, quadruple system</p> <p>⑦ Miswiring of indoor/ outdoor connecting at twin, triple, quadruple system</p> <p>⑧ Room temperature thermistor/ liquid pipe temperature thermistor detection is defective.</p>	<p>① Check the drain pump.</p> <p>② Check whether water can be drained.</p> <p>③ Check the resistance of the float switch.</p> <p>④ Check the connector contact failure.</p> <p>⑤ Check the float switch leadwire mounted. Check the filter clogging.</p> <p>⑥ Check the piping connection.</p> <p>⑦ Check the indoor/ outdoor connecting wires.</p> <p>⑧ Check the room temperature display of remote controller. Check the indoor liquid pipe temperature display of outdoor controller board.</p>
PL	<p><b>Abnormal refrigerant circuit</b></p> <p>During Cooling, Dry, or Auto Cooling operation, when the following are regarded as failures when detected for one second.</p> <p>a)The compressor continues to run for 30 or more seconds.</p> <p>b)The liquid pipe temperature or the condense/evaporator temperature is 75°C or more.</p> <p><b>*These detected errors will not be cancelled until the power source is reset.</b></p>	<p>① Abnormal operation of 4-way valve</p> <p>② Disconnection of or leakage in refrigerant pipes</p> <p>③ Air into refrigerant piping</p> <p>④ Abnormal operation (no rotation) of indoor fan</p> <ul style="list-style-type: none"> <li>· Defective fan motor.</li> <li>· Defective indoor control board.</li> </ul> <p>⑤ Defective refrigerant circuit (clogging)</p>	<p>① <b><u>When this error occurs, be sure to replace the 4-way valve.</u></b></p> <p>② Check refrigerant pipes for disconnection or leakage.</p> <p>③ After the recovery of refrigerant, vacuum dry the whole refrigerant circuit.</p> <p>④ Refer to section 10-6-2.</p> <p>⑤ Check refrigerant circuit for operation.</p> <p><b><u>*To avoid entry of moisture or air into refrigerant circuit which could cause abnormal high pressure, purge air in refrigerant circuit or replace refrigerant.</u></b></p>

## 10-4. TROUBLESHOOTING OF PROBLEMS

Note: Refer to the manual of outdoor unit for the detail of remote controller.

Phenomena	Cause	Countermeasure
<p><b>(1) LED2 on indoor controller board is off.</b></p>	<ul style="list-style-type: none"> <li>• When LED1 on indoor controller board is also off.</li> <li>① Power supply of rated voltage is not supplied to outdoor unit.</li> <li>② Defective outdoor controller circuit board</li> <li>③ Power supply of 220~240V is not supplied to indoor unit.</li> <li>④ Defective indoor controller board</li> </ul> <p><b>(For the separate indoor/outdoor unit power supply system)</b></p> <ul style="list-style-type: none"> <li>① Power supply of 220~240V AC is not supplied to indoor unit.</li> <li>② The connectors of the optional replacement kit are not used.</li> <li>③ Defective indoor controller board</li> </ul>	<ul style="list-style-type: none"> <li>① Check the voltage of outdoor power supply terminal block(L,N) or (L3,N). <ul style="list-style-type: none"> <li>• When AC220~240V is not detected, check the power wiring to outdoor unit and the breaker.</li> <li>• When AC 220~240V is detected, check ② (below).</li> </ul> </li> <li>② Check the voltage between outdoor terminal block S1 and S2. <ul style="list-style-type: none"> <li>• When AC 220~240V is not detected, check the fuse on outdoor controller circuit board, check the wiring connection.</li> <li>• When AC 220~240V is detected, check ③ (below).</li> </ul> </li> <li>③ Check the voltage between indoor terminal block S1 and S2. <ul style="list-style-type: none"> <li>• When AC 220~240V is not detected, check indoor/outdoor unit connecting wire for miswiring.</li> <li>• When AC 220~240V is detected, check ④ (below).</li> </ul> </li> <li>④ Check the fuse on indoor controller board. Check the wiring connection. If no problem are found, indoor controller board is defective.</li> </ul> <ul style="list-style-type: none"> <li>① Check the voltage of indoor power supply terminal block (L,N). <ul style="list-style-type: none"> <li>• When AC220~240V is not detected, Check the power supply wiring.</li> <li>• When AC220~240V is detected, check ② (below).</li> </ul> </li> <li>② Check that there is no problem in the method of connecting the connectors. <ul style="list-style-type: none"> <li>• When there are problems in the method of connecting the connectors. Connect the connector correctly referring to installation manual of an optional kit.</li> <li>• When there is no problem in the method of connecting the connectors, check ③ (below).</li> </ul> </li> <li>③ Check the fuse on indoor controller board. Check the wiring connection. If no problem are found, indoor controller board is defective.</li> </ul>
	<ul style="list-style-type: none"> <li>• When LED1 on indoor controller board is lit.</li> <li>① Mis-setting of refrigerant address for outdoor unit (There is no unit corresponding to refrigerant address "0".)</li> </ul>	<ul style="list-style-type: none"> <li>① Check again the setting of refrigerant address for outdoor unit. Set the refrigerant address to "0". (For grouping control system under which 2 or more outdoor units are connected, set one of the units to "0".) Set refrigerant address using SW1 (3-6) on outdoor controller circuit board.</li> </ul>

Note: Refer to the manual of outdoor unit for the detail of remote controller.

Phenomena	Cause	Countermeasure
<b>(2) LED2 on indoor controller board is blinking.</b>	<ul style="list-style-type: none"> <li>• When LED1 on indoor controller board is also blinking. Connection failure of indoor/outdoor unit connecting wire</li> <li>• When LED1 is lit.               <ul style="list-style-type: none"> <li>① Miswiring of remote controller wires Under twin triple indoor unit system, 2 or more indoor units are wired together.</li> <li>② Refrigerant address for outdoor unit is wrong or not set. Under grouping control system, there are some units whose refrigerant address is 0.</li> <li>③ Short-circuit of remote controller wires</li> <li>④ Defective remote controller</li> </ul> </li> </ul>	<p>Check indoor/outdoor unit connecting wire for connection failure.</p> <ul style="list-style-type: none"> <li>① Check the connection of remote controller wires in case of twin triple indoor unit system. When 2 or more indoor units are wired in one refrigerant system, connect remote controller wires to one of those units.</li> <li>② Check the setting of refrigerant address in case of grouping control system. If there are some units whose refrigerant addresses are 0 in one group, set one of the units to 0 using SW1 (3-6) on outdoor controller circuit board.</li> <li>③④ Remove remote controller wires and check LED2 on indoor controller board.               <ul style="list-style-type: none"> <li>• When LED2 is blinking, check the short-circuit of remote controller wires.</li> <li>• When LED2 is lit, connect remote controller wires again and: if LED2 is blinking, remote controller is defective; if LED2 is lit, connection failure of remote controller terminal block etc. has returned to normal.</li> </ul> </li> </ul>
<b>(3) Upward/downward vane performance failure</b>	<ul style="list-style-type: none"> <li>① The vane is not downward during defrosting and heat preparation and when the thermostat is OFF in HEAT mode. (Working of COOL protection function)</li> <li>② Vane motor does not rotate.               <ul style="list-style-type: none"> <li>• Defective vane motor</li> <li>• Breaking of wire or connection failure of connector</li> </ul> </li> <li>③ Upward/downward vane does not work.               <ul style="list-style-type: none"> <li>• The vane is set to fixed position.</li> </ul> </li> </ul>	<ul style="list-style-type: none"> <li>① Normal operation (The vane is set to horizontal regardless of remote control.)</li> <li>② Check ② (left).               <ul style="list-style-type: none"> <li>• Check the vane motor. (Refer to "How to check the parts".)</li> <li>• Check for breaking of wire or connection failure of connector.</li> </ul> </li> <li>③ Normal operation (Each connector on vane motor side is disconnected or setting the fixed vanes by wired remote controller.)</li> </ul>
<b>(4) Receiver for wireless remote controller</b>	<ul style="list-style-type: none"> <li>① Weak batteries of wireless remote controller</li> <li>② Contact failure of connector (CNB) on wireless remote controller board (Insert failure)</li> <li>③ Contact failure of connector (CN90) on indoor controller board (Insert failure)</li> <li>④ Contact failure of connector between wireless remote controller board and indoor controller board</li> </ul>	<ul style="list-style-type: none"> <li>① Replace batteries of wireless remote controller.</li> <li>②~④ Check contact failure of each connector. If no problems are found of connector, replace indoor controller board. When the same trouble occurs even if indoor controller board is replaced, replace wireless remote controller board.</li> </ul>

## 10-5. EMERGENCY OPERATION

### 10-5-1. When wireless remote controller fails or its battery is exhausted

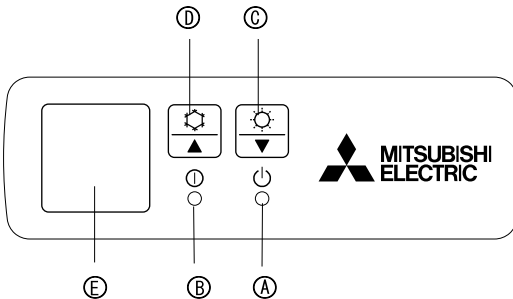

#### When the remote controller cannot be used

When the batteries of the remote controller run out or the remote controller malfunctions, the emergency operation can be done using the emergency buttons on the grille.

- Ⓐ DEFROST/STAND BY lamp
- Ⓑ Operation lamp
- Ⓒ Emergency operation switch (heating)
- Ⓓ Emergency operation switch (cooling)
- Ⓔ Receiver

#### Starting operation

- To operate the cooling mode, press the Ⓓ button for more than 2 seconds.
- To operate the heating mode, press the Ⓒ button for more than 2 seconds.

\* Lighting of the Operation lamp Ⓑ means the start of operation.

#### Note:

- Details of emergency mode are as shown below.

Operation mode	COOL	HEAT
Set temperature	24 °C	24 °C
Fan speed	High	High
Air ow direction	Horizontal	Downward 5

#### Stopping operation

- To stop operation, press the Ⓓ button or the Ⓒ button.

### 10-5-2. When wired remote controller or indoor unit microprocessor fails

1. When the wired remote control or the indoor unit microprocessor has failed, but all other components work properly, if you set the switch (SWE) on the indoor controller board ON, the indoor unit will begin emergency operation.

When emergency operation is activated, the indoor unit operates as follows:

(1) Indoor fan is running at high speed. (2) Drain pump is operating.

\* Note on the wireless remote control: when the remote control does not function, it is possible to activate emergency operation by using the indoor unit emergency operation switch (SW1, SW2 of the wireless signal receiver board).

However, if the indoor unit microprocessor has failed, it is necessary to proceed with points (2) and (3) below as in the case of the wired remote controller.

2. When you activate emergency operation of the cooling or heating, you have to set the switch (SWE) on the indoor controller board and activate emergency operation of the outdoor unit.

For details on how to activate emergency operation of the outdoor unit, refer to the outdoor unit wiring diagram.

3. Before you activate emergency operation, check the following points:

(1) Emergency operation cannot be activated when:

- the outdoor unit malfunctions.
- the indoor fan malfunctions.
- when it has detected the malfunction of drain pump during self-diagnosing.

(2) Emergency operation becomes continuous only by switching the power source on/off.

ON/OFF on the remote control or temperature control etc. does not function.

(3) Avoid operating for a long time when the outdoor unit begins defrosting while emergency operation of the heating is activated because it will start to blow cold air.

(4) Emergency cooling should be limited to 10 hours maximum (The indoor unit heat exchanger may freeze).

(5) After emergency operation has been deactivated, set the switches etc. to their original positions.

(6) Movement of the vanes does not work in emergency operation, therefore you have to slowly set them manually to the appropriate position.

## 10-6. HOW TO CHECK THE PARTS

PLA-RP35BA  
PLA-RP100BA  
PLA-RP35BA<sub>1</sub>  
PLA-RP35BAR1

PLA-RP50BA  
PLA-RP125BA  
PLA-RP50BA<sub>1</sub>  
PLA-RP50BAR1

PLA-RP60BA  
PLA-RP140BA  
PLA-RP60BA<sub>1</sub>  
PLA-RP60BAR1

PLA-RP71BA  
PLA-RP71BA<sub>1</sub>  
PLA-RP71BAR1

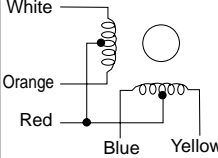
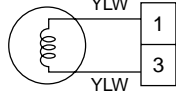
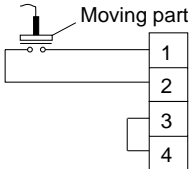
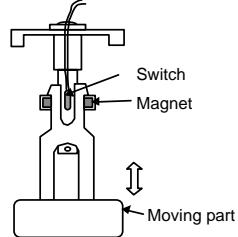
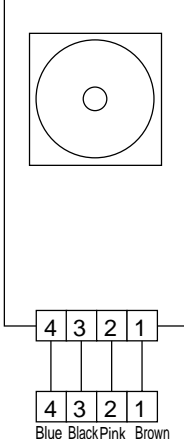
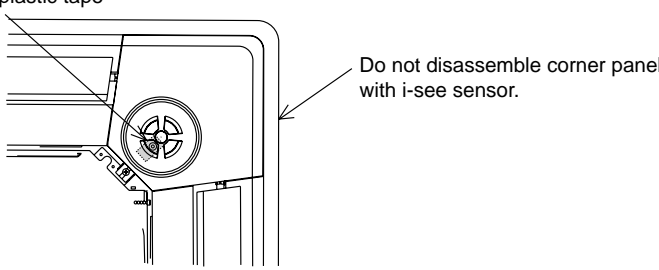
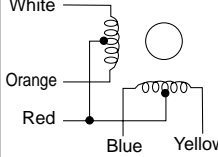
Parts name	Check points												
Room temperature thermistor (TH1) Pipe temperature thermistor/liquid (TH2) Condenser/Evaporator temperature thermistor (TH5)	Disconnect the connector then measure the resistance with a tester. (At ambient temperatures of 10°C ~30°C) <table border="1" style="margin-left: 20px;"> <thead> <tr> <th>Normal</th> <th>Abnormal</th> </tr> </thead> <tbody> <tr> <td>4.3kΩ~9.6kΩ</td> <td>Open or short</td> </tr> </tbody> </table> (Refer to the Thermistor Characteristic graph.)			Normal	Abnormal	4.3kΩ~9.6kΩ	Open or short						
Normal	Abnormal												
4.3kΩ~9.6kΩ	Open or short												
Vane motor (MV) 	Measure the resistance between the terminals with a tester. (At ambient temperatures of 20°C ~30°C) <table border="1" style="margin-left: 20px;"> <thead> <tr> <th>Connector</th> <th>Normal</th> <th>Abnormal</th> </tr> </thead> <tbody> <tr> <td>Red - Yellow (⑤-③, ⑩-⑧, ⑮-⑬, ⑳-⑱)</td> <td rowspan="5" style="text-align: center; vertical-align: middle;">300Ω</td> <td rowspan="5" style="text-align: center; vertical-align: middle;">Open or short</td> </tr> <tr> <td>Red - Blue (⑤-①, ⑩-⑥, ⑮-⑪, ⑳-⑱)</td> </tr> <tr> <td>Red - Orange (⑤-④, ⑩-⑨, ⑮-⑭, ⑳-⑲)</td> </tr> <tr> <td>Red - White (⑤-②, ⑩-⑦, ⑮-⑫, ⑳-⑰)</td> </tr> <tr> <td></td> </tr> </tbody> </table>			Connector	Normal	Abnormal	Red - Yellow (⑤-③, ⑩-⑧, ⑮-⑬, ⑳-⑱)	300Ω	Open or short	Red - Blue (⑤-①, ⑩-⑥, ⑮-⑪, ⑳-⑱)	Red - Orange (⑤-④, ⑩-⑨, ⑮-⑭, ⑳-⑲)	Red - White (⑤-②, ⑩-⑦, ⑮-⑫, ⑳-⑰)	
Connector	Normal	Abnormal											
Red - Yellow (⑤-③, ⑩-⑧, ⑮-⑬, ⑳-⑱)	300Ω	Open or short											
Red - Blue (⑤-①, ⑩-⑥, ⑮-⑪, ⑳-⑱)													
Red - Orange (⑤-④, ⑩-⑨, ⑮-⑭, ⑳-⑲)													
Red - White (⑤-②, ⑩-⑦, ⑮-⑫, ⑳-⑰)													
Drain pump (DP) 	Measure the resistance between the terminals with a tester. (Winding temperature 20°C) <table border="1" style="margin-left: 20px;"> <thead> <tr> <th>Normal</th> <th>Abnormal</th> </tr> </thead> <tbody> <tr> <td>290Ω</td> <td>Open or short</td> </tr> </tbody> </table>			Normal	Abnormal	290Ω	Open or short						
Normal	Abnormal												
290Ω	Open or short												
Drain float switch (FS) 	Measure the resistance between the terminals with a tester. <table border="1" style="margin-left: 20px;"> <thead> <tr> <th>State of moving part</th> <th>Normal</th> <th>Abnormal</th> </tr> </thead> <tbody> <tr> <td>UP</td> <td>Short</td> <td>Other than short</td> </tr> <tr> <td>DOWN</td> <td>Open</td> <td>Other than open</td> </tr> </tbody> </table>		State of moving part	Normal	Abnormal	UP	Short	Other than short	DOWN	Open	Other than open		
State of moving part	Normal	Abnormal											
UP	Short	Other than short											
DOWN	Open	Other than open											
i-see sensor (Option) 	Turn on the indoor unit with black plastic tape on the outside of the i-see sensor controller board. With electricity being turned on, measure the power voltage between connectors with a tester. The i-see sensor rotates and pull out the connector of motor for i-see sensor.  i-see sensor (At ambient temperatures of 10°C ~40°C) <table border="1" style="margin-left: 20px;"> <thead> <tr> <th>i-see sensor connector</th> <th>Normal</th> <th>Abnormal</th> </tr> </thead> <tbody> <tr> <td>②(-)—④(+)</td> <td>DC 1.857V~ 3.132V</td> <td>Other than the normal</td> </tr> <tr> <td>①(+)—②(-)</td> <td>DC 0.939V~ 1.506V</td> <td>Other than the normal</td> </tr> </tbody> </table> <b>NOTE</b> : Be careful of handling such a static electricity.			i-see sensor connector	Normal	Abnormal	②(-)—④(+)	DC 1.857V~ 3.132V	Other than the normal	①(+)—②(-)	DC 0.939V~ 1.506V	Other than the normal	
i-see sensor connector	Normal	Abnormal											
②(-)—④(+)	DC 1.857V~ 3.132V	Other than the normal											
①(+)—②(-)	DC 0.939V~ 1.506V	Other than the normal											
i-see sensor motor (MT)(Option) 	Measure the resistance between the terminals with a tester. (At ambient temperatures of 20°C ~30°C) <table border="1" style="margin-left: 20px;"> <thead> <tr> <th>Connector</th> <th>Normal</th> <th>Abnormal</th> </tr> </thead> <tbody> <tr> <td>Red - Yellow</td> <td rowspan="5" style="text-align: center; vertical-align: middle;">250Ω</td> <td rowspan="5" style="text-align: center; vertical-align: middle;">Open or short</td> </tr> <tr> <td>Red - Blue</td> </tr> <tr> <td>Red - Orange</td> </tr> <tr> <td>Red - White</td> </tr> <tr> <td></td> </tr> </tbody> </table>			Connector	Normal	Abnormal	Red - Yellow	250Ω	Open or short	Red - Blue	Red - Orange	Red - White	
Connector	Normal	Abnormal											
Red - Yellow	250Ω	Open or short											
Red - Blue													
Red - Orange													
Red - White													

### 10-6-1. Thermistor

<Thermistor Characteristic graph>

Thermistor for lower temperature

Room temperature thermistor (TH1)  
 Pipe temperature thermistor/liquid (TH2)  
 Condenser/evaporator temperature thermistor (TH5)

Thermistor  $R_0 = 15k\Omega \pm 3\%$   
 Fixed number of  $B = 3480 \pm 2\%$

$$R_t = 15 \exp \left\{ 3480 \left( \frac{1}{273+t} - \frac{1}{273} \right) \right\}$$

0°C	15kΩ
10°C	9.6kΩ
20°C	6.3kΩ
25°C	5.4kΩ
30°C	4.3kΩ
40°C	3.0kΩ

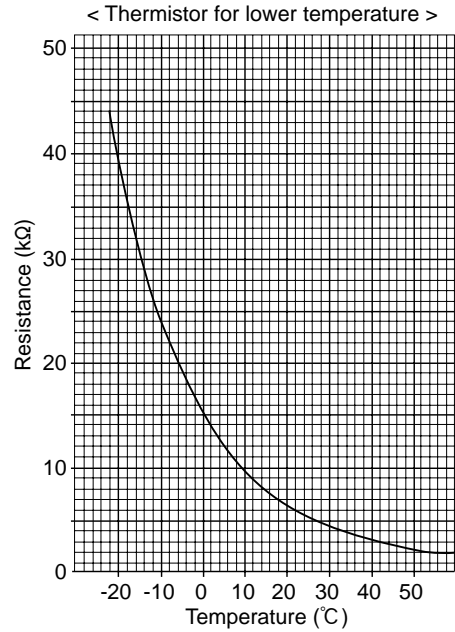

### 10-6-2. DC Fan motor (FAN MOTOR/ INDOOR CONTROLLER BOARD)

Check method of DC fan motor (fan motor / indoor controller circuit board)

① Notes

- High voltage is applied to the connector (CNMF) for the fan motor. Pay attention to the service.
- Do not pull out the connector (CNMF) for the motor with the power supply on.  
 (It causes trouble to the indoor controller circuit board and fan motor.)

② Self check

Symptom : The indoor fan cannot rotate.

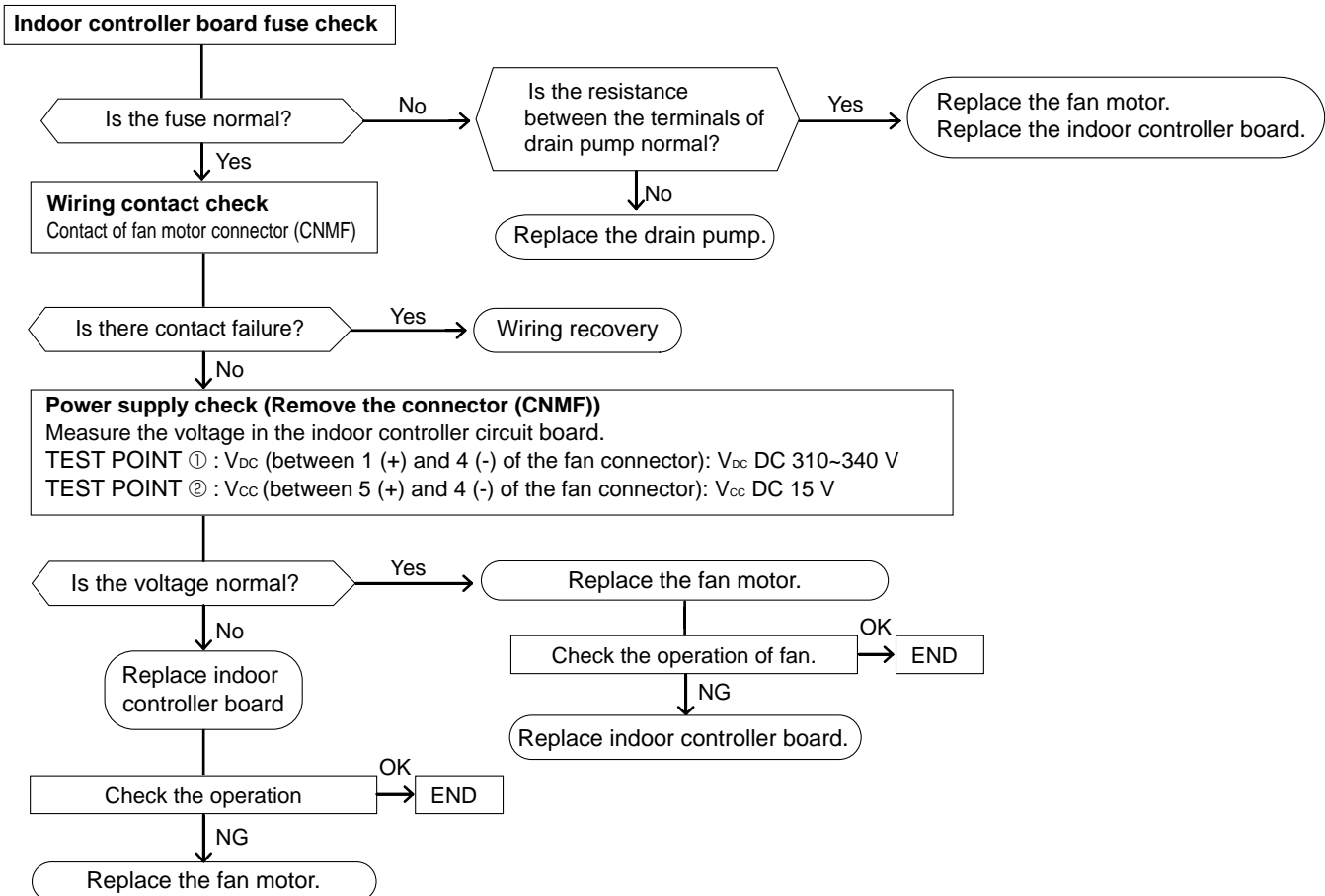



# 10-7. TEST POINT DIAGRAM

Indoor controller board

PLA-RP35BA	PLA-RP50BA	PLA-RP60BA	PLA-RP71BA
PLA-RP100BA	PLA-RP125BA	PLA-RP140BA	
PLA-RP35BA <sub>1</sub>	PLA-RP50BA <sub>1</sub>	PLA-RP60BA <sub>1</sub>	PLA-RP71BA <sub>1</sub>
PLA-RP35BAR1	PLA-RP50BAR1	PLA-RP60BAR1	PLA-RP71BAR1

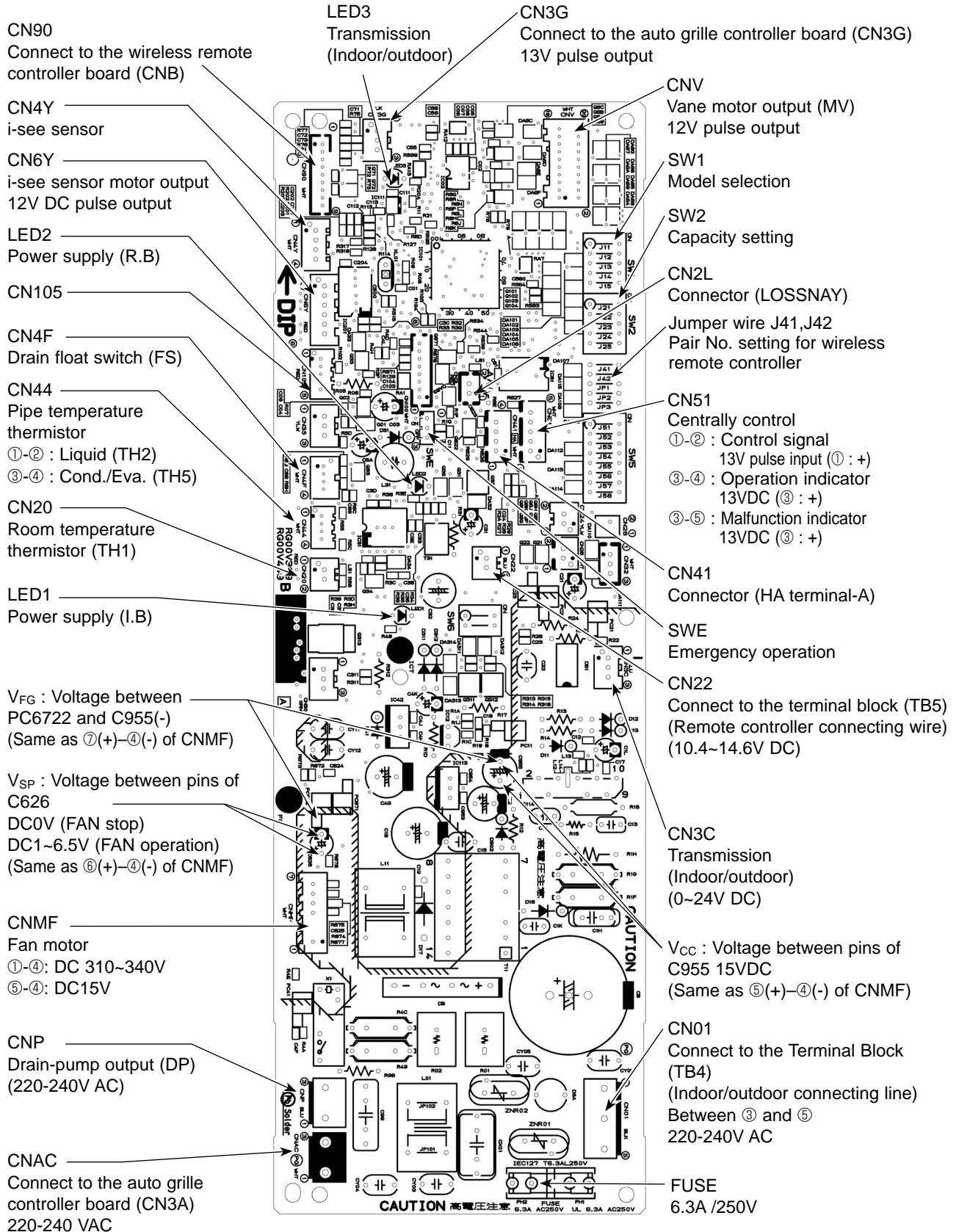

## 10-8. FUNCTIONS OF DIP SWITCH AND JUMPER WIRE

Each function is controlled by the dip switch and the jumper wire on control P.C. board.

The black square (■) indicates a switch position

(Marks in the table below) Jumper wire (○ : Short × : Open)

Jumper wire	Functions	Setting by the dip switch and jumper wire	Remarks																																																																																																								
SW1	Model settings	<table border="1"> <thead> <tr> <th>MODEL</th> <th>Manufacture/Service</th> </tr> </thead> <tbody> <tr> <td>PLA-RP-BA</td> <td> <table border="1"> <tr> <td>1</td><td>2</td><td>3</td><td>4</td><td>5</td> <td>ON</td> </tr> <tr> <td>■</td><td>■</td><td>■</td><td>■</td><td>■</td> <td>OFF</td> </tr> </table> </td> </tr> </tbody> </table>	MODEL	Manufacture/Service	PLA-RP-BA	<table border="1"> <tr> <td>1</td><td>2</td><td>3</td><td>4</td><td>5</td> <td>ON</td> </tr> <tr> <td>■</td><td>■</td><td>■</td><td>■</td><td>■</td> <td>OFF</td> </tr> </table>	1	2	3	4	5	ON	■	■	■	■	■	OFF																																																																																									
MODEL	Manufacture/Service																																																																																																										
PLA-RP-BA	<table border="1"> <tr> <td>1</td><td>2</td><td>3</td><td>4</td><td>5</td> <td>ON</td> </tr> <tr> <td>■</td><td>■</td><td>■</td><td>■</td><td>■</td> <td>OFF</td> </tr> </table>	1	2	3	4	5	ON	■	■	■	■	■	OFF																																																																																														
1	2	3	4	5	ON																																																																																																						
■	■	■	■	■	OFF																																																																																																						
SW2	Capacity settings	<table border="1"> <thead> <tr> <th>MODELS</th> <th>Manufacture/Service</th> <th>MODELS</th> <th>Manufacture/Service</th> </tr> </thead> <tbody> <tr> <td>PLA-RP35BA</td> <td> <table border="1"> <tr> <td>1</td><td>2</td><td>3</td><td>4</td><td>5</td> <td>ON</td> </tr> <tr> <td>■</td><td>■</td><td>■</td><td>■</td><td>■</td> <td>OFF</td> </tr> </table> </td> <td>PLA-RP100BA</td> <td> <table border="1"> <tr> <td>1</td><td>2</td><td>3</td><td>4</td><td>5</td> <td>ON</td> </tr> <tr> <td>■</td><td>■</td><td>■</td><td>■</td><td>■</td> <td>OFF</td> </tr> </table> </td> </tr> <tr> <td>PLA-RP50BA</td> <td> <table border="1"> <tr> <td>1</td><td>2</td><td>3</td><td>4</td><td>5</td> <td>ON</td> </tr> <tr> <td>■</td><td>■</td><td>■</td><td>■</td><td>■</td> <td>OFF</td> </tr> </table> </td> <td>PLA-RP125BA</td> <td> <table border="1"> <tr> <td>1</td><td>2</td><td>3</td><td>4</td><td>5</td> <td>ON</td> </tr> <tr> <td>■</td><td>■</td><td>■</td><td>■</td><td>■</td> <td>OFF</td> </tr> </table> </td> </tr> <tr> <td>PLA-RP60BA</td> <td> <table border="1"> <tr> <td>1</td><td>2</td><td>3</td><td>4</td><td>5</td> <td>ON</td> </tr> <tr> <td>■</td><td>■</td><td>■</td><td>■</td><td>■</td> <td>OFF</td> </tr> </table> </td> <td>PLA-RP140BA</td> <td> <table border="1"> <tr> <td>1</td><td>2</td><td>3</td><td>4</td><td>5</td> <td>ON</td> </tr> <tr> <td>■</td><td>■</td><td>■</td><td>■</td><td>■</td> <td>OFF</td> </tr> </table> </td> </tr> <tr> <td>PLA-RP71BA</td> <td> <table border="1"> <tr> <td>1</td><td>2</td><td>3</td><td>4</td><td>5</td> <td>ON</td> </tr> <tr> <td>■</td><td>■</td><td>■</td><td>■</td><td>■</td> <td>OFF</td> </tr> </table> </td> <td></td> <td></td> </tr> </tbody> </table>	MODELS	Manufacture/Service	MODELS	Manufacture/Service	PLA-RP35BA	<table border="1"> <tr> <td>1</td><td>2</td><td>3</td><td>4</td><td>5</td> <td>ON</td> </tr> <tr> <td>■</td><td>■</td><td>■</td><td>■</td><td>■</td> <td>OFF</td> </tr> </table>	1	2	3	4	5	ON	■	■	■	■	■	OFF	PLA-RP100BA	<table border="1"> <tr> <td>1</td><td>2</td><td>3</td><td>4</td><td>5</td> <td>ON</td> </tr> <tr> <td>■</td><td>■</td><td>■</td><td>■</td><td>■</td> <td>OFF</td> </tr> </table>	1	2	3	4	5	ON	■	■	■	■	■	OFF	PLA-RP50BA	<table border="1"> <tr> <td>1</td><td>2</td><td>3</td><td>4</td><td>5</td> <td>ON</td> </tr> <tr> <td>■</td><td>■</td><td>■</td><td>■</td><td>■</td> <td>OFF</td> </tr> </table>	1	2	3	4	5	ON	■	■	■	■	■	OFF	PLA-RP125BA	<table border="1"> <tr> <td>1</td><td>2</td><td>3</td><td>4</td><td>5</td> <td>ON</td> </tr> <tr> <td>■</td><td>■</td><td>■</td><td>■</td><td>■</td> <td>OFF</td> </tr> </table>	1	2	3	4	5	ON	■	■	■	■	■	OFF	PLA-RP60BA	<table border="1"> <tr> <td>1</td><td>2</td><td>3</td><td>4</td><td>5</td> <td>ON</td> </tr> <tr> <td>■</td><td>■</td><td>■</td><td>■</td><td>■</td> <td>OFF</td> </tr> </table>	1	2	3	4	5	ON	■	■	■	■	■	OFF	PLA-RP140BA	<table border="1"> <tr> <td>1</td><td>2</td><td>3</td><td>4</td><td>5</td> <td>ON</td> </tr> <tr> <td>■</td><td>■</td><td>■</td><td>■</td><td>■</td> <td>OFF</td> </tr> </table>	1	2	3	4	5	ON	■	■	■	■	■	OFF	PLA-RP71BA	<table border="1"> <tr> <td>1</td><td>2</td><td>3</td><td>4</td><td>5</td> <td>ON</td> </tr> <tr> <td>■</td><td>■</td><td>■</td><td>■</td><td>■</td> <td>OFF</td> </tr> </table>	1	2	3	4	5	ON	■	■	■	■	■	OFF			
MODELS	Manufacture/Service	MODELS	Manufacture/Service																																																																																																								
PLA-RP35BA	<table border="1"> <tr> <td>1</td><td>2</td><td>3</td><td>4</td><td>5</td> <td>ON</td> </tr> <tr> <td>■</td><td>■</td><td>■</td><td>■</td><td>■</td> <td>OFF</td> </tr> </table>	1	2	3	4	5	ON	■	■	■	■	■	OFF	PLA-RP100BA	<table border="1"> <tr> <td>1</td><td>2</td><td>3</td><td>4</td><td>5</td> <td>ON</td> </tr> <tr> <td>■</td><td>■</td><td>■</td><td>■</td><td>■</td> <td>OFF</td> </tr> </table>	1	2	3	4	5	ON	■	■	■	■	■	OFF																																																																																
1	2	3	4	5	ON																																																																																																						
■	■	■	■	■	OFF																																																																																																						
1	2	3	4	5	ON																																																																																																						
■	■	■	■	■	OFF																																																																																																						
PLA-RP50BA	<table border="1"> <tr> <td>1</td><td>2</td><td>3</td><td>4</td><td>5</td> <td>ON</td> </tr> <tr> <td>■</td><td>■</td><td>■</td><td>■</td><td>■</td> <td>OFF</td> </tr> </table>	1	2	3	4	5	ON	■	■	■	■	■	OFF	PLA-RP125BA	<table border="1"> <tr> <td>1</td><td>2</td><td>3</td><td>4</td><td>5</td> <td>ON</td> </tr> <tr> <td>■</td><td>■</td><td>■</td><td>■</td><td>■</td> <td>OFF</td> </tr> </table>	1	2	3	4	5	ON	■	■	■	■	■	OFF																																																																																
1	2	3	4	5	ON																																																																																																						
■	■	■	■	■	OFF																																																																																																						
1	2	3	4	5	ON																																																																																																						
■	■	■	■	■	OFF																																																																																																						
PLA-RP60BA	<table border="1"> <tr> <td>1</td><td>2</td><td>3</td><td>4</td><td>5</td> <td>ON</td> </tr> <tr> <td>■</td><td>■</td><td>■</td><td>■</td><td>■</td> <td>OFF</td> </tr> </table>	1	2	3	4	5	ON	■	■	■	■	■	OFF	PLA-RP140BA	<table border="1"> <tr> <td>1</td><td>2</td><td>3</td><td>4</td><td>5</td> <td>ON</td> </tr> <tr> <td>■</td><td>■</td><td>■</td><td>■</td><td>■</td> <td>OFF</td> </tr> </table>	1	2	3	4	5	ON	■	■	■	■	■	OFF																																																																																
1	2	3	4	5	ON																																																																																																						
■	■	■	■	■	OFF																																																																																																						
1	2	3	4	5	ON																																																																																																						
■	■	■	■	■	OFF																																																																																																						
PLA-RP71BA	<table border="1"> <tr> <td>1</td><td>2</td><td>3</td><td>4</td><td>5</td> <td>ON</td> </tr> <tr> <td>■</td><td>■</td><td>■</td><td>■</td><td>■</td> <td>OFF</td> </tr> </table>	1	2	3	4	5	ON	■	■	■	■	■	OFF																																																																																														
1	2	3	4	5	ON																																																																																																						
■	■	■	■	■	OFF																																																																																																						
J41 J42	Pair number setting with wireless remote controller	<table border="1"> <thead> <tr> <th rowspan="2">Wireless remote controller setting</th> <th colspan="2">Control PCB setting</th> </tr> <tr> <th>J41</th> <th>J42</th> </tr> </thead> <tbody> <tr> <td>0</td> <td>○</td> <td>○</td> </tr> <tr> <td>1</td> <td>×</td> <td>○</td> </tr> <tr> <td>2</td> <td>○</td> <td>×</td> </tr> <tr> <td>3 ~ 9</td> <td>×</td> <td>×</td> </tr> </tbody> </table>	Wireless remote controller setting	Control PCB setting		J41	J42	0	○	○	1	×	○	2	○	×	3 ~ 9	×	×	<p>&lt;Settings at time of factory shipment&gt;            Wireless remote controller: 0            Control PCB: ○ (for both J41 and J42)            Four pair number settings are supported.            The pair number settings of the wireless remote controller and indoor control PCB (J41/J42) are given in the table on the left.            ('×' in the table indicates the jumper wire is disconnected.)</p>																																																																																							
Wireless remote controller setting	Control PCB setting																																																																																																										
	J41	J42																																																																																																									
0	○	○																																																																																																									
1	×	○																																																																																																									
2	○	×																																																																																																									
3 ~ 9	×	×																																																																																																									
JP1	Unit type setting	<table border="1"> <thead> <tr> <th>Model</th> <th>JP1</th> </tr> </thead> <tbody> <tr> <td>Without TH5</td> <td>○</td> </tr> <tr> <td>With TH5</td> <td>×</td> </tr> </tbody> </table>	Model	JP1	Without TH5	○	With TH5	×	There is no jumper (JP1) because these models have the cond./eva. temperature thermistor (TH5).																																																																																																		
Model	JP1																																																																																																										
Without TH5	○																																																																																																										
With TH5	×																																																																																																										
JP3	Indoor controller board type setting	<table border="1"> <thead> <tr> <th>Indoor controller board type</th> <th>JP3</th> </tr> </thead> <tbody> <tr> <td>Factory shipment</td> <td>×</td> </tr> <tr> <td>Service parts</td> <td>○</td> </tr> </tbody> </table>	Indoor controller board type	JP3	Factory shipment	×	Service parts	○																																																																																																			
Indoor controller board type	JP3																																																																																																										
Factory shipment	×																																																																																																										
Service parts	○																																																																																																										

# 11 SPECIAL FUNCTION

## 11-1. HOW TO PERFORM THE UP/DOWN OPERATION OF THE AIR INTAKE GRILLE

### 11-1.1. Setting up the lowering distance of air intake grille

You can set up 8 different stages of lowering distance for the air intake grille according to the set up location if desired.

\* As a factory default, the decorative panel will automatically stop at 1.6 m from the ceiling level. The distance is a rough indication, check by actually lowering it.

- 1) Take the cover off the electric box of the decorative panel. (2 screws)
- 2) Set up the dip switches of SW22 or SW2 on the control board of the decorative panel as followed.

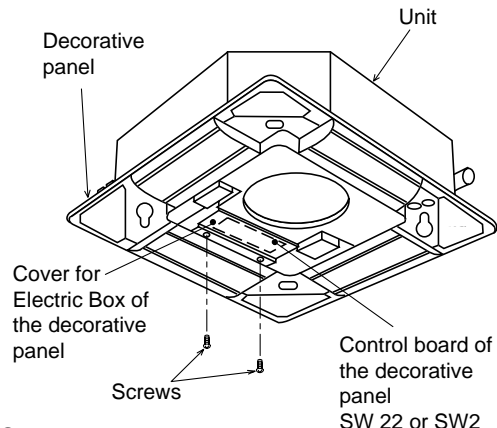

#### Dip SW 22

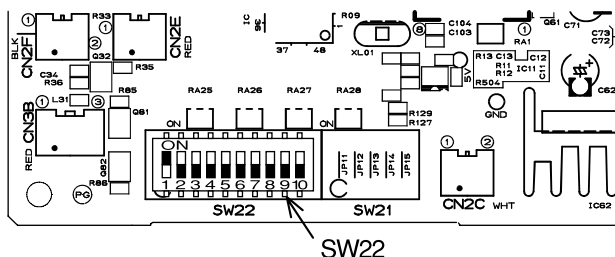

The black square (■) indicates a switch position.

Lowering distance (Rough indication of the ceiling height)	SW22 (Lowering distance)	Lowering distance (Rough indication of the ceiling height)	SW22 (Lowering distance)
1.2m (~ 2.4m)	ON OFF ■■■■■■■■ 1 2 3 4 5 6 7 8 9 10	1.6m (2.4m ~ 2.8m)	Initial setting ON OFF ■■■■■■■■ 1 2 3 4 5 6 7 8 9 10
2.0m (2.8m ~ 3.2m)	ON OFF ■■■■■■■■ 1 2 3 4 5 6 7 8 9 10	2.4m (3.2m ~ 3.6m)	ON OFF ■■■■■■■■ 1 2 3 4 5 6 7 8 9 10
2.8m (3.6m ~ 4.0m)	ON OFF ■■■■■■■■ 1 2 3 4 5 6 7 8 9 10	3.2m (4.0m ~ 4.4m)	ON OFF ■■■■■■■■ 1 2 3 4 5 6 7 8 9 10
3.6m (4.4m ~ 4.8m)	ON OFF ■■■■■■■■ 1 2 3 4 5 6 7 8 9 10	4.0m (4.8m ~ 5.2m)	ON OFF ■■■■■■■■ 1 2 3 4 5 6 7 8 9 10

\* Airflow outreach distance is different depending on indoor units and air volume (ceiling height), so airflow may not reach the indicated ceiling height as shown in the above table.

- 3) Put the cover back on the electric box of the decorative panel.

#### Dip SW 2

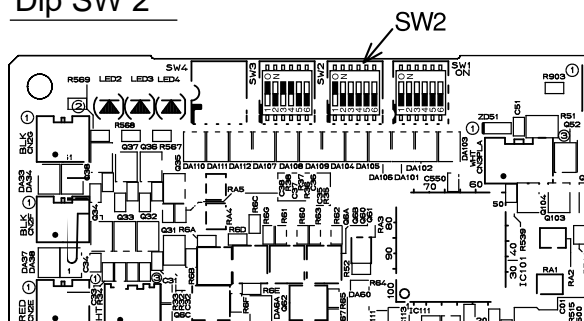

The black square (■) indicates a switch position.

Lowering distance (Rough indication of the ceiling height)	SW2 (Lowering distance)	Lowering distance (Rough indication of the ceiling height)	SW2 (Lowering distance)
1.2m (~ 2.4m)	ON OFF ■■■■■■ 1 2 3 4 5 6	1.6m (2.4m ~ 2.8m)	Initial setting ON OFF ■■■■■■ 1 2 3 4 5 6
2.0m (2.8m ~ 3.2m)	ON OFF ■■■■■■ 1 2 3 4 5 6	2.4m (3.2m ~ 3.6m)	ON OFF ■■■■■■ 1 2 3 4 5 6
2.8m (3.6m ~ 4.0m)	ON OFF ■■■■■■ 1 2 3 4 5 6	3.2m (4.0m ~ 4.4m)	ON OFF ■■■■■■ 1 2 3 4 5 6
3.6m (4.4m ~ 4.8m)	ON OFF ■■■■■■ 1 2 3 4 5 6	4.0m (4.8m ~ 5.2m)	ON OFF ■■■■■■ 1 2 3 4 5 6

\* Airflow outreach distance is different depending on indoor units and air volume (ceiling height), so airflow may not reach the indicated ceiling height as shown in the above table.

### 11-1-2. How to perform the up/down operation using wireless remote controller

**Warning:** Ensure that the air-conditioner is not running.  
• Otherwise, it may cause an injury or a failure.

1) Ensure that the air-conditioner is not running.

2) Press the "Down" button to lower the air intake grille.

\* By default, the air intake grille will automatically stop at a lowering distance of 1.6 m from the ceiling level. The distance can be changed to 1.2 m, 2.0 m, 2.4 m, 2.8 m, 3.2 m, 3.6 m and 4.0 m. These should be used only as a guide. You should lower the air intake grille yourself to check the exact distance.

\* When you want to stop the air intake grille while it is lowering, press the "Stop" or "Up" button on the remote controller to stop at that position.

3) Remove the filter or air intake grille and clean them.

4) Attach the filter and air intake grille.

5) Press the "Up" button on the remote controller to put the air intake grille in place.

\* If the air intake grille is not placed in the correct position at a time, the operation is automatically retried.

\* When you want to stop the air intake grille while it is rising, press the "Stop" or "Down" button on the remote controller to stop at that position.

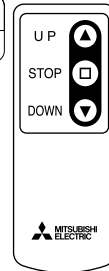

Wireless remote controller for Automatic Filter Elevation Panel

### 11-1-3. How to perform the up/down operation using wired remote controller (PAR-30MAA)

① Select "Maintenance" from the Main menu, and press the button.



Select "Auto descending panel" with the **F1** or **F2** button, and press the button.

\* When using the automatic filter elevation panel (auto descending panel), always set the "Address" and "Unit No." with "Service" – "Function setting".

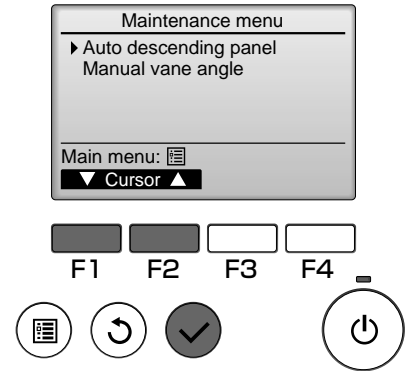

② Move the cursor to "Ref. address", "Unit No." or "Operation" with the **F1** button to select.



Select the refrigerant address and the unit number for the units to whose falls panel, with the **F2** or **F3** button, and press the button.

- Ref. address: Refrigerant address
- Unit No.: 1, 2, 3, 4, All
- Operation: Down / Up



Press the **F4** button to confirm the unit.

<Confirmation of target unit>  
If the unit being set is unknown, make the setting and then press the **F4** button to confirm.  
The air conditioner which is blowing downward is the target air conditioner.

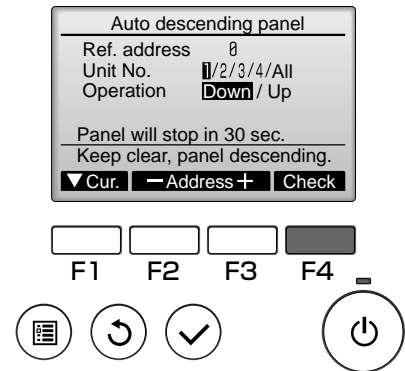
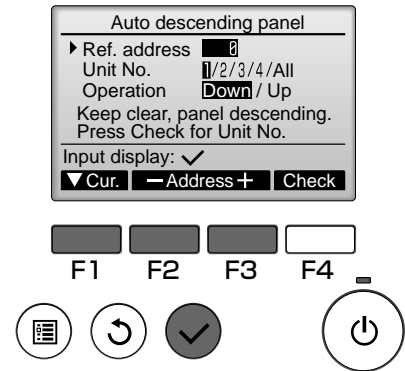

**Navigating through the screens**

- To go back to the Main menu ..... button
- To return to the previous screen..... button

## 11-1-4. How to perform the up/down operation using wired remote controller (PAR-21MAA)

### ■ General Operation

- \* Raise or lower all the air intake grilles managed by the remote controller at the same time.
- Install the remote controller in a place where you can observe all the air-conditioners. Otherwise, the lowering grille may make contact with something and cause damage to it.

#### 1) Ensure that the air-conditioner is not running.

- \* The up/down operation mode is only available when the air-conditioner is "OFF".

**Warning:** Ensure that the air-conditioner is not running.  
• Otherwise, it may cause an injury or a failure.

#### 2) Press both the "FILTER" and "Ventilation" buttons simultaneously for 2 seconds or more to enter the up/down operation mode.

"Up/down operation mode" display



#### 3) Press the TEMP. (▽) button. After a while, the air intake grille will begin lowering.

"Stand by for lowering" display

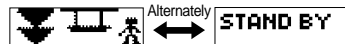

"Lowering" display (blinking)



"Stopped" display (when finished lowering)

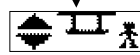

#### [ Note: ]

- You cannot stop the operation while the air intake grille is lowering.
- \* If you press the (△) button while the air intake grille is moving down, the air intake grille may stop lowering, but it will not stop immediately.
- In initial setting, the air intake grille will automatically stop at the lowering distance of 1.6 m from the ceiling level.
- \* The distance can be changed to 1.2 m, 2.0 m, 2.4 m, 2.8 m, 3.2 m, 3.6 m, and 4.0 m. These should be used only as a guide. You should lower the air intake grille yourself to check the exact distance.

#### 4) Remove the filter and/or air intake grille to clean them.

#### 5) Press the TEMP. (△) button. After a while, the air intake grille will begin to rise and then be put back into place.

"Stand by for raising" display

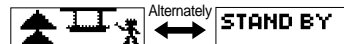

"Raising" display (blinking)



"Stopped" display (when the air intake grille has been put back into place)



#### [ Note: ]

- You cannot stop the operation while the air intake grille is rising.
- \* If you press the (▽) button while the air intake grille is moving up, the air intake grille may stop rising, but it will not stop immediately.

#### 6) Exit the up/down mode either by pressing the "ON/OFF" button or by pressing both the "FILTER" and "Ventilation" buttons simultaneously for 2 seconds or more.

- \* After exiting the up/down mode, wait for about 30 seconds to perform the next operation. The remote controller will not accept any operation for that period.

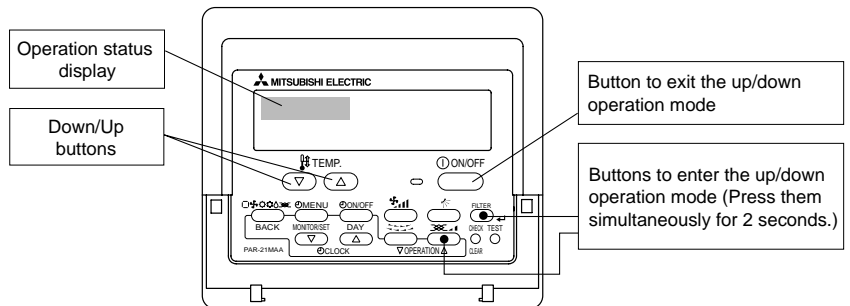

**■ Up/down operation on the individual specified indoor units (when used in combination with Mr. SLIM model)**  
 \* Raise or lower the air intake grille of the specific indoor unit that you select from all that are managed by that remote controller.

1) Ensure that the air-conditioner is not running.  
 \* The up/down operation mode is only available when the indoor unit is "OFF".

**Warning:** Ensure that the indoor unit is not running.  
 • Otherwise, it may cause an injury or a failure.

2) Press both the "FILTER" and "Ventilation" buttons simultaneously for 2 seconds or more to enter the up/down operation mode.

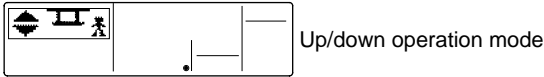

3) Press the "Ventilation" button. After a while, it will switch to the "individually-specified up/down operation mode".

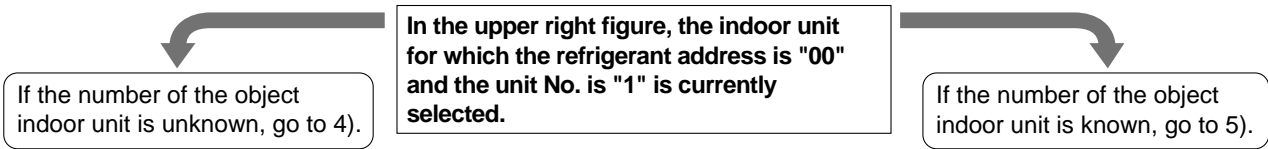
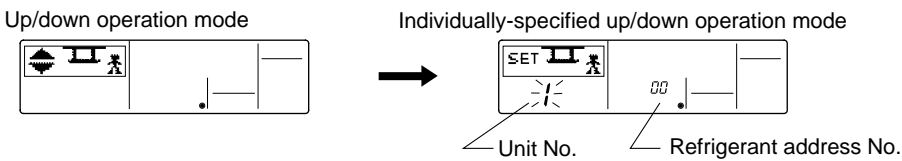

In the upper right figure, the indoor unit for which the refrigerant address is "00" and the unit No. is "1" is currently selected.

4) If you press the "FILTER" button when the "Unit No." or "Refrigerant address No." is blinking, after a while, the up/down airflow direction of the displayed indoor unit will be switched downward; and the airflow direction of the other vents will all be blocked.

■ In Step 5) described below, identify the object indoor unit by changing the "Unit No." and "Refrigerant address No." and by pressing the "FILTER" button to check the up/down airflow direction.

**[Remarks:]**  
 ■ If "Err" is displayed when you press the "FILTER" button to check the object indoor unit, the indoor unit with that "Unit No." or "Refrigerant address" may not exist. Check and set that indoor unit again.

5) Select the "Unit No." and "Refrigerant address No.".

■ "Unit No." and "Refrigerant address No." can be changed by using the "TEMP." buttons (▽) (△) when the panel displays (a) or (b).

■ Every time you press the "Mode selection" button, the target of operation will change as illustrated below.

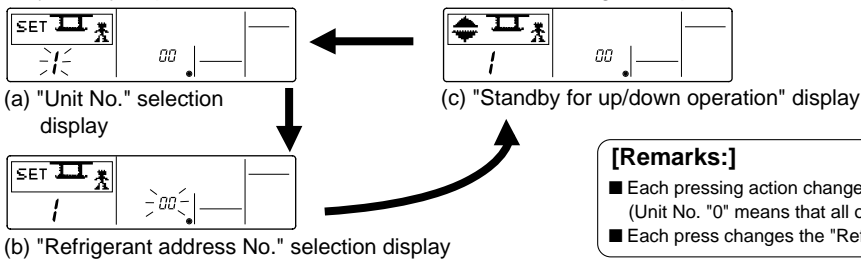

**[Remarks:]**  
 ■ Each pressing action changes the unit No. from "1 - 4" to "0". (Unit No. "0" means that all of 1 - 4 are targeted.)  
 ■ Each press changes the "Refrigerant address" from "0" to "15".

6) Continue to press the "Mode selection" button until "Waiting for up/down operation" is displayed.

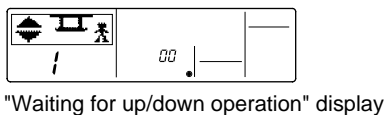

The following steps are the same as steps 3) - 6) described in the "General Operation" section. Refer to that section.

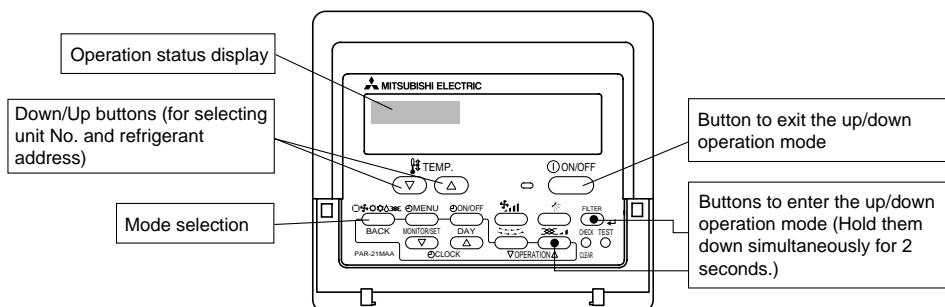

## 11-2. OPERATION (AUTO DESCENDING PANEL : PLP-6BAJ)

### (1) Normal operation

#### ① UP/DOWN

Air intake grille is raised/lowered by commands of UP and DOWN.

Air intake grille does not move under the state of no-load detection or obstacle detection.

Air intake grille stops automatically at the set lowering distance from the ceiling level.

#### ② STOP

It stops in the cases below :

- When it reaches at the set lowering distance from the ceiling level.  
It automatically stops after a predetermined period of lowering.
- When it is stored in the panel.

The air intake grille is judged to be stored in the panel when the storage detection switch is pressed for 3 seconds continuously.

- When receiving commands of STOP, DOWN while moving up or UP while moving down.

The STOP button is only available on the automatic filter elevation panel remote controller.

When the wired remote controller is used, there will be a slight delay in stopping due to transmission speed.

- When both wire 1b and wire 2b are not loaded.

Only the wire b in each UP/DOWN Machine has a tension detection switch.

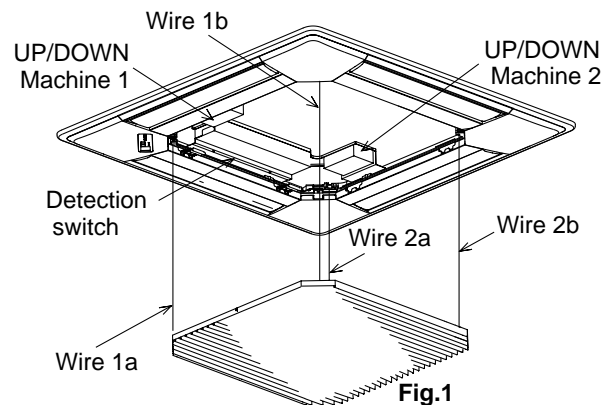

### (2) Special operation

#### ① Storage operation

Case : Obstruction of the raising grille before storage or malfunction of storage detection switch

Storage operation will be performed when the intake grille has been raised the set distance but the storage detection switch is not engaged.

In this case, the operation below will be repeated up to 4 times.

10 cm down → 30 cm up → ... → 10 cm down → 30 cm up

#### ② No-load detection

Case : UP/DOWN commands with no grille suspended.

When both wire 1b and wire 2b are not loaded, the wires will not move.

#### ③ Obstacle detection

Case : Making contact with something while lowering.

Should the loads on the wire 1b and wire 2b be removed due to the grille making contact with something while lowering, the lowering operation will stop. The grille will then be raised 10 cm and stop again.

#### [Emergency operation]

- When the wireless remote controller cannot be used (in the case of battery discharge, misplacing of the wireless remote controller, malfunctioning and so on), the emergency switch on the receiver can be used as an alternative.

\* When doing this, particular caution must be taken not to fall.

To lower the air intake grille : Press the  button once.

(For emergency heating operation, press and hold this button.)

To raise the air intake grille : Press the  button once.

(For emergency cooling operation, press and hold this button.)

- To stop the air intake grille from moving, use the opposite buttons to those used to initiate movement.  
(To stop it from lowering, press the UP button; To stop it from rising, press the Down button.)
- If up/down machine is out of order, fix air intake grille temporarily and the indoor unit can be operated.  
※ For details, refer to installation manual for the attachment of grille.

# 11-3. ELECTRICAL CIRCUIT (Controller board and wiring diagram (Panel))

## 11-3-1. Dip SW 22 type

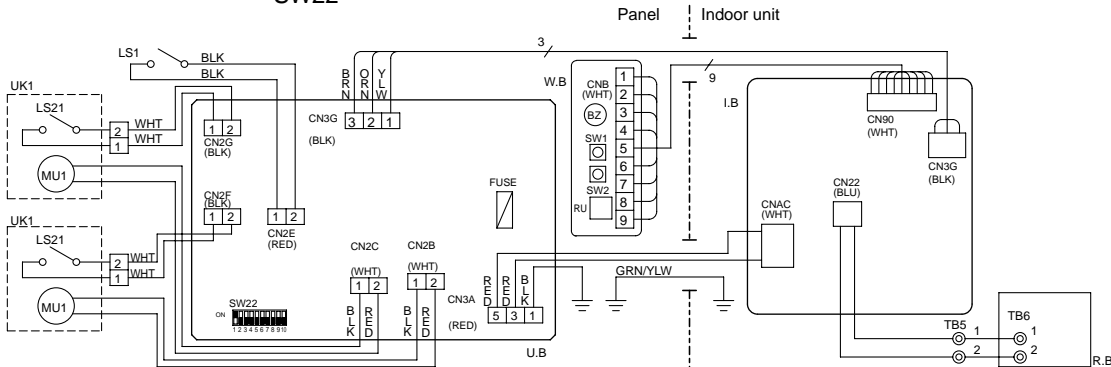
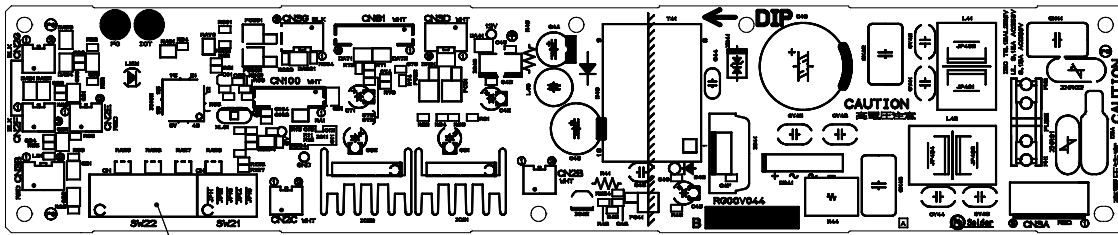

Symbol	Name	Symbol	Name
U.B	Auto grille controller board	W.B	Wireless remote controller board
FUSE	Fuse (3.15A)	BZ	Buzzer
SW22	Switch (Lowering distance set up)	RU	Receiver
UK1	Up/down machine	SW1	Emergency switch (heating/down)
MU1	Motor (Up/down)	SW2	Emergency switch (cooling/up)
LS21	Limit switch (tension detection)	LS1	Limit switch (storage detection)
I.B	Indoor controller board	R.B	Wired remote controller

## 11-3-2. Dip SW 2 type

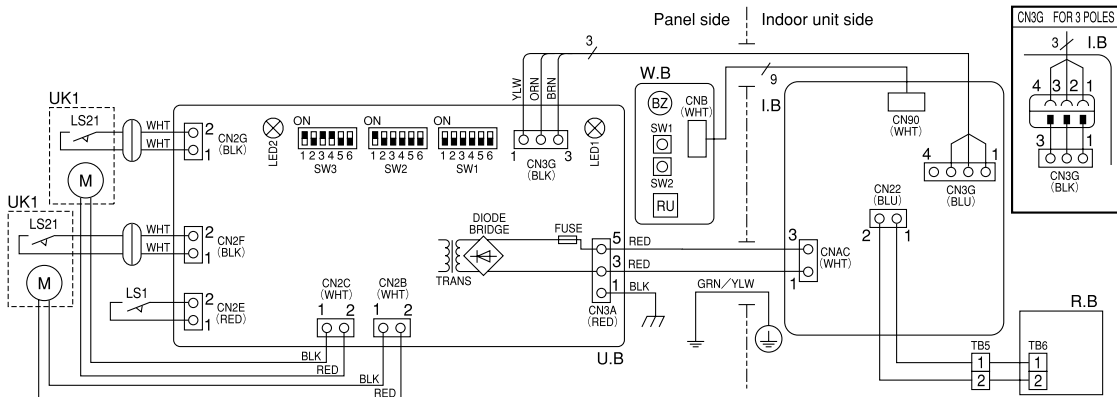
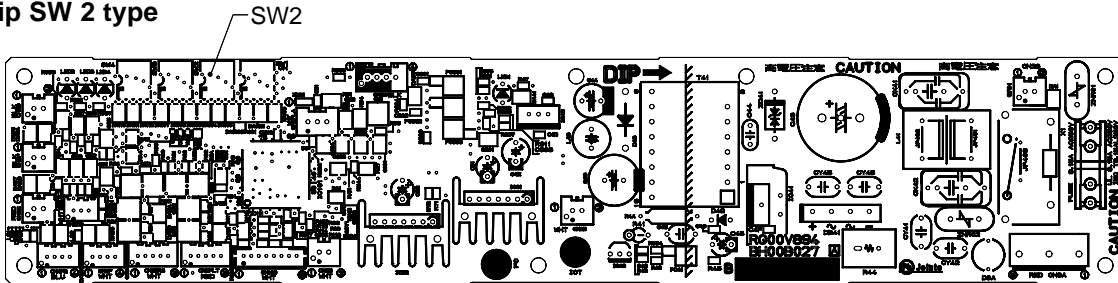

[LEGEND]

SYMBOL	NAME	SYMBOL	NAME	SYMBOL	NAME
U.B	CONTROLLER BOARD	I.B	INDOOR UNIT CONTROLLER BOARD	UK1	UP/DOWN MACHINE
FUSE	FUSE (T3.15A/250V)	W.B	WIRELESS SIGNAL RECEIVER BOARD	M	MOTOR (FOR GRILLE UP/DOWN)
SW1	SWITCH (MODEL SELECTION)	BZ	BUZZER	LS21	LIMIT SWITCH (TENSION DETECTION)
SW2	SWITCH (LOWERING DISTANCE)	RU	RECEIVING UNIT	LS1	LIMIT SWITCH (STORAGE DETECTION)
SW3	SWITCH (SYSTEM SELECTION)	SW1	EMERGENCY HEATING (LONG PRESS FOR OVER 2 SEC)	R.B.	WIRED REMOTE CONTROLLER
LED1	LED RED (MICROPROCESSOR POWER)	SW2	EMERGENCY COOLING (LONG PRESS FOR OVER 2 SEC)		
LED2	LED RED (GRILLE CONDITION)				



## 11-4. TROUBLESHOOTING

- Check the following points.

Problem	Possible Reason	Corrective Action
Air intake grille does not function under operation of the wireless remote controller.	Air-conditioner is running.	Stop running the air-conditioner and try again.
	Power failure	After recovering from power failure, try again.
	Batteries are not inserted into the wireless remote controller. Or battery power is running low.	Install or replace the battery.
	There is something on the air intake grille. Or something is stuck in the air intake grille.	Remove the objects or obstacles from the air intake grille. Or, remove the stuck object.
Air intake grille cannot be fixed in place.	There is something on the air intake grille.	Remove the objects or obstacles from the air intake grille.
	Filter is not properly installed.	Lower the air intake grille again and check whether the filter is installed in the correct position.
	Air intake grille is not hung with all 4 hooks.	Lower the air intake grille again and hook on the air intake grille.
Air intake grille stops lowering. (Air intake grille would not lower any further.)	The air intake grille has finished lowering to the auto-stop position.	This is normal.
Noises are made during up/down operation. (While air intake grille is moving up/down.)	This is the noise made when the wire is wound and unwound.	This is normal.
Noises are made while putting the air intake grille into place.	This is the operational noise for putting the air intake grille into place.	
Air intake grille repeats rising and lowering several times while being put into place.	This is the operation for putting the air intake grille into place.	
Air intake grille leans toward one side during the up/down operation.	The speeds of winding/unwinding wires are slightly different for each wire.	

PLA-RP35BA  
 PLA-RP100BA  
 PLA-RP35BA<sub>1</sub>  
 PLA-RP35BAR1

PLA-RP50BA  
 PLA-RP125BA  
 PLA-RP50BA<sub>1</sub>  
 PLA-RP50BAR1

PLA-RP60BA  
 PLA-RP140BA  
 PLA-RP60BA<sub>1</sub>  
 PLA-RP60BAR1

PLA-RP71BA  
 PLA-RP71BA<sub>1</sub>  
 PLA-RP71BAR1

Be careful when removing heavy parts.

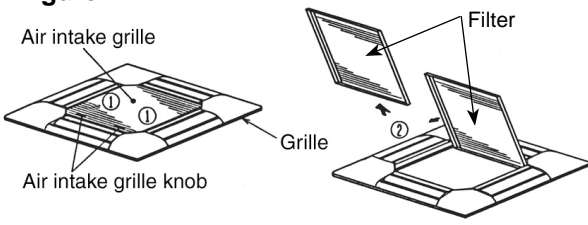
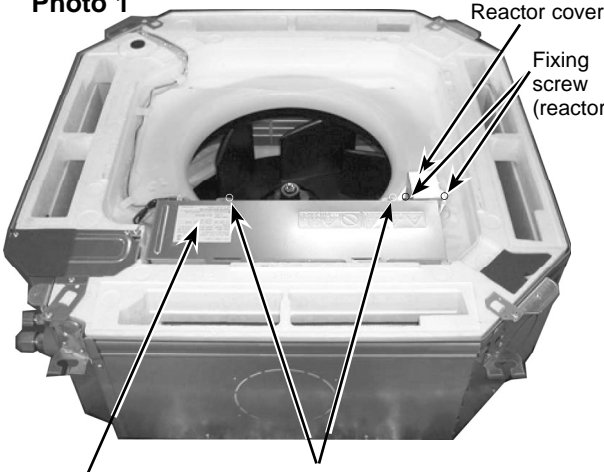
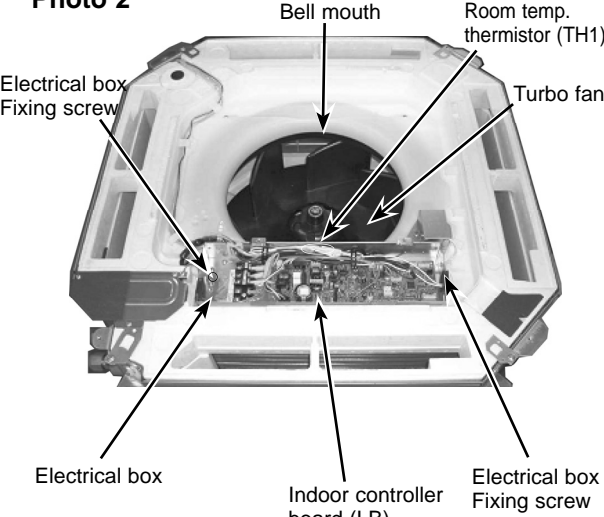
OPERATING PROCEDURE	PHOTOS & ILLUSTRATIONS
<p><b>1. Removing the air intake grille</b></p> <p>(1) Slide the knob of air intake grille toward the arrow ① to open the air intake grille.</p> <p>(2) Remove drop prevention hook from the panel.</p> <p>(3) Slide the shaft in the hinge to the direction of the arrow ② and remove the air intake grille.</p>	<p><b>Figure 1</b></p>  <p>Air intake grille          Air intake grille knob          Grille          Filter</p>
<p><b>2. Removing the room temperature thermistor (TH1)</b></p> <p>(1) Remove the air intake grille and the filter. (See Figure 1)</p> <p>(2) Remove the 2 screws from the electrical box.</p> <p>(3) Disconnect the connector CN20 (Red) from the indoor controller board.</p> <p>(4) Remove the room temperature thermistor and holder.</p>	<p><b>Photo 1</b></p>  <p>Reactor cover          Fixing screw (reactor)          Electrical box cover          Fixing screw (Electrical box)</p>
<p><b>3. Removing the reactor (DCL)</b></p> <p>(1) Remove the air intake grille and the filter. (See Figure 1)</p> <p>(2) Remove the 2 screws from the reactor cover.</p> <p>(3) Disconnect the relay connector of reactor.</p> <p>(4) Remove 2 reactor fixing screws and remove the reactor.</p>	<p><b>Photo 2</b></p>  <p>Bell mouth          Room temp. thermistor (TH1)          Turbo fan          Electrical box          Indoor controller board (I.B.)          Electrical box Fixing screw</p>
<p><b>4. Removing the indoor controller board (I.B)</b></p> <p>(1) Remove the air intake grille and the filter. (See Figure 1)</p> <p>(2) Remove the 2 screws from the electrical box cover.</p> <p>(3) Disconnect the connectors :</p> <ul style="list-style-type: none"> <li>CNMF (White/ 7P) for fan motor</li> <li>CN44 (White/ 4P) for thermistor (TH2/ TH5)</li> <li>CNP (Blue/ 3P) for drain pump</li> <li>CN4F (White/ 4P) for float switch</li> <li>CN01 (Black/ 5P) for earth and reactor</li> <li>CNV (White/ 20P) for vane motor</li> </ul> <p>(4) Remove the 6 supports from indoor controller board.</p> <p>(5) Remove the indoor controller board.</p>	
<p><b>5. Removing the electrical box</b></p> <p>(1) Remove the air intake grille and the filter. (See Figure 1)</p> <p>(2) Remove the 2 screws from the electrical box cover.</p> <p>(3) Disconnect the connectors. (Refer to procedure 4)</p> <p>(4) Remove 2 electrical box fixing screws and remove 2 hooks.</p> <p>(5) Pull the electrical box.</p> <p>&lt;Electrical parts in the electrical box&gt;</p> <ul style="list-style-type: none"> <li>Indoor controller board</li> <li>Terminal block (TB4)(TB5)</li> </ul>	



**OPERATING PROCEDURE**

**6. Removing the fan and fan motor (MF)**

- (1) Remove the electrical box. (See Photo 2)
- (2) Remove the bell mouth (3 screws). (See Photo 2)
- (3) Remove the turbo fan nut.
- (4) Pull out the turbo fan.
- (5) Remove the wire cover (3 screws).
- (6) Remove 2 wiring clamps.
- (7) Disconnect the connector of the fan motor (CNMF).
- (8) Remove the 3 nuts and washers and rubber mounts of the fan motor.

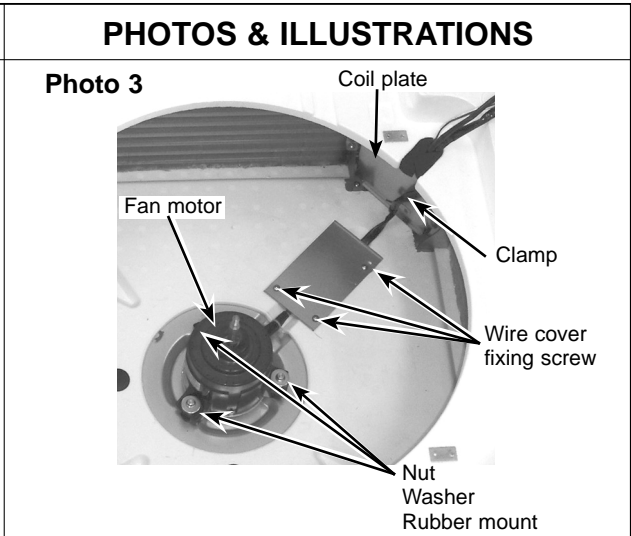

**7. Removing the panel**

- (1) Remove the air intake grille and the filter. (See Figure 1)
- (2) Disconnect the connector CNV (White/20P).

**Corner panel (See Figure 2)**

- (3) Remove the corner screw.
- (4) Slide the corner panel to the direction of the arrow ①, and remove the corner panel.

**Panel (See Photo 4, 5)**

- (5) Remove the 2 screws from the panel which fixes the oval holes.
- (6) Rotate the panel a little to come to the bell shaped hole where the screw is large and remove the panel.

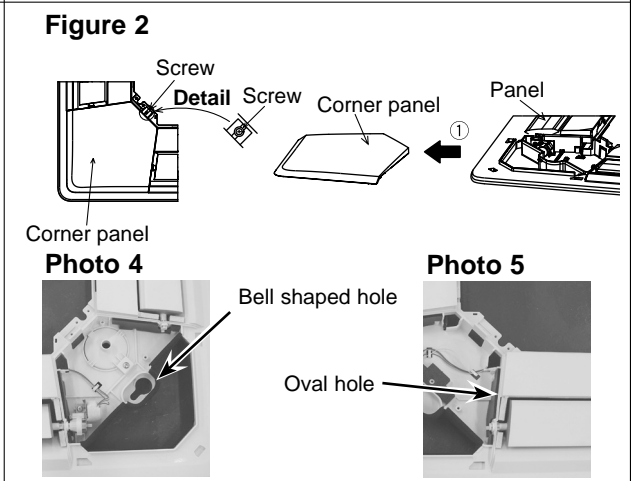

**8. Removing the drain pan**

- (1) Remove the air intake grille and the filter. (See Figure 1)
- (2) Remove the 2 screws from the electrical box cover.
- (3) Disconnect the connectors. (Refer to procedure 4)
- (4) Remove the panel. (See Photo 4, 5)
- (5) Remove the electrical wiring service panel (3 screws).
- (6) Remove the drain pump wire cover (1 screw).
- (7) Remove the electrical box. (See Photo 2)
- (8) Remove the bell mouth. (See Photo 2)
- (9) Remove the 4 screws and pull out the drain pan.

※ Pull out the left and right of the pan gradually.  
Be careful not to crack or damage the pan.

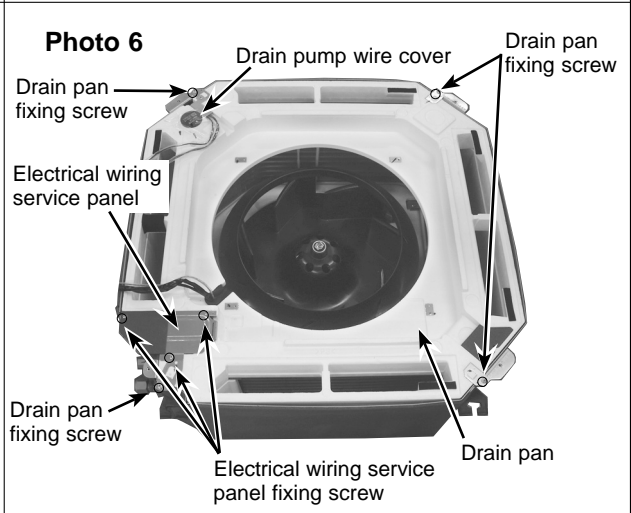

**9. Removing the pipe temperature thermistor (TH2) and condenser evaporator temperature thermistor (TH5)**

- (1) Remove the drain pan. (See Photo 6)
- (2) Remove the turbo fan. (See Photo 3)
- (3) Remove the 2 wiring clamps. (See Photo 3)
- (4) Remove the coil plate (2 screws).
- (5) Remove the thermistors which are inserted into the holders installed to the thin copper pipe.
- (6) Disconnect the 4-pin white connector (CN44).

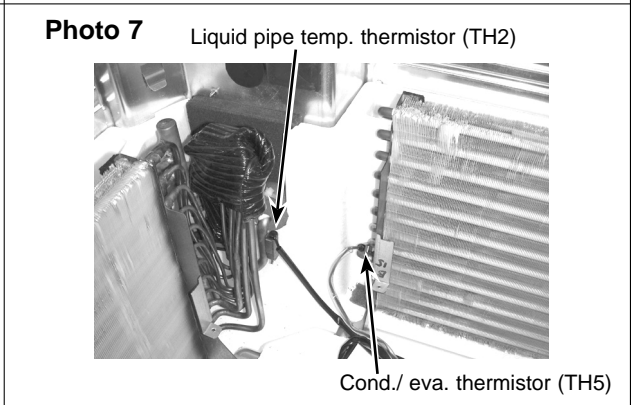

## OPERATING PROCEDURE

## PHOTOS & ILLUSTRATIONS

### 10 Removing the drain pump (DP) and float switch (FS)

- (1) Remove the drain pan. (See Photo 6)
- (2) Cut the hose band and remove the hose.
- (3) Remove the drain pump assembly (3 screws and 2 hooks).
- (4) Remove the drain pump (3 screws).
- (5) Remove the float switch (2 screws).

**Photo 8**

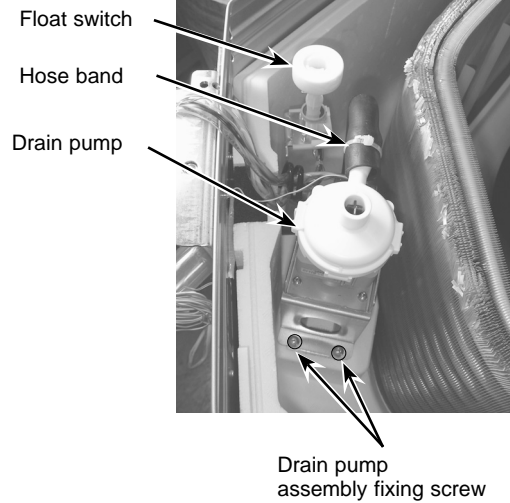

**Photo 9**

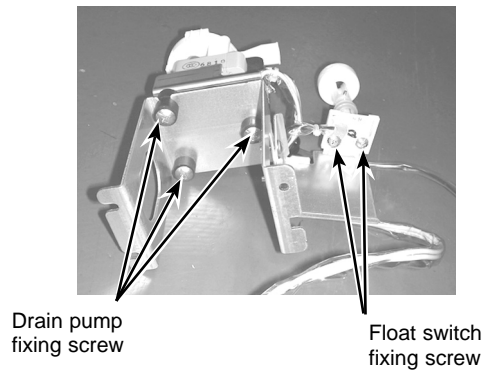

### 11. Removing the heat exchanger

- (1) Remove the drain pan. (See Photo 6)
- (2) Remove the 3 screws of the piping cover, and pull out piping cover.
- (3) Remove the 2 screws of coil plate.
- (4) Remove the 2 screws of the coil.
- (5) Remove the screw of the coil support.
- (6) Pull out the heat exchanger.

**Photo 10**

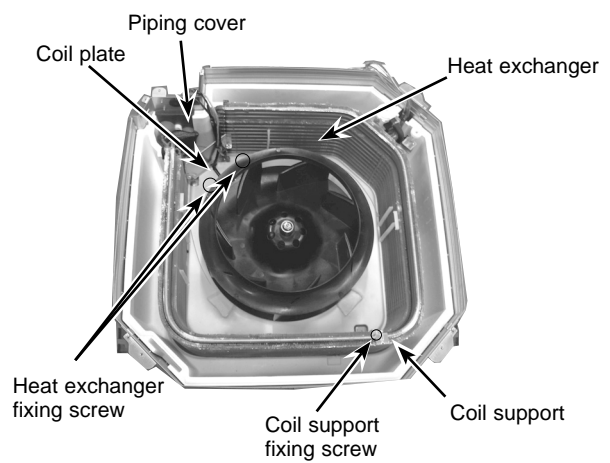

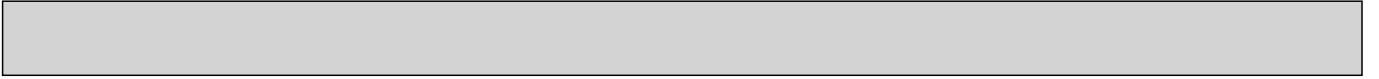

**Mr. SLIM™**

**mitsubishi electric corporation**

HEAD OFFICE : TOKYO BLDG., 2-7-3, MARUNOUCHI, CHIYODA-KU, TOKYO 100-8310, JAPAN

©Copyright 2007 MITSUBISHI ELECTRIC CORPORATION  
Distributed in Sep. 2012 No.OCH416 REVISED EDITION-D  
Distributed in Feb. 2012 No.OCH416 REVISED EDITION-C  
Distributed in Oct. 2009 No.OCH416 REVISED EDITION-B PDF 7  
Distributed in Nov. 2007 No.OCH416 REVISED EDITION-A PDF 8  
Distributed in Apr. 2007 No.OCH416 PDF 8  
Made in Japan

New publication, effective Sep. 2012  
Specifications are subject to change without notice.