

PARTS CATALOG

R410A

Outdoor unit

[model names]

[Service Ref.]

PUHZ-RP200YHA2

PUHZ-RP200YHA2

PUHZ-RP250YHA2

PUHZ-RP250YHA2

Note:

- This manual describes only service data of the outdoor units.
- RoHS compliant products have <G> mark on the spec name plate.

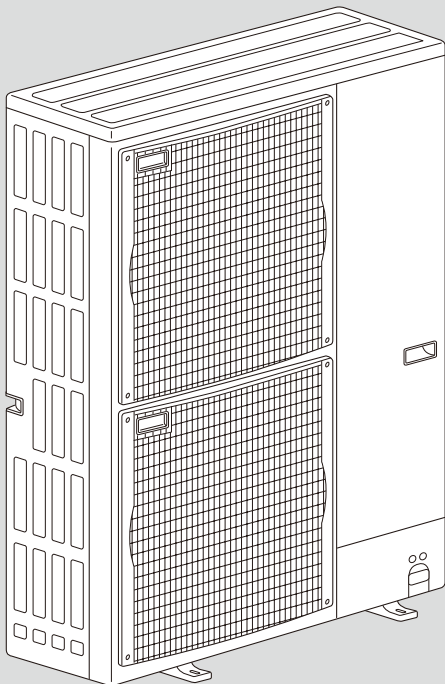

PUHZ-RP200YHA2
PUHZ-RP250YHA2

CONTENTS

1. RoHS PARTS LIST 2

SERVICE MANUAL (OCH428)

FUNCTIONAL AND ELECTRICAL PARTS
PUHZ-RP200YHA2

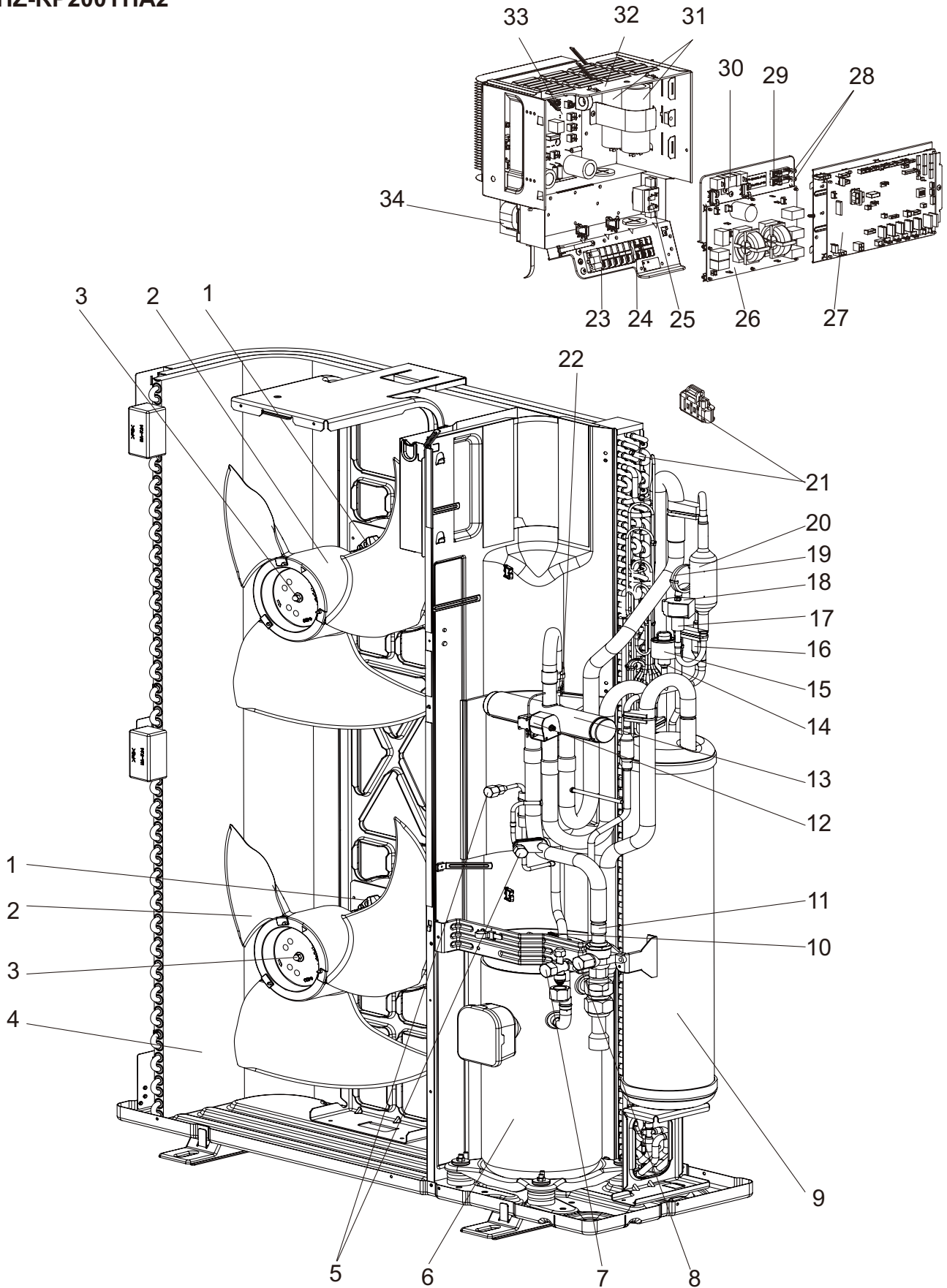

Part numbers that are circled are not shown in the figures.

No.	RoHS	Part No.	Part Name	Specification	Q'ty/set	Remarks (Drawing No.)	Wiring Diagram Symbol	Recom- mended Q'ty
					PUHZ-RP200YHA2			
1	G	R01 E46 221	FAN MOTOR		2		MF1,MF2	
2	G	R01 E06 115	PROPELLER FAN		2			
3	G	R01 E09 097	NUT	M6	2			
4	G	R01 H07 408	HEAT EXCHANGER		1			
5	G	R01 E24 413	CHARGE PLUG		2			
6	G	T97 415 756	COMPRESSOR	ANB52FFJMT	1	With RUBBER MOUNTS	MC	
7	G	R01 E13 410	STOP VALVE 3/8		1			
8	G	R01 E13 411	BALL VALVE 3/4		1			
9	G	R01 E50 440	ACCUMULATOR		1			
10	G	R01 E14 201	THERMISTOR (DISCHARGE)		1		TH4	
11	G	R01 45L 450	STRAINER		1			
12	G	T7W E39 242	SOLENOID COIL		1		21S4	
13	G	R01 E12 403	4-WAY VALVE		1			
14	G	R01 H19 401	LEV		1			
15	G	R01 E50 242	LEV COIL		1		LEV-A	
16	G	R01 E03 418	RESTRICTOR VALVE		1			
17	G	R01 E13 428	BAYPASS VALVE		1			
18	G	T7W E40 242	BAYPASS VALVE COIL		1		SV	
19	G	R01 E31 425	CAPILLARY TUBE	$\phi 4.0 \times \phi 3.0 \times 500$	1			
20	G	—	REPLACE FILTER		1	(BK00C119G02)		
21	G	R01 N00 202	THERMISTOR(2-PHASE PIPE, OUTDOOR)		1		TH6,7	
22	G	T7W E06 208	HIGH PRESSURE SWITCH		1		63H	
23	G	T7W E30 716	TERMINAL BLOCK	5P(L1, L2, L3, N, \ominus)	1		TB1	
24	G	R01 E19 246	TERMINAL BLOCK	3P(S1, S2, S3)	1		TB2	
25	G	T7W E16 259	REACTOR		1		ACL4	
26	G	T7W E24 346	NOISE FILTER		1		N.F.	
27	G	T7W E63 315	CONTROLLER BOARD		1		C.B.	
28	G	R01 30L 241	FUSE HOLDER		2			
29	G	R01 E07 239	FUSE	250V 15A	2		FUSE1, 2	
30	G	R01 E10 233	RESISTOR		1		RS	
31	G	T7W E21 255	MAIN SMOOTHING CAPACITOR		2		CB1,2	
32	G	—	ELECTRICAL PARTS BOX		1	(BK00B702G04)		
33	G	T7W E44 313	POWER BOARD		1		P.B.	
34	G	T7W E13 259	REACTOR		1		DCL	
35	G	R01 E96 202	THERMISTOR (OUTDOOR PIPE)		1		TH3	
36	G	R01 E06 239	FUSE	250V 6.3A	2		F3,4	
37	G	R01 E10 467	MUFFLER		1			

**FUNCTIONAL AND ELECTRICAL PARTS
PUHZ-RP250YHA2**

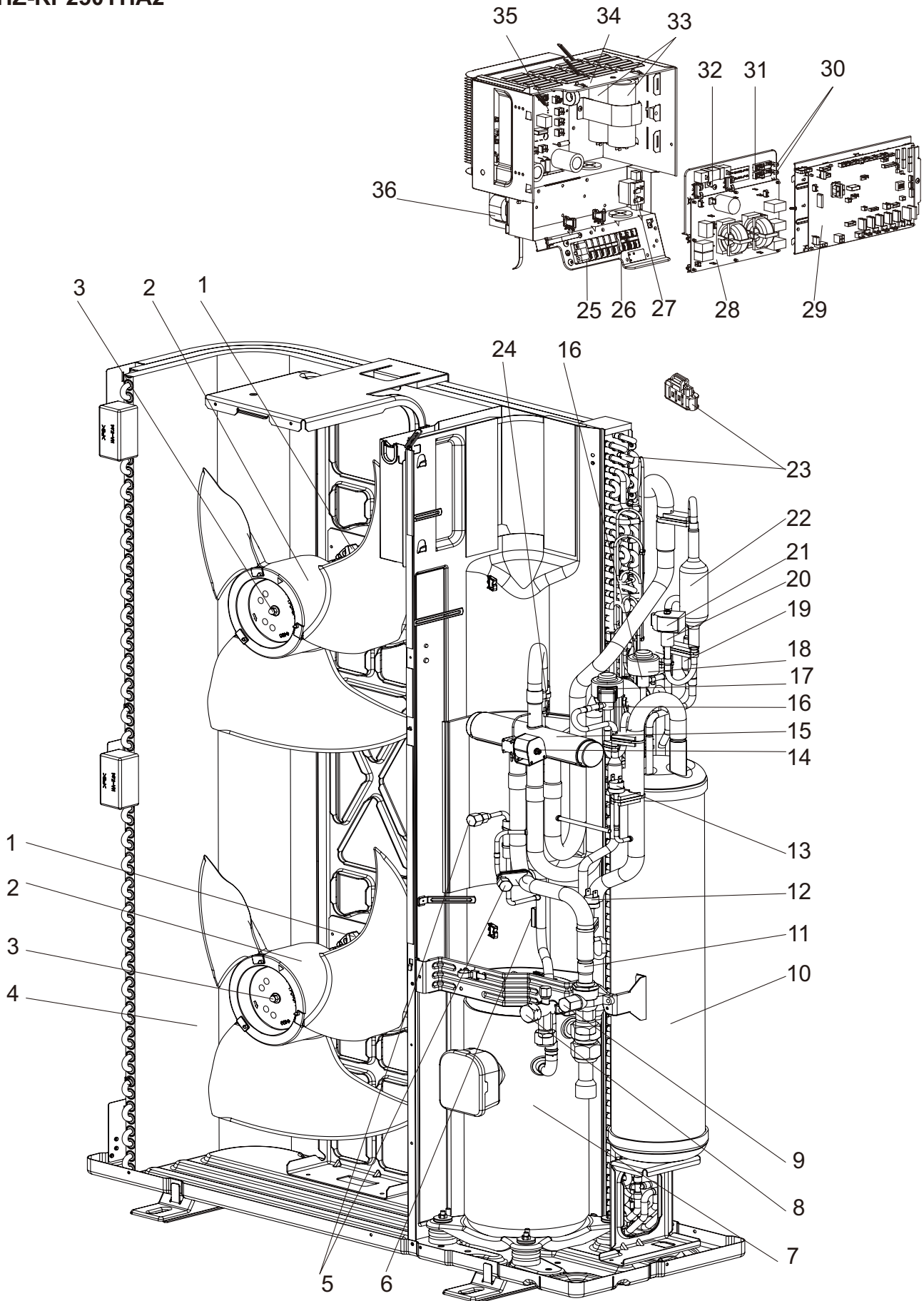

Part numbers that are circled are not shown in the figures.

No.	RoHS	Part No.			Part Name	Specification	Q'ty/set	Remarks (Drawing No.)	Wiring Diagram Symbol	Recom- mended Q'ty
							PUHZ-RP250YHA2			
1	G	R01	E46	221	FAN MOTOR		2		MF1,MF2	
2	G	R01	E06	115	PROPELLER FAN		2			
3	G	R01	E09	097	NUT	M6	2			
4	G	R01	H07	408	HEAT EXCHANGER		1			
5	G	R01	E24	413	CHARGE PLUG		2			
6	G	R01	E14	201	THERMISTOR (DISCHARGE)		1		TH4	
7	G	T97	415	756	COMPRESSOR	ANB52FFJMT	1	With RUBBER MOUNTS	MC	
8	G	R01	E23	410	STOP VALVE 1/2		1			
9	G	R01	E13	411	BALL VALVE 3/4		1			
10	G	T7W	E16	440	POWER RECEIVER		1			
11	G	R01	45L	450	STRAINER		1			
12	G	T7W	E06	208	HIGH PRESSURE SWITCH	OFF 3.6MPa	1		63H2	
13	G	R01	E00	209	LOW PRESSURE SWITCH		1		63L	
14	G	T7W	E39	242	SOLENOID COIL		1		21S4	
15	G	R01	E12	403	4-WAY VALVE		1			
16	G	T7W	E24	401	LEV		2			
17	G	T7W	E45	242	LEV COIL		1		LEV-B	
18	G	T7W	E44	242	LEV COIL		1		LEV-A	
19	G	R01	E03	418	RESTRICTOR VALVE		1			
20	G	R01	E13	428	BAYPASS VALVE		1			
21	G	T7W	E40	242	BAYPASS VALVE COIL		1		SV	
22	G		—		REPLACE FILTER		1	(BK00C119G02)		
23	G	R01	N00	202	THERMISTOR(2-PHASE PIPE, OUTDOOR)		1		TH6,7	
24	G	R01	E06	208	HIGH PRESSURE SWITCH	OFF 4.15MPa	1		63H1	
25	G	T7W	E30	716	TERMINAL BLOCK	5P(L1, L2 ,L3 ,N , ⊕)	1		TB1	
26	G	R01	E19	246	TERMINAL BLOCK	3P(S1,S2,S3)	1		TB2	
27	G	T7W	E16	259	REACTOR		1		ACL4	
28	G	T7W	E24	346	NOISE FILTER		1		N.F.	
29	G	T7W	E64	315	CONTROLLER BOARD		1		C.B.	
30	G	R01	30L	241	FUSE HOLDER		2			
31	G	R01	E07	239	FUSE	250V 15A	2		FUSE1, 2	
32	G	R01	E10	233	RESISTOR		1		RS	
33	G	T7W	E21	255	MAIN SMOOTHING CAPACITOR		2		CB1,2	
34	G		—		ELECTRICAL PARTS BOX		1	(BK00B702G04)		
35	G	T7W	E44	313	POWER BOARD		1		P.B.	
36	G	T7W	E13	259	REACTOR		1		DCL	
37	G	R01	E96	202	THERMISTOR (OUTDOOR PIPE)		1		TH3	
38	G	R01	E06	239	FUSE	250V 6.3A	2		F3,4	
39	G	R01	E10	467	MUFFLER		1			

STRUCTURAL PARTS
PUHZ-RP200YHA2
PUHZ-RP250YHA2

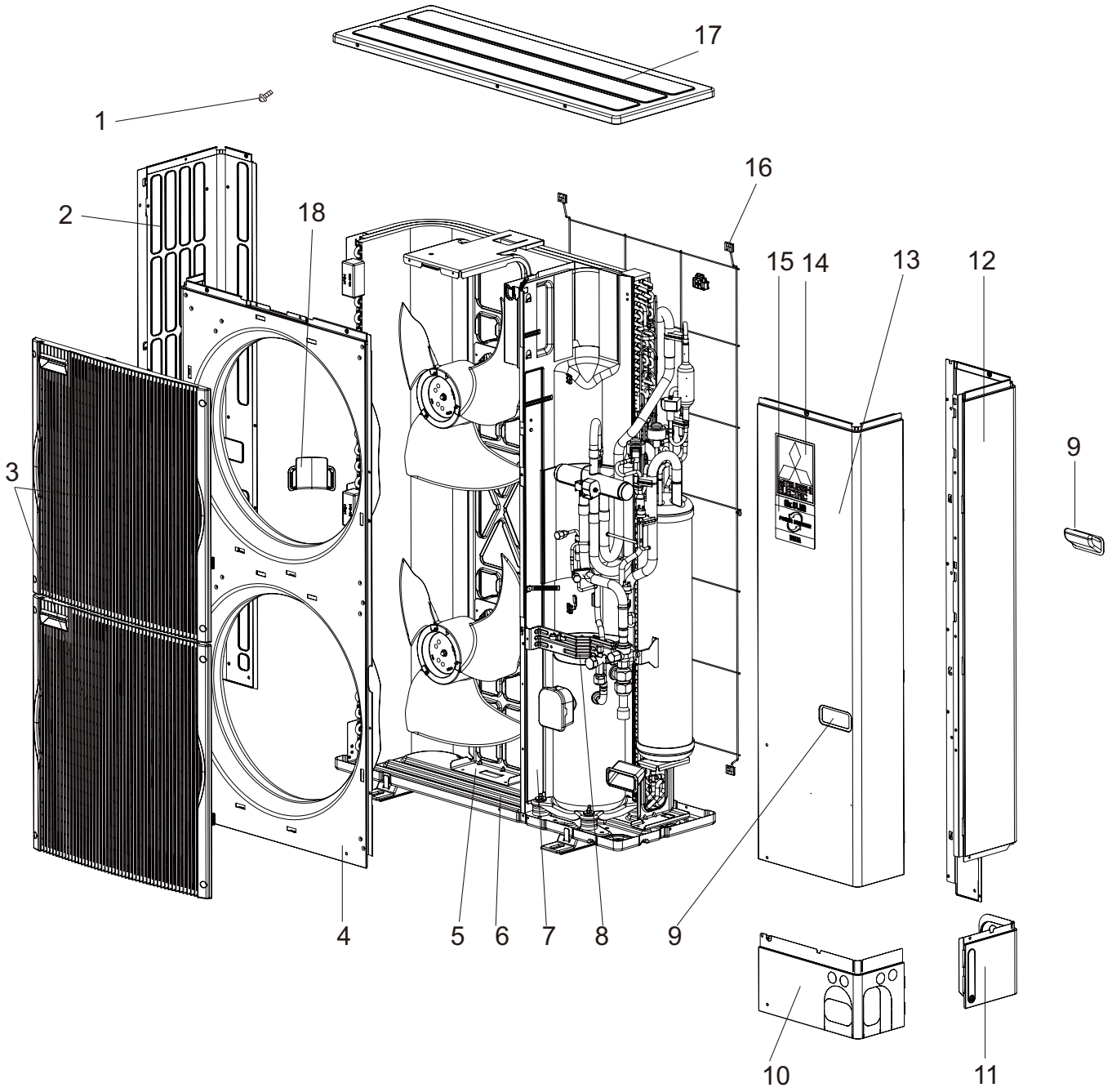



No.	RoHS	Part No.	Part Name	Specification	Q'ty/set		Remarks (Drawing No.)	Wiring Diagram Symbol	Recom- mended Q'ty
					PUHZ-RP-YHA2				
					200	250			
1	G	—	F.ST SCREW	(5X10)	38	38	(DG12F536H10)		
2	G	R01 E15 662	SIDE PANEL (L)		1	1			
3	G	T7W E03 691	FAN GRILLE		2	2			
4	G	T7W E06 667	FRONT PANEL		1	1			
5	G	R01 E39 130	MOTOR SUPPORT		1	1			
6	G	R01 E36 686	BASE ASSY		1	1			
7	G	—	SEPARATOR		1	1	(BK00C374GC0)		
8	G	—	VALVE BED ASSY		1	1	(BK00C375G03)		
9	G	R01 E01 655	HANDLE		2	2			
10	G	R01 E13 658	COVER PANEL (FRONT)		1	1			
11	G	R01 E11 658	COVER PANEL (REAR)		1	1			
12	G	T7W E20 661	SIDE PANEL(R)		1	1			
13	G	T7W E07 667	SERVICE PANEL		1	1			
14	G	—	LABEL (MITSUBISHI)		1	1	(DG79R130H01)		
15	G	—	LABEL (INVERTER)		1	1	(BK79C208G02)		
16	G	R01 E07 698	REAR GUARD		1	1			
17	G	R01 E15 641	TOP PANEL		1	1			
18	G	R01 E02 655	HANDLE		1	1			

Mr. SLIM™

 **mitsubishi electric corporation**

HEAD OFFICE : TOKYO BLDG., 2-7-3, MARUNOUCHI, CHIYODA-KU, TOKYO 100-8310, JAPAN