

mitsubishi electric

Air-Conditioners ROOFTOP UNIT

CE

PRH-P200, 250MYA

**FOR INSTALLER
FÜR INSTALLATEUR
POUR L'INSTALLATEUR
PARA EL INSTALADOR**

**PER L'INSTALLATORE
VOOR DE INSTALLATEUR
FÖR INSTALLATÖREN
PARA O INSTALADOR**

GB

D

F

E

INSTALLATION MANUAL

For safe and correct use, please read this operation manual thoroughly before operating the air-conditioner unit.

INSTALLATIONSHANDBUCH

Zum sicheren und ordnungsgemäßen Gebrauch der Klimageräte das Installationshandbuch gründlich durchlesen.

MANUEL D'INSTALLATION

Veillez lire le manuel d'installation en entier avant d'installer ce climatiseur pour éviter tout accident et vous assurer d'une utilisation correcte.

MANUAL DE INSTALACIÓN

Para un uso seguro y correcto, lea detalladamente este manual de instalación antes de montar la unidad de aire acondicionado.

MANUALE DI INSTALLAZIONE

Per un uso sicuro e corretto, leggere attentamente questo manuale di installazione prima di installare il condizionatore d'aria.

INSTALLATIEHANDLEIDING

Voor een veilig en juist gebruik moet u deze installatiehandleiding grondig doorlezen voordat u de airconditioner installeert.

INSTALLATIONSMANUAL

Läs denna installationsmanual noga för säkert och korrekt bruk innan luftkonditioneringen installeras.

MANUAL DE INSTALAÇÃO

Para segurança e utilização correctas, leia atentamente este manual de instalação antes de instalar a unidade de ar condicionado.

I

NL

SW

P

3

[Fig. 3.1.1]

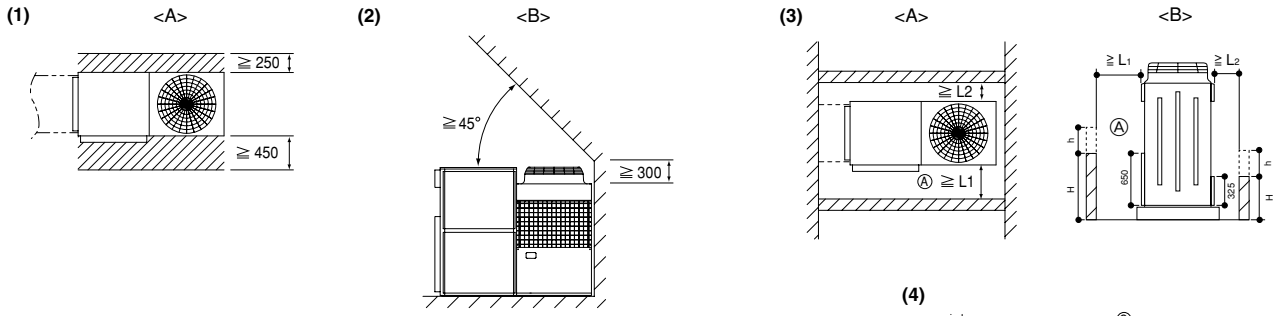

4

[Fig. 4.0.1]

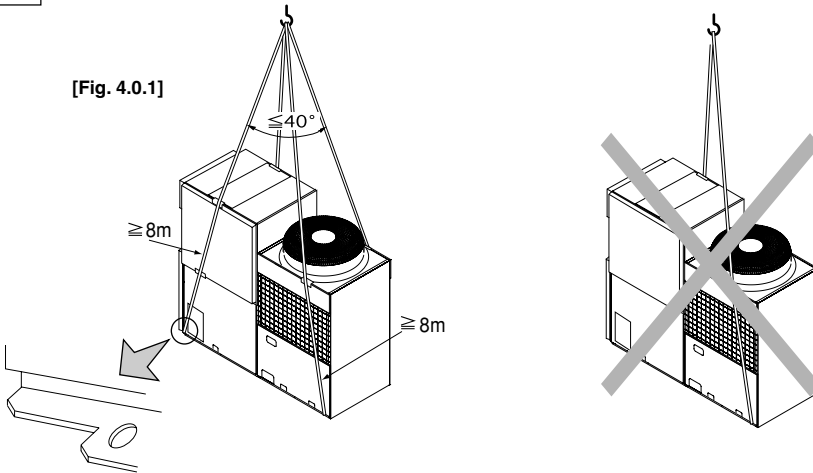

(4)

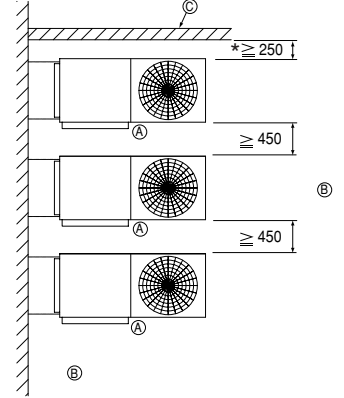

<A> Top view
 Side view
 Ⓐ Front
 Ⓑ Must be open
 Ⓒ Wall height (H)
 L1: 450 L2: 250

5

[Fig. 5.1.1]

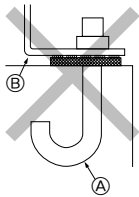

Ⓐ M10 anchor bolt procured at the site.
 Ⓑ Corner is not seated.

[Fig. 5.1.2]

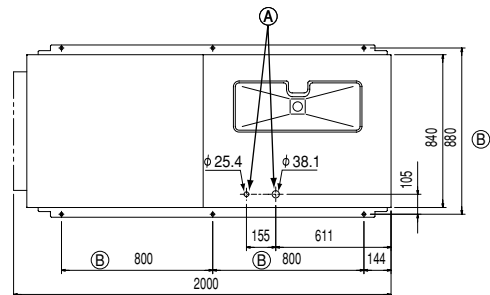

Ⓐ Bottom wiring through hole
 Ⓑ (bolt hole)

6

[Fig.6.0.1]

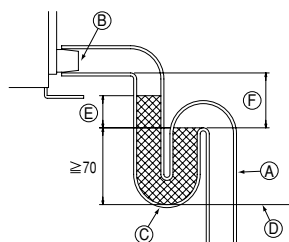
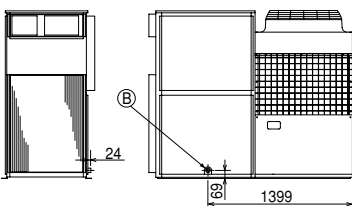

Ⓐ Drain piping
 Ⓑ Socket R1
 Ⓒ Drain trap
 Ⓓ The drain pipe should extend below the level.
 Ⓔ $\geq 2 \times$ External static pressure
 Ⓕ $\geq 2 \times$ Ⓔ

[Fig.7.0.1]

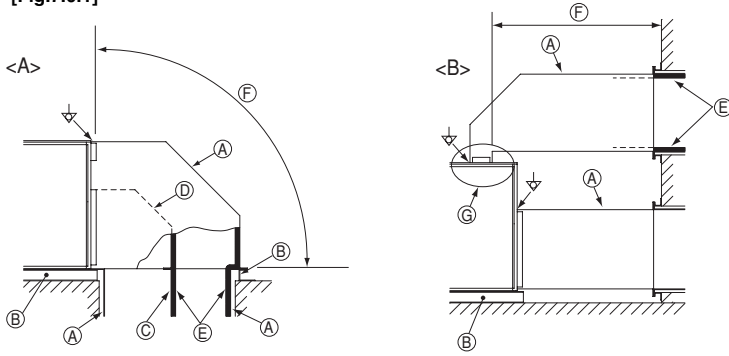

- <A> Ex. Side flow
- Ex. Top flow
- Ⓐ Duct
- Ⓑ Roof curb
- Ⓒ Single duct divider
- Ⓓ Plenum divider
- Ⓔ Insulator
- Ⓕ Keep duct-work length 850 or more
- Ⓖ Rainproof the part where the duct flange is screwed on (Top flow only).

[Fig.7.0.2]

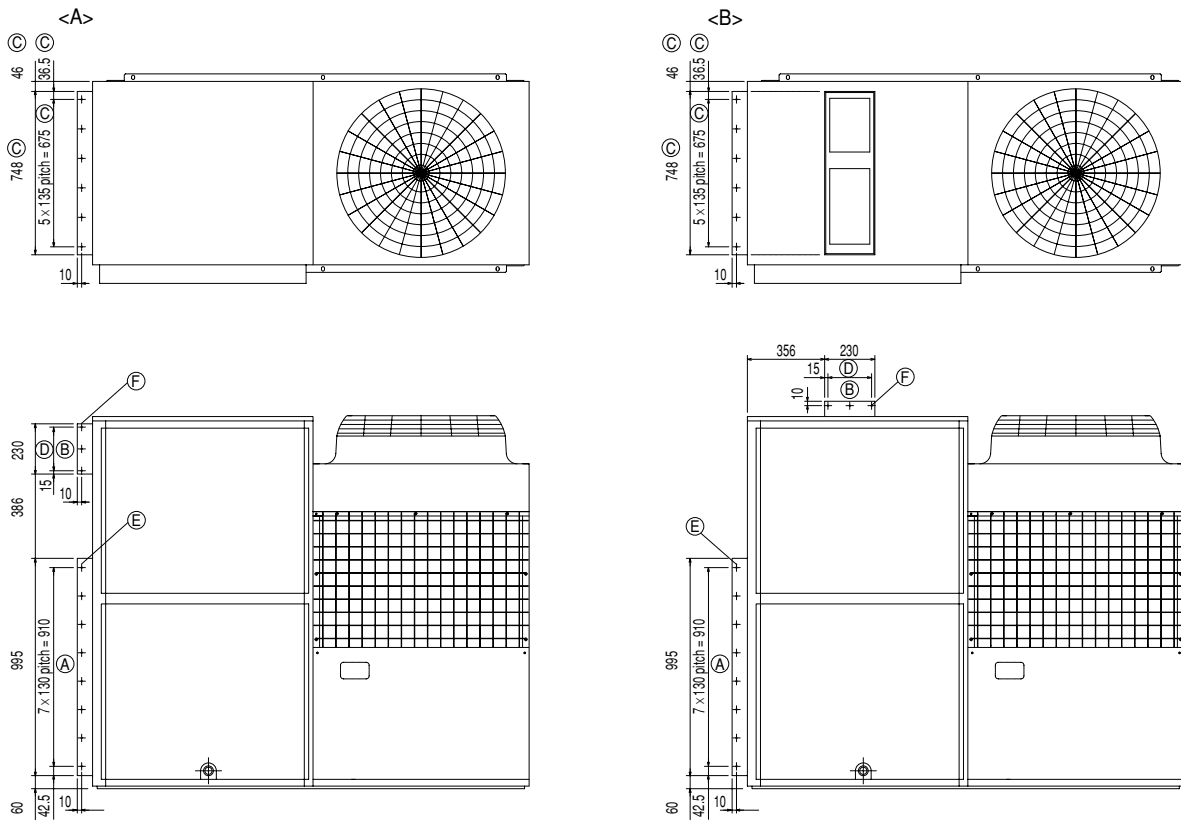

- <A> In case of side flow
- In case of top flow
- Ⓐ Inlet duct flange
- Ⓑ Outlet duct flange
- Ⓒ Same as inlet and outlet duct flange
- Ⓓ 2 × 100 pitch = 200
- Ⓔ 28 - ø3 holes (Inlet duct mount holes)
- Ⓕ 18 - ø3 holes (Outlet duct mount holes)

7.1

[Fig.7.1.1]

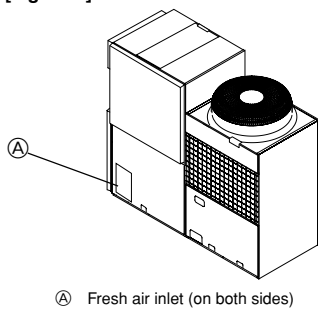

[Fig.7.1.2]

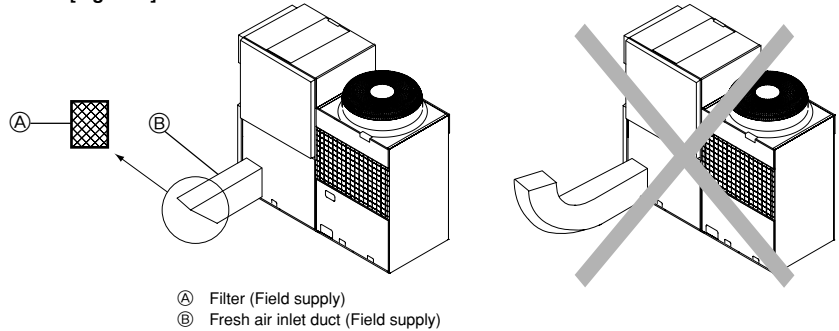

Ⓐ Fresh air inlet (on both sides)

Ⓐ Filter (Field supply)
Ⓑ Fresh air inlet duct (Field supply)

8

8.1

[Fig.8.1.1]

(1)

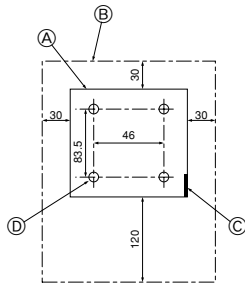

- (A) Remote controller profile
- (B) Required clearances surrounding the remote controller
- (C) Temperature sensor
- (D) Installation pitch

(2)

<A> For installation in the switch box:

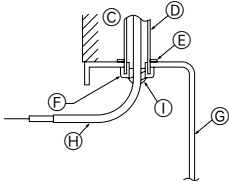

- (C) Wall
- (D) Conduit
- (E) Lock nut
- (F) Bushing
- (G) Switch box
- (H) Remote controller cord
- (I) Seal with putty.

 For direct installation on the wall select one of the following:

B-1.

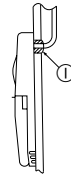

B-2.

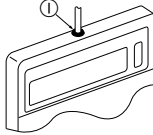

(3)

<A> For installation in the switch box

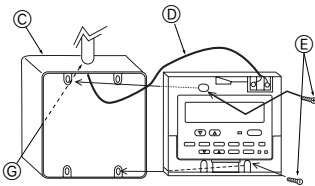

- (C) Switch box for two pieces
- (D) Remote controller cord
- (E) Cross-recessed, pan-head screw
- (G) Seal the remote controller cord service entrance with putty
- (H) Wood screw

 For direct installation on the wall

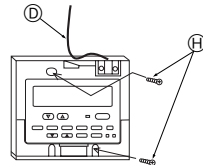

8.2

[Fig.8.2.1]

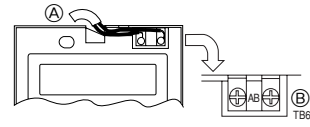

- (A) To TB5 on the unit
- (B) Terminal block TB6 in remote controller
No polarity

8.3

[Fig.8.3.1]

(1)

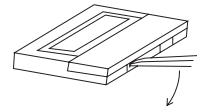

(2)

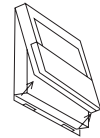

[Fig.8.3.2]

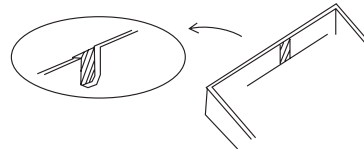

9

[Fig. 9.0.1]

(1) Normal Connecting

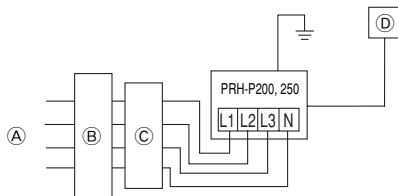

(2) Grouping (16 units)

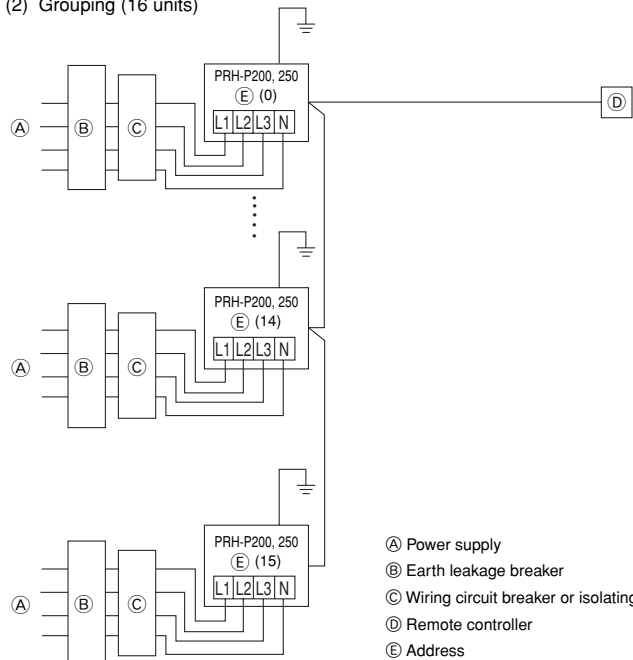

- (A) Power supply
- (B) Earth leakage breaker
- (C) Wiring circuit breaker or isolating switch
- (D) Remote controller
- (E) Address

[Fig. 9.1.1]

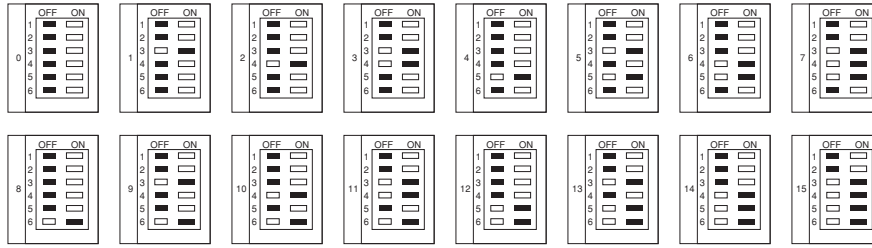

9.2

[Fig. 9.2.1]

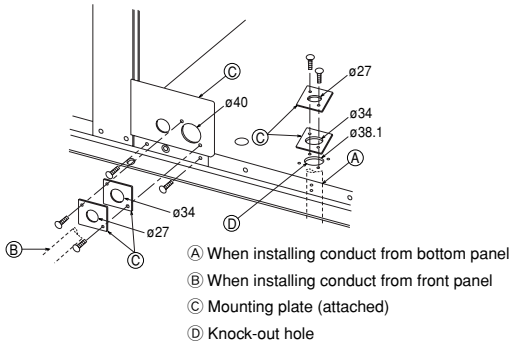

10

[Fig. 10.0.1]

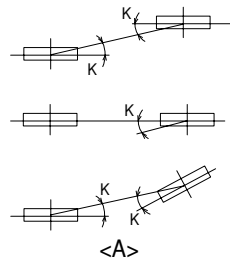

[Fig. 10.0.2]

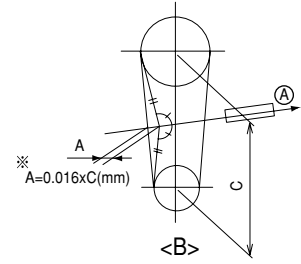

- <A> Parallel degree of pulley
- Belt tension
- Ⓐ Flexion load (W)

11

[Fig. 11.0.1]

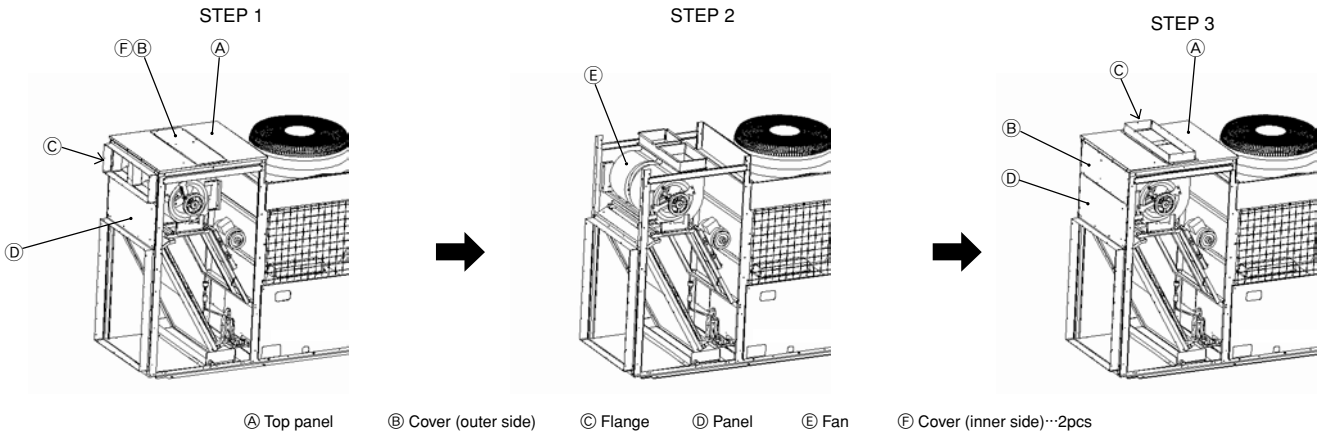

12

12.2

[Fig.12.2.1]

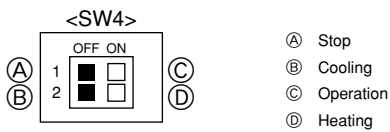

14

[Fig.14.1.1]

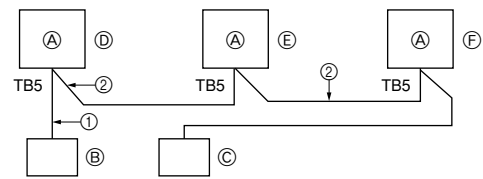

- Ⓐ Unit
- Ⓑ Main remote controller
- Ⓒ Subordinate remote controller
- Ⓓ Refrigerant address = 00
- Ⓔ Refrigerant address = 01
- Ⓕ Refrigerant address = 02

Contents

1. Safety precautions	6	8.3. Fitting the upper case	9
1.1. Before installation and electric work	6	8.4. Function selection	10
1.2. Precautions for devices that use R407C refrigerant	6	9. Electrical wiring	13
1.3. Before getting installed	7	9.1. Address settings	14
1.4. Before getting installed (moved) - electrical work	7	9.2. Wiring connection	14
1.5. Before starting the test run	7	10. Specifications for installing the belt	14
2. Unit accessories	7	11. Modification method of fan direction (From side flow to top flow)	14
3. Selecting an installation site	7	12. Test run	15
3.1. Space required around unit	7	12.1. Before test run	15
4. Lifting method and weight of product	8	12.2. Test run procedures	15
5. Installation of unit	8	12.3. Self-check	16
5.1. Installation	8	12.4. Remote controller check	17
6. Drain piping work	8	13. Troubleshooting	17
7. Duct work	8	13.1. How to handle problems with the test run	17
7.1. Fresh air inlet, duct installations, and operating restrictions	9	13.2. The following occurrences are not problems or errors	18
8. Remote controller	9	14. System control	19
8.1. Installing procedures	9	14.1. System settings	19
8.2. Connecting procedures	9	14.2. Examples of refrigerant system address setting	19

1. Safety precautions

1.1. Before installation and electric work

- ▶ Before installing the unit, make sure you read all the “Safety precautions”.
- ▶ The “Safety precautions” provide very important points regarding safety. Make sure you follow them.

Symbols used in the text

⚠ Warning:

Describes precautions that should be observed to prevent danger of injury or death to the user.

⚠ Caution:

Describes precautions that should be observed to prevent damage to the unit.

Symbols put on the unit

- ⊘ : Indicates an action that must be avoided.
- ❗ : Indicates that important instructions must be followed.
- ⚡ : Indicates a part which must be grounded.
- ⚠ : Indicates that caution should be taken with rotating parts. (This symbol is displayed on the main unit label.) <Color: yellow>
- ⚠ : Beware of electric shock. (This symbol is displayed on the main unit label.) <Color: yellow>

⚠ Warning:

Carefully read the labels affixed to the main unit.

⚠ Warning:

- Ask the dealer or an authorized technician to install the air conditioner.
 - Improper installation by the user may result in water leakage, electric shock, or fire.
- Install the unit at a place that can withstand its weight.
 - Inadequate strength may cause the unit to fall down, resulting in injuries.
- Use the specified cables for wiring. Make the connections securely so that the outside force of the cable is not applied to the terminals.
 - Inadequate connection and fastening may generate heat and cause a fire.
- Prepare for strong winds and earthquakes and install the unit at the specified place.
 - Improper installation may cause the unit to topple and result in injury.
- Always use other accessories specified by Mitsubishi Electric.
 - Ask an authorized technician to install the accessories. Improper installation by the user may result in water leakage, electric shock, or fire.
- Never repair the unit. If the air conditioner must be repaired, consult the dealer.
 - If the unit is repaired improperly, water leakage, electric shock, or fire may result.
- Do not touch the heat exchanger fins.
 - Improper handling may result in injury.
- When handling this product, always wear protective equipment.
EG: Gloves, full arm protection namely boiler suit, and safety glasses.
 - Improper handling may result in injury.
- Install the air conditioner according to this Installation Manual.
 - If the unit is installed improperly, water leakage, electric shock, or fire may result.

- Have all electric work done by a licensed electrician according to “Electric Facility Engineering Standard” and “Interior Wire Regulations” and the instructions given in this manual and always use a special circuit.
 - If the power source capacity is inadequate or electric work is performed improperly, electric shock and fire may result.
- Securely install the unit terminal cover (panel).
 - If the terminal cover (panel) is not installed properly, dust or water may enter the unit and fire or electric shock may result.
- When re-charging the refrigerant circuit after installation or relocation of the unit, only use the specified refrigerant (R407).
 - If a different refrigerant or air is mixed with the original refrigerant, the refrigerant cycle may malfunction and the unit may be damaged.
- When moving and reinstalling the air conditioner, consult the dealer or an authorized technician.
 - If the air conditioner is installed improperly, water leakage, electric shock, or fire may result.
- Do not reconstruct or change the settings of the protection devices.
 - If the pressure switch, thermal switch, or other protection device is shorted and operated forcibly, or parts other than those specified by Mitsubishi Electric are used, fire or explosion may result.
- To dispose of this product, consult your dealer.
- The installer and system specialist shall secure safety against leakage according to local regulation or standards.
 - Following standards may be applicable if local regulation are not available.
- Pay a special attention to the place, such as a basement, etc. where refrigeration gas can stay, since refrigeration is heavier than the air.
- The appliance is not intended for use by young children or infirm persons without supervision.
- Young children should be supervised to ensure that they do not play with the appliance.

1.2. Precautions for devices that use R407C refrigerant

⚠ Caution:

- Use liquid refrigerant to fill the system.
 - If gas refrigerant is used to seal the system, the composition of the refrigerant in the cylinder will change and performance may drop.
- Do not use a refrigerant other than R407C.
 - If another refrigerant (R22, etc.) is used, the chlorine in the refrigerant may cause the refrigerator oil to deteriorate.
- Use a vacuum pump with a reverse flow check valve.
 - The vacuum pump oil may flow back into the refrigerant cycle and cause the refrigerator oil to deteriorate.
- Do not use the following tools that are used with conventional refrigerants.
(Gauge manifold, charge hose, gas leak detector, reverse flow check valve, refrigerant charge base, refrigerant recovery equipment)
 - If the conventional refrigerant and refrigerator oil are mixed in the R407C, the refrigerant may deteriorate.
 - If water is mixed in the R407C, the refrigerator oil may deteriorate.
 - Since R407C does not contain any chlorine, gas leak detectors for conventional refrigerants will not react to it.
- Do not use a charging cylinder.
 - Using a charging cylinder may cause the refrigerant to deteriorate.
- Be especially careful when managing the tools.
 - If dust, dirt, or water gets in the refrigerant cycle, the refrigerant may deteriorate.

1.3. Before getting installed

⚠ Caution:

- **Do not install the unit where combustible gas may leak.**
 - If the gas leaks and accumulates around the unit, an explosion may result.
- **Do not use the air conditioner where food, pets, plants, precision instruments, or artwork are kept.**
 - The quality of the food, etc. may deteriorate.
- **Do not use the air conditioner in special environments.**
 - Oil, steam, sulfuric smoke, etc. can significantly reduce the performance of the air conditioner or damage its parts.
- **When installing the unit in a hospital, communication station, or similar place, provide sufficient protection against noise.**
 - The inverter equipment, private power generator, high-frequency medical equipment, or radio communication equipment may cause the air conditioner to operate erroneously, or fail to operate. On the other hand, the air conditioner may affect such equipment by creating noise that disturbs medical treatment or image broadcasting.
- **Do not install the unit on a structure that may cause leakage.**
 - When the room humidity exceeds 80 % or when the drain pipe is clogged, condensation may drip from the indoor unit. Perform collective drainage work together with the outdoor unit, as required.

1.4. Before getting installed (moved) - electrical work

⚠ Caution:

- **Ground the unit.**
 - Do not connect the ground wire to gas or water pipes, lightning rods, or telephone ground lines. Improper grounding may result in electric shock.
- **The reverse phase of L lines (L1, L2, L3) can be detected (Error cord: 4103), but the reverse phase of L lines and N line can be not be detected.**
 - The some electric parts should be damaged when power is supplied under the miss wiring.
- **Install the power cable so that tension is not applied to the cable.**
 - Tension may cause the cable to break and generate heat and cause a fire.
- **Install an earth leakage circuit breaker, as required.**
 - If an earth leakage circuit breaker is not installed, electric shock may result.
- **Use power line cables of sufficient current carrying capacity and rating.**
 - Cables that are too small may leak, generate heat, and cause a fire.
- **Use only a circuit breaker and fuse of the specified capacity.**
 - A fuse or circuit breaker of a larger capacity or a steel or copper wire may result in a general unit failure or fire.

2. Unit accessories

- ① Conduit mounting plate × 3 ② Tapping screw M4 × 4 ③ Remote controller

3. Selecting an installation site

- Select a site with sturdy fixed surface sufficiently durable against the weight of unit.
- Before installing unit, the routing to carry in unit to the installation site should be determined.
- Select a site where the unit is not affected by entering air.
- Select a site where the flow of supply and return air is not blocked.
- Select a site which allows the supply air to be distributed fully in room.
- Do not install unit at a site with oil splashing or steam in much quantity.
- Do not install unit at a site where combustible gas may generate, flow in, stagnate or leak.
- Do not install unit at a site where equipment generating high frequency waves (a high frequency wave welder for example) is provided.
- Do not install unit at a site where fire detector is located at the supply air side. (Fire detector may operate erroneously due to the heated air supplied during heating operation.)
- When special chemical product may scatter around such as site chemical plants and hospitals, full investigation is required before installing unit. (The plastic components may be damaged depending on the chemical product applied.)

3.1. Space required around unit

[Fig. 3.1.1] (P.2)

- <A> Top view Side view
Ⓐ Front Ⓑ Must be open
Ⓒ Wall height (H)
L1: 450 L2: 250

- **Do not wash the air conditioner units.**
 - Washing them may cause an electric shock.
- **Be careful that the installation base is not damaged by long use.**
 - If the damage is left uncorrected, the unit may fall and cause personal injury or property damage.
- **Install the drain piping according to this Installation Manual to ensure proper drainage. Wrap thermal insulation around the pipes to prevent condensation.**
 - Improper drain piping may cause water leakage and damage to furniture and other possessions.
- **Be very careful about product transportation.**
 - Only one person should not carry the product if it weighs more than 20 kg.
 - Some products use PP bands for packaging. Do not use any PP bands for a means of transportation. It is dangerous.
 - Do not touch the heat exchanger fins. Doing so may cut your fingers.
 - When transporting the outdoor unit, suspend it at the specified positions on the unit base. Also support the outdoor unit at four points so that it cannot slip sideways.
- **Safely dispose of the packing materials.**
 - Packing materials, such as nails and other metal or wooden parts, may cause stabs or other injuries.
 - Tear apart and throw away plastic packaging bags so that children will not play with them. If children play with a plastic bag which was not torn apart, they face the risk of suffocation.

1.5. Before starting the test run

⚠ Caution:

- **Turn on the power at least 12 hours before starting operation.**
 - Starting operation immediately after turning on the main power switch can result in severe damage to internal parts. Keep the power switch turned on during the operational season.
- **Do not touch the switches with wet fingers.**
 - Touching a switch with wet fingers can cause electric shock.
- **Do not touch the refrigerant pipes during and immediately after operation.**
 - During and immediately after operation, the refrigerant pipes are may be hot and may be cold, depending on the condition of the refrigerant flowing through the refrigerant piping, compressor, and other refrigerant cycle parts. Your hands may suffer burns or frostbite if you touch the refrigerant pipes.
- **Do not operate the air conditioner with the panels and guards removed.**
 - Rotating, hot, or high-voltage parts can cause injuries.

(1) Basic space required

A space of at least 250 mm is necessary at the back for inlet air. Taking servicing, etc. from the rear into account, a space of about 450 mm should be provided, the same as at the front.

(2) When there is an obstruction above the unit

(3) When unit is surrounded by walls

Note:

- **Wall heights (H) of the front and the back sides shall be within overall height of unit.**
- **If the panel height is exceeded, add the "h" dimension of the Fig. 3.1.1 to L1 and L2.**

L1: 450 L2: 250

Example: When h is 100,
the L1 dimension becomes 450 + 100 = 550 mm.

(4) Continuous installation

- Space required for collective installation and continuous installation:
When installing several units, leave the space between each unit considering passage for air and people.
- Open in the two directions.
- In case wall height (H) exceeds overall height of unit, add "h" dimension (h = wall height <H> – overall height of unit) to * marked dimension.

4. Lifting method and weight of product

[Fig. 4.0.1] (P.2)

⚠ Caution:

- **Be very careful to carry product.**
 - Do not have only one person to carry product if it is more than 20 kg.
 - PP bands are used to pack some products. Do not use them as a mean for transportation because they are dangerous.
 - Do not touch heat exchanger fins with your bare hands. Otherwise you may get a cut in your hands.
 - Tear plastic packaging bag and scrap it so that children cannot play with it. Otherwise plastic packaging bag may suffocate children to death.
 - When carrying in outdoor unit, be sure to support it at four points. Carrying in and lifting with 3-point support may make outdoor unit unstable, resulting in a fall of it.
- **Protect the corners on the unit that come in contact with the sling with padding.**

5. Installation of unit

5.1. Installation

[Fig. 5.1.1] (P.2)

Ⓐ M10 anchor bolt procured at the site. Ⓑ Corner is not seated.

- Fix unit tightly with bolts so that unit will not fall down due to earthquake or gust.
- Use concrete or angle for foundation of unit.
- Vibration may be transmitted to the installation section and noise and vibration may be generated from the floor and walls, depending on the installation conditions. Therefore, provide ample vibrationproofing (cushion pads, cushion frame, etc.).
- Be sure that the corners are firmly seated. If the corners are not firmly seated, the installation feet may be bent.

⚠ Warning:

- **Be sure to install unit in a place strong enough to withstand its weight. Any lack of strength may cause unit to fall down, resulting in a personal injury.**
- **Have installation work in order to protect against a strong wind and earthquake. Any installation deficiency may cause unit to fall down, resulting in a personal injury.**

When building the foundation, give full attention to the floor strength, drain water disposal <during operation, drain water flows out of the unit>, and wiring routes.

Down wiring precautions

When down wiring are performed, be sure that foundation and base work does not block the base through holes.

[Fig. 5.1.2] (P.2)

Ⓐ Bottom wiring through hole Ⓑ (bolt hole)

6. Drain piping work

[Fig. 6.0.1] (P.2)

Ⓐ Drain piping Ⓑ Socket R1
Ⓒ Drain trap
Ⓓ The drain pipe should extend below this level.
Ⓔ $\geq 2 \times$ External static pressure
Ⓕ $\geq 2 \times$ Ⓔ

1. The condensate drain socket (R1) is provided. The drain pipe is connected to the drain socket.
2. The drain pipe must be provided with a trap on the outside of the unit and also installed at an incline for proper drainage, as shown [Fig. 6.0.1] (P.2).
3. To prevent dew condensation and leakage, provide drain pipes with insulation.
4. Upon completion of the piping work, check that there is no leakage and that the water drains off properly.

7. Duct work

1. In case of side flow unit (factory setting) is equipped with horizontal supply and return air openings. Duct connection to the unit should be made with duct flanges and secured directly to the air openings with flexible duct connectors to avoid normal noise transmission.
2. For vertical air supply, a field supply plenum should be used. The figure below shows the recommended method for duct connection.
3. In case of top flow unit (modified when installed) is equipped with vertical supply and horizontal return air openings. Duct connection to the unit should be made with duct flanges and securely attached to the air openings with flexible duct connectors.
4. To prevent air leakage, all duct seams should be taped. Ducts run in air spaces that are not air-conditioned must be insulated and provided with a vapor barrier. Ducts exposed to the outside must be weather proofed. For quiet operation, we recommend that the insulation on the supply duct be placed inside, lining the duct.
5. Where ducts from the outside enter a building, the duct openings in the building should be sealed with weather stripping to prevent rain, duct, sand, etc. from entering the building.
6. Fans will not accept any external resistance to airflow and what provision is available if ductwork is to be fitted to the external fans.
7. Correctly sized filters must be fitted and there is no provision within the unit, however the filters (field supply) may be installed in the return air.
8. Duct earth wiring must be connected to the earth point of unit (⚡ mark point).

[Fig. 7.0.1] (P.3)

<A> Ex. Side flow

 Ex. Top flow

Ⓐ Duct Ⓑ Roof curb
Ⓒ Single duct divider Ⓓ Plenum divider
Ⓔ Insulator Ⓕ Keep duct-work length 850 mm or more
Ⓖ Rainproof the part where the duct flange is screwed on (Top flow only).

⚠ Caution:

- **Outlet duct is 850 mm or more necessary to construct.**
- **To connect the air conditioner main body and the duct for potential equalization.**

- Mount holes for outlet duct flange and inlet duct.

[Fig. 7.0.2] (P.3)

<A> In case of side flow

 In case of top flow

Ⓐ Inlet duct flange Ⓑ Outlet duct flange
Ⓒ Same as inlet and outlet duct flange Ⓓ 2×100 pitch = 200
Ⓔ 28- ϕ 3 holes (Inlet duct mount holes) Ⓕ 18- ϕ 3 holes (Outlet duct mount holes)

7.1. Fresh air inlet, duct installations, and operating restrictions

This unit has an fresh air inlet on each side of the unit. Use the one that suits a particular application.

[Fig. 7.1.1] (P.3)

- Ⓐ Fresh air inlet (on both sides)

⚠ Caution:

- ① Properly seal duct connections.
- ② Install a proper size filter at the opening of the inlet, and clean the filter on a regular basis.
- ③ Install a duct longer than 850 mm or block the opening of the inlet with a wire net to keep hands out of the inlet.

- ④ The opening of the connected duct must not be facing up as rain or snow will enter the duct.
- ⑤ Be sure that the temperature of the mixed air (return air and outside air) falls within the following ranges:
In the case of cooling operation: mixed air temperature 15 °CWB - 24 °CWB (30 - 80% RH)
In the case of heating operation: mixed air temperature 15 °CDB - 32 °CDB
- ⑥ Install a reverse air-flow prevention plate inside return and supply ducts to prevent the back flow of air during unit stoppage.

[Fig. 7.1.2] (P.3)

- Ⓐ Filter (Field supply)
- Ⓑ Fresh air inlet duct (Field supply)

8. Remote controller

8.1. Installing procedures

- (1) Select an installing position for the remote controller (switch box).
Be sure to observe the following precautions.

[Fig. 8.1.1.(1)] (P.4)

- Ⓐ Remote controller profile
- Ⓑ Required clearances surrounding the remote controller
- Ⓒ Temperature sensor
- Ⓓ Installation pitch

- ① The temperature sensors are located on both remote controller and unit. To use the temperature sensor on the remote controller, mainly use the remote controller for temperature setting or room temperature detection. Install the remote controller in such an area that can detect average room temperatures, free of direct sunlight, airflow from the air conditioner, and other such heating source.
- ② In either case when the remote controller is installed in the switch box or on the wall, provide the clearances indicated in the diagram.

Note:

Check that there is no electric wire left close to the remote controller sensor. If any electric wire is near the sensor, the remote controller may fail to detect a correct room temperature.

- ③ Procure the following parts locally:
Switch box for two pieces
Thin copper conduit tube
Lock nuts and bushings

- (2) Seal the service entrance for the remote controller cord with putty to prevent possible invasion of dew drops, water, cockroaches or worms.

<A> For installation in the switch box:

- When the remote controller is installed in the switch box, seal the junction between the switch box and the conduit tube with putty.

 For direct installation on the wall select one of the following:

B-1. To lead the remote controller cord from the back of the controller:

- Prepare a hole through the wall to pass the remote controller cord (in order to run the remote controller cord from the back), then seal the hole with putty.

B-2. To run the remote controller cord through the upper portion:

- Run the remote controller cord through the cut-out upper case, then seal the cut-out notch with putty similarly as above.

[Fig. 8.1.1.(2)] (P.4)

- Ⓒ Wall
- Ⓓ Conduit
- Ⓔ Lock nut
- Ⓕ Bushing
- Ⓖ Switch box
- Ⓗ Remote controller cord
- Ⓘ Seal with putty

- (3) Install the lower case in the switch box or on the wall.

[Fig. 8.1.1.(3)] (P.4)

<A> For installation in the switch box

- Ⓒ Switch box for two pieces
- Ⓓ Remote controller cord
- Ⓔ Cross-recessed, pan-head screw
- Ⓖ Seal the remote controller cord service entrance with putty

 For direct installation on the wall

- Ⓗ Wood screw

⚠ Caution:

Do not over-tighten the screws to possible deformed or broken lower case.

Note:

- Select a flat place for installation.
- Be sure to use two or more locations for securing of the remote controller in the switch box or on the wall.

8.2. Connecting procedures

- The remote controller cord can be extended up to a maximum of 200 m. Use electric wires or (two-core) cables of 0.3 mm² to 1.25 mm² for making connection of remote controller. Do not use multi-conductor cables to prevent possible malfunction of the unit.

- (1) Connect the remote controller cord to the terminal block at the lower case.

[Fig. 8.2.1] (P.4)

- Ⓐ To TB5 on the unit
- Ⓑ Terminal block TB6 in remote controller
No polarity

⚠ Caution:

- Do not use crimp-style terminals for connection to the remote controller terminal block to eliminate contact with the boards and resultant trouble.
- Prevent remote cord chips from getting into the remote controller. Electric shock or malfunction may result.

8.3. Fitting the upper case

[Fig. 8.3.1] (P.4)

- (1) To remove the upper case, put a slotted screwdriver tip in the latches as shown in the diagram then move the screwdriver in the direction of arrow.

- (2) To install the upper case, put the upper latches (at two locations) first, then fit the upper case into the lower case as illustrated.

[Fig. 8.3.2] (P.4)

Note:

Wiring hole for installing directly on the wall (or open wiring)

- Cut off the shaded area from the upper case using a knife, nippers, etc.
- Take out the remote control cord connected to the terminal block via this portion.

⚠ Caution:

- Do not move the screwdriver while inserting the tip far into the latches to prevent broken latches.
- Be sure to put the upper case securely in the latches by pressing it until a snap sounds. Loosely inserted, the upper case may fall down.

Note:

The operating section is covered with a protective sheet. Before using the unit, remember to remove the protective sheet.

8.4. Function selection

<Wired remote controller type>

(1) Function selection of remote controller

The setting of the following remote controller functions can be changed using the remote controller function selection mode. Change the setting when needed.

Item 1	Item 2	Item 3 (Setting content)
1. Change Language ("CHANGE LANGUAGE")	Language setting to display	• Display in multiple languages is possible.
2. Function limit ("FUNCTION SELECTION")	(1) Operation function limit setting (operation lock) ("LOCKING FUNCTION")	• Setting the range of operation limit (operation lock)
	(2) Use of automatic mode setting ("SELECT AUTO MODE")	• Setting the use or non-use of "automatic" operation mode
	(3) Temperature range limit setting ("LIMIT TEMP FUNCTION")	• Setting the temperature adjustable range (maximum, minimum)
3. Mode selection ("MODE SELECTION")	(1) Remote controller main/sub setting ("CONTROLLER MAIN/SUB")	• Selecting main or sub remote controller * When two remote controllers are connected to one group, one controller must be set to sub.
	(2) Use of clock setting ("CLOCK")	• Setting the use or non-use of clock function
	(3) Timer function setting ("WEEKLY TIMER")	• Setting the timer type
	(4) Contact number setting for error situation ("CALL")	• Contact number display in case of error • Setting the telephone number
4. Display change ("DISP MODE SETTING")	(1) Temperature display °C/°F setting ("TEMP MODE °C/°F")	• Setting the temperature unit (°C or °F) to display
	(2) Suction air temperature display setting ("ROOM TEMP DISP SELECT")	• Setting the use or non-use of the display of indoor (suction) air temperature
	(3) Automatic cooling/heating display setting ("AUTO MODE DISP C/H")	• Setting the use or non-use of the display of "Cooling" or "Heating" display during operation with automatic mode

[Function selection flowchart]

[1] Stop the air conditioner to start remote controller function selection mode. → [2] Select from item1. → [3] Select from item2. → [4] Make the setting. (Details are specified in item3) → [5] Setting completed. → [6] Change the display to the normal one. (End)

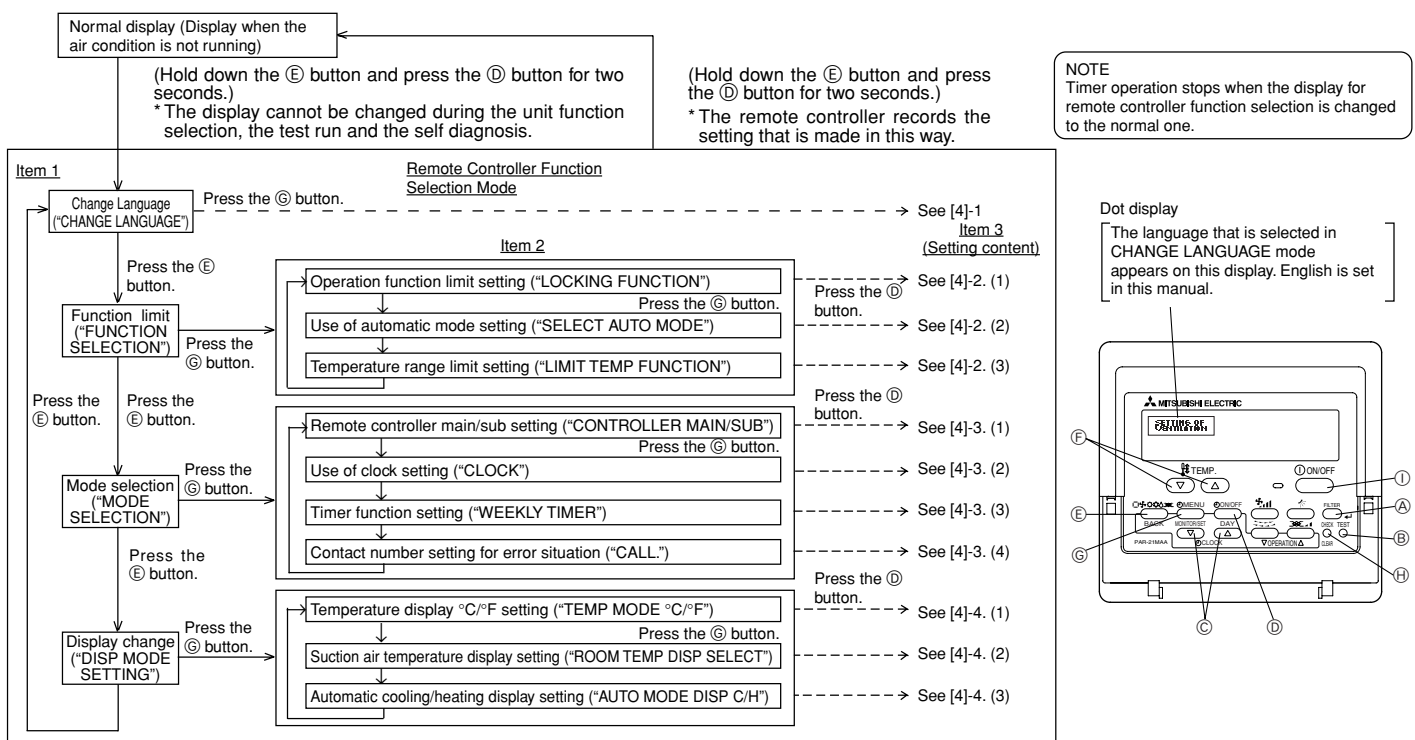

[Detailed setting]

[4]-1. CHANGE LANGUAGE setting

The language that appears on the dot display can be selected.

- Press the [**Ⓞ**MENU] button to change the language.
- ① Japanese (JP), ② English (GB), ③ German (D), ④ Spanish (E), ⑤ Russian (RU), ⑥ Italian (I), ⑦ Chinese (CH), ⑧ French (F)

[4]-2. Function limit

(1) Operation function limit setting (operation lock)

- To switch the setting, press the [**Ⓞ**ON/OFF] button.
- ① no1: Operation lock setting is made on all buttons other than the [**Ⓞ**ON/OFF] button.
- ② no2: Operation lock setting is made on all buttons.
- ③ OFF (Initial setting value):
Operation lock setting is not made.

* To make the operation lock setting valid on the normal screen, it is necessary to press buttons (Press and hold down the [FILTER] and [**Ⓞ**ON/OFF] buttons at the same time for two seconds.) on the normal screen after the above setting is made.

(2) Use of automatic mode setting

When the remote controller is connected to the unit that has automatic operation mode, the following settings can be made.

- To switch the setting, press the [**Ⓞ**ON/OFF] button.
- ① ON (Initial setting value):
The automatic mode is displayed when the operation mode is selected.
- ② OFF:
The automatic mode is not displayed when the operation mode is selected.

(3) Temperature range limit setting

After this setting is made, the temperature can be changed within the set range.

- To switch the setting, press the [**Ⓞ**ON/OFF] button.
- ① LIMIT TEMP COOL MODE:
The temperature range can be changed on cooling/dry mode.
- ② LIMIT TEMP HEAT MODE:
The temperature range can be changed on heating mode.
- ③ LIMIT TEMP AUTO MODE:
The temperature range can be changed on automatic mode.
- ④ OFF (initial setting): The temperature range limit is not active.
- * When the setting, other than OFF, is made, the temperature range limit setting on cooling, heating and automatic mode is made at the same time. However, the range cannot be limited when the set temperature range has not changed.
- To increase or decrease the temperature, press the [**Ⓞ**TEMP (▽) or (△)] button.
- To switch the upper limit setting and the lower limit setting, press the [**Ⓞ**TEMP] button. The selected setting will flash and the temperature can be set.
- Settable range
Cooling/Dry mode: Lower limit: 19°C ~ 30°C Upper limit: 30°C ~ 19°C
Heating mode: Lower limit: 17°C ~ 28°C Upper limit: 28°C ~ 17°C
Automatic mode: Lower limit: 19°C ~ 28°C Upper limit: 28°C ~ 19°C
- * The settable range varies depending on the unit to connect (Mr. Slim units, Free-plan units, and intermediate temperature units)

[4] -3. Mode selection setting

(1) Remote controller main/sub setting

- To switch the setting, press the [⊖ ON/OFF] button.
- ① Main: The controller will be the main controller.
- ② Sub: The controller will be the sub controller.

(2) Use of clock setting

- To switch the setting, press the [⊖ ON/OFF] button.
- ① ON: The clock function can be used.
- ② OFF: The clock function cannot be used.

(3) Timer function setting

- To switch the setting, press the [⊖ ON/OFF] button (Choose one of the followings.).

- ① WEEKLY TIMER (Initial setting value):
The weekly timer can be used.
 - ② AUTO OFF TIMER: The auto off timer can be used.
 - ③ SIMPLE TIMER: The simple timer can be used.
 - ④ TIMER MODE OFF: The timer mode cannot be used.
- * When the use of clock setting is OFF, the "WEEKLY TIMER" cannot be used.

(4) Contact number setting for error situation

- To switch the setting, press the [⊖ ON/OFF] button.
- ① CALL OFF: The set contact numbers are not displayed in case of error.
- ② CALL **** * : The set contact numbers are displayed in case of error.
CALL_: The contact number can be set when the display is as shown on the left.

- Setting the contact numbers

To set the contact numbers, follow the following procedures. Move the flashing cursor to set numbers. Press the [TEMP. (▽) and (△)] button to move the cursor to the right (left). Press the [CLOCK (▽) and (△)] button to set the numbers.

[4] -4. Display change setting

(1) Temperature display °C/°F setting

- To switch the setting, press the [⊖ ON/OFF] button.
- ① °C: The temperature unit °C is used.
- ② °F: The temperature unit °F is used.

(2) Suction air temperature display setting

- To switch the setting, press the [⊖ ON/OFF] button.
- ① ON: The suction air temperature is displayed.
- ② OFF: The suction air temperature is not displayed.

(3) Automatic cooling/heating display setting

- To switch the setting, press the [⊖ ON/OFF] button.
- ① ON: One of "Automatic cooling" and "Automatic heating" is displayed under the automatic mode is running.
- ② OFF: Only "Automatic" is displayed under the automatic mode.

(2) Unit Function Selection

Set the functions of each unit from the remote controller, as required. The functions of each unit can be selected only from the remote controller. Set the functions by selecting the necessary items from Table 1 and Table 2. (Default settings are also shown below)

Table 1. Itemized functions of the entire refrigerant system (select unit number 00 to 15)

Function	Settings	Mode no.	Setting no.	Check	Default settings	Remarks
Power failure automatic recovery	Not available	01	1		○	Approx. 4-minute wait-period after power is restored.
	Available		2			
Indoor temperature detection	Unit operating average	02	1		○	
	Set by unit's remote controller		2			
	Remote controller's internal sensor		3			
LOSSNAY connectivity	Not Supported	03	1		○	
	Supported (unit is not equipped with outdoor-air intake)		2			
	Supported (unit is equipped with outdoor-air intake)		3			
Power voltage	240 V	04	1		○	
	220 V, 230 V		2			

Table 2. Itemized functions of the unit (select unit numbers 01 to 04 or AL)

Function	Settings	Mode no.	Setting no.	Check	Default settings	Remarks
Filter sign	100 Hr	07	1			
	2500 Hr		2			
	No filter sign indicator		3		○	
Fan operation during thermo off in heating operation	Operation	25	3		○	When selecting fan operation "Stop", set setting no. of Mode no. "02" in Table 1 to "3". Be sure to place the remote controller inside the room to be air-conditioned so that it can monitor the room temperature.
	Stop		2			
Fan operation during thermo off in cooling operation	Operation	27	1		○	When selecting fan operation "Stop", set setting no. of Mode no. "02" in Table 1 to "3". Be sure to place the remote controller inside the room to be air-conditioned so that it can monitor the room temperature.
	Stop		2			

Note:
When the indoor unit functions were changed using the function selection after installation is complete, always indicate the set contents by entering ○ or other mark in the appropriate check field of Table 1 and Table 2.

[Function selection flow]

First grasp the function selection flow. The following describes setting of "Power voltage" of Table 1 as an example.
 (For the actual setting procedure, see [Setting procedure] ① to ⑩.)

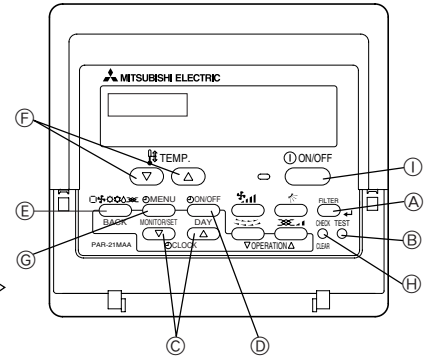
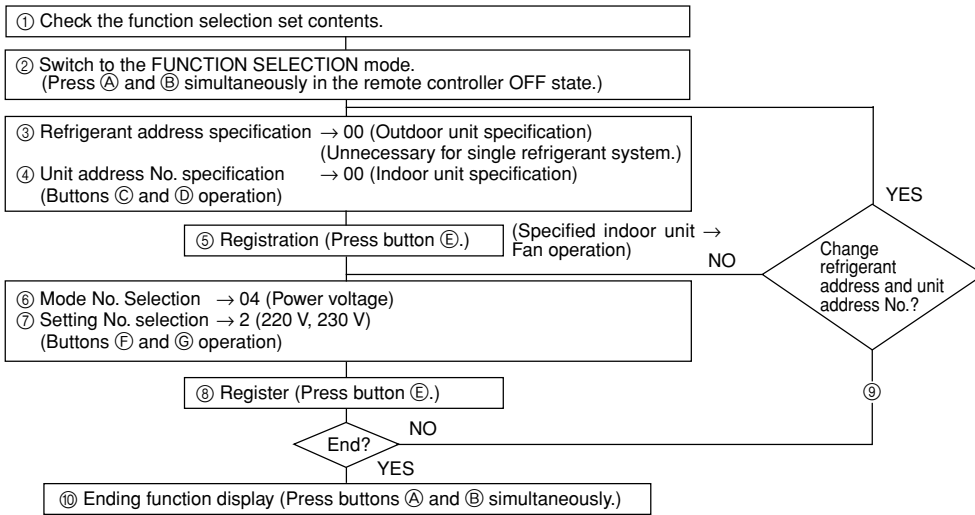

[Procedure] (Set only when change is necessary.)

① Check the set contents of each mode. When the set contents of a mode were changed by function selection, the functions of that mode also change. Check the set contents as described in steps ② to ⑦ and change the setting based on the entries in the Table 1 and Table 2. (Refer default settings, when change the setting)

- ② Set the remote controller to Off. Press and hold down the A [FILTER] and B [TEST] buttons at the same time for two seconds or longer. "FUNCTION SELECTION" blinks for a while, then the remote controller display changes to the display shown below.
- ③ Set the outdoor unit refrigerant address No. When the C [CLOCK (▽)] and D [CLOCK (△)] buttons are pressed, the refrigerant address No. decreases and increases between 00 and 15. Set it to the refrigerant address No. whose function you want to select. (This step is unnecessary for single refrigerant system.)

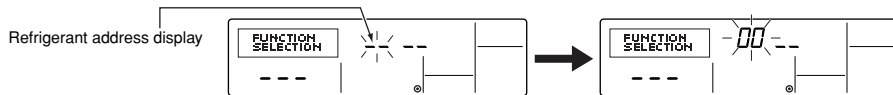

* If the remote controller enters the OFF state after the "FUNCTION SELECTION" and room temperature displays "BB" have flashes for two seconds, communication is probably abnormal. Make sure there are no noise sources near the transmission line.

Note:
 If you make a mistake during operation, end function selection by step ⑩ and repeat selection from step ②.

- ④ Set the indoor unit address No. Press the E [ON/OFF] button. The unit address No. display "--" flashes. When the C [CLOCK (▽)] and D [CLOCK (△)] buttons are pressed, the unit address No. changes in 00 → 01 → 02 → 03 → 04 → AL order. Set it to the unit address No. of the indoor unit whose functions you want to set.

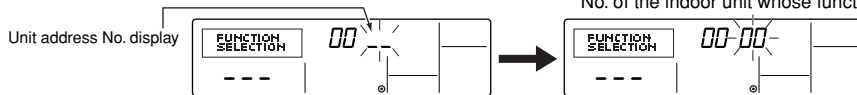

- * When setting mode 01 to 04, set the unit address No. to "00".
- * When setting modes 07, 25, 27:
 - When setting functions for a unit in an independent system, set the unit number to 01.

- ⑤ Refrigerant address and unit address No. registration Press the F [REGISTRATION] button. The refrigerant address and unit address No. are registered. After a while, the mode No. display "--" flashes.

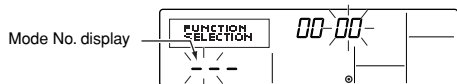

- * When "BB" flashes at the room temperature display, the selected refrigerant address is not in the system. When "F" is displayed at the unit address No. display, and when it flashes together with the refrigerant address display, the selected unit address No. does not exist. Correctly set the refrigerant address and unit address No. by repeating steps ② and ③.

- ⑥ When registered using the F [REGISTRATION] button, the registered indoor unit begins fan operation. When you want to know the location of the indoor units of the unit address No. whose functions were selected, check here. When the unit address No. is 00 or AL, all the indoor units of the selected refrigerant address perform the fan operation.

Ex) When refrigerant address 00, unit address No. = 01 registered

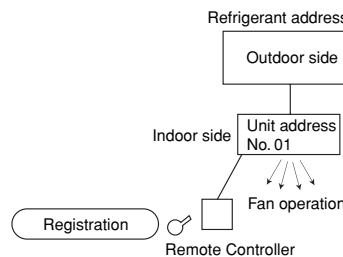

- * When grouping by different refrigerant systems and an indoor unit other than the specified refrigerant address performs the fan operation, the refrigerant address set here is probably duplicated. Recheck the refrigerant address at the outdoor unit DIP switches.

⑥ Mode No. selection

Select the mode No. you want to set with the \ominus [TEMP. (∇) and (Δ)] buttons. (Only the settable mode numbers can be selected.)

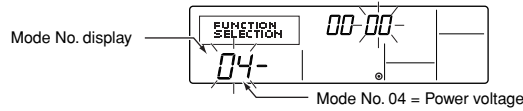

⑦ Select the setting contents of the selected mode.

When the \ominus [MENU] button is pressed, the current setting No. flashes. Use this to check the currently set contents.

Select the setting No. using the \ominus [TEMP. (∇) and (Δ)] buttons.

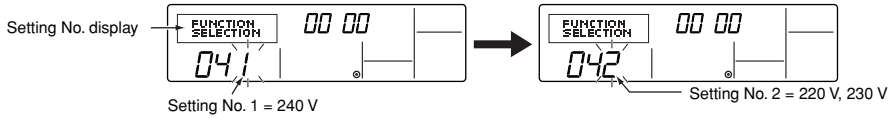

⑧ The contents set at steps ③ to ⑦ are registered.

When the \ominus [ON/OFF] button is pressed, the mode No. and setting No. flash and registration begins. The flashing mode No. and setting No. change to a steady light and setting ends.

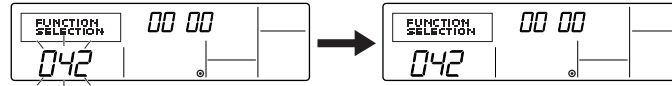

* When "--" appears at the mode No. and setting No. displays and "88" flashes at the room temperature display, communication is probably abnormal. Make sure there are no noise sources near the transmission line.

⑨ To select more functions, repeat steps ③ to ⑧.

⑩ End function selection.

Press and hold down the Δ [FILTER] and \ominus [TEST] buttons at the same time for two seconds or longer.

After a while, the function selection display disappears and the remote controller returns to the air conditioner off display.

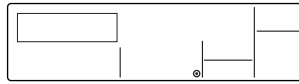

* Do not operate the air conditioner from the remote controller for 30 seconds after the end of function selection.

Note:

When the functions of an indoor unit were changed by function selection after the end of installation, always indicate the set contents by entering a \circ or other mark in the appropriate check field of Table 1 and Table 2.

9. Electrical wiring

Precautions on electrical wiring

Warning:

- Electrical work should be done by qualified electrical engineers in accordance with "Engineering Standards For Electrical Installation" and supplied installation manuals. Special circuits should also be used. If the power circuit lacks capacity or has an installation failure, it may cause a risk of electric shock or fire.
- Always use the designated cable for wiring, and connect it correctly. Secure it so that the cable applies no external pressure to the terminal connection. If the connection is faulty or the cable is not fully secured, overheating or fire could result.
- Be sure to use specified cables and connect them firmly so that no external wiring force is exerted on terminal connections. Loose connections may cause heat or fire.

1. Be sure to take power from the special branch circuit.
2. Be sure to install an earth leakage breaker to the power.
3. Install the unit to prevent that any of the control circuit cables (remote controller) is brought in direct contact with the power cable outside the unit.
4. Ensure that there is no slack on all wire connections.
5. Remote controller cable above the ceiling may be bitten by mice. Use as many metal pipes as possible to insert the cable into them for protection. Where the remote controller cable is exposed, protect the cable by running it through a metal pipe.
6. Never connect the power cable to leads for the remote controller cables. Otherwise the cables would be broken.
7. Fix power source wiring to control box by using buffer bushing for tensile force (PG connection or the like).
8. Set up the unit so that the wiring for the remote controller and the M-NET (MELANS) wiring do not produce electrical interference with the power supply cable. (Do not route them together in the same conduit.)
9. Be sure to provide designated grounding work to the unit.
10. Give some allowance to wiring for electrical part box of the unit, because the box is sometimes removed at the time of service work.

Caution:

- Be sure to put the unit to the ground on the outdoor unit side. Do not connect the earth cable to any gas pipe, water pipe, lightning rod, or telephone earth cable. Incomplete grounding may cause a risk of electric shock.
- Some installation sites may require installation of an earth leakage breaker. Failure to install it may result in an electric shock.
- Always use an earth leakage breaker and fuse with the specified capacity. Use of a fuse with a capacity larger than that specified, or use of a piece of wire or copper wire may cause breakdown or fire.
- Depending on the location of the unit, a current leakage breaker may be required. If a current leakage breaker is not installed, electric shock could result.
- Do not use breakers or fuses with a capacity different from the correct one. If large-capacity fuses, wire, or copper wiring are used, accident or fire may result.

The following table is an example. The selection of other capacities should be determined in accordance with the relevant standards.

[Wiring example] (For metal pipe)

	Power Cable	Breaker Capacity	Fuse	Remote controller cable	Grounding wire	Max. Permissible system impedance *1
PRH-P200MYA	10 mm ² or thicker	63 A	63 A	Cable or wire of 0.3 ~ 1.25 mm ² (Max.DC 12 V)	10 mm ² or thicker	0.07 Ω
PRH-P250MYA	10 mm ² or thicker	63 A	63 A		10 mm ² or thicker	0.05 Ω

Note:

*1: This device is intended for the connection to a power supply system with a maximum permissible system impedance Z_{MAX} of 0.07 Ω PRH-P200, 0.05 Ω PRH-P250 at the interface point (power service box) of the user's supply.

The user has to ensure that this device is connected only to a power supply system which fulfills the requirement above.

If necessary, the user can ask the public power supply company for the system impedance at the interface point.

[Selecting earth leakage breaker (NV)]

To select NF or NV instead of a combination of Class B fuse with switch, use the following:

Fuse (class B)	63 A
Earth leakage breaker ELB (with over-load protection)	NV100-SW 60 A 100 mA 0.1s or less

NV is a product name of MITSUBISHI.

- Power supply cords of appliances shall not be lighter than design 245 IEC57.
- A switch with at least 3 mm contact separation in each pole shall be provided by the Air conditioner installation.

Example

[Fig. 9.0.1] (P.4)

- (1) Normal Connecting
 - (2) Grouping (16 units)
- Ⓐ Power supply Ⓑ Earth leakage breaker
Ⓒ Wiring circuit breaker or isolating switch
Ⓓ Remote controller Ⓔ Address

[Unit-MA remote controller cable/cord] (For metal pipe)

MA remote controller	
Types of cable/cord	When extending the remote controller cable, remote controller cables shall not be lighter than design 245 IEC53.
Number of cable/cord	2 core cable
Diameter of cable/cord	0.3 ~ 1.25 mm ²
Total extension	Max. 200 m

9.1. Address settings

Unit address settings

- During address setting, set all the dip switches SW1 (3 - 6) on the outdoor-side controller board to <when shipped from factory: all OFF>. (Address setting is not necessary for 1:1 or Free multi-component systems.)
- Functions of SW1 according to switch setting are shown below.
- To control a group of units, address must be assigned to each unit.

(SW1 of outdoor-side controller)

		Model	Functions according to switch setting	
			ON	OFF
	1	-	-	-
	2	Error history clear	Clear	Ordinary
	3	Refrigerant system address setting	Unit address Settings 0 - 15	
	4	↑		
5	↑			
6	↑			

[Fig. 9.1.1] (P.5)

9.2. Wiring connection

- Using the conduit mounting plates
Conduit mounting plates are supplied in three sizes (ø27, ø34, ø40). Use the mounting plate that fits the outer diameter of the wire to be used.

[Fig. 9.2.1] (P.5)

- Ⓐ When installing conduct from bottom panel
- Ⓑ When installing conduct from front panel
- Ⓒ Mounting plate (attached)
- Ⓓ Knock-out hole

10. Specifications for installing the belt

1. Set the parallel angle of the fan and the motor pulley as shown in the [Fig. 10.0.1] and table 1.
2. Set the tension of the per one belt when the flexion load is within the range as shown in the [Fig. 10.0.2] and table 2 below at the proper flexion.
3. Adjust the suitable tension after the belt sit properly across the pulley (after more 24 - 28 hours working).
When the new belt is used, adjust the suitable tension about the 1.3 times of the maximum value of the flexion load.
4. Readjust the belt every 2,000 hours after the first adjustment.
Exchange the belt when the belt's surroundings length has expanded by 2 % including the first expansion of the belt. (about 1 %)
(about 8,000 hours converted working time)
When selecting fan operation "Stop" (Mode no. 25 "2" in table 2 of page 11), readjust the belt every 1,000 hours after the first adjustment.

[Fig. 10.0.1] / [Fig. 10.0.2] (P.5)

- <A> Parallel degree of pulley
 Belt tension
Ⓐ Flexion load (W)

table 1

pulley	parallel angle	K (°)	note
		10 or less	gap of 3 mm every 1 m

table 2

type	pulley		Flexion load W (N)
	smaller out diameter (mm)		
B	~ 135		22 ~ 29
	136 ~ 160		27 ~ 34
	161 ~		29 ~ 37

11. Modification method of fan direction (From side flow to top flow)

This product can be changed from side flow to top flow in the field.
Modify if necessary as follows.

[Fig. 11.0.1] (P.5)

- Ⓐ Top panel Ⓑ Cover (outer side) Ⓒ Flange
Ⓓ Panel Ⓔ Fan Ⓕ Cover (inner side)...2pcs

- ① Remove the top panel Ⓐ, cover (outer side) Ⓑ, flange Ⓒ, panel Ⓓ and cover (inner side) Ⓕ. (STEP 1)
- ② Modify the fan Ⓔ direction. (STEP 2)
- ③ Re-install the top panel Ⓐ, cover Ⓑ, flange Ⓒ and panel Ⓓ. (STEP 3)

Note:

In the case of top flow, the inner cover Ⓕ is not necessary.

12. Test run

12.1. Before test run

The test run can be carried out either from the unit or remote controller.

1. Checklist

- After wiring of units are complete, check that refrigerant is not leaking, the power and control wires are not loose, and the poles are not reversed.
- Use a 500 V insulation resistance tester to make sure that the resistance between the power terminal and the ground is 1.0 MΩ or more. If it is less than 1.0 MΩ, do not operate the unit.
- Make sure there is no malfunction in the unit. (If there is a malfunction, you can diagnose it using LED1 on the outdoor-side controller board.)
- Check the electrical power phase. If the phase is reversed, the fan may rotate in the wrong direction or stop, or unusual sounds may be produced.
- Starting at least 12 hours before the test run, send current through the crank-case heater. (If the current is running for a shorter period of time, damage to the compressor could result.)
- For specific models requiring changing of settings for selection of power supply ON/OFF capability, make proper changes referring to the description for Selection of Functions through Remote Controller.

After the above checks are complete, carry out the test run as indicated in the following outline.

12.2. Test run procedures

1) Remote controller

Operating procedures

① Turn on the main power supply

While the display on the remote controller indicates “CENTRALLY CONTROLLED”, the remote controller is disabled. Turn off the “CENTRALLY CONTROLLED” indicator before using the remote controller.

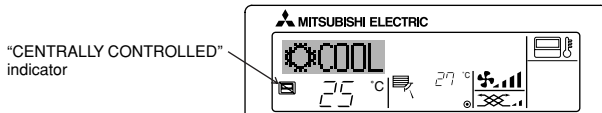

② Press the [TEST] button twice successively within three seconds. Test run starts.

“TEST RUN” and “OPERATION MODE” are displayed alternately.

③ Press [ON/OFF] button

Cooling mode: Cool air should start to blow.

Heating mode: Warm air should start to blow (after a while).

④ Check the outdoor-side fan for correct running

The unit features automatic capacity control to provide optimum outdoor-side fan speeds. The fan keeps running at a low speed to meet the current outside air condition unless it exceeds its available maximum power. Then, in actuality, the fan may stop or run in the reverse direction depending on the outside air, which does not mean malfunction.

⑤ Press the [ON/OFF] button to reset the test run in progress

- The test run will be automatically shut down after two hours in response to the AUTO STOP setting of two hours on the timer.
- During the test run, the room temperature display shows the unit indoor-side liquid piping temperatures.
- In the case of the test run, the OFF timer will activate, and the test run will automatically stop after two hours.
- The room temperature display section shows the control temperature for the units during the test run.
- Check that the units are running properly operation. Malfunctions may not be displayed even if the wiring is incorrect.

⑥ Register a telephone number.

The telephone number of the repair shop, sales office, etc., to contact if an error occurs can be registered in the remote controller. The telephone number will be displayed when an error occurs. For registration procedures, refer to 8.4 Function selection of remote controller.

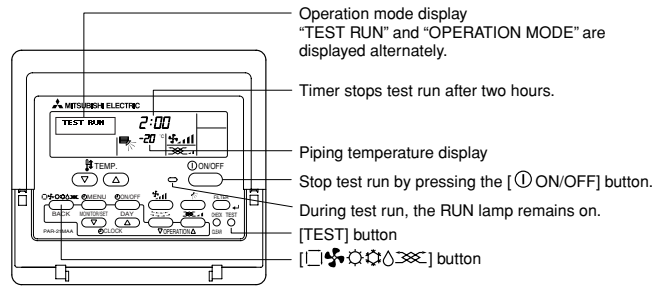

(*1)

After turning ON the power, the system will go into startup mode, and the remote controller operation lamp (green) and the display section's "PLEASE WAIT" will flash. Also, in the case of the indoor-side controller board substrate LEDs, LED 1 and LED 2 light up (when address is 0) or become dim (when address is not 0), and LED 3 flashes. In the case of the outdoor-side controller board substrate LED 1 display, [] and [] are displayed alternately at 1-second intervals.

- If one of the above operations does not function correctly, the following causes should be considered, and if applicable, dealt with. (The following symptoms have been determined under test run mode. Note that "startup" in the chart means the *1 display above.)

Symptoms		Cause
Remote Controller Display	Outdoor Substrate LED Display	
Remote controller is displaying "PLEASE WAIT", and operation is not possible.	After "startup" display, "00" is displayed (correct operation).	• After power is turned ON, system startup lasts for about 2 mins., and "PLEASE WAIT" is displayed (correct operation).
After power is turned ON, "PLEASE WAIT" is displayed for 3 mins., then error code is displayed.	After "startup" display, error code is displayed.	• Outdoor-side unit's safeguard installation connector is open.
	After "startup" display, "F1" (negative phase) is displayed.	• Negative phase and open phase of outdoor unit's power terminal board (Single phase: L, N, ⊕ / triple phase: L1, L2, L3, N, ⊕)
Power is turned ON, and "EE" or "EF" are displayed after "PLEASE WAIT" is displayed.	After "startup" display, "00" or "EE" is displayed ("EE" is displayed when a test run is made).	• Incorrect connection of outdoor terminal board (Single phase: L, N, ⊕ / triple phase: L1, L2, L3, N, ⊕ grounding and S1, S2, S3)
	After "startup" display, "EA" (error for number of units) or "Eb" (unit number error) is displayed.	• Unit construction differ
Display messages do not appear even when remote controller operation switch is turned ON (operation lamp does not light up).	After "startup" display, "00" is displayed (correct operation).	• Wiring for the unit is not connected correctly. (Polarity is wrong for S1, S2, S3)
	After "startup" display, "00" is displayed (correct operation).	• Remote controller transmission wire short
	After "startup" display, "00" is displayed (correct operation).	• There is no unit for address 0 (address is something other than 0).
Operation display appears but soon disappears even when remote controller operations are executed.	After "startup" display, "00" is displayed (correct operation).	• Remote controller transmission wire burnout
	After "startup" display, "00" is displayed (correct operation).	• After cancellation of function selection, operation is not possible for about 30 secs. (correct operation).

* Press the remote controller's "CHECK" button twice consecutively to be able to run a self-check. See the chart below for content of error code displays.

LCD	Nonconformity Content	LCD	Nonconformity Content	LCD	Nonconformity Content
P1	Suction sensor error	P8	Pipe temperature error	E6 - EF	Signal error between indoor-side controller board and outdoor-side controller board
P2	Piping (liquid pipe) sensor error	P9	Piping (2-phase pipe) sensor error	- - - -	No error history
P4	Drain sensor error	U0 - UP	Unit nonconformity	FFFF	No relevant unit
P5	Drain overflow safeguard operation	F1 - FA	Unit nonconformity		
P6	Freezing/overheating safeguard operation	E0 - E5	Signal error between remote controller and unit		

See the chart below for details of the LED displays (LED 1, 2, 3) on the indoor-side controller board.

LED 1 (microcomputer power supply)	Displays the ON/OFF of power for control. Check that this is lit during normal use.
LED 2 (remote controller feed)	Displays the ON/OFF of feed to wired remote controller. Is only lit for the unit of outdoor-side controller board with address "00".
LED 3 (indoor and outdoor signals)	Displays signal between indoor-side and outdoor-side controller boards. Check that this is flashing during normal use.

2) Unit

1) Check Items

- After installation of the unit, and electric wiring work, check that the unit is free from leaks of refrigerant, loosened connections, and incorrect polarity.
- Check that there is no negative phase and open phase. (The F1 message for negative phase and the F2 message for open phase will flash at LED 1 on the outdoor-side controller board. If this happens, rewire correctly.)
- Measure the impedance between power terminals (Single phase: L, N, ⊕ / triple phase: L1, L2, L3, N, ⊕) and the ground with a 500 V Megger and check that it is 1.0 MΩ or more. Do not operate the equipment if measurement is less than 1.0 MΩ.
- When there is no error at the unit.
(If there is an error at the unit, it can be evaluated at LED 1 [digital display] of the outdoor-side controller board.)
- The stop valves are open both the liquid and gas sides.
After checking the above, execute the test run in accordance with the following.

2) Test run start and finish

- Operation from the indoor-side controller board
Execute the test run using the installation manual for the indoor-side controller board.

- Operation from the outdoor-side controller board
Execute settings for test run start, finish and operation mode (cooling, heating) using the DIP switch SW 4 on the outdoor-side controller board.

[Fig. 12.2.1] (P.5)

- Ⓐ Stop
- Ⓑ Cooling
- Ⓒ Operation
- Ⓓ Heating

① Set the operation mode (cooling, heating) using SW 4-2

② Turn ON SW 4-1, The operation mode for SW 4-2 will be adhered to, and the test run will commence

③ Turn OFF SW 4-1 to finish the test run

- There may be a faint knocking noise emitted from the proximity of the fan during the test run. This is torque fluctuation occurring due to control of fan revolutions. There is no problem with the product.

Note:

The SW 4-2 operation mode cannot be changed during the test run. (To change test run mode, stop the equipment with SW 4-1, change the operation mode, then restart test run with SW 4-1.)

- If the 2-hour timer is set, the test run will stop automatically after 2 hours.
- During the test run, the room temperature display shows the unit indoor-side liquid piping temperatures.

12.3. Self-check

Retrieve the error history of each unit using the remote controller.

① Switch to the self check mode.

When the [CHECK] button is pressed twice successively within three seconds, the display shown below appears.

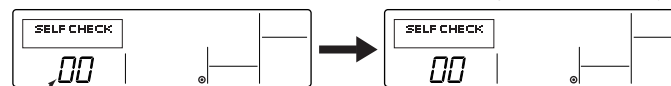

Self check address or self check refrigerant address

② Set the address or refrigerant address No. you want to self check.

When the [TEMP.] (▽) and [TEMP.] (△) buttons are pressed, the address decreases and increases between 01 and 50 or 00 and 15. Set it to the address No. or refrigerant address No. you want to self check.

Approximately three seconds after the change operation, the self check refrigerant address changes from flashing to a steady light and self check begins.

③ Self check result display <Error history> (For the contents of the error code, refer to 13. Troubleshooting, error code list.)

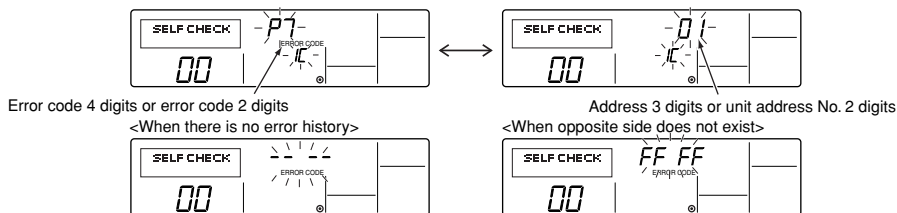

Error code 4 digits or error code 2 digits
<When there is no error history>

Address 3 digits or unit address No. 2 digits
<When opposite side does not exist>

④ Error history reset

The error history is displayed in ③ Self check results display.

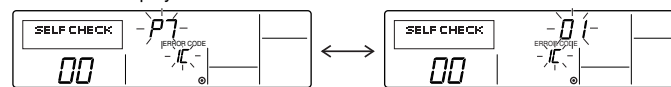

When the [MENU] button is pressed twice successively within three seconds, the self check address or refrigerant address flashes.

When the error history was reset, the display shown below appears. When error history reset failed, the error contents are displayed again.

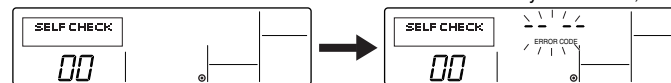

⑤ Self check reset

There are the following two ways of resetting self check.

Press the [CHECK] button twice successively within three seconds → Resets self check and returns to the state before self check.

Press the [ON/OFF] button → Self check resets and indoor units stop.

(When operation is prohibited, this operation is ineffective.)

12.4. Remote controller check

If operation cannot be carried out from the remote controller, use this function to diagnose the remote controller.

① First check the power mark.

When normal voltage (DC12V) is not applied to the remote controller, the power mark goes off.
When the power mark is off, check the remote controller wiring and the indoor unit.

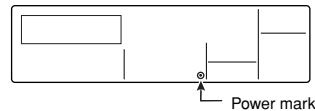

② Switch to the remote controller check mode.

When the **[CHECK]** button is held down for five seconds or longer, the display shown below appears.



When the **[FILTER]** button is pressed, remote controller check begins.



③ Remote controller check result

When remote controller is normal

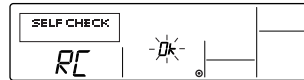

Since there is no problem at the remote controller, check for other causes.

When the problem is other than the checked remote controller

(Error code 2) "E3" "6833" "6832" flash → Cannot send

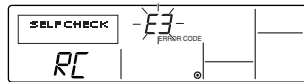

There is noise on the transmission line, or the indoor unit or another remote controller is faulty. Check the transmission line and the other remote controllers.

When remote controller is faulty

(Error display 1) "NG" flashes → Remote controller send/receive circuit abnormal

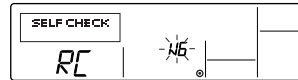

Remote controller switching is necessary.

(Error display 3) "ERC" and data error count are displayed → Data error generation

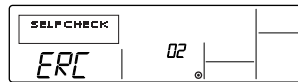

"Data error count" is the difference between the number of bits of remote controller send data and the number of bits actually sent to the transmission line. In this case, the send data was disturbed by the noise, etc. Check the transmission line.

When data error count is 02

Remote controller send data
Send data on transmission line

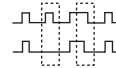

④ Remote controller check reset

When the **[CHECK]** button is held down for five seconds or longer, remote controller check resets and the "PLEASE WAIT" and RUN lamp flash. Approximately 30 seconds later, the remote controller returns to the state before remote controller check.

13. Troubleshooting



13.1. How to handle problems with the test run

Error code list: details

Remote controller display	MELANS display	Error details	Problem location
E0	6831,6834	Remote controller communication – reception error	Remote Controller
E1, E2	6201,6202	Remote controller board error	Remote Controller
E3	6832,6833	Remote controller communication – transmission error	Remote Controller
E4	6831,6834	Remote controller communication – reception error	Indoor-side controller board
E5	6832,6833	Remote controller communication – transmission error	Indoor-side controller board
E6	6740,6843	Communication between indoor-side and outdoor-side controller boards – reception error	Indoor-side controller board
E7	6841,6842	Communication between indoor-side and outdoor-side controller boards – transmission error	Indoor-side controller board
E8	6840,6843	Communication between indoor-side and outdoor-side controller boards – reception error	Outdoor-side controller board
E9	6841,6842	Communication between indoor-side and outdoor-side controller boards – transmission error	Outdoor-side controller board
EA	6844	Connection wiring error (interference, loose)	Outdoor-side controller board
EB	6845	Connection wiring error (interference, loose)	Outdoor-side controller board
EC	6846	Excessive time in use	Outdoor-side controller board
ED	0403	Serial communication error	Outdoor-side controller board
EE	0403	Serial communication error	M-NET board
F1	4103	Reverse phase, out of phase verification	Outdoor-side controller board
F8	4115	Faulty input circuit	Outdoor-side controller board
A0	6600	Duplicated M-NET address setting	M-NET board
A2	6602	M-NET error in PH/W transmission	M-NET board
A3	6603	M-NET bus busy	M-NET board
A6	6606	M-NET communication error with P transmission	M-NET board
A7	6607	M-NET error – no ACK	M-NET board
A8	6608	M-NET error – no response	M-NET board
EF	undefined	Undefined error code	–
U2	1102	Discharge temperature error	Outdoor-side controller board
U2	1108	CN23 Short-circuit Connector Unplugged	Outdoor-side controller board
U3	5104	Open/short in discharge temp thermistor	Outdoor-side controller board
U4	5105	Open/short in liquid temp or condenser/evaporator temp thermistor	Outdoor-side controller board
U6	4101	Compressor overcurrent interruption (51C operation)	Outdoor-side controller board

Remote controller display	MELANS display	Error details	Problem location
UE	1302	High pressure error (63H1 operation)	Outdoor-side controller board
UL	1300	Low pressure error (63L operation)	Outdoor-side controller board
F8	4115	Power synchronous idle circuit error	Outdoor-side controller board
P1	5101	Inlet sensor error	Indoor-side controller board
P2	5102	Piping (liquid pipe) sensor error	Indoor-side controller board
P4	2503	Drain sensor error	Indoor-side controller board
P5	2502	Drain overflow protector operation	Indoor-side controller board
P5	2500	Water leak error	Indoor-side controller board
P6	1503	Freeze prevention operation	Indoor-side controller board
P6	1504	Surge prevention operation	Indoor-side controller board
P8	1110	Piping temperature error	Indoor-side controller board
P9	5103	Piping (2-phase pipe) sensor error	Indoor-side controller board

- Depending on the position of the SW2 switch on the outdoor unit board, the segments light up to indicate the running condition of the unit and the particulars of the check code.

SW2 setting 123456	Item	Display contents																														
000000	Operation mode/relay output	tens place O: stop C: cooling H: heating d: defrosting units place 1: SV1 2: 21S4 4: 52C	Relay output = SV1 + 21S4 + 52C Ex. During cooling mode, when 52C and SV1 are ON: C5 When an error occurs, the error code and error signal (*1) are displayed in alternation.																													
011110	Outdoor unit control condition	Control mode display system																														
010110	Indoor-side control condition (IC1)	 	<table border="1"> <thead> <tr> <th rowspan="2">Display</th> <th colspan="2">Control mode</th> </tr> <tr> <th>Indoor-side</th> <th>Outdoor-side</th> </tr> </thead> <tbody> <tr> <td>0</td> <td>Ordinary</td> <td>←</td> </tr> <tr> <td>1</td> <td>Hot adjustment</td> <td>←</td> </tr> <tr> <td>2</td> <td>Defrosting</td> <td>←</td> </tr> <tr> <td>3</td> <td>—</td> <td>←</td> </tr> <tr> <td>4</td> <td>Heater ON</td> <td>←</td> </tr> <tr> <td>5</td> <td>Freeze prevention</td> <td>←</td> </tr> <tr> <td>6</td> <td>Surge prevention</td> <td>←</td> </tr> <tr> <td>7</td> <td>Compressor OFF</td> <td>←</td> </tr> </tbody> </table>	Display	Control mode		Indoor-side	Outdoor-side	0	Ordinary	←	1	Hot adjustment	←	2	Defrosting	←	3	—	←	4	Heater ON	←	5	Freeze prevention	←	6	Surge prevention	←	7	Compressor OFF	←
Display	Control mode																															
	Indoor-side	Outdoor-side																														
0	Ordinary	←																														
1	Hot adjustment	←																														
2	Defrosting	←																														
3	—	←																														
4	Heater ON	←																														
5	Freeze prevention	←																														
6	Surge prevention	←																														
7	Compressor OFF	←																														
011100	Error code history 1	The error code (ex. U8, UA) and error indicator (*1) are displayed in alternation.																														
111100	Error code history 2																															

*1 Display system for error indicator

The indicator corresponds to the following numbers

0 Outdoor unit

1 Indoor unit

13.2. The following occurrences are not problems or errors

Problem	Remote controller display	Cause
The fan setting changes during heating.	Ordinary display	During thermostat OFF mode, light air or low air operation will take place. During thermostat ON mode, light air or low air will switch automatically to set notch on the basis of time or piping temperature.
The fan stops during heating.	Defrosting display	During defrosting, the fan will stop.
When the switch is turned ON, the fan does not begin to operate.	Heating preparations underway	After the switch is turned to ON or until the piping temperature reaches 35°C, there will be 5 minutes of light air operation. After that there will be 2 minutes of low air operation, then set notch will begin (hot adjustment control).
The outdoor-side fan turns in reverse or stops, and an unusual sound is heard.	Ordinary display	There is a risk of the power to the unit being connected in reverse phase. Be sure to check that the phase is correct.

- Note:**
If indoor-side fan does not operate, check the over-current relay on the fan motor to determine whether it has been tripped.
If the over-current relay has been tripped, reset it after eliminating the cause of the problem (e.g. motor lock).
To reset the over-current relay, open the control box and press the green claw on bottom-right of the relay until a click is heard. Release the claw and check that it returns to its original position.
Note that if it is pressed too hard it will not return to its original position.

14. System control

14.1. System settings

[Fig. 14.1.1] (P.5)

- Ⓐ Unit
- Ⓑ Main remote controller
- Ⓒ Subordinate remote controller
- Ⓓ Refrigerant address = 00
- Ⓔ Refrigerant address = 01
- Ⓕ Refrigerant address = 02

* Set the refrigerant address using the DIP switch of the outdoor-side controller board.

① Wiring from the Remote Control

This wire is connected to TB5 (terminal board for remote controller) of the unit (non-polar).

② When a Different Refrigerant System Grouping is Used

Up to 16 refrigerant systems can be controlled as one group using the MA remote controller.

Note:

In single refrigerant system, there is no need of wiring ②.

SW1
Function table

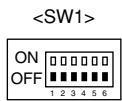

	Function	Operation according to switch setting	
		ON	OFF
SW1 function settings	1 Compulsory defrosting	Start	Normal
	2 Error history clear	Clear	Normal
	3 Refrigerant system address setting	Settings for outdoor unit addresses 0 to 15	
	4		
	5		
	6		

14.2. Examples of refrigerant system address setting

Ex.	Unit	Unit	Unit refrigerant system address	Remote controller power supply unit
1	PRH-P200-250MYA	-	00	○

* Set the refrigerant system address of one unit to 00 for the power supply to the remote controller.

(The refrigerant system address is set to 00 when shipped from the factory.)
Do not duplicate the refrigerant system address settings within the same system.

This product is designed and intended for use in the residential, commercial and light-industrial environment.

The product at hand is based on the following EU regulations:

- Low Voltage Directive 73/23/EEC
- Electromagnetic Compatibility Directive 89/336/EEC

Please be sure to put the contact address/telephone number on this manual before handing it to the customer.