

July 2013

No.OCB415

REVISED EDITION-G

PARTS CATALOG

R410A

Outdoor unit
[Model names]

PUHZ-P100VHA2
PUHZ-P125VHA2
PUHZ-P140VHA2
PUHZ-P100VHA3
PUHZ-P125VHA3
PUHZ-P140VHA3
PUHZ-P100VHA4
PUHZ-P100YHA
PUHZ-P100YHA2
PUHZ-P125YHA
PUHZ-P140YHA

[Service Ref.]
Refer to page 2.

Revision:

- PUHZ-P100YHA2R1.UK has been added in REVISED EDITION-G.
- Some descriptions have been modified.

- Please void OCB415 REVISED EDITION-F.

Note:

- RoHS compliant products have <G> mark on the spec name plate.

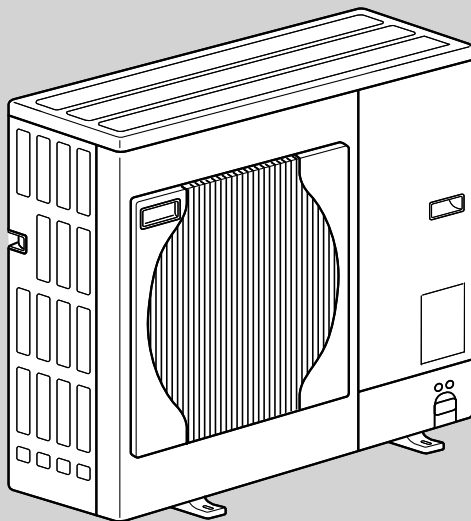

PUHZ-P100VHA4.UK
PUHZ-P100YHA2.UK

CONTENTS

1. RoHS PARTS LIST..... 2

SERVICE MANUAL (OCH415)



[Service Ref.]

PUHZ-P100VHA2.UK
PUHZ-P125VHA2.UK
PUHZ-P125VHA2i.UK
PUHZ-P140VHA2.UK
PUHZ-P140VHA2i.UK
PUHZ-P100VHA3.UK
PUHZ-P100VHA3R1.UK
PUHZ-P100VHA3R2.UK
PUHZ-P100VHA4.UK
PUHZ-P125VHA3.UK
PUHZ-P125VHA3R1.UK
PUHZ-P125VHA3R2.UK
PUHZ-P125VHA3R3.UK
PUHZ-P140VHA3.UK
PUHZ-P140VHA3R1.UK
PUHZ-P140VHA3R2.UK
PUHZ-P140VHA3R3.UK

PUHZ-P100YHA.UK
PUHZ-P100YHAR1.UK
PUHZ-P100YHA2.UK
PUHZ-P100YHA2R1.UK
PUHZ-P125YHA.UK
PUHZ-P125YHAR1.UK
PUHZ-P125YHAR2.UK
PUHZ-P140YHA.UK
PUHZ-P140YHAR1.UK
PUHZ-P140YHAR2.UK

1

RoHS PARTS LIST

STRUCTURAL PARTS
PUHZ-P100VHA2.UK
PUHZ-P100VHA3.UK

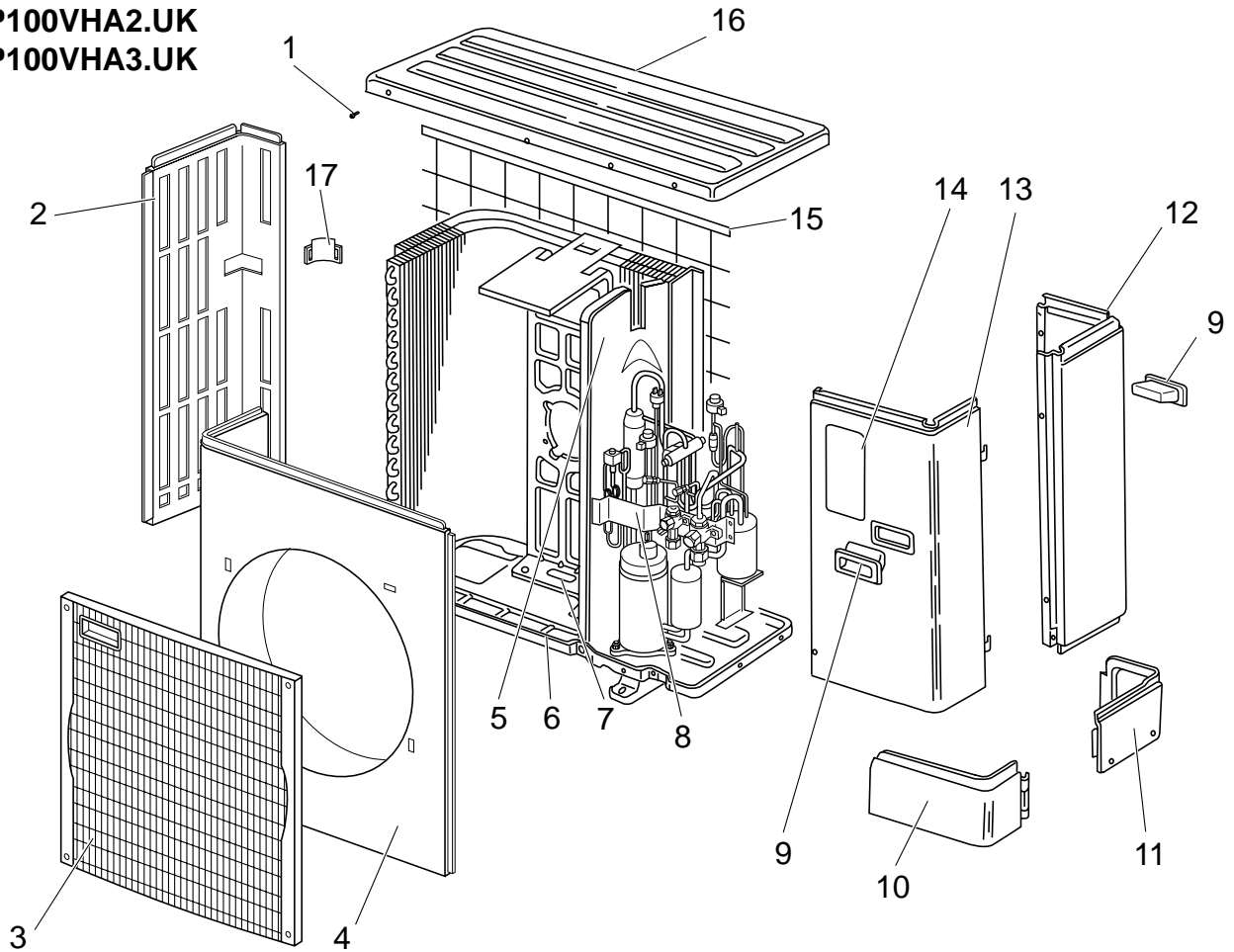

No.	RoHS	Part No.	Part Name	Specification	Q'ty/unit		Remarks (Drawing No.)	Wiring Diagram Symbol	Recom- mended Q'ty
					PUHZ-P				
					100				
		VHA2.UK	VHA3.UK						
1	G	—	F.ST SCREW	(5x12)	31	31	(DG12F536H12)		
2	G	S70 E10 662	SIDE PANEL (L)		1	1			
3	G	S70 E20 675	FAN GRILLE		1	1			
4	G	S70 E10 668	FRONT PANEL		1	1			
5	G	—	SEPARATOR		1	1	(BK00C456G03)		
6	G	S70 E10 686	BASE ASSY		1	1			
7	G	S70 E10 130	MOTOR SUPPORT		1	1			
8	G	—	VALVE BED ASSY		1	1	(BK00C493G01)		
9	G	S70 30L 655	HANDLE		2	2			
10	G	S70 E10 658	COVER PANEL (FRONT)		1	1			
11	G	S70 E20 658	COVER PANEL (REAR)		1	1			
12	G	S70 E60 662	SIDE PANEL (R)		1	1			
13	G	S70 E30 661	SERVICE PANEL		1	1			
14	G	S70 E10 699	LABEL		1	1			
15	G	S70 E10 698	REAR GUARD		1	1			
16	G	S70 E10 641	TOP PANEL		1	1			
17	G	S70 E10 655	HANDLE		1	1			

RoHS PARTS LIST

STRUCTURAL PARTS

PUHZ-P100VHA3R1.UK
 PUHZ-P100VHA3R2.UK
 PUHZ-P100VHA4.UK
 PUHZ-P100YHA.UK
 PUHZ-P100YHAR1.UK
 PUHZ-P100YHA2.UK
 PUHZ-P100YHA2R1.UK

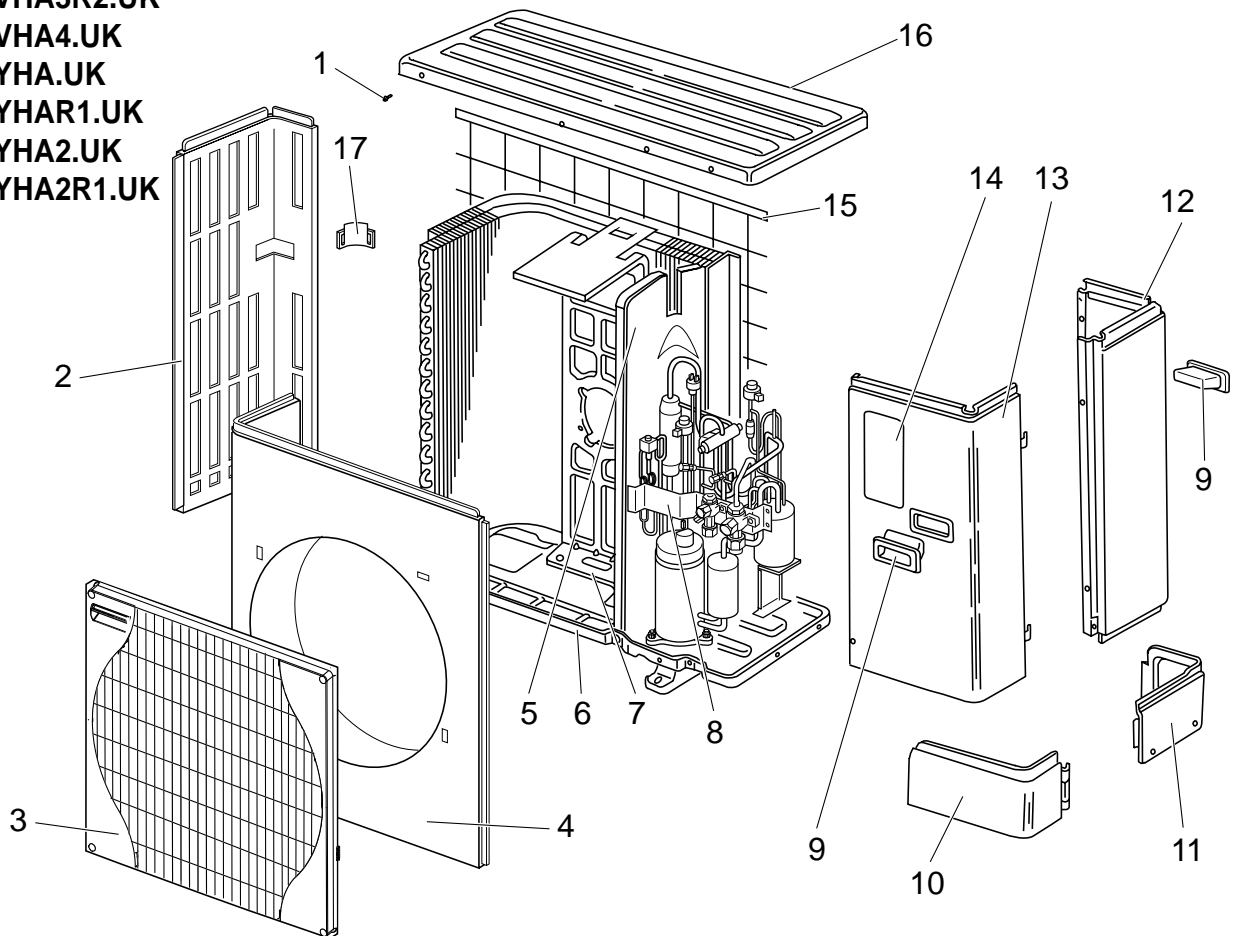

No.	RoHS	Part No.	Part Name	Specification	Q'ty/unit					Remarks (Drawing No.)	Wiring Diagram Symbol
					PUHZ-P100						
					VHA3		VHA4.UK	YHA.UK	YHA2.UK		
R1.UK	R2.UK		YHAR1.UK	YHA2R1.UK							
1	G	—	F.ST SCREW	(5x12)	31	31	31	31	31	(DG12F536H12)	
2	G	S70 E11 662	SIDE PANEL (L)		1	1	1	1	1		
3	G	S70 E30 675	FAN GRILLE		1	1	1	1	1		
4	G	S70 E30 668	FRONT PANEL		1	1	1	1	1		
5	G	—	SEPARATOR		1	1				(BK00C456G29)	
	G	—	SEPARATOR					1		(BK00C456G30)	
	G	—	SEPARATOR				1			(BK00C456G44)	
	G	—	SEPARATOR						1	(BK00C456G45)	
6	G	S70 E11 686	BASE ASSY		1	1	1	1	1		
7	G	S70 E10 130	MOTOR SUPPORT		1	1	1	1	1		
8	G	S71 0VB 001	VALVE BED ASSY		1	1	1	1	1		
9	G	S70 30L 655	HANDLE		2	2	2	2	2		
10	G	S70 E30 658	COVER PANEL (FRONT)		1	1	1	1	1		
11	G	S70 E40 658	COVER PANEL (REAR)		1	1	1	1	1		
12	G	S70 E51 662	SIDE PANEL (R)		1	1		1			
	G	S70 E60 662	SIDE PANEL (R)				1		1		
13	G	S70 E50 661	SERVICE PANEL		1						
	G	S70 E80 661	SERVICE PANEL			1	1	1	1		
14	G	S70 E10 699	LABEL		1	1	1	1	1		
15	G	S70 E10 698	REAR GUARD		1	1	1	1	1		
16	G	S70 E20 641	TOP PANEL		1	1	1	1	1		
17	G	S70 E10 655	HANDLE		1	1	1	1	1		

RoHS PARTS LIST

STRUCTURAL PARTS

PUHZ-P125VHA2.UK
 PUHZ-P140VHA2.UK
 PUHZ-P125VHA2i.UK
 PUHZ-P140VHA2i.UK
 PUHZ-P125VHA3.UK
 PUHZ-P140VHA3.UK

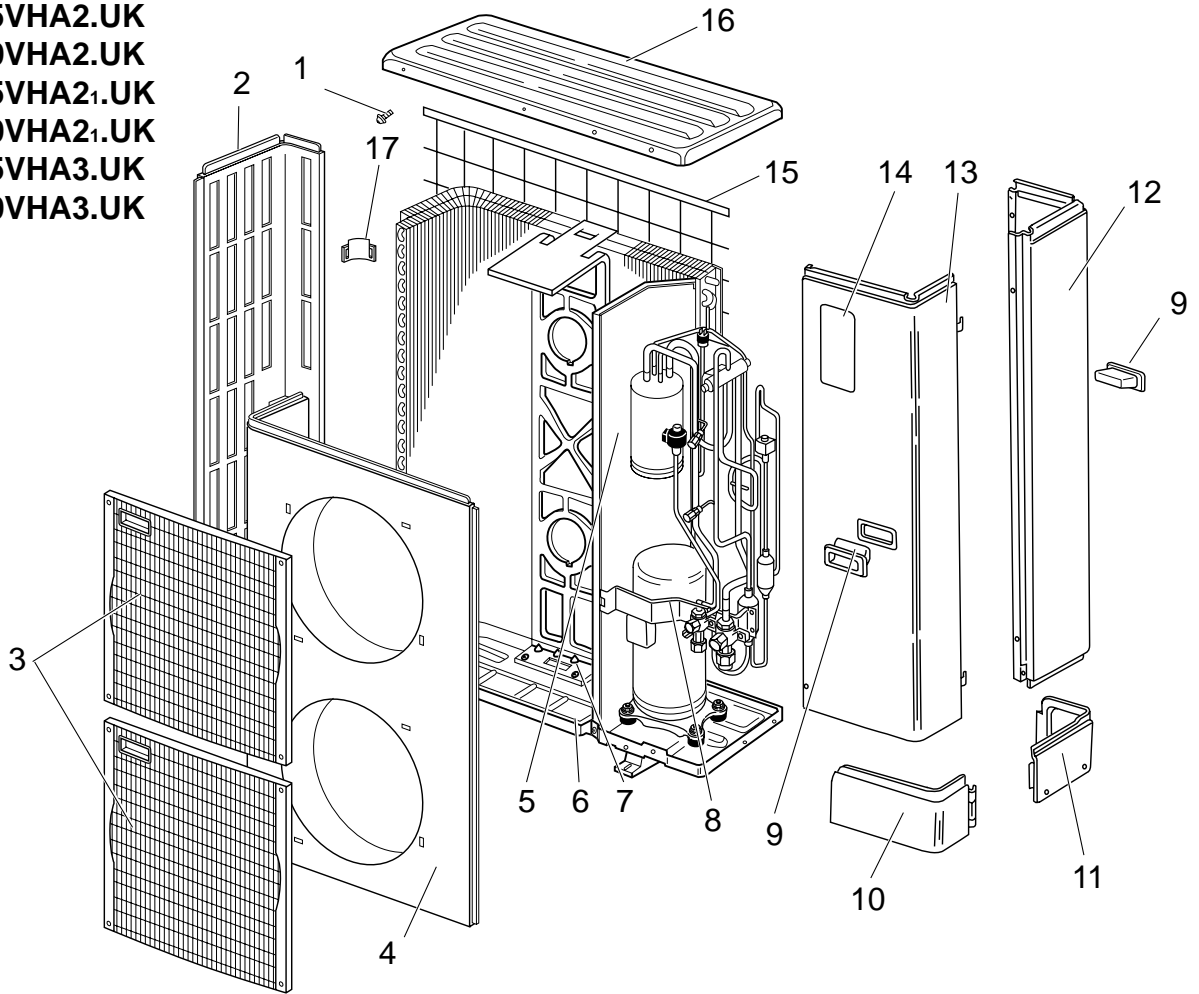

No.	RoHS	Part No.	Part Name	Specification	Q'ty/unit		Remarks (Drawing No.)	Wiring Diagram Symbol	Recom- mended Q'ty
					PUHZ-P 125, 140				
					VHA2.UK VHA2i.UK	VHA3.UK			
1	G	—	F.ST SCREW	(5×12)	46	46	(DG12F536H12)		
2	G	S70 E20 662	SIDE PANEL (L)		1	1			
3	G	S70 E20 675	FAN GRILLE		2	2			
4	G	S70 E20 668	FRONT PANEL		1	1			
5	G	—	SEPARATOR		1	1	(BK00C456G53)		
6	G	S70 E10 686	BASE ASSY		1	1			
7	G	S70 E20 130	MOTOR SUPPORT		1	1			
8	G	—	VALVE BED ASSY		1	1	(BK00C493G01)		
9	G	S70 30L 655	HANDLE		2	2			
10	G	S70 E10 658	COVER PANEL (FRONT)		1	1			
11	G	S70 E20 658	COVER PANEL (REAR)		1	1			
12	G	S70 E50 662	SIDE PANEL (R)		1	1			
13	G	S70 E40 661	SERVICE PANEL		1	1			
14	G	S70 E10 699	LABEL		1	1			
15	G	S70 E20 698	REAR GUARD		2	2			
16	G	S70 E10 641	TOP PANEL		1	1			
17	G	S70 E10 655	HANDLE		1	1			

RoHS PARTS LIST

STRUCTURAL PARTS

PUHZ-P125VHA3R1.UK

PUHZ-P140VHA3R1.UK

PUHZ-P125VHA3R2.UK

PUHZ-P140VHA3R2.UK

PUHZ-P125VHA3R3.UK

PUHZ-P140VHA3R3.UK

PUHZ-P125YHA.UK

PUHZ-P140YHA.UK

PUHZ-P125YHAR1.UK

PUHZ-P140YHAR1.UK

PUHZ-P125YHAR2.UK

PUHZ-P140YHAR2.UK

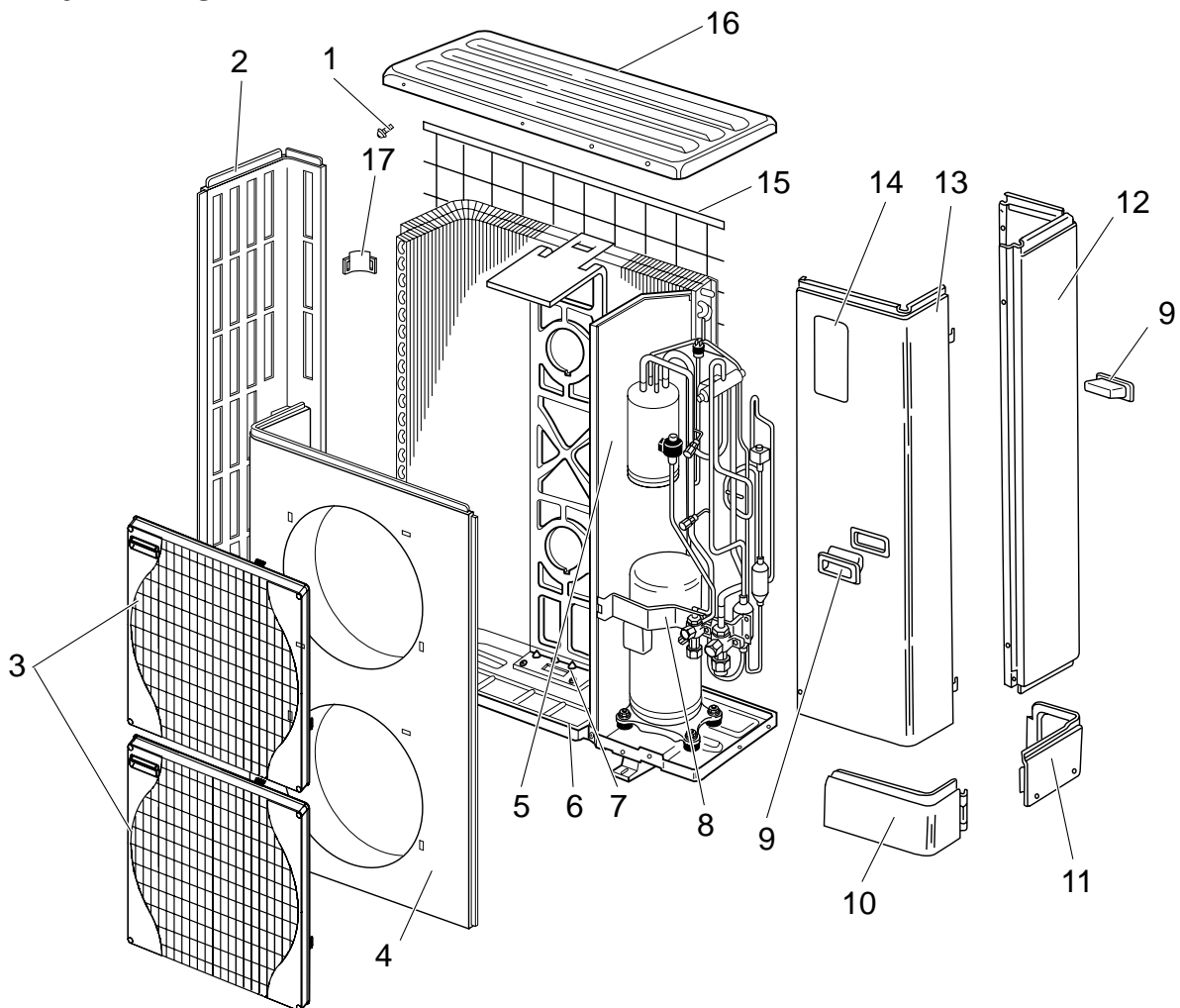

RoHS PARTS LIST

No.	RoHS	Part No.	Part Name	Specification	Q'ty/unit				Remarks (Drawing No.)	Wiring Diagram Symbol
					PUHZ-P125,140					
					VHA3R1.UK VHA3R2.UK YHAR.UK	VHA3R3.UK	YHAR1.UK	YHAR2.UK		
1	G	—	F.ST SCREW	(5x12)	46	46	46	46	(DG12F536H12)	
2	G	S70 E21 662	SIDE PANEL (L)		1	1	1	1		
3	G	S70 E30 675	FAN GRILLE		2	2	2	2		
4	G	S70 E40 668	FRONT PANEL		1	1	1	1		
5	G	—	SEPARATOR		1				(BK00C456G28)	
	G	—	SEPARATOR				1		(BK00C456G33)	
	G	—	SEPARATOR			1		1	(BK00C456G53)	
6	G	S70 E11 686	BASE ASSY		1	1	1	1		
7	G	S70 E20 130	MOTOR SUPPORT		1	1	1	1		
8	G	S71 0VB 001	VALVE BED ASSY		1	1	1	1		
9	G	S70 30L 655	HANDLE		2	2	2	2		
10	G	S70 E30 658	COVER PANEL (FRONT)		1	1	1	1		
11	G	S70 E40 658	COVER PANEL (REAR)		1	1	1	1		
12	G	S70 E61 662	SIDE PANEL (R)		1	1	1	1		
13	G	S70 E60 661	SERVICE PANEL		1	1	1	1		
14	G	S70 E10 699	LABEL		1	1	1	1		
15	G	S70 E20 698	REAR GUARD		2	2	2	2		
16	G	S70 E20 641	TOP PANEL		1	1	1	1		
17	G	S70 E10 655	HANDLE		1	1	1	1		

RoHS PARTS LIST

FUNCTIONAL PARTS
PUHZ-P100VHA2.UK
PUHZ-P100VHA3.UK

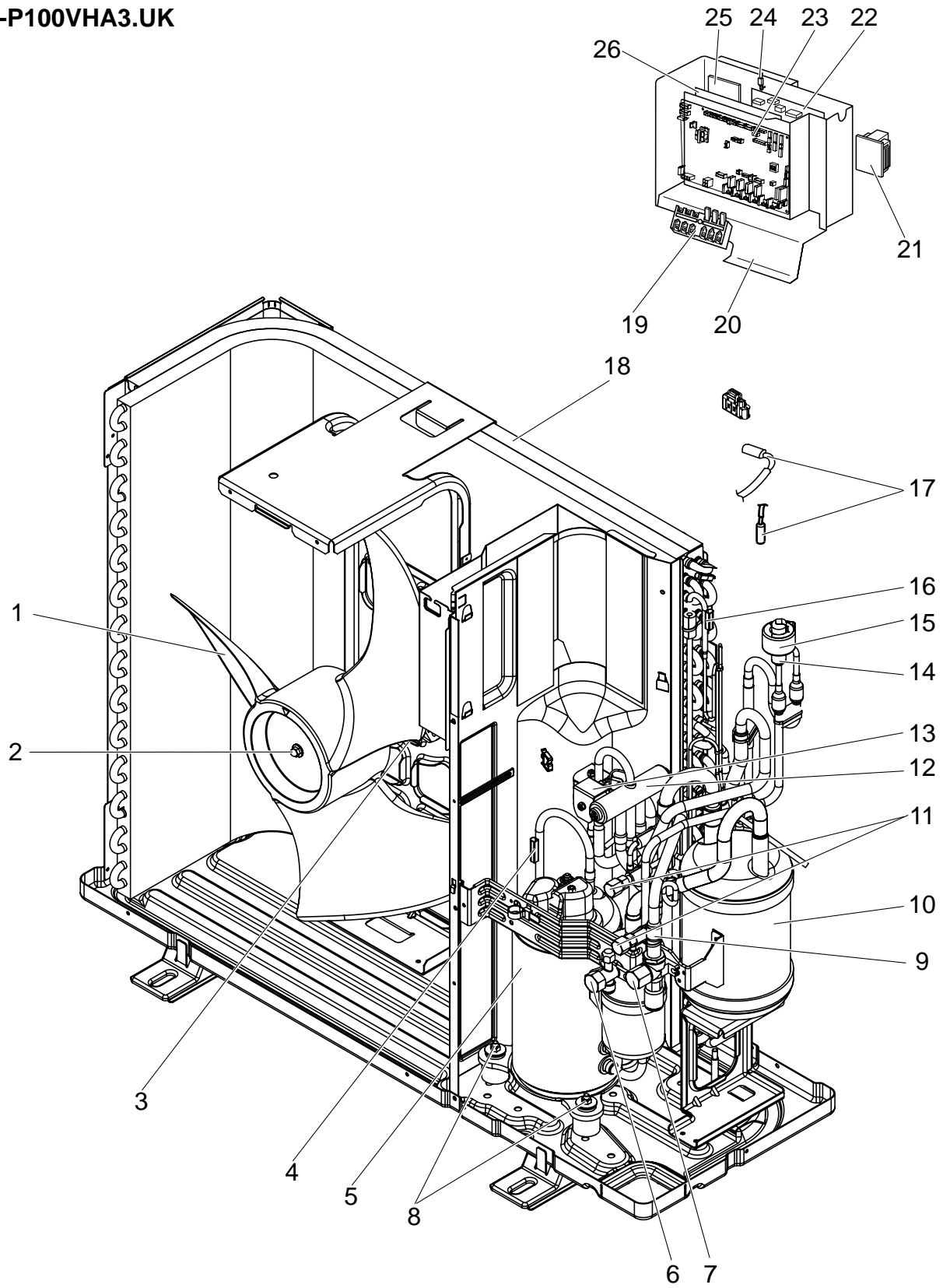

RoHS PARTS LIST

Part numbers that are circled are not shown in the figures.

No.	RoHS	Part No.	Part Name	Specification	Q'ty/unit		Remarks (Drawing No.)	Wiring Diagram Symbol	Recom- mended Q'ty
					PUHZ-P100				
					VHA2.UK	VHA3.UK			
1	G	S70 K04 115	PROPELLER FAN		1	1			
2	G	S70 K01 097	NUT		1	1			
3	G	S70 E10 763	FAN MOTOR		1	1		MF1	
4	G	S70 E33 202	THERMISTOR (DISCHARGE)		1	1		TH4	
5	G	S70 E41 400	COMPRESSOR	TNB220FLBM	1	1		MC	
6	G	S70 500 418	STOP VALVE	3/8	1	1			
7	G	S70 E07 411	STOP VALVE	5/8	1	1			
8	G	S70 E01 004	RUBBER MOUNT		3	3			
9	G	S70 36L 450	STRAINER	#50	1	1			
10	G	S70 E50 440	ACCUMULATOR		1	1			
11	G	S70 E02 413	CHARGE PLUG		2	2			
12	G	S70 E04 403	4-WAY VALVE		1	1			
13	G	S70 E01 242	SOLENOID VALVE COIL <4-WAY VALVE>		1	1		21S4	
14	G	S70 E80 401	EXPANSION VALVE		1	1			
15	G	S70 E81 402	LINEAR EXPANSION VALVE COIL		1	1		LEV-A	
16	G	S70 E32 202	THERMISTOR (OUTDOOR PIPE)		1	1		TH3	
17	G	S70 E31 202	THERMISTOR (OUTDOOR 2-PHASE PIPE, OUTDOOR)		1	1		TH6, 7	
18	G	S70 E50 408	HEAT EXCHANGER		1	1			
19	G	S70 E05 716	TERMINAL BLOCK	6P (L,N,⊙,S1,S2,S3)	1	1		TB1	
20	G	S70 E10 316	CONTROL BOX ASSY		1				
	G	S70 E34 316	CONTROL BOX ASSY			1			
21	G	S70 K20 259	REACTOR		1	1		DCL	
22	G	S70 0B2 313	POWER CIRUIT BOARD		1	1		P.B.	
23	G	S70 0B5 315	CONTROLLER CIRCUIT BOARD		1	1		C.B.	
24	G	S70 E30 202	THERMISTOR (HEATSINK)		1	1		TH8	
25	G	S70 E20 233	ACTIVE FILTER MODULE		1	1		ACTM	
26	G	S70 E20 346	NOISE FILTER CIRCUIT BOARD		1	1		N.F.	
27	G	S70 E10 208	HIGH PRESSURE SWITCH	OFF 4.14MPa	1	1		63H	
28	G	S70 42H 467	MUFFLER		1	1			
29	G	S70 E05 255	MAIN SMOOTHING CAPACITOR		1	1		CB	

RoHS PARTS LIST

FUNCTIONAL PARTS
PUHZ-P100VHA3R1.UK
PUHZ-P100YHA.UK

PUHZ-P100VHA3R2.UK
PUHZ-P100YHAR1.UK

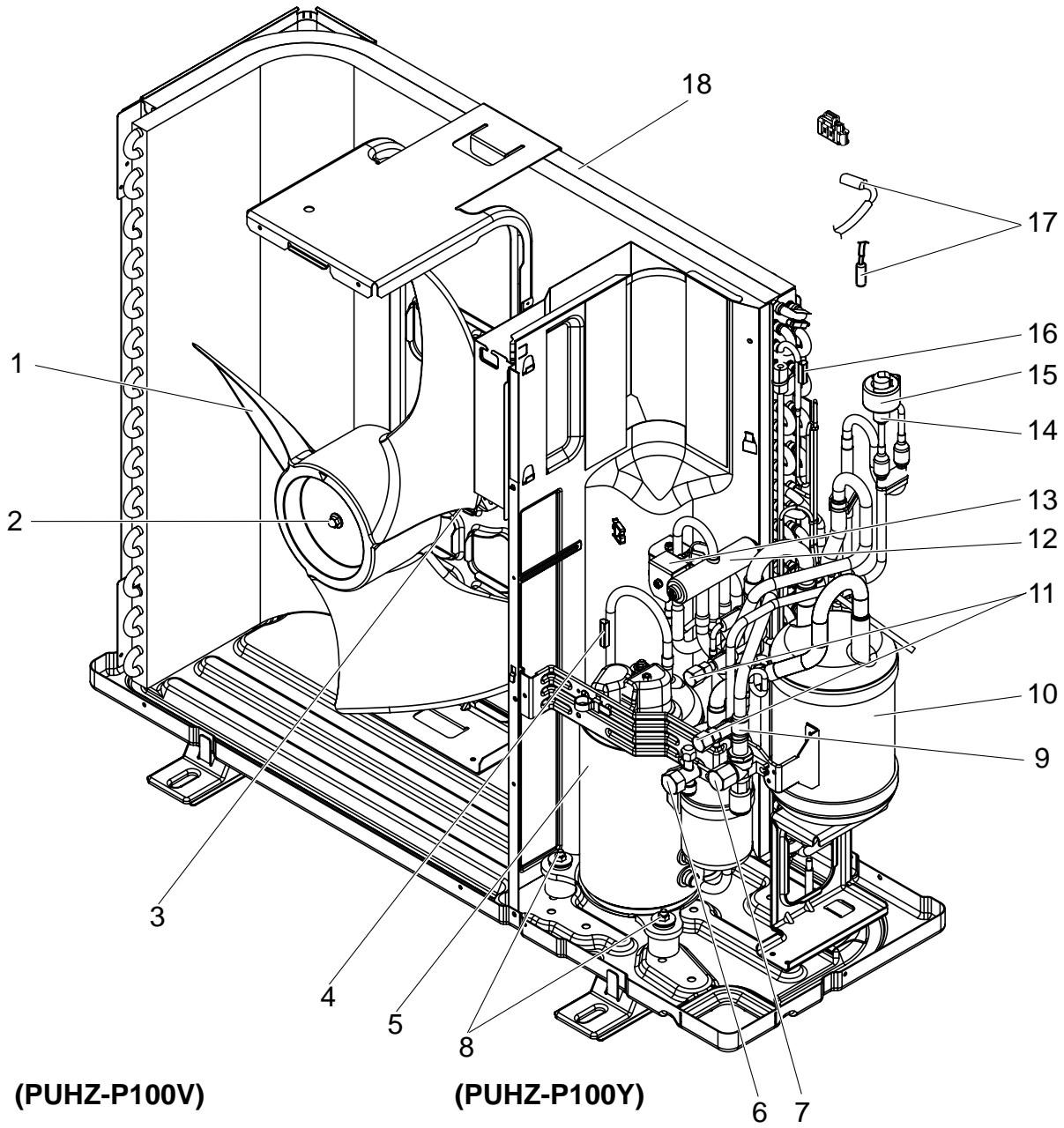

(PUHZ-P100V)

(PUHZ-P100Y)

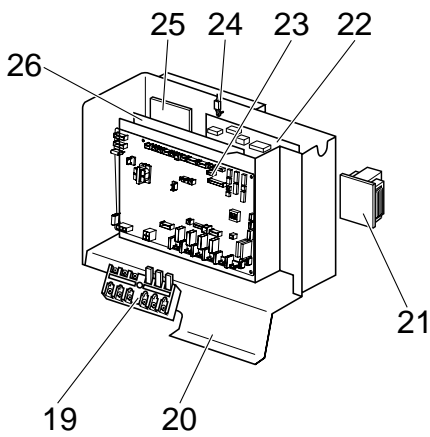

OCB415G

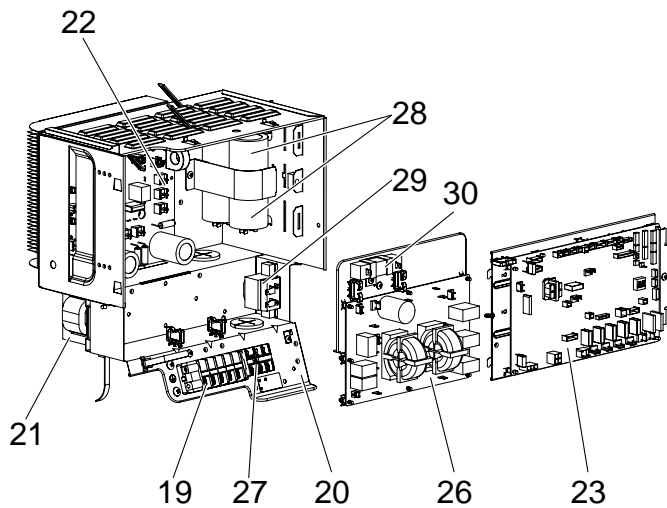

10

RoHS PARTS LIST

Part numbers that are circled are not shown in the figures.

No.	RoHS	Part No.	Part Name	Specification	Q'ty/unit				Remarks (Drawing No.)	Wiring Diagram Symbol	Recommended Q'ty
					PUHZ-P100						
					VHA3		YHA	YHAR1			
R1.UK	R2.UK	.UK	.UK								
1	G	S70 K04 115	PROPELLER FAN		1	1	1	1			
2	G	S70 K01 097	NUT		1	1	1	1			
3	G	S70 E10 763	FAN MOTOR		1	1	1	1		MF1	
4	G	S70 E33 202	THERMISTOR (DISCHARGE)		1					TH4	
5	G	S70 E41 400	COMPRESSOR	TNB220FLHMT	1	1				MC	
	G	S70 E43 400	COMPRESSOR	TNB220FLCMT			1	1		MC	
6	G	S70 600 418	STOP VALVE	3/8	1	1	1	1			
7	G	S70 E07 411	STOP VALVE	5/8	1	1	1	1			
8	G	S70 E01 004	RUBBER MOUNT		3	3	3	3			
9	G	S70 36L 450	STRAINER	#50	1	1	1	1			
10	G	S70 E10 440	ACCUMULATOR		1	1	1	1			
11	G	S70 E02 413	CHARGE PLUG		2	2	2	2			
12	G	S70 E04 403	4-WAY VALVE		1	1	1	1			
13	G	S70 E01 242	SOLENOID VALVE COIL <4-WAY VALVE>		1	1	1	1		21S4	
14	G	S70 E80 401	EXPANSION VALVE		1	1	1	1			
15	G	S70 E81 402	LINEAR EXPANSION VALVE COIL		1	1	1	1		LEV-A	
16	G	S70 E32 202	THERMISTOR (OUTDOOR PIPE)		1					TH3	
	G	S70 E47 202	THERMISTOR (OUTDOOR PIPE)			1	1	1		TH3	
17	G	S70 E31 202	THERMISTOR (OUTDOOR 2-PHASE PIPE, OUTDOOR)		1	1	1	1		TH6, 7	
18	G	S70 E50 408	HEAT EXCHANGER		1	1	1	1			
19	G	S70 E05 716	TERMINAL BLOCK	6P (L,N,⊙,S1,S2,S3)	1	1				TB1	
	G	S70 E09 716	TERMINAL BLOCK	5P (L1,L2,L3,N,⊙)			1	1		TB1	
20	G	S70 E34 316	CONTROL BOX ASSY		1						
	G	S70 E38 316	CONTROL BOX ASSY			1					
	G	S70 E42 316	CONTROL BOX ASSY				1				
	G	S70 E45 316	CONTROL BOX ASSY					1			
21	G	S70 K20 259	REACTOR		1					DCL	
	G	S70 K40 259	REACTOR			1				DCL	
	G	S70 K50 259	REACTOR				1	1		DCL	
22	G	S70 0B2 313	POWER CIRCUIT BOARD		1					P.B.	
	G	S70 0B5 313	POWER CIRCUIT BOARD			1				P.B.	
	G	S70 0B7 313	POWER CIRCUIT BOARD				1			P.B.	
	G	S70 0B8 313	POWER CIRCUIT BOARD					1		P.B.	
23	G	S70 0B5 315	CONTROLLER CIRCUIT BOARD		1					C.B.	
	G	S70 0B8 315	CONTROLLER CIRCUIT BOARD			1	1	1		C.B.	
24	G	S70 E30 202	THERMISTOR (HEATSINK)		1					TH8	
25	G	S70 E20 233	ACTIVE FILTER MODULE		1					ACTM	
26	G	S70 E20 346	NOISE FILTER CIRCUIT BOARD		1					N.F.	
	G	S70 E30 346	NOISE FILTER CIRCUIT BOARD				1	1		N.F.	
27	G	S70 E08 716	TERMINAL BLOCK	3P (S1,S2,S3)			1	1		TB2	
28	G	S70 E61 255	MAIN SMOOTHING CAPACITOR				2	2		CB1,2	
29	G	S70 K90 259	REACTOR				1	1		ACL4	
30	G	S70 E20 234	RESISTOR				1	1		RS	
31	G	S70 E10 208	HIGH PRESSURE SWITCH	OFF 4.14MPa	1	1	1	1		63H	
32	G	S70 42H 467	MUFFLER		1	1	1	1			
33	G	S70 E45 202	THERMISTOR (COMP.SURFACE)			1	1	1		TH32	
34	G	S70 E05 255	MAIN SMOOTHING CAPACITOR		1	1				CB	

RoHS PARTS LIST

FUNCTIONAL PARTS
 PUHZ-P100VHA4.UK
 PUHZ-P100YHA2.UK
 PUHZ-P100YHA2R1.UK

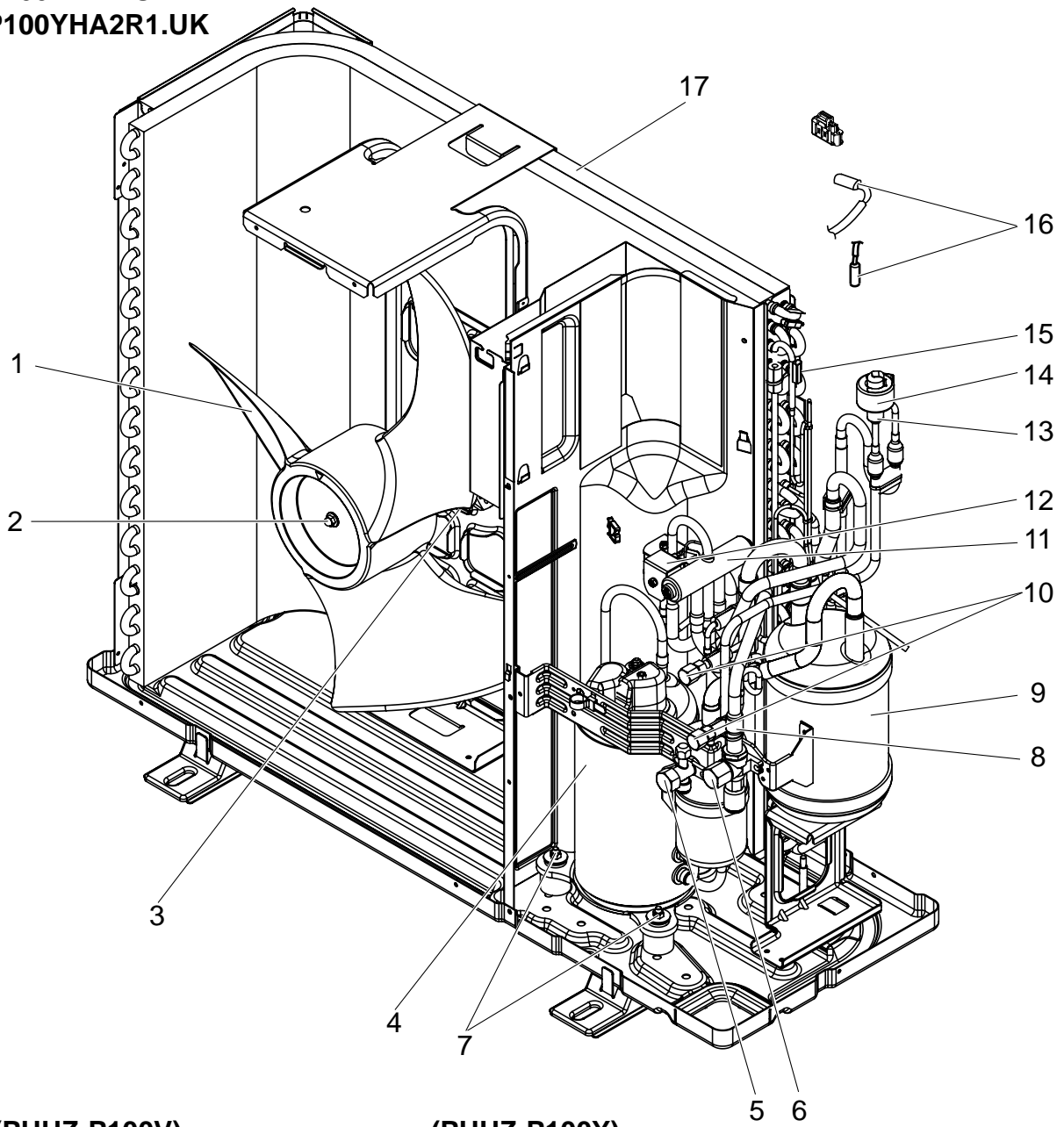

(PUHZ-P100V)

(PUHZ-P100Y)

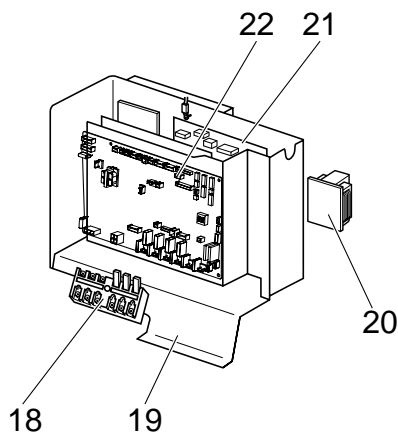

OCB415G

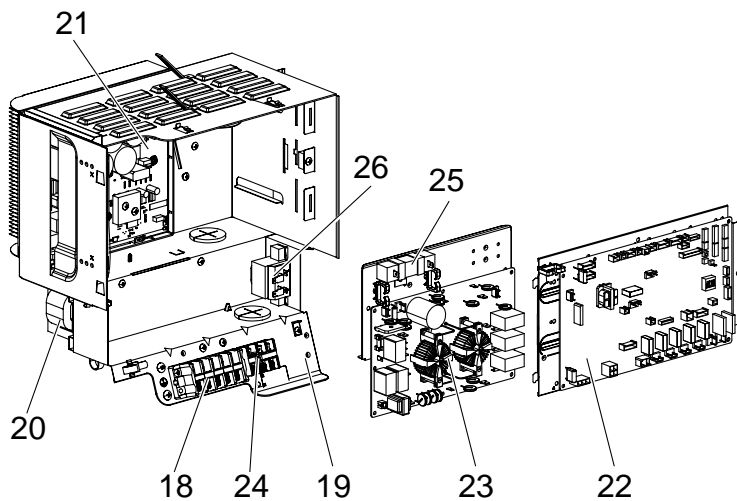

12

RoHS PARTS LIST

Part numbers that are circled are not shown in the figures.

No.	RoHS	Part No.	Part Name	Specification	Q'ty/unit			Remarks (Drawing No.)	Wiring Diagram Symbol
					PUHZ-P100				
					VHA4.UK	YHA2.UK	YHA2R1.UK		
1	G	S70 K04 115	PROPELLER FAN		1	1	1		
2	G	S70 K01 097	NUT		1	1	1		
3	G	S70 E10 763	FAN MOTOR		1	1	1		MF1
4	G	S70 E41 400	COMPRESSOR	TNB220FLHMT	1				MC
	G	S70 E43 400	COMPRESSOR	TNB220FLCMT		1	1		MC
5	G	S70 600 418	STOP VALVE	3/8	1	1	1		
6	G	S70 E07 411	STOP VALVE	5/8	1	1	1		
7	G	S70 E01 004	RUBBER MOUNT		3	3	3		
8	G	S70 36L 450	STRAINER	#50	1	1	1		
9	G	S70 E10 440	ACCUMULATOR		1	1	1		
10	G	S70 E02 413	CHARGE PLUG		2	2	2		
11	G	S70 E04 403	4-WAY VALVE		1	1	1		
12	G	S70 E01 242	SOLENOID VALVE COIL <4-WAY VALVE>		1	1	1		21S4
13	G	S70 E80 401	EXPANSION VALVE		1	1	1		
14	G	S70 E81 402	LINEAR EXPANSION VALVE COIL		1	1	1		LEV-A
15	G	S70 E47 202	THERMISTOR (LIQUID)		1	1	1		TH3
16	G	S70 E31 202	THERMISTOR (2-PHASE PIPE, AMBIENT)		1	1	1		TH6, 7
17	G	S70 E50 408	HEAT EXCHANGER		1	1	1		
18	G	S70 C20 515	TERMINAL BLOCK	6P (L,N,⊕,S1,S2,S3)	1				TB1
	G	S70 E09 716	TERMINAL BLOCK	5P (L1,L2,L3,N,⊕)		1	1		TB1
19	G	S70 E61 316	CONTROL BOX ASSY		1				
	G	S70 E71 316	CONTROL BOX ASSY			1			
	G	S70 E74 316	CONTROL BOX ASSY				1		
20	G	S70 K40 259	REACTOR		1				DCL
	G	S70 K50 259	REACTOR			1	1		DCL
21	G	S70 0B6 313	POWER CIRCUIT BOARD		1				P.B.
	G	S70 B10 313	POWER CIRCUIT BOARD			1			P.B.
	G	S70 B20 313	POWER CIRCUIT BOARD				1		P.B.
22	G	S70 B10 315	CONTROLLER CIRCUIT BOARD		1	1	1		C.B.
23	G	S70 E60 346	NOISE FILTER CIRCUIT BOARD			1	1		N.F.
24	G	S70 E08 716	TERMINAL BLOCK	3P (S1,S2,S3)		1	1		TB2
25	G	S70 E20 234	RESISTOR			1	1		RS
26	G	S70 K90 259	REACTOR			1	1		ACL4
27	G	S70 E55 202	THERMISTOR (HEATSINK)			1	1		TH8
28	G	S70 E10 208	HIGH PRESSURE SWITCH	OFF 4.14MPa	1	1	1		63H
29	G	S70 42H 467	MUFFLER		1	1	1		
30	G	S70 E45 202	THERMISTOR (COMP. SURFACE)		1	1	1		TH32
31	G	S70 E05 255	MAIN SMOOTHING CAPACITOR		1				CB

RoHS PARTS LIST

FUNCTIONAL PARTS

PUHZ-P125VHA2.UK

PUHZ-P125VHA2₁.UK

PUHZ-P125VHA3.UK

PUHZ-P140VHA2.UK

PUHZ-P140VHA2₁.UK

PUHZ-P140VHA3.UK

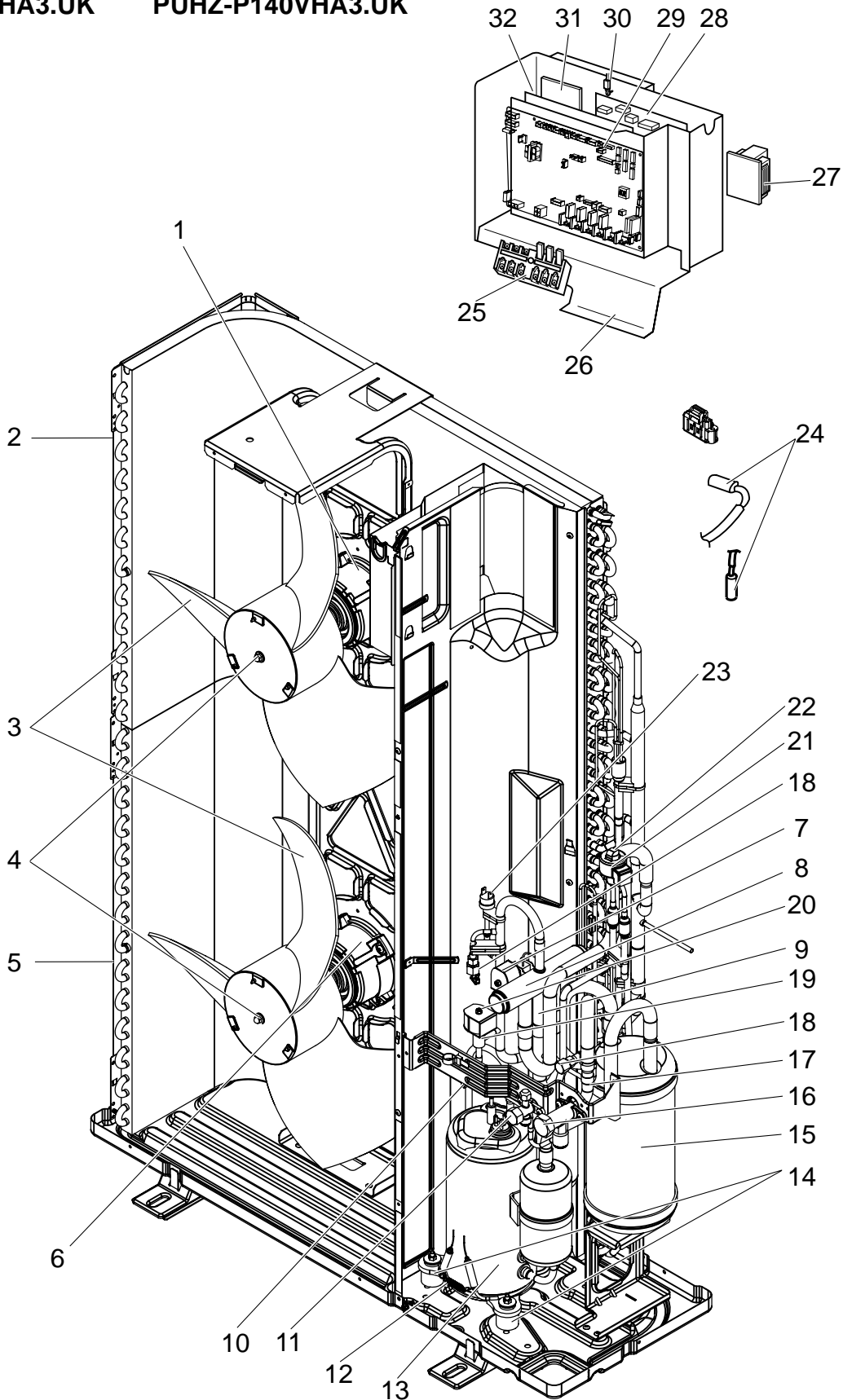

RoHS PARTS LIST

Part numbers that are circled are not shown in the figures.

No.	RoHS	Part No.	Part Name	Specification	Q'ty/unit						Remarks (Drawing No.)	Wiring Diagram Symbol	Recom- mended Q'ty
					PUHZ-P								
					125	140	125	140	125	140			
VHA2.UK		VHA2i.UK		VHA3.UK									
1	G	S70 E10 763	FAN MOTOR		1	1	1	1	1	1		MF1	
2	G	S70 R80 408	HEAT EXCHANGER (TOP)		1	1	1	1	1	1			
3	G	S70 K04 115	PROPELLER FAN		2	2	2	2	2	2			
4	G	S70 K01 097	NUT		2	2	2	2	2	2			
5	G	S70 R90 408	HEAT EXCHANGER(UNDER)		1	1	1	1	1	1			
6	G	S70 E20 763	FAN MOTOR		1	1	1	1	1	1		MF2	
7	G	S70 E44 242	SOLENOID COIL <4-WAY VALVE>		1	1						21S4	
	G	S70 E55 242	SOLENOID COIL <4-WAY VALVE>				1	1	1	1		21S4	
8	G	S70 E03 403	4-WAY VALVE		1	1							
	G	S70 E05 403	4-WAY VALVE				1	1	1	1			
9	G	S70 42H 467	MUFFLER		1	1	1	1	1	1			
10	G	S70 E36 202	THERMISTOR (DISCHARGE)		1	1	1	1	1	1		TH4	
11	G	S70 500 418	STOP VALVE	3/8	1	1	1	1	1	1			
12	G	S70 0B4 236	CRANKCASE HEATER		1	1	1	1	1	1		CH	
13	G	S70 E42 400	COMPRESSOR	TNB306FPGM	1	1	1	1	1	1		MC	
14	G	S70 E01 004	RUBBER MOUNT		3	3	3	3	3	3			
15	G	S70 E60 440	ACCUMULATOR		1	1	1	1	1	1			
16	G	S70 E07 411	STOP VALVE	5/8	1	1	1	1	1	1			
17	G	S70 36L 450	STRAINER	#50	1	1	1	1	1	1			
18	G	S70 E02 413	CHARGE PLUG		2	2	2	2	2	2			
19	G	S70 282 403	BYPASS VALVE		1	1	1	1	1	1			
20	G	S70 451 242	BYPASS VALVE COIL		1	1	1	1	1	1		SV	
21	G	S70 E81 402	LINEAR EXPANSION VALVE COIL		1	1	1	1	1	1		LEV-A	
22	G	S70 E90 401	EXPANSION VALVE		1	1	1	1	1	1			
23	G	S70 E10 208	HIGH PRESSURE SWITCH	OFF4.14MPa	1	1	1	1	1	1		63H	
24	G	S70 E31 202	THERMISTOR (OUTDOOR 2-PHASE PIPE, OUTDOOR)		1	1	1	1	1	1		TH6,7	
25	G	S70 E05 716	TERMINAL BLOCK	6P(L,N,⊙,S1,S2,S3)	1	1	1	1	1	1		TB1	
26	G	S70 E20 316	CONTROL BOX ASSY		1								
	G	S70 E30 316	CONTROL BOX ASSY			1							
	G	S70 E21 316	CONTROL BOX ASSY				1						
	G	S70 E31 316	CONTROL BOX ASSY					1					
	G	S70 E35 316	CONTROL BOX ASSY						1				
	G	S70 E36 316	CONTROL BOX ASSY							1			
27	G	S70 K20 259	REACTOR		1	1	1	1	1	1		DCL	
28	G	S70 0B3 313	POWER CIRCUIT BOARD		1	1	1	1	1	1		P.B.	
29	G	S70 0B5 315	CONTROLLER CIRCUIT BOARD		1	1	1	1	1	1		C.B.	
30	G	S70 E30 202	THERMISTOR (HEATSINK)		1	1	1	1	1	1		TH8	
31	G	S70 E20 233	ACTIVE FILTER MODULE		1	1	1	1	1	1		ACTM	
32	G	S70 E20 346	NOISE FILTER CIRCUIT BOARD		1	1	1	1	1	1		N.F.	
33	G	S70 E37 202	THERMISTOR (OUTDOOR PIPE)		1	1	1	1	1	1		TH3	
34	G	S70 E05 255	MAIN SMOOTHING CAPACITOR		1	1	1	1	1	1		CB	

RoHS PARTS LIST

FUNCTIONAL PARTS

PUHZ-P125VHA3R1.UK

PUHZ-P125VHA3R2.UK

PUHZ-P125VHA3R3.UK

PUHZ-P140VHA3R1.UK

PUHZ-P140VHA3R2.UK

PUHZ-P140VHA3R3.UK

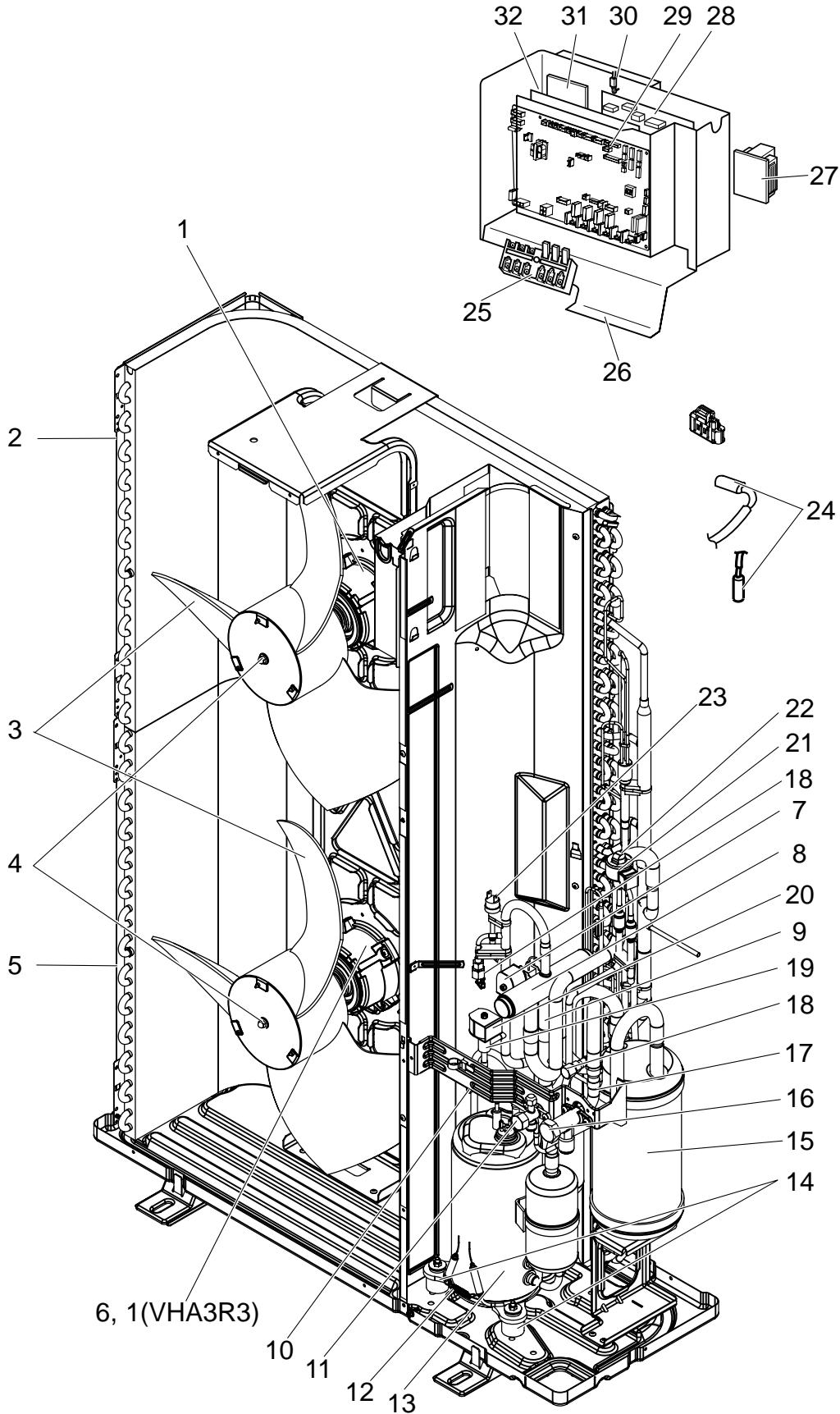

RoHS PARTS LIST

Part numbers that are circled are not shown in the figures.

No.	RoHS	Part No.	Part Name	Specification	Q'ty/unit						Remarks (Drawing No.)	Wiring Diagram Symbol
					PUHZ-P							
					125	140	125	140	125	140		
VHA3R1.UK		VHA3R2.UK		VHA3R3.UK								
1	G	S70 E10 763	FAN MOTOR		1	1	1	1	2	2		MF1(R1/R2) MF1, MF2(R3)
2	G	S70 R80 408	HEAT EXCHANGER (TOP)		1	1	1	1	1	1		
3	G	S70 K04 115	PROPELLER FAN		2	2	2	2	2	2		
4	G	S70 K01 097	NUT		2	2	2	2	2	2		
5	G	S70 R90 408	HEAT EXCHANGER (UNDER)		1	1	1	1	1	1		
6	G	S70 E20 763	FAN MOTOR		1	1	1	1				MF2
7	G	S70 E55 242	SOLENOID COIL (4-WAY VALVE)		1	1	1	1	1	1		21S4
8	G	S70 E05 403	4-WAY VALVE		1	1	1	1	1	1		
9	G	S70 42H 467	MUFFLER		1	1	1	1	1	1		
10	G	S70 E36 202	THERMISTOR (DISCHARGE)		1	1						TH4
11	G	S70 600 418	STOP VALVE	3/8	1	1	1	1	1	1		
12	G	S70 0B4 236	CRANKCASE HEATER		1	1	1	1	1	1		CH
13	G	S70 E42 400	COMPRESSOR	TNB306FPGM	1	1	1	1				MC
	G	S70 E92 400	COMPRESSOR	TNB306FPGMT					1	1		MC
14	G	S70 E01 004	RUBBER MOUNT		3	3	3	3	3	3		
15	G	S70 E11 440	ACCUMULATOR		1	1	1	1	1	1		
16	G	S70 E07 411	STOP VALVE	5/8	1	1	1	1	1	1		
17	G	S70 36L 450	STRAINER	#50	1	1	1	1	1	1		
18	G	S70 E02 413	CHARGE PLUG		2	2	2	2	2	2		
19	G	S70 282 403	BYPASS VALVE		1	1	1	1	1	1		
20	G	S70 451 242	BYPASS VALVE COIL		1	1	1	1	1	1		SV
21	G	S70 E81 402	LINEAR EXPANSION VALVE COIL		1	1	1	1	1	1		LEV-A
22	G	S70 E90 401	EXPANSION VALVE		1	1	1	1	1	1		
23	G	S70 E10 208	HIGH PRESSURE SWITCH	OFF 4.14MPa	1	1	1	1	1	1		63H
24	G	S70 E31 202	THERMISTOR (OUTDOOR 2-PHASE PIPE, AMBIENT)		1	1	1	1	1	1		TH6,7
25	G	S70 E05 716	TERMINAL BLOCK	6P(L,N,⊙,S1,S2,S3)	1	1	1	1				TB1
	G	S70 C20 515	TERMINAL BLOCK	6P(L,N,⊙,S1,S2,S3)					1	1		TB1
26	G	S70 E35 316	CONTROL BOX ASSY		1							
	G	S70 E36 316	CONTROL BOX ASSY			1						
	G	S70 E39 316	CONTROL BOX ASSY				1					
	G	S70 E41 316	CONTROL BOX ASSY					1				
	G	S70 E62 316	CONTROL BOX ASSY						1			
	G	S70 E63 316	CONTROL BOX ASSY							1		
27	G	S70 K20 259	REACTOR		1	1						DCL
	G	S70 K40 259	REACTOR				1	1	1	1		DCL
28	G	S70 0B3 313	POWER CIRCUIT BOARD		1	1						P.B.
	G	S70 0B6 313	POWER CIRCUIT BOARD				1	1	1	1		P.B.
29	G	S70 0B5 315	CONTROLLER CIRCUIT BOARD		1	1						C.B.
	G	S70 0B8 315	CONTROLLER CIRCUIT BOARD				1	1	1	1		C.B.
30	G	S70 E30 202	THERMISTOR (HEATSINK)		1	1						TH8
31	G	S70 E20 233	ACTIVE FILTER MODULE		1	1						ACTM
32	G	S70 E20 346	NOISE FILTER CIRCUIT BOARD		1	1						N.F.
33	G	S70 E46 202	THERMISTOR (COMP.SURFACE)				1	1	1	1		TH32
34	G	S70 E37 202	THERMISTOR (OUTDOOR PIPE)		1	1	1	1	1	1		TH3
35	G	S70 E05 255	MAIN SMOOTHING CAPACITOR		1	1	1	1	1	1		CB

RoHS PARTS LIST

FUNCTIONAL PARTS

PUHZ-P125YHA.UK

PUHZ-P140YHA.UK

PUHZ-P125YHAR1.UK

PUHZ-P140YHAR1.UK

PUHZ-P125YHAR2.UK

PUHZ-P140YHAR2.UK

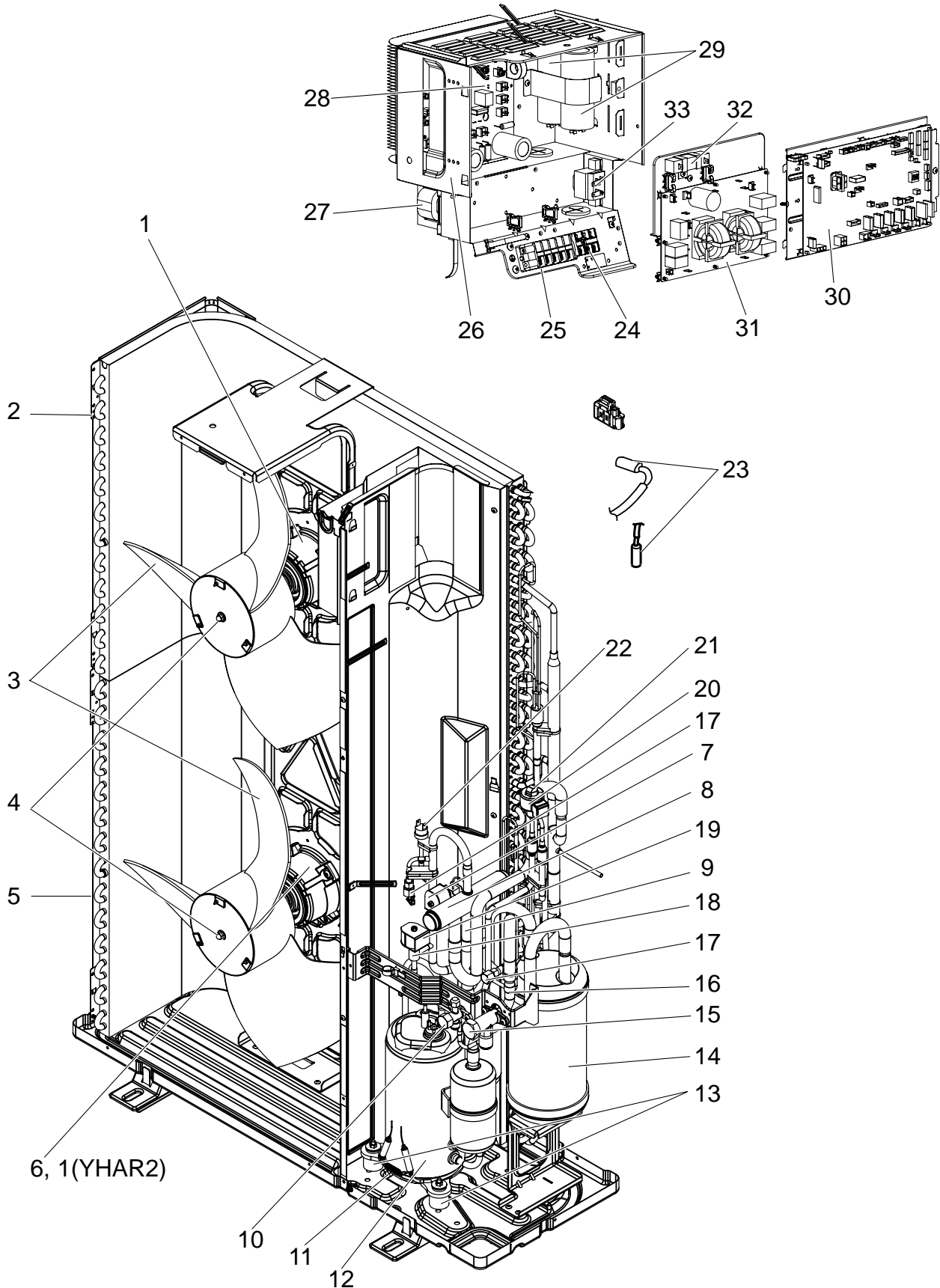

RoHS PARTS LIST

Part numbers that are circled are not shown in the figures.

No.	RoHS	Part No.	Part Name	Specification	Q'ty/unit						Remarks (Drawing No.)	Wiring Diagram Symbol
					PUHZ-P-YHA.UK		PUHZ-P-YHAR1.UK		PUHZ-P-YHAR2.UK			
					125	140	125	140	125	140		
1	G	S70 E10 763	FAN MOTOR		1	1	1	1	2	2		MF1(YHA(R1)) MF1, MF2(YHAR2)
2	G	S70 R80 408	HEAT EXCHANGER (TOP)		1	1	1	1	1	1		
3	G	S70 K04 115	PROPELLER FAN		2	2	2	2	2	2		
4	G	S70 K01 097	NUT		2	2	2	2	2	2		
5	G	S70 R90 408	HEAT EXCHANGER (UNDER)		1	1	1	1	1	1		
6	G	S70 E20 763	FAN MOTOR		1	1	1	1				MF2
7	G	S70 E55 242	SOLENOID COIL (4-WAY VALVE)		1	1	1	1	1	1		21S4
8	G	S70 E05 403	4-WAY VALVE		1	1	1	1	1	1		
9	G	S70 42H 467	MUFFLER		1	1	1	1	1	1		
10	G	S70 600 418	STOP VALVE	3/8	1	1	1	1	1	1		
11	G	S70 0B4 236	CRANKCASE HEATER		1	1	1	1	1	1		CH
12	G	S70 E44 400	COMPRESSOR	TNB306FPNM	1	1	1	1				MC
	G	S70 E93 400	COMPRESSOR	TNB306FPNMT					1	1		MC
13	G	S70 E01 004	RUBBER MOUNT		3	3	3	3	3	3		
14	G	S70 E11 440	ACCUMULATOR		1	1	1	1	1	1		
15	G	S70 E07 411	STOP VALVE	5/8	1	1	1	1	1	1		
16	G	S70 36L 450	STRAINER	#50	1	1	1	1	1	1		
17	G	S70 E02 413	CHARGE PLUG		2	2	2	2	2	2		
18	G	S70 282 403	BYPASS VALVE		1	1	1	1	1	1		
19	G	S70 451 242	BYPASS VALVE COIL		1	1	1	1	1	1		SV
20	G	S70 E81 402	LINEAR EXPANSION VALVE COIL		1	1	1	1	1	1		LEV-A
21	G	S70 E90 401	EXPANSION VALVE		1	1	1	1	1	1		
22	G	S70 E10 208	HIGH PRESSURE SWITCH	OFF 4.14MPa	1	1	1	1	1	1		63H
23	G	S70 E31 202	THERMISTOR (OUTDOOR 2-PHASE PIPE, AMBIENT)		1	1	1	1	1	1		TH6,7
24	G	S70 E08 716	TERMINAL BLOCK	3P (S1,S2,S3)	1	1	1	1	1	1		TB2
25	G	S70 E09 716	TERMINAL BLOCK	5P (L1,L2,L3,N,⊕)	1	1	1	1	1	1		TB1
26	G	S70 E43 316	CONTROL BOX ASSY		1							
	G	S70 E44 316	CONTROL BOX ASSY			1						
	G	S70 E46 316	CONTROL BOX ASSY				1					
	G	S70 E47 316	CONTROL BOX ASSY					1				
	G	S70 E72 316	CONTROL BOX ASSY						1			
	G	S70 E73 316	CONTROL BOX ASSY							1		
27	G	S70 K50 259	REACTOR		1	1	1	1	1	1		DCL
28	G	S70 0B7 313	POWER CIRCUIT BOARD		1	1						P.B.
	G	S70 0B8 313	POWER CIRCUIT BOARD				1	1	1	1		P.B.
29	G	S70 E61 255	MAIN SMOOTHING CAPACITOR		2	2	2	2	2	2		CB1,2
30	G	S70 0B8 315	CONTROLLER CIRCUIT BOARD		1	1	1	1	1	1		C.B.
31	G	S70 E30 346	NOISE FILTER CIRCUIT BOARD		1	1	1	1	1	1		N.F.
32	G	S70 E20 234	RESISTOR						1	1		RS
33	G	S70 K90 259	REACTOR						1	1		ACL4
35	G	S70 E37 202	THERMISTOR (OUTDOOR PIPE)		1	1	1	1	1	1		TH3
36	G	S70 E46 202	THERMISTOR (COMP.SURFACE)		1	1	1	1	1	1		TH32

Mr. SLIM™

mitsubishi electric corporation

HEAD OFFICE : TOKYO BLDG., 2-7-3, MARUNOUCHI, CHIYODA-KU, TOKYO 100-8310, JAPAN

©Copyright 2007 MITSUBISHI ELECTRIC CORPORATION
Distributed in Jul. 2013 No.OCB415 REVISED EDITION-G
Distributed in Dec. 2012 No.OCB415 REVISED EDITION-F
Distributed in Apr. 2010 No.OCB415 REVISED EDITION-E PDF 5
Distributed in Nov. 2009 No.OCB415 REVISED EDITION-D PDF 6
Distributed in Jul. 2009 No.OCB415 REVISED EDITION-C PDF 6
Distributed in Mar. 2009 No.OCB415 REVISED EDITION-B PDF 6
Distributed in Feb. 2008 No.OCB415 REVISED EDITION-A PDF 7
Distributed in Apr. 2007 No.OCB415 PDF 7
Made in Japan

New publication, effective Jul. 2013
Specifications are subject to change without notice.