

# Air-Conditioners PCA-RP·KA

## INSTALLATION MANUAL

For safe and correct use, read this manual and the outdoor unit installation manual thoroughly before installing the air-conditioner unit.

**FOR INSTALLER**

## INSTALLATIONSHANDBUCH

Aus Sicherheitsgründen und zur richtigen Anwendung vor Installation der Klimaanlage die vorliegende Bedienungsanleitung und das Installationshandbuch gründlich durchlesen.

**FÜR INSTALLATEURE**

## MANUEL D'INSTALLATION

Avant d'installer le climatiseur, lire attentivement ce manuel, ainsi que le manuel d'installation de l'appareil extérieur pour une utilisation sûre et correcte.

**POUR L'INSTALLATEUR**

## INSTALLATIEHANDLEIDING

Lees deze handleiding en de installatiehandleiding van het buitenapparaat zorgvuldig door voordat u met het installeren van de airconditioner begint.

**VOOR DE INSTALLATEUR**

## MANUAL DE INSTALACIÓN

Para un uso seguro y correcto, lea detalladamente este manual de instalación antes de montar la unidad de aire acondicionado.

**PARA EL INSTALADOR**

## MANUALE DI INSTALLAZIONE

Per un uso sicuro e corretto, prima di installare il condizionatore d'aria leggere attentamente il presente manuale ed il manuale d'installazione dell'unità esterna.

**PER L'INSTALLATORE**

## ΕΓΧΕΙΡΙΔΙΟ ΟΔΗΓΙΩΝ ΕΓΚΑΤΑΣΤΑΣΗΣ

Για σωστή και ασφαλή χρήση, διαβάστε προσεκτικά αυτό το εγχειρίδιο, καθώς και το εγχειρίδιο εγκατάστασης της εξωτερικής μονάδας, πριν από την εγκατάσταση της μονάδας κλιματιστικού.

**ΓΙΑ ΑΥΤΟΝ ΠΟΥ ΚΑΝΕΙ ΤΗΝ ΕΓΚΑΤΑΣΤΑΣΗ**

## MANUAL DE INSTALAÇÃO

Para uma utilização segura e correcta, leia atentamente este manual e o manual de instalação da unidade exterior antes de instalar o aparelho de ar condicionado.

**PARA O INSTALADOR**

## INSTALLATIONSMANUAL

Læs af sikkerhedshensyn denne manual samt manualen til installation af udendørsenheden grundigt, før du installerer klimaanlægget.

**TIL INSTALLATØREN**

## INSTALLATIONSMANUAL

Läs bruksanvisningen och utomhusenhetens installationshandbok noga innan luftkonditioneringen installeras så att den används på ett säkert och korrekt sätt.

**FÖR INSTALLATÖREN**

## MONTAJ ELKİTABI

Emniyetli ve doğru kullanım için, klima cihazını monte etmeden önce bu kılavuzu ve dış ünite montaj kılavuzunu tamamiyle okuyun.

**MONTÖR İÇİN**

## РУКОВОДСТВО ПО УСТАНОВКЕ

Для обеспечения безопасной и надлежащей эксплуатации внимательно прочтите данное руководство и руководство по установке наружного прибора перед установкой кондиционера.

**ДЛЯ УСТАНОВИТЕЛЯ****English****Deutsch****Français****Nederlands****Español****Italiano****Ελληνικά****Português****Dansk****Svenska****Türkçe****Русский**

# Contents

1. Safety precautions.....	2	5. Drainage piping work.....	6
2. Installation location.....	3	6. Electrical work.....	6
3. Installing the indoor unit.....	3	7. Test run.....	11
4. Installing the refrigerant piping.....	5	8. Easy maintenance function.....	14

## 1. Safety precautions

- ▶ Before installing the unit, make sure you read all the “Safety precautions”.
- ▶ Please report to your supply authority or obtain their consent before connecting this equipment to the power supply system.

**⚠ Warning:**  
Describes precautions that must be observed to prevent danger of injury or death to the user.

**⚠ Caution:**  
Describes precautions that must be observed to prevent damage to the unit.

- ⚠ Warning:**
- Ask a dealer or an authorized technician to install the unit.
  - For installation work, follow the instructions in the Installation Manual and use tools and pipe components specifically made for use with refrigerant specified in the outdoor unit installation manual.
  - The unit must be installed according to the instructions in order to minimize the risk of damage from earthquakes, typhoons, or strong winds. An incorrectly installed unit may fall down and cause damage or injuries.
  - The unit must be securely installed on a structure that can sustain its weight.
  - If the air conditioner is installed in a small room, measures must be taken to prevent the refrigerant concentration in the room from exceeding the safety limit in the event of refrigerant leakage. Should the refrigerant leak and cause the concentration limit to be exceeded, hazards due to lack of oxygen in the room may result.

### 1.1. Before installation (Environment)

- ⚠ Caution:**
- Do not use the unit in an unusual environment. If the air conditioner is installed in areas exposed to steam, volatile oil (including machine oil), or sulfuric gas, areas exposed to high salt content such as the seaside, the performance can be significantly reduced and the internal parts can be damaged.
  - Do not install the unit where combustible gases may leak, be produced, flow, or accumulate. If combustible gas accumulates around the unit, fire or explosion may result.
  - Do not keep food, plants, caged pets, artwork, or precision instruments in the direct airflow of the indoor unit or too close to the unit, as these items can be damaged by temperature changes or dripping water.

### 1.2. Before installation or relocation

- ⚠ Caution:**
- Be extremely careful when transporting the units. Two or more persons are needed to handle the unit, as it weighs 20 kg or more. Do not grasp the packaging bands. Wear protective gloves as you can injure your hands on the fins or other parts.
  - Be sure to safely dispose of the packaging materials. Packaging materials, such as nails and other metal or wooden parts may cause stabs or other injuries.

### 1.3. Before electric work

- ⚠ Caution:**
- Be sure to install circuit breakers. If not installed, electric shock may result.
  - For the power lines, use standard cables of sufficient capacity. Otherwise, a short circuit, overheating, or fire may result.
  - When installing the power lines, do not apply tension to the cables.

### 1.4. Before starting the test run

- ⚠ Caution:**
- Turn on the main power switch more than 12 hours before starting operation. Starting operation just after turning on the power switch can severely damage the internal parts.
  - Before starting operation, check that all panels, guards and other protective parts are correctly installed. Rotating, hot, or high voltage parts can cause injuries.

After installation work has been completed, explain the “Safety Precautions,” use, and maintenance of the unit to the customer according to the information in the Operation Manual and perform the test run to ensure normal operation. Both the Installation Manual and Operation Manual must be given to the user for keeping. These manuals must be passed on to subsequent users.

⚡ :Indicates a part which must be grounded.

**⚠ Warning:**  
Carefully read the labels affixed to the main unit.

- Ventilate the room if refrigerant leaks during operation. If refrigerant comes into contact with a flame, poisonous gases will be released.
- All electric work must be performed by a qualified technician according to local regulations and the instructions given in this manual.
- Use only specified cables for wiring.
- The terminal block cover panel of the unit must be firmly attached.
- Use only accessories authorized by Mitsubishi Electric and ask a dealer or an authorized technician to install them.
- The user should never attempt to repair the unit or transfer it to another location.
- After installation has been completed, check for refrigerant leaks. If refrigerant leaks into the room and comes into contact with the flame of a heater or portable cooking range, poisonous gases will be released.

- When the room humidity exceeds 80% or when the drainpipe is clogged, water may drip from the indoor unit. Do not install the indoor unit where such dripping can cause damage.
- When installing the unit in a hospital or communications office, be prepared for noise and electronic interference. Inverters, home appliances, high-frequency medical equipment, and radio communications equipment can cause the air conditioner to malfunction or breakdown. The air conditioner may also affect medical equipment, disturbing medical care, and communications equipment, harming the screen display quality.

- Thermal insulation of the refrigerant pipe is necessary to prevent condensation. If the refrigerant pipe is not properly insulated, condensation will be formed.
- Place thermal insulation on the pipes to prevent condensation. If the drainpipe is installed incorrectly, water leakage and damage to the ceiling, floor, furniture, or other possessions may result.
- Do not clean the air conditioner unit with water. Electric shock may result.
- Tighten all flare nuts to specification using a torque wrench. If tightened too much, the flare nut can break after an extended period.

- Be sure to ground the unit. If the unit is not properly grounded, electric shock may result.
- Use circuit breakers (ground fault interrupter, isolating switch (+B fuse), and molded case circuit breaker) with the specified capacity. If the circuit breaker capacity is larger than the specified capacity, breakdown or fire may result.

- Do not operate the air conditioner without the air filter set in place. If the air filter is not installed, dust may accumulate and breakdown may result.
- Do not touch any switch with wet hands. Electric shock may result.
- Do not touch the refrigerant pipes with bare hands during operation.
- After stopping operation, be sure to wait at least five minutes before turning off the main power switch. Otherwise, water leakage or breakdown may result.

## 2. Installation location

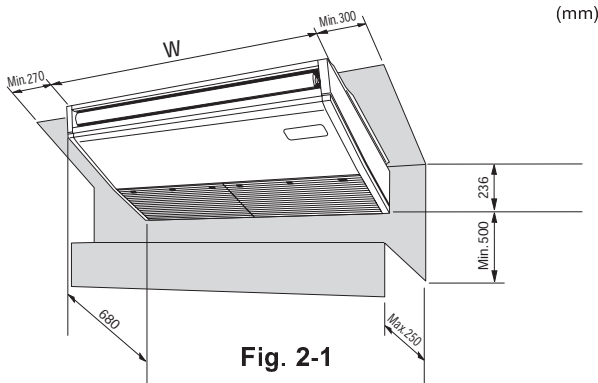

Fig. 2-1

### 2.1. Outline dimensions (Indoor unit) (Fig. 2-1)

Select a proper position allowing the following clearances for installation and maintenance.

Models	W
RP50	960
RP60,71	1280
RP100,125,140	1600

⚠ Warning:

Mount the indoor unit on a ceiling strong enough to withstand the weight of the unit.

### 2.2. Outline dimensions (Outdoor unit)

Refer to the outdoor unit installation manual.

## 3. Installing the indoor unit

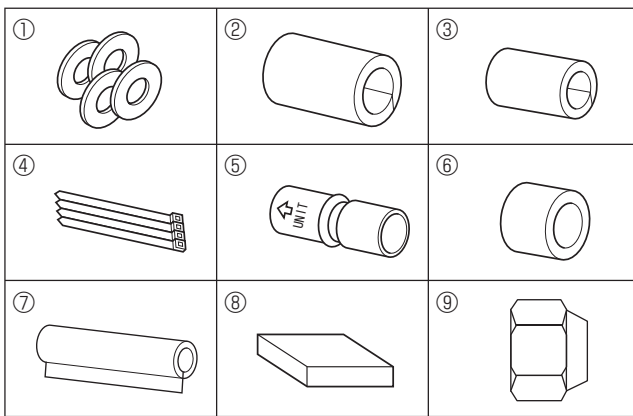

Fig. 3-1

### 3.1. Check the indoor unit accessories (Fig. 3-1)

The indoor unit should be supplied with the following accessories (contained in the inside of the intake grille).

	Accessory name	Q'ty
①	Washer	4 pcs
②	Pipe cover	1 pc Large size (For gas tubing)
③	Pipe cover	1 pc Small size (For liquid tubing)
④	Band	4 pcs
⑤	Joint socket	1 pc Marked with "UNIT"
⑥	Socket cover	1 pc
⑦	Drain tubing cover	1 pc
⑧	Wired remote controller	1 pc
⑨	Flare nut	1 pc ø6.35 (RP60 only)

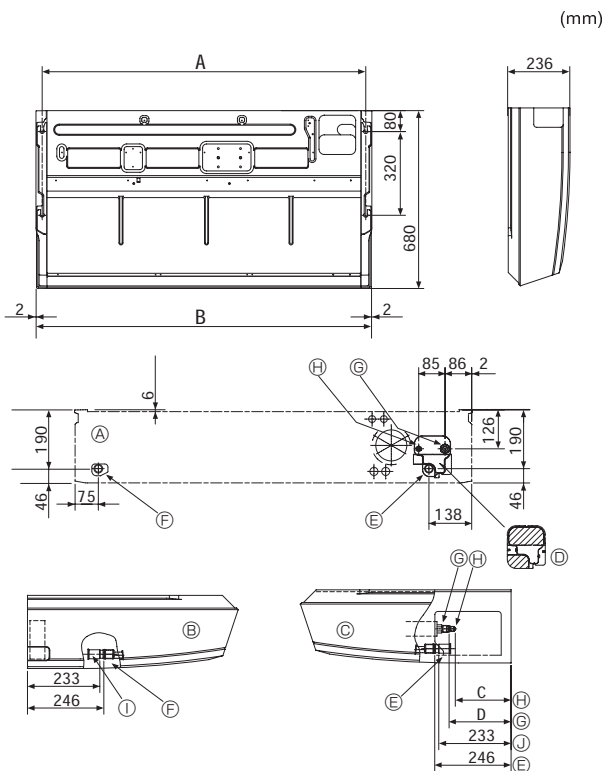

Fig. 3-2

### 3.2. Preparation for installation (Fig. 3-2)

#### 3.2.1. Suspension bolt installing spacing

Models	A	B
RP50	917	960
RP60,71	1237	1280
RP100,125,140	1557	1600

#### 3.2.2. Refrigerant and drain tubing location

Models	C	D
RP50	184	203
RP60	179	203
RP71-140	180	200

- Ⓐ Front side outlet
- Ⓑ Left side outlet
- Ⓒ Right side outlet
- Ⓓ Independent piece (Removable)
- Ⓔ Right drain tubing
- Ⓕ Left drain tubing
- Ⓖ Gas tubing
- Ⓗ Liquid tubing
- Ⓙ Rubber plug
- Ⓚ with Joint socket Ⓔ

In case of the rear pipe arrangement, make sure to remove the shaded portions from the Ⓓ independent piece. Then put the Ⓚ independent piece back in initial position.

(The heat exchanger might be clogged because of dust)

### 3. Installing the indoor unit

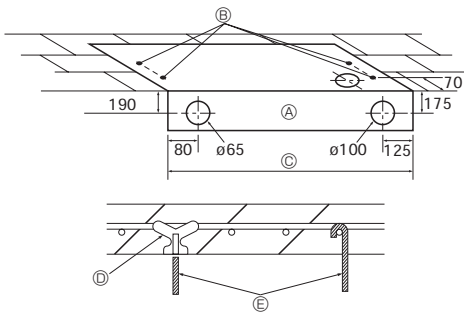

Fig. 3-3

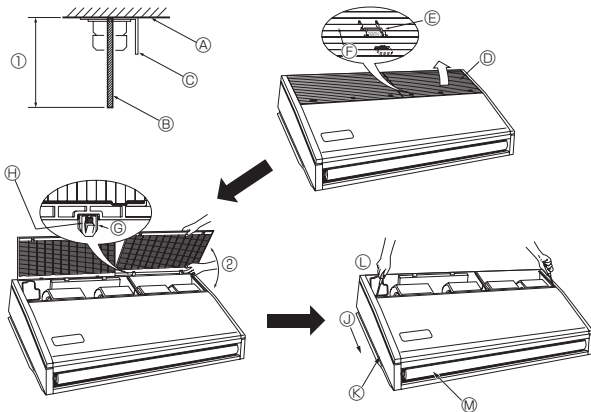

Fig. 3-4

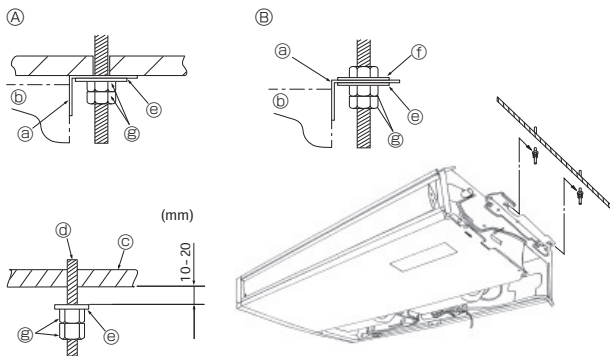

Fig. 3-5

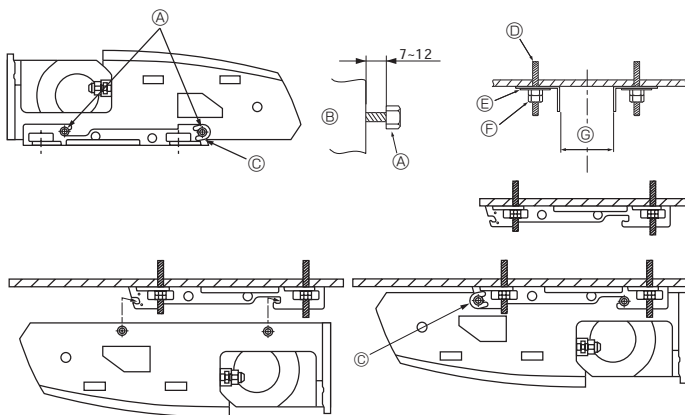

Fig. 3-6

#### 3.2.3. Selection of suspension bolts and tubing positions (Fig. 3-3)

Using the pattern paper provided for installation, select proper positions for suspension bolts and tubing and prepare relative holes.

- Ⓐ Pattern paper
- Ⓑ Suspension bolt hole
- Ⓒ Indoor unit width

Secure the suspension bolts or use angle stock braces or square timbers for bolt installation.

- Ⓓ Use inserts of 100 kg to 150 kg each.
- Ⓔ Use suspension bolts of W3/8 or M10 in size.

#### 3.2.4. Indoor unit preparation (Fig. 3-4)

1. Install the suspending bolts. (Procure the W3/8 or M10 bolts locally.)

Predetermine the length from the ceiling (Ⓓ) within 100 mm.

Ⓐ Ceiling surface Ⓑ Suspending bolt Ⓒ Suspending bracket

2. Remove the intake grille.

Slide the intake grille holding knobs (at 2 or 3 locations) backward to open the intake grille.

3. Remove the side panel.

Remove the side panel holding screws (one in each side, right and left) then slide the side panel forward for removal.

- Ⓓ Intake grille
- Ⓔ Slide the side panel forward.
- Ⓕ Intake grille holding knob
- Ⓚ Side panel
- Ⓖ Slide
- Ⓛ Remove the side panel holding screws.
- Ⓖ Hinge
- Ⓜ Remove the protective vinyl of vane.
- Ⓗ Pushing the hinge, pull out the intake grille.
- Ⓗ Forcing open the intake grille or opening it to an angle of more than 120° may damage the hinges.

### 3.3. Installing the indoor unit (Fig. 3-5)

Use a proper suspending method depending on the presence or absence of ceiling materials as follows.

- Ⓐ In the presence of ceiling materials
- Ⓒ Ceiling
- Ⓑ In the absence of ceiling materials
- Ⓓ Suspending bolt
- Ⓓ Suspending bracket
- Ⓔ Washer ①
- Ⓓ Unit
- Ⓕ Washer (Local procurement)
- Ⓓ Double nuts

#### 1) Directly suspending the unit

Installing procedures

1. Install the washer ① (supplied with the unit) and the nuts (to be locally procured).
2. Set (hook) the unit through the suspending bolts.
3. Tighten the nuts.

Check the unit installing condition.

- Check that the unit is horizontal between the right and left sides.
- Check that the front and the rear of suspending brackets are horizontal.  
(To keep drainage, the unit is inclined to the suspending brackets. The unit slopes continuously downward from the front to the rear is the right installation position.)

#### 2) Installing the suspending bracket first onto the ceiling (Fig. 3-6)

Installing procedures

1. Remove the suspending brackets and U-shaped washers from the unit.
2. Adjust the suspending bracket holding bolts on the unit.
3. Attach the suspending brackets to the suspending bolts.
4. Check that the suspending brackets are horizontal (front and rear/right and left).
5. Set (hook) the unit to the suspending brackets.
6. Tighten fixed bolts of the suspending brackets.

\* Be sure to install the U-shaped washers.

- Ⓐ Suspending bracket holding bolt
- Ⓑ Unit
- Ⓒ U-shaped washer
- Ⓓ Suspending bolt
- Ⓔ Washer ①
- Ⓓ Double nuts

	(mm)	
Ⓒ	RP50	882-887
	RP60,71	1202-1207
	RP100-140	1522-1527

## 4. Installing the refrigerant piping

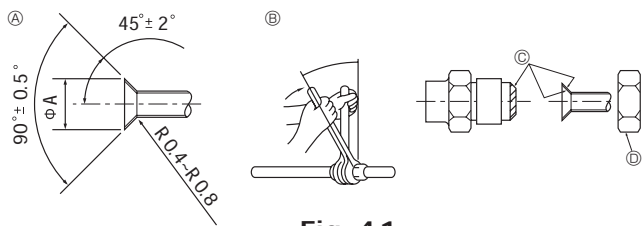

Fig. 4-1

Ⓐ Flare cutting dimensions

Copper pipe O.D. (mm)	Flare dimensions φA dimensions (mm)
φ6.35	8.7 - 9.1
φ9.52	12.8 - 13.2
φ12.7	16.2 - 16.6
φ15.88	19.3 - 19.7
φ19.05	23.6 - 24.0

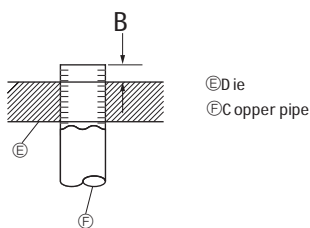

Fig. 4-2

Copper pipe O.D. (mm)	B (mm)
	F flare tool for R 410A Clutch type
φ6.35 (1/4")	0 - 0.5
φ9.52 (3/8")	0 - 0.5
φ12.7 (1/2")	0 - 0.5
φ15.88 (5/8")	0 - 0.5
φ19.05 (3/4")	0 - 0.5

### 4.1. Precautions

For devices that use R410A refrigerant

- Use ester oil, ether oil or alkylbenzene oil (small amount) as the refrigeration oil applied to the flared sections.
- Use C1220 copper phosphorus for copper and copper alloy seamless pipes, to connect the refrigerant pipes. Use refrigerant pipes with the thicknesses specified in the table below. Make sure the insides of the pipes are clean and do not contain any harmful contaminants such as sulfuric compounds, oxidants, debris, or dust.

#### ⚠ Warning:

When installing or moving the air conditioner, use only the specified refrigerant (R410A) to charge the refrigerant lines. Do not mix it with any other refrigerant and do not allow air to remain in the lines. Air enclosed in the lines can cause pressure peaks resulting in a rupture and other hazards.

	RP35, 50	RP60-140
Liquid pipe	φ 6.35 thickness 0.8 mm	φ 9.52 thickness 0.8 mm
Gas pipe	φ 12.7 thickness 0.8 mm	φ 15.88 thickness 1.0 mm

- Do not use pipes thinner than those specified above.

### 4.2. Connecting pipes (Fig. 4-1)

- When commercially available copper pipes are used, wrap liquid and gas pipes with commercially available insulation materials (heat-resistant to 100 °C or more, thickness of 12 mm or more).
- The indoor parts of the drain pipe should be wrapped with polyethylene foam insulation materials (specific gravity of 0.03, thickness of 9 mm or more).
- Apply thin layer of refrigerant oil to pipe and joint seating surface before tightening flare nut.
- Use 2 wrenches to tighten piping connections.
- Use refrigerant piping insulation provided to insulate indoor unit connections. Insulate carefully.

Ⓑ Flare nut tightening torque

Copper pipe O.D. (mm)	Flare nut O.D. (mm)	Tightening torque (N·m)
φ6.35	17	14-18
φ6.35	22	34-42
φ9.52	22	34-42
φ12.7	26	49-61
φ12.7	29	68-82
φ15.88	29	68-82
φ15.88	36	100-120
φ19.05	36	100-120

Ⓒ Apply refrigerating machine oil over the entire flare seat surface.

Ⓓ Use correct flare nuts meeting the pipe size of the outdoor unit.

#### Available pipe size

	RP35, 50	RP60	RP71-140
Liquid side	φ6.35 O	φ6.35	—
Gas side	φ12.7 O	φ15.88 O	φ15.88 O

O : Factory flare nut attachment to the heat exchanger.

### 4.3. Indoor unit (Fig. 4-3)

#### Installing procedures

1. Slide the supplied pipe cover ② over the gas tubing until it is pressed against the sheet metal inside the unit.
2. Slide the provided pipe cover ③ over the liquid tubing until it is pressed against the sheet metal inside the unit.
3. Tighten the pipe covers ② and ③ at the both ends (20 mm) with the supplied bands ④.

- Ⓐ Gas tubing
- Ⓑ Pipe cover ②
- Ⓒ Liquid tubing
- Ⓓ Press the pipe cover against the sheet metal.
- Ⓔ Band ④
- Ⓕ Refrigerant tubing heat insulating material
- Ⓖ Pipe cover ③

### 4.4. For twin/triple combination

Refer to the outdoor unit installation manual.

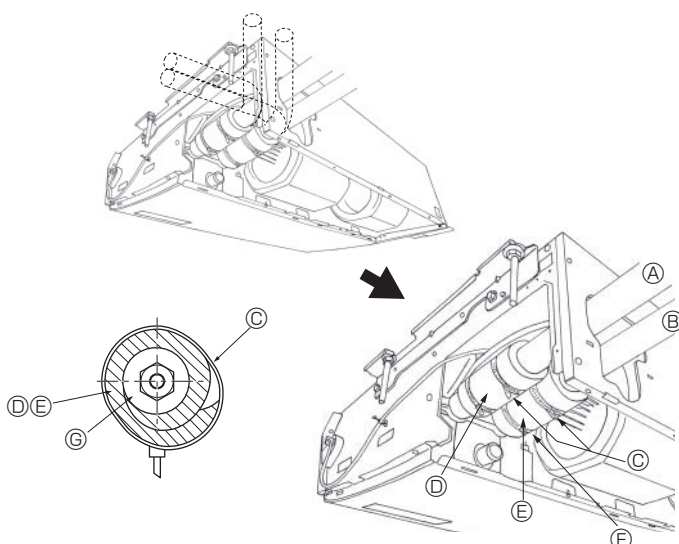

Fig. 4-3

## 5. Drainage piping work

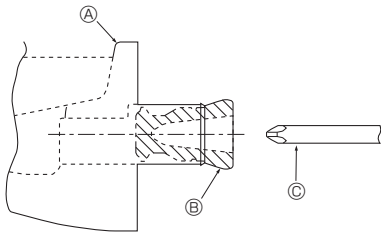

Fig. 5-1

- For left side tubing, be sure to insert the rubber plug into the right drain port. (Fig. 5-1)
- Use VP-20 (O.D. ø26 (1") PVC TUBE) for drain piping and provide 1/100 or more downward slope.
- After completion of work, check that correct drain is available from the outflow port of the drain tubing.

- Ⓐ Drain pan
- Ⓑ Plug
- Ⓒ Insert the driver etc.in the plug deeply.

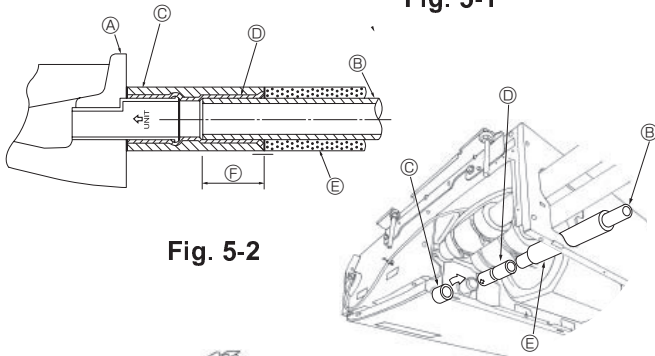

Fig. 5-2

### Installing procedures (Fig. 5-2)

1. Attach the joint socket ⑤ supplied with the unit to the drain port on the unit with a vinyl chloride adhesive.
2. Fasten the socket cover ⑥ supplied with the unit to the joint socket ⑤.
3. Attach the field drain tubing (VP-20) to the joint socket ⑤ with a vinyl chloride adhesive.
4. Wrap the drain tubing cover ⑦ supplied with the unit. (Seam taping)

- Ⓐ Drain pan
- Ⓑ Drain tubing
- Ⓒ Socket cover ⑥
- Ⓓ Joint socket ⑤
- Ⓔ Drain tubing cover ⑦
- Ⓕ Insertion length 37mm

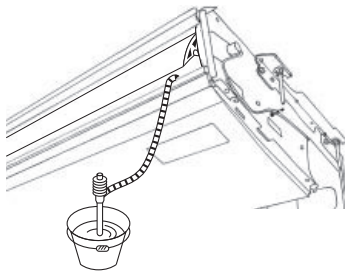

Fig. 5-3

### 5. Check for correct drainage. (Fig. 5-3)

- \* Fill the drain pan with water of about 1 L from the air outlet.

## 6. Electrical work

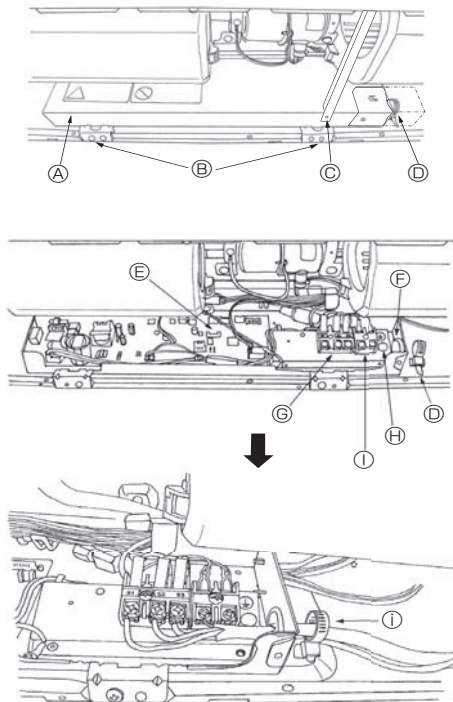

Fig. 6-1

### 6.1. Electric wiring (Fig. 6-1)

#### Wiring procedures

1. Remove the tapping screw ③ then remove the beam.
2. Remove the (2) tapping screws ② then remove the electric part cover ①.
3. Connect the electric wires securely to the corresponding terminals.
4. Replace the removed parts.
5. Tie the electric wires with the local wiring clamp located in the right side of the junction box.

- Ⓐ Cover
- Ⓑ Set screws (2 pcs)
- Ⓒ Set screws (Beam)
- Ⓓ Wiring clamp
- Ⓔ Control board
- Ⓕ Wire service entrance
- Ⓖ Terminal block for indoor and outdoor units connection
- Ⓗ Grounding cable connector
- Ⓘ Terminal block for Remote controller
- Ⓣ Secure with the wiring clamp.

## 6. Electrical work

### 6.1.1. Indoor unit power supplied from outdoor unit

The following connection patterns are available.

The outdoor unit power supply patterns vary on models.

#### 1:1 System

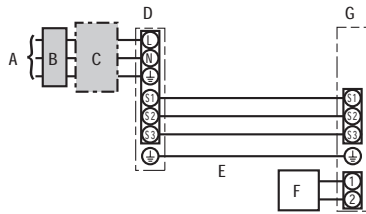

- A Outdoor unit power supply
- B Earth leakage breaker
- C Wiring circuit breaker or isolating switch
- D Outdoor unit
- E Indoor unit/outdoor unit connecting cables
- F Remote controller
- G Indoor unit

\* Affix label A that is included with the manuals near each wiring diagram for the indoor and outdoor units.

#### Simultaneous twin/triple/quadruple system

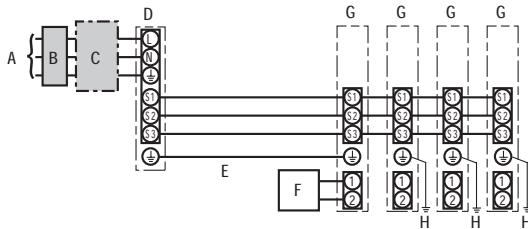

- A Outdoor unit power supply
- B Earth leakage breaker
- C Wiring circuit breaker or isolating switch
- D Outdoor unit
- E Indoor unit/outdoor unit connecting cables
- F Remote controller
- G Indoor unit
- H Indoor unit earth

\* Affix label A that is included with the manuals near each wiring diagram for the indoor and outdoor units.

Indoor unit model		PCA	
Wiring Wire No. x size (mm <sup>2</sup> )	Indoor unit-Outdoor unit	*1	3× 1.5 (polar)
	Indoor unit-Outdoor unit earth	*1	1 × Min.1.5
	Indoor unit earth		1 × Min.1.5
	Remote controller-Indoor unit	*2	2 × 0.3 (Non-polar)
Circuit rating	Indoor unit (Heater) L-N	*3	-
	Indoor unit-Outdoor unit S1-S2	*3	AC 230 V
	Indoor unit-Outdoor unit S2-S3	*3	DC24 V
	Remote controller-Indoor unit	*3	DC12 V

\*1. <For 50-140 outdoor unit application>

Max. 45 m

If 2.5 mm<sup>2</sup> used, Max. 50 m

If 2.5 mm<sup>2</sup> used and S3 separated, Max. 80 m

<For 200/250 outdoor unit application>

Max. 18 m

If 2.5 mm<sup>2</sup> used, Max. 30 m

If 4 mm<sup>2</sup> used and S3 separated, Max. 50 m

If 6 mm<sup>2</sup> used and S3 separated, Max. 80 m

\*2. The 10 m wire is attached in the remote controller accessory. Max. 500 m

\*3. The figures are NOT always against the ground.

S3 terminal has DC 24 V against S2 terminal. However between S3 and S1, these terminals are not electrically insulated by the transformer or other device.

Notes: 1. Wiring size must comply with the applicable local and national code.

2. Power supply cords and indoor unit/outdoor unit connecting cords shall not be lighter than polychloroprene sheathed flexible cord. (Design 60245 IEC 57)

3. Install an earth longer than other cables.

### 6.1.2. Separate indoor unit/outdoor unit power supplies (For PUHZ application only)

The following connection patterns are available.

The outdoor unit power supply patterns vary on models.

#### 1:1 System

\* The indoor power supply terminal kit is required.

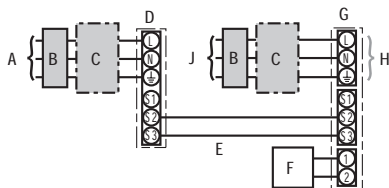

- A Outdoor unit power supply
- B Earth leakage breaker
- C Wiring circuit breaker or isolating switch
- D Outdoor unit
- E Indoor unit/outdoor unit connecting cables
- F Remote controller
- G Indoor unit
- H Option
- J Indoor unit power supply

\* Affix label B that is included with the manuals near each wiring diagram for the indoor and outdoor units.

## 6. Electrical work

### Simultaneous twin/triple/quadruple system

\* The indoor power supply terminal kits are required.

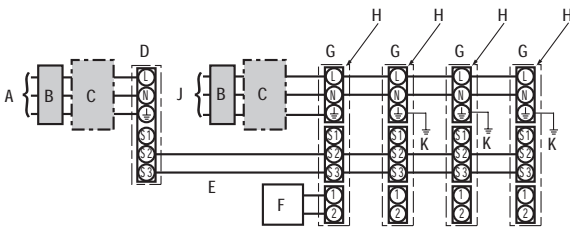

- A Outdoor unit power supply
- B Earth leakage breaker
- C Wiring circuit breaker or isolating switch
- D Outdoor unit
- E Indoor unit/outdoor unit connecting cables
- F Remote controller
- G Indoor unit
- H Option
- J Indoor unit power supply
- K Indoor unit earth

\* Affix label B that is included with the manuals near each wiring diagram for the indoor and outdoor units.

If the indoor and outdoor units have separate power supplies, refer to the table below. If the indoor power supply terminal kit is used, change the indoor unit electrical box wiring referring to the figure in the right and the DIP switch settings of the outdoor unit control board.

	Indoor unit specifications								
Indoor power supply terminal kit (option)	Required								
Indoor unit electrical box connector connection change	Required								
Label affixed near each wiring diagram for the indoor and outdoor units	Required								
Outdoor unit DIP switch settings (when using separate indoor unit/outdoor unit power supplies only)	<table border="1"> <tr> <td>ON</td> <td></td> <td></td> <td>3</td> </tr> <tr> <td>OFF</td> <td>1</td> <td>2</td> <td>(SW 8)</td> </tr> </table> <p>Set the SW8-3 to ON.</p>	ON			3	OFF	1	2	(SW 8)
ON			3						
OFF	1	2	(SW 8)						

\* There are 3 types of labels (labels A, B and C). Affix the appropriate labels to the units according to the wiring method.

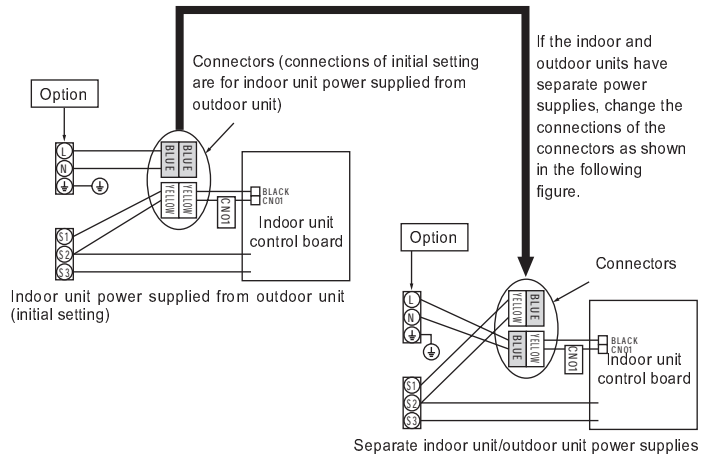

Indoor unit model		PCA
Indoor unit power supply		~N (single), 50 Hz, 230 V
Indoor unit input capacity		16 A
Main switch (Breaker)	*1	
Wiring x Wire No. x Wire size (mm <sup>2</sup> )	Indoor unit power supply & earth	3 x Min. 1.5
	Indoor unit-Outdoor unit	*2 2 x Min. 0.3
	Indoor unit-Outdoor unit earth	-
	Remote controller-Indoor unit	*3 2 x 0.3 (Non-polar)
Circuit rating	Indoor unit L-N	*4 AC 230 V
	Indoor unit-Outdoor unit S1-S2	*4 -
	Indoor unit-Outdoor unit S2-S3	*4 DC24 V
	Remote controller-Indoor unit	*4 DC12 V

\*1. A breaker with at least 3.0 mm contact separation in each pole shall be provided. Use earth leakage breaker (NV). The breaker shall be provided to ensure disconnection of all active phase conductors of the supply.

\*2. Max. 120 m

\*3. The 10 m wire is attached in the remote controller accessory. Max. 500 m

\*4. The figures are NOT always against the ground.

Notes: 1. Wiring size must comply with the applicable local and national code.

2. Power supply cords and indoor unit/outdoor unit connecting cords shall not be lighter than polychloroprene sheathed flexible cord. (Design 60245 IEC 57)

3. Install an earth longer than other cables.

## 6.2. Remote controller

### 6.2.1. For wired remote controller

#### 1) Installing procedures

(1) Select an installing position for the remote controller. (Fig. 6-2)

The temperature sensors are located on both remote controller and indoor unit.

#### ► Procure the following parts locally:

- 2 piece switch box
- Thin copper conduit tube
- Lock nuts and bushings

#### [Fig.6-2]

- Ⓐ Remote controller profile
- Ⓑ Required clearances surrounding the remote controller
- Ⓒ Installation pitch

(2) Seal the service entrance for the remote controller cord with putty to prevent possible invasion of dew drops, water, cockroaches or worms. (Fig. 6-3)

Ⓐ For installation in the switch box

Ⓑ For direct installation on the wall, select one of the following:

- Prepare a hole through the wall to pass the remote controller cord (in order to run the remote controller cord from the back), then seal the hole with putty.
- Run the remote controller cord through the cut-out upper case, then seal the cut-out notch with putty.

**B-1. To lead the remote controller cord from the back of the controller**  
**B-2. To run the remote controller cord through the upper portion**

#### [Fig.6-3]

- Ⓒ Wall
- Ⓓ Lock nut
- Ⓔ Switch box
- Ⓜ Seal with putty
- Ⓕ Conduit
- Ⓗ Bushing
- Ⓝ Remote controller cord
- Ⓟ Wood screw

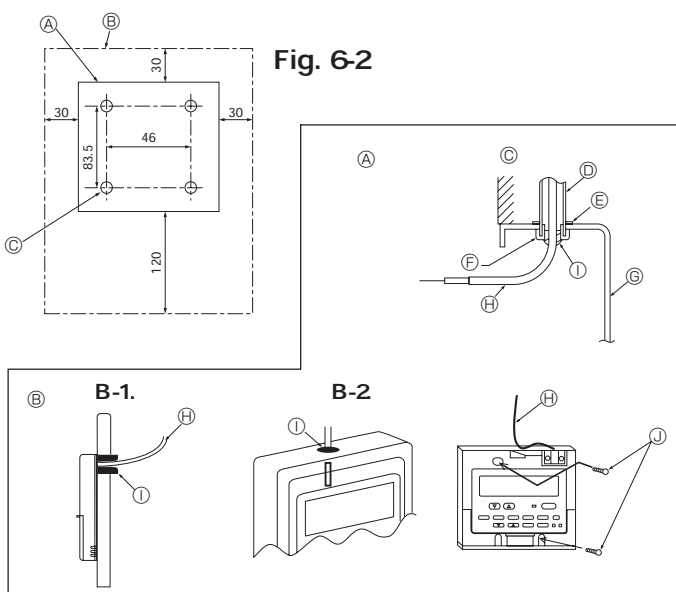

Fig. 6-2

Fig. 6-3



## 6. Electrical work

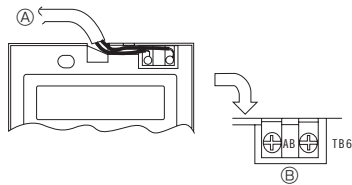

Fig. 6-4

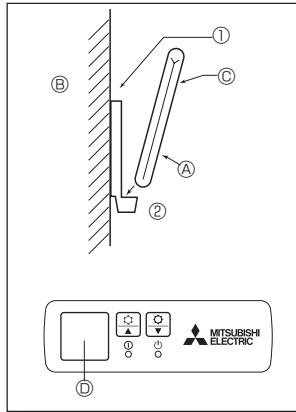

Fig. 6-5

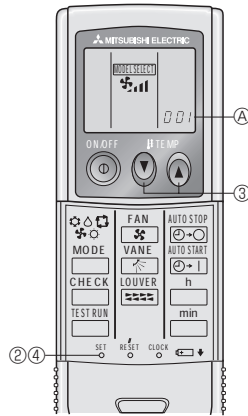

Fig. 6-6

### 2) Connecting procedures (Fig. 6-4)

- ① Connect the remote controller cord to the terminal block.
  - Ⓐ To TB5 on the indoor unit
  - Ⓑ TB6 (No polarity)

### 3) 2 remote controllers setting

If 2 remote controllers are connected, set one to "Main" and the other to "Sub". For setting procedures, refer to "Function selection of remote controller" in the operation manual for the indoor unit.

### 6.2.2. For wireless remote controller

#### 1) Installation area

- Area in which the remote controller is not exposed to direct sunshine.
- Area in which there is no nearby heating source.
- Area in which the remote controller is not exposed to cold (or hot) winds.
- Area in which the remote controller can be operated easily.
- Area in which the remote controller is beyond the reach of children.

#### 2) Installation method (Fig. 6-5)

- ① Attach the remote controller holder to the desired location using 2 tapping screws.
- ② Place the lower end of the controller into the holder.

- Ⓐ Remote controller Ⓑ Wall Ⓒ Display panel Ⓓ Receiver
- The signal can travel up to approximately 7 meters (in a straight line) within 45 degrees to both right and left of the center line of the receiver.

#### 3) Setting (Fig. 6-6)

- ① Insert batteries.
- ② Press the SET button with something sharp at the end. **MODEL SELECT** blinks and Model No. is lighted.
- ③ Press the temp  $\uparrow$   $\downarrow$  buttons to set the Model No. If you mistook the operation, press the ON/OFF  $\text{\textcircled{P}}$  button and operate again from procedure ③.
- ④ Press the SET button with something sharp at the end. **MODEL SELECT** and Model No. are lighted for 3 seconds, then turned off.

Indoor	Outdoor	Ⓐ Model No.
PCA	PUH, PUHZ, SUZ	001
	PU	033

#### 4) Assigning a remote controller to each unit (Fig. 6-7)

Each unit can be operated only by the assigned remote controller. Make sure each pair of an indoor unit PC board and a remote controller is assigned to the same pair No.

#### 5) Wireless remote controller pair number setting operation

- ① Press the SET button with something sharp at the end. Start this operation from the status of remote controller display turned off. **MODEL SELECT** blinks and Model No. is lighted.
- ② Press the  $\text{min}$  button twice continuously. Pair No. "0" blinks.
- ③ Press the temp  $\uparrow$   $\downarrow$  buttons to set the pair number you want to set. If you mistook the operation, press the ON/OFF  $\text{\textcircled{P}}$  button and operate again from procedure ②.
- ④ Press the SET button with something sharp at the end. Set pair number is lighted for 3 seconds then turned off.

Ⓐ Pair No. of wireless remote controller	Indoor PC board
0	Initial setting
1	Cut J41
2	Cut J42
3-9	Cut J41, J42

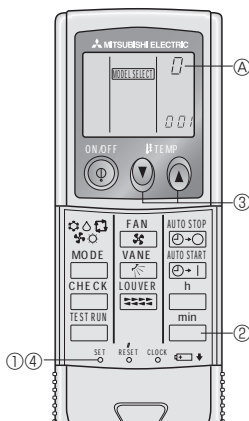

Fig. 6-7

## 6. Electrical work

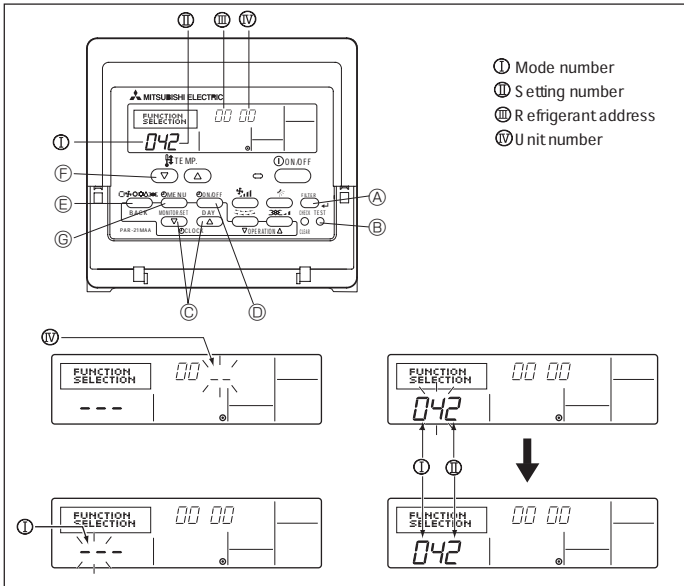

Fig. 6-8

### 6.3. Function settings

#### 6.3.1. Function setting on the unit (Selecting the unit functions)

##### 1) For wired remote controller (Fig. 6-8)

Changing the power voltage setting

- Be sure to change the power voltage setting depending on the voltage used.

- Go to the function setting mode.  
Switch OFF the remote controller.  
Press the FILTER (A) and TEST RUN (B) buttons simultaneously and hold them for at least 2 seconds. FUNCTION will start to blink.
- Use the (C) buttons to set the refrigerant address (III) to 00.
- Press (D) button and [-] will start to blink in the unit number (IV) display.
- Use the (C) buttons to set the unit number (IV) to 00.
- Press the MODE button (E) to designate the refrigerant address/unit number. [-] will blink in the mode number (I) display momentarily.
- Press the (F) buttons to set the mode number (I) to 04.
- Press the (G) button and the current set setting number (II) will blink.  
Use the (F) button to switch the setting number in response to the power supply voltage to be used.

Power supply voltage

240 V : setting number = 1

220 V, 230 V : setting number = 2

- Press the MODE button (E) and mode and the setting number (I) and (II) will change to being on constantly and the contents of the setting can be confirmed.
- Press the FILTER (A) and TEST RUN (B) buttons simultaneously for at least 2 seconds. The function selection screen will disappear momentarily and the air conditioner OFF display will appear.

##### 2) For wireless remote controller (Fig. 6-9)

Changing the power voltage setting

- Be sure to change the power voltage setting depending on the voltage used.

- Going to the function select mode

Press the CHECK (F) button twice continuously.

(Start this operation from the status of remote controller display turned off.)

CHECK is lighted and "00" blinks.

Press the (G) temp button (G) once to set "50". Direct the wireless remote controller toward the receiver of the indoor unit and press the (A) button (A).

- Setting the unit number

Press the (G) (H) temp buttons (G) and (H) to set the unit number "00". Direct the wireless remote controller toward the receiver of the indoor unit and press the (A) button (A).

- Selecting a mode

Enter 04 to change the power voltage setting using the (G) (H) temp buttons (G) and (H). Direct the wireless remote controller toward the receiver of the indoor unit and press the (A) button (A).

Current setting number: 1 = 1 beep (1 second)

2 = 2 beeps (1 second each)

3 = 3 beeps (1 second each)

- Selecting the setting number

Use the (G) (H) temp buttons (G) and (H) to change the power voltage setting to 01 (240 V). Direct the wireless remote controller toward the sensor of the indoor unit and press the (A) button (A).

- To select multiple functions continuously

Repeat steps ③ and ④ to change multiple function settings continuously.

- Complete function selection

Direct the wireless remote controller toward the sensor of the indoor unit and press the (E) button (E).

**Note: Whenever changes are made to the function settings after installation or maintenance, be sure to record the changes with a mark in the "Setting" column of the Function table.**

#### 6.3.2. Function setting on the remote controller

Refer to the indoor unit operation manual.

#### Function table

Select unit number 00

Mode	Settings	Mode no.	Setting no.	Initial setting	setting
Power failure automatic recovery	Not available	01	1		
	Available *		2	O	
Indoor temperature detecting	Indoor unit operating average	02	1	O	
	Set by indoor unit's remote controller		2		
	Remote controller's internal sensor		3		
LOSSNAY connectivity	Not Supported	03	1	O	
	Supported (indoor unit is not equipped with outdoor-air intake)		2		
	Supported (indoor unit is equipped with outdoor-air intake)		3		
Power voltage	240 V	04	1		
	220 V, 230 V		2	O	

## 6. Electrical work

Select unit numbers 01 to 03 or all units (AL [wired remote controller]/07 [wireless remote controller])

Mode	Settings	Mode no.	Setting no.	Initial setting	setting
Filter sign	100Hr	07	1		
	2500Hr		2	O	
	No filter sign indicator		3		
Fan speed	Silent	08	1		
	Standard		2	O	
	High ceiling		3		
Up/down vane setting	No vanes	11	1		
	Equipped with vanes (vanes angle setup ①)		2	O	
	Equipped with vanes (vanes angle setup ②)		3		

※ When the power supply returns, the air conditioner will start 3 minutes later.

## 7. Test run

### 7.1. Before test run

- ▶ After completing installation and the wiring and piping of the indoor and outdoor units, check for refrigerant leakage, looseness in the power supply or control wiring, wrong polarity, and no disconnection of one phase in the supply.
- ▶ Use a 500-volt megohmmeter to check that the resistance between the power supply terminals and ground is at least 1.0 MΩ.

- ▶ Do not carry out this test on the control wiring (low voltage circuit) terminals.

⚠ Warning:

Do not use the air conditioner if the insulation resistance is less than 1.0 MΩ.

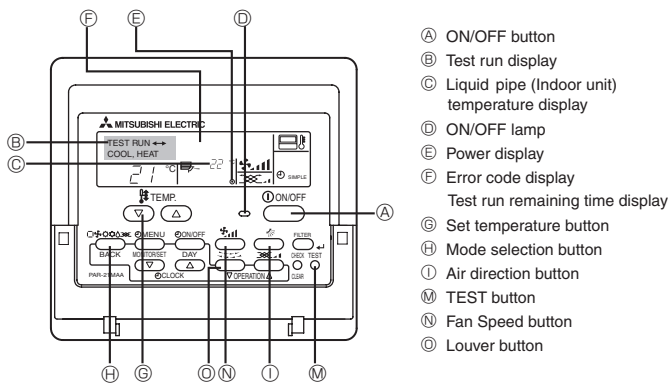

Fig. 7-1

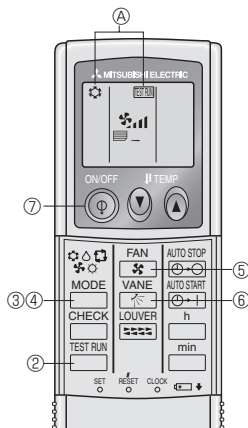

Fig. 7-2

### 7.2. Test run

The following 3 methods are available.

#### 7.2.1. Using wired remote controller (Fig. 7-1)

- ① Turn on the power at least 12 hours before the test run.
- ② Press the [TEST] button twice. ➡ "TEST RUN" liquid crystal display
- ③ Press the [Mode selection] button and switch to the cooling (or heating) mode. ➡ Make sure that cold (or warm) wind is blown out.
- ④ Press the [Fan speed] button. ➡ Make sure that the wind speed is switched.
- ⑤ Press the [Air direction button] or [Louver button]. ➡ Check operation of the vane or louver.
- ⑥ Check operation of the outdoor unit fan.
- ⑦ Release test run by pressing the [ON/OFF] button. ➡ Stop
- ⑧ Register a telephone number.

The telephone number of the repair shop, sales office, etc., to contact if an error occurs can be registered in the remote controller. The telephone number will be displayed when an error occurs. For registration procedures, refer to the operation manual for the indoor unit.

#### 7.2.2. Using wireless remote controller (Fig. 7-2)

- ① Turn on the power to the unit at least 12 hours before the test run.
- ② Press the button twice continuously. (Start this operation from the status of remote controller display turned off.)  
A and current operation mode are displayed.
- ③ Press the button to activate COOL mode, then check whether cool air is blown out from the unit.
- ④ Press the button to activate HEAT mode, then check whether warm air is blown out from the unit.
- ⑤ Press the button and check whether fan speed changes.
- ⑥ Press the button and check whether the auto vane operates properly.
- ⑦ Press the ON/OFF button to stop the test run.

Note:

- Point the remote controller towards the indoor unit receiver while following steps ② to ⑦.
- It is not possible to run the TEST RUN in FAN, DRY or AUTO mode.

#### 7.2.3. Using SW4 in outdoor unit

Refer to the outdoor unit installation manual.

## 7. Test run

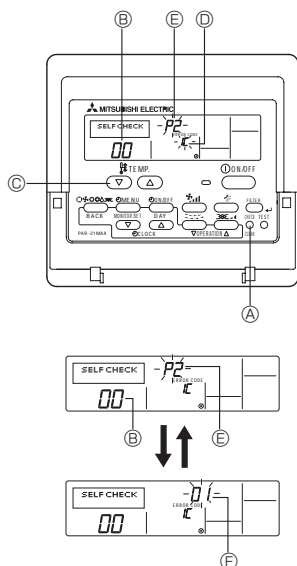

Fig. 7-3

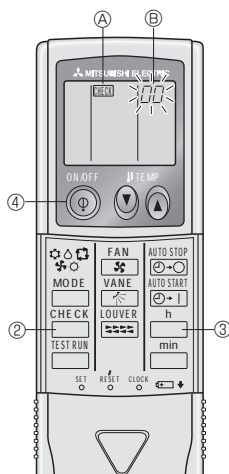

Fig. 7-4

### 7.3. Self-check

#### 7.3.1. Wired remote controller (Fig. 7-3)

- ① Turn on the power.
- ② Press the [CHECK] button.
- ③ Set refrigerant address with [TEMP] button if system control is used.
- ④ Press the [ON/OFF] button to stop the self-check.

- Ⓐ CHECK button
- Ⓑ Refrigerant address
- Ⓒ TEMP. button
- Ⓓ IC: Indoor unit  
OC: Outdoor unit
- Ⓔ Check code
- Ⓕ Unit address

#### 7.3.2. Wireless remote controller (Fig. 7-4)

- ① Turn on the power.
- ② Press the  button twice.  
(Start this operation from the status of remote controller display turned off.)

- Ⓐ [CHECK] begins to light.
- Ⓑ "00" begins to blink.

- ③ While pointing the remote controller toward the unit's receiver, press the  button. The check code will be indicated by the number of times that the buzzer sounds from the receiver section and the number of blinks of the operation lamp.
- ④ Press the ON/OFF button to stop the self-check.

• Refer to the following tables for details on the check codes. (Wireless remote controller)

[Output pattern A]

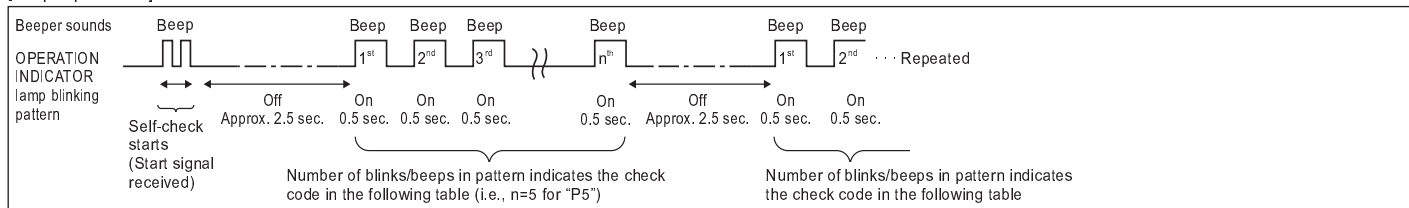

[Output pattern B]

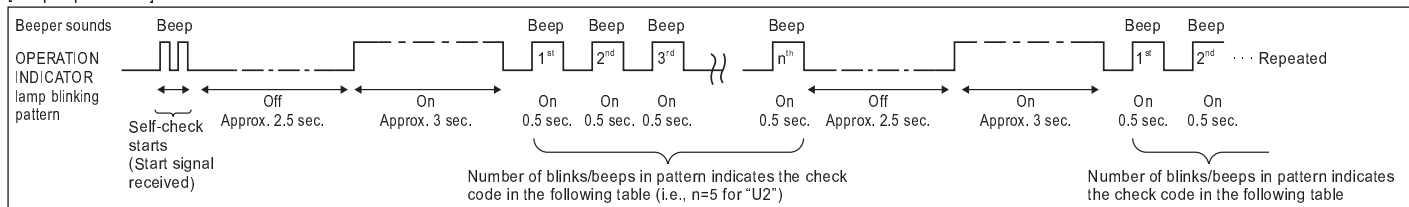

[Output pattern A] Errors detected by indoor unit

Wireless remote controller Beeper sounds/OPERATION INDICATOR lamp blinks (Number of times)	Wired remote controller Check code	Symptom	Remark
1	P1	Intake sensor error	
2	P2	Pipe (TH2) sensor error	
	P9	Pipe (TH5) sensor error	
3	E6, E7	Indoor/outdoor unit communication error	
4	P4	Float switch connector open	
	P5	Drain pump error	
5	PA	Forced compressor stop (due to water leakage abnormality)	
6	P6	Freezing/Overheating protection operation	
7	EE	Communication error between indoor and outdoor units	
8	P8	Pipe temperature error	
9	E4	Remote controller signal receiving error	
10	—	—	
11	—	—	
12	Fb	Indoor unit control system error (memory error, etc.)	
No sound	E0, E3	Remote controller transmission error	
No sound	E1, E2	Remote controller control board error	
No sound	—	No corresponding	

## 7. Test run

[Output pattern B] Errors detected by unit other than indoor unit (outdoor unit, etc.)

Wireless remote controller	Wired remote controller	Symptom	Remark
Beeper sounds/OPERATION INDICATOR lamp blinks (Number of times)	Check code		
1	E9	Indoor/outdoor unit communication error (Transmitting error) (Outdoor unit)	For details, check the LED display of the outdoor controller board.
2	UP	Compressor overcurrent interruption	
3	U3, U4	Open/short of outdoor unit thermistors	
4	UF	Compressor overcurrent interruption (When compressor locked)	
5	U2	Abnormal high discharging temperature/49C worked/insufficient refrigerant	
6	U1, Ud	Abnormal high pressure (63H worked)/Overheating protection operation	
7	U5	Abnormal temperature of heat sink	
8	U8	Outdoor unit fan protection stop	
9	U6	Compressor overcurrent interruption/Abnormal of power module	
10	U7	Abnormality of super heat due to low discharge temperature	
11	U9, UH	Abnormality such as overvoltage or voltage shortage and abnormal synchronous signal to main circuit/Current sensor error	
12	—	—	
13	—	—	
14	Others	Other errors (Refer to the technical manual for the outdoor unit.)	

\*1. If the beeper does not sound again after the initial 2 beeps to confirm the self-check start signal was received and the OPERATION INDICATOR lamp does not come on, there are no error records.

\*2. If the beeper sounds 3 times continuously “beep, beep, beep (0.4 + 0.4 + 0.4 sec.)” after the initial 2 beeps to confirm the self-check start signal was received, the specified refrigerant address is incorrect.

- On wireless remote controller  
The continuous buzzer sounds from receiving section of indoor unit.  
Blink of operation lamp
- On wired remote controller  
Check code displayed in the LCD.

- If the unit cannot be operated properly after test run, refer to the following table to find the cause.

Symptom		Cause
Wireless remote controller	LED 1, 2 (PCB in outdoor unit)	
PLEASE WAIT	For about 2 minutes after power-on	After LED 1, 2 are lighted, LED 2 is turned off, then only LED 1 is lighted. (Correct operation) • For about 2 minutes after power-on, operation of the remote controller is not possible due to system start-up. (Correct operation)
PLEASE WAIT → Error code	Subsequent to about 2 minutes after power-on	Only LED 1 is lighted. → LED 1, 2 blink. • Connector for the outdoor unit's protection device is not connected. Reverse or open phase wiring for the outdoor unit's power terminal block (L1, L2, L3)
Display messages do not appear even when operation switch is turned ON (operation lamp does not light up).		Only LED 1 is lighted. → LED 1 blinks twice, LED 2 blinks once. • Incorrect wiring between indoor and outdoor units (incorrect polarity of S1, S2, S3) • Remote controller wire short

On the wireless remote controller with condition above, following phenomena take place.

- No signals from the remote controller are accepted.
- Operation lamp is blinking.
- The buzzer makes a short ping sound.

**Note:**

**Operation is not possible for about 30 seconds after cancellation of function selection. (Correct operation)**

For description of each LED (LED1, 2, 3) provided on the indoor controller, refer to the following table.

LED 1 (power for microcomputer)	Indicates whether control power is supplied. Make sure that this LED is always lit.
LED 2 (power for remote controller)	Indicates whether power is supplied to the remote controller. This LED lights only in the case of the indoor unit which is connected to the outdoor unit refrigerant address “0”.
LED 3 (communication between indoor and outdoor units)	Indicates state of communication between the indoor and outdoor units. Make sure that this LED is always blinking.

## 8. Easy maintenance function (For PUHZ-(H)RP application only)

Display example (Comp discharge temperature 64°C)

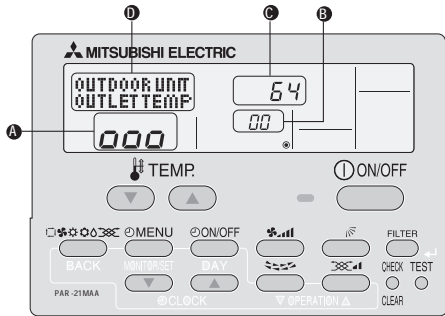

By using the maintenance mode, you can display many types of maintenance data on the remote controller such as the heat exchanger temperature and compressor current consumption for the indoor and outdoor units.

This function can be used whether the air conditioner is operating or not.

During air conditioner operation, data can be checked during either normal operation or maintenance mode stable operation.

\* This function cannot be used during the test run.

\* The availability of this function depends on the connecting outdoor unit. Refer to the brochures.

### Maintenance mode operation procedures

