



SPLIT-TYPE, HEAT PUMP AIR CONDITIONERS
SPLIT-TYPE, AIR CONDITIONERS

March 2009

No. OCB453

PARTS CATALOG

Series PKA Wall Mounted

R410A

Indoor unit

[Model names] [Service Ref.]

PKA-RP35HAL

PKA-RP35HAL

PKA-RP50HAL

PKA-RP50HAL

NOTE:

- RoHS compliant products have <G> mark on the spec name plate.

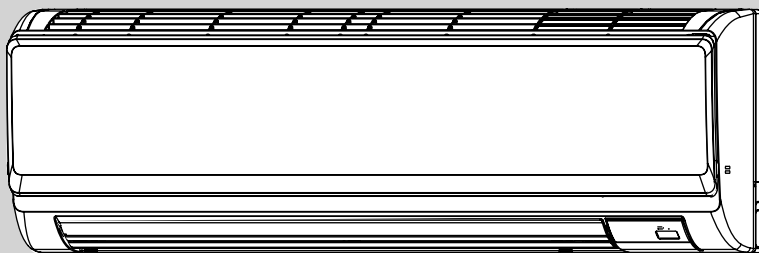

INDOOR UNIT

CONTENTS

1. RoHS PARTS LIST2

SERVICE MANUAL (OCH453)

PANEL AND HEAT EXCHANGER PARTS

PKA-RP35HAL

PKA-RP50HAL

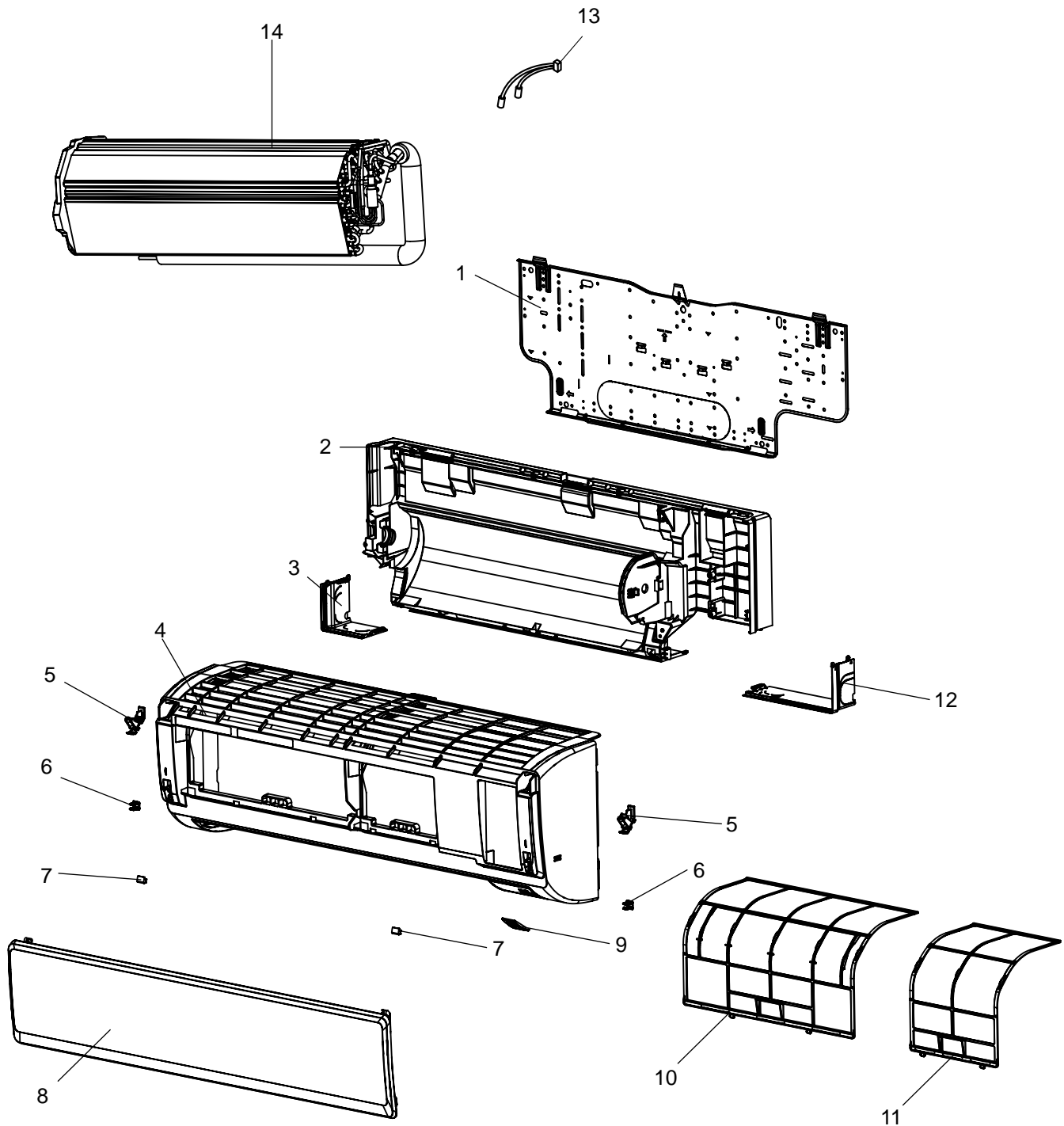

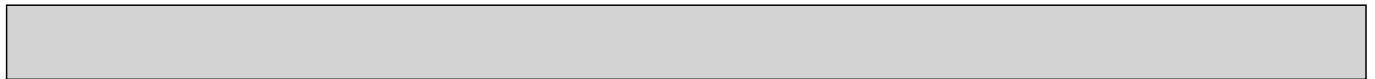

No.	RoHS	Part No.	Part Name	Specification	Q'ty/set		Remarks (Drawing No.)	Wiring Diagram Symbol	Recom- mended Q'ty
					PKA-RP-HAL				
					35	50			
1	G	R01 E08 808	BACK PLATE		1	1			
2	G	R01 E02 635	BOX ASSY		1	1			
3	G	R01 E30 658	CORNER BOX (L)		1	1			
4	G	R01 E15 651	FRONT PANEL		1	1			
5	G	R01 E14 054	HOLDER (R.L)		1	1	2pcs/set		
6	G	R01 E15 054	CATCH		1	1	2pcs/set		
7	G	R01 E05 096	SCREW CAP		1	1	2pcs/set		
8	G	R01 E58 691	GRILLE		1	1			
9	G	R01 E31 658	RECEIVER COVER		1	1			
10	G	R01 E27 500	FILTER		1	1			
11	G	R01 E28 500	FILTER		1	1			
12	G	R01 E29 658	CORNER BOX (R)		1	1			
13	G	R01 N17 202	THERMISTOR		1	1		TH2/5	
14	G	T7W N08 480	HEAT EXCHANGER		1	1			

FAN AND ELECTRICAL PARTS
PKA-RP35HAL
PKA-RP50HAL

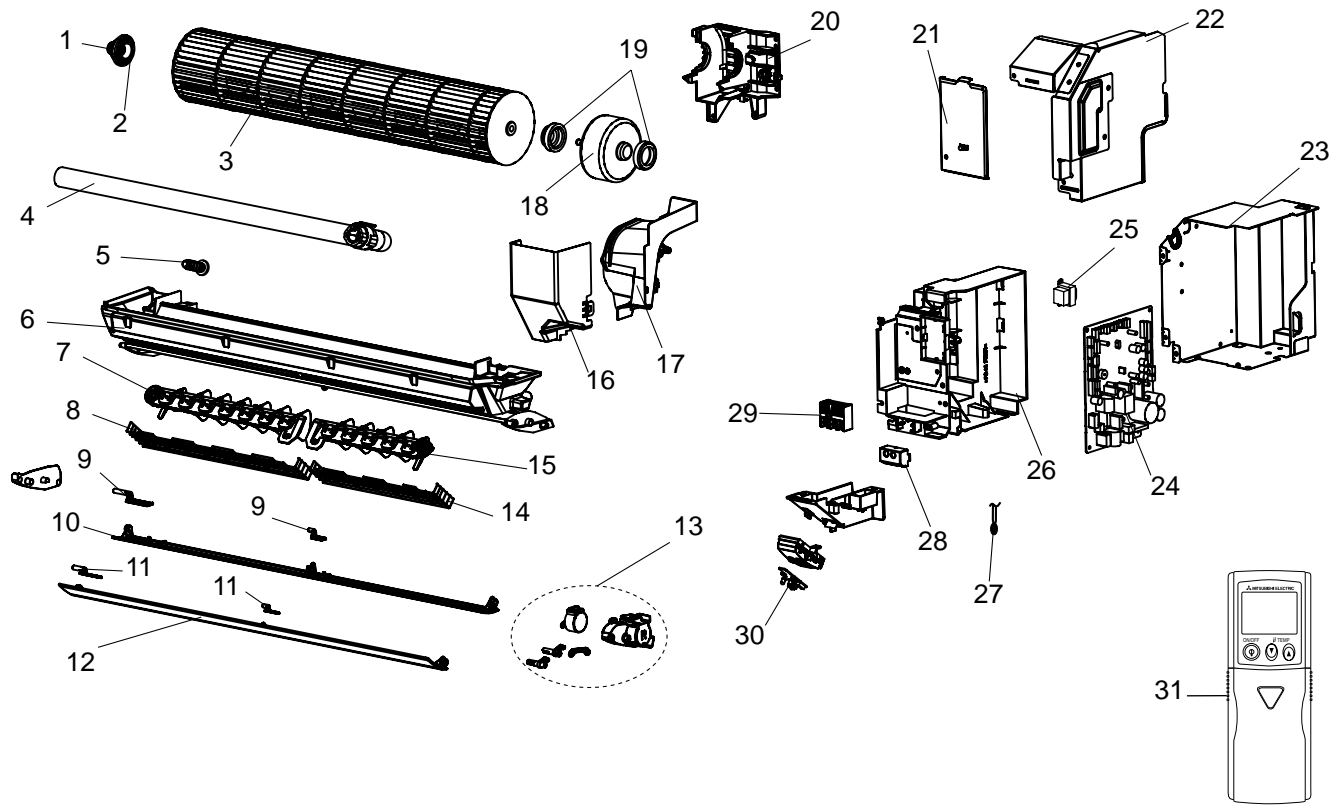



Part numbers that are circled are not shown in the illustration.

No.	RoHS	Part No.	Part Name	Specification	Q'ty/set		Remarks (Drawing No.)	Wiring Diagram Symbol	Recom- mended Q'ty
					PKA-RP-HAL				
					35, 50				
1	G	R01 E01 102	BEARING MOUNT			1			
2	G	R01 E04 103	SLEEVE BEARING			1			
3	G	R01 E42 114	LINEFLOW FAN			1			
4	G	R01 E09 527	DRAIN HOSE			1			
5	G	R01 E03 524	DRAIN CAP			1			
6	G	R01 E01 530	NOZZLE ASSY			1	with No.7,15		
7	G	R01 E07 038	GUIDE VANE ASSY-L			1			
8	G	T7W E19 675	FAN GUARD-L			1			
9	G	R01 E06 063	VANE SHAFT-UC			1	2pcs/set		
10	G	R01 E32 002	AUTO VANE-U			1			
11	G	R01 E05 063	VANE SHAFT-TC			1	2pcs/set		
12	G	R01 E31 002	AUTO VANE-T			1			
13	G	R01 E27 223	VANE MOTOR			1		M	
14	G	T7W E18 675	FAN GUARD-R			1			
15	G	R01 E06 038	GUIDE VANE ASSY-R			1			
16	G	R01 E00 031	WATER COVER			1			
17	G	R01 E03 126	MOTOR BAND			1			
18	G	R01 E51 220	FAN MOTOR			1	with No.19	MF	
19	G	R01 E18 105	RUBBER MOUNT			1			
20	G	R01 E44 130	MOTOR BED			1			
21	G	—	TOP COVER			1	(BK02B838G03)		
22	G	—	SIDE COVER			1	(BK02A479G28)		
23	G	—	CONTROL BOX			1	(BK00B899G04)		
24	G	T7W E86 310	CONTROLLER BOARD			1		I.B, S.B	
25	G	T7W E19 259	REACTOR			1		DCL	
26	G	—	PB BOX			1	(BK25A475G05)		
27	G	R01 N20 202	THERMISTOR			1	with tube & band	TH1	
28	G	R01 E01 031	SWITCH BOARD COVER			1			
29	G	T7W E54 716	TERMINAL BLOCK	3P(S1, S2, S3)		1		TB4	
30	G	R01 E10 317	RECEIVER ASSY			1		W.B	
31	G	—	WIRELESS REMOTE CONTROLLER	PAR-FL32MA		1			
32	G	R01 E11 239	FUSE	3.15A 250V		1		FUSE	
33	G	R01 E12 304	CABLE (VANE MOTOR)			1			





Mr. SLIM™

 **mitsubishi electric corporation**
HEAD OFFICE : TOKYO BLDG., 2-7-3, MARUNOUCHI, CHIYODA-KU TOKYO 100-8310, JAPAN