



SPLIT-TYPE, HEAT PUMP AIR CONDITIONERS
SPLIT-TYPE, AIR CONDITIONERS

February 2009

No. OCB452

PARTS CATALOG

Series PKA Wall Mounted R410A

Indoor unit
[Model names]

[Service Ref.]

PKA-RP60KAL

PKA-RP71KAL

PKA-RP100KAL

PKA-RP60KAL.TH
PKA-RP71KAL.TH
PKA-RP100KAL.TH

Note:

- RoHS compliant products have <G> mark on the spec name plate.

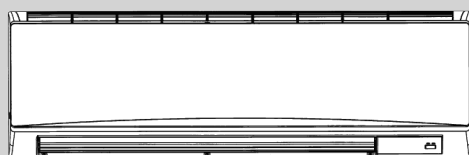

INDOOR UNIT



WIRELESS REMOTE CONTROLLER

CONTENTS

1. RoHS PARTS LIST	2
--------------------------	---

SERVICE MANUAL (OCH452)



PANEL AND HEAT EXCHANGER PARTS

PKA-RP60KAL.TH

PKA-RP71KAL.TH

PKA-RP100KAL.TH

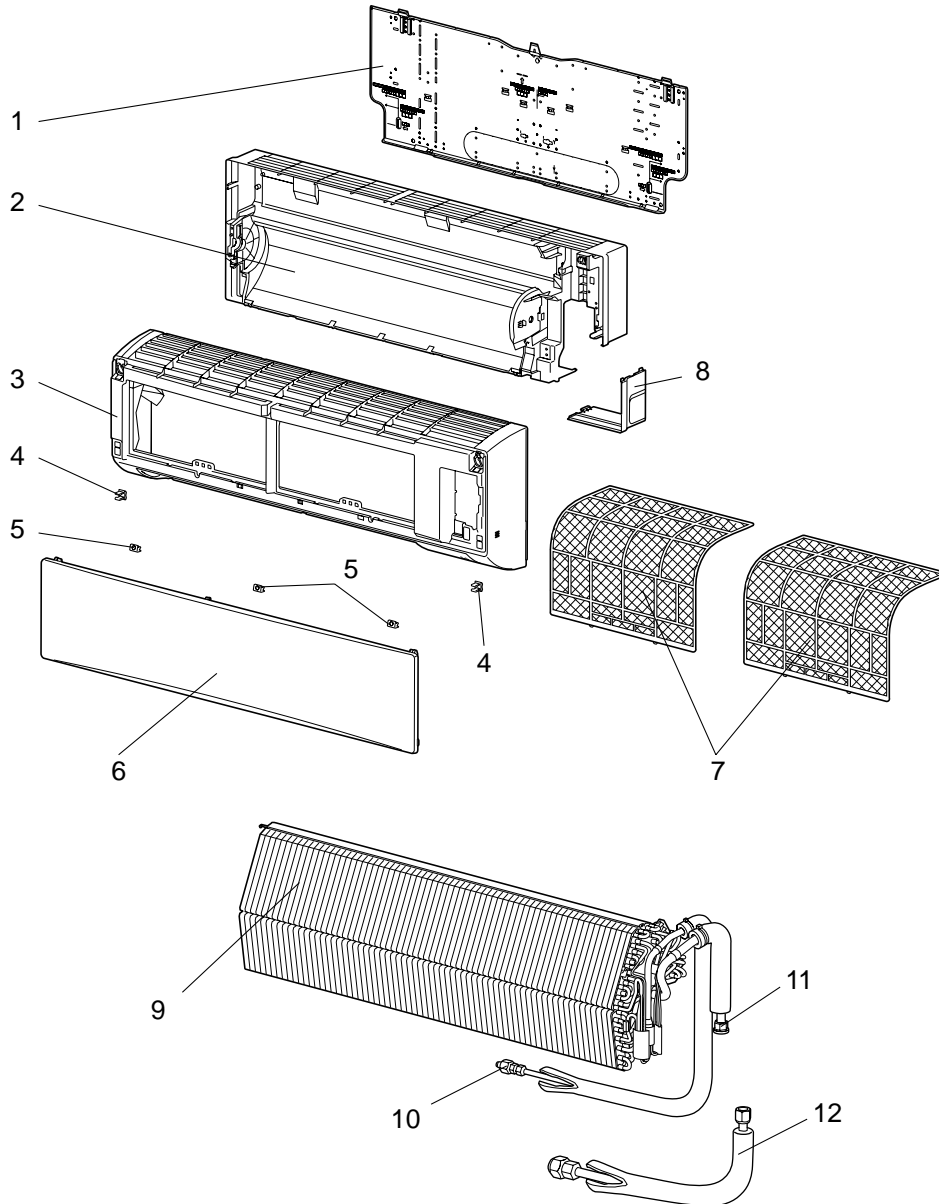



No.	RoHS	Part No.	Part Name	Specification	Q'ty/set		Remarks (Drawing No.)	Wiring Diagram Symbol	Recom- mended Q'ty
					PKA-RP•KAL.TH				
					60, 71	100			
1	G	E12 C92 970	INSTALLATION PLATE		1	1			
2	G	E12 C92 234	BOX		1	1			
3	G	E17 518 000	PANEL ASSEMBLY		1	1			
4	G	E12 408 142	CATCH		1	1	2pcs/set		
5	G	E12 C92 067	SCREW CAP		1	1	3pcs/set		
6	G	E12 C92 010	FRONT PANEL (NW)		1	1			
7	G	E12 C92 100	CATECHIN AIR FILTER		2	2			
8	G	E12 C92 975	CORNER BOX R		1	1			
9	G	E17 520 620	HEAT EXCHANGER		1				
	G	E17 522 620	HEAT EXCHANGER			1			
10	G	E12 527 667	UNION (LIQ)		1	1			
11	G	E12 C92 666	UNION (GAS)		1	1			
12	G	E17 518 980	JOINT ASSEMBLY		1	1			

FUNCTIONAL PARTS
PKA-RP60KAL.TH
PKA-RP71KAL.TH
PKA-RP100KAL.TH

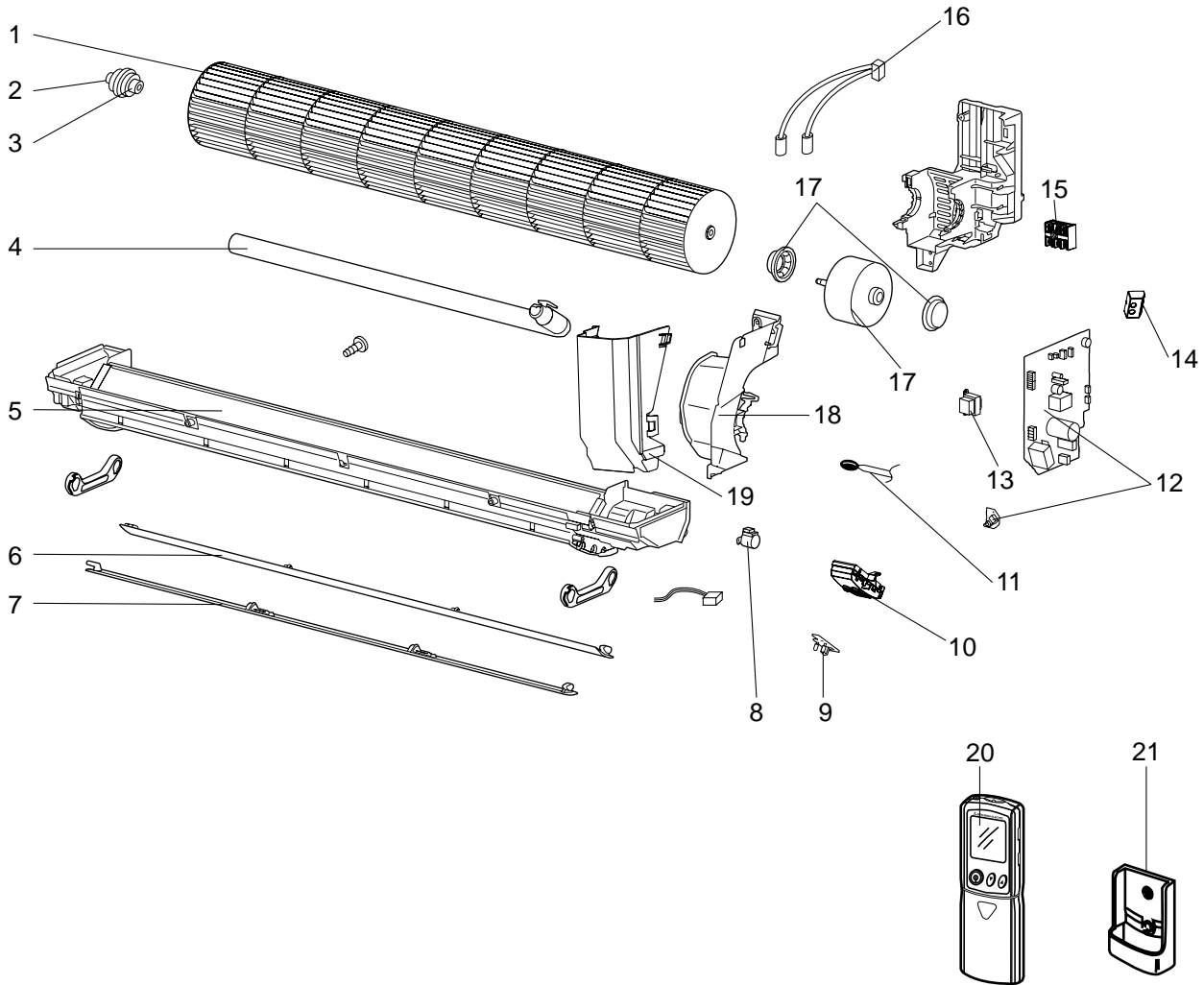



Part numbers that are circled are not shown in the illustration.

No.	RoHS	Part No.	Part Name	Specification	Q'ty/set		Remarks (Drawing No.)	Wiring Diagram Symbol	Recom- mended Q'ty
					PKA-RP60, 71, 100				
					KAL.TH				
1	G	E12 C92 302	LINE FLOW FAN			1			
2	G	E12 751 509	BEARING MOUNT			1			
3	G	E12 001 504	SLEEVE BEARING			1			
4	G	E12 408 702	DRAIN HOSE			1			
5	G	E17 518 235	NOZZLE ASSEMBLY			1			
6	G	E12 C92 040	VANE UPPER			1			
7	G	E12 C92 041	VANE LOWER			1			
8	G	E12 749 303	VANE MOTOR			1		MV	
9	G	E17 518 468	RECEIVER P.C.BOARD			1		W.B.	
10	G	E12 C92 095	RECEIVER HOLDER			1			
11	G	E17 518 308	ROOM TEMP. THERMISTOR			1		TH1	
12	G	E17 489 447	INDOOR CONTROLLER BOARD			1		I.B., S.W.	
13	G	E17 489 337	REACTOR			1		DCL	
14	G	E17 518 782	SWITCH HOLDER			1			
15	G	E17 489 375	TERMINAL BLOCK	3P (S1,S2,S3)		1		TB4	
16	G	E17 491 307	THERMISTOR (PIPE)			1		TH2,TH5	
17	G	E12 C92 300	FAN MOTOR			1		MF	
18	G	E12 C92 333	MOTOR BAND			1			
19	G	E17 518 541	WATER COVER			1			
20	G	E17 489 426	WIRELESS REMOTE CONTROLLER			1			
21	G	E17 489 083	REMOTE CONTROLLER HOLDER			1			
22	G	E12 A49 382	FUSE	3.15A 250V		1		FUSE	

Mr. SLIM™

 **mitsubishi ELECTRIC CORPORATION**

HEAD OFFICE : TOKYO BLDG., 2-7-3, MARUNOUCHI, CHIYODA-KU TOKYO 100-8310, JAPAN