

Air-Conditioners

SUZ-KA25, KA35, KA50, KA60, KA71VA2 SUZ-KA25, KA35VAH

INSTALLATION MANUAL

For safe and correct use, read this manual and the indoor unit installation manual thoroughly before installing the air-conditioner unit.

FOR INSTALLER

INSTALLATIONSHANDBUCH

Aus Sicherheitsgründen und zur richtigen Verwendung vor der Installation die vorliegende Bedienungsanleitung und die Installationsanleitung der Innenanlage gründlich durchlesen die Klimaanlage.

FÜR INSTALLATEURE

MANUEL D'INSTALLATION

Avant d'installer le climatiseur, lire attentivement ce manuel, ainsi que le manuel d'installation de l'appareil intérieur pour une utilisation sûre et correcte.

POUR L'INSTALLATEUR

INSTALLATIEHANDLEIDING

Lees deze handleiding en de installatiehandleiding van het binnenapparaat zorgvuldig door voordat u met het installeren van de airconditioner begint.

VOOR DE INSTALLATEUR

MANUAL DE INSTALACIÓN

Para un uso correcto y seguro, lea detalladamente este manual y el manual de instalación de la unidad interior antes de instalar la unidad de aire acondicionado.

PARA EL INSTALADOR

MANUALE DI INSTALLAZIONE

Per un uso sicuro e corretto, leggere attentamente il presente manuale ed il manuale d'installazione dell'unità interna prima di installare il condizionatore d'aria.

PER L'INSTALLATORE

ΕΓΧΕΙΡΙΔΙΟ ΟΔΗΓΙΩΝ ΕΓΚΑΤΑΣΤΑΣΗΣ

Για σωστή και ασφαλή χρήση, διαβάστε προσεκτικά αυτό το εγχειρίδιο καθώς και το εγχειρίδιο εγκατάστασης της εσωτερικής μονάδας, προτού εγκαταστήσετε τη μονάδα του κλιματιστικού.

ΓΙΑ ΑΥΤΟΝ ΠΟΥ ΚΑΝΕΙ ΤΗΝ ΕΓΚΑΤΑΣΤΑΣΗ

MANUAL DE INSTALAÇÃO

Para uma utilização segura e correcta, leia atentamente este manual e o manual de instalação da unidade interior antes de instalar o aparelho de ar condicionado.

PARA O INSTALADOR

INSTALLATIONSMANUAL

Læs af sikkerhedshensyn denne manual samt manualen til installation af indendørsenheden grundigt, før du installerer klimaanlægget.

TIL INSTALLATØREN

INSTALLATIONSMANUAL

Läs bruksanvisningen och inomhusenhetens installationshandbok noga innan luftkonditioneringen installeras så att den används på ett säkert och korrekt sätt.

FÖR INSTALLATÖREN

MONTAJ ELKİTABI

Emniyetli ve doğru kullanım için, klima cihazını monte etmeden önce bu kılavuzu ve iç ünite montaj kılavuzunu tamamiyla okuyun.

MONTÖR İÇİN

РУКОВОДСТВО ПО УСТАНОВКЕ

Для обеспечения безопасной и надлежащей эксплуатации внимательно прочтите данное руководство и руководство по установке внутреннего прибора перед установкой кондиционера.

ДЛЯ УСТАНОВИТЕЛЯ**English****Deutsch****Français****Nederlands****Español****Italiano****Ελληνικά****Português****Dansk****Svenska****Türkçe****Русский**

Contents

1. The following should always be observed for safety	2
2. Selecting the installation location	2
3. Installation diagram	3
4. Drain piping for outdoor unit	3
5. Refrigerant piping work	4
6. Electrical work	6
7. Maintenance	7

1. The following should always be observed for safety

- Please provide an exclusive circuit for the air conditioner and do not connect other electrical appliances to it.
- Be sure to read “The following should always be observed for safety” before installing the air conditioner.
- Be sure to observe the cautions specified here as they include important items related to safety.
- The indications and meanings are as follows.

⚠ Warning:

Could lead to death, serious injury, etc.

⚠ Caution:

Could lead to serious injury in particular environments when operated incorrectly.

⚠ Warning:

- Do not install it by yourself (customer).
Incomplete installation could cause injury due to fire, electric shock, the unit falling or leakage of water. Consult the dealer from whom you purchased the unit or special installer.
- Install the unit securely in a place which can bear the weight of the unit.
When installed in an insufficient strong place, the unit could fall causing injured.
- Use the specified wires to connect the indoor and outdoor units securely and attach the wires firmly to the terminal board connecting sections so the stress of the wires is not applied to the sections.
Incomplete connecting and fixing could cause fire.
- Do not use intermediate connection of the power cord or the extension cord and do not connect many devices to one AC outlet.
It could cause a fire or an electric shock due to defective contact, defective insulation, exceeding the permissible current, etc.
- Check that the refrigerant gas does not leak after installation has completed.
- Perform the installation securely referring to the installation manual.
Incomplete installation could cause a personal injury due to fire, electric shock, the unit falling or leakage of water.

⚠ Caution:

- Perform grounding.
Do not connect the ground wire to a gas pipe, water pipe arrester or telephone ground wire. Defective grounding could cause an electric shock.
- Do not install the unit in a place where an inflammable gas leaks.
If gas leaks and accumulates in the area surrounding the unit, it could cause an explosion.
- Install a ground leakage breaker depending on the installation place (where it is humid).
If a ground leakage breaker is not installed, it could cause an electric shock.

- After reading this manual, be sure to keep it together with the instruction manual in a handy place on the customer's site.

 : Indicates a part which must be grounded.

⚠ Warning:

Carefully read the labels affixed to the main unit.

- Perform electrical work according to the installation manual and be sure to use an exclusive circuit.
If the capacity of the power circuit is insufficient or there is incomplete electrical work, it could result in a fire or an electric shock.
- Attach the electrical part cover to the indoor unit and the service panel to the outdoor unit securely.
If the electrical part cover in the indoor unit and/or the service panel in the outdoor unit are not attached securely, it could result in a fire or an electric shock due to dust, water, etc.
- Be sure to use the part provided or specified parts for the installation work.
The use of defective parts could cause an injury or leakage of water due to a fire, an electric shock, the unit falling, etc.
- Ventilate the room if refrigerant leaks during operation.
If the refrigerant comes in contact with a flame, poisonous gases will be released.
- When pumping down the refrigerant, stop the compressor before disconnecting the refrigerant pipes. The compressor may burst if air etc. get into it.

- Perform the drainage/piping work securely according to the installation manual.
If there is a defect in the drainage/piping work, water could drop from the unit and household goods could be wet and damaged.
- Fasten a flare nut with a torque wrench as specified in this manual.
When fastened too tight, a flare nut may broken after a long period and cause a leakage of refrigerant.

2. Selecting the installation location

2.1. Outdoor unit

- Where it is not exposed to strong wind.
- Where airflow is good and dustless.
- Where it is not exposed to rain and direct sunshine.
- Where neighbours are not annoyed by operation sound or hot air.
- Where rigid wall or support is available to prevent the increase of operation sound or vibration.
- Where there is no risk of combustible gas leakage.
- When installing the unit at a high level, be sure to fix the unit legs.
- Where it is at least 3 m away from the antenna of TV set or radio. (Otherwise, images would be disturbed or noise would be generated.)
- Please install it in an area not affected by snowfall or blowing snow. In areas with heavy snow, please install a canopy, a pedestal and/or some baffle boards.
- Install the unit horizontally.

⚠ Caution:

Avoid the following places for installation where air conditioner trouble is liable to occur.

- Where there is too much machine oil.
- Salty environment as seaside areas.
- Hot-spring areas.
- Where sulfide gas exists.
- Other special atmospheric areas.

The outdoor unit produces condensate during the heating operation. Select the installation place to ensure to prevent the outdoor unit and/or the grounds from being wet by drain water or damaged by frozen drain water.

3. Installation diagram

■ SUZ-KA25/KA35VA2 SUZ-KA25/KA35VAH

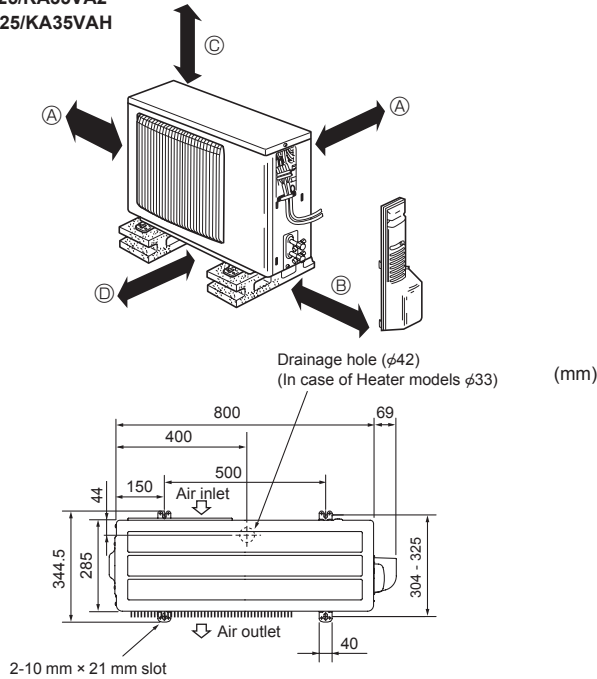

3.1. Outdoor unit (Fig. 3-1)

Ventilation and service space

■ SUZ-KA25/KA35VA2 SUZ-KA25/KA35VAH

- Ⓐ 100 mm or more
- Ⓑ 350 mm or more
- Ⓒ Basically open 100 mm or more without any obstruction in front and on both sides of the unit.
- Ⓓ 200 mm or more (Open two sides of left, right, or rear side.)

■ SUZ-KA50/KA60/KA71VA2

- Ⓐ 100 mm or more
- Ⓑ 350 mm or more
- Ⓒ 500 mm or more

When the piping is to be attached to a wall containing metals (tin plated) or metal netting, use a chemically treated wooden piece 20 mm or thicker between the wall and the piping or wrap 7 to 8 turns of insulation vinyl tape around the piping.

Units should be installed by licensed contractor accordingly to local code requirement.

Note:

When operating the air conditioner in low outside temperature, be sure to follow the instructions described below.

- Never install the outdoor unit in a place where its air inlet/outlet side may be exposed directly to wind.
- To prevent exposure to wind, install the outdoor unit with its air inlet side facing the wall.
- To prevent exposure to wind, it is recommended to install a baffle board on the air outlet side of the outdoor unit.

■ SUZ-KA50/KA60VA2

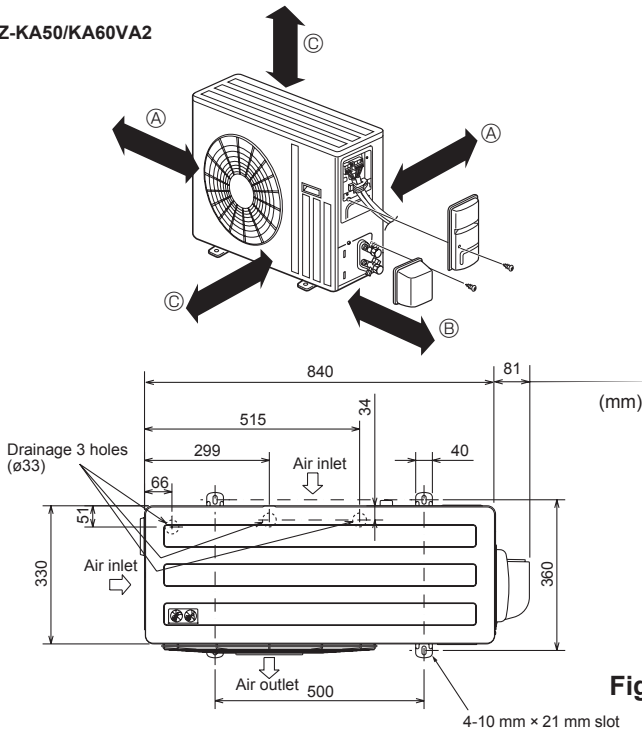

■ SUZ-KA71VA2

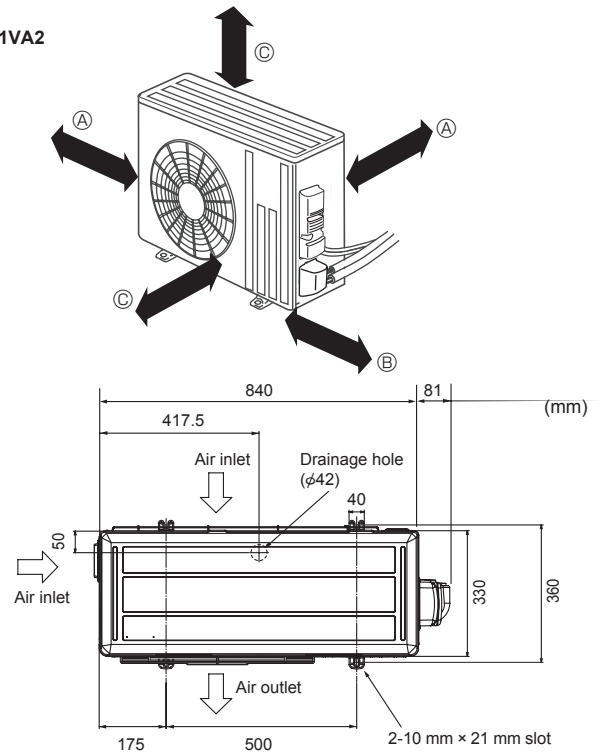

Fig. 3-1

4. Drain piping for outdoor unit (Fig. 4-1)

■ SUZ-KA25/35VA2

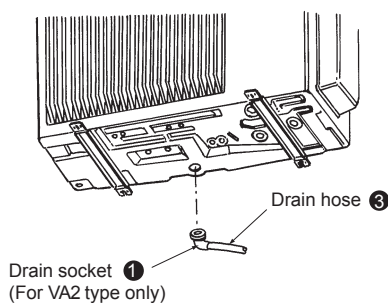

Fig. 4-1

4.1. Accessories

Check the following parts before installation.

<Outdoor unit>

①	Drain socket (for VA2 type only)	1
②	Drain cap ø33 (for SUZ-KA50/KA60 only)	2

- Provide drain piping before indoor and outdoor piping connection. (It will be hard to install drain socket ① if indoor and outdoor piping connection is conducted prior to drain piping as outdoor unit becomes immovable.)
- Connect the drain hose ③ (obtainable at a store, inside diameter: 15 mm) as shown in the figure for drainage.
- Make sure to provide drain piping with a downhill grade for easy drain flow.

Note:

Do not use the drain socket ① in the cold region. Drain may freeze and it makes the fan stop.

5. Refrigerant piping work

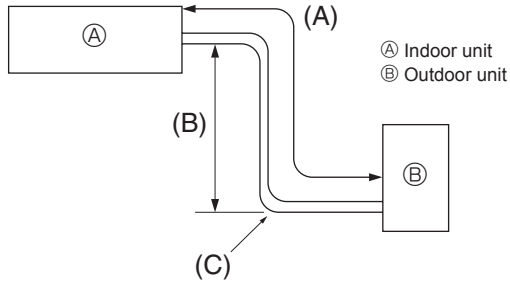

Fig. 5-1

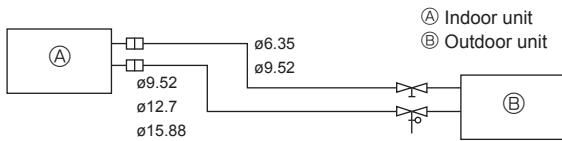

Fig. 5-2

5.1. Refrigerant pipe (Fig. 5-1)

► Check that the difference between the heights of the indoor and outdoor units, the length of refrigerant pipe, and the number of bends in the pipe are within the limits shown below.

Models	(A) Pipe length (one way)	(B) Height difference	(C) Number of bends (one way)
SUZ-KA25/KA35	Max. 20 m	Max. 12 m	Max. of 10
SUZ-KA50/KA60/KA71	Max. 20 m	Max. 30 m *(15 m)	Max. of 10

*(): MFZ

- Height difference limitations are binding regardless of which unit, indoor or outdoor, is positioned higher.
- Refrigerant adjustment ... If pipe length exceeds 7 m, additional refrigerant (R410A) charge is required.
(The outdoor unit is charged with refrigerant for pipe length up to 7 m.)

Pipe length	Up to 7 m	No additional charge is required.
	Exceeding 7 m	Additional charge is required. (Refer to the table below.)
Refrigerant to be added	SUZ-KA25/KA35 type	30 g × (refrigerant piping length (m) -5)
	SUZ-KA50/KA60 type	20 g × (refrigerant piping length (m) -7)
	SUZ-KA71 type	55 g × (refrigerant piping length (m) -7)

Piping preparation

- Refrigerant pipes of 3, 5, 7, 10 and 15 m are available as optional items.

(1) Table below shows the specifications of pipes commercially available.

Model	Pipe	Outside diameter		Min. wall thickness	Insulation thickness	Insulation material
		mm	inch			
SUZ-KA25	For liquid	6.35	1/4	0.8 mm	8 mm	Heat resisting foam plastic 0.045 specific gravity
	For gas	9.52	3/8	0.8 mm	8 mm	
SUZ-KA35	For liquid	6.35	1/4	0.8 mm	8 mm	
	For gas	9.52	3/8	0.8 mm	8 mm	
SUZ-KA50	For liquid	6.35	1/4	0.8 mm	8 mm	
	For gas	12.7	1/2	0.8 mm	8 mm	
SUZ-KA60	For liquid	6.35	1/4	0.8 mm	8 mm	
	For gas	15.88	5/8	0.8 mm	8 mm	
SUZ-KA71	For liquid	9.52	3/8	0.8 mm	8 mm	
	For gas	15.88	5/8	1.0 mm	8 mm	

- (2) Ensure that the 2 refrigerant pipes are well insulated to prevent condensation.
 (3) Refrigerant pipe bending radius must be 100 mm or more.

⚠ Caution:

Using careful insulation of specified thickness. Excessive thickness prevents storage behind the indoor unit and smaller thickness causes dew drippage.

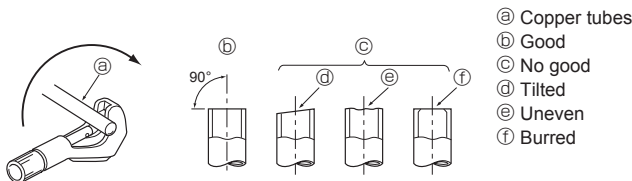

Fig. 5-3

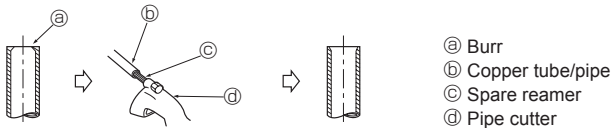

Fig. 5-4

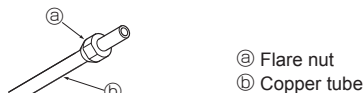

Fig. 5-5

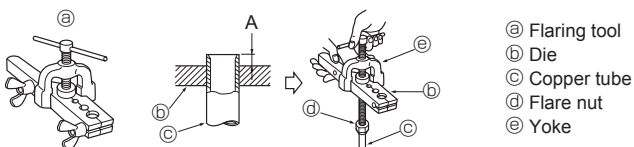

Fig. 5-6

5.2. Flaring work

- Main cause of gas leakage is defect in flaring work.
Carry out correct flaring work in the following procedure.

5.2.1. Pipe cutting (Fig. 5-3)

- Using a pipe cutter cut the copper tube correctly.

5.2.2. Burrs removal (Fig. 5-4)

- Completely remove all burrs from the cut cross section of pipe/tube.
- Put the end of the copper tube/pipe to downward direction as you remove burrs in order to avoid burrs drop in the tubing.

5.2.3. Putting nut on (Fig. 5-5)

- Remove flare nuts attached to indoor and outdoor unit, then put them on pipe/tube having completed burr removal.
(not possible to put them on after flaring work)

5.2.4. Flaring work (Fig. 5-6)

- Carry out flaring work using flaring tool as shown at the right.

Pipe diameter (mm)	Dimension	
	A (mm)	B ⁺⁰ _{-0.4} (mm)
	When the tool for R410A is used Clutch type	
6.35	0 - 0.5	9.1
9.52	0 - 0.5	13.2
12.7	0 - 0.5	16.6
15.88	0 - 0.5	19.7

Firmly hold copper tube in a die in the dimension shown in the table at above.

5. Refrigerant piping work

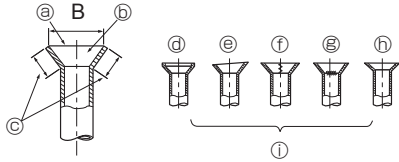

Fig. 5-7

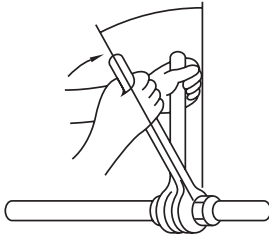

Fig. 5-8

5.2.5. Check (Fig. 5-7)

- Compare the flared work with a figure in right side hand.
- If flare is noted to be defective, cut off the flared section and do flaring work again.

- Ⓐ Smooth all around
- Ⓑ Inside is shining without any scratches
- Ⓒ Even length all around
- Ⓓ Too much
- Ⓔ Tilted
- Ⓣ Scratch on flared plane
- Ⓤ Cracked
- Ⓢ Uneven
- Ⓦ Bad examples

- Apply a thin coat of refrigeration oil on the seat surface of pipe. (Fig. 5-8)
- For connection first align the center, then tighten the first 3 to 4 turns of flare nut.
- Use tightening torque table below as a guideline for indoor unit side union joint section, and tighten using two wrenches. Excessive tightening damages the flare section.

Copper pipe O.D. (mm)	Flare nut O.D. (mm)	Tightening torque (N·m)
ø6.35	17	14 - 18
ø9.52	22	34 - 42
ø12.7	26	49 - 61
ø15.88	29	68 - 82

Warning:
When installing the unit, securely connect the refrigerant pipes before starting the compressor.

Warning:
Be careful of flying flare nut! (Internally pressurized)
Remove the flare nut as follows:

1. Loosen the nut until you hear a hissing noise.
2. Do not remove the nut until the gas has been completely released (i.e., hissing noise stops).
3. Check that the gas has been completely released, and then remove the nut.

5.5. Purging procedures leak test

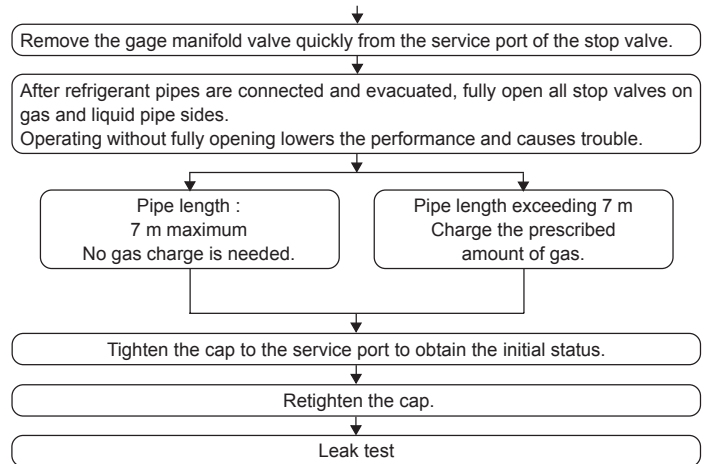
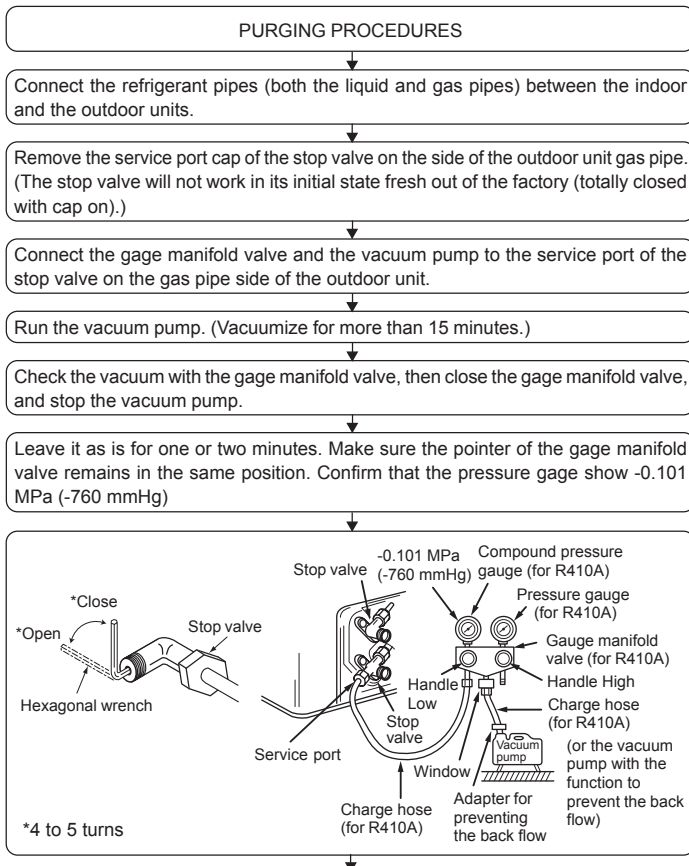

6. Electrical work

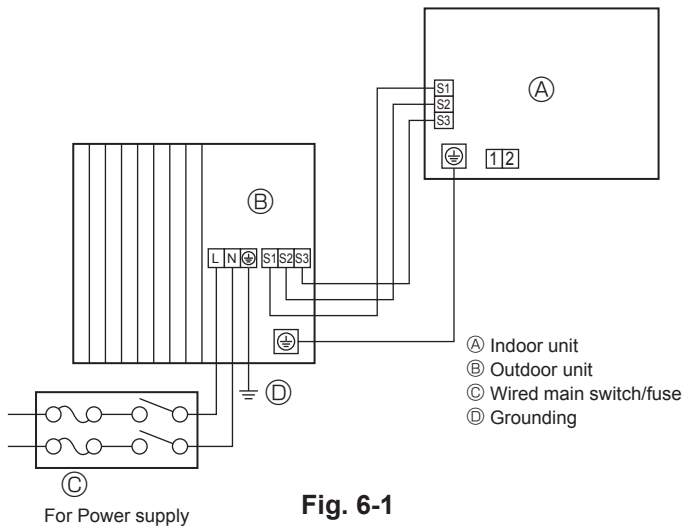

Fig. 6-1

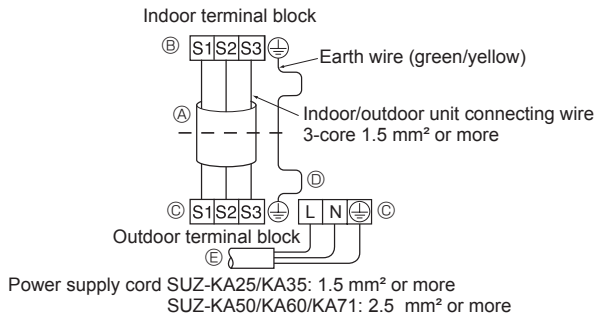

Fig. 6-2

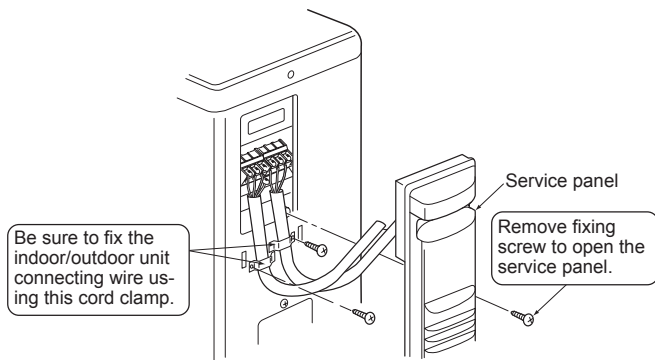

Fig. 6-3

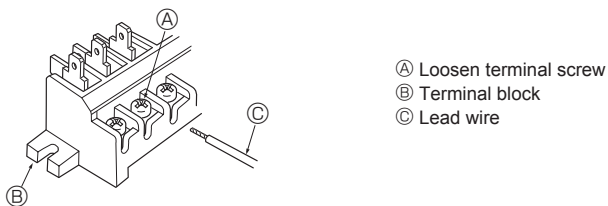

Fig. 6-4

6.1. Outdoor unit (Fig. 6-1, Fig. 6-2, Fig. 6-3, Fig. 6-4)

- ① Remove the service panel.
- ② Wire the cables referring to the Fig. 6-1, Fig. 6-2, Fig. 6-3 and the Fig. 6-4.

- Perform wiring as shown in the diagram to the lower left. (Procure the cable locally) (Fig. 6-2)

Make sure to use cables of the correct polarity only.

- (A) Connecting cable
- (B) Indoor terminal block
- (C) Outdoor terminal block
- (D) Always install an earth wire longer than other cables.
- (E) Power supply cord

⚠ Caution:

- Use care not to make miswiring.
- Firmly tighten the terminal screws to prevent them from loosening.
- After tightening, pull the wires lightly to confirm that they do not move.

- Connect cable from the indoor unit correctly on the terminal-block.
- Use the same terminal block and polarity as is used with the indoor unit.
- For aftercare maintenance, give extra length to connecting cable.

- Both end of connecting cable (extension wire) are peeled off. When too long, or connected by cutting off the middle, peel off power supply cable to the size given in the figure.
- Be careful not to contact connecting cable with piping.

⚠ Caution:

- Use care not to make miswiring. (Fig. 6-4)
- Firmly tighten the terminal screws to prevent them from loosening.
- After tightening, pull the wires lightly to confirm that they do not move.

⚠ Warning:

- Be sure to attach the service panel of the outdoor unit securely. If it is not attached correctly, it could result in a fire or an electric shock due to dust, water, etc.
- Tighten terminal screws securely.
- Wiring should be done so that the power lines are not subject to tension. Otherwise, heat may be generated or fire may occur.

6. Electrical work

6.2. Field electrical wiring

Outdoor unit model		SUZ-KA25/KA35	SUZ-KA35 *3	SUZ-KA50/KA60/KA71
Outdoor unit power supply		~/N (single), 50 Hz, 230 V	~/N (single), 50 Hz, 230 V	~/N (single), 50 Hz, 230 V
Outdoor unit input capacity Main switch (Breaker)		*1 10 A	16 A	20 A
Wiring Wire No. x Wire size (mm ²)	Outdoor unit power supply	2 x Min. 1.5	2 x Min. 2.0	2 x Min. 2.5
	Outdoor unit power supply earth	1 x Min. 1.5	1 x Min. 2.0	1 x Min. 2.5
	Indoor unit-Outdoor unit	3 x 1.5 (Polar)	3 x 1.5 (Polar)	3 x 1.5 (Polar)
	Indoor unit-Outdoor unit earth	1 x Min. 1.5	1 x Min. 1.5	1 x Min. 1.5
Circuit rating	Outdoor unit L-N	*2 AC 230 V	AC 230 V	AC 230 V
	Indoor unit-Outdoor unit S1-S2	*2 AC 230 V	AC 230 V	AC 230 V
	Indoor unit-Outdoor unit S2-S3	*2 DC 12 V ~ DC 24 V	DC 12 V ~ DC 24 V	DC 12 V ~ DC 24 V

*1. A breaker with at least 3 mm contact separation in each pole shall be provided. Use earth leakage breaker (NV).

*2. The figures are NOT always against the ground.

S3 terminal has DC 24 V against S2 terminal. However between S3 and S1, these terminals are NOT electrically insulated by the transformer or other device.

*3. In case of PEAD-RP35JA series combination.

Notes: 1. Wiring size must comply with the applicable local and national code.

2. Power supply cords and Indoor/Outdoor unit connecting cords shall not be lighter than polychloroprene sheathed flexible cord. (Design 60245 IEC 57)

3. Install an earth longer than other cables.

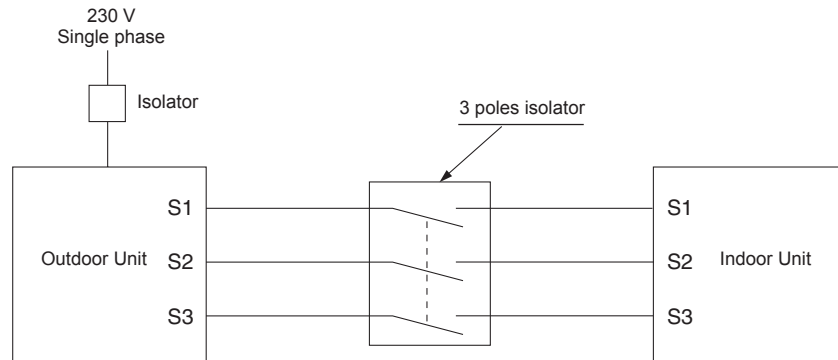

⚠ Warning:

There is high voltage potential on the S3 terminal caused by electrical circuit design that has no electrical insulation between power line and communication signal line. Therefore, please turn off the main power supply when servicing. And do not touch the S1, S2, S3 terminals when the power is energized. If isolator should be used between indoor unit and outdoor unit, please use 3-poles type.

7. Maintenance

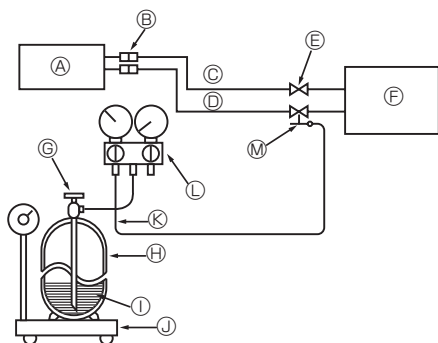

- (A) Indoor unit
- (B) Union
- (C) Liquid pipe
- (D) Gas pipe
- (E) Stop valve
- (F) Outdoor unit
- (G) Refrigerant gas cylinder operating valve
- (H) Refrigerant gas cylinder for R410A with siphon
- (I) Refrigerant (liquid)
- (J) Electronic scale for refrigerant charging
- (K) Charge hose (for R410A)
- (L) Gauge manifold valve (for R410A)
- (M) Service port

Fig. 7-1

7.1. Gas charge (Fig. 7-1)

1. Connect gas cylinder to the service port of stop valve (3-way).
2. Execute air purge of the pipe (or hose) coming from refrigerant gas cylinder.
3. Replenish specified amount of refrigerant, while running the air conditioner for cooling.

Note:

In case of adding refrigerant, comply with the quantity specified for the refrigerating cycle.

⚠ Caution:

- Do not discharge the refrigerant into the atmosphere. Take care not to discharge refrigerant into the atmosphere during installation, reinstallation, or repairs to the refrigerant circuit.
- For additional charging, charge the refrigerant from liquid phase of the gas cylinder. If the refrigerant is charged from the gas phase, composition change may occur in the refrigerant inside the cylinder and the outdoor unit. In this case, ability of the refrigerating cycle decreases or normal operation can be impossible. However, charging the liquid refrigerant all at once may cause the compressor to be locked. Thus, charge the refrigerant slowly.

To maintain the high pressure of the gas cylinder, warm the gas cylinder with warm water (under 40°C) during cold season. But never use naked fire or steam.

This product is designed and intended for use in the residential,
commercial and light-industrial environment.

The product at hand is
based on the following
EU regulations:

- Low Voltage Directive 2006/95/EC
- Electromagnetic Compatibility Directive
2004/108/EC

Please be sure to put the contact address/telephone number on
this manual before handing it to the customer.



HEAD OFFICE: TOKYO BLDG., 2-7-3, MARUNOUCHI, CHIYODA-KU, TOKYO 100-8310, JAPAN
Authorized representative in EU: MITSUBISHI ELECTRIC EUROPE.B.V.

HARMAN HOUSE, 1 GEROGUE STREET, UXBRIDGE,
MIDDLESEX, UB8 1QQ, U.K.