



TECHNICAL & SERVICE MANUAL

R410A

Outdoor unit
[Model names]

SUZ-KA25VA2

SUZ-KA35VA2

SUZ-KA50VA2

SUZ-KA60VA2

SUZ-KA71VA2

[Service Ref.]

SUZ-KA25VA2.TH

SUZ-KA35VA2.TH

SUZ-KA50VA2.TH

SUZ-KA60VA2.TH

SUZ-KA71VA2.TH

Revision:

- Part No. of INVERTER P.C. BOARD (P.11) has been modified.

CONTENTS

1. RoHS PARTS LIST.....	2
-------------------------	---

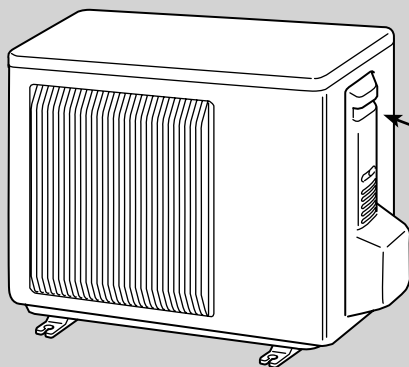

Indication of
model name

SUZ-KA25VA2.TH
SUZ-KA35VA2.TH

SERVICE MANUAL (OCH472)

NOTE:

This service manual describes technical data of the outdoor units.
RoHS compliant products have <G> mark on the spec name plate.
For servicing of RoHS compliant products, refer to the RoHS Parts List.

1

RoHS PARTS LIST

SUZ-KA25VA2.TH SUZ-KA35VA2.TH

1-1. OUTDOOR UNIT ELECTRICAL PARTS

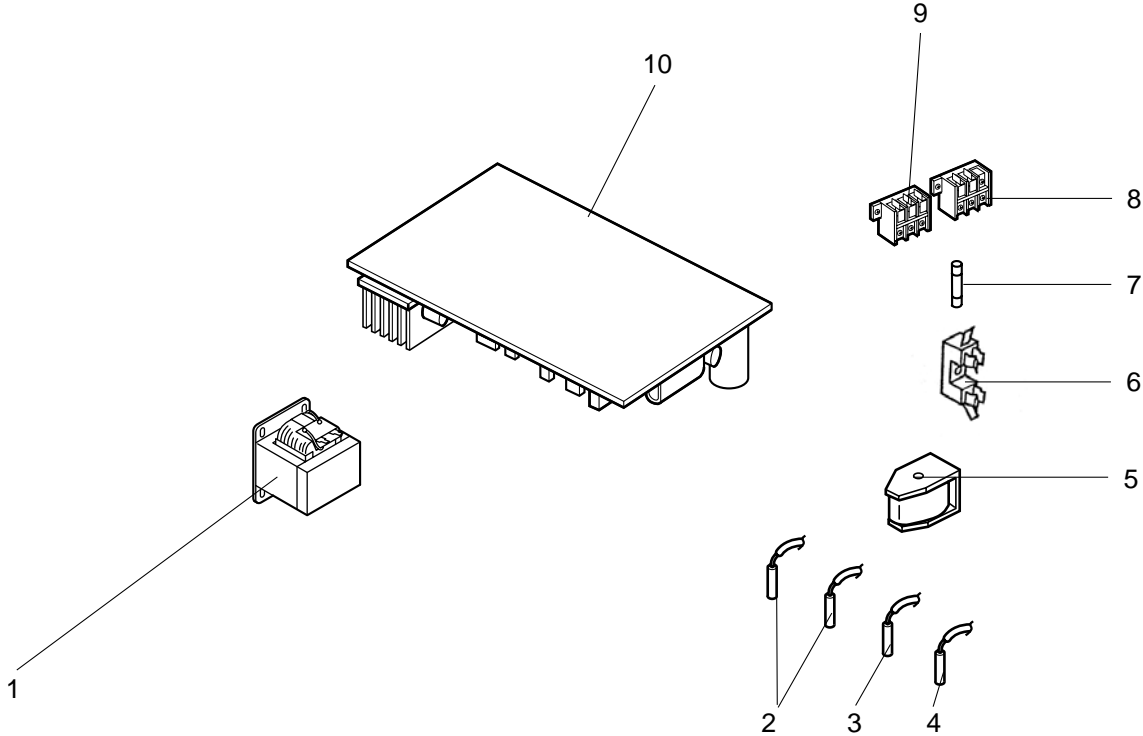

SUZ-KA25VA2.TH

SUZ-KA35VA2.TH

1-1. OUTDOOR UNIT ELECTRICAL PARTS

Part numbers that are circled are not shown in the illustration.

No.	RoHS	Part No.	Part Name	Symbol in Wiring Diagram	Q'ty/unit		Remarks
					SUZ-KA-VA2.TH		
					25	35	
1	G	E12 838 337	REACTOR	L61	1	1	
2	G	E12 C34 306	THERMISTOR SET	RT61,RT62	1	1	DEFROST, DISCHARGE
3	G	E12 927 308	AMBIENT TEMPERATURE THERMISTOR	RT65	1	1	
4	G	E12 C34 307	OUTDOOR HEAT EXCHANGER TEMPERATURE THERMISTOR	RT68	1	1	
5	G	E12 C34 490	R.V. COIL	21S4	1	1	
6	G	E12 735 241	FUSE HOLDER		1	1	
7	G	E12 735 382	FUSE	F61	1	1	T20AL250V
8	G	E12 D69 374	TERMINAL BLOCK	TB1	1	1	3P
9	G	E12 D70 374	TERMINAL BLOCK	TB2	1	1	3P
10	G	E17 612 451	INVERTER P.C. BOARD		1		Including heat sink and RT64
	G	E17 614 451	INVERTER P.C. BOARD			1	
⑪	G	E12 784 382	FUSE	F701,F801,F901	1	1	T3.15AL 250V
⑫	G	E12 661 385	VARISTOR	NR61~NR64	1	1	

SUZ-KA25VA2.TH

SUZ-KA35VA2.TH

1-2. OUTDOOR UNIT UNIT STRUCTURAL PARTS AND FUNCTIONAL PARTS

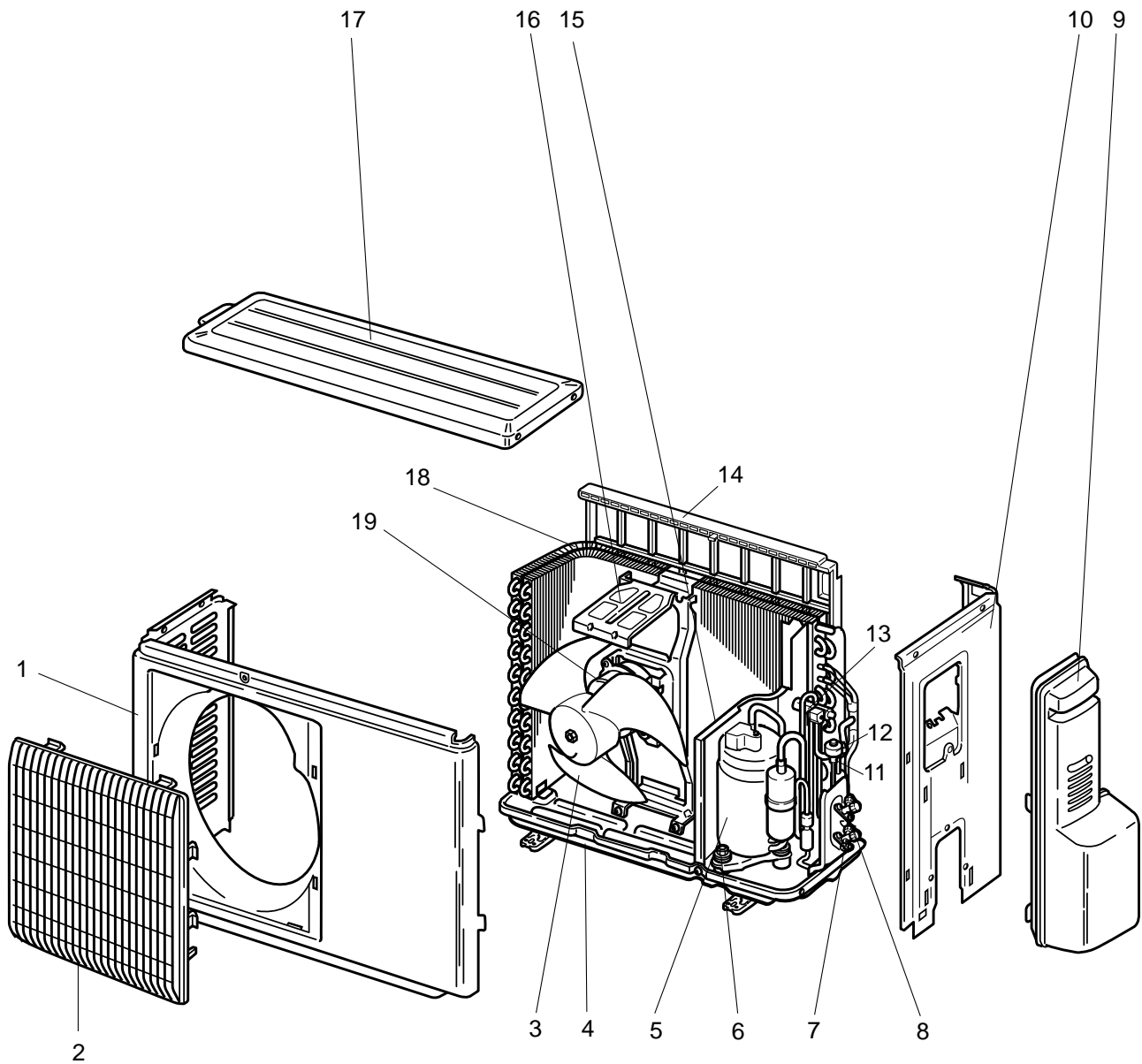

SUZ-KA25VA2.TH

SUZ-KA35VA2.TH

1-2. OUTDOOR UNIT UNIT STRUCTURAL PARTS AND FUNCTIONAL PARTS

Part numbers that are circled are not shown in the illustration.

No.	RoHS	Part No.	Part Name	Symbol in Wiring Diagram	Q'ty/unit		Remarks
					SUZ-KA-VA2.TH		
					25	35	
1	G	E12 927 232	CABINET		1	1	
2	G	E12 927 521	GRILLE		1	1	
3	G	E12 927 501	PROPELLER		1	1	
4	G	E12 D69 290	BASE		1	1	
5	G	E12 D69 900	COMPRESSOR	MC	1		KNB073FFDHC
	G	E12 D70 900	COMPRESSOR	MC		1	KNB092FFAHC
6	G	E12 065 506	COMPRESSOR RUBBER SET		3	3	3 RUBBERS/SET
7	G	E12 D69 661	STOP VALVE (GAS)		1	1	ø9.52
8	G	E12 D58 662	STOP VALVE (LIQUID)		1	1	ø6.35
9	G	E12 927 245	SERVICE PANEL		1	1	
10	G	E12 927 233	BACK PANEL		1	1	
11	G	E12 927 640	EXPANSION VALVE		1	1	
12	G	E12 927 493	EXPANSION VALVE COIL	LEV	1	1	
13	G	E12 D65 961	4-WAY VALVE		1	1	
14	G	E12 B83 523	CONDENSER NET		1		
	G	E12 929 523	CONDENSER NET			1	
15	G	E12 D69 293	SEPARATOR		1		
	G	E12 C34 293	SEPARATOR			1	
16	G	E12 927 515	MOTOR SUPPORT		1		
	G	E12 929 515	MOTOR SUPPORT			1	
17	G	E12 927 297	TOP PANEL		1	1	
18	G	E12 D69 630	OUTDOOR HEAT EXCHANGER		1		
	G	E12 D70 630	OUTDOOR HEAT EXCHANGER			1	
19	G	E12 D69 301	OUTDOOR FAN MOTOR	MF	1	1	RC0J50-□□
⑳	G	E12 927 937	CAPILLARY TUBE		1	1	ø3.0 × ø2.0 × 240
㉑	G	E12 735 936	CAPILLARY TUBE			2	ø3.0 × ø1.8 × 600

SUZ-KA50VA2.TH

1-3. OUTDOOR UNIT STRUCTURAL PARTS, ELECTRICAL PARTS AND FUNCTIONAL PARTS

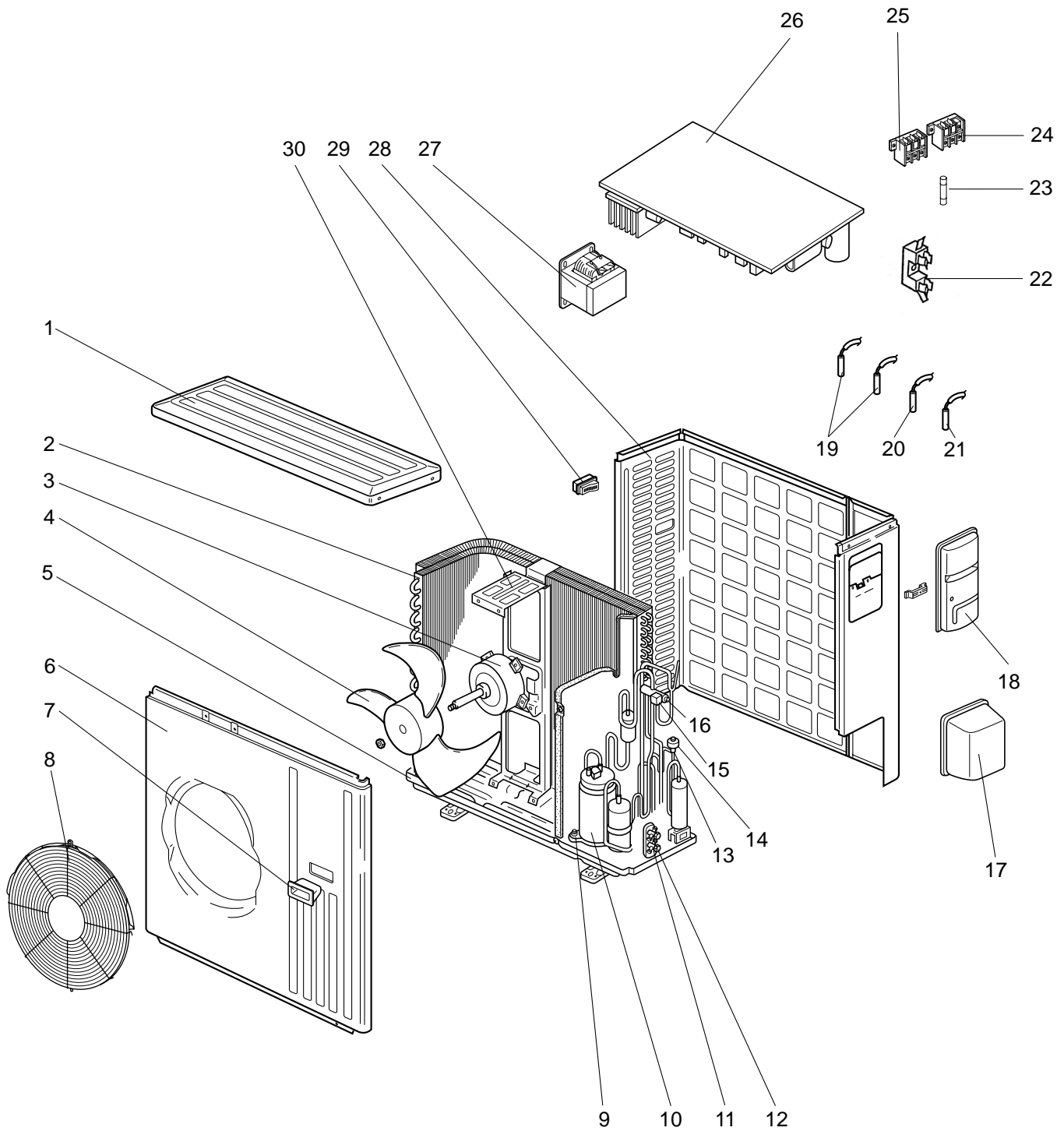

1-3. OUTDOOR UNIT STRUCTURAL PARTS, ELECTRICAL PARTS AND FUNCTIONAL PARTS

Part numbers that are circled are not shown in the illustration.

No.	RoHS	Part No.	Part Name	Symbol in Wiring Diagram	Q'ty/unit		Remarks
						SUZ-KA50VA2.TH	
1	G	E12 819 297	TOP PANEL			1	
2	G	E12 851 630	OUTDOOR HEAT EXCHANGER			1	
3	G	E12 938 301	OUTDOOR FAN MOTOR	MF		1	RC0J60-□□
4	G	E12 851 501	PROPELLER FAN			1	
5	G	E12 851 290	BASE			1	
6	G	E12 819 232	CABINET			1	
7	G	E12 819 009	HANDLE			1	
8	G	E12 D84 521	FAN GUARD			1	
9	G	E12 C34 506	COMPRESSOR RUBBER SET			3	3 RUBBERS/SET
10	G	E12 E05 900	COMPRESSOR	MC		1	SNB130FGBHT
11	G	E12 D58 661	STOP VALVE (GAS)			1	∅12.7
12	G	E12 D58 662	STOP VALVE (LIQUID)			1	∅6.35
13	G	E12 851 640	EXPANSION VALVE			1	
14	G	E12 D58 493	EXPANSION VALVE COIL	LEV		1	
15	G	E12 D58 490	R.V. COIL	21S4		1	
16	G	E12 C18 961	4-WAY VALVE			1	
17	G	E12 819 650	VALVE COVER			1	
18	G	E12 819 245	SERVICE PANEL			1	
19	G	E12 D58 306	THERMISTOR SET	RT61,RT62		1	DEFROST, DISCHARGE
20	G	E12 D58 309	AMBIENT TEMPERATURE THERMISTOR	RT65		1	
21	G	E12 C34 307	OUTDOOR HEAT EXCHANGER TEMPERATURE THERMISTOR	RT68		1	
22	G	E12 735 241	FUSE HOLDER			1	
23	G	E12 735 382	FUSE	F61		1	T20AL250V
24	G	E12 927 374	TERMINAL BLOCK	TB1		1	3 P
25	G	E12 D69 374	TERMINAL BLOCK	TB2		1	3 P
26	G	E17 616 451	INVERTER P.C. BOARD			1	Including heatsink and RT64
27	G	E12 D58 337	REACTOR	L61		1	
28	G	E12 D58 233	BACK PANEL (OUT)			1	
29	G	E12 817 009	HANDLE			1	
30	G	E12 851 515	MOTOR SUPPORT			1	
31	G	E12 851 936	CAPILLARY TUBE (TAPER PIPE)			1	∅3.6 × ∅2.4 × 50
32	G	E12 784 382	FUSE	F701,801,901		1	T3.15AL250V
33	G	E12 661 385	VARISTOR	NR61-64		1	

SUZ-KA60VA2.TH

1-4. OUTDOOR UNIT STRUCTURAL PARTS, ELECTRICAL PARTS AND FUNCTIONAL PARTS

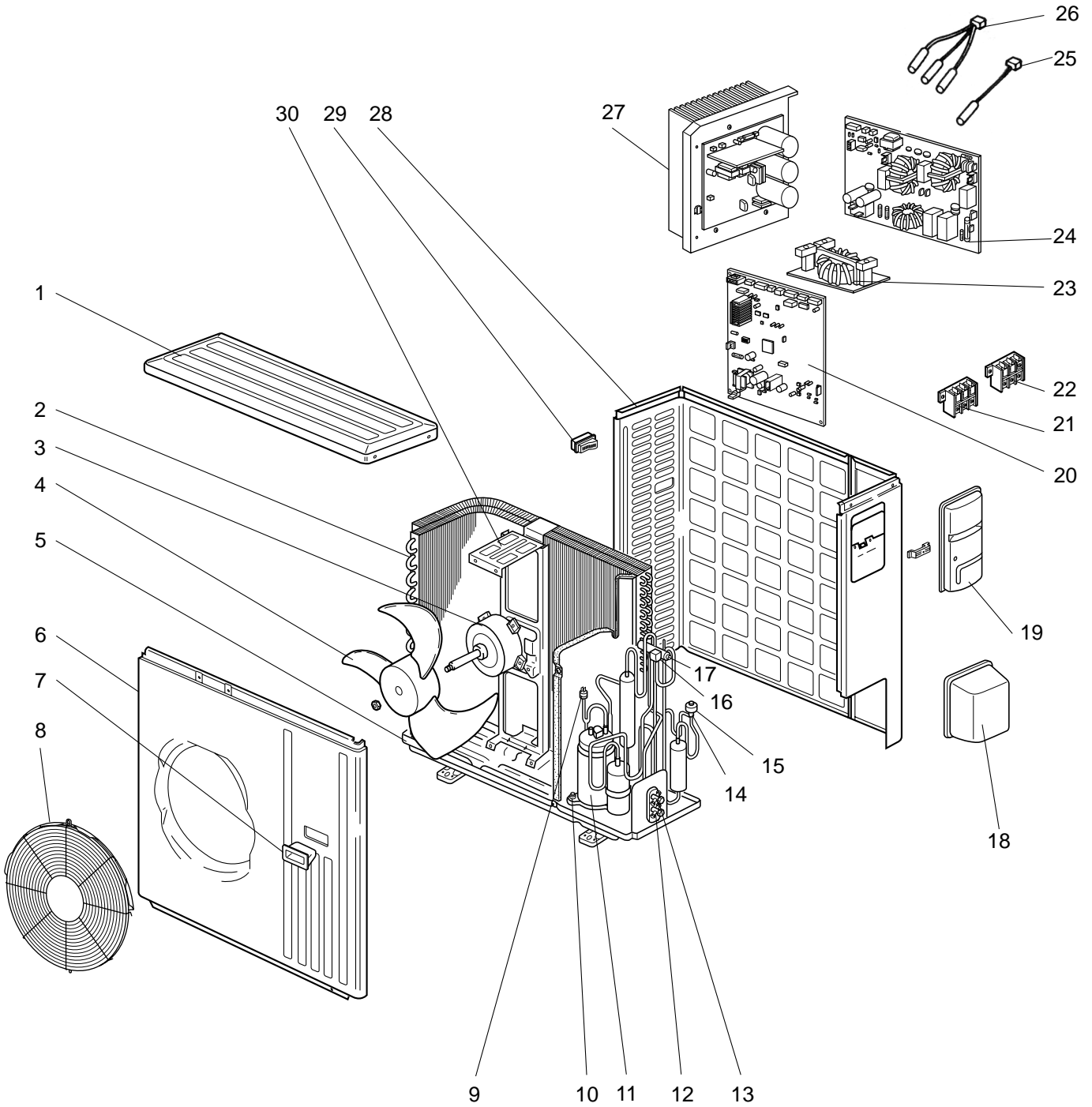

1-4. OUTDOOR UNIT STRUCTURAL PARTS, ELECTRICAL PARTS AND FUNCTIONAL PARTS

Part numbers that are circled are not shown in the illustration.

No.	RCHS	Part No.	Part Name	Symbol in Wiring Diagram	Q'ty/unit		Remarks
						SUZ-KA60VA2.TH	
1	G	E12 819 297	TOP PANEL			1	
2	G	E12 851 630	OUTDOOR HEAT EXCHANGER			1	
3	G	E12 938 301	OUTDOOR FAN MOTOR	MF		1	RC0J60-□□
4	G	E12 851 501	PROPELLER FAN			1	
5	G	E12 851 290	BASE			1	
6	G	E12 819 232	CABINET			1	
7	G	E12 819 009	HANDLE			1	
8	G	E12 D84 521	FAN GUARD			1	
9	G	E12 853 646	HIGH PRESSURE SWITCH	HPS		1	
10	G	E12 C34 506	COMPRESSOR RUBBER SET			3	3 RUBBERS/SET
11	G	E12 E05 900	COMPRESSOR	MC		1	SNB130FGBHT
12	G	E12 819 661	STOP VALVE (GAS)			1	∅15.88
13	G	E12 821 662	STOP VALVE (LIQUID)			1	∅6.35
14	G	E12 851 640	EXPANSION VALVE			1	
15	G	E12 851 493	EXPANSION VALVE COIL	LEV		1	
16	G	E12 D02 490	R.V. COIL	21S4		1	
17	G	E12 C18 961	4-WAY VALVE			1	
18	G	E12 819 650	VALVE COVER			1	
19	G	E12 819 245	SERVICE PANEL			1	
20	G	E17 618 450	OUTDOOR ELECTRONIC CONTROL P.C. BOARD			1	
21	G	E12 D69 374	TERMINAL BLOCK	TB2		1	3P
22	G	E12 935 374	TERMINAL BLOCK	TB1		1	3P
23	G	E12 851 337	REACTOR	L		1	
24	G	E12 935 444	NOISE FILTER P.C. BOARD			1	
25	G	E12 935 309	AMBIENT TEMPERATURE THERMISTOR	RT65		1	
26	G	E12 851 308	THERMISTOR SET	RT61,RT62,RT68		1	DEFROST, DISCHARGE OUTDOOR HEAT EXCHANGER
27	G	E12 B79 440	POWER BOARD			1	Including heatsink and RT64
28	G	E12 D58 233	BACK PANEL (OUT)			1	
29	G	E12 817 009	HANDLE			1	
30	G	E12 851 515	MOTOR SUPPORT			1	
③1	G	E12 784 382	FUSE	F801		1	T3.15AL 250V
③2	G	E12 B79 382	FUSE	F911		1	T1AL 250V
③3	G	E12 977 385	FUSE & VARISTOR	F64,NR64		1	
③4	G	E12 851 936	CAPILLARY TUBE (TAPER PIPE)			1	∅3.6 × ∅2.4 × 50

SUZ-KA71VA2.TH

1-5. OUTDOOR UNIT STRUCTURAL PARTS, ELECTRICAL PARTS AND FUNCTIONAL PARTS

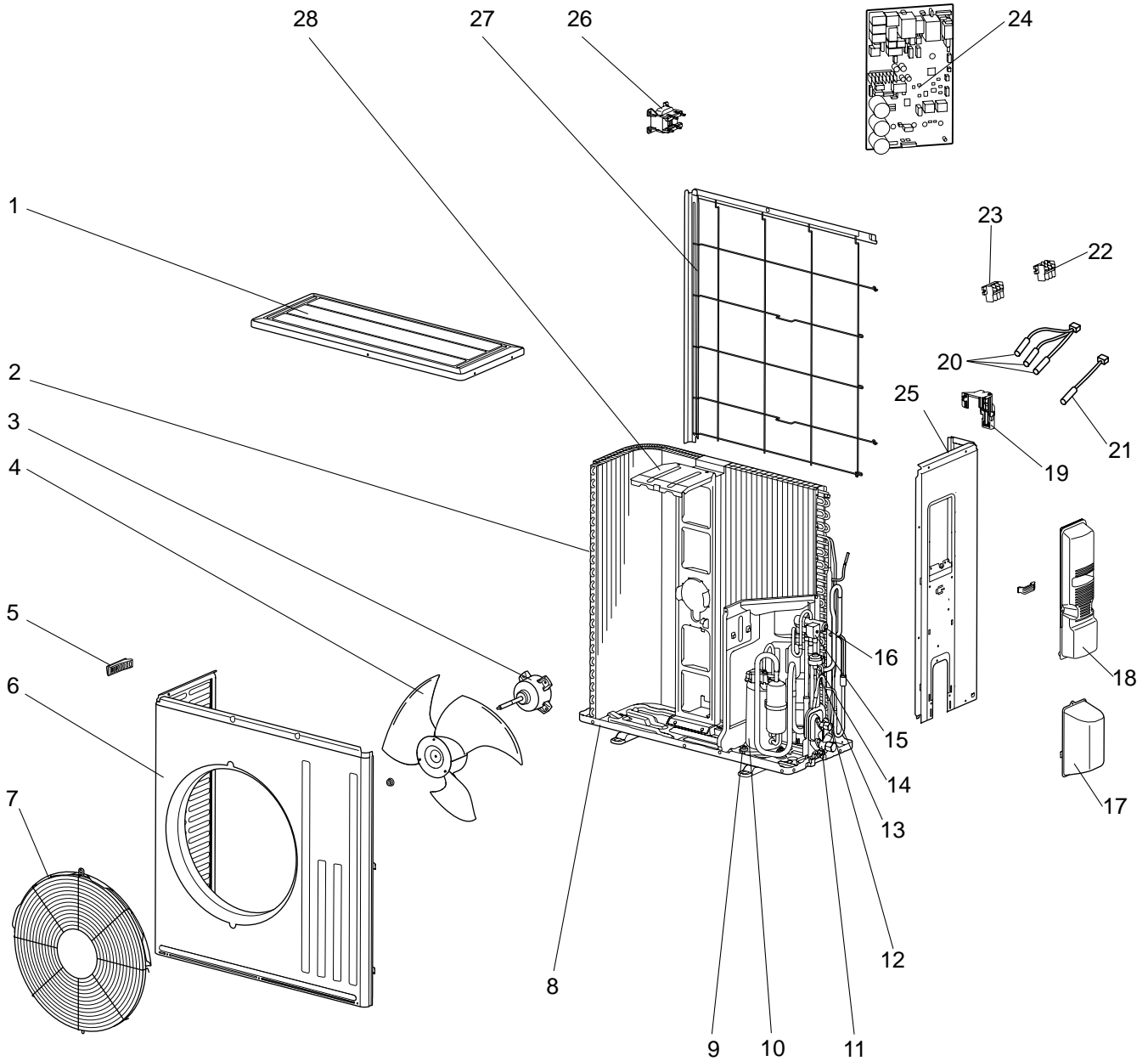

1-5. OUTDOOR UNIT STRUCTURAL PARTS, ELECTRICAL PARTS AND FUNCTIONAL PARTS

Part numbers that are circled are not shown in the illustration.

No.	RoHS	Part No.	Part Name	Symbol in Wiring Diagram	Q'ty/unit		Remarks
						SUZ-KA71VA2.TH	
1	G	E12 F28 297	TOP PANEL			1	
2	G	E12 F29 630	OUTDOOR HEAT EXCHANGER			1	
3	G	E12 F28 301	OUTDOOR FAN MOTOR	MF		1	RC0J60-□□
4	G	E12 F28 501	PROPELLER			1	
5	G	E12 817 009	HANDLE			1	
6	G	E12 F28 232	CABINET			1	
7	G	E12 F73 521	FAN GUARD			1	
8	G	E12 F28 290	BASE			1	
9	G	E12 C34 506	COMPRESSOR RUBBER SET			3	3 RUBBERS/SET
10	G	E12 F29 900	COMPRESSOR	MC		1	SNB172FEKMT
11	G	E12 F28 661	STOP VALVE (GAS)			1	∅15.88
12	G	E12 F29 662	STOP VALVE (LIQUID)			1	∅9.52
13	G	E12 853 640	EXPANSION VALVE			1	
14	G	E12 F28 493	EXPANSION VALVE COIL	LEV		1	
15	G	E12 F28 490	R.V. COIL	21S4		1	
16	G	E12 C18 961	4-WAY VALVE			1	
17	G	E12 F28 650	VALVE COVER			1	
18	G	E12 F28 245	SERVICE PANEL			1	
19	G	E12 F28 079	THERMO HOLDER			1	
20	G	E12 F28 308	THERMISTOR SET	RT61,RT62, RT68		1	DEFROST, DISCHARGE, OUTDOOR HEAT EXCHANGER TEMPERATURE
21	G	E12 F28 309	AMBIENT TEMPERATURE THERMISTOR	RT65		1	
22	G	E12 F29 374	TERMINAL BLOCK	TB1		1	3 P
23	G	E12 F28 374	TERMINAL BLOCK	TB2		1	3 P
24	G	E17 620 451	INVERTER P.C. BOARD			1	Including heat sink and RT64
25	G	E12 F28 233	BACK PANEL (OUT)			1	
26	G	E12 F28 337	REACTOR	L		1	
27	G	E12 F28 523	CONDENSER NET			1	
28	G	E12 F28 515	MOTOR SUPPORT			1	
29	G	E12 527 936	CAPILLARY TUBE			1	∅4.0 × ∅2.4 × 100
30	G	E12 C67 382	FUSE	F601,880,901		1	T3.15A L250V
31	G	E12 F28 382	FUSE	F62		1	T2.0A L250V
32	G	E12 A45 385	VARISTOR	NR601		1	
33	G	E12 F28 527	HEATER ASSEMBLY			1	

SUZ-KA25VA2.TH SUZ-KA35VA2.TH
1-6. DRAIN SOCKET

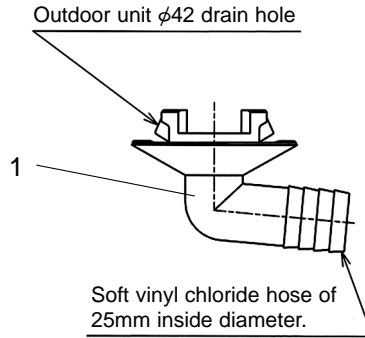

No.	RoHS	Part No.	Part Name	Symbol in Wiring Diagram	Q'ty/unit		Remarks
					SUZ-KA-VA2.TH		
					25	35	
1	G	E12 838 704	DRAIN SOCKET		1	1	

SUZ-KA50VA2.TH SUZ-KA60VA2.TH SUZ-KA71VA2.TH
1-7. ACCESSORY

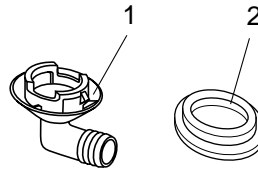

No.	RoHS	Part No.	Part Name	Symbol in Wiring Diagram	Q'ty/unit			Remarks
					SUZ-KA-VA2.TH			
					50	60	71	
1	G	E12 817 704	DRAIN SOCKET		1	1		
	G	E12 F28 704	DRAIN SOCKET			1		
2	G	E12 444 705	DRAIN CAP		2	2	ø33, 2PCS/SET	

MITSUBISHI ELECTRIC CORPORATION

HEAD OFFICE: TOKYO BLDG., 2-7-3, MARUNOUCHI, CHIYODA-KU, TOKYO100-8310, JAPAN