

Air-Conditioners

PLA-RP·BA Series

PLA-ZRP·BA Series

INSTALLATION MANUAL

For safe and correct use, read this manual and the outdoor unit installation manual thoroughly before installing the air-conditioner unit.

FOR INSTALLER

INSTALLATIONSHANDBUCH

Aus Sicherheitsgründen und zur richtigen Anwendung vor Installation der Klimaanlage die vorliegende Bedienungsanleitung und das Installationshandbuch gründlich durchlesen.

FÜR INSTALLATEURE

MANUEL D'INSTALLATION

Avant d'installer le climatiseur, lire attentivement ce manuel, ainsi que le manuel d'installation de l'appareil extérieur pour une utilisation sûre et correcte.

POUR L'INSTALLATEUR

INSTALLATIEHANDLEIDING

Lees deze handleiding en de installatiehandleiding van het buitenapparaat zorgvuldig door voordat u met het installeren van de airconditioner begint.

VOOR DE INSTALLATEUR

MANUAL DE INSTALACIÓN

Para un uso seguro y correcto, lea detalladamente este manual de instalación antes de montar la unidad de aire acondicionado.

PARA EL INSTALADOR

MANUALE DI INSTALLAZIONE

Per un uso sicuro e corretto, prima di installare il condizionatore d'aria leggere attentamente il presente manuale ed il manuale d'installazione dell'unità esterna.

PER L'INSTALLATORE

ΕΓΧΕΙΡΙΔΙΟ ΟΔΗΓΙΩΝ ΕΓΚΑΤΑΣΤΑΣΗΣ

Για σωστή και ασφαλή χρήση, διαβάστε προσεκτικά αυτό το εγχειρίδιο, καθώς και το εγχειρίδιο εγκατάστασης της εξωτερικής μονάδας, πριν από την εγκατάσταση της μονάδας κλιματιστικού.

ΓΙΑ ΑΥΤΟΝ ΠΟΥ ΚΑΝΕΙ ΤΗΝ ΕΓΚΑΤΑΣΤΑΣΗ

MANUAL DE INSTALAÇÃO

Para uma utilização segura e correcta, leia atentamente este manual e o manual de instalação da unidade exterior antes de instalar o aparelho de ar condicionado.

PARA O INSTALADOR

INSTALLATIONSMANUAL

Læs af sikkerhedshensyn denne manual samt manualen til installation af udendørsenheden grundigt, før du installerer klimaanlægget.

TIL INSTALLATØREN

INSTALLATIONSMANUAL

Läs bruksanvisningen och utomhusenhetens installationshandbok noga innan luftkonditioneringen installeras så att den används på ett säkert och korrekt sätt.

FÖR INSTALLATÖREN

MONTAJ ELKİTABI

Emniyetli ve doğru kullanım için, klima cihazını monte etmeden önce bu kılavuzu ve dış ünite montaj kılavuzunu tamamiyla okuyun.

MONTÖR İÇİN

РУКОВОДСТВО ПО УСТАНОВКЕ

Для обеспечения безопасной и надлежащей эксплуатации внимательно прочтите данное руководство и руководство по установке наружного прибора перед установкой кондиционера.

ДЛЯ УСТАНОВИТЕЛЯ**English****Deutsch****Français****Nederlands****Español****Italiano****Ελληνικά****Português****Dansk****Svenska****Türkçe****Русский**

Contents

1. Safety precautions.....	2	6. Electrical work	7
2. Installation location.....	3	7. Test run.....	14
3. Installing the indoor unit	3	8. System control	17
4. Installing the refrigerant piping	5	9. Installing the grille.....	17
5. Drainage piping work.....	6	10. Easy maintenance function	19

Note:
The phrase “Wired remote controller” in this installation manual refers only to the PAR-21MAA.
If you need any information for the other remote controller, please refer to either the installation manual or initial setting manual which are included in these boxes.

1. Safety precautions

- ▶ Before installing the unit, make sure you read all the “Safety precautions”.
- ▶ Please report to your supply authority or obtain their consent before connecting this equipment to the power supply system.

⚠ Warning:
Describes precautions that must be observed to prevent danger of injury or death to the user.

⚠ Caution:
Describes precautions that must be observed to prevent damage to the unit.

- ⚠ Warning:**
- Ask a dealer or an authorized technician to install the unit.
 - The user should never attempt to repair the unit or transfer it to another location.
 - For installation work, follow the instructions in the Installation Manual and use tools and pipe components specifically made for use with refrigerant specified in the outdoor unit installation manual.
 - The unit must be installed according to the instructions in order to minimize the risk of damage from earthquakes, typhoons, or strong winds. An incorrectly installed unit may fall down and cause damage or injuries.
 - The unit must be securely installed on a structure that can sustain its weight.
 - If the air conditioner is installed in a small room, measures must be taken to prevent the refrigerant concentration in the room from exceeding the safety limit in the event of refrigerant leakage. Should the refrigerant leak and cause the concentration limit to be exceeded, hazards due to lack of oxygen in the room may result.
 - Ventilate the room if refrigerant leaks during operation. If refrigerant comes into contact with a flame, poisonous gases will be released.
 - All electric work must be performed by a qualified technician according to local regulations and the instructions given in this manual.
 - Use only specified cables for wiring. The wiring connections must be made securely with no tension applied on the terminal connections. Also, never splice the cables for wiring (unless otherwise indicated in this document). Failure to observe these instructions may result in overheating or a fire.

After installation work has been completed, explain the “Safety Precautions,” use, and maintenance of the unit to the customer according to the information in the Operation Manual and perform the test run to ensure normal operation. Both the Installation Manual and Operation Manual must be given to the user for keeping. These manuals must be passed on to subsequent users.

⚡ : Indicates a part which must be grounded.

⚠ Warning:
Carefully read the labels affixed to the main unit.

- The appliance shall be installed in accordance with national wiring regulations.
- The terminal block cover panel of the unit must be firmly attached.
- If the supply cord is damaged, it must be replaced by the manufacturer, its service agent or similarly qualified persons in order to avoid a hazard.
- Use only accessories authorized by Mitsubishi Electric and ask a dealer or an authorized technician to install them.
- The user should never attempt to repair the unit or transfer it to another location.
- After installation has been completed, check for refrigerant leaks. If refrigerant leaks into the room and comes into contact with the flame of a heater or portable cooking range, poisonous gases will be released.
- When installing or relocating, or servicing the air conditioner, use only the specified refrigerant (R410A) to charge the refrigerant lines. Do not mix it with any other refrigerant and do not allow air to remain in the lines. If air is mixed with the refrigerant, then it can be the cause of abnormal high pressure in the refrigerant line, and may result in an explosion and other hazards. The use of any refrigerant other than that specified for the system will cause mechanical failure or system malfunction or unit breakdown. In the worst case, this could lead to a serious impediment to securing product safety.

1.1. Before installation (Environment)

- ⚠ Caution:**
- Do not use the unit in an unusual environment. If the air conditioner is installed in areas exposed to steam, volatile oil (including machine oil), or sulfuric gas, areas exposed to high salt content such as the seaside, the performance can be significantly reduced and the internal parts can be damaged.
 - Do not install the unit where combustible gases may leak, be produced, flow, or accumulate. If combustible gas accumulates around the unit, fire or explosion may result.
 - Do not keep food, plants, caged pets, artwork, or precision instruments in the direct airflow of the indoor unit or too close to the unit, as these items can be damaged by temperature changes or dripping water.

- When the room humidity exceeds 80% or when the drainpipe is clogged, water may drip from the indoor unit. Do not install the indoor unit where such dripping can cause damage.
- When installing the unit in a hospital or communications office, be prepared for noise and electronic interference. Inverters, home appliances, high-frequency medical equipment, and radio communications equipment can cause the air conditioner to malfunction or breakdown. The air conditioner may also affect medical equipment, disturbing medical care, and communications equipment, harming the screen display quality.

1.2. Before installation or relocation

- ⚠ Caution:**
- Be extremely careful when transporting the units. Two or more persons are needed to handle the unit, as it weighs 20 kg or more. Do not grasp the packaging bands. Wear protective gloves as you can injure your hands on the fins or other parts.
 - Be sure to safely dispose of the packaging materials. Packaging materials, such as nails and other metal or wooden parts may cause stabs or other injuries.

- Thermal insulation of the refrigerant pipe is necessary to prevent condensation. If the refrigerant pipe is not properly insulated, condensation will be formed.
- Place thermal insulation on the pipes to prevent condensation. If the drainpipe is installed incorrectly, water leakage and damage to the ceiling, floor, furniture, or other possessions may result.
- Do not clean the air conditioner unit with water. Electric shock may result.
- Tighten all flare nuts to specification using a torque wrench. If tightened too much, the flare nut can break after an extended period.

1.3. Before electric work

- ⚠ Caution:**
- Be sure to install circuit breakers. If not installed, electric shock may result.
 - For the power lines, use standard cables of sufficient capacity. Otherwise, a short circuit, overheating, or fire may result.
 - When installing the power lines, do not apply tension to the cables.

- Be sure to ground the unit. If the unit is not properly grounded, electric shock may result.
- Use circuit breakers (ground fault interrupter, isolating switch (+B fuse), and molded case circuit breaker) with the specified capacity. If the circuit breaker capacity is larger than the specified capacity, breakdown or fire may result.

1.4. Before starting the test run

- ⚠ Caution:**
- Turn on the main power switch more than 12 hours before starting operation. Starting operation just after turning on the power switch can severely damage the internal parts.
 - Before starting operation, check that all panels, guards and other protective parts are correctly installed. Rotating, hot, or high voltage parts can cause injuries.

- Do not operate the air conditioner without the air filter set in place. If the air filter is not installed, dust may accumulate and breakdown may result.
- Do not touch any switch with wet hands. Electric shock may result.
- Do not touch the refrigerant pipes with bare hands during operation.
- After stopping operation, be sure to wait at least five minutes before turning off the main power switch. Otherwise, water leakage or breakdown may result.

2. Installation location

Refer to the outdoor unit installation manual.

3. Installing the indoor unit

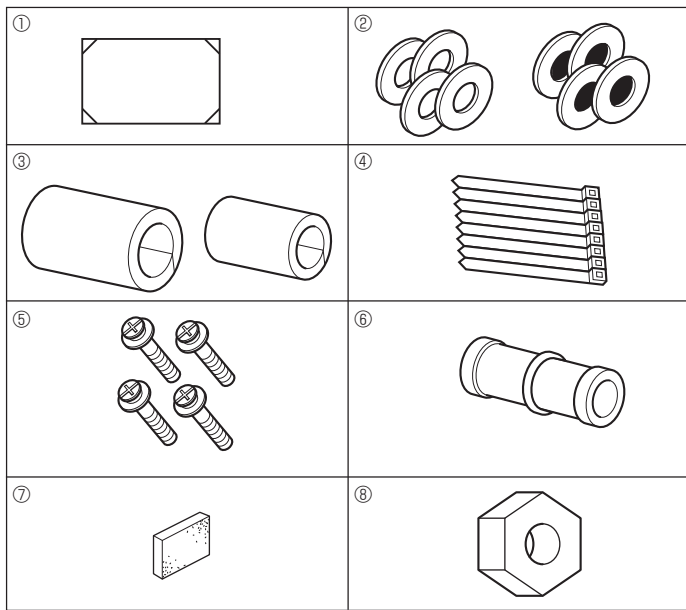

Fig. 3-1

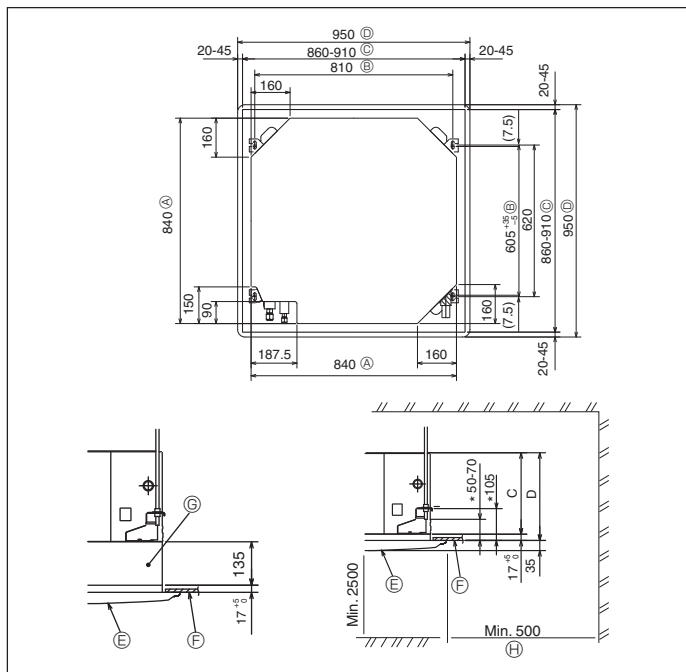

Fig. 3-2

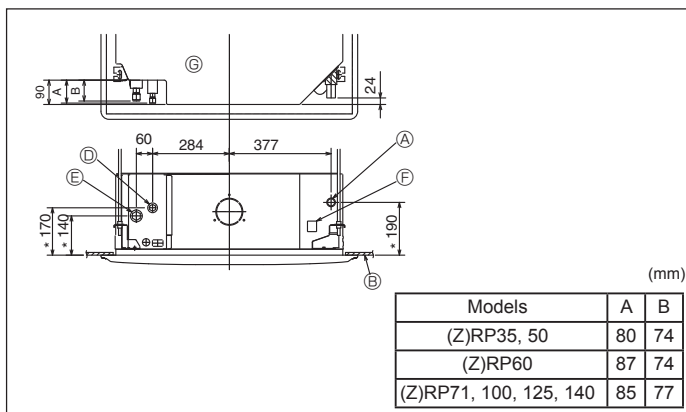

Fig. 3-3

3.1. Check the indoor unit accessories (Fig. 3-1)

The indoor unit should be supplied with the following accessories.

Accessory name	Q'ty
① Installation template	1
② Washers (with insulation)	4
② Washers (without insulation)	4
③ Pipe cover (for refrigerant piping joint)	
Small diameter	1
Large diameter	1
④ Band	8
⑤ Screw with washer (M5 × 25) for mounting grille	4
⑥ Drain socket	1
⑦ Insulation	1
⑧ Flare nut 1/4F(P60)	1

3.2. Ceiling openings and suspension bolt installation locations (Fig. 3-2)

⚠ Caution:

Install the indoor unit at least 2.5m above floor or grade level.

For appliances not accessible to the general public.

- Using the installation template (top of the package) and the gauge (supplied as an accessory with the grille), make an opening in the ceiling so that the main unit can be installed as shown in the diagram. (The method for using the template and the gauge is shown.)
 - Before using, check the dimensions of template and gauge, because they change due to fluctuations of temperature and humidity.
 - The dimensions of ceiling opening can be regulated within the range shown in Fig.3-2; so center the main unit against the opening of ceiling, ensuring that the respective opposite sides on all sides of the clearance between them becomes identical.
- Use M10 (3/8") suspension bolts.
 - Suspension bolts are to be procured at the field.
- Install securely, ensuring that there is no clearance between the ceiling panel & grille, and between the main unit & grille.
 - (A) Outer side of main unit (E) Grille
 - (B) Bolt pitch (F) Ceiling
 - (C) Ceiling opening (G) Multi function casement (option)
 - (D) Outer side of Grille (H) Entire periphery

*Note that the space between ceiling panel of the unit and ceiling slab, etc. must be 10 to 15 mm.

* When the optional multi-functional casement is installed, add 135 mm to the dimensions marked on the figure.

(mm)

Models	C	D
PLA-RP35/50/60/71BA(2) PLA-ZRP35/50/60BA	241	258
PLA-RP100/125/140BA(2) PLA-RP100BA3 PLA-ZRP71/100/125/140BA	281	298

3.3. Refrigerant and drainage piping locations of indoor unit

The figure marked with * in the drawing represent the dimensions of the main unit excluding those of the optional multi function casement. (Fig. 3-3)

- (A) Drain pipe
- (B) Ceiling
- (C) Grille
- (D) Refrigerant pipe (liquid)
- (E) Refrigerant pipe (gas)
- (F) Water supply inlet
- (G) Main unit

* When the optional multi-functional casement is installed, add 135 mm to the dimensions marked on the figure.

3. Installing the indoor unit

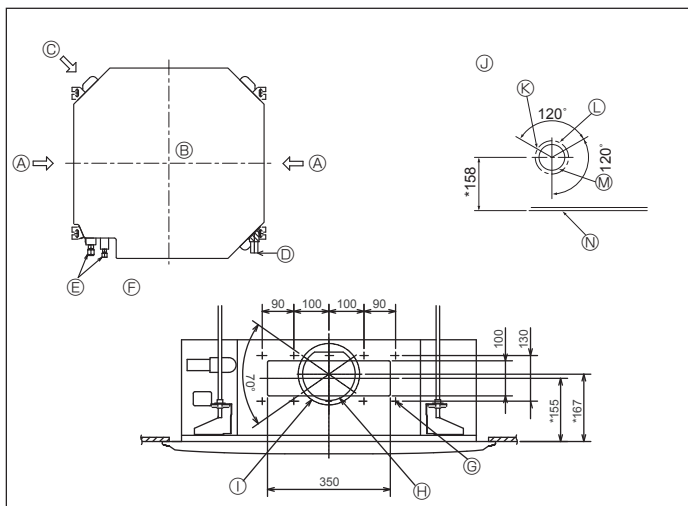

Fig. 3-4

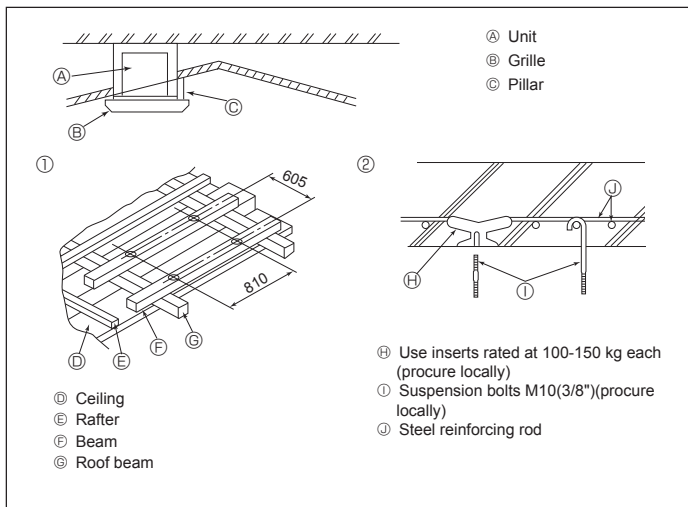

Fig. 3-5

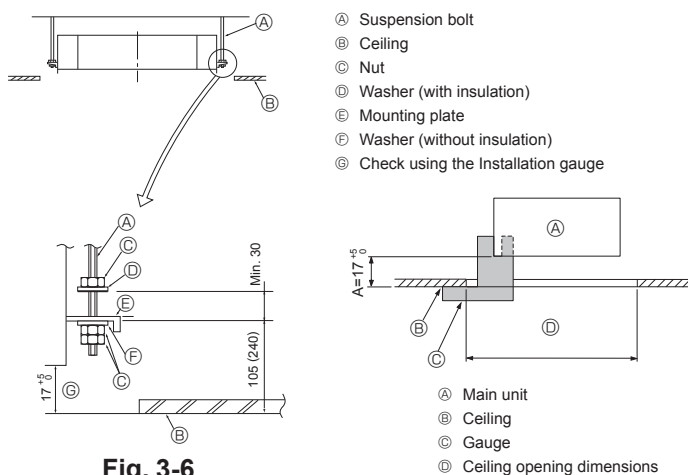

Fig. 3-6

Fig. 3-7

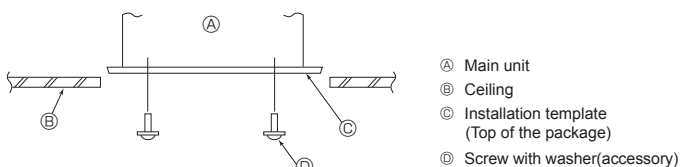

Fig. 3-8

3.4. Branch duct hole and fresh air intake hole (Fig. 3-4)

At the time of installation, use the duct holes (cut out) located at the positions shown in Fig.3-4, as and when required.

- A fresh air intake hole for the optional multi function casement can also be made.

Note:

The figure marked with * in the drawing represent the dimensions of the main unit excluding those of the optional multi function casement.

When installing the optional multi function casement, add 135 mm to the dimensions marked on the figure.

When installing the branch ducts, be sure to insulate adequately. Otherwise condensation and dripping may occur.

- | | |
|--|---------------------------------|
| Ⓐ Branch duct hole | Ⓜ 14- ϕ 2.8 burring hole |
| Ⓑ Indoor unit | Ⓨ ϕ 150 cut out hole |
| Ⓒ Fresh air intake hole | Ⓩ ϕ 175 burring hole pitch |
| Ⓓ Drain pipe | ⓐ Fresh air intake hole diagram |
| Ⓔ Refrigerant pipe | Ⓥ 3- ϕ 2.8 burring hole |
| Ⓕ Branch duct hole diagram (view from either side) | ⓗ ϕ 125 burring hole pitch |
| | Ⓣ ϕ 100 cut out hole |
| | Ⓤ Ceiling |

3.5. Suspension structure (Give site of suspension strong structure) (Fig. 3-5)

• The ceiling work differs according to the construction of the building. Building constructors and interior decorators should be consulted for details.

- (1) Extent of ceiling removal: The ceiling must be kept completely horizontal and the ceiling foundation (framework: wooden slats and slat holders) must be reinforced in order to protect the ceiling from vibration.
- (2) Cut and remove the ceiling foundation.
- (3) Reinforce the ends of the ceiling foundation where it has been cut and add ceiling foundation for securing the ends of the ceiling board.
- (4) When installing the indoor unit on a slanted ceiling, attach a pillar between the ceiling and the grille and set so that the unit is installed horizontally.

- ① Wooden structures
 - Use tie beams (single storied houses) or second floor beams (2 story houses) as reinforcing members.
 - Wooden beams for suspending air conditioners must be sturdy and their sides must be at least 6 cm long if the beams are separated by not more than 90 cm and their sides must be at least 9 cm long if the beams are separated by as much as 180 cm. The size of the suspension bolts should be ϕ 10 (3/8"). (The bolts do not come with the unit.)

- ② Ferro-concrete structures
 - Secure the suspension bolts using the method shown, or use steel or wooden hangers, etc. to install the suspension bolts.

3.6. Unit suspension procedures (Fig. 3-6)

Suspend the main unit as shown in the diagram.

Figures given in parentheses represent the dimensions in case of installing optional multi function casement.

1. In advance, set the parts onto the suspension bolts in the order of the washers (with insulation), washers (without insulation) and nuts (double).
 - Fit the washer with cushion so that the insulation faces downward.
 - In case of using upper washers to suspend the main unit, the lower washers (with insulation) and nuts (double) are to be set later.
2. Lift the unit to the proper height of the suspension bolts to insert the mounting plate between washers and then fasten it securely.
3. When the main unit cannot be aligned against the mounting hole on the ceiling, it is adjustable owing to a slot provided on the mounting plate.
 - Make sure that A is performed within 17-22 mm. Damage could result by failing to adhere to this range. (Fig. 3-7)

⚠ Caution:

Use the top half of the box as a protective cover to prevent dust or debris from getting inside the unit prior to installation of the decorative cover or when applying ceiling materials.

3.7. Confirming the position of main unit and tightening the suspension bolts (Fig. 3-8)

- Using the gauge attached to the grille, ensure that the bottom of the main unit is properly aligned with the opening of the ceiling. Be sure to confirm this, otherwise condensation may form and drip due to air leakage, etc.
- Confirm that the main unit is horizontally levelled, using a level or a vinyl tube filled with water.
- After checking the position of the main unit, tighten the nuts of the suspension bolts securely to fasten the main unit.
- The installation template (top of the package) can be used as a protective sheet to prevent dust from entering the main unit when the grilles are left unattached for a while or when the ceiling materials are to be lined after installation of the unit is finished.

* As for the details of fitting, refer to the instructions given on the Installation template.

4. Installing the refrigerant piping

4.1. Precautions

For devices that use R410A refrigerant

- Use ester oil, ether oil or alkylbenzene oil (small amount) as the refrigeration oil applied to the flared sections.
- Use C1220 copper phosphorus for copper and copper alloy seamless pipes, to connect the refrigerant pipes. Use refrigerant pipes with the thicknesses specified in the table below. Make sure the insides of the pipes are clean and do not contain any harmful contaminants such as sulfuric compounds, oxidants, debris, or dust.

⚠ Warning:

When installing or relocating, or servicing the air conditioner, use only the specified refrigerant (R410A) to charge the refrigerant lines. Do not mix it with any other refrigerant and do not allow air to remain in the lines. If air is mixed with the refrigerant, then it can be the cause of abnormal high pressure in the refrigerant line, and may result in an explosion and other hazards.

The use of any refrigerant other than that specified for the system will cause mechanical failure or system malfunction or unit breakdown. In the worst case, this could lead to a serious impediment to securing product safety.

	(Z)RP35, 50	(Z)RP60-140
Liquid pipe	φ 6.35 thickness 0.8 mm	φ 9.52 thickness 0.8 mm
Gas pipe	φ 12.7 thickness 0.8 mm	φ 15.88 thickness 1.0 mm

- Do not use pipes thinner than those specified above.

4.2. Connecting pipes (Fig. 4-1)

- When commercially available copper pipes are used, wrap liquid and gas pipes with commercially available insulation materials (heat-resistant to 100 °C or more, thickness of 12 mm or more).
- The indoor parts of the drain pipe should be wrapped with polyethylene foam insulation materials (specific gravity of 0.03, thickness of 9 mm or more).
- Apply thin layer of refrigerant oil to pipe and joint seating surface before tightening flare nut.
- Use 2 wrenches to tighten piping connections.
- Use refrigerant piping insulation provided to insulate indoor unit connections. Insulate carefully.

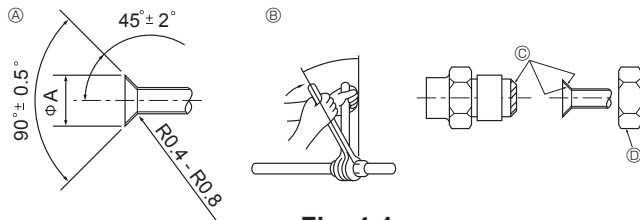

Fig. 4-1

(A) Flare cutting dimensions

Copper pipe O.D. (mm)	Flare dimensions φA dimensions (mm)
φ6.35	8.7 - 9.1
φ9.52	12.8 - 13.2
φ12.7	16.2 - 16.6
φ15.88	19.3 - 19.7
φ19.05	23.6 - 24.0

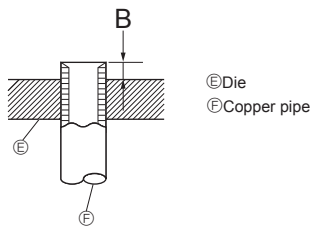

Fig. 4-2

Copper pipe O.D. (mm)	B (mm)
	Flare tool for R410A Clutch type
φ6.35 (1/4")	0 - 0.5
φ9.52 (3/8")	0 - 0.5
φ12.7 (1/2")	0 - 0.5
φ15.88 (5/8")	0 - 0.5
φ19.05 (3/4")	0 - 0.5

(B) Flare nut tightening torque

Copper pipe O.D. (mm)	Flare nut O.D. (mm)	Tightening torque (N·m)
φ6.35	17	14-18
φ6.35	22	34-42
φ9.52	22	34-42
φ12.7	26	49-61
φ12.7	29	68-82
φ15.88	29	68-82
φ15.88	36	100-120
φ19.05	36	100-120

- (C) Apply refrigerating machine oil over the entire flare seat surface.
- (D) Use correct flare nuts meeting the pipe size of the outdoor unit.

Available pipe size

	(Z)RP35, 50	(Z)RP60	(Z)RP71-140
Liquid side	φ6.35 O	φ6.35	—
Gas side	φ12.7 O	φ9.52 O	φ9.52 O
		φ15.88 O	φ15.88 O

O : Factory flare nut attachment to the heat exchanger.

⚠ Warning:

When installing the unit, securely connect the refrigerant pipes before starting the compressor.

4. Installing the refrigerant piping

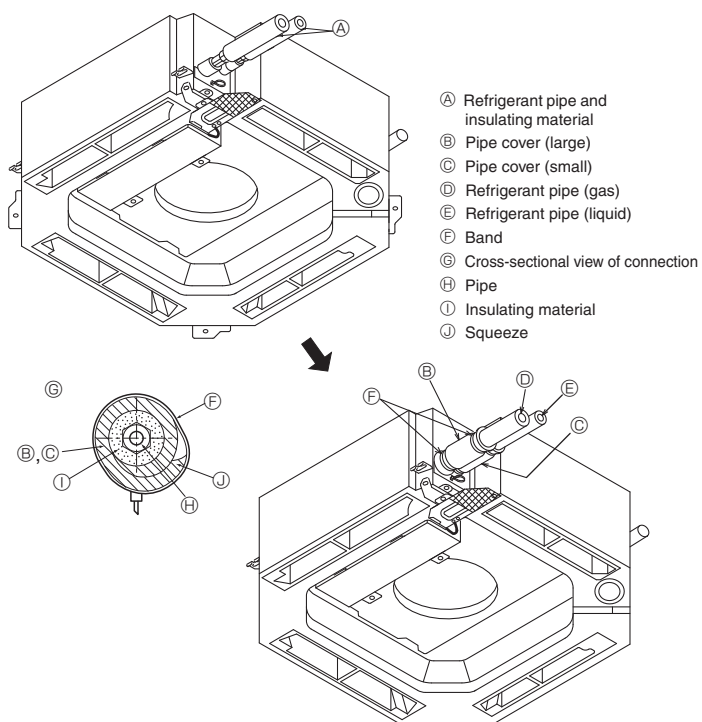

Fig. 4-3

5. Drainage piping work

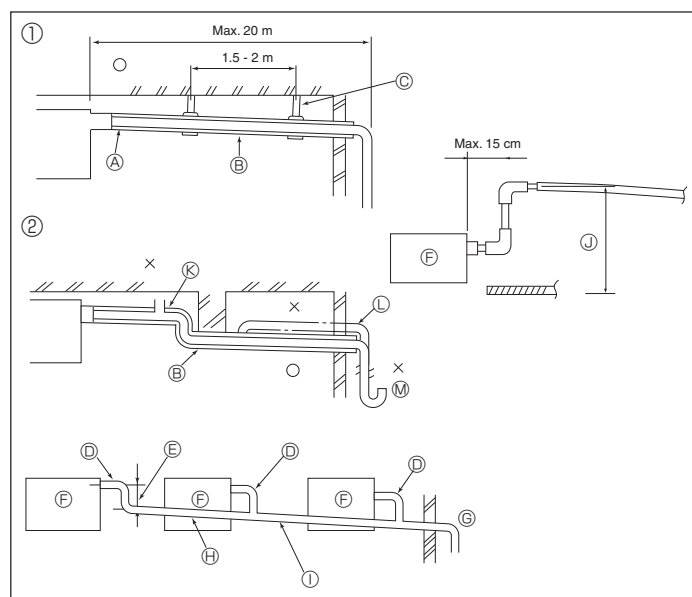

Fig. 5-1

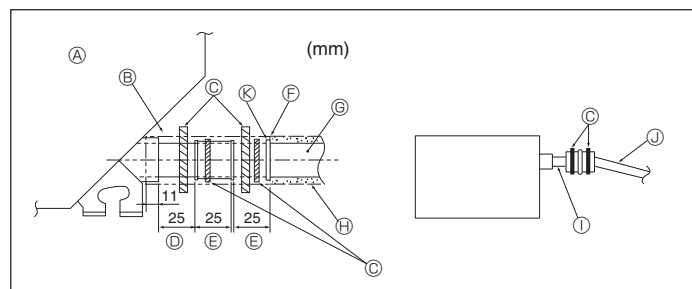

Fig. 5-2

4.3. Indoor unit (Fig. 4-3)

Heat insulation for refrigerant pipes:

- 1 Wrap the enclosed large-sized pipe cover around the gas pipe, making sure that the end of the pipe cover touches the side of the unit.
 - 2 Wrap the enclosed small-sized pipe cover around the liquid pipe, making sure that the end of the pipe cover touches the side of the unit.
 - 3 Secure both ends of each pipe cover with the enclosed bands. (Attach the bands 20 mm from the ends of the pipe cover.)
- After connecting the refrigerant piping to the indoor unit, be sure to test the pipe connections for gas leakage with nitrogen gas. (Check that there is no refrigerant leakage from the refrigerant piping to the indoor unit.)

4.4. For twin/triple combination

Refer to the outdoor unit installation manual.

5.1. Drainage piping work (Fig. 5-1)

- Use VP25 (O.D. ø32 PVC TUBE) for drain piping and provide 1/100 or more downward slope.
- Be sure to connect the piping joints using a polyvinyl type adhesive.
- Observe the figure for piping work.
- Use the included drain hose to change the extraction direction.

- | | |
|----------------------------------|-----------------|
| ① Correct piping | ③ Support metal |
| ② Wrong piping | ④ Air bleeder |
| ⑤ Insulation (9 mm or more) | ⑥ Raised |
| ⑦ Downward slope (1/100 or more) | ⑧ Odor trap |

Grouped piping

- | | |
|--|---|
| ⑨ O.D. ø32 PVC TUBE | ⑩ Downward slope (1/100 or more) |
| ⑪ Make it as large as possible | ⑪ O.D. ø38 PVC TUBE for grouped piping. (9 mm or more insulation) |
| ⑫ Indoor unit | ⑫ Up to 85 cm |
| ⑬ Make the piping size large for grouped piping. | |

1. Connect the drain socket (supplied with the unit) to the drain port. (Fig. 5-2) (Fix the tube using PVC adhesive then secure it with a band.)
 2. Install a locally purchased drain pipe (PVC pipe, O.D. ø32). (Fix the pipe using PVC adhesive then secure it with a band.)
 3. Insulate the tube and pipe. (PVC pipe, O.D. ø32 and socket)
 4. Check that drain flows smoothly.
 5. Insulate the drain port with insulating material, then secure the material with a band. (Both insulating material and band are supplied with the unit.)
- | | |
|----------------------------|---|
| ⑬ Unit | ⑮ Drain pipe (O.D. ø32 PVC TUBE) |
| ⑭ Insulating material | ⑯ Insulating material (purchased locally) |
| ⑰ Band | ⑰ Transparent PVC pipe |
| ⑱ Drain port (transparent) | ⑱ O.D. ø32 PVC TUBE (Slope 1/100 or more) |
| ⑲ Insertion margin | ⑲ Drain socket |
| ⑲ Matching | |

6. Electrical work

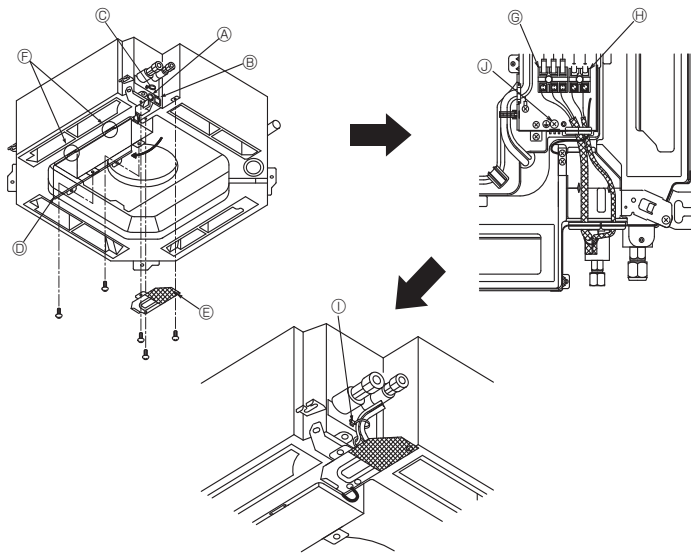

Fig. 6-1

6.1. Indoor unit (Fig. 6-1)

1. Remove the electrical wiring service panel.
 2. Remove the electrical box cover.
 3. Wire the power cable and control cable separately through the respective wiring entries given in the diagram.
- Do not allow slackening of the terminal screws.
 - Leave excess cable so that the electrical box cover can be suspended below the unit during servicing. (Approx. 50 to 100 mm)

- Ⓐ Entry for control cable
- Ⓑ Entry for power
- Ⓒ Clamp
- Ⓓ Electrical box cover
- Ⓔ Service panel for electrical wiring
- Ⓕ Temporary hook for electrical box cover
- Ⓖ Indoor / Outdoor unit connecting terminals
- Ⓗ Remote controller connector
- Ⓘ Secure with the clamp
- Ⓚ Earth terminal

6.1.1. Indoor unit power supplied from outdoor unit

The following connection patterns are available.

The outdoor unit power supply patterns vary on models.

1:1 System

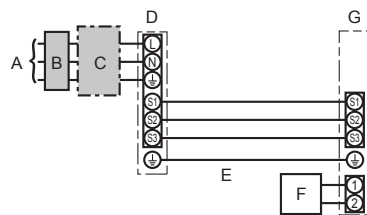

- A Outdoor unit power supply
- B Earth leakage breaker
- C Wiring circuit breaker or isolating switch
- D Outdoor unit
- E Indoor unit/outdoor unit connecting cables
- F Remote controller
- G Indoor unit

* Affix label A that is included with the manuals near each wiring diagram for the indoor and outdoor units.

Simultaneous twin/triple/quadruple system

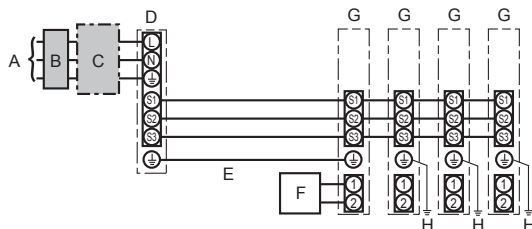

- A Outdoor unit power supply
- B Earth leakage breaker
- C Wiring circuit breaker or isolating switch
- D Outdoor unit
- E Indoor unit/outdoor unit connecting cables
- F Remote controller
- G Indoor unit
- H Indoor unit earth

* Affix label A that is included with the manuals near each wiring diagram for the indoor and outdoor units.

Indoor unit model		PLA	
Wiring Wire No. x size (mm ²)	Indoor unit-Outdoor unit	*1	3 × 1.5 (polar)
	Indoor unit-Outdoor unit earth	*1	1 × Min. 1.5
	Indoor unit earth		1 × Min. 1.5
	Remote controller-Indoor unit	*2	2 × 0.3 (Non-polar)
Circuit rating	Indoor unit (Heater) L-N	*3	—
	Indoor unit-Outdoor unit S1-S2	*3	AC 230 V
	Indoor unit-Outdoor unit S2-S3	*3	DC24 V
	Remote controller-Indoor unit	*3	DC12 V

*1. <For 35-140 outdoor unit application>

Max. 45 m

If 2.5 mm² used, Max. 50 m

If 2.5 mm² used and S3 separated, Max. 80 m

<For 200/250 outdoor unit application>

Max. 18 m

If 2.5 mm² used, Max. 30 m

If 4 mm² used and S3 separated, Max. 50 m

If 6 mm² used and S3 separated, Max. 80 m

*2. The 10 m wire is attached in the remote controller accessory. Max. 500 m

*3. The figures are NOT always against the ground.

S3 terminal has DC 24 V against S2 terminal. However between S3 and S1, these terminals are not electrically insulated by the transformer or other device.

Notes: 1. Wiring size must comply with the applicable local and national code.

2. Power supply cords and indoor unit/outdoor unit connecting cords shall not be lighter than polychloroprene sheathed flexible cord. (Design 60245 IEC 57)

3. Install an earth longer than other cables.

Warning:

Never splice the power cable or the indoor-outdoor connection cable, otherwise it may result in a smoke, a fire or communication failure.

6. Electrical work

6.1.2. Separate indoor unit/outdoor unit power supplies (For PUHZ application only)

The following connection patterns are available.

The outdoor unit power supply patterns vary on models.

1:1 System

* The indoor power supply terminal kit is required.

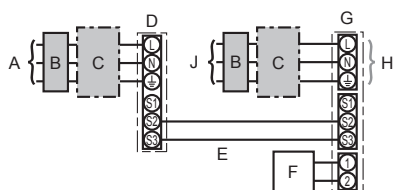

- A Outdoor unit power supply
- B Earth leakage breaker
- C Wiring circuit breaker or isolating switch
- D Outdoor unit
- E Indoor unit/outdoor unit connecting cables
- F Remote controller
- G Indoor unit
- H Option
- J Indoor unit power supply

* Affix label B that is included with the manuals near each wiring diagram for the indoor and outdoor units.

Simultaneous twin/triple/quadruple system

* The indoor power supply terminal kits are required.

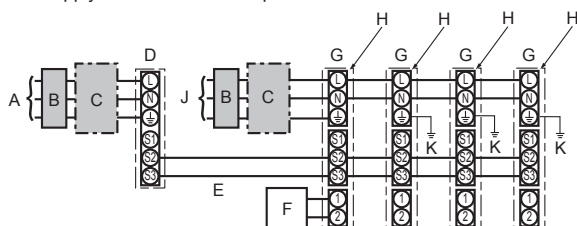

- A Outdoor unit power supply
- B Earth leakage breaker
- C Wiring circuit breaker or isolating switch
- D Outdoor unit
- E Indoor unit/outdoor unit connecting cables
- F Remote controller
- G Indoor unit
- H Option
- J Indoor unit power supply
- K Indoor unit earth

* Affix label B that is included with the manuals near each wiring diagram for the indoor and outdoor units.

If the indoor and outdoor units have separate power supplies, refer to the table below. If the indoor power supply terminal kit is used, change the indoor unit electrical box wiring referring to the figure in the right and the DIP switch settings of the outdoor unit control board.

	Indoor unit specifications								
Indoor power supply terminal kit (option)	Required								
Indoor unit electrical box connector connection change	Required								
Label affixed near each wiring diagram for the indoor and outdoor units	Required								
Outdoor unit DIP switch settings (when using separate indoor unit/outdoor unit power supplies only)	<table border="1" style="margin-left: auto; margin-right: auto;"> <tr> <td>ON</td> <td></td> <td></td> <td style="border: 2px solid black;">3</td> </tr> <tr> <td>OFF</td> <td>1</td> <td>2</td> <td></td> </tr> </table> <p style="text-align: center;">(SW8) Set the SW8-3 to ON.</p>	ON			3	OFF	1	2	
ON			3						
OFF	1	2							

* There are 3 types of labels (labels A, B and C). Affix the appropriate labels to the units according to the wiring method.

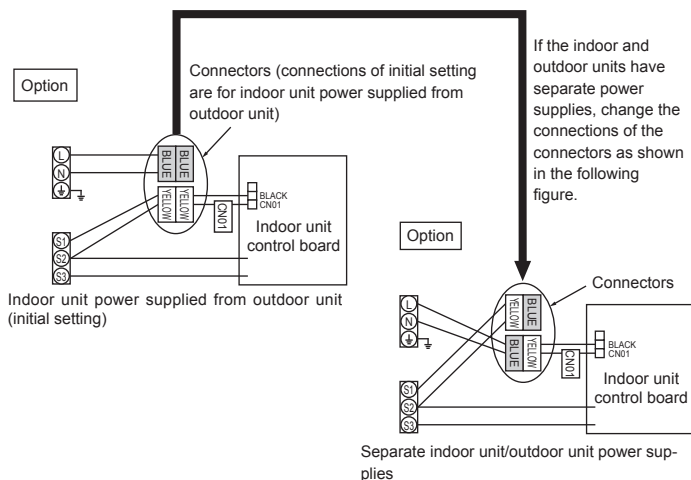

Indoor unit model		PLA
Indoor unit power supply		~N (single), 50 Hz, 230 V
Indoor unit input capacity	*1	16 A
Main switch (Breaker)		
Wiring Wire No. x wire size (mm ²)	Indoor unit power supply & earth	3 × Min. 1.5
	Indoor unit-Outdoor unit	*2 2 × Min. 0.3
	Indoor unit-Outdoor unit earth	-
	Remote controller-Indoor unit	*3 2 × 0.3 (Non-polar)
Circuit rating	Indoor unit L-N	*4 AC 230 V
	Indoor unit-Outdoor unit S1-S2	*4 -
	Indoor unit-Outdoor unit S2-S3	*4 DC24 V
	Remote controller-Indoor unit	*4 DC12 V

*1. A breaker with at least 3.0 mm contact separation in each pole shall be provided. Use earth leakage breaker (NV). The breaker shall be provided to ensure disconnection of all active phase conductors of the supply.

*2. Max. 120 m

*3. The 10 m wire is attached in the remote controller accessory. Max. 500 m

*4. The figures are NOT always against the ground.

- Notes:**
1. Wiring size must comply with the applicable local and national code.
 2. Power supply cords and indoor unit/outdoor unit connecting cords shall not be lighter than polychloroprene sheathed flexible cord. (Design 60245 IEC 57)
 3. Install an earth longer than other cables.

⚠ Warning:

Never splice the power cable or the indoor-outdoor connection cable, otherwise it may result in a smoke, a fire or communication failure.

6. Electrical work

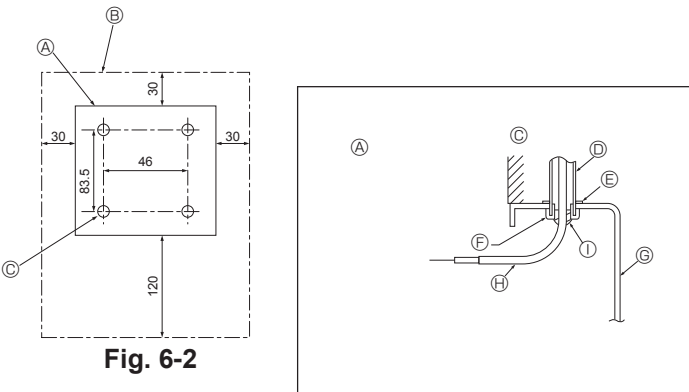

Fig. 6-2

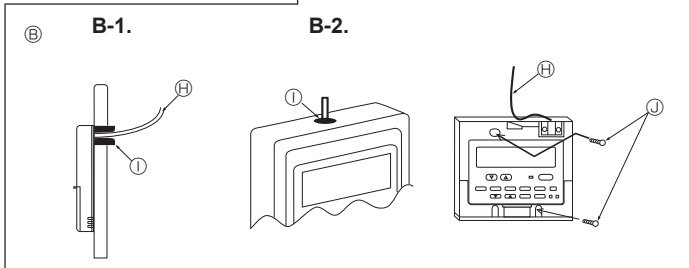

Fig. 6-3

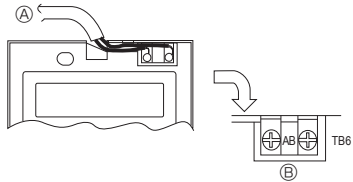

Fig. 6-4

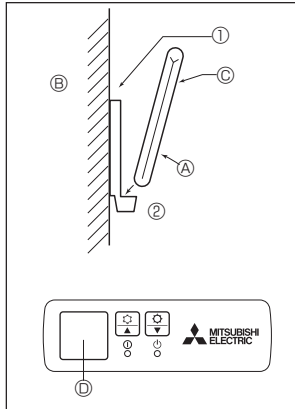

Fig. 6-5

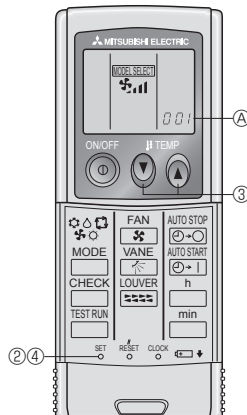

Fig. 6-6

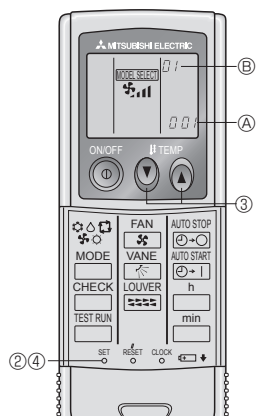

Fig. 6-7

6.2. Remote controller

6.2.1. For wired remote controller

1) Installing procedures

(1) Select an installing position for the remote controller. (Fig. 6-2)

The temperature sensors are located on both remote controller and indoor unit.

► Procure the following parts locally:

- 2 piece switch box
- Thin copper conduit tube
- Lock nuts and bushings

[Fig.6-2]

- Ⓐ Remote controller profile
- Ⓑ Required clearances surrounding the remote controller
- Ⓒ Installation pitch

(2) Seal the service entrance for the remote controller cord with putty to prevent possible invasion of dew drops, water, cockroaches or worms. (Fig. 6-3)

Ⓐ For installation in the switch box

Ⓑ For direct installation on the wall, select one of the following:

- Prepare a hole through the wall to pass the remote controller cord (in order to run the remote controller cord from the back), then seal the hole with putty.
- Run the remote controller cord through the cut-out upper case, then seal the cut-out notch with putty.

B-1. To lead the remote controller cord from the back of the controller

B-2. To run the remote controller cord through the upper portion

[Fig.6-3]

- Ⓒ Wall
- Ⓓ Conduit
- Ⓔ Lock nut
- Ⓕ Bushing
- Ⓖ Switch box
- Ⓗ Remote controller cord
- Ⓘ Seal with putty
- Ⓝ Wood screw

2) Connecting procedures (Fig. 6-4)

① Connect the remote controller cord to the terminal block.

- Ⓐ To TB5 on the indoor unit
- Ⓑ TB6 (No polarity)

3) 2 remote controllers setting

If 2 remote controllers are connected, set one to "Main" and the other to "Sub". For setting procedures, refer to "Function selection of remote controller" in the operation manual for the indoor unit.

6.2.2. For wireless remote controller

1) Installation area

- Area in which the remote controller is not exposed to direct sunshine.
- Area in which there is no nearby heating source.
- Area in which the remote controller is not exposed to cold (or hot) winds.
- Area in which the remote controller can be operated easily.
- Area in which the remote controller is beyond the reach of children.

2) Installation method (Fig. 6-5)

- ① Attach the remote controller holder to the desired location using 2 tapping screws.
- ② Place the lower end of the controller into the holder.

Ⓐ Remote controller Ⓑ Wall Ⓒ Display panel Ⓓ Receiver

- The signal can travel up to approximately 7 meters (in a straight line) within 45 degrees to both right and left of the center line of the receiver.

3) Setting (Fig. 6-6)

- ① Insert batteries.
- ② Press the SET button with something sharp at the end.
MODEL SELECT blinks and Model No. is lighted.
- ③ Press the temp buttons to set the Model No.
If you mistook the operation, press the ON/OFF button and operate again from procedure ②.
- ④ Press the SET button with something sharp at the end.
MODEL SELECT and Model No. are lighted for 3 seconds, then turned off.

Indoor	Outdoor	Ⓐ Model No.
PLA	PUH, PUHZ, SUZ	001
	PU	033

4) Automatic fan speed setting (For wireless remote controller)

It is necessary to set for wireless remote controller only when automatic fan speed is not set at initial setting.

It is not necessary to set for wired remote controller with automatic fan speed at initial setting.

1. Press the SET button with something sharp at the end.
Operate when display of remote controller is off.
MODEL SELECT blinks and Model No. is lighted Ⓐ.
2. Press the AUTO STOP button.
MODEL SELECT blinks and setting No. is lighted Ⓑ.
(Setting No.01: without automatic fan speed)
3. Press the temp buttons to set the setting No.02.
(Setting No.02:with automatic fan speed)
If you mistook the operation, press the ON/OFF button and operate again from procedure 2.
4. Press the SET button with something sharp at the end.
MODEL SELECT and Model No. are lighted for 3 seconds, then turned off.

6. Electrical work

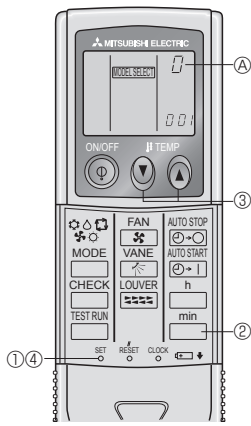

Fig. 6-8

5) Assigning a remote controller to each unit (Fig. 6-8)

Each unit can be operated only by the assigned remote controller.

Make sure each pair of an indoor unit PC board and a remote controller is assigned to the same pair No.

6) Wireless remote controller pair number setting operation

① Press the SET button with something sharp at the end. Start this operation from the status of remote controller display turned off.

MODEL SELECT blinks and Model No. is lighted.

② Press the \square_{min} button twice continuously. Pair No. "0" blinks.

③ Press the temp \odot \odot buttons to set the pair number you want to set.

If you mistook the operation, press the ON/OFF \odot button and operate again from procedure 2.

④ Press the SET button with something sharp at the end.

Set pair number is lighted for 3 seconds then turned off.

④ Pair No. of wireless remote controller	Indoor PC board
0	Initial setting
1	Cut J41
2	Cut J42
3-9	Cut J41, J42

6.3. Function settings

6.3.1. Function setting on the unit (Selecting the unit functions)

1) For wired remote controller (Fig. 6-9)

Changing the power voltage setting

• Be sure to change the power voltage setting depending on the voltage used.

① Go to the function setting mode.

Switch OFF the remote controller.

Press the FILTER $\text{\textcircled{A}}$ and TEST RUN $\text{\textcircled{B}}$ buttons simultaneously and hold them for at least 2 seconds. FUNCTION will start to blink.

② Use the \odot buttons to set the refrigerant address (III) to 00.

③ Press \odot button and [-] will start to blink in the unit number (IV) display.

④ Use the \odot buttons to set the unit number (IV) to 00.

⑤ Press the MODE button $\text{\textcircled{E}}$ to designate the refrigerant address/unit number. [-] will blink in the mode number (I) display momentarily.

⑥ Press the \odot buttons to set the mode number (I) to 04.

⑦ Press the \odot button and the current set setting number (II) will blink.

Use the \odot button to switch the setting number in response to the power supply voltage to be used.

Power supply voltage

240 V : setting number = 1

220 V, 230 V : setting number = 2

⑧ Press the MODE button $\text{\textcircled{E}}$ and mode and the setting number (I) and (II) will change to being on constantly and the contents of the setting can be confirmed.

⑨ Press the FILTER $\text{\textcircled{A}}$ and TEST RUN $\text{\textcircled{B}}$ buttons simultaneously for at least 2 seconds. The function selection screen will disappear momentarily and the air conditioner OFF display will appear.

2) For wireless remote controller (Fig. 6-10)

Changing the power voltage setting

• Be sure to change the power voltage setting depending on the voltage used.

① Going to the function select mode

Press the $\text{\textcircled{F}}$ button twice continuously.

(Start this operation from the status of remote controller display turned off.)

CHECK is lighted and "00" blinks.

Press the \odot temp button $\text{\textcircled{C}}$ once to set "50". Direct the wireless remote controller toward the receiver of the indoor unit and press the \square_{h} button $\text{\textcircled{A}}$.

② Setting the unit number

Press the \odot \odot temp buttons $\text{\textcircled{C}}$ and $\text{\textcircled{D}}$ to set the unit number "00". Direct the wireless remote controller toward the receiver of the indoor unit and press the \square_{min} button $\text{\textcircled{B}}$.

③ Selecting a mode

Enter 04 to change the power voltage setting using the \odot \odot temp buttons $\text{\textcircled{C}}$ and $\text{\textcircled{D}}$. Direct the wireless remote controller toward the receiver of the indoor unit and press the \square_{h} button $\text{\textcircled{A}}$.

Current setting number: 1 = 1 beep (1 second)

2 = 2 beeps (1 second each)

3 = 3 beeps (1 second each)

④ Selecting the setting number

Use the \odot \odot temp buttons $\text{\textcircled{C}}$ and $\text{\textcircled{D}}$ to change the power voltage setting to 01 (240 V). Direct the wireless remote controller toward the sensor of the indoor unit and press the \square_{h} button $\text{\textcircled{A}}$.

⑤ To select multiple functions continuously

Repeat steps ③ and ④ to change multiple function settings continuously.

⑥ Complete function selection

Direct the wireless remote controller toward the sensor of the indoor unit and press the $\text{\textcircled{E}}$ button.

Note: Whenever changes are made to the function settings after installation or maintenance, be sure to record the changes with a mark in the "Setting" column of the Function table.

6.3.2. Function setting on the remote controller

Refer to the indoor unit operation manual.

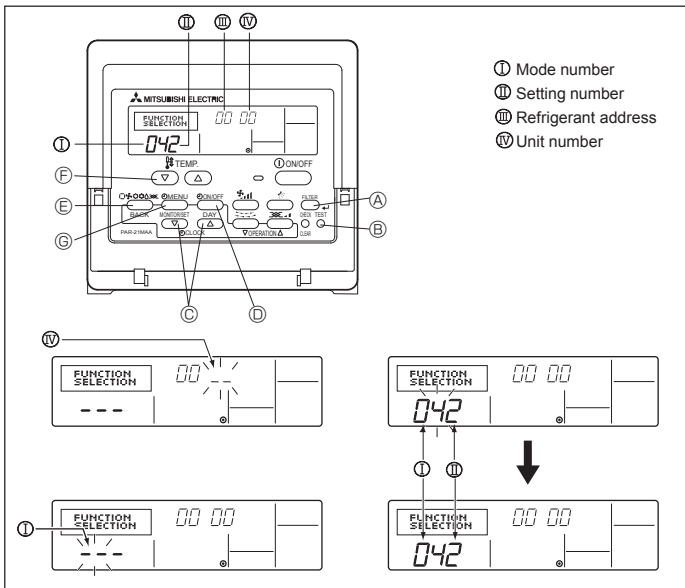

Fig. 6-9

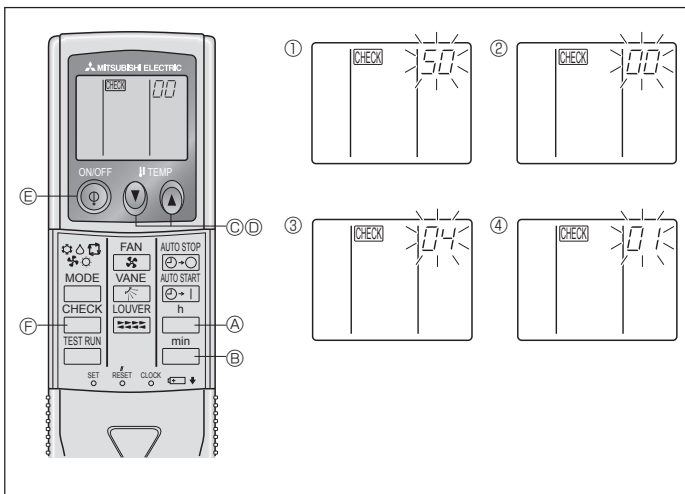

Fig. 6-10

6. Electrical work

Function table

Select unit number 00

Mode	Settings	Mode no.	Setting no.	Initial setting	setting
Power failure automatic recovery	Not available	01	1		
	Available *1		2	○ *2	
Indoor temperature detecting	Indoor unit operating average	02	1	○	
	Set by indoor unit's remote controller		2		
	Remote controller's internal sensor		3		
LOSSNAY connectivity	Not Supported	03	1	○	
	Supported (indoor unit is not equipped with outdoor-air intake)		2		
	Supported (indoor unit is equipped with outdoor-air intake)		3		
Power voltage	240 V	04	1		
	220 V, 230 V		2	○	

Select unit numbers 01 to 03 or all units (AL [wired remote controller]/07 [wireless remote controller])

Mode	Settings	Mode no.	Setting no.	Initial setting	setting
Filter sign	100Hr	07	1		
	2500Hr		2	○	
	No filter sign indicator		3		
Fan speed	Silent	08	1		
	Standard		2	○	
	High ceiling		3		
No. of air outlets	4 directions	09	1	○	
	3 directions		2		
	2 directions		3		
Installed options (high-performance filter)	Not supported	10	1	○	
	Supported		2		
Up/down vane setting	Equipped with vanes (vaner angle setup ③)	11	1		
	Equipped with vanes (vaner angle setup ①)		2		
	Equipped with vanes (vaner angle setup ②)		3	○	

*1 When the power supply returns, the air conditioner will start 3 minutes later.

*2 Power failure automatic recovery initial setting depends on the connecting outdoor unit.

6.3.3 How to set the fixed up/down air direction (Only for wired remote controller and PUHZ, PU(H) application)

- Only the particular outlet can be fixed to certain direction with the procedures below. Once fixed, only the set outlet is fixed every time air conditioner is turned on. (Other outlets follow UP/DOWN air direction setting of the remote controller.)

■ Explanation of word

- "Refrigerant address No." and "Unit No." are the numbers given to each air conditioner.
- "Outlet No." is the number given to each outlet of air conditioner. (Refer to the right.)
- "Up/Down air direction" is the direction (angle) to fix.

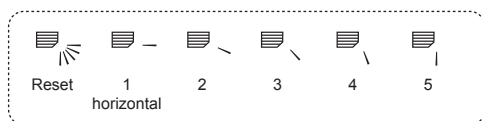

Remote controller setting

The airflow direction of this outlet is controlled by the airflow direction setting of remote controller.

Fixed setting

The airflow direction of this outlet is fixed in particular direction.

※ When it is cold because of direct airflow, the airflow direction can be fixed horizontally to avoid direct airflow.

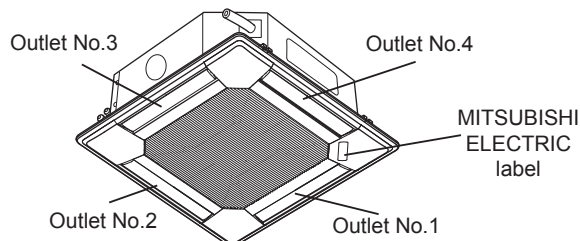

Note: "0" indicates all outlets.

6. Electrical work

Operation buttons (During the fixed airflow direction mode)

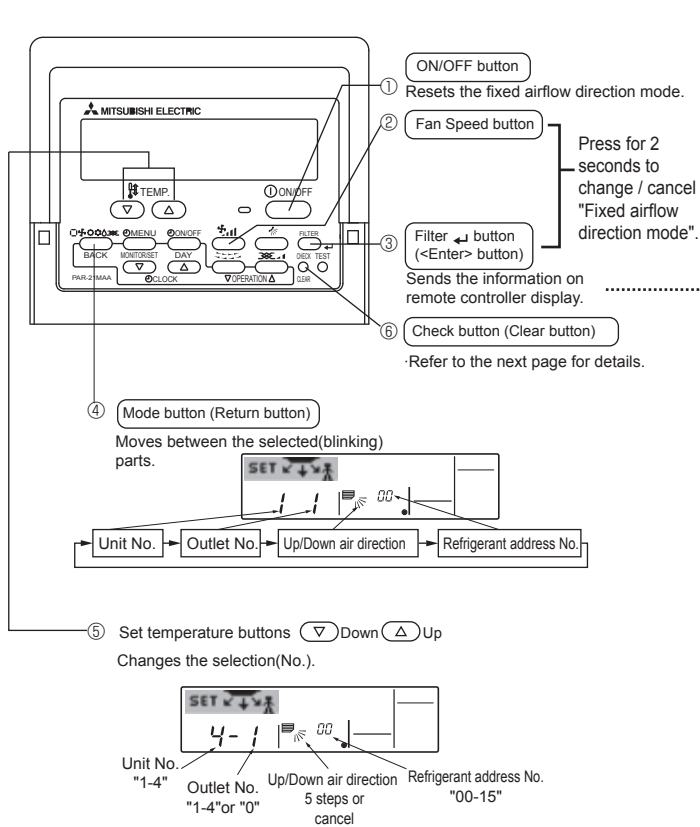

■ Press the button with either refrigerant address No., unit No. or outlet No. blinking, ...

Only the air conditioner with the No. on remote controller and its outlet are set to the setting 5 of the airflow direction. (Other outlets are closed.)
It is used to identify the air conditioner and outlet to set.

■ Press the button with Up/Down air direction indicator blinking, ...

Attention

Only the air conditioner with the No. on Remote controller and its outlet are fixed at "Up/Down air direction" which is blinking.
This is used only to decide direction conclusively.
Attention: Be careful not to set wrong air conditioner.

< Process for setting >

[1] To turn off air conditioner and change the remote controller to "Fixed airflow direction mode"

1. Press ON/OFF button ① to turn off the air conditioner.
2. Press Fan Speed button ② and Filter (Enter) button ③ for more than 2 seconds simultaneously and it becomes the fixed airflow direction mode after a while.

"Fixed airflow direction mode" display

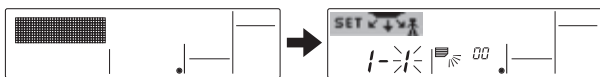

※ Air blows downward after it becomes "fixed airflow direction mode".

[2] To select and identify the outlet to set

1. Press Set Temperature button ⑤ to change number with the outlet No. blinking. Select outlet No. to set.

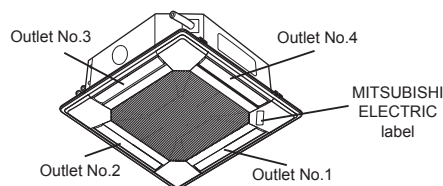
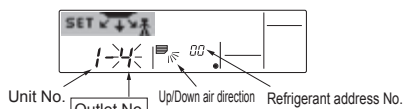

Note: "0" indicates all outlets.

2. Press Filter (Enter) button ③ to send the information on remote controller.
3. Wait for 15 seconds. How does the air conditioner run?
 - Only the air from the selected outlet blows downward.
 - Go to step [3].
 - Air from the wrong outlet blows downward.
 - Repeat 1 and set again.
 - All outlets are closed.
 - The numbers of the air conditioner (refrigerant address No., Unit No.) are wrong. Refer to How to find air conditioner No..

[3] To fix air direction

1. Press Mode button (Return button) ④ to blink Up/Down air direction indicator.
2. Press Set Temperature button ⑤ until the direction to set is chosen.
3. Press Filter (Enter) button ③ to send the information on remote controller to air conditioner.
4. Wait for 15 seconds. How does the air conditioner run?
 - Airflow direction is set in the selected direction.
 - The fixed setting completed (Go to step [4].)
 - Airflow direction is set in the wrong direction.
 - Repeat 2. and set again.

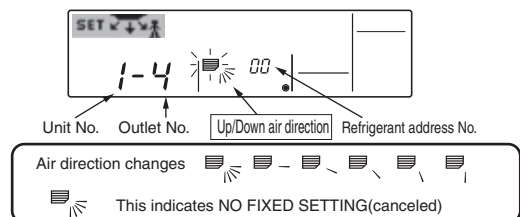

[4] To cancel "Fixed airflow direction mode"

1. Press ON/OFF button ① to cancel "Fixed airflow direction mode". It is also canceled by pressing Fan Speed button ② and Filter (Enter) button ③ for more than 2 seconds simultaneously.
2. Do not operate remote controller for 30 seconds after the "Fixed airflow direction mode" is canceled. It does not accept even if it is operated.

6. Electrical work

■ How to find air conditioner No.

Each air conditioner has its own refrigerant address No. and unit No. (Example below).

To find air conditioner No. to set, refer to the procedures below.

Air conditioner No. is found by its airflow direction with the unit No. changed one after the other.

Flow of procedure

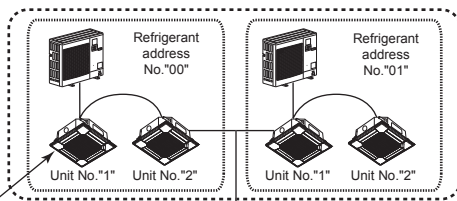

As for this air conditioner, air conditioner No. is "unit No. 1" of refrigerant address "0".

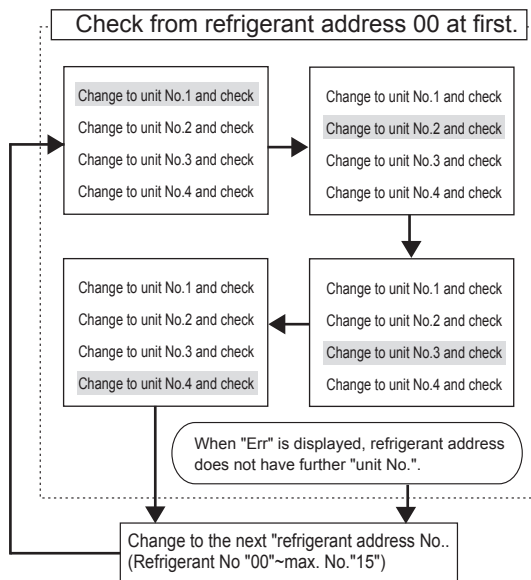

<Process to find air conditioner No.>

[1] To check refrigerant address No. 00 and unit No. 1

1. Press Mode button (Return button) ④ and unit No. or refrigerant address No. blinks.

Adjust refrigerant address No. to "00" and unit No. "1" with Set Temperature button ⑤.

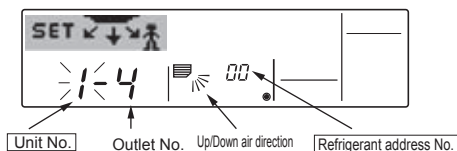

2. Press Filter ← button ③ to send the information on remote controller.

3. Wait for 15 seconds. How does the air conditioner run?

→ Only air from the outlet of which No. displayed on remote controller blows downward.

→ Refrigerant address No. 00 and unit No. 1 are the air conditioner No..

→ All outlets are closed.

→ Go to step [2].

[2] To check by changing unit No. one after the other (Maximum unit No. is 4)

1. Press Mode button (Return button) ④ and unit No. blinks.

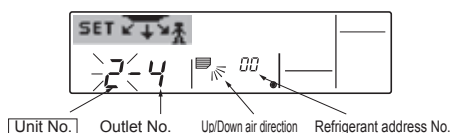

Adjust to the next unit No. with Set Temperature button ⑤.

(refrigerant address No. 00 is remained.)

2. Press Filter ← button ③ to send the information on remote controller.

3. Wait for 15 seconds. How does the air conditioner run?

→ Only air from the outlet which No. displayed on remote controller blows downward.

→ No. displayed in remote controller is air conditioner No. (Checking completed)

→ All outlets are closed.

→ Repeat [1] and check. (If all the numbers are checked up to No. 4 and is not found, go to [3].)

→ "Err" is displayed on remote controller.

→ The refrigerant address does not have further unit No.. (Go to [3].)

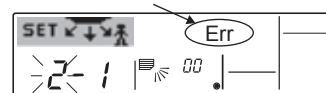

[3] To check Unit No. of following refrigerant address No. (Maximum refrigerant address No. is 15)

1. Press Mode button (Return button) ④ to blink refrigerant address No.. Adjust refrigerant No. with Set Temperature button ⑤.

* By changing refrigerant address, unit No. and outlet No. turn to initial display.

2. Go back to [2] and check Unit No. again from Unit No. 1 in order.

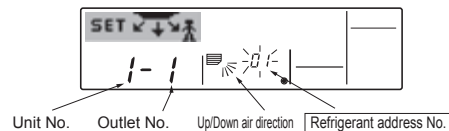

To clear fixed setting

To clear all fixed setting (reset to initial setting), press check button (clear button) ⑥ for more than 3 seconds in fixed airflow direction mode.

Display of remote controller blinks and the set information is cleared.

Note: This operation clears the fixed setting information of all air conditioner connected to the remote controller.

7. Test run

7.1. Before test run

- ▶ After completing installation and the wiring and piping of the indoor and outdoor units, check for refrigerant leakage, looseness in the power supply or control wiring, wrong polarity, and no disconnection of one phase in the supply.
- ▶ Use a 500-volt megohmmeter to check that the resistance between the power supply terminals and ground is at least 1.0 MΩ.

- ▶ Do not carry out this test on the control wiring (low voltage circuit) terminals.

⚠ Warning:
Do not use the air conditioner if the insulation resistance is less than 1.0 MΩ.

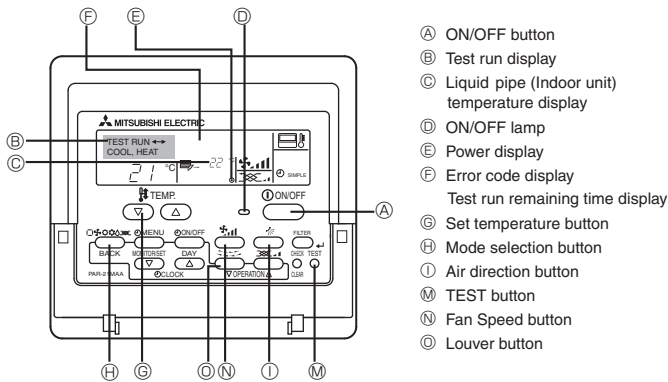

Fig. 7-1

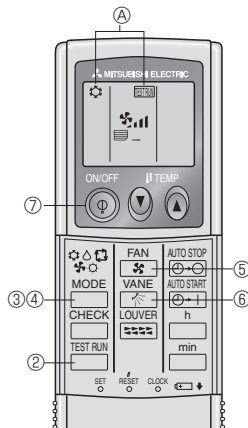

Fig. 7-2

7.2. Test run

The following 3 methods are available.

7.2.1. Using wired remote controller (Fig. 7-1)

- ① Turn on the power at least 12 hours before the test run.
- ② Press the [TEST] button twice. ➡ "TEST RUN" liquid crystal display
- ③ Press the [Mode selection] button and switch to the cooling (or heating) mode. ➡ Make sure that cold (or warm) wind is blown out.
- ④ Press the [Fan speed] button. ➡ Make sure that the wind speed is switched.
- ⑤ Press the [Air direction button] or [Louver button]. ➡ Check operation of the vane or louver.
- ⑥ Check operation of the outdoor unit fan.
- ⑦ Release test run by pressing the [ON/OFF] button. ➡ Stop
- ⑧ Register a telephone number.
The telephone number of the repair shop, sales office, etc., to contact if an error occurs can be registered in the remote controller. The telephone number will be displayed when an error occurs. For registration procedures, refer to the operation manual for the indoor unit.

7.2.2. Using wireless remote controller (Fig. 7-2)

- ① Turn on the power to the unit at least 12 hours before the test run.
- ② Press the ^{TEST RUN} button twice continuously.
(Start this operation from the status of remote controller display turned off.)
A ^{TEST RUN} and current operation mode are displayed.
- ③ Press the ^{MODE} button (☉ ☼ ☽ ☿ ☿) to activate COOL ☉ mode, then check whether cool air is blown out from the unit.
- ④ Press the ^{MODE} button (☉ ☼ ☽ ☿ ☿) to activate HEAT ☼ mode, then check whether warm air is blown out from the unit.
- ⑤ Press the ^{FAN} button and check whether fan speed changes.
- ⑥ Press the ^{VANE} button and check whether the auto vane operates properly.
- ⑦ Press the ON/OFF button to stop the test run.

Note:

- Point the remote controller towards the indoor unit receiver while following steps ② to ⑦.
- It is not possible to run the TEST RUN in FAN, DRY or AUTO mode.

7.2.3. Using SW4 in outdoor unit

Refer to the outdoor unit installation manual.

7.3. Self-check

7.3.1. Wired remote controller (Fig. 7-3)

- ① Turn on the power.
- ② Press the [CHECK] button twice.
- ③ Set refrigerant address with [TEMP] button if system control is used.
- ④ Press the [ON/OFF] button to stop the self-check.

- A CHECK button
- B Refrigerant address
- C TEMP. button
- D IC: Indoor unit
OC: Outdoor unit
- E Check code
- F Unit address

7.3.2. Wireless remote controller (Fig. 7-4)

- ① Turn on the power.
- ② Press the ^{CHECK} button twice.
(Start this operation from the status of remote controller display turned off.)
A ^{CHECK} begins to light.
B "00" begins to blink.
- ③ While pointing the remote controller toward the unit's receiver, press the ^h button. The check code will be indicated by the number of times that the buzzer sounds from the receiver section and the number of blinks of the operation lamp.
- ④ Press the ON/OFF button to stop the self-check.

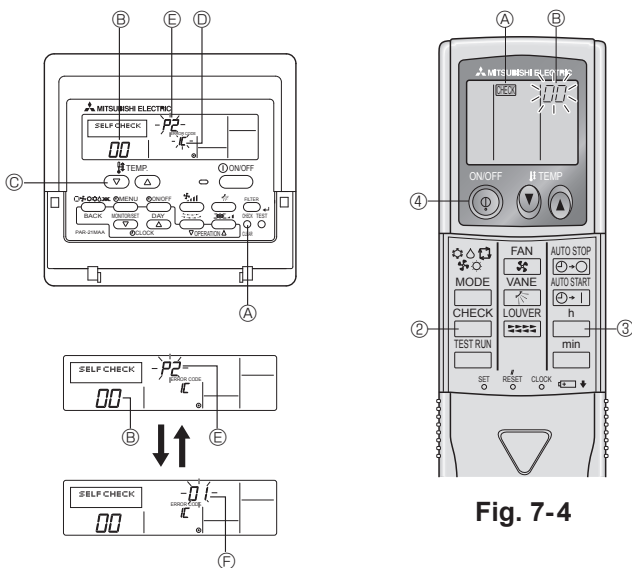

Fig. 7-3

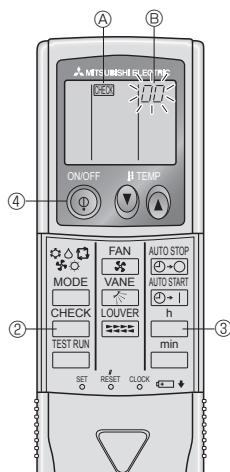
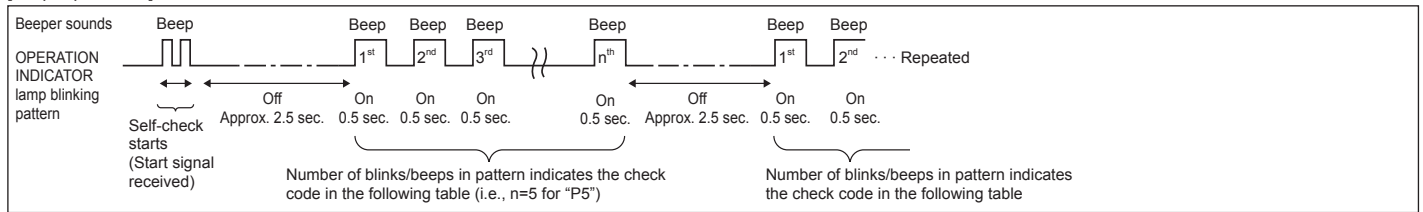

Fig. 7-4

7. Test run

- Refer to the following tables for details on the check codes. (Wireless remote controller)

[Output pattern A]



[Output pattern B]

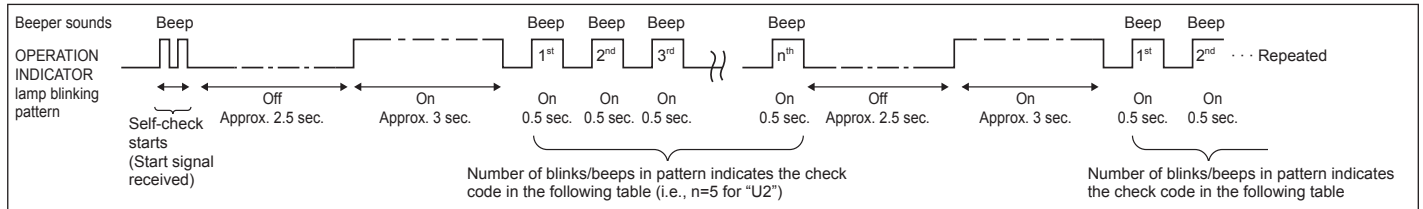

[Output pattern A] Errors detected by indoor unit

Wireless remote controller	Wired remote controller	Symptom	Remark
Beeper sounds/OPERATION INDICATOR lamp blinks (Number of times)	Check code		
1	P1	Intake sensor error	
2	P2	Pipe (TH2) sensor error	
	P9	Pipe (TH5) sensor error	
3	E6, E7	Indoor/outdoor unit communication error	
4	P4	Drain sensor error / Float switch connector open	
5	P5	Drain pump error	
	PA	Forced compressor error	
6	P6	Freezing/Overheating protection operation	
7	EE	Communication error between indoor and outdoor units	
8	P8	Pipe temperature error	
9	E4	Remote controller signal receiving error	
10	—	—	
11	—	—	
12	Fb	Indoor unit control system error (memory error, etc.)	
14	PL	Refrigerant circuit abnormal	
No sound	E0, E3	Remote controller transmission error	
No sound	E1, E2	Remote controller control board error	
No sound	----	No corresponding	

[Output pattern B] Errors detected by unit other than indoor unit (outdoor unit, etc.)

Wireless remote controller	Wired remote controller	Symptom	Remark
Beeper sounds/OPERATION INDICATOR lamp blinks (Number of times)	Check code		
1	E9	Indoor/outdoor unit communication error (Transmitting error) (Outdoor unit)	For details, check the LED display of the outdoor controller board.
2	UP	Compressor overcurrent interruption	
3	U3, U4	Open/short of outdoor unit thermistors	
4	UF	Compressor overcurrent interruption (When compressor locked)	
5	U2	Abnormal high discharging temperature/49C worked/insufficient refrigerant	
6	U1, Ud	Abnormal high pressure (63H worked)/Overheating protection operation	
7	U5	Abnormal temperature of heat sink	
8	U8	Outdoor unit fan protection stop	
9	U6	Compressor overcurrent interruption/Abnormal of power module	
10	U7	Abnormality of super heat due to low discharge temperature	
11	U9, UH	Abnormality such as overvoltage or voltage shortage and abnormal synchronous signal to main circuit/Current sensor error	
12	—	—	
13	—	—	
14	Others	Other errors (Refer to the technical manual for the outdoor unit.)	

*1 If the beeper does not sound again after the initial 2 beeps to confirm the self-check start signal was received and the OPERATION INDICATOR lamp does not come on, there are no error records.

*2 If the beeper sounds 3 times continuously "beep, beep, beep (0.4 + 0.4 + 0.4 sec.)" after the initial 2 beeps to confirm the self-check start signal was received, the specified refrigerant address is incorrect.

- On wireless remote controller
The continuous buzzer sounds from receiving section of indoor unit.
Blink of operation lamp
- On wired remote controller
Check code displayed in the LCD.

7. Test run

- If the unit cannot be operated properly after test run, refer to the following table to find the cause.

Symptom		LED 1, 2 (PCB in outdoor unit)	Cause
Wired remote controller			
PLEASE WAIT	For about 2 minutes after power-on	After LED 1, 2 are lighted, LED 2 is turned off, then only LED 1 is lighted. (Correct operation)	•For about 2 minutes after power-on, operation of the remote controller is not possible due to system start-up. (Correct operation)
PLEASE WAIT →Error code	Subsequent to about 2 minutes after power-on	Only LED 1 is lighted. → LED 1, 2 blink.	•Connector for the outdoor unit's protection device is not connected. Reverse or open phase wiring for the outdoor unit's power terminal block (L1, L2, L3)
Display messages do not appear even when operation switch is turned ON (operation lamp does not light up).		Only LED 1 is lighted. → LED 1 blinks twice, LED 2 blinks once.	• Incorrect wiring between indoor and outdoor units (incorrect polarity of S1, S2, S3) •Remote controller wire short

On the wireless remote controller with condition above, following phenomena take place.

- No signals from the remote controller are accepted.
- Operation lamp is blinking.
- The buzzer makes a short ping sound.

Note:

Operation is not possible for about 30 seconds after cancellation of function selection. (Correct operation)

For description of each LED (LED1, 2, 3) provided on the indoor controller, refer to the following table.

LED 1 (power for microcomputer)	Indicates whether control power is supplied. Make sure that this LED is always lit.
LED 2 (power for remote controller)	Indicates whether power is supplied to the remote controller. This LED lights only in the case of the indoor unit which is connected to the outdoor unit refrigerant address "0".
LED 3 (communication between indoor and outdoor units)	Indicates state of communication between the indoor and outdoor units. Make sure that this LED is always blinking.

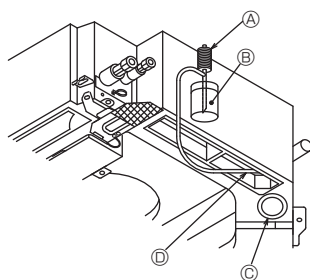

- Ⓐ Water supply pump
 - Ⓑ Water (about 1000cc)
 - Ⓒ Drain plug
 - Ⓓ Pour water through outlet
- Be careful not to spray water into the drain pump mechanism.

Fig. 7-5

7.4. Check of drainage (Fig. 7-5)

- Ensure that the water is being properly drained out and that no water is leaking from joints.

When electric work is completed.

- Pour water during cooling operation and check.

When electric work is not completed.

- Pour water during emergency operation and check.

* Drain pan and fan are activated simultaneously when single phase 220-240V is turned on to S1 and S2 on terminal block after the connector (SWE) on controller board in the electrical branch box is set to ON.

Be sure to turn it back to the former state after work.

8. System control

Refer to the outdoor unit installation manual.

9. Installing the grille

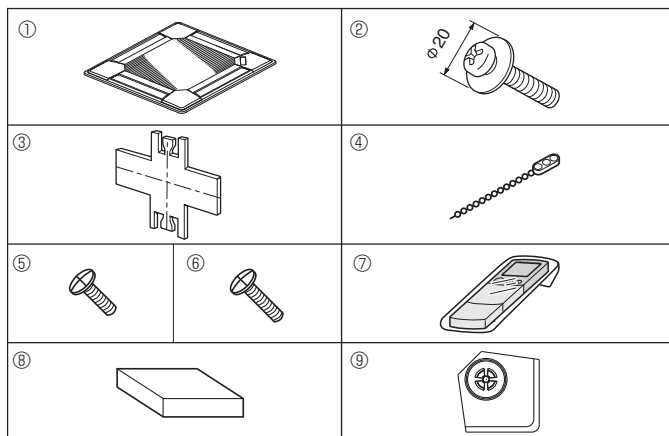

Fig. 9-1

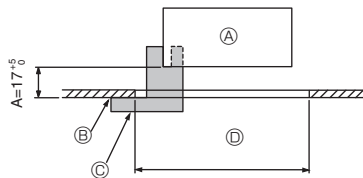

Fig. 9-2

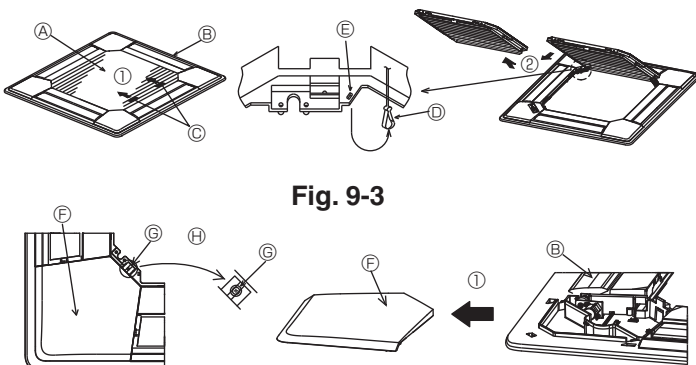

Fig. 9-3

Fig. 9-4

	4-directional	3-directional
Blowout direction patterns	1 pattern: initial setting 	4 patterns: one air outlet fully closed
Blowout direction patterns	2-directional 6 patterns: 2 air outlet fully closed 	

Table 1

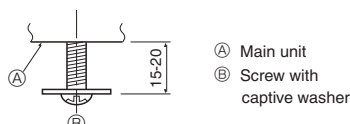

Fig. 9-5

9.1. Checking the contents (Fig. 9-1)

- This kit contains this manual and the following parts.

	Accessory name	Q'ty	Remarks
①	Grille	1	950 × 950 (mm)
②	Screw with captive washer	4	M5 × 0.8 × 25
③	Gauge	1	(Divided into 4 parts)
④	Fastener	3	
⑤	Screw	4	4 × 8
⑥	Screw	1	4 × 12
⑦	Wireless remote controller	1	for PLP-6BALM, PLP-6BALME
⑧	Wired remote controller	1	for PLP-6BAMD, PLP-6BAMDE
⑨	i-see sensor corner panel	1	for PLP-6BAE, PLP-6BAMDE, PLP-6BALME

9.2. Preparing to attach the grille (Fig. 9-2)

- With the gauge ③ supplied with this kit, adjust and check the positioning of the unit relative to the ceiling. If the unit is not properly positioned relative to the ceiling, it may allow air leaks or cause condensation to collect.
- Make sure that the opening in the ceiling is within the following tolerances: 860 × 860 - 910 × 910
- Make sure that A is performed within 17-22 mm. Damage could result by failing to adhere to this range.
 - Ⓐ Main unit
 - Ⓑ Ceiling
 - Ⓒ Gauge ③ (inserted into the unit)
 - Ⓓ Ceiling opening dimensions

9.2.1. Removing the intake grille (Fig. 9-3)

- Slide the levers in the direction indicated by the arrows ① to open the intake grille.
- Unlatch the hook that secures the grille.
 - * Do not unlatch the hook for the intake grille.
- With the intake grille in the "open" position, remove the hinge of the intake grille from the grille as indicated by the arrows ②.

9.2.2. Removing the corner panel (Fig. 9-4)

- Remove the screw from the corner of the corner panel. Slide the corner panel as indicated by the arrow ① to remove the corner panel.

[Fig. 9-3] [Fig. 9-4]

- Ⓐ Intake grille
- Ⓑ Grille
- Ⓒ Intake grille levers
- Ⓓ Grille hook
- Ⓔ Hole for the grille's hook
- Ⓕ Corner panel
- Ⓖ Screw
- Ⓗ Detail

9.3. Selection of the air outlets

For this grille the discharge direction is available in 11 patterns. Also, by setting the remote controller to the appropriate settings, you can adjust the air-flow and speed. Select the required settings from the Table 1 according to the location in which you want to install the unit.

- Decide on the discharge direction pattern.
- Be sure to set the remote controller to the appropriate settings according to the number of air outlets and the height of the ceiling on which the unit will be installed.

Note:

For 3 and 2-directional, please use the air outlet shutter plate (option).

9.4. Installing the grille

9.4.1. Preparations (Fig. 9-5)

- Install the 2 enclosed screws with washer ② in the main unit (at the corner drain pipe area and at the opposite corner) as shown in the diagram.

9. Installing the grille

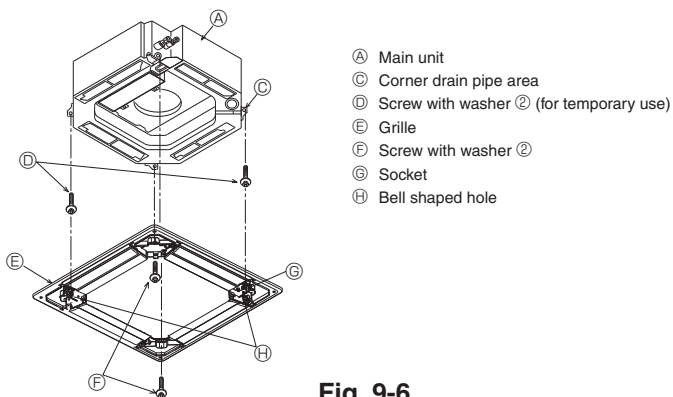

Fig. 9-6

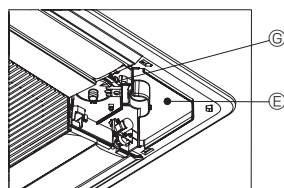

Fig. 9-7

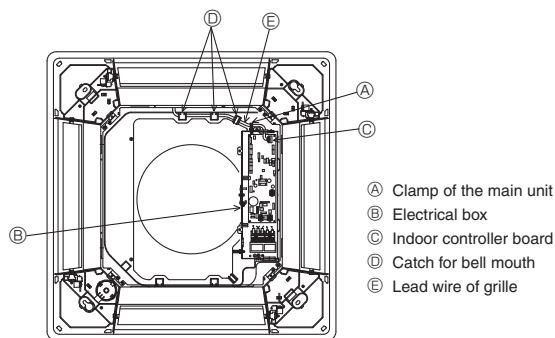

Fig. 9-8

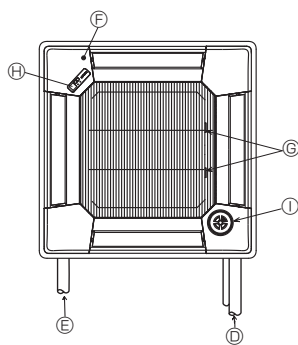
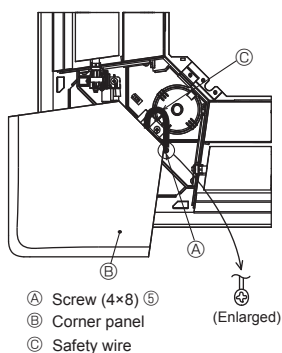

Fig. 9-9

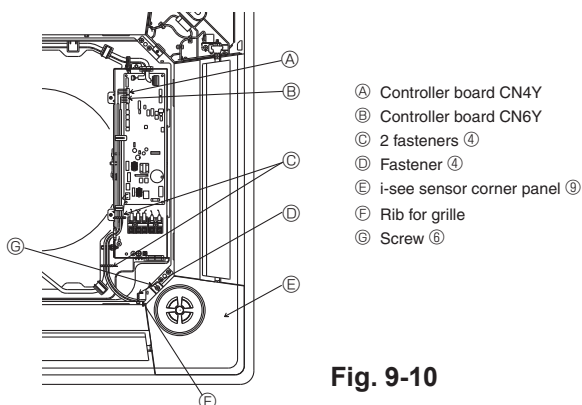

Fig. 9-10

9.4.2. Temporary installation of the grille (Fig. 9-6)

- Temporarily secure the grille using the bell shaped holes by putting the socket of the grille marked ③ on the corner drain pipe area of the main unit.
 - * Make sure that the lead wiring of the grille does not get pinched between the grille and the main unit.

9.4.3. Securing the grille (Fig. 9-7)

- Secure the grille to the main unit by tightening the previously installed 2 screws (with captive washer) as well as the 2 remaining screws (with captive washer).
 - * Make sure that there are no gaps between the main unit and the grille or the grille and the ceiling.

Fixing gaps between the grille and the ceiling

With the grille attached, adjust the height of the main unit to close the gap.

⚠ Caution:

When tightening the screw with captive washer ②, tighten it at a torque of 4.8 N·m or less. Never use an impact screwdriver.

- It may result in parts damage.

9.4.4. Wire connection (Fig. 9-8)

- Remove the 2 screws fixing the cover of electrical branch box of the unit and open the cover.
 - Be sure to connect the connector (white, 20-pole) for vane motor of the grille to CNV connector of controller board of the unit.
 - As for PLP-6BALM (E), the connector of wireless sensor cable is also connected to connector CN90 on indoor controller board.
- The lead wire of grille is passed through the catch of bell mouth of the unit perfectly. The remaining lead wire is tied with clamp of the unit and put the cover of the unit again with 2 screws.

Note:

Do not put the remaining lead wire in electrical branch box of the unit.

9.5. Installing the intake grille (Fig. 9-9)

Note:

When reinstalling the corner panels (each with a safety wire attached), connect the other end of each safety wire to the grille using a screw (4 pcs, 4x8) as shown in the illustration.

- *If the corner panels are not attached, they may fall off while the unit is operating.
- Perform the procedure that is described in "9.2. Preparing to attach the grille" in reverse order to install the intake grille and the corner panel.
- Multiple units can be installed with grille so that the position of the logo on each corner panel is consistent with the other units regardless of the orientation of the intake grille. Align the logo on the panel according to the wishes of the customer as shown in the diagram to the left. (The position of the grille can be changed.)
 - ① Refrigerant piping of the main unit
 - ② Drain piping of the main unit
 - ③ Initial position of the corner panel (logo attached)
 - * Installation in any position is possible.
 - ④ Initial position of the levers on the intake grille
 - * Although the clips can be installed in any of 4 positions, the configuration shown here is recommended. (It is not necessary to remove the intake grille when maintenance is performed on the electric component box of the main unit.)
 - ⑤ Receiver (Only PLP-6BALM, PLP-6BALME Panel)
 - ⑥ i-see sensor (PLP-6BAE, PLP-6BAMDE, PLP-6BALME panel)

9.6. Installation of i-see sensor corner panel (Fig. 9-10)

For PLP-6BAE, PLP-6BAMDE, PLP-6BALME panel

- Take the lead wires CN4Y (white) and CN6Y (red) of the i-see sensor corner panel ⑨ from the side of the electrical box on the unit and make sure to connect them to the connector of the controller board.
- Lead wires of the i-see sensor corner panel ⑨ should be fixed at the rib of the grille with the fastener ④ so that there is no slack.
- Lead wires should be held together with the lead wires of the unit and fixed with 2 of the fastener ④ so that there is no slack.
- Put the cover back on the electrical box with 3 screws.
 - * Make sure wires are not caught in the cover of electric box. If they are caught, they will be cut.
- Adverse procedure of "9.2. Preparing to attach the grille" will be taken for installing the i-see sensor corner panel.
 - * The i-see sensor corner panel should be fixed onto the grille ① with screw ⑥.

9. Installing the grille

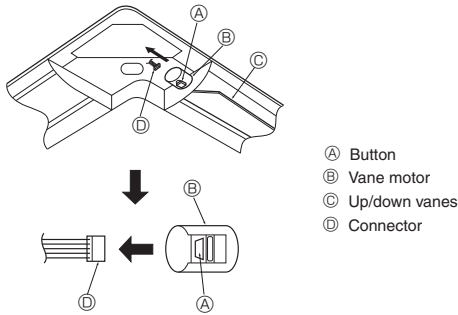

Fig. 9-11

9.7. Locking the up/down airflow direction (Fig. 9-11)

The vanes of the unit can be set and locked in up or down orientations depending upon the environment of use.

- Set according to the preference of the customer.
 - The operation of the fixed up/down vanes and all automatic controls cannot be performed using the remote controller. In addition, the actual position of the vanes may differ from the position indicated on the remote controller.
- ① Turn off the main power switch.
Injuries or an electrical shock may occur while the fan of the unit is rotating.
 - ② Disconnect the connector for the vane motor of the vent that you want to lock.
(While pressing the button, remove the connector in the direction indicated by the arrow as shown in the diagram.) After removing the connector, insulate it with tape. It also can be set by remote controller. Refer to 6.3.3.

9.8. Check

- Make sure that there is no gap between the unit and the grille, or between the grille and the surface of the ceiling. If there is any gap between the unit and the grille, or between the grille and the surface of the ceiling, it may cause dew to collect.
- Make sure that the wires have been securely connected.
- For PLP-6BAE, PLP-6BAMDE, PLP-6BALME, check the rotating movement of the i-see sensor. If the i-see sensor does not rotate, review the procedure in "9.6. Installation of i-see sensor corner panel".

10. Easy maintenance function (For PUHZ-(H)RP application only)

Display example (Comp discharge temperature 64°C)

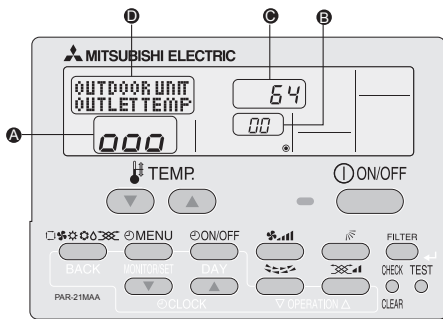

By using the maintenance mode, you can display many types of maintenance data on the remote controller such as the heat exchanger temperature and compressor current consumption for the indoor and outdoor units.

This function can be used whether the air conditioner is operating or not. During air conditioner operation, data can be checked during either normal operation or maintenance mode stable operation.

* This function cannot be used during the test run.

* The availability of this function depends on the connecting outdoor unit. Refer to the brochures.

Maintenance mode operation procedures

(1) Press the **TEST** button for 3 seconds to activate the maintenance mode. Display **A** MAINTENANCE

(2) Press the **TEMP.** **▼** **▲** buttons to set the refrigerant address. Display **B** 00 ↔ 01 15

(3) Select the data you want to display.

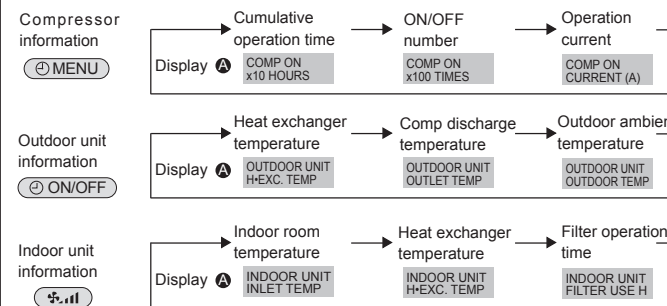

(4) Press the **FILTER** button.

(5) The data is displayed in **●**. (Airflow temperature display example)
Display **●** **64**
Blinking
Waiting for response
Approx. 10 sec.
64°C

* Repeat steps (2) to (5) to check another data.

(6) Press the **TEST** button for 3 seconds or press the **ON/OFF** button to deactivate the maintenance mode.

Stable operation

Using the maintenance mode, the operation frequency can be fixed and the operation can be stabilized. If the air conditioner is stopped, use the following procedure to start this operation.

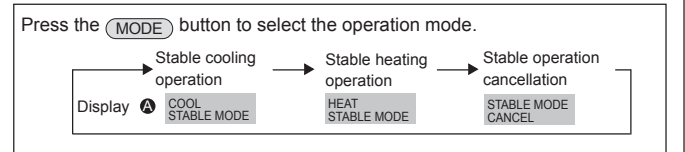

Press the **FILTER** button.

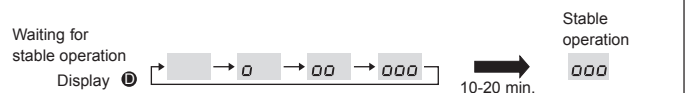

* You can check the data using steps (3) to (5) of the maintenance mode operation procedures while waiting for the stable operation.

This product is designed and intended for use in the residential,
commercial and light-industrial environment.

The product at hand is
based on the following
EU regulations:

- Low Voltage Directive 2006/95/EC
- Electromagnetic Compatibility Directive
2004/108/EC
- Machinery Directive 2006/42/EC
- Energy-related Products Directive
2009/125/EC *
- * Only RP35/50/60/71/100
- RoHs Directive 2011/65/EU

Please be sure to put the contact address/telephone number on
this manual before handing it to the customer.

MITSUBISHI ELECTRIC CORPORATION

HEAD OFFICE: TOKYO BLDG., 2-7-3, MARUNOUCHI, CHIYODA-KU, TOKYO 100-8310, JAPAN
Authorized representative in EU: MITSUBISHI ELECTRIC EUROPE B.V.

HARMAN HOUSE, 1 GEORGE STREET, UXBRIDGE, MIDDLESEX UB8 1QQ, U.K.