

Air-Conditioners PSA-RP·KA

INSTALLATION MANUAL

For safe and correct use, read this manual and the outdoor unit installation manual thoroughly before installing the air-conditioner unit.

FOR INSTALLER

INSTALLATIONSHANDBUCH

Aus Sicherheitsgründen und zur richtigen Anwendung vor Installation der Klimaanlage die vorliegende Bedienungsanleitung und das Installationshandbuch gründlich durchlesen.

FÜR INSTALLATEURE

MANUEL D'INSTALLATION

Avant d'installer le climatiseur, lire attentivement ce manuel, ainsi que le manuel d'installation de l'appareil extérieur pour une utilisation sûre et correcte.

POUR L'INSTALLATEUR

INSTALLATIEHANDLEIDING

Lees deze handleiding en de installatiehandleiding van het buitenapparaat zorgvuldig door voordat u met het installeren van de airconditioner begint.

VOOR DE INSTALLATEUR

MANUAL DE INSTALACIÓN

Para un uso seguro y correcto, lea detalladamente este manual de instalación antes de montar la unidad de aire acondicionado.

PARA EL INSTALADOR

MANUALE DI INSTALLAZIONE

Per un uso sicuro e corretto, prima di installare il condizionatore d'aria leggere attentamente il presente manuale ed il manuale d'installazione dell'unità esterna.

PER L'INSTALLATORE

ΕΓΧΕΙΡΙΔΙΟ ΟΔΗΓΙΩΝ ΕΓΚΑΤΑΣΤΑΣΗΣ

ΓΙΑ ΑΥΤΟΝ ΠΟΥ ΚΑΝΕΙ ΤΗΝ ΕΓΚΑΤΑΣΤΑΣΗ

Για σωστή και ασφαλή χρήση, διαβάστε προσεκτικά αυτό το εγχειρίδιο, καθώς και το εγχειρίδιο εγκατάστασης της εξωτερικής μονάδας, πριν από την εγκατάσταση της μονάδας κλιματιστικού.

MANUAL DE INSTALAÇÃO

Para uma utilização segura e correcta, leia atentamente este manual e o manual de instalação da unidade exterior antes de instalar o aparelho de ar condicionado.

PARA O INSTALADOR

INSTALLATIONSMANUAL

Læs af sikkerhedshensyn denne manual samt manualen til installation af udendørsenheden grundigt, før du installerer klimaanlægget.

TIL INSTALLATØREN

INSTALLATIONSMANUAL

Läs bruksanvisningen och utomhusenhetens installationshandbok noga innan luftkonditioneringen installeras så att den används på ett säkert och korrekt sätt.

FÖR INSTALLATÖREN

MONTAJ ELKİTABI

Emniyetli ve doğru kullanım için, klima cihazını monte etmeden önce bu kılavuzu ve iç ünite montaj kılavuzunu tamamıyla okuyun.

MONTÖR İÇİN

РУКОВОДСТВО ПО УСТАНОВКЕ

Для обеспечения безопасной и надлежащей эксплуатации внимательно прочтите данное руководство и руководство по установке наружного прибора перед установкой кондиционера.

ДЛЯ УСТАНОВИТЕЛЯ**English****Deutsch****Français****Nederlands****Español****Italiano****Ελληνικά****Português****Dansk****Svenska****Türkçe****Русский**

Contents

1. Safety precautions.....	2	5. Drainage piping work.....	6
2. Installation location.....	3	6. Electrical work.....	7
3. Installing the indoor unit.....	3	7. Test run.....	10
4. Installing the refrigerant piping.....	4	8. Easy maintenance function.....	12

1. Safety precautions

- ▶ Before installing the unit, make sure you read all the “Safety precautions”.
- ▶ Please report to your supply authority or obtain their consent before connecting this equipment to the power supply system.

⚠ Warning:
Describes precautions that must be observed to prevent danger of injury or death to the user.

⚠ Caution:
Describes precautions that must be observed to prevent damage to the unit.

- ⚠ Warning:**
- Ask a dealer or an authorized technician to install the unit.
 - For installation work, follow the instructions in the Installation Manual and use tools and pipe components specifically made for use with refrigerant specified in the outdoor unit installation manual.
 - The unit must be installed according to the instructions in order to minimize the risk of damage from earthquakes, typhoons, or strong winds. An incorrectly installed unit may fall down and cause damage or injuries.
 - The unit must be securely installed on a structure that can sustain its weight.
 - If the air conditioner is installed in a small room, measures must be taken to prevent the refrigerant concentration in the room from exceeding the safety limit in the event of refrigerant leakage. Should the refrigerant leak and cause the concentration limit to be exceeded, hazards due to lack of oxygen in the room may result.
 - Ventilate the room if refrigerant leaks during operation. If refrigerant comes into contact with a flame, poisonous gases will be released.
 - All electric work must be performed by a qualified technician according to local regulations and the instructions given in this manual.
 - Use only specified cables for wiring. The wiring connections must be made securely with no tension applied on the terminal connections. Also, never

After installation work has been completed, explain the “Safety Precautions,” use, and maintenance of the unit to the customer according to the information in the Operation Manual and perform the test run to ensure normal operation. Both the Installation Manual and Operation Manual must be given to the user for keeping. These manuals must be passed on to subsequent users.

⚡ : Indicates a part which must be grounded.

⚠ Warning:
Carefully read the labels affixed to the main unit.

- splice the cables for wiring (unless otherwise indicated in this document). Failure to observe these instructions may result in overheating or a fire.
- The terminal block cover panel of the unit must be firmly attached.
- Use only accessories authorized by Mitsubishi Electric and ask a dealer or an authorized technician to install them.
- The user should never attempt to repair the unit or transfer it to another location.
- After installation has been completed, check for refrigerant leaks. If refrigerant leaks into the room and comes into contact with the flame of a heater or portable cooking range, poisonous gases will be released.
- When installing or relocating, or servicing the air conditioner, use only the specified refrigerant (R410A) to charge the refrigerant lines. Do not mix it with any other refrigerant and do not allow air to remain in the lines. If air is mixed with the refrigerant, then it can be the cause of abnormal high pressure in the refrigerant line, and may result in an explosion and other hazards. The use of any refrigerant other than that specified for the system will cause mechanical failure or system malfunction or unit breakdown. In the worst case, this could lead to a serious impediment to securing product safety.

1.1. Before installation (Environment)

- ⚠ Caution:**
- Do not use the unit in an unusual environment. If the air conditioner is installed in areas exposed to steam, volatile oil (including machine oil), or sulfuric gas, areas exposed to high salt content such as the seaside, the performance can be significantly reduced and the internal parts can be damaged.
 - Do not install the unit where combustible gases may leak, be produced, flow, or accumulate. If combustible gas accumulates around the unit, fire or explosion may result.
 - Do not keep food, plants, caged pets, artwork, or precision instruments in the direct airflow of the indoor unit or too close to the unit, as these items can be damaged by temperature changes or dripping water.

- When the room humidity exceeds 80% or when the drainpipe is clogged, water may drip from the indoor unit. Do not install the indoor unit where such dripping can cause damage.
- When installing the unit in a hospital or communications office, be prepared for noise and electronic interference. Inverters, home appliances, high-frequency medical equipment, and radio communications equipment can cause the air conditioner to malfunction or breakdown. The air conditioner may also affect medical equipment, disturbing medical care, and communications equipment, harming the screen display quality.

1.2. Before installation or relocation

- ⚠ Caution:**
- Be extremely careful when transporting the units. Two or more persons are needed to handle the unit, as it weighs 20 kg or more. Do not grasp the packaging bands. Wear protective gloves as you can injure your hands on the fins or other parts.
 - Be sure to safely dispose of the packaging materials. Packaging materials, such as nails and other metal or wooden parts may cause stabs or other injuries.

- Thermal insulation of the refrigerant pipe is necessary to prevent condensation. If the refrigerant pipe is not properly insulated, condensation will be formed.
- Place thermal insulation on the pipes to prevent condensation. If the drainpipe is installed incorrectly, water leakage and damage to the ceiling, floor, furniture, or other possessions may result.
- Do not clean the air conditioner unit with water. Electric shock may result.
- Tighten all flare nuts to specification using a torque wrench. If tightened too much, the flare nut can break after an extended period.

1.3. Before electric work

- ⚠ Caution:**
- Be sure to install circuit breakers. If not installed, electric shock may result.
 - For the power lines, use standard cables of sufficient capacity. Otherwise, a short circuit, overheating, or fire may result.
 - When installing the power lines, do not apply tension to the cables.

- Be sure to ground the unit. If the unit is not properly grounded, electric shock may result.
- Use circuit breakers (ground fault interrupter, isolating switch (+B fuse), and molded case circuit breaker) with the specified capacity. If the circuit breaker capacity is larger than the specified capacity, breakdown or fire may result.

1.4. Before starting the test run

- ⚠ Caution:**
- Turn on the main power switch more than 12 hours before starting operation. Starting operation just after turning on the power switch can severely damage the internal parts.
 - Before starting operation, check that all panels, guards and other protective parts are correctly installed. Rotating, hot, or high voltage parts can cause injuries.

- Do not operate the air conditioner without the air filter set in place. If the air filter is not installed, dust may accumulate and breakdown may result.
- Do not touch any switch with wet hands. Electric shock may result.
- Do not touch the refrigerant pipes with bare hands during operation.
- After stopping operation, be sure to wait at least five minutes before turning off the main power switch. Otherwise, water leakage or breakdown may result.

2. Installation location

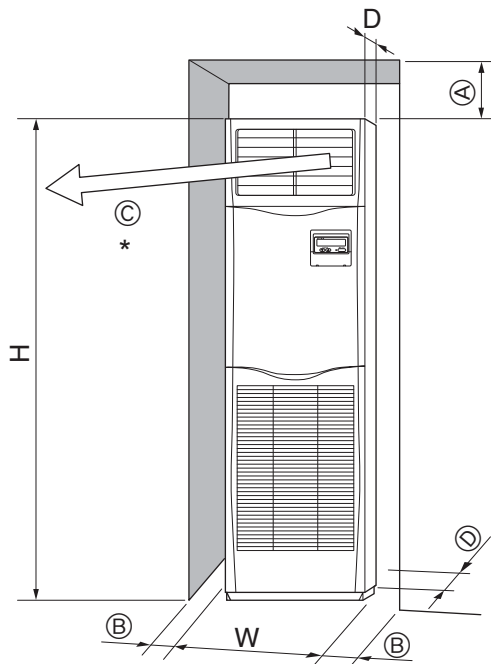

Fig. 2-1

2.1. Outline dimensions (Indoor unit) (Fig. 2-1)

Select a proper position allowing the following clearances for installation and maintenance.

Models	W	D	H	A	B	C	D
71,100,125,140	600	360	1900	300	Min. 100	Min. 1000	Min. 5

(mm)

* Do not place any objects within 1000 mm of the air outlet.

Warning:

Mount the indoor unit on a ceiling strong enough to withstand the weight of the unit.

3. Installing the indoor unit

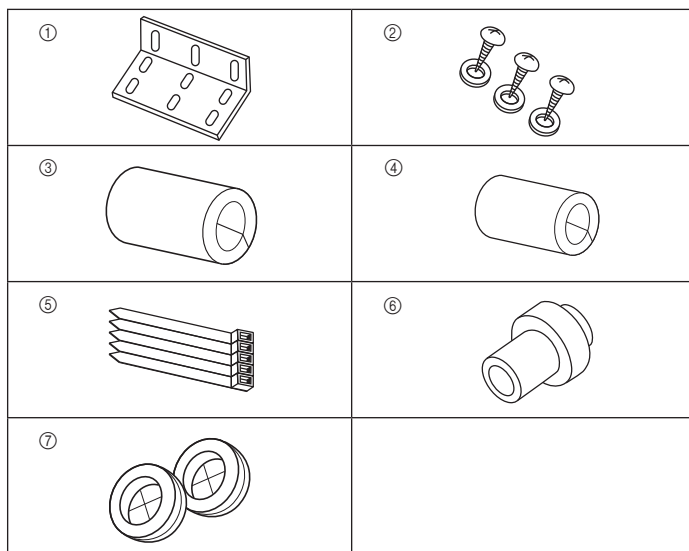

Fig. 3-1

3.1. Check the indoor unit accessories

The indoor unit is supplied with the following spare parts and accessories.

Part number	Accessory name	Q'ty	Setting location
①	Tip-over prevention bracket	1	The top surface of the unit.
②	Tapping screws (with washer)	3	Inside the air intake grill.
③	Gas pipe insulation (large)	1	
④	Liquid pipe insulation (small)	1	
⑤	Band	5	
⑥	Drain socket	1	
⑦	Bushing (for the wire hole)	2	

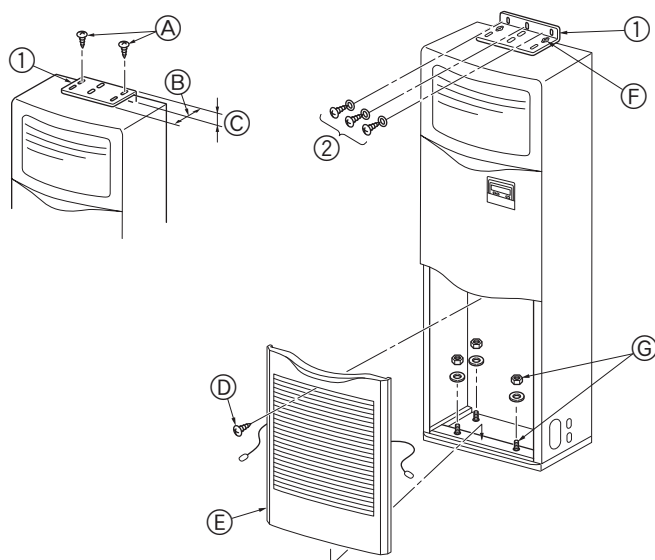

Fig. 3-2

3.2. Tip-over prevention bracket (Fig. 3-2)

To prevent the unit from tipping over attach the tip-over prevention bracket to the wall.

- ① Tip-over prevention bracket
 - Ⓐ Tapping screws 4 × 10 (with washer)
 - Ⓑ The long edge of the unit
 - Ⓒ The short edge of the unit

The tip-over prevention bracket ① is set on the top surface of the unit. Remove the tapping screws ②, and then reinstall the bracket, as shown in the illustration. For the proper installation distances, see Fig. 3-3.

- ② Screw
 - Ⓓ Remove the screw ⑩ and then pull the grill forward to remove it.

Example of a tip-over prevention bracket

If the wall or floor is made of a material other than wood, use a suitable device such as a commercially available concrete anchor to hold the unit in place.

- ② 4 × 25 tapping screws
 - Ⓕ Hold the bracket in place with the tapping screws ②.
 - Ⓖ The bottom of the unit can be held in place by four anchor bolts which can be obtained locally.

3. Installing the indoor unit

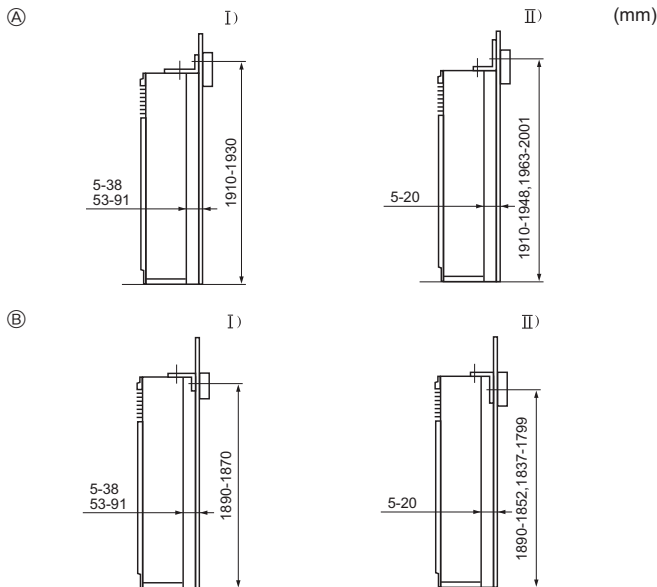

Fig. 3-3

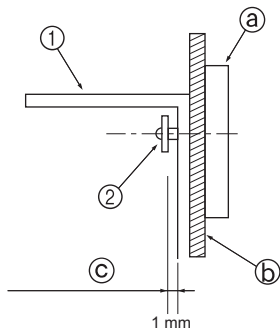

Fig. 3-4

3.3. Mounting the tip-over prevention bracket (Fig. 3-3)

- Select one of the following mounting methods, depending on the height of the frieze inside the wall above the floor.
- In the case of a light steel bed, a frieze is generally not used, so the bracket should be mounted to one of the supports or pillars (obtain the screws locally).
- If the air outlet duct is to be attached to the unit ceiling panel, make sure that the long edge of the bracket is placed against the wall. This will ensure that the bracket does not cover the knockout holes in the unit ceiling panel or the screw holes for attaching the air outlet duct.

- Ⓐ The bracket faces up
- Ⓑ The bracket faces down
 - I) The short edge of the bracket is against the wall
 - II) The long edge of the bracket is against the wall

- The distance between the unit and the wall can be varied.
- The vertical dimension shown is the distance from the floor to the bracket mounting screws (the frieze center is within these limits).

- First, mount the bracket on the wall and then tighten the screw so that the bracket can slide up and down. (Fig. 3-4)

- ① Tip-over prevention bracket
- ② Tapping screw
- Ⓐ Frieze
- ⓑ Wall surface material
- ⓒ Gap of about 1 mm

Floor mounting

Remove the air intake grill, open the floor mounting knockout holes in the base and fix the anchor bolts to the floor.

4. Installing the refrigerant piping

4.1. Precautions

4.1.1. For devices that use R410A refrigerant

- Use ester oil, ether oil, alkylbenzene oil (small amount) as the refrigeration oil applied to the flared sections.
- Use C1220 copper phosphorus, for copper and copper alloy seamless pipes, to connect the refrigerant pipes. Use refrigerant pipes with the thicknesses specified in the table to the below. Make sure the insides of the pipes are clean and do not contain any harmful contaminants such as sulfuric compounds, oxidants, debris, or dust.

⚠ Warning:

When installing or relocating, or servicing the air conditioner, use only the specified refrigerant (R410A) to charge the refrigerant lines. Do not mix it with any other refrigerant and do not allow air to remain in the lines.

If air is mixed with the refrigerant, then it can be the cause of abnormal high pressure in the refrigerant line, and may result in an explosion and other hazards. The use of any refrigerant other than that specified for the system will cause mechanical failure or system malfunction or unit breakdown. In the worst case, this could lead to a serious impediment to securing product safety.

Liquid pipe	ø9.52 thickness 0.8 mm
Gas pipe	ø15.88 thickness 1.0 mm

- Do not use pipes thinner than those specified above.

4. Installing the refrigerant piping

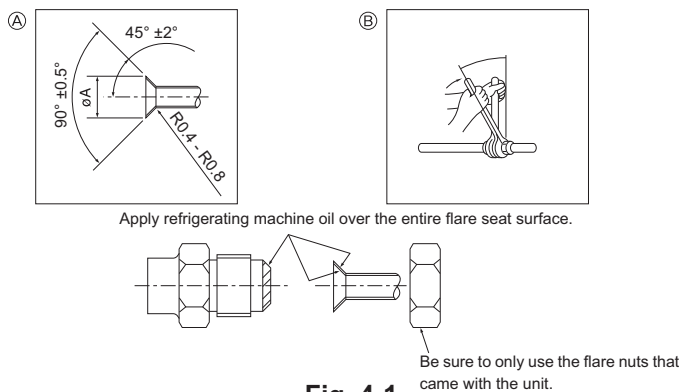

Fig. 4-1

(A) Flare cutting dimensions

Copper pipe O.D. (mm)	Flare dimensions øA dimensions (mm)
ø9.52	12.8 - 13.2
ø15.88	19.3 - 19.7

(B) Flare nut tightening torque

Copper pipe O.D. (mm)	Tightening torque (N·m)	Tightening angle (Guideline)
ø9.52	34 - 42	60° - 90°
ø15.88	66 - 82	30° - 60°

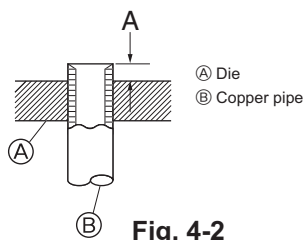

Fig. 4-2

Copper pipe O.D. (mm)	A (mm)
	Flare tool for R410A Clutch type
ø9.52 (3/8")	0 - 0.5
ø15.88 (5/8")	0 - 0.5

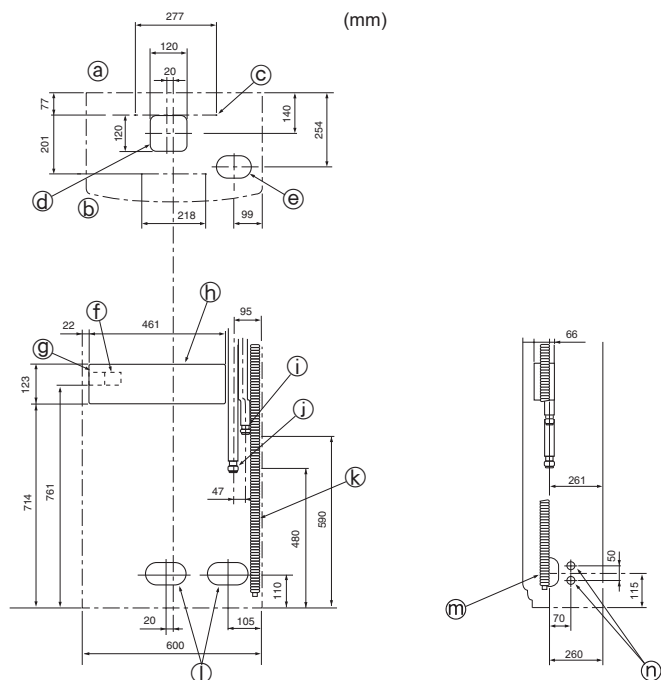

Fig. 4-3

4.2. Indoor unit (Fig. 4-1)

- When commercially available copper pipes are used, wrap liquid and gas pipes with commercially available insulation materials (heat-resistant to 100 °C or more, thickness of 12 mm or more).
- The indoor parts of the drain pipe should be wrapped with polyethylene foam insulation materials (specific gravity of 0.03, thickness of 9 mm or more).
- Apply thin layer of refrigerant oil to pipe and joint seating surface before tightening flare nut.
- Use two wrenches to tighten piping connections.
- Use leak detector or soapy water to check for gas leaks after connections are completed.
- Use refrigerant piping insulation provided to insulate indoor unit connections. Insulate carefully following shown below.
- Use correct flare nuts meeting the pipe size of the outdoor unit.

Available pipe size

Liquid side	ø9.52
Gas side	ø15.88

⚠ Warning:

When installing the unit, securely connect the refrigerant pipes before starting the compressor.

4.3. Refrigerant and drainage pipe locations (Fig. 4-3)

Where knockout holes are indicated, use a saw blade to cut along the groove.

Do not cut the hole larger than the indicated groove.

- Ⓐ Rear surface
- Ⓑ Front surface
- Ⓒ Knockout hole for mounting: 4-10 mm diameter hole
- Ⓓ * knockout hole for connections under the unit
- Ⓔ 120 × 120 knockout hole for connections under the unit
- Ⓕ Indoor/outdoor unit connecting terminals
- Ⓖ Power supply terminals
- Ⓗ Electrical equipment box
- Ⓘ Liquid pipe
- Ⓛ Gas pipe
- Ⓚ Drain pipe outlet diameter ø26 <PVC pipe VP20 connection>
- Ⓜ 140 × 80
Knockout hole for refrigerant and drainage piping and electrical wiring
- Ⓨ 90 × 60
Knockout hole for refrigerant and drainage piping
- Ⓩ 27 mm diameter knockout hole for electrical wiring (there is a similar hole on the left side)

4. Installing the refrigerant piping

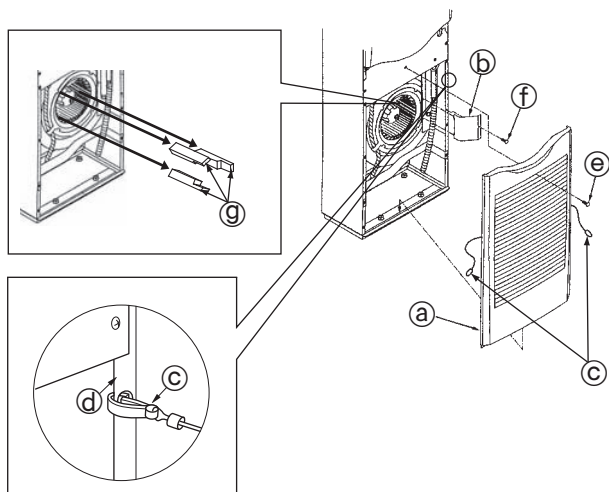

Fig. 4-4

Refrigerant piping connection (Fig. 4-4)

1. Remove the screw from the air intake grill handle and then remove the air intake grill by pulling it up and forward.
2. Remove the tapping screw that holds the pipe support in place and then remove the pipe support.
3. Remove the cushions.
 - Be sure to remove the three cushions from the fan before operating the indoor unit.
 - After finishing this work, always reassemble the unit.
 - When reassembling, hook the air intake grill hangers (c) onto the holes in the sides of the panels.

- Ⓐ Air intake grill
- Ⓑ Pipe support
- Ⓒ Hanger
- Ⓓ Side panel
- Ⓔ Screw
- Ⓕ 4 × 10 tapping screw
- Ⓖ Cushion

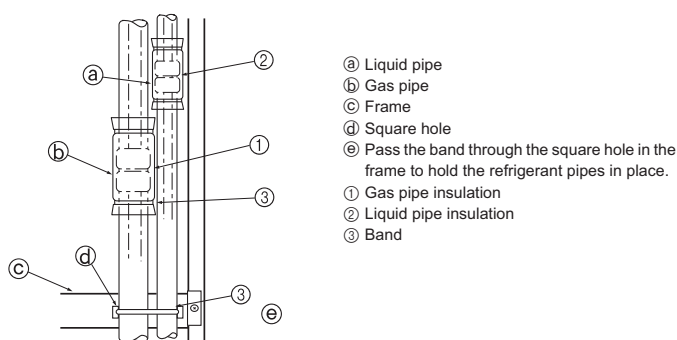

Fig. 4-5

Insulate flare joints ① and ② of the gas and refrigerant pipes completely. If any part of the joints are exposed, condensation can drip down. (Fig. 4-5)

- Fasten the gas pipe insulation ① and the liquid pipe insulation ② at both ends so that they will not slip and align with one another.
- After the insulation is installed, use a band ③ to fasten the refrigerant pipe to the frame (below the pipe joint section). This will prevent the refrigerant pipe from lifting up off of the frame. (When the refrigerant pipe is off of the frame, the grille cannot be installed.)
- After connecting the refrigerant piping to the indoor unit, be sure to test the pipe connections for gas leakage with nitrogen gas. (Check that there is no refrigerant leakage from the refrigerant piping to the indoor unit.) Conduct the airtightness test before connecting the outdoor unit stop valve and the refrigerant pipe. If the test is conducted after the valve and pipe are connected, gas, which is used for checking the airtightness, will leak from the stop valve and flow into the outdoor unit, resulting in abnormal operation.

5. Drainage piping work

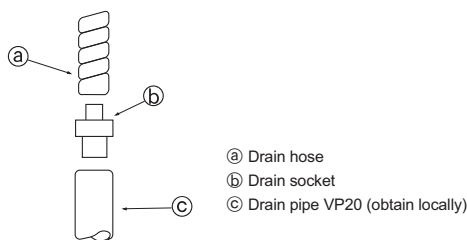

Fig. 5-1

5.1. Drainage Piping Work (Fig. 5-1)

- Install the drain pipe so that it slopes downward (1/100 or more).
- Use VP20 (O.D. ø26 PVC TUBE) for the drain pipes.
- The drain hose can be cut with a knife to match on-site requirements.
- When connecting to the VP20, use the accessory drain socket (b). Securely fasten the socket to the pipe with vinyl chloride type adhesive so that it doesn't leak.
- Do not insert the drain pipe directly into a location where sulfur-containing gas is likely to be generated (i.e. a sewer).
- Make sure that no water leaks from the drain pipe joint.
- If the drain pipe passes through an indoor area, wrap commercially available insulation (polyethylene foam of specific gravity 0.03 with a thickness of 9 mm or more) around it and cover the surface with tape. This will prevent air from entering and condensation from forming.

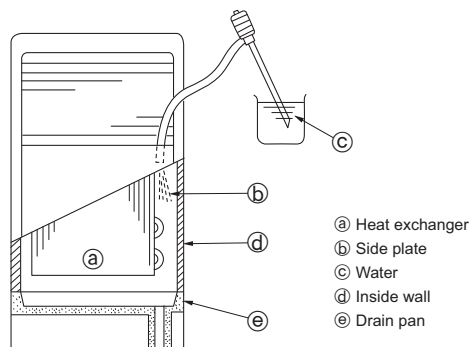

Fig. 5-2

5.2. Drainage check (Fig. 5-2)

- After installing the pipes, make sure that the waste water is being drained out properly and that water is not leaking from the joints (also perform these checks if installation is done during the heating season).
- Insert a water supply pump from the right side of the air outflow port and pump about 1L of water into the unit.
 - * Pump gently, toward the heat exchanger side plate or the unit inside wall.
 - * Always pump from the right side of the air outflow port.
 - * If the unit has a heater, the heater will be attached to the front surface of the heat exchanger, make sure that water does not get onto the heater.

6. Electrical work

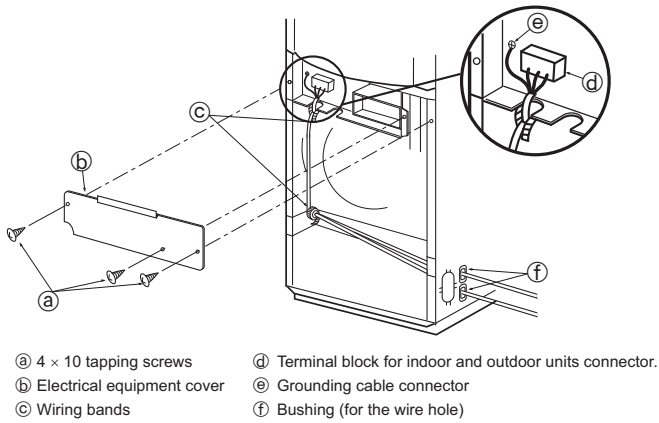

Fig. 6-1

6.1. Electric wiring (Fig. 6-1)

1. Remove the tapping screws (a) and then remove the electrical equipment cover (b).
2. Connect the electric wires securely to the corresponding terminals.
3. Fasten the wires (d) with the bands (c).
 - Always ground the wiring (the ground wire diameter must be 1.6 mm or more).
 - If the wires contact the pipes, condensation may drip onto them. Make sure that the wires are properly routed.
 - Fasten the power source wiring to the control box using the buffer bushing for tensile force (PG connection or the like)
 - After finishing this work, always reassemble the unit.
 - For instructions on how to reinstall the air intake grill, see page 6.

⚠ Warning:

Never splice the power cable or the indoor-outdoor connection cable, otherwise it may result in a smoke, a fire or communication failure.

6.1.1. Indoor unit power supplied from outdoor unit

The following connection patterns are available.

The outdoor unit power supply patterns vary on models.

1:1 System

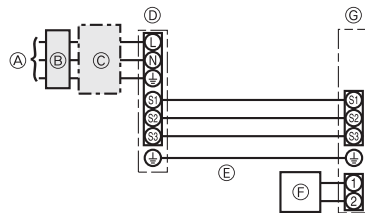

- (A) Outdoor unit power supply
- (B) Earth leakage breaker
- (C) Wiring circuit breaker or isolating switch
- (D) Outdoor unit
- (E) Indoor unit/outdoor unit connecting cords
- (F) Remote controller
- (G) Indoor unit

* Affix a label A that is included with the manuals near each wiring diagram for the indoor and outdoor units.

Simultaneous twin/triple/four system

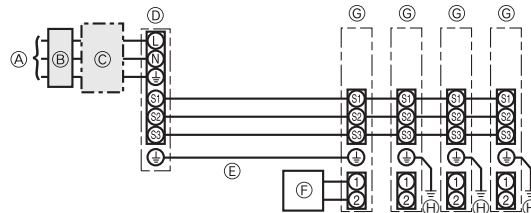

- (A) Outdoor unit power supply
- (B) Earth leakage breaker
- (C) Wiring circuit breaker or isolating switch
- (D) Outdoor unit
- (E) Indoor unit/outdoor unit connecting cords
- (F) Remote controller
- (G) Indoor unit
- (H) Indoor unit earth

* Affix a label A that is included with the manuals near each wiring diagram for the indoor and outdoor units.

Wiring Wire No. × size (mm ²)	Indoor unit-Outdoor unit	*1	3 × 1.5 (polar)
	Indoor unit-Outdoor unit earth	*1	1 × Min. 1.5
	Indoor unit earth		1 × Min. 1.5
	Remote controller-Indoor unit	*2	2 × 0.3 (Non-polar)
Circuit rating	Indoor unit (Heater) L-N	*3	—
	Indoor unit-Outdoor unit S1-S2	*3	AC 230 V
	Indoor unit-Outdoor unit S2-S3	*3	DC24 V
	Remote controller-Indoor unit	*3	DC12 V

*1. <For 25-140 outdoor unit application>

Max. 45 m

If 2.5 mm² used, Max. 50 m

If 2.5 mm² used and S3 separated, Max. 80 m

<For 200/250 outdoor unit application>

Max. 18 m

If 2.5 mm² used, Max. 30 m

If 4 mm² used and S3 separated, Max. 50 m

If 6 mm² used and S3 separated, Max. 80 m

*2. The 10 m wire is attached in the remote controller accessory. Max. 500 m

*3. The figures are NOT always against the ground.

S3 terminal has DC 24 V against S2 terminal. However between S3 and S1, these terminals are not electrically insulated by the transformer or other device.

Notes: 1. Wiring size must comply with the applicable local and national code.

2. Power supply cords and indoor unit/outdoor unit connecting cords shall not be lighter than polychloroprene sheathed flexible cord. (Design 60245 IEC 57)

3. Install an earth longer than other cables.

6. Electrical work

6.1.2. Separate indoor unit/outdoor unit power supplies (For PUHZ application only)

The following connection patterns are available.

The outdoor unit power supply patterns vary on models.

1:1 System

* The optional wiring replacement kit is required.

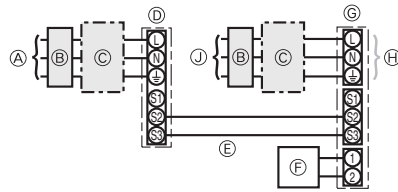

- Ⓐ Outdoor unit power supply
- Ⓑ Earth leakage breaker
- Ⓒ Wiring circuit breaker or isolating switch
- Ⓓ Outdoor unit
- Ⓔ Indoor unit/outdoor unit connecting cords
- Ⓕ Remote controller
- Ⓖ Indoor unit
- Ⓗ Option
- Ⓙ Indoor unit power supply

* Affix a label B that is included with the manuals near each wiring diagram for the indoor and outdoor units.

Simultaneous twin/triple/four system

* The optional wiring replacement kits are required.

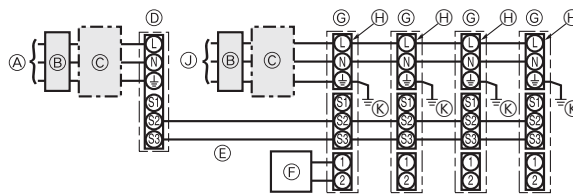

- Ⓐ Outdoor unit power supply
- Ⓑ Earth leakage breaker
- Ⓒ Wiring circuit breaker or isolating switch
- Ⓓ Outdoor unit
- Ⓔ Indoor unit/outdoor unit connecting cords
- Ⓕ Remote controller
- Ⓖ Indoor unit
- Ⓗ Option
- Ⓙ Indoor unit power supply
- Ⓚ Indoor unit earth

* Affix a label B that is included with the manuals near each wiring diagram for the indoor and outdoor units.

If the indoor and outdoor units have separate power supplies, refer to the table at the below. If the optional wiring replacement kit is used, change the indoor unit electrical box wiring referring to the figure in the right and the DIP switch settings of the outdoor unit control board.

	Indoor unit specifications								
Indoor power supply terminal kit (option)	Required								
Indoor unit electrical box connector connection change	Required								
Label affixed near each wiring diagram for the indoor and outdoor units	Required								
Outdoor unit DIP switch settings (when using separate indoor unit/outdoor unit power supplies only)	<table border="1" style="display: inline-table;"> <tr> <td>ON</td> <td></td> <td></td> <td>3</td> </tr> <tr> <td>OFF</td> <td>1</td> <td>2</td> <td></td> </tr> </table> (SW8)	ON			3	OFF	1	2	
ON			3						
OFF	1	2							

* There are three types of labels (labels A, B, and C). Affix the appropriate labels to the units according to the wiring method.

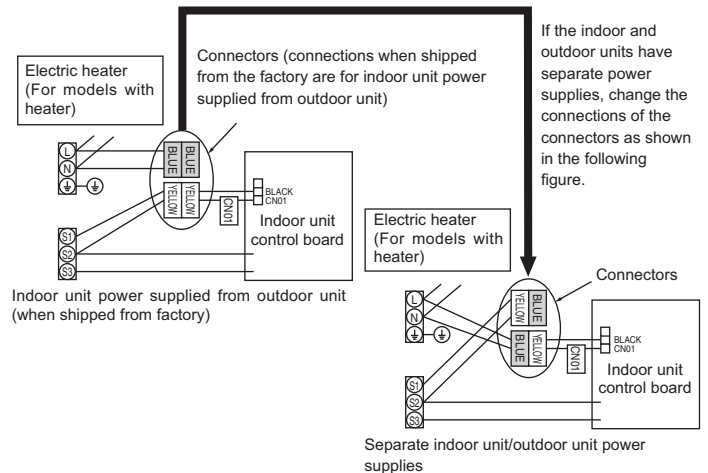

Indoor unit power supply		~N (single), 50 Hz, 230 V
Indoor unit input capacity Main switch (Breaker)	*1	16 A
Wiring Wire No. x size (mm ²)	Indoor unit power supply	2 × Min. 1.5
	Indoor unit power supply earth	1 × Min. 1.5
	Indoor unit-Outdoor unit	*2 2 × Min. 0.3
	Indoor unit-Outdoor unit earth	-
	Remote controller-Indoor unit	*3 2 × 0.3 (Non-polar)
Circuit rating	Indoor unit L-N	*4 AC 230 V
	Indoor unit-Outdoor unit S1-S2	*4 -
	Indoor unit-Outdoor unit S2-S3	*4 DC24 V
	Remote controller-Indoor unit	*4 DC12 V

*1. A breaker with at least 3 mm contact separation in each pole shall be provided. Use non-fuse breaker (NF) or earth leakage breaker (NV).

*2. Max. 120 m

*3. The 10 m wire is attached in the remote controller accessory. Max. 500 m

*4. The figures are NOT always against the ground.

Notes: 1. Wiring size must comply with the applicable local and national code.

2. Power supply cords and indoor unit/outdoor unit connecting cords shall not be lighter than polychloroprene sheathed flexible cord. (Design 60245 IEC 57)

3. Install an earth longer than other cables.

6. Electrical work

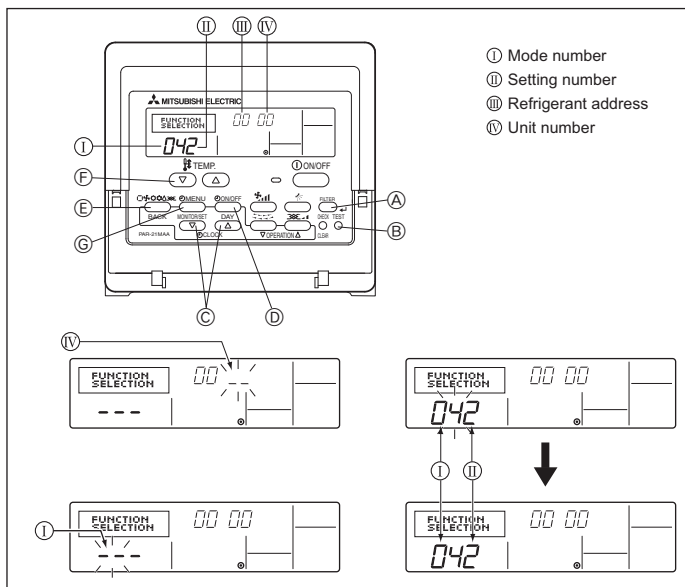

Fig. 6-2

6.2. Function settings

6.2.1. Function setting on the unit (Fig. 6-2)

Changing the power voltage setting

• Be sure to change the power voltage setting depending on the voltage used.

- ① Go to the function setting mode.
Switch OFF the remote controller.
Press the (A) and (B) buttons simultaneously and hold them for at least 2 seconds. FUNCTION will start to flash.
- ② Use the (C) button to set the refrigerant address (III) to 00.
- ③ Press (D) and [-] will start to flash in the unit number (IV) display.
- ④ Use the (C) button to set the unit number (IV) to 00.
- ⑤ Press the (E) MODE button to designate the refrigerant address/unit number. [-] will flash in the mode number (I) display momentarily.
- ⑥ Press the (F) buttons to set the mode number (I) to 04.
- ⑦ Press the (G) button and the current set setting number (II) will flash.
Use the (F) button to switch the setting number in response to the power supply voltage to be used.
Power supply voltage
240 V : setting number = 1
220 V, 230 V : setting number = 2
- ⑧ Press the MODE button (E) and mode and the setting number (I) and (II) will change to being on constantly and the contents of the setting can be confirmed.
- ⑨ Press the FILTER (A) and TEST RUN (B) buttons simultaneously for at least two seconds. The function selection screen will disappear momentarily and the air conditioner OFF display will appear.

6.2.2. Function setting on the remote controller

Refer to the indoor unit operation manual.

Function table

Select unit number 00

Mode	Settings	Mode no.	Setting no.	Initial setting	Setting
Power failure automatic recovery	Not available	01	1	*2	
	Available		2	*2	
Indoor temperature detecting	Indoor unit operating average	02	1	○	
	Set by indoor unit's remote controller		2		
	Remote controller's internal sensor		3	-	
LOSSNAY connectivity	Not Supported	03	1	○	
	Supported (indoor unit is not equipped with outdoor-air intake)		2		
	Supported (indoor unit is equipped with outdoor-air intake)		3		
Power voltage	240 V	04	1		
	220 V, 230 V		2	○	

Select unit numbers 01 to 03 or all units (AL [wired remote controller]/07 [wireless remote controller])

Mode	Settings	Mode no.	Setting no.	Initial setting	Setting
Filter sign	100 H	07	1		
	2500 Hr		2	○	
	No filter sign indicator		3		
Fan speed	Silent	08	1		
	Standard		2	○	
	-		3	-	

*1 When the power supply returns, the air conditioner will start 4 minutes later.

*2 Power failure automatic recovery initial setting depends on the connecting outdoor unit.

7. Test run

7.1. Before test run

- ▶ After completing installation and the wiring and piping of the indoor and outdoor units, check for refrigerant leakage, looseness in the power supply or control wiring, wrong polarity, and no disconnection of one phase in the supply.
- ▶ Use a 500-volt megohmmeter to check that the resistance between the power supply terminals and ground is at least 1.0 MΩ.

- ▶ Do not carry out this test on the control wiring (low voltage circuit) terminals.

⚠ Warning:

Do not use the air conditioner if the insulation resistance is less than 1.0 MΩ.
Insulation resistance

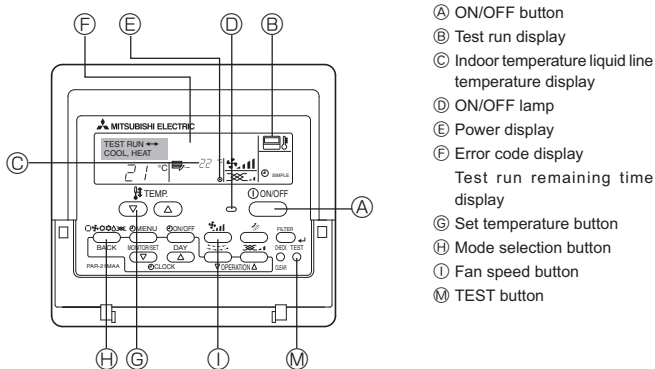

Fig. 7-1

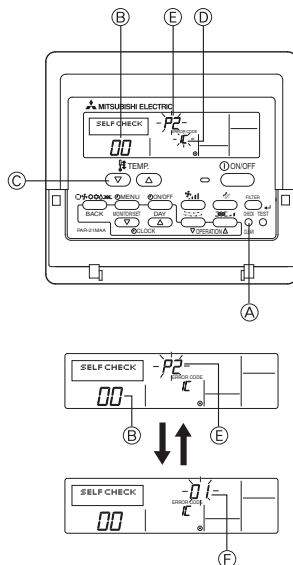

Fig. 7-2

7.2. Test run

The following 2 methods are available.

7.2.1. Using wired remote controller (Fig. 7-1)

- ① Turn on the power at least 12 hours before the test run.
- ② Press the [TEST] button twice. ⇒ "TEST RUN" liquid crystal display
- ③ Press the [Mode selection] button. ⇒ Make sure that wind is blown out.
- ④ Press the [Mode selection] button and switch to the cooling (or heating) mode. ⇒ Make sure that cold (or warm) wind is blown out.
- ⑤ Press the [Fan speed] button. ⇒ Make sure that the wind speed is switched.
- ⑥ Check operation of the outdoor unit fan.
- ⑦ Release test run by pressing the [ON/OFF] button. ⇒ Stop
- ⑧ Register a telephone number.

The telephone number of the repair shop, sales office, etc., to contact if an error occurs can be registered in the remote controller. The telephone number will be displayed when an error occurs. For registration procedures, refer to the operation manual for the indoor unit.

7.2.2. Using SW4 in outdoor unit

Refer to the outdoor unit installation manual.

7.3. Self-check (Fig. 7-2)

- ① Turn on the power.
- ② Press the [CHECK] button twice.
- ③ Set refrigerant address with [TEMP] button if system control is used.
- ④ Press the [ON/OFF] button to stop the self-check.

- A CHECK button
- B Refrigerant address
- C TEMP. button
- D IC: Indoor unit
- OC: Outdoor unit
- E Check code
- F Unit address

[Output pattern A] Errors detected by indoor unit

Check code	Symptom	Remark
P1	Intake sensor error	
P2	Pipe (TH2) sensor error	
P9	Pipe (TH5) sensor error	
E6, E7	Indoor/outdoor unit communication error	
P4	Drain sensor error	
P5	Drain pump error	
P6	Freezing/Overheating safeguard operation	
EE	Communication error between indoor and outdoor units	
P8	Pipe temperature error	
E4	Remote controller signal receiving error	
—	—	
—	—	
PL	Refrigerant circuit abnormal	
Fb	Indoor unit control system error (memory error, etc.)	
--	No corresponding	

7. Test run

[Output pattern B] Errors detected by unit other than indoor unit (outdoor unit, etc.)

Check code	Symptom	Remark
E9	Indoor/outdoor unit communication error (Transmitting error) (Outdoor unit)	For details, check the LED display of the outdoor controller board.
UP	Compressor overcurrent interruption	
U3, U4	Open/short of outdoor unit thermistors	
UF	Compressor overcurrent interruption (When compressor locked)	
U2	Abnormal high discharging temperature/49C worked/insufficient refrigerant	
U1, Ud	Abnormal high pressure (63H worked)/Overheating safeguard operation	
U5	Abnormal temperature of heat sink	
U8	Outdoor unit fan safeguard stop	
U6	Compressor overcurrent interruption/Abnormal of power module	
U7	Abnormality of super heat due to low discharge temperature	
U9, UH	Abnormality such as overvoltage or voltage shortage and abnormal synchronous signal to main circuit/Current sensor error	
-	-	
-	-	
Others	Other errors (Refer to the technical manual for the outdoor unit.)	

- On wired remote controller
Check code displayed in the LCD.

- If the unit cannot be operated properly after the above test run has been performed, refer to the following table to remove the cause.

Symptom		Cause
Wired remote controller	LED 1, 2 (PCB in outdoor unit)	
PLEASE WAIT	For about 2 minutes following power-on	After LED 1, 2 are lighted, LED 2 is turned off, then only LED 1 is lighted. (Correct operation)
PLEASE WAIT → Error code	After about 2 minutes has expired following power-on	Only LED 1 is lighted. → LED 1, 2 blink.
Display messages do not appear even when operation switch is turned ON (operation lamp does not light up).		Only LED 1 is lighted. → LED 1 blinks twice, LED 2 blinks once.
		<ul style="list-style-type: none"> • For about 2 minutes following power-on, operation of the remote controller is not possible due to system start-up. (Correct operation) • Connector for the outdoor unit's protection device is not connected. • Reverse or open phase wiring for the outdoor unit's power terminal block (L1, L2, L3) • Incorrect wiring between indoor and outdoor units (incorrect polarity of S1, S2, S3) • Remote controller wire short

Note:

Operation is not possible for about 30 seconds after cancellation of function selection. (Correct operation)

For description of each LED (LED1, 2, 3) provided on the indoor controller, refer to the following table.

LED 1 (power for microcomputer)	Indicates whether control power is supplied. Make sure that this LED is always lit.
LED 2 (power for remote controller)	Indicates whether power is supplied to the remote controller. This LED lights only in the case of the indoor unit which is connected to the outdoor unit refrigerant address "0".
LED 3 (communication between indoor and outdoor units)	Indicates state of communication between the indoor and outdoor units. Make sure that this LED is always blinking.

8. Easy maintenance function

Display example (Comp discharge temperature 64 °C)

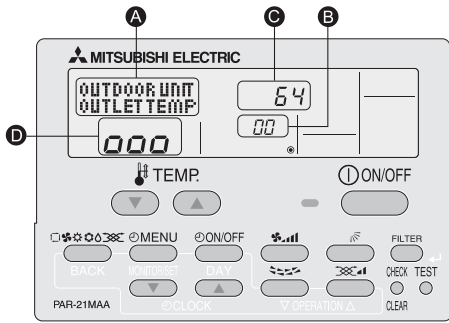

By using the maintenance mode, you can display many types of maintenance data on the remote controller such as the heat exchanger temperature and compressor current consumption for the indoor and outdoor units.

This function can be used whether the air conditioner is operating or not.

During air conditioner operation, data can be checked during either normal operation or maintenance mode stable operation.

* This function cannot be used during the test run.

* The availability of this function depends on the connecting outdoor unit. Refer to the brochures.

Maintenance mode operation procedures

(1) Press the **TEST** button for three seconds to activate the maintenance mode. Display **A** MAINTENANCE

(2) Press the TEMP. **▼** **▲** buttons to set the refrigerant address. Display **B** 00 ↔ 01 15

(3) Select the data you want to display.

Compressor information	→	Cumulative operation time	→	ON/OFF number	→	Operation current
MENU		Display A COMP ON x10 HOURS		COMP ON x100 TIMES		COMP ON CURRENT (A)
Outdoor unit information	→	Heat exchanger temperature	→	Comp discharge temperature	→	Outdoor ambient temperature
ON/OFF		Display A OUTDOOR UNIT H-EXC. TEMP		OUTDOOR UNIT OUTLET TEMP		OUTDOOR UNIT OUTDOOR TEMP
Indoor unit information	→	Indoor room temperature	→	Heat exchanger temperature	→	Filter operation time
INLET		Display A INDOOR UNIT INLET TEMP		INDOOR UNIT H-EXC. TEMP		INDOOR UNIT FILTER USE H

* The filter operation time displayed is the number of hours the filter has been used since the filter reset was performed.

(4) Press the **FILTER** button.

(5) The data is displayed in **C**. (Airflow temperature display example)

Display **C** Flashing Waiting for response → Approx. 10 sec. → 64 → 64 °C

* Repeat steps (2) to (5) to check another data.

(6) Press the **TEST** button for three seconds or press the **ON/OFF** button to deactivate the maintenance mode.

Stable operation
Using the maintenance mode, the operation frequency can be fixed and the operation can be stabilized. If the air conditioner is stopped, use the following procedure to start this operation.

Press the **MODE** button to select the operation mode.

Stable cooling operation → Stable heating operation → Stable operation cancellation

Display **A** COOL STABLE MODE → HEAT STABLE MODE → STABLE MODE CANCEL

Press the **FILTER** button.

Waiting for stable operation
Display **D** → 0 → 00 → 000 → 10-20 min. → 000

Stable operation

* You can check the data using steps (3) to (5) of the maintenance mode operation procedures while waiting for the stable operation.

This product is designed and intended for use in the residential,
commercial and light-industrial environment.

The product at hand is
based on the following
EU regulations:

- Low Voltage Directive 73/23/EEC
- Electromagnetic Compatibility Directive 89/
336/EEC
- Machinery Directive 2006/42/EC
- Energy-related Products Directive
2009/125/EC *
- * Only RP71/100
- RoHS 2011/65/EU

Please be sure to put the contact address/telephone number on
this manual before handing it to the customer.



MITSUBISHI ELECTRIC CORPORATION

HEAD OFFICE: TOKYO BLDG., 2-7-3, MARUNOUCHI, CHIYODA-KU, TOKYO 100-8310, JAPAN