

SERVICE MANUAL



Wireless type Models

MSC-A07YV - [E1] (WH)

MSC-A09YV - [E1] (WH)

MSC-A12YV - [E1] (WH)

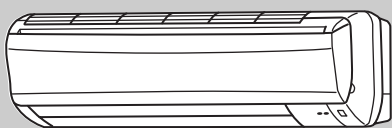

Indication of model name

MSC-A07YV - [E1]
MSC-A09YV - [E1]
MSC-A12YV - [E1]



CONTENTS

1. TECHNICAL CHANGES	3
2. PART NAMES AND FUNCTIONS.....	3
3. SPECIFICATION.....	5
4. NOISE CRITERIA CURVES	6
5. OUTLINES AND DIMENSIONS	7
6. WIRING DIAGRAM	8
7. REFRIGERANT SYSTEM DIAGRAM	8
8. MICROPROCESSOR CONTROL	9
9. SERVICE FUNCTIONS	17
10. TROUBLESHOOTING.....	19
11. DISASSEMBLY INSTRUCTIONS.....	26
12. PARTS LIST.....	28

NOTE:

- This manual describes technical data of indoor units.
- As for outdoor units MU-A07/A09/A12YV -[E1], refer to the service manual OB330.
- As for outdoor units MUH-A07/A09/A12YV -[E1], refer to the service manual OB331.
- As for outdoor units MUX-A10/A19/A20/A25/A26WV -[E1], refer to the service manual OB307 REVISED EDITION-A.
- As for outdoor units MUX-A22WV -[E1], refer to the service manual OB318.
- As for outdoor units MXZ-A18/A26/A32WV -[E1], refer to the service manual OB319.



1

TECHNICAL CHANGES

MSC-A07WV-^[E1] → MSC-A07YV-^[E1]

MSC-A09WV-^[E1] → MSC-A09YV-^[E1]

MSC-A12WV-^[E1] → MSC-A12YV-^[E1]

1. Design of front panel has changed.
2. Air filter has changed to the catechin air filter.

2

PART NAMES AND FUNCTIONS

MSC-A07YV -^[E1]

MSC-A09YV -^[E1]

MSC-A12YV -^[E1]

INDOOR UNIT

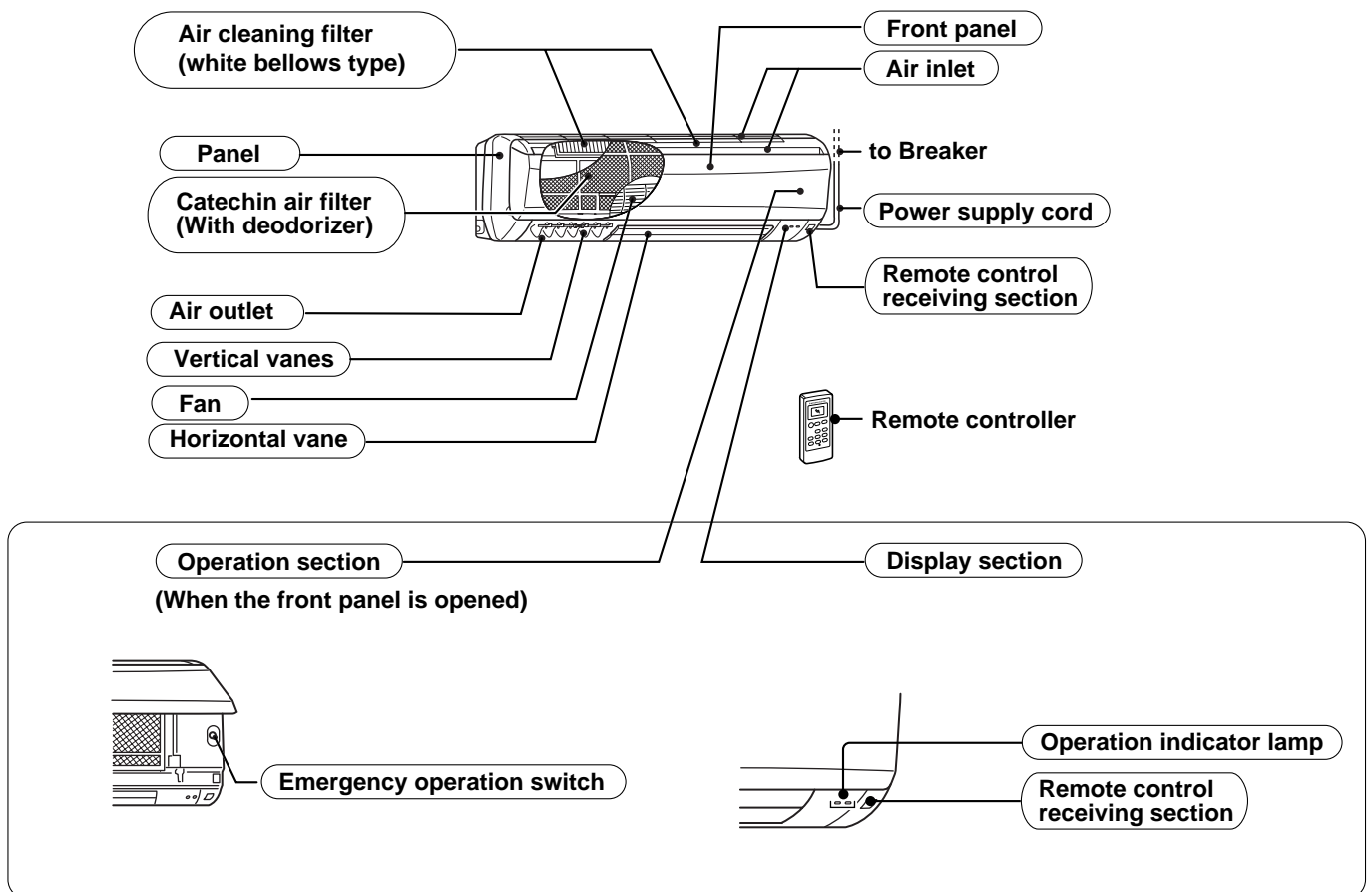

MSC-A07YV-E1
 MSC-A09YV-E1
 MSC-A12YV-E1

ACCESSORIES

<Indoor unit>

①	Installation plate	1
②	Installation plate fixing screw 4 × 25 mm	5
③	Remote controller holder	1
④	Fixing screw for ③ 3.5 × 16 mm	2
⑤	Battery (AAA) for remote controller	2
⑥	Wireless remote controller	1
⑦	Felt tape (Used for left or left-rear piping)	1
⑧	Air cleaning filter	1

REMOTE CONTROLLER

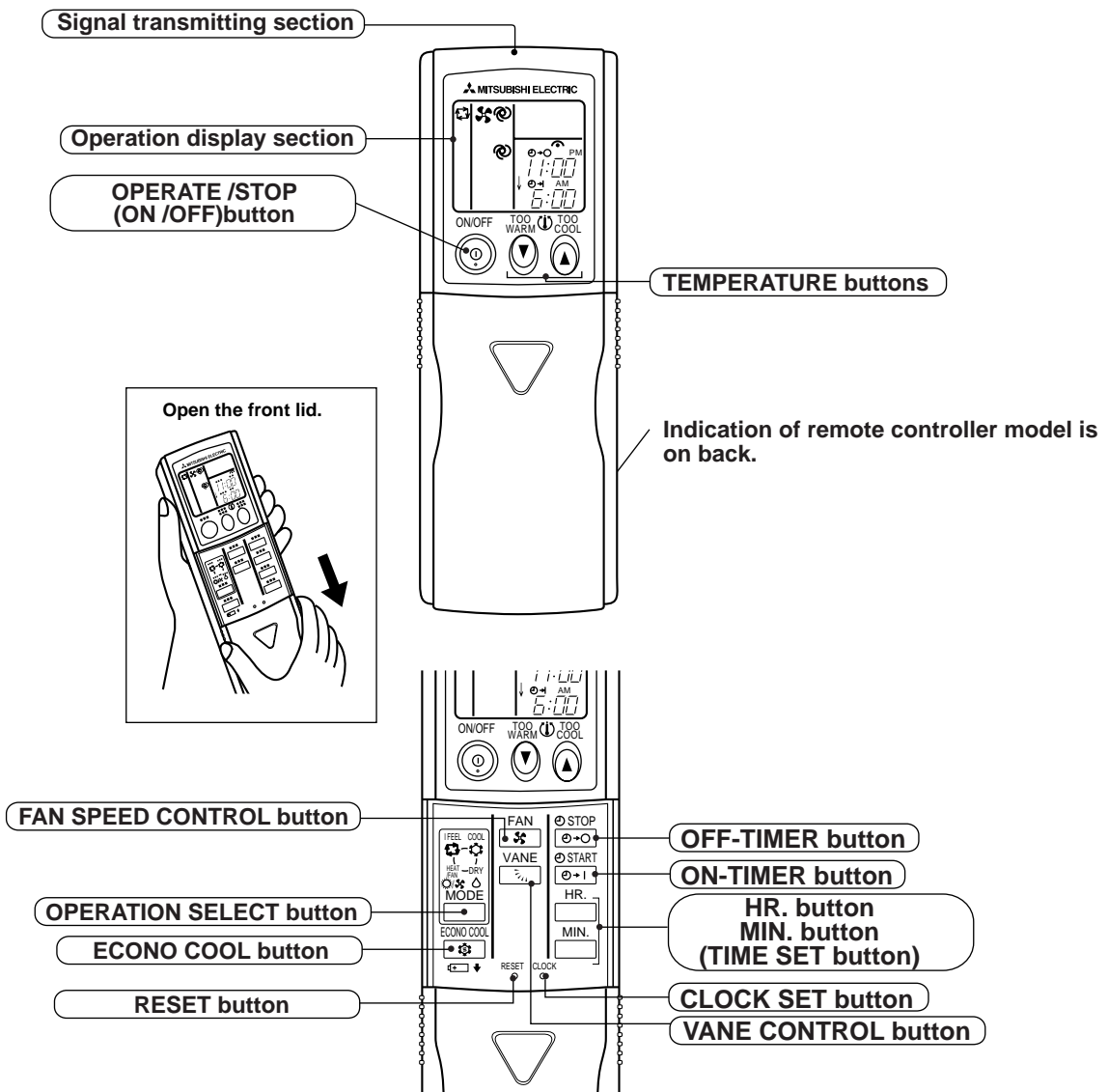

3

SPECIFICATION

Indoor model			MSC-A07YV - E1		MSC-A09YV - E1		MSC-A12YV - E1	
Function			Cooling	Heating	Cooling	Heating	Cooling	Heating
Indoor unit power supply			Single phase 230V,50Hz		Single phase 230V,50Hz		Single phase 230V,50Hz	
Capacity	Air flow(High/Med.*/Low*)	m ³ /h	474/372*/276*	510/420*/342*	474/384*/306*	588/456*/342*	582/444*/324*	606/498*/396*
Electrical data	Power outlet	A	10		10		10	
	Running current	A	0.17		0.17		0.19	
	Power input	W	35		35		40	
	Power factor	%	90		90		92	
	Fan motor current	A	0.17		0.17		0.19	
Fan motor	Model		RC4V19-LA		RC4V19-LA		RC4V19-KA	
	Winding resistance(at 20°C)	Ω	WHT-BLK 413 BLK-RED 334		WHT-BLK 413 BLK-RED 334		WHT-BLK 316 BLK-RED 299	
	Dimensions W×H×D	mm	815×278×244		815×278×244		815×278×244	
Weight	kg	9		9		10		
Air direction			5		5		5	
Special remarks	Sound level(High/Med.*/Low*)	dB	36/31*/25*	36/31*/25*	36/31*/25*	39/32*/25*	40/33*/26*	39/33*/26*
	Fan speed(High/Med.*/Low*)	rpm	900/750*/600*	950/820*/700*	900/770*/650*	1,050/870*/700*	930/760*/600*	960/830*/700*
	Fan speed regulator		3		3		3	
	Thermistor RT11(at 25°C)	kΩ	10		10		10	
	Thermistor RT12(at 25°C)	kΩ	10		10		10	
Remote controller model			KP1A or KG3A		KP1A or KG3A		KP1A or KG3A	

NOTE: 1. Test conditions are based on ISO 5151.

Cooling : Indoor

DB27°C WB19°C

Heating : Indoor DB20°C

Outdoor DB35°C WB24°C

OutdoorDB 7°C/WB 6°C

Indoor-Outdoor piping length 5m

2.Remote controller model KP1A and KG3A are the same in terms of specification.

* Reference value

NOISE CRITERIA CURVES

MSC-A07YV- E1

FAN SPEED	FUNCTION	SPL(dB(A))	LINE
High	COOL	36	●—●
	HEAT		○- - -○

Test conditions,
Cooling : DB27°C WB19°C
Heating : DB20°C WB -°C

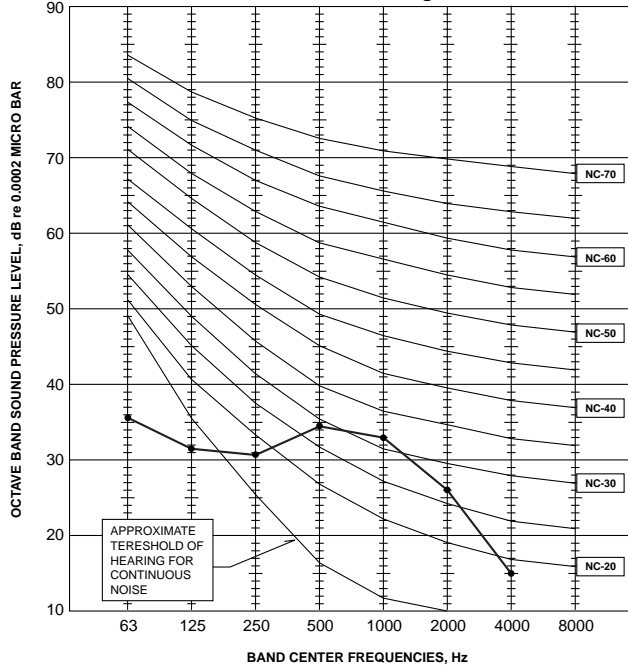

MSC-A09YV- E1

FAN SPEED	FUNCTION	SPL(dB(A))	LINE
High	COOL	36	●—●
	HEAT	39	○- - -○

Test conditions,
Cooling : DB27°C WB19°C
Heating : DB20°C WB -°C

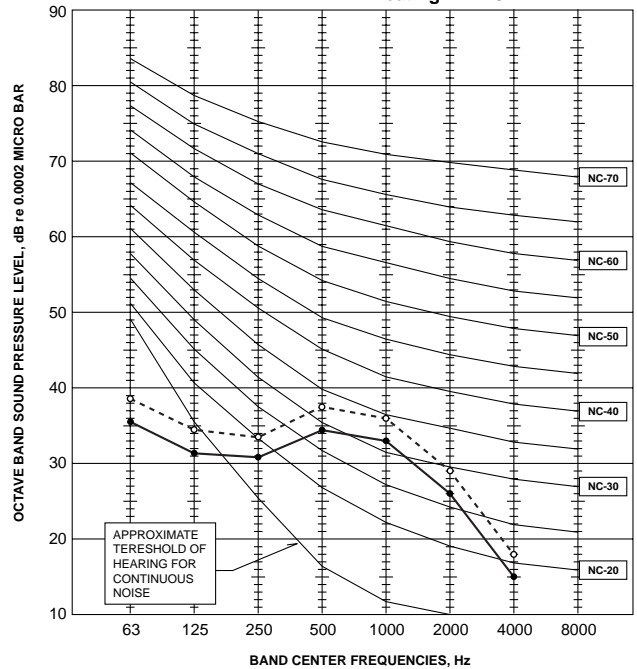

MSC-A12YV- E1

FAN SPEED	FUNCTION	SPL(dB(A))	LINE
High	COOL	40	●—●
	HEAT	39	○- - -○

Test conditions,
Cooling : DB27°C WB19°C

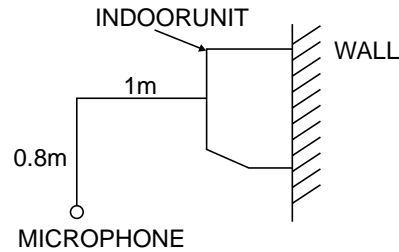
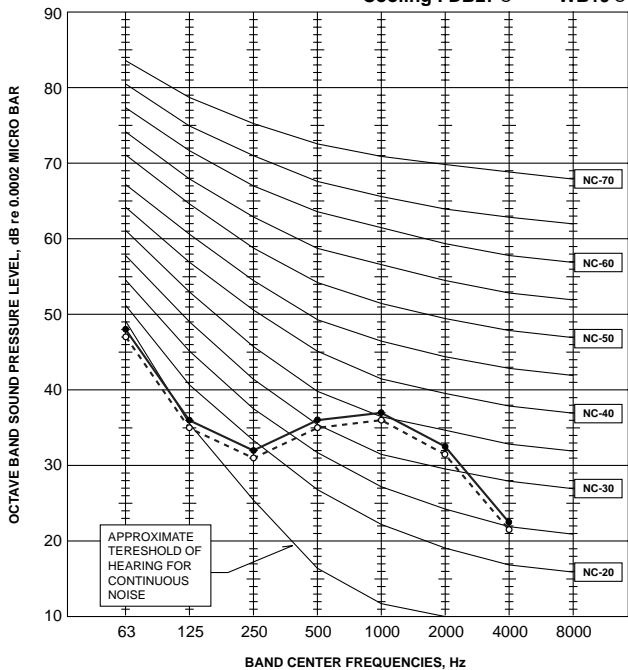

5

OUTLINES AND DIMENSIONS

MSC-A07YV -[E1]
MSC-A09YV -[E1]

Unit: mm

INDOOR UNIT

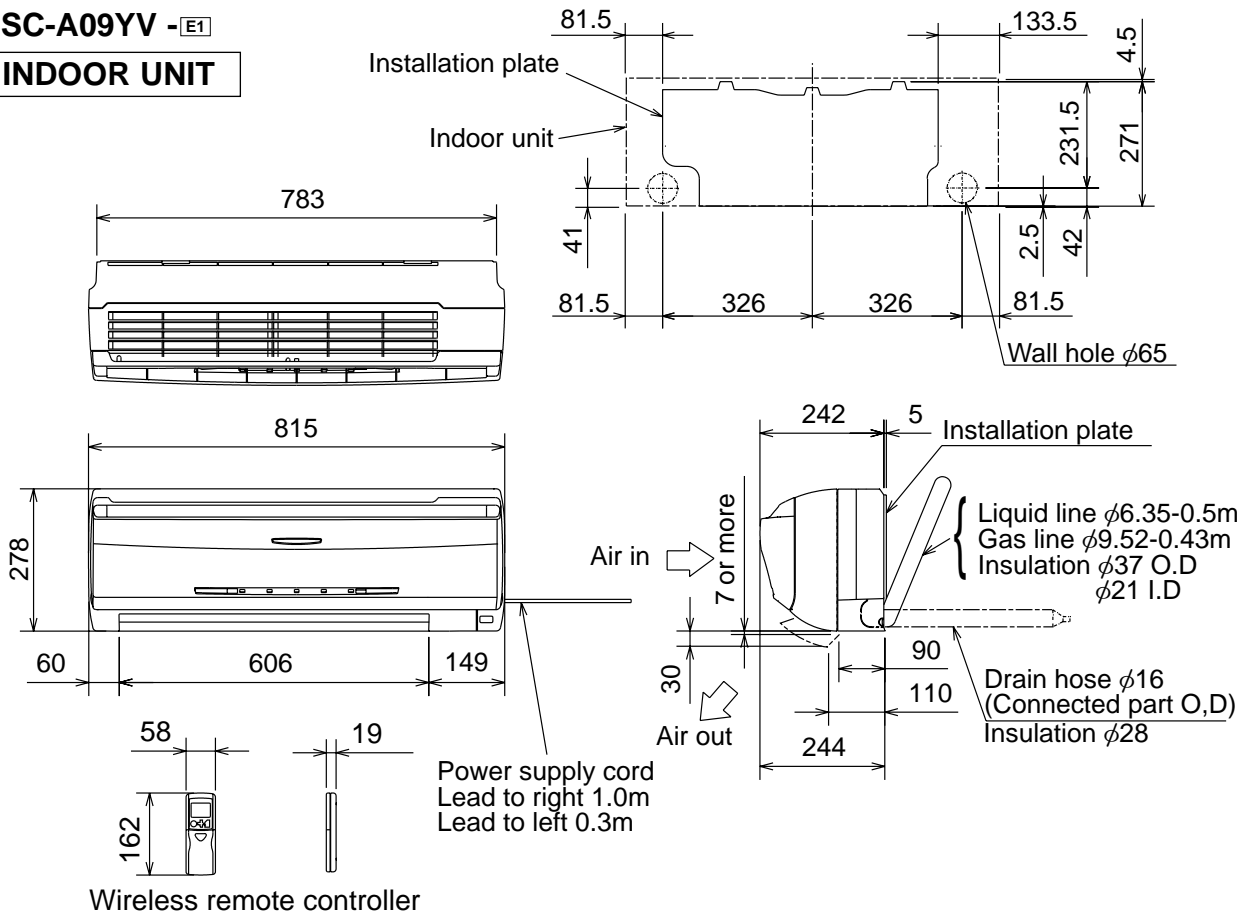

MSC-A12YV -[E1]

INDOOR UNIT

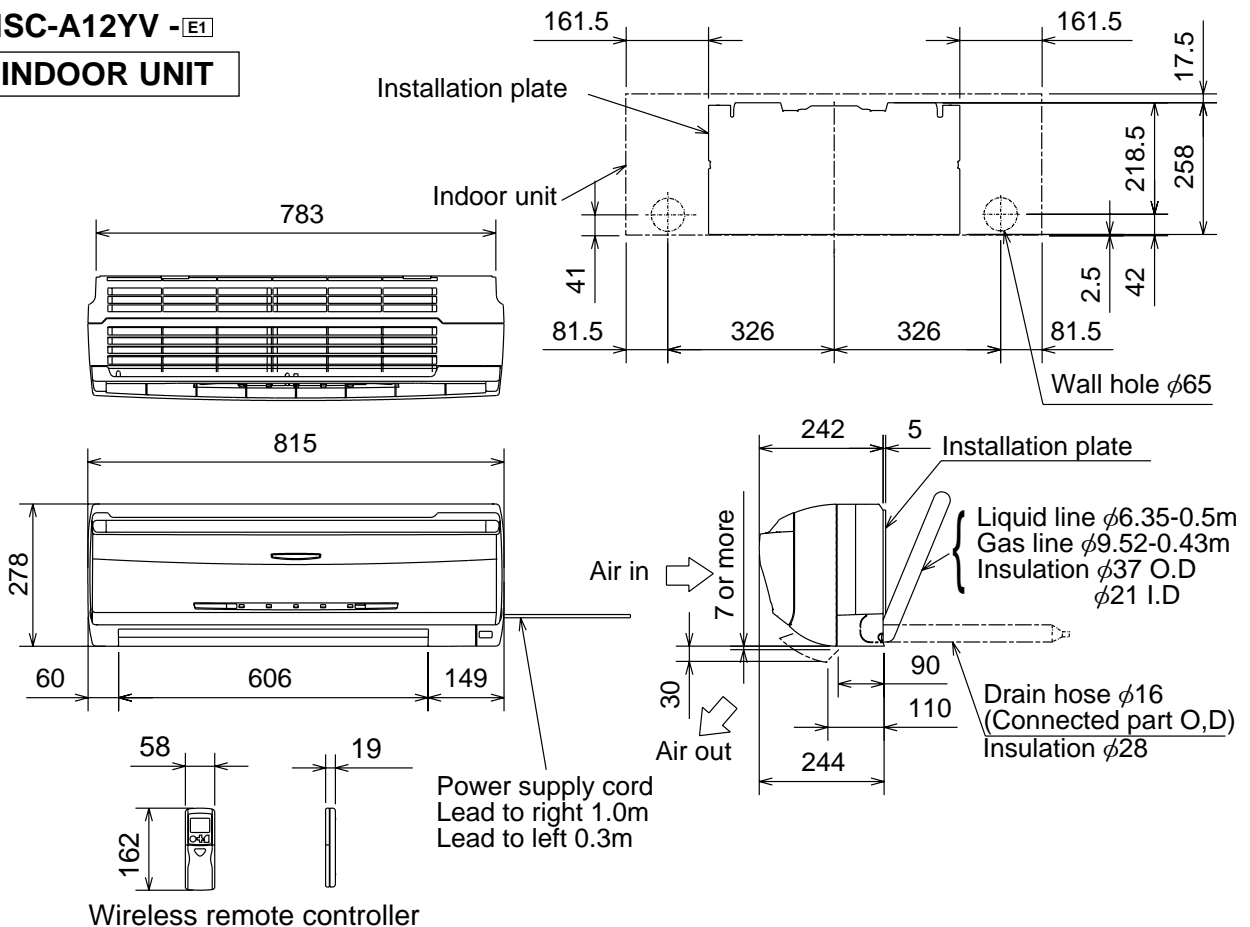

6

WIRING DIAGRAM

MSC-A07YV -[E1] MSC-A09YV -[E1] MSC-A12YV -[E1]

INDOOR UNIT

MODELS WIRING DIAGRAM

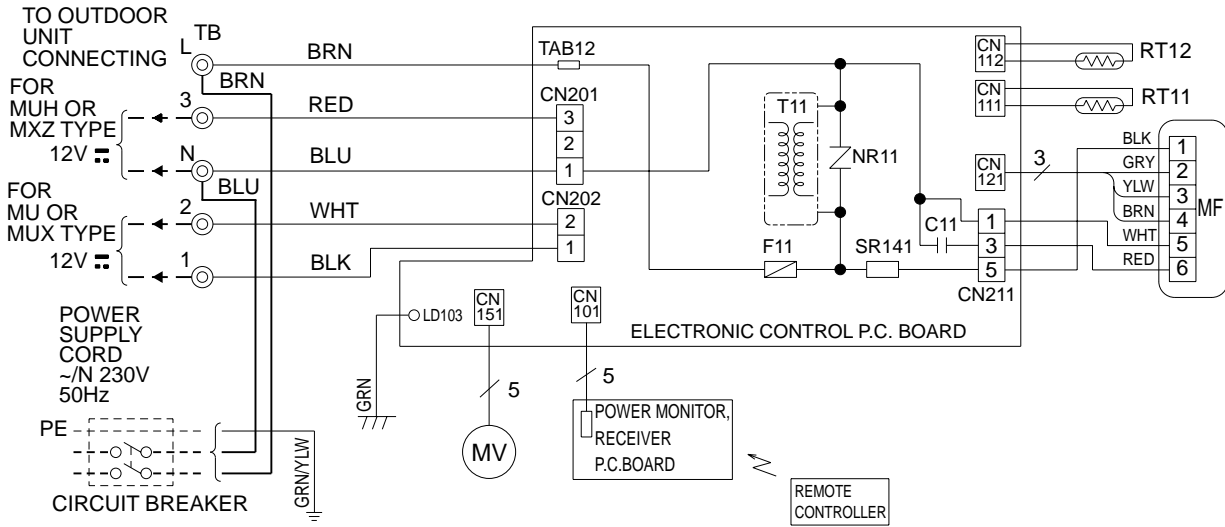

SYMBOL	NAME	SYMBOL	NAME	SYMBOL	NAME
C11	INDOOR FAN CAPACITOR	NR11	VARISTOR	TB	TERMINAL BLOCK
F11	FUSE(3.15A)	RT11	ROOM TEMPERATURE THERMISTOR	T11	TRANSFORMER
MF	INDOOR FAN MOTOR (INNER FUSE)	RT12	INDOOR COIL THERMISTOR		
MV	VANE MOTOR	SR141	SOLID STATE RELAY		

NOTE:1. About the outdoor side electric wiring refer to the outdoor unit electric wiring diagram for servicing.
 2. Use copper conductors only. (For field wiring)
 3. Symbols below indicate.
 ◎: Terminal block, □□□□: Connector

7

REFRIGERANT SYSTEM DIAGRAM

MSC-A07YV -[E1] MSC-A09YV -[E1]

MSC-A12YV -[E1]

Unit:mm

INDOOR UNIT

Refrigerant pipe $\phi 9.52$
(with heat insulator)

INDOOR UNIT

Refrigerant pipe $\phi 12.7$
(with heat insulator)

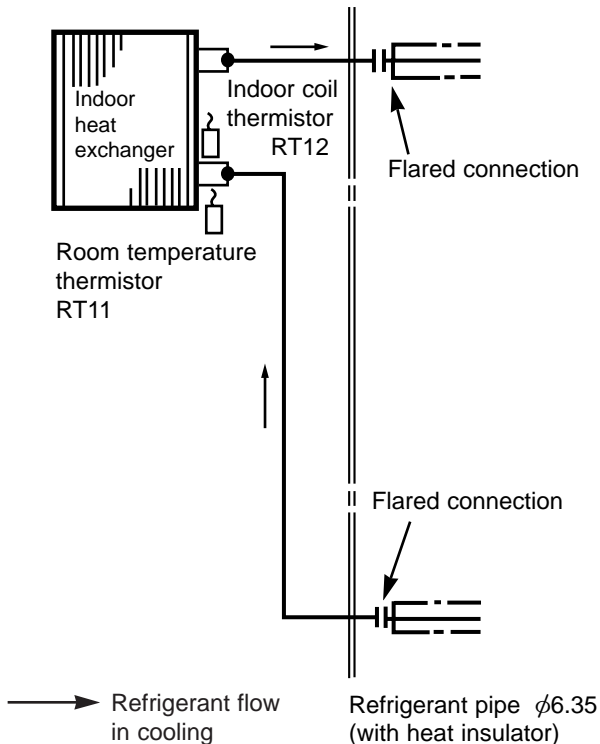
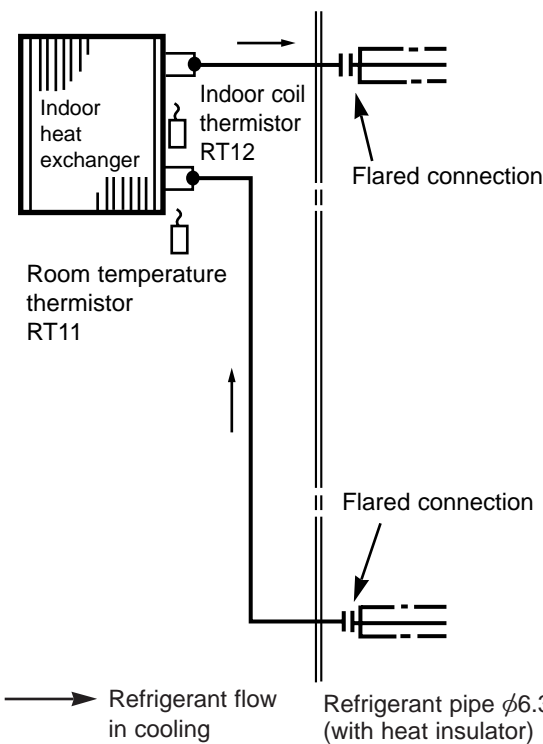

MSC-A07YV -E1

MSC-A09YV -E1

MSC-A12YV -E1

Once the operation mode are set, the same operation mode can be repeated by simply turning the OPERATE/STOP (ON/OFF) button ON. Indoor unit receives the signal with a beep tone.

When the system turns off, 3-minute time delay will operate to protect system from overload and compressor will not restart for 3 minutes.

WIRELESS REMOTE CONTROLLER

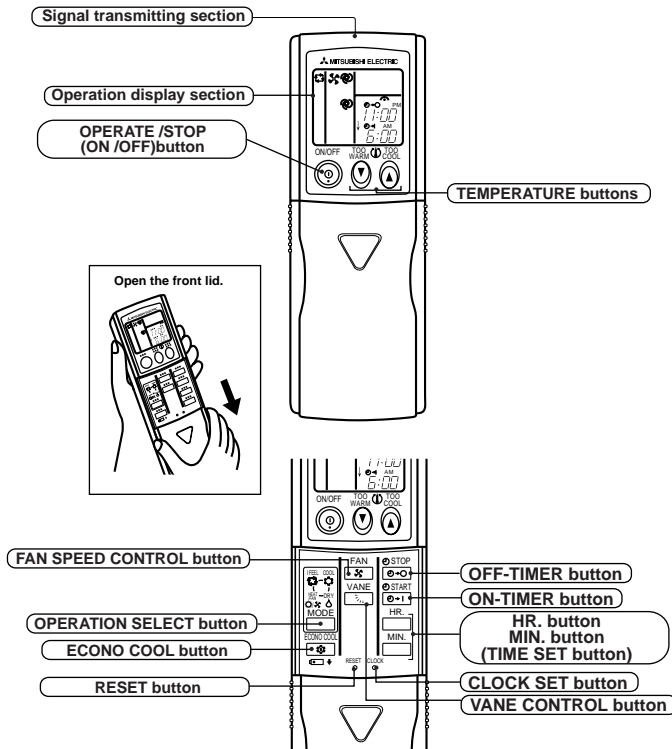

INDOOR UNIT DISPLAY SECTION

Operation Indicator lamp

The operation indicator at the right side of the indoor unit indicates the operation state.

- The following indication does not depend on the shape of lamp.

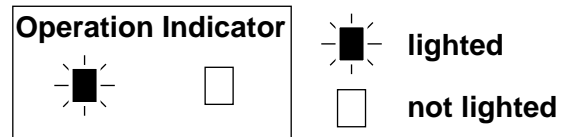

Indication	Operation state	Difference between target temperature and room temperature
	This shows that the air conditioner is operating to reach the target temperature. Please wait until the target temperature is obtained.	Approx. 2 °C or more
	This shows that the room temperature is approaching the target temperature.	Approx. 2 °C or less

8-1. COOL () OPERATION

- (1) Press OPERATE/STOP(ON/OFF) button. OPERATION INDICATOR lamp of the indoor unit turns on with a beep tone.
- (2) Select COOL mode with the OPERATION SELECT button.
- (3) Press TEMPERATURE buttons (TOO WARM or TOO COOL button)to select the desired temperature.
The setting range is 16 ~ 31°C

1. Thermostat control

Thermostat is ON or OFF by difference between room temperature and set temperature

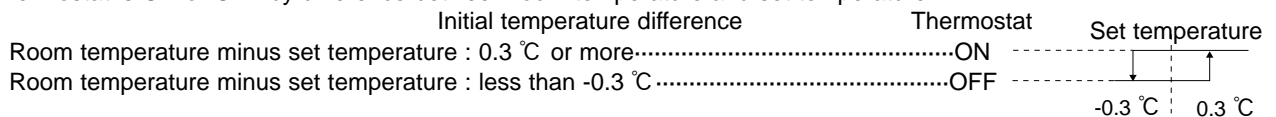

2. Indoor fan speed control

Indoor fan operates continuously at the set speed by FAN SPEED CONTROL button regardless of thermostat's OFF-ON.

In Auto the fan speed is as follows.

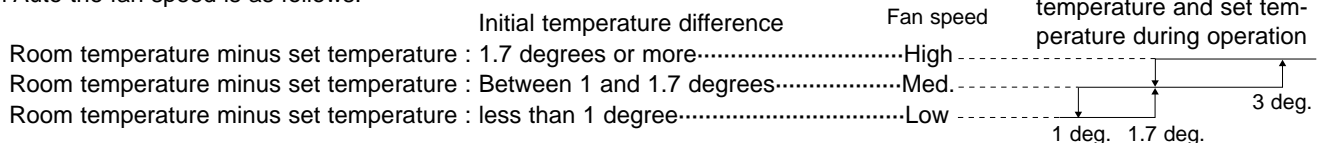

3. Coil frost prevention

① Temperature control

When the indoor coil thermistor RT12 reads 4°C or below(MSC-A07/A09YV) / 0°C or below(MSC-A12YV) for 5 minutes, the coil frost prevention mode starts.

The indoor fan operates at the set speed and the compressor stops for 5 minutes.

After that, if RT12 still reads below 4°C (MSC-A07/A09YV) / 0°C (MSC-A12YV), this mode is prolonged until the RT12 reads over 4°C (MSC-A07/A09YV) / 0°C (MSC-A12YV).

② Time control

When the three conditions as follows have been satisfied for 1 hour and 45 minutes, the compressor stops for 3 minutes. The indoor fan operates at the set speed.

- a. Compressor has been continuously operating.
- b. Indoor fan speed is Low or Med.
- c. Room temperature is below 26°C.

When compressor stops, the accumulated time is cancelled. When compressor restarts, time counting starts from the beginning.

Time counting also stops temporarily when the indoor fan speed becomes High or the room temperature exceeds 26°C. However, when two of the above conditions (b.and c.) are satisfied again, time accumulation is resumed.

Operation chart

Example

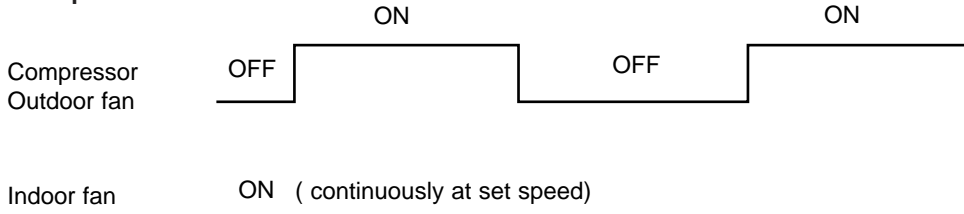

8-2. DRY (Δ) OPERATION

- (1) Press OPERATE/STOP(ON/OFF) button.
OPERATION INDICATOR lamp of the indoor unit turns on with a beep tone.
- (2) Select DRY mode with the OPERATION SELECT button.
- (3) The microprocessor reads the room temperature and determines the set temperature. Set temperature is as shown on the right chart.
DRY operation will not function when the room temperature is 13°C or below.
- (4) When DRY operation functions the fan speed is lower than COOL operation except at (fan speed) Low.

The system for dry operation uses the same refrigerant circuit as the cooling circuit.
The compressor and the indoor fan are controlled by the room temperature.

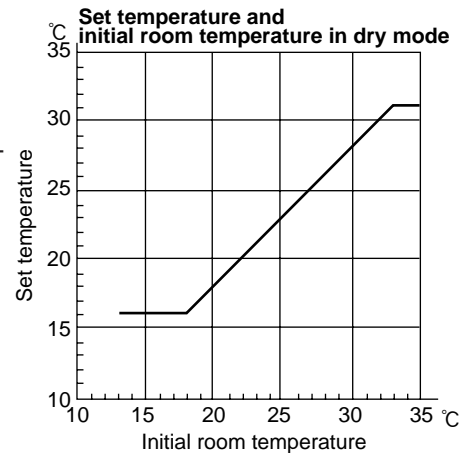

1. Thermostat control

Thermostat is ON or OFF by difference between room temperature and set temperature.

Difference between room temperature and set temperature during operation

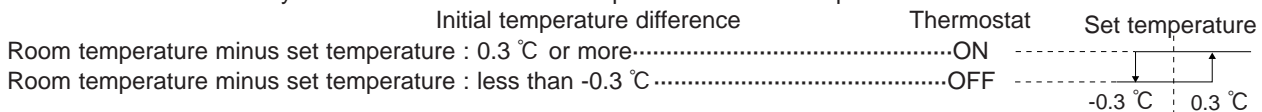

2. Indoor fan speed control

Indoor fan operates at the set speed by FAN SPEED CONTROL button.
In Auto fan speed becomes Low.

3. The operation of the compressor and indoor / outdoor fan

<MU-A07/A09/A12YV, MUH-A07/A09/A12YV, MUX-A10/A19/A20/A22/A25/A26WV>

Compressor operates by room temperature control and time control.

Indoor fan and outdoor fan operate in the same cycle as the compressor.

- When the room temperature is 23°C or over:
 - When the thermostat is ON, the compressor repeats 8 minutes ON and 3 minutes OFF.
 - When the thermostat is OFF, the compressor repeats 4 minutes OFF and 1 minute ON.
- When the room temperature is under 23°C.
 - When the thermostat is ON, the compressor repeats 2 minutes ON and 3 minutes OFF.
 - When the thermostat is OFF, the compressor repeats 4 minutes OFF and 1 minute ON.

Operation time chart
Example

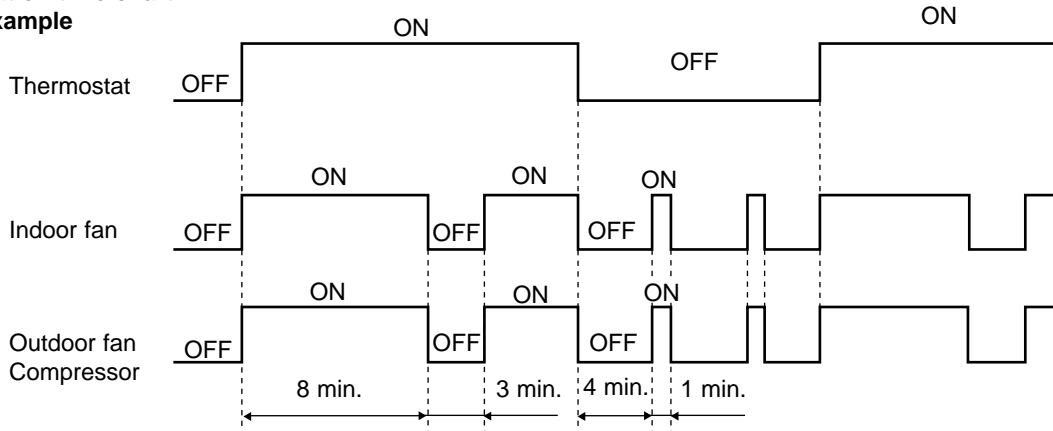

4. Coil frost prevention

The operation is as same as coil frost prevention during COOL operation.(Refer to 8-1.3.)
However when coil frost prevention works while the indoor fan is OFF, its speed becomes set speed.

8-3. FAN (*) OPERATION <MU-A07/A09/A12YV, MUX-A10/A19/A20/A22/A25/A26WV>

- (1) Press OPERATE/STOP(ON/OFF) button. OPERATION INDICATOR lamp of the indoor unit turns on with a beep tone.
- (2) Select FAN mode with the OPERATION SELECT button.
- (3) Select the desired fan speed. When AUTO, it becomes Low.
Only indoor fan operates.
Outdoor unit does not operate.

8-4. HEAT (☼) OPERATION <MUH-A07/A09/A12YV, MXZ-A18/A26/A32WV>

- (1) Press OPERATE/STOP(ON/OFF) button.
OPERATION INDICATOR lamp of the indoor unit turns on with a beep tone.
- (2) Select HEAT mode with the OPERATION SELECT button.
- (3) Press TEMPERATURE buttons (TOO WARM or TOO COOL button) to select the desired temperature.
The setting range is 16 ~ 31°C.

1. Thermostat control

Thermostat is ON or OFF by difference between room temperature and set temperature.

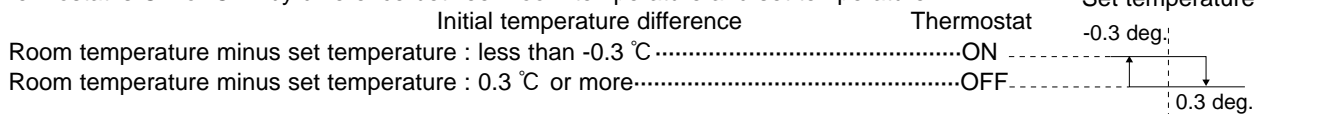

2. Indoor fan speed control

- (1) Indoor fan operates at the set speed by FAN SPEED CONTROL button.
In Auto the fan speed is as follows.

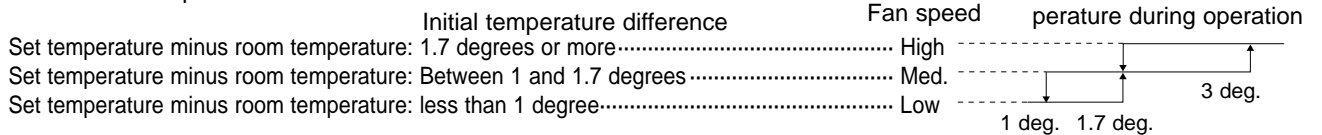

- (2) Cold air prevention control

- ① When the compressor is not operating,
 - (I) if the temperature of indoor coil thermistor RT12 is 0°C or less, the fan stops.
 - (II) if the temperature of indoor coil thermistor RT12 is more than 0°C, the fan operates at Very Low.
- ② When the compressor is operating,
 - (I) if the temperature of RT12 is 22°C or more, the fan operates at set speed.
 - (II) if the temperature of RT12 is less than 22°C and
 - (i) if the temperature of room temperature thermistor RT11 is 15°C or less, the fan stops.
 - (ii) if the temperature of room temperature thermistor RT11 is more than 15°C, the fan operates at Very Low.

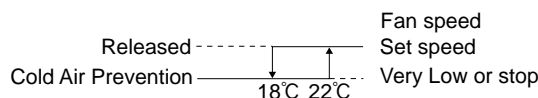

NOTE : If the temperature of RT12 reads from 18°C to 22°C at the air conditioner starting and also after defrosting, this control works.

(3) Warm air control.

When the following any condition of ① (a. ~ c.) and the condition of ② are satisfied at the same time, warm air control works.

- ① a.) When outdoor unit starts operating in HEAT mode.
- b.) When cold air prevention has been released.
- c.) When defrosting has been finished
- ② When the temperature of indoor coil thermistor RT12 is less than 37°C.

When warm air control works, the fan speed changes as follows to blow out warm air gradually.

Gradation of fan speed in initial

<Time condition>	<Indoor fan speed>
less than 2 minutes-----	Low
2 minutes to 4 minutes-----	Med.
more than 4 minutes-----	High

The upper limit of the fan speed in MANUAL is the set speed.

The upper limit of the fan speed in AUTO is the speed decided by indoor fan speed control.(Refer to 8-4.2.(1).)

When the temperature of RT12 has been 37°C or more, or when the set speed has been changed, this control is released and the fan speed is the set speed.

NOTE: As for high pressure protection, defrosting and R.V. coil control, refer to service manual for outdoor unit.

8-5. "I FEEL CONTROL" () OPERATION

- (1) Press OPERATE/STOP(ON/OFF) button.
OPERATION INDICATOR lamp of the indoor unit turns on with a beep tone.
- (2) Select "I FEEL CONTROL"() mode with the OPERATION SELECT button.
- (3) The operation mode is determined by the initial room temperature at start-up of the operation, as shown on the right table.

Initial room temperature		Mode
MU & MUX type	MUH & MXZ type	
25°C or more	25°C or more	COOL mode of "I FEEL CONTROL"
more than 13°C, less than 25°C	23°C or more, less than 25°C	DRY mode of "I FEEL CONTROL"
—————	less than 23°C	HEAT mode of "I FEEL CONTROL"

- Once the mode is fixed, the mode does not change by room temperature afterwards.
- Under the ON-TIMER ($\oplus \rightarrow |$) operation, mode is determined according to the room temperature at set time the operation starts.
- When the system is stopped on the remote controller and restarted within 2 hours in "I FEEL CONTROL" () mode, the system operates in previous mode automatically regardless of the room temperature.

Operation time chart

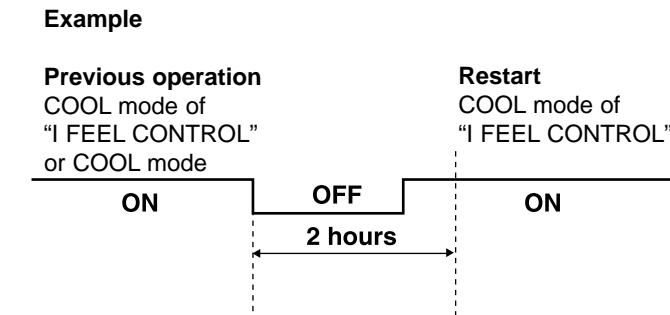

When the system is restarted after 2 hours and more, the operation mode is determined by the room temperature at start-up of the operation.

Operation time chart

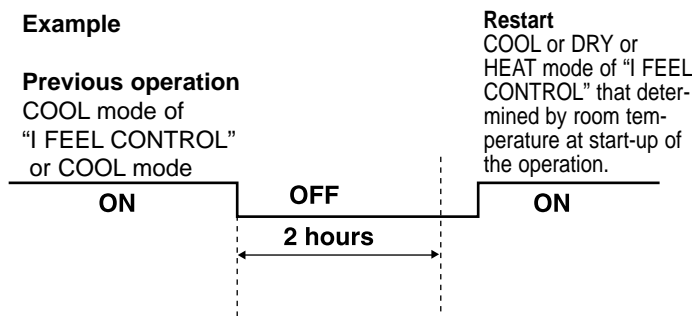

(4) The initial set temperature is decided by the initial room temperature.

Mode	Initial room temperature		Initial set temperature	
	MU & MUX type	MUH & MXZ type		
COOL mode of "I FEEL CONTROL"	26°C or more	26°C or more	24°C	※1
	25°C or more, less than 26°C	25°C or more, less than 26°C	Initial room temperature minus 2°C	
DRY mode of "I FEEL CONTROL"	more than 13°C, less than 25°C	23°C or more, less than 25°C	Initial room temperature minus 2°C	
HEAT mode of "I FEEL CONTROL"	————	less than 23°C	26°C	

※1 When the system is restarted with the remote controller, the system operates with the previous set temperature regardless of the room temperature at restart.

(5) TEMPERATURES buttons

In "I FEEL CONTROL" (□) mode, set temperature is decided by the microprocessor based on the room temperature. In addition, set temperature can be controlled by TOO WARM or TOO COOL buttons when you feel too cool or too warm. Each time the TOO WARM or TOO COOL button is pressed, the indoor unit receives the signal and emits a beep tone.

● Fuzzy control

When the TOO COOL or TOO WARM button is pressed, the microprocessor changes the set temperature, considering the room temperature, the frequency of pressing TOO COOL or TOO WARM button and the user's preference to heat or cool. So this is called "Fuzzy control", and works only in "I FEEL CONTROL" mode. In DRY mode of "I FEEL CONTROL", the set temperature doesn't change.



... To raise the set temperature 1~2 degrees(°C)



... To lower the set temperature 1~2 degrees(°C)

8-5-1. COOL mode of "I FEEL CONTROL"

1. Thermostat control

Thermostat control is as same as COOL OPERATION.(8-1.1.)

2. Indoor fan speed control

Indoor fan speed control is as same as COOL OPERATION.(8-1.2.)

3. Coil frost prevention

Coil frost prevention is as same as COOL OPERATION.(8-1.3.)

8-5-2. DRY mode of "I FEEL CONTROL"

1. Thermostat control

Thermostat control is as same as DRY OPERATION.(8-2.1.)

2. Indoor fan speed control

Indoor fan speed control is as same as DRY OPERATION.(8-2.2.)

3. The operation of the compressor and indoor/outdoor fan

The operation of the compressor and indoor/outdoor fan is as same as DRY OPERATION.(8-2.3.)

4. Coil frost prevention

Coil frost prevention is as same as DRY OPERATION.(8-2.4.)

8-5-3. HEAT mode of "I FEEL CONTROL" <MUH-A07/A09/A12YV, MXZ-A18/A26/A32WV>

1. Thermostat control

Thermostat control is as same as HEAT OPERATION.(8-4.1.)

2. Indoor fan speed control

Indoor fan speed control is as same as HEAT OPERATION.(8-4.2.)

NOTE: As for high pressure protection, defrosting and R.V. coil control, refer to service manual for outdoor unit.

8-6. FAN MOTOR CONTROL

(1) Rotational frequency feedback control

The indoor fan motor is equipped with a rotational frequency sensor, and outputs signal to the microprocessor to feedback the rotational frequency. Comparing the current rotational frequency with the target rotational frequency (High,Med.,Low), the microprocessor controls SR141 and adjusts fan motor electric current to make the current rotational frequency close to the target rotational frequency. With this control, when the fan speed is switched, the rotational frequency changes smoothly.

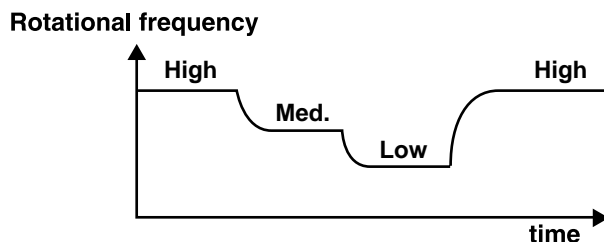

(2) Fan motor lock-up protection

When the rotational frequency feedback signal is not output for 12 seconds, (or when the microprocessor cannot detect the signal for 12 seconds) the fan motor is regarded locked-up. Then the electric current to the fan motor is shut off. 3 minutes later, the electric current is applied to the fan motor again. During the fan motor lock-up, the OPERATION INDICATOR lamp flashes on and off to show the fan motor abnormality. (Refer to page 21.)

8-7. AUTO VANE OPERATION

(1) Vane motor drive

These models are equipped with a stepping motor for the horizontal vane. The rotating direction, speed, and angle of the motor are controlled by pulse signals (approx. 12V) transmitted from indoor microprocessor.

(2) The horizontal vane angle and mode changes as follows by pressing the VANE CONTROL button.

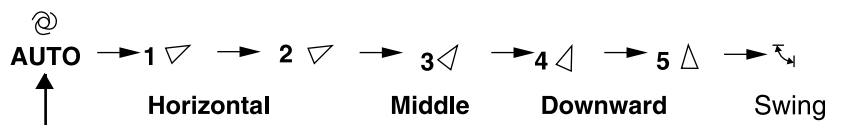

(3) Positioning

The vane is once pressed to the vane stopper below to confirm the standard position and then set to the desired angle. Confirming of standard position is performed in case of follows.

- When the OPERATE/STOP(ON/OFF) button is pressed.
- When the vane control is changed from AUTO to MANUAL.
- When the SWING is finished.
- When the test run starts.
- When the power supply turns ON.

(4) VANE AUTO (Ⓐ) mode

In VANE AUTO mode, the microprocessor automatically determines the vane angle to make the optimum room-temperature distribution.

- In COOL and DRY operation

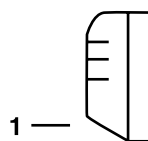

Vane angle is fixed to Angle 1.

- In FAN operation

<MU-A07/A09/A12YV,
MUX-A10/A19/A20/A22/A25/A26WV>

- In HEAT operation

<MUH-A07/A09/A12YV, MXZ-A18/A26/A32WV>

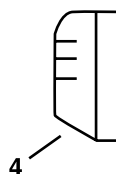

Vane angle is fixed to Angle 4.

(5) Dew prevention

During COOL or DRY operation at Vane Angle 4 or 5 when the cumulative operation time of compressor exceeds 1 hour, the vane angle automatically changes to Angle 1 for dew prevention.

(6) SWING MODE (Ⓕ) mode

By selecting SWING mode with the VANE CONTROL button, the horizontal vane swings vertically. The remote controller displays “Ⓕ”.

(7) Cold air prevention in HEAT operation <MUH-A07/A09/A12YV, MXZ-A18/A26/A32WV>

When any of the following conditions occurs in HEAT operation, the horizontal vane angle changes to Angle 1 automatically to prevent cold air blowing on users.

- ① Compressor is not operating.
- ② Defrosting is performed.
- ③ Indoor coil thermistor RT12 reads 24°C or below.
- ④ Indoor coil thermistor RT12 temperature is raising from 24°C or below, but it does not exceed 28°C.

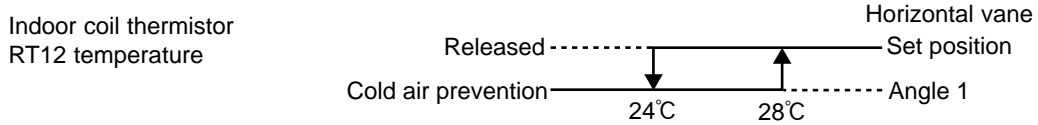

NOTE : If the temperature of RT12 reads from 24°C to 28°C at the air conditioner stating , this control works.

(8) ECONO COOL () operation (ECONOMical operation)

When the ECONO COOL button is pressed in COOL mode, set temperature is automatically set 2°C higher than that in COOL mode.

Also the horizontal vane swings in various cycle according to the temperature of indoor heat exchanger(RT12).

SWING operation makes you feel cooler than set temperature. So, even though the set temperature is higher than that in COOL mode, the air conditioner can keep comfort. As a result, energy can be saved.

ECONO COOL operation is cancelled when the ECONO COOL button is pressed once again or VANE CONTROL button is pressed or operation mode is changed.

NOTE : ECONO COOL operation does not work in COOL mode of “I FEEL CONTROL”.

SWING operation

In swing operation of ECONO COOL operation mode, the initial air flow direction is adjusted to “Horizontal”.

According to the temperature of indoor coil thermistor RT12 at starting of this operation, next downward blow time is decided. Then when the downward blow has been finished, next upward blow time is decided.

For initial 10 min. the swing operation is performed in table G~H for quick cooling.

Also, after 10 min. when the difference of set temperature and room temperature is more than 2 degrees, the swing operation is performed in table D~H for more cooling.

The air conditioner repeats the swing operation in various cycle as follows.

	Temperature of indoor coil thermistor RT12	Downward blow time (sec.)	Horizontal blow time (sec.)
A	15°C or less	2	23
B	15°C to 17°C	5	20
C	17°C to 18°C	8	17
D	18°C to 20°C	11	14
E	20°C to 21°C	14	11
F	21°C to 22°C	17	8
G	22°C to 24°C	20	5
H	more than 24°C	23	2

8-8. TIMER OPERATION

1. How to set the timer

(1) Press OPERATE/STOP(ON/OFF) button to start the air conditioner.

(2) Check that the current time is set correctly.

NOTE : Timer operation will not work without setting the current time. Initially “AM0:00” blinks at the current time display of TIME MONITOR, so set the current time correctly with CLOCK SET button.

(3) Press ON or OFF TIMER buttons to select the operation.

“→|” button... AUTO START operation (ON timer)

“→○” button... AUTO STOP operation (OFF timer)

(4) Press HR. and MIN. button to set the timer. Time setting is 10-minute units.

HR. and MIN. button will work when “ ⊕→| ” or “ ⊕→○ ” mark is flashing.

These marks disappear in 1 minute.

After setting the ON timer, check that OPERATION INDICATOR lamp of the indoor unit lights.

NOTE1 : Be sure to place the remote controller at the position where its signal can reach the air conditioner even during TIMER operation, or the set time may deviate within the range of about 10 minutes.

NOTE2 : Reset the timer in the following cases, or the set time may deviate and other malfunctions may occur.

- A power failure occurs.
- The circuit breaker functions.

2. Cancel

TIMER setting can be cancelled with the ON or OFF TIMER buttons. (“ ⊕→| ” or “ ⊕→○ ”)

To cancel the ON timer, press the “ ⊕→| ” button.

To cancel the OFF timer, press the “ ⊕→○ ” button.

TIMER is cancelled and the display of set time disappears.

PROGRAM TIMER

- The OFF timer and ON timer can be used in combination.
- “ ↑ ” and “ ↓ ” display shows the order of the OFF timer and ON timer operation.

(Example 1) The current time is 8:00 PM.

The unit turns off at 11:00 PM, and on at 6:00 AM.

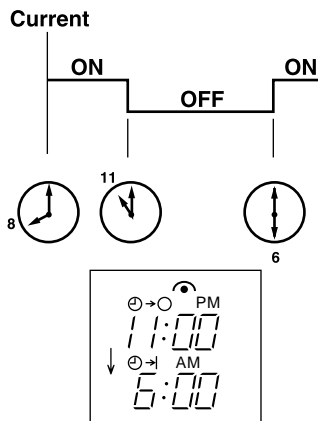

(Example 2) The current time is 11:00 AM.

The unit turns on at 5:00 PM, and off at 9:00 PM.

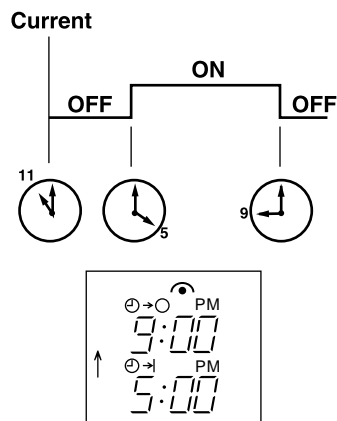

NOTE : TIMER setting will be cancelled by power failure or breaker functioning.

8-9. EMERGENCY-TEST OPERATION

In case of test run operation or emergency operation, use the EMERGENCY OPERATION switch on the front of the indoor unit. Emergency operation is available when the remote controller is missing, has failed or the batteries of remote controller run down. The unit will start and the OPERATION INDICATOR lamp will light.

The first 30 minutes of operation is the test run operation. This operation is for servicing. The indoor fan speed runs at High speed and the system is in continuous operation. (The thermostat is ON.)

After 30 minutes of test run operation the system shifts to EMERGENCY COOL [/ HEAT<MUH-A07/A09/A12YV, MXZ-A18/A26/A32WV>] MODE with a set temperature of 24°C. The fan speed shifts to Med. speed.

The coil frost prevention works even in emergency operation [, and defrosting<MUH-A07/A09/A12YV, MXZ-A18/A26/A32WV> too].

In the test run or emergency operation, the horizontal vane operates in VANE AUTO (@) mode.

Emergency operation continues until the EMERGENCY OPERATION switch is pressed once again (MU-A07/A09/A12YV, MUX-A10/A19/A20/A22/A25/A26WV)/once or twice (MUH-A07/A09/A12YV, MXZ-A18/A26/A32WV) or the unit receives any signal from the remote controller.

In case of latter normal operation will start.

NOTE : Do not press the EMERGENCY OPERATION switch during normal operation.

- The following indication does not depend on the shape of lamp.

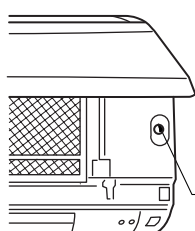

EMERGENCY OPERATION switch



OPERATION INDICATOR lamp

Press once <Cool>



Press again <Heat>

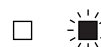

Press once again <Stop>

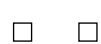

※ Heat is available only in MUH-A07/A09/A12YV and MXZ-A18/A26/A32WV.

MSC-A07YV -E1

MSC-A09YV -E1

MSC-A12YV -E1

9-1. TIMER SHORT MODE

For service, set time can be shortened by short circuit of JPG and JPS the electronic control P.C. board.

The time will be shortened as follows. (Refer to page 25.)

Set time : 1 minute → 1-second

Set time : 3 minutes → 3-second (It takes 3 minutes for the compressor to start operation. However, the starting time is shortened by short circuit of JPG and JPS.)

9-2. P.C. BOARD MODIFICATION FOR INDIVIDUAL OPERATION

A maximum of 4 indoor units with wireless remote controllers can be used in a room.

In this case, to operate each indoor unit individually by each remote controller, P.C. boards of remote controller must be modified according to the number of the indoor unit.

How to modify the remote controller P.C. board

Remove batteries before modification. The board has a print as shown below :

Remote controller model : KP1A

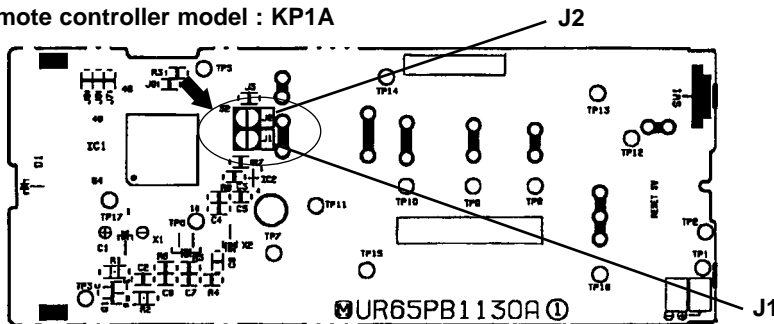

Remote controller model : KG3A

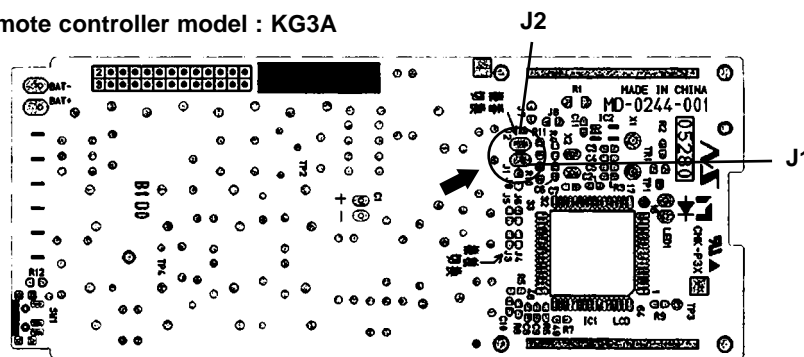

- NOTE :**
1. For remodelling, take out the batteries and press the OPERATE/STOP(ON/OFF) button twice or 3 times at first. After finish remodelling, put back the batteries then press the RESET button.
 2. Remote controller model KP1A and KG3A are the same in terms of specification.

The P.C. board has the print "J1" and "J2". Solder "J1" and "J2" according to the number of indoor unit as shown in Table 1. After modification, press the RESET button.

Table 1

	1 unit operation	2 units operation	3 units operation	4 units operation
No. 1 unit	No modification	Same as at left	Same as at left	Same as at left
No. 2 unit	—	Solder J1	Same as at left	Same as at left
No. 3 unit	—	—	Solder J2	Same as at left
No. 4 unit	—	—	—	Solder both J1 and J2

How to set the remote controller exclusively for particular indoor unit

After you turn the breaker ON, the first remote controller that sends the signal to the indoor unit will be regarded as the remote controller for the indoor unit.

The indoor unit will only accepts the signal from the remote controller that has been assigned to the indoor unit once they are set.

The setting will be cancelled if the breaker has turned off, or the power supply has shut down.

Please conduct the above setting once again after the power has restored.

9-3. REMOTE CONTROLLER (How to set the type)

This remote controller setting needs to be switched according to the type of air conditioner (COOL & HEAT or COOL ONLY).

If the setting is incorrect, the air conditioner does not operate normally. Therefore, check if the setting corresponds to the type of air conditioner. If not, correct the setting as shown below.

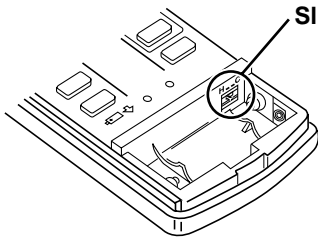

Slide switch

Type	COOL & HEAT	COOL ONLY
The position of the slide switch		

9-4. MU & MUX TYPE / MUH & MXZ TYPE SWITCH OVER AND AUTO RESTART FUNCTION

1. MU & MUX TYPE / MUH & MXZ TYPE SWITCH OVER

The indoor units for MU & MUX type and MUH & MXZ type are common specifications. Set switch according to the type of outdoor unit. The units are set for MUH & MXZ type when they are shipped from the factory.

SW2-① sets the AUTO RESTART FUNCTION ON / OFF.
SW2-② switches over the MU & MUX type / MUH & MXZ type.

When the units are shipped from the factory, SW2 is as follows.
SW2-①: AUTO RESTART FUNCTION ON
SW2-②: MUH & MXZ type

How to switch over MU & MUX TYPE / MUH & MXZ TYPE

- Turn off the main power for the unit.
- Pull out the electronic control P.C. board, and change switch(SW2-②) on the indoor electronic control P.C. board according to the type of outdoor unit as following figures.

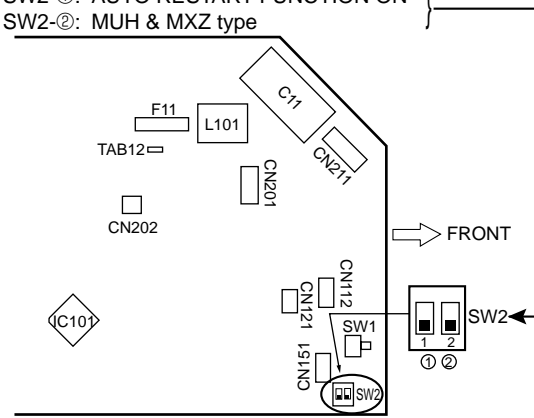

Outdoor unit MU & MUX type

Set ② switch upside.

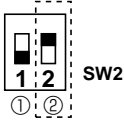

Outdoor unit MUH & MXZ type

Set ② switch downside.

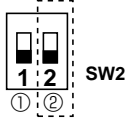

NOTE:•If the indoor-outdoor connecting wire is incorrectly connected on the terminal block, the unit does not operate normally.
•If a ground is incorrect, it may cause an electric shock.

2. AUTO RESTART FUNCTION

When the indoor unit is controlled with the remote controller, the operation mode, set temperature, and the fan speed are memorized by the indoor electronic control P.C.board. The "AUTO RESTART FUNCTION" sets to work the moment power has restored after power failure. Then, the unit will restart automatically. However if the unit is operated in "I FEEL CONTROL" mode before power failure, the operation is not memorized. In "I FEEL CONTROL" mode, the operation is decided by the initial room temperature. "AUTO RESTART FUNCTION" is ON when the units are shipped from the factory.

How to release "AUTO RESTART FUNCTION"

- Turn off the main power for the unit.
- Pull out the electronic control P.C. board, and change switch(SW2-①) on the indoor electronic control P.C. board as following figures.

AUTO RESTART FUNCTION ON

Set ① switch downside.

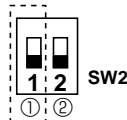

AUTO RESTART FUNCTION OFF

Set ① switch upside.

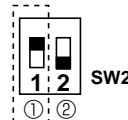

Operation

- If the main power (230V AC) has been cut, the operation settings remain.
- After the power is restored, the unit restarts automatically according to the memory. (However, it takes at least 3 minutes for the compressor to start running.)

NOTE

- The operation settings are memorized when 10 seconds have passed after the remote controller was operated.
- If main power is cut while AUTO START/STOP timer is active, the timer setting is cancelled.
- If the unit has been off with the remote controller before power failure, the auto restart function does not work as the power button of the remote controller is off.
- To prevent breaker off due to the rush of starting current, systematize other home appliance not to turn on at the same time.
- When some air conditioners are connected to the same supply system, if they are operated before power failure, the starting current of all the compressors may flow simultaneously at restart. Therefore, the special counter-measures are required to prevent the main voltage-drop or the rush of the starting current by adding system that allows the units to start one by one.

MSC-A07YV -[E1]

MSC-A09YV -[E1]

MSC-A12YV -[E1]

10-1. Cautions on troubleshooting

1. Before troubleshooting, check the following:

- 1) Check the power supply voltage.
- 2) Check the indoor/outdoor connecting wire for mis-wiring.

2. Take care the following during servicing.

- 1) Before servicing the air conditioner, be sure to first turn off the remote controller to stop the unit, and then after confirming the horizontal vane is closed, turn off the breaker and/or disconnect the power plug.
- 2) Be sure to turn OFF the power supply before removing the front panel, the cabinet, the top panel, and the electronic control P.C. board.
- 3) When removing the electronic control P.C. board, hold the edge of the board with care NOT to apply stress on the components.
- 4) When connecting or disconnecting the connectors, hold the housing of the connector. DO NOT pull the lead wires.

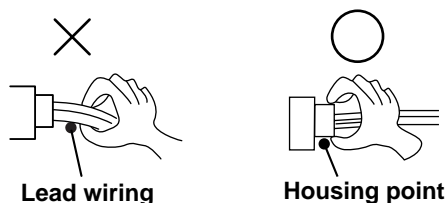

3. Troubleshooting procedure

- 1) First, check if the OPERATION INDICATOR lamp on the indoor unit is flashing on and off to indicate an abnormality. To make sure, check how many times the abnormality indication is flashing on and off before starting service work.
- 2) If the electronic control P.C. board is supposed to be defective, check the copper foil pattern for disconnection and the components for bursting and discoloration.
- 3) When troubleshooting, refer to the flow chart on page 20 and the check table on page 21.

4. How to replace batteries

Weak batteries may cause the remote controller malfunction.

In this case, replace the batteries to operate the remote controller normally.

- ① Remove the front lid and insert batteries. Then reattach the front lid.

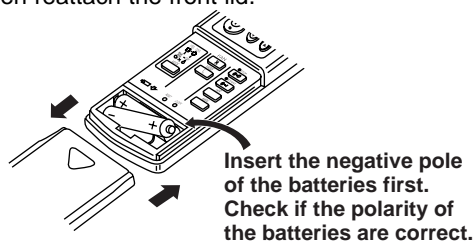

- ② Press the RESET button.

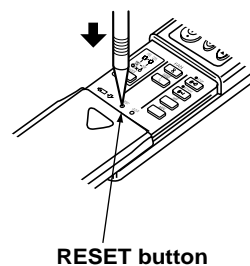

NOTE1 : If the RESET button is not pressed, the remote controller may not operate correctly.

NOTE2 : INFORMATION FOR MULTI SYSTEM AIR CONDITIONER

(OUTDOOR UNIT : MXZ-A18WV-[E1] MXZ-A26WV-[E1] MXZ-A32WV-[E1])

Multi system air conditioner (Outdoor unit MXZ-A18WV-[E1] MXZ-A26WV-[E1] MXZ-A32WV-[E1]) can connect two or more indoor units with one outdoor unit.

According to the capacity, two or more units can operate simultaneously.

- When you try to operate two or more indoor units with one outdoor unit simultaneously, one for the cooling and the other for heating, the operation mode of the indoor unit that operates earlier is selected. The other indoor units that will start the operation later cannot operate, indicating as shown in the figure below. In this case, please set all the indoor units to the same operation mode.

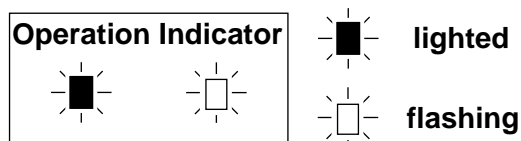

- When indoor units starts the operation while the defrosting of outdoor unit is being done, it takes a few minutes (max. 10 minutes) to blow out the warm air.

- In the heating operation, though indoor unit that does not operate may get warm or the sound of refrigerant flowing may be heard, they are not malfunction. The reason is that the refrigerant continuously flows into it.

10-2. Instruction of troubleshooting

MSC-A07YV -E1

MSC-A09YV -E1

MSC-A12YV -E1

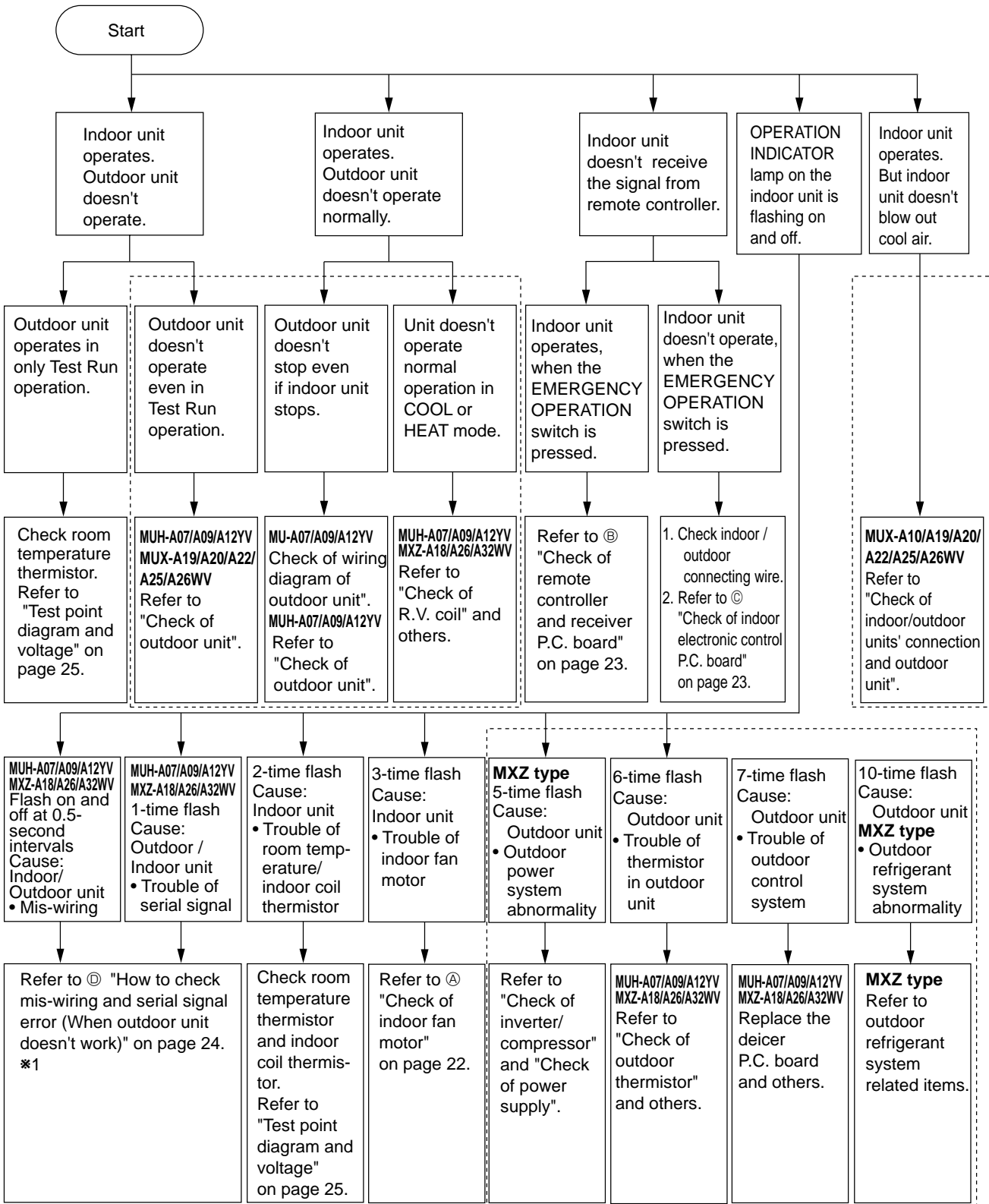

*1.<The case of the trouble of the serial signal>

When the power is turned off and then turned on again, the indication shows "the trouble of mis-wiring".

As for outdoor unit MU type, refer to service manual OB330.

As for outdoor unit MUH type, refer to service manual OB331.

As for outdoor unit MUX type, refer to service manual OB307 REVISED EDITION-A or OB318.

As for outdoor unit MXZ type, refer to service manual OB319.

10-3. Troubleshooting check table

- The following indication does not depend on the shape of lamp.

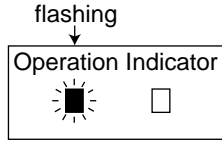

- Flashing of the OPERATION INDICATOR lamp (on the left-hand side) indicates possible abnormalities.
- The OPERATION INDICATOR lamp (on the left-hand side) is lighting during normal operation.

※ Before taking measures, make sure that the symptom reappears, for accurate troubleshooting.

Self check table

No.	Abnormal point	Operation indicator lamp	Symptom	Detection method	Checkpoint
1	MUH or MXZ type Mis-wiring	0.5-second ON 	Outdoor unit does not run.	When serial signal stops for 4 to 5 seconds after 1st on of 52C relay by POWER turning on.	<ul style="list-style-type: none"> ● Check switch SW2-②.(MU & MUX type or MUH & MXZ type) ● Check wiring (visual check and conductivity check). ● Check indoor electronic control P.C.board. ● Check outdoor DEICER P.C. board and others. ● Check electrical parts.
	MUH or MXZ type Serial signal	1-time flash 2.5-second OFF		When serial signal from outdoor unit stops for 4 to 5 seconds.	
2	Indoor coil thermistor	2-time flash 2.5-second OFF	Outdoor unit does not run.	Detect Indoor coil/room temperature thermistor short or open circuit every 8 seconds during operation.	<ul style="list-style-type: none"> ● Check resistance of thermistor. ● Reconnect connector. ● Check indoor electronic control P.C.board.
	Room temperature thermistor				
3	Indoor fan motor	3-time flash 2.5-second OFF	Indoor fan motor repeats 12 seconds ON and 3 minutes OFF. When the indoor fan motor breaks, the fan keeps stopping.	When rotational frequency feedback pulse signal is not emit during 12-second indoor fan operation.	<ul style="list-style-type: none"> ● Disconnect connector CN211 and then check connector CN121 ②-③ to make sure rotational frequency feedback signal of 1.5V or over exists. ● Check indoor electronic control P.C. board. ● Check indoor fan motor. ● Reconnect connector.
4	MXZ type Outdoor power system	5-time flash 2.5-second OFF	Outdoor unit does not run.	When the compressor operation is continuously three times interrupted by over current protection within 1 minute after start-up , it stops operation.	<ul style="list-style-type: none"> ● Check the inverter output. ● Check the compressor.
5	MUH or MXZ type Defrost thermistor	6-time flash 2.5-second OFF	Outdoor unit does not run.	When the defrost thermistor shorts or opens after the compressor start-up.	<ul style="list-style-type: none"> ● Check outdoor DEICER P.C. board and others. ● Check resistance of thermistor. ● Reconnect connector. Refer to service manual OB331 or OB319.
6	MUH or MXZ type Outdoor control system error	7-time flash 2.5-second OFF	Outdoor unit does not run.	When it cannot properly read data in the non-volatile memory of outdoor electronic control P.C. board.	<ul style="list-style-type: none"> ● Check outdoor DEICER P.C. board and others. Refer to service manual OB331 or OB319.
7	MXZ type Outdoor refrigerant system error	10-time flash 2.5-second OFF	Outdoor unit does not run.	When the compressor operation has been interrupted by LEV protection continuously 5 minutes, the compressor stops operation.	<ul style="list-style-type: none"> ● Refer to "Check of LEV". ● Check refrigerant circuit and refrigerant amount. ● Check outdoor electronic control P.C. board. Refer to service manual OB319.
8	MXZ type Operation mode setting	 2.5-second OFF	Outdoor unit operates but indoor unit does not run.	When the operation mode of each indoor unit is differently set to COOL(includes DRY) and HEAT at same time, the operation mode of indoor unit that has operated at first has the priority.	<ul style="list-style-type: none"> ● Unify the operation mode.

10-4. Trouble criterion of main parts

MSC-A07YV -E1

MSC-A09YV -E1

MSC-A12YV -E1

Part name	Check method and criterion	Figure											
Room temperature thermistor (RT11)	Measure the resistance with a tester. (Part temperature 10°C ~ 30°C)	/											
Indoor coil thermistor (RT12)													
Indoor fan motor (MF) INNER FUSE 136±3°C CUT OFF	Measure the resistance between the terminals with a tester. (Coil wiring temperature 10°C ~ 30°C)												
	<table border="1"> <thead> <tr> <th rowspan="2">Color of lead wire</th> <th colspan="2">Normal</th> <th rowspan="2">Abnormal</th> </tr> <tr> <th>MSC-A07/A09YV</th> <th>MSC-A12YV</th> </tr> </thead> <tbody> <tr> <td>WHT-BLK</td> <td>396 ~ 430Ω</td> <td>303 ~ 329Ω</td> <td rowspan="2">Open or short-circuit</td> </tr> <tr> <td>BLK-RED</td> <td>320 ~ 348Ω</td> <td>287 ~ 311Ω</td> </tr> </tbody> </table>		Color of lead wire	Normal		Abnormal	MSC-A07/A09YV	MSC-A12YV	WHT-BLK	396 ~ 430Ω	303 ~ 329Ω	Open or short-circuit	BLK-RED
Color of lead wire	Normal			Abnormal									
	MSC-A07/A09YV	MSC-A12YV											
WHT-BLK	396 ~ 430Ω	303 ~ 329Ω	Open or short-circuit										
BLK-RED	320 ~ 348Ω	287 ~ 311Ω											
Vane motor (MV)	Measure the voltage Power ON.												
	<table border="1"> <thead> <tr> <th rowspan="2">Color of lead wire</th> <th>Normal</th> <th rowspan="2">Abnormal</th> </tr> <tr> <th>MSC-A07/A09/A12YV</th> </tr> </thead> <tbody> <tr> <td>BRN-YLW</td> <td>4.5 ~ 5.5V</td> <td rowspan="2">Remain 0V or 5V</td> </tr> <tr> <td>YLW-GRY</td> <td>(When fan revolved one time) 0V→5V→0V (Approx.)</td> </tr> </tbody> </table>		Color of lead wire	Normal	Abnormal	MSC-A07/A09/A12YV	BRN-YLW	4.5 ~ 5.5V	Remain 0V or 5V	YLW-GRY	(When fan revolved one time) 0V→5V→0V (Approx.)		
Color of lead wire	Normal	Abnormal											
	MSC-A07/A09/A12YV												
BRN-YLW	4.5 ~ 5.5V	Remain 0V or 5V											
YLW-GRY	(When fan revolved one time) 0V→5V→0V (Approx.)												
Vane motor (MV)	Measure the resistance between the terminals with a tester. (Part temperature 10°C ~ 30°C)												
	<table border="1"> <thead> <tr> <th>Normal</th> <th>Abnormal</th> </tr> </thead> <tbody> <tr> <td>MSC-A07/A09/A12YV</td> <td rowspan="2">Open or short-circuit</td> </tr> <tr> <td>240 ~ 260Ω</td> </tr> </tbody> </table>		Normal	Abnormal	MSC-A07/A09/A12YV	Open or short-circuit	240 ~ 260Ω						
Normal	Abnormal												
MSC-A07/A09/A12YV	Open or short-circuit												
240 ~ 260Ω													

When OPERATION INDICATOR lamp flashes 3-time.
Indoor fan motor doesn't operate.

A Check of indoor fan motor

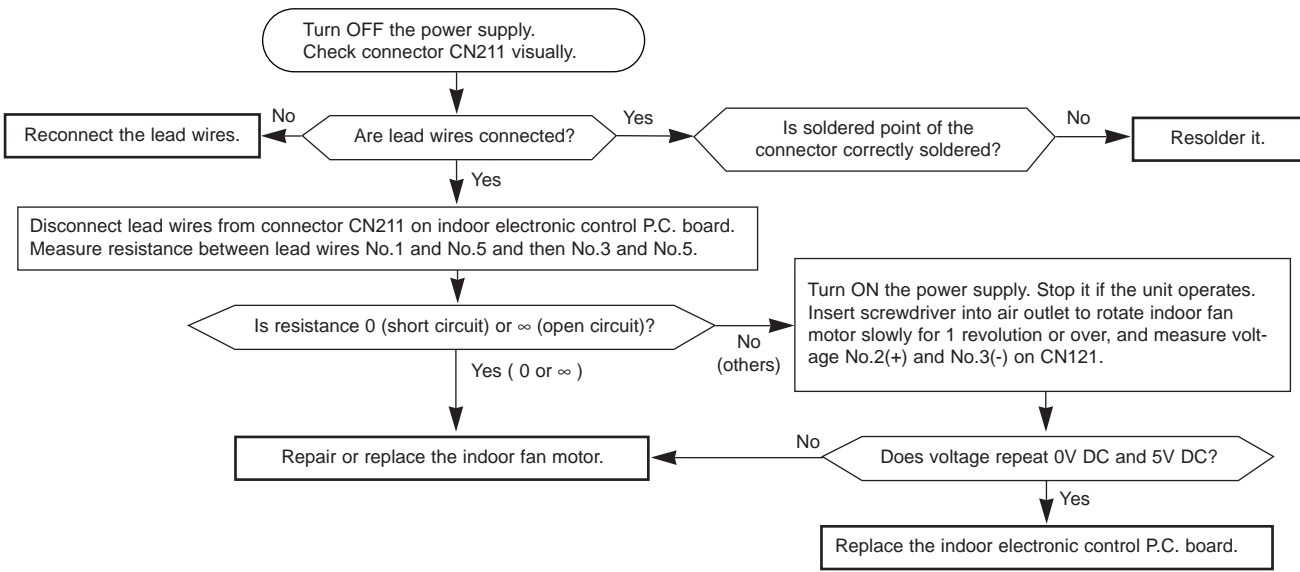

Indoor unit operates by pressing the EMERGENCY OPERATION switch, but doesn't operate with the remote controller.

Ⓑ Check of remote controller and receiver P.C. board

※Check the remote controller is exclusive for this air conditioner.

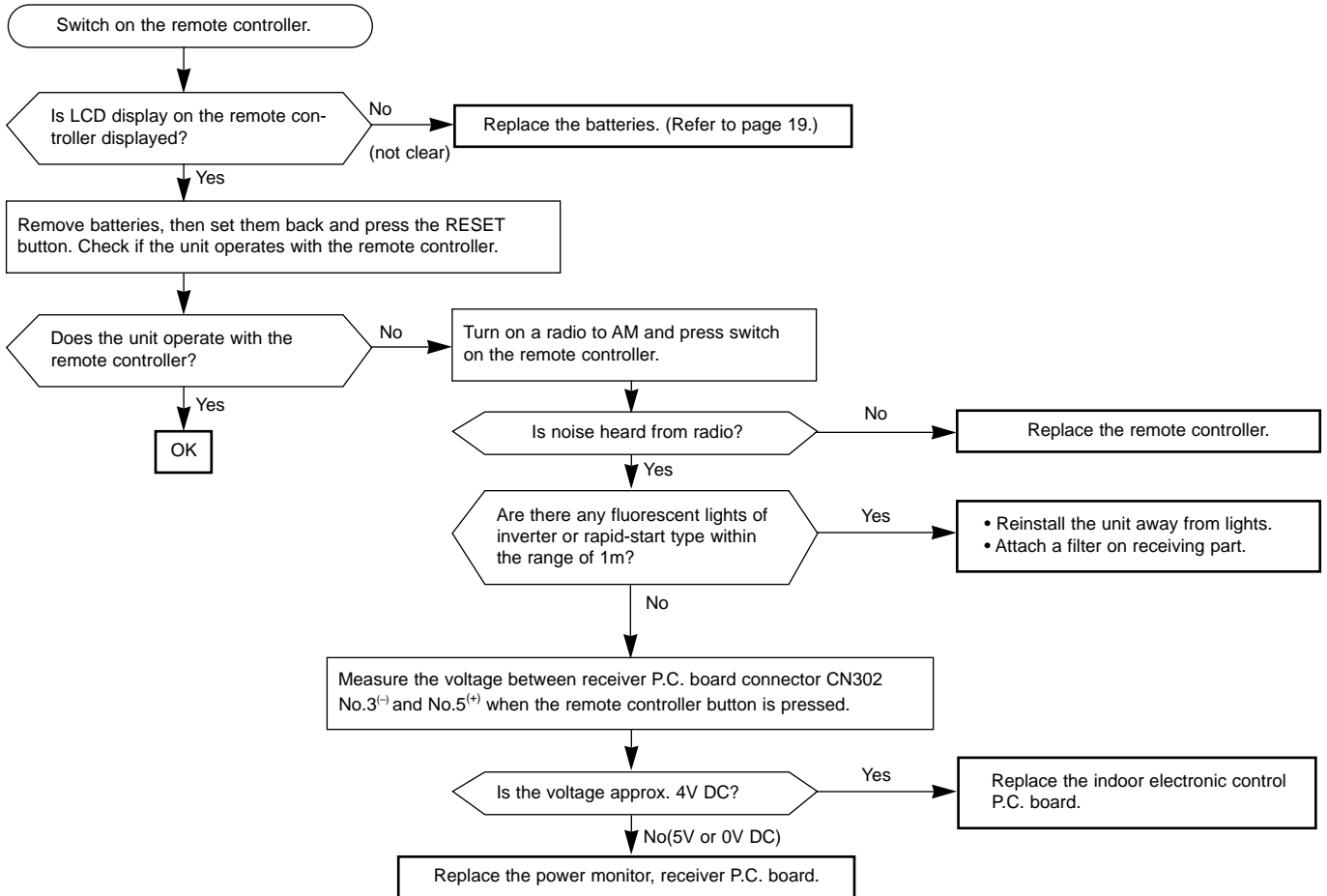

The unit doesn't operate with the remote controller.

Also, the OPERATION INDICATOR lamp doesn't light up by pressing the EMERGENCY OPERATION switch.

Ⓒ Check of indoor electronic control P.C. board

Check the both "parts side" and "pattern side" of indoor electronic control P.C. board visually.

Turn OFF the power supply. Remove indoor fan motor connector CN211 and vane motor connector CN151 from the indoor electronic control P.C. board and turn ON the power supply.

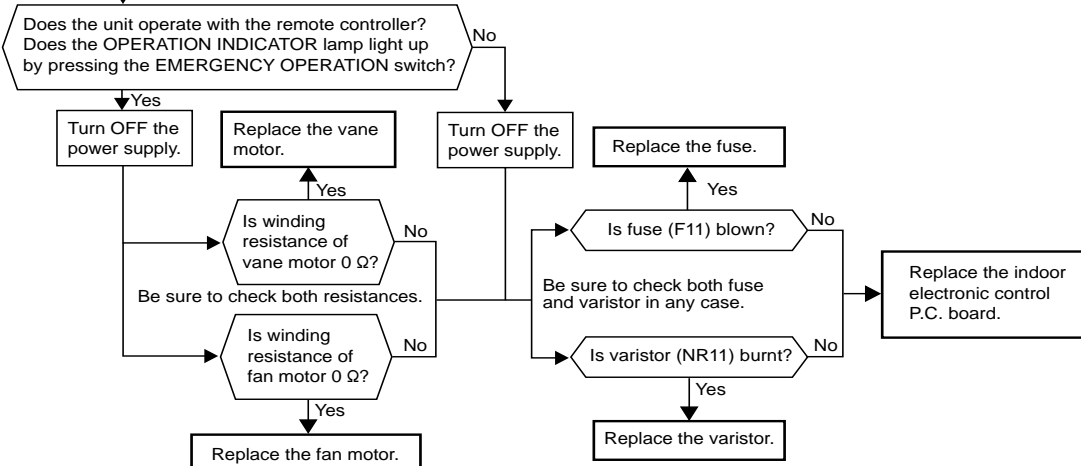

When OPERATION INDICATOR lamp flashes 0.5-second intervals or 1-time.
Outdoor unit does not operate.

③ How to check mis-wiring and serial signal error

<MUH-A07/A09/A12YV, MXZ-A18/A26/A32WV>

- ※ 1 Set the switch(SW2-②) on indoor electronic control P.C. board to MU or MUX type, when the outdoor unit is MU or MUX type. If the setting is MUH or MXZ type, the unit does not work.
- ※ 2 Short circuit of JPG and JPS on the indoor electronic control P.C. board enables self-check to be displayed in 3 seconds.

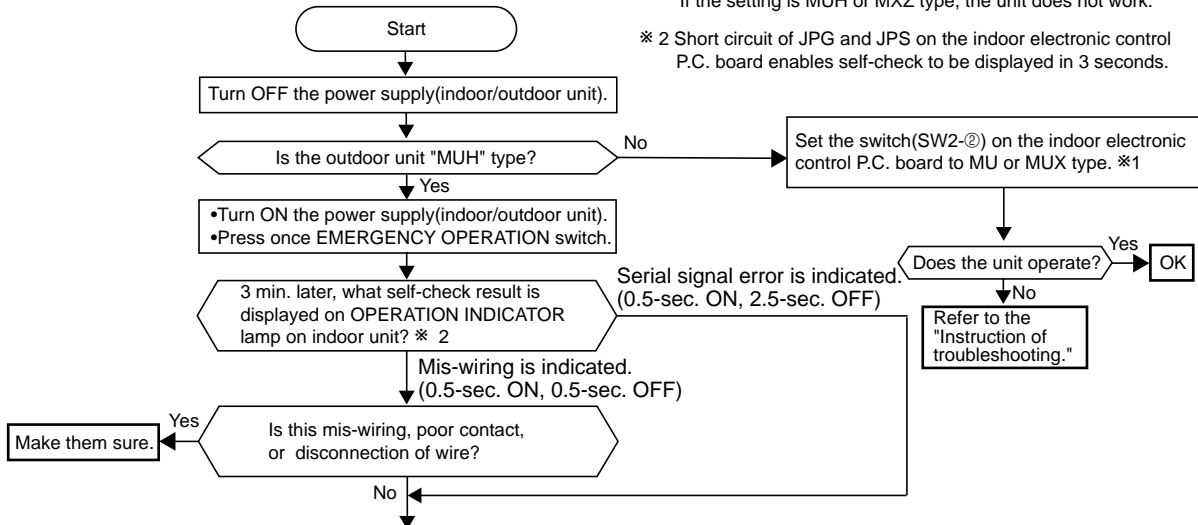

1. Turn OFF the power supply(indoor / outdoor unit) and disconnect indoor and outdoor connecting wire on indoor side.
2. Short-circuit between indoor terminal block ② and ③.
3. Turn ON the power supply(indoor unit) and press once EMERGENCY OPERATION switch.

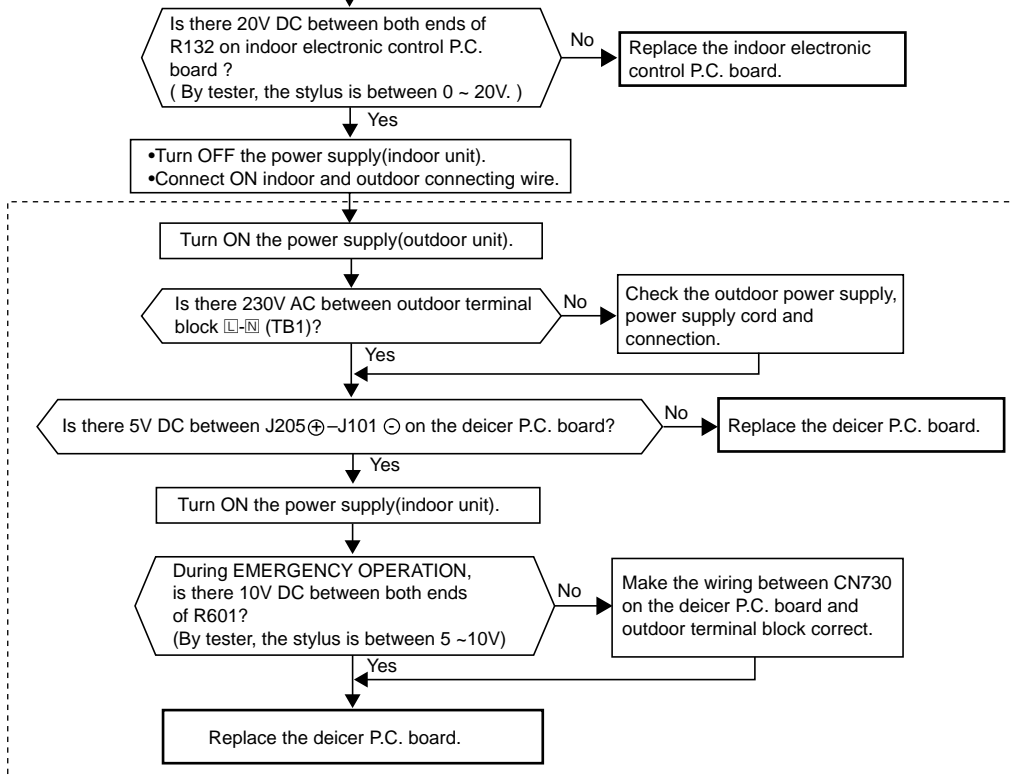

As for outdoor unit MUH type, refer to service manual OB331.
As for outdoor unit MXZ type, refer to service manual OB319.

TEST POINT DIAGRAM AND VOLTAGE

MSC-A07YV -E1

MSC-A09YV -E1

MSC-A12YV -E1

Indoor electronic control P.C. board

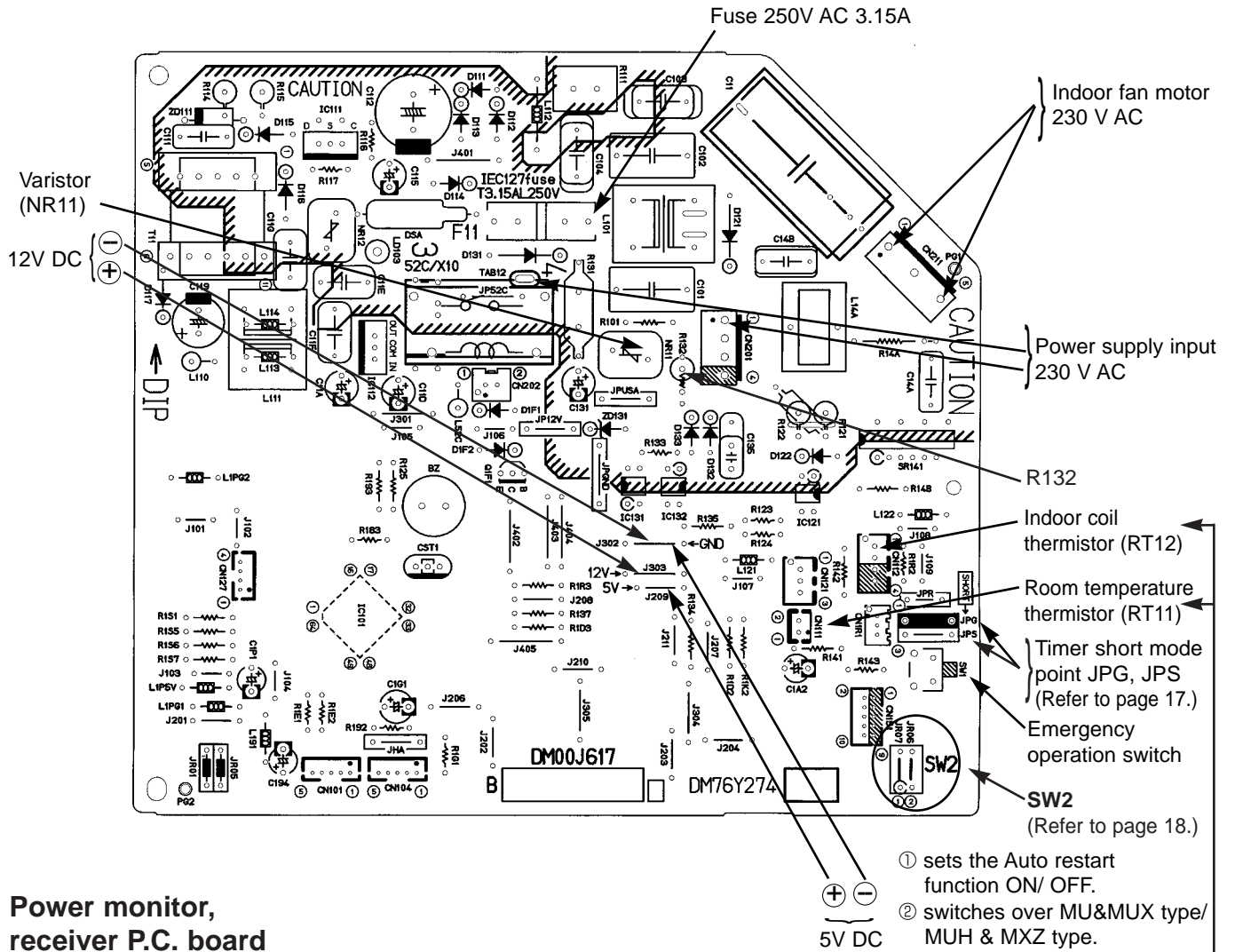

Power monitor, receiver P.C. board

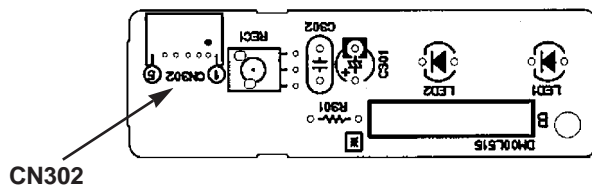

Indoor coil thermistor (RT12)
Room temperature thermistor (RT11)

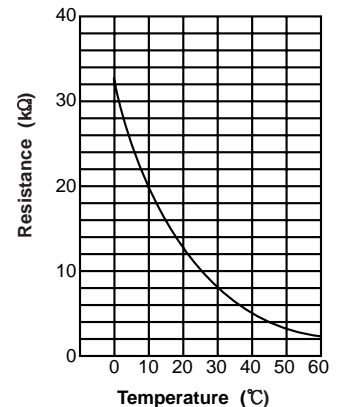

<"Terminal with lock mechanism" Detaching points>

In case of terminal with lock mechanism, detach the terminal as shown below.
There are two types (Refer to (1) and (2)) of the terminal with lock mechanism.
The terminal with no lock mechanism can be removed by pulling it out.
Check the shape of the terminal and work.

(1) Slide the sleeve and check if there is a locking lever or not.

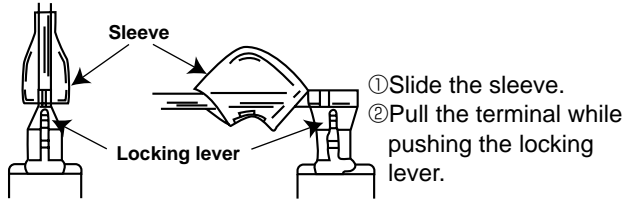

(2) The terminal with this connector is a terminal with lock mechanism

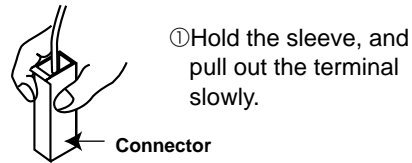

MSC-A07YV -E1 MSC-A09YV -E1 MSC-A12YV -E1
INDOOR UNIT

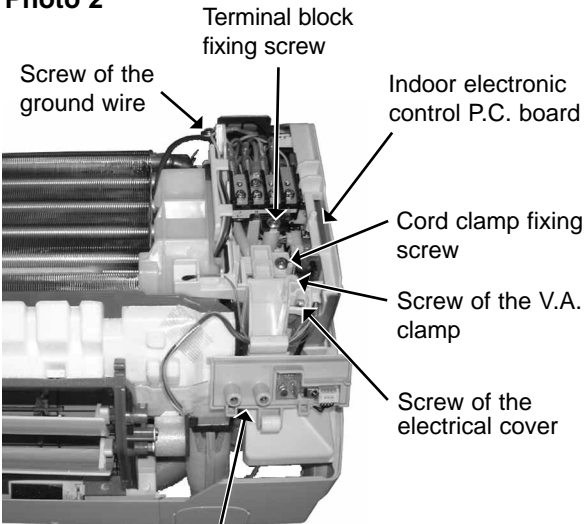
OPERATING PROCEDURE	PHOTOS
<p>1. Removing the front panel</p> <p>(1) Remove the screw caps of the front panel. Remove the screws.</p> <p>(2) Pull the panel down to your side slightly and unhook the catches at the top.</p>	<p>Photo 1</p>  <p>Screws of the front panel</p>
<p>2. Removing the electronic control P.C. board and the power monitor, receiver P.C. board</p> <p>NOTE : In case of removing only indoor electronic control P.C. board, work (3) is not necessary.</p> <p>(1) Remove the front panel. (Refer to 1.)</p> <p>(2) Remove the power monitor, receiver P.C. board holder from the bottom of electrical box.</p> <p>(3) Open the power monitor, receiver P.C. board holder and remove the power monitor, receiver P.C. board.</p> <p>(4) Remove the screw of the electrical cover and the electrical cover.</p> <p>(5) Remove the screw of the V.A. clamp and the V.A. clamp.</p> <p>(6) Remove the screw of the cord clamp and the cord clamp.</p> <p>(7) Remove the screw of the terminal block.</p> <p>(8) Remove the screw of the ground wire.</p> <p>(9) Pull out indoor electronic control P.C. board slightly.</p> <p>(10) Disconnect all (except CN101) the connectors on the electronic control P.C. board.</p> <p>(11) Remove the electronic control P.C. board.</p> <p>(12) Disconnect the connector of power monitor, receiver P.C. board (CN101) on the electronic control P.C. board.</p>	<p>Photo 2</p>  <p>Terminal block fixing screw</p> <p>Screw of the ground wire</p> <p>Indoor electronic control P.C. board</p> <p>Cord clamp fixing screw</p> <p>Screw of the V.A. clamp</p> <p>Screw of the electrical cover</p> <p>Power monitor, receiver P.C. board holder</p>



OPERATING PROCEDURE

3. Removing the electrical box

- (1) Remove the front panel. (Refer to 1.)
- (2) Remove the electrical cover. (Refer to 2.)
- (3) Remove the V.A. clamp. (Refer to 2.)
- (4) Remove the cord clamp. (Refer to 2.)
- (5) Remove the terminal block. (Refer to 2.)
- (6) Remove the screw of ground wire. (Refer to 2.)
- (7) Disconnect the connector of the indoor coil thermistor (CN112), the fan motor connector (CN211 and CN121) and the vane motor connector (CN151) on the electronic control P.C. board.
- (8) Remove the fan motor lead wire and indoor coil thermistor from the electrical box.
- (9) Remove the lead wire of vane motor from the bottom of electrical box.
- (10) Remove the screw fixing the electrical box, remove the electrical box.

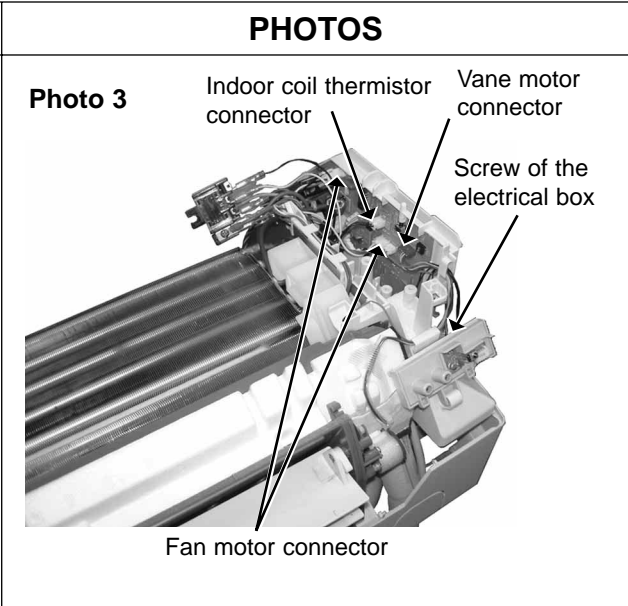

4. Removing the nozzle assembly and the vane motor

- (1) Remove the front panel. (Refer to 1.)
- (2) Remove the electrical box. (Refer to 3.)
- (3) Pull out the drain hose from the nozzle assembly, remove the nozzle assembly.
- (4) Remove the screws of the vane motor, disconnect the vane motor connector.
- (5) Remove the vane motor.

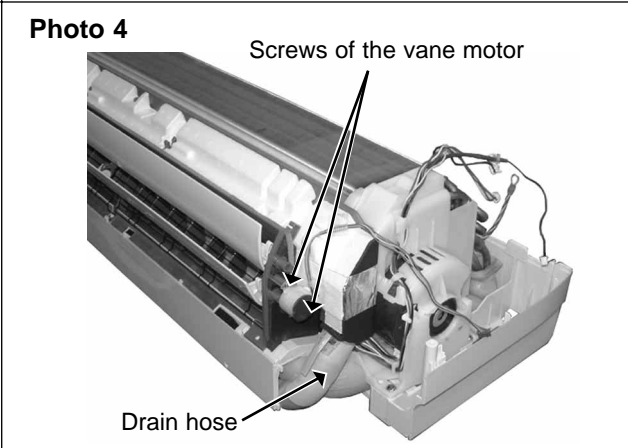

5. Removing the indoor fan motor and the line flow fan

- (1) Remove the front panel. (Refer to 1.)
- (2) Remove the electrical box. (Refer to 3.)
- (3) Pull out the drain hose from the nozzle assembly, remove the nozzle assembly. (Refer to 4.)
- (4) Remove the screw of the lead cover and lead cover.
- (5) Release the hooks to open the motor band slightly.
- (6) Loosen the hexagon socket set screw from the line flow fan.
- (7) Remove the screws fixing the motor bed, remove the fan motor with motor band and the motor bed.
- (8) Remove the screws fixing the left side of the heat exchanger.
- (9) Lift the left side of the heat exchanger.
- (10) Remove the line flow fan.

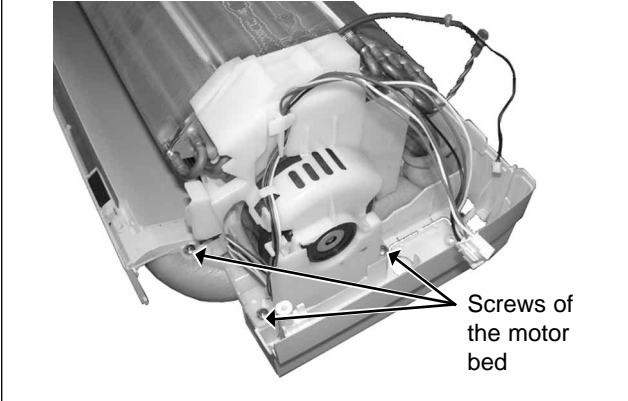
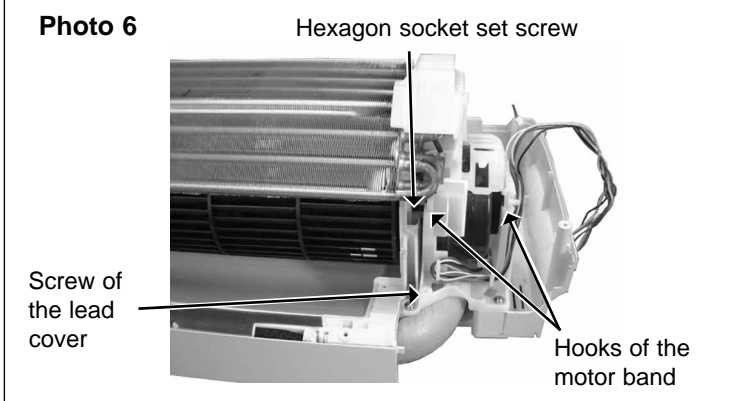
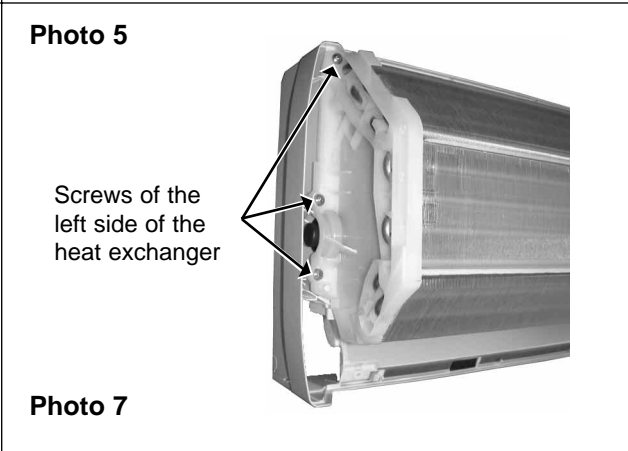

MSC-A07YV -E1 (WH)
 MSC-A09YV -E1 (WH)
 MSC-A12YV -E1 (WH)

12-1. INDOOR UNIT STRUCTURAL PARTS

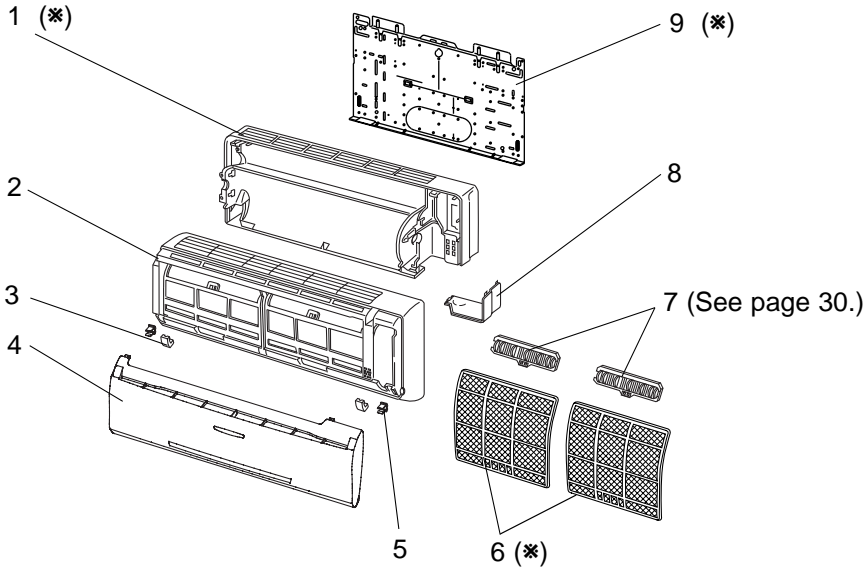

12-2. ACCESSORY AND REMOTE CONTROLLER

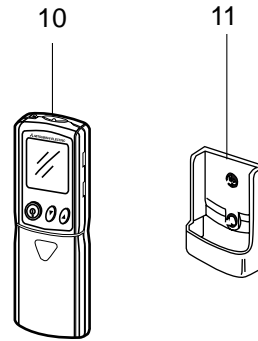

(*) These figures show about MSC-A12YV.

12-1. INDOOR UNIT STRUCTURAL PARTS

No.	Part No.	Part Name	Symbol in Wiring Diagram	Q'ty/unit			Remarks
				MSC-A07YV-E1 (WH)	MSC-A09YV-E1 (WH)	MSC-A12YV-E1 (WH)	
1	E02 749 234	BOX(WH)		1	1		
	E02 751 234	BOX(WH)				1	
2	E02 829 000	PANEL ASSEMBLY(WH)		1	1	1	Including No.3,4,5
3	E02 749 067	SCREW CAP(WH)		2	2	2	2PCS/SET
4	E02 829 010	FRONT PANEL(WH)		1	1	1	
5	E02 408 142	CATCH		2	2	2	2PCS/SET
6	E02 763 100	CATECHIN AIR FILTER		2	2		
	E02 764 100	CATECHIN AIR FILTER				2	
7		AIR CLEANING FILTER		2	2	2	MAC-1300FT
8	E02 749 975	CORNER BOX (RIGHT)		1	1	1	
9	E02 408 970	INSTALLATION PLATE		1	1		
	E02 751 970	INSTALLATION PLATE				1	

12-2. ACCESSORY AND REMOTE CONTROLLER

10	E02 749 426	REMOTE CONTROLLER		1	1	1	
11	E02 527 083	REMOTE CONTROLLER HOLDER		1	1	1	

MSC-A07YV -^[E1] (WH) MSC-A09YV -^[E1] (WH) MSC-A12YV -^[E1] (WH)

12-3. INDOOR UNIT ELECTRICAL PARTS AND FUNCTIONAL PARTS

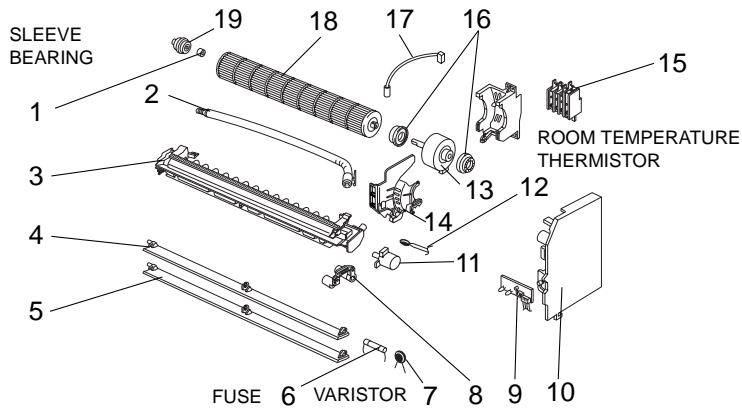

12-4. INDOOR UNIT HEAT EXCHANGER

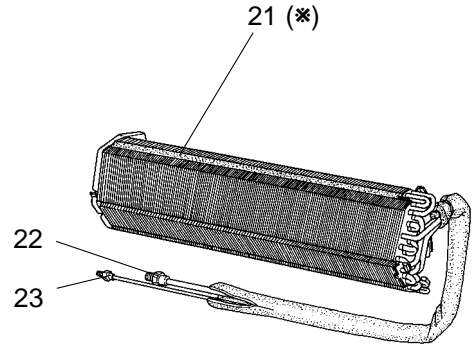

(*) This figure shows about MSC-A12YV.

12-3. INDOOR UNIT ELECTRICAL PARTS AND FUNCTIONAL PARTS

Part number that is circled is not shown in the illustration.

No.	Part No.	Part Name	Symbol in Wiring Diagram	Q'ty/unit			Remarks
				MSC-A07YV- ^[E1] (WH)	MSC-A09YV- ^[E1] (WH)	MSC-A12YV- ^[E1] (WH)	
1	E02 001 504	SLEEVE BEARING		1	1	1	
2	E02 661 702	DRAIN HOSE		1	1	1	
3	E02 749 235	NOZZLE ASSEMBLY(WH)		1	1	1	
4	E02 749 040	VANE UPPER (WH)		1	1	1	
5	E02 749 041	VANE LOWER (WH)		1	1	1	
6	E02 127 382	FUSE	F11	1	1	1	3.15A
7	E02 829 385	VARISTOR	NR11	1	1	1	
8	E02 763 034	VANE CRANK SET		1	1	1	
9	E02 749 468	POWER MONITOR, RECEIVER P.C. BOARD		1	1	1	
10	E02 829 452	ELECTRONIC CONTROL P.C.BOARD		1			AUTO RESTART
	E02 830 452	ELECTRONIC CONTROL P.C.BOARD			1		AUTO RESTART
	E02 831 452	ELECTRONIC CONTROL P.C.BOARD				1	AUTO RESTART
11	E02 749 303	VANE MOTOR	MV	1	1	1	
12	E02 151 308	ROOM TEMPERATURE THERMISTOR	RT11	1	1	1	
13	E02 749 300	INDOOR FAN MOTOR	MF	1	1		RC4V19-□□
	E02 751 300	INDOOR FAN MOTOR	MF			1	RC4V19-□□
14	E02 749 333	MOTOR BAND		1	1	1	
15	E02 691 375	TERMINAL BLOCK	TB	1	1	1	
16	E02 665 505	FAN MOTOR RUBBER MOUNT		2	2		2PCS/SET
	E02 151 505	FAN MOTOR RUBBER MOUNT				2	2PCS/SET
17	E02 749 307	INDOOR COIL THERMISTOR	RT12	1	1	1	
18	E02 749 302	LINE FLOW FAN		1	1	1	
19	E02 408 509	BEARING MOUNT		1	1		
	E02 751 509	BEARING MOUNT				1	
20	E02 749 385	VARISTOR	NR12	1	1	1	

12-4. INDOOR UNIT HEAT EXCHANGER

21	E02 749 620	INDOOR HEAT EXCHANGER		1	1		
	E02 751 620	INDOOR HEAT EXCHANGER				1	
22	E02 151 666	UNION(GAS)		1	1		φ9.52
	E02 155 666	UNION(GAS)				1	φ12.7
23	E02 151 667	UNION(LIQUID)		1	1	1	φ6.35

12-5. AIR CLEANING FILTER

- AIR CLEANING FILTER removes fine dust of 0.01 micron from air by means of static electricity.
- Normal life of AIR CLEANING FILTER is 4 months. However, when it becomes dirty, replace it as soon as possible.
- Clogged AIR CLEANING FILTER may reduce the air conditioner capacity or cause frost on the air outlet.
- DO NOT reuse AIR CLEANING FILTER even if it is washed.
- DO NOT remove or attach AIR CLEANING FILTER during unit operation.

Model	Part No.
MSC-A07YV- E1	MAC-1300FT
MSC-A09YV- E1	
MSC-A12YV- E1	

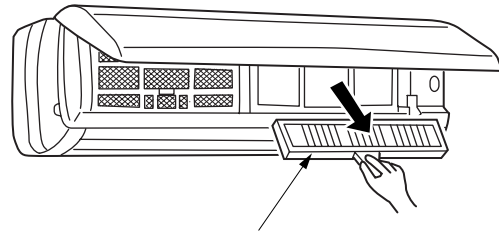

**Air cleaning filter
(White bellows type)**



HEAD OFFICE: MITSUBISHI DENKI BLDG.,2-2-3, MARUNOUCHI, CHIYODA-KU, TOKYO100-8310, JAPAN

© Copyright 2003 MITSUBISHI ELECTRIC ENGINEERING CO.,LTD
Distributed in Dec. 2003. No.OB329 6
Made in Japan

New publication, effective Dec. 2003
Specifications subject to change without notice.