

Revision A:

- Resistance of LEV (Expansion valve) has been modified.
- Power input and others have been added to SPECIFICATION.

Please void OB326.

SERVICE MANUAL



No. OB326
REVISED EDITION-A

Wireless type Models

- MU-A18WV** - E1
- MU-A24WV** - E1
- MU-A30WV** - E1

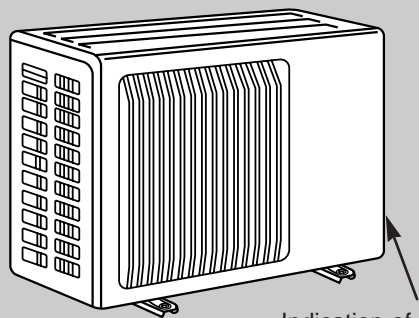

Indication of model name
MU-A18WV - E1

CONTENTS

1. TECHNICAL CHANGES	2
2. PART NAMES AND FUNCTIONS.....	5
3. SPECIFICATION.....	5
4. NOISE CRITERIA CURVES	7
5. OUTLINES AND DIMENSIONS	8
6. WIRING DIAGRAM	9
7. REFRIGERANT SYSTEM DIAGRAM	11
8. PERFORMANCE CURVES	14
9. MICROPROCESSOR CONTROL	22
10. TROUBLESHOOTING.....	25
11. DISASSEMBLY INSTRUCTIONS.....	32
12. PARTS LIST.....	38

NOTE:

- This service manual describes technical data of outdoor units.
As for indoor units MS-A18WV-[E1], MS-A24WV-[E1] and MS-A30WV-[E1], refer to the service manual OB325.



Revision A:

- Resistance of LEV (Expansion valve) has been modified. (30.3 Ω ~ 37.0 Ω→41.0 Ω ~ 49.0 Ω)
TROUBLESHOOTING has been partially modified.
- Running current, power input and power factor have been added.
SPECIFICATION has been partially modified.

1 TECHNICAL CHANGES

MU-18RV -[E1]→MU-A18WV -[E1]

1. Refrigerant has changed. (R22→R410A)
2. Refrigerant system diagram has changed.
 - Diameter of stop valve has changed. (Gas: φ15.88→φ12.7)
 - Accumulator has removed.
3. Oil separator has been added.
4. Compressor has changed. (PH33VPET→RN196VHSHT)

MU-24RV -[E1]→MU-A24WV -[E1]

1. Refrigerant has changed. (R22→R410A)
2. Refrigerant system diagram has changed.
 - Diameter of stop valve has changed.
(Liquid: φ9.52→φ6.35)
3. Compressor has changed. (NH47VMDT→NN29VBAHT)

MU-30RV -[E1]→MU-A30WV -[E1]

1. Outdoor model has changed.
2. Refrigerant has changed. (R22→R410A)
3. Refrigerant system diagram has changed.
 - Accumulator has removed.
4. Compressor has changed. (NH56VNHT→NN37VAAHT)

INFORMATION FOR THE AIR CONDITIONER WITH R410A REFRIGERANT

- This room air conditioner adopts an HFC refrigerant (R410A) which never destroys the ozone layer.
 - Pay particular attention to the following points, though the basic installation procedure is same as that for R22 conditioners.
- ① As R410A has working pressure approximate 1.6 times as high as that of R22, some special tools and piping parts/materials are required. Refer to the table below.
 - ② Take sufficient care not to allow water and other contaminations to enter the R410A refrigerant during storage and installation, since it is more susceptible to contaminations than R22.
 - ③ For refrigerant piping, use clean, pressure-proof parts/materials specifically designed for R410A. (Refer to 2. Refrigerant piping.)
 - ④ Composition change may occur in R410A since it is a mixed refrigerant. When charging, charge liquid refrigerant to prevent composition change.

		New refrigerant	Previous refrigerant
Refrigerant	Refrigerant	R410A	R22
	Composition (Ratio)	HFC-32: HFC-125 (50%:50%)	R22 (100%)
	Refrigerant handling	Pseudo-azeotropic refrigerant	Single refrigerant
	Chlorine	Not included	Included
	Safety group (ASHRAE)	A1/A1	A1
	Molecular weight	72.6	86.5
	Boiling point (°C)	-51.4	-40.8
	Steam pressure [25°C](Mpa)	1.557	0.94
	Saturated steam density [25°C](Kg/m³)	64	44.4
	Combustibility	Non combustible	Non combustible
	ODP ※1	0	0.055
	GWP ※2	1730	1700
	Refrigerant charge method	From liquid phase in cylinder	Gas phase
	Additional charge on leakage	Possible	Possible
Refrigerating oil	Kind	Incompatible oil	Compatible oil
	Color	Non	Light yellow
	Smell	Non	Non

※1 :Ozone Destruction Parameter : based on CFC-11

※2 :Global Warmth Parameter : based on CO₂



	New Specification	Current Specification
Compressor	<p>The incompatible refrigerating oil easily separates from refrigerant and is in the upper layer inside the suction muffler. Raising position of the oil back hole enables to back the refrigerating oil of the upper layer to flow back to the compressor.</p>	<p>Since refrigerant and refrigerating oil are compatible each, refrigerating oil backs to the compressor through the lower position oil back hole.</p>

NOTE : The unit of pressure has been changed to MPa on the international system of units(SI unit system).
 The conversion factor is: **1(MPa [Gauge]) =10.2(kgf/cm² [Gauge])**

Conversion chart of refrigerant temperature and pressure

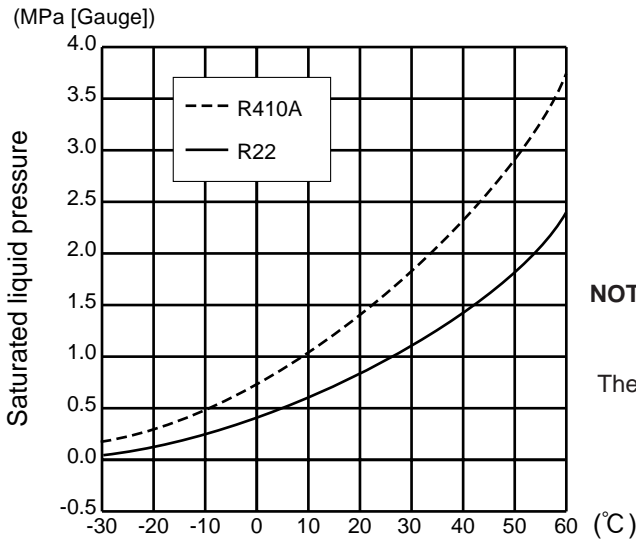

NOTE : The unit of pressure has been changed to MPa on the international system of units(SI unit system).
 The conversion factor is: **1(MPa [Gauge]) =10.2(kgf/cm² [Gauge])**

1.Tools dedicated for the air conditioner with R410A refrigerant

The following tools are required for R410A refrigerant. Some R22 tools can be substituted for R410A tools. The diameter of the service port on the stop valve in outdoor unit has been changed to prevent any other refrigerant being charged into the unit. Cap size has been changed from 7/16 UNF with 20 threads to 1/2 UNF with 20 threads.

R410A tools	Can R22 tools be used?	Description
Gauge manifold	No	R410A has high pressures beyond the measurement range of existing gauges. Port diameters have been changed to prevent any other refrigerant from being charged into the unit.
Charge hose	No	Hose material and cap size have been changed to improve the pressure resistance.
Gas leak detector	No	Dedicated for HFC refrigerant.
Torque wrench	Yes	6.35 mm and 9.52 mm
	No	12.7 mm and 15.88 mm
Flare tool	Yes	Clamp bar hole has been enlarged to reinforce the spring strength in the tool.
Flare gauge	New	Provided for flaring work (to be used with R22 flare tool).
Vacuum pump adapter	New	Provided to prevent the back flow of oil. This adapter enables you to use vacuum pumps.
Electronic scale for refrigerant charging	New	It is difficult to measure R410A with a charging cylinder because the refrigerant bubbles due to high pressure and high-speed vaporization

No : Not Substitutable for R410A Yes : Substitutable for R410A

2.Refrigerant piping

① Specifications

Use the refrigerant pipes that meet the following specifications.

Pipe	Outside diameter	Wall thickness	Insulation material
	mm		
For liquid	6.35	0.8 mm	Heat resisting foam plastic Specific gravity 0.045 Thickness 8 mm
	9.52	0.8 mm	
For gas	12.7	0.8 mm	
	15.88	1.0 mm	

- Use a copper pipe or a copper-alloy seamless pipe with a thickness of 0.8 mm (6.35, 9.52, 12.7), 1.0 mm (15.88). Never use any pipe with a thickness less than 0.8 mm (6.35, 9.52, 12.7), 1.0 mm (15.88), as the pressure resistance is insufficient.

② Flaring work and flare nut

Flaring work for R410A pipe differs from that for R22 pipe.

For details of flaring work, refer to Installation manual "FLARING WORK".

Pipe diameter	Dimension of flare nut	
	R410A	R22
mm		
6.35	17	17
9.52	22	22
12.7	26	24
15.88	29	27

3.Refrigerant oil

Apply the special refrigeration oil (accessories: packed with indoor unit) to the flare and the union seat surfaces.

4.Air purge

- Do not discharge the refrigerant into the atmosphere.
Take care not to discharge refrigerant into the atmosphere during installation, reinstallation, or repairs to the refrigerant circuit.
- Use the vacuum pump for air purging for the purpose of environmental protection.

5.Additional charge

For additional charging, charge the refrigerant from liquid phase of the gas cylinder.

If the refrigerant is charged from the gas phase, composition change may occur in the refrigerant inside the cylinder and the outdoor unit. In this case, ability of the refrigerating cycle decreases or normal operation can be impossible. However, charging the liquid refrigerant all at once may cause the compressor to be locked. Thus, charge the refrigerant slowly.

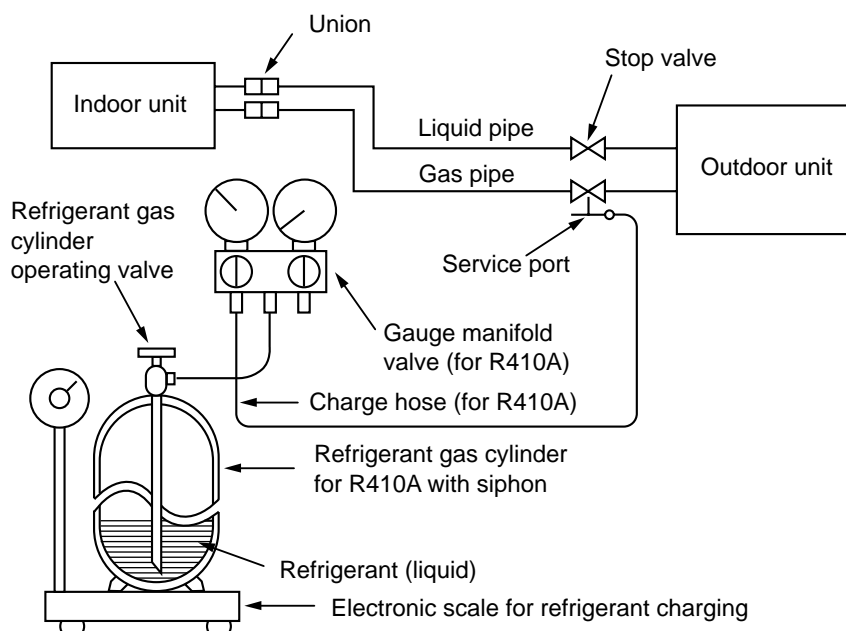

2

PART NAMES AND FUNCTIONS

OUTDOOR UNIT

MU-A18WV - E1

MU-A24WV - E1

MU-A30WV - E1

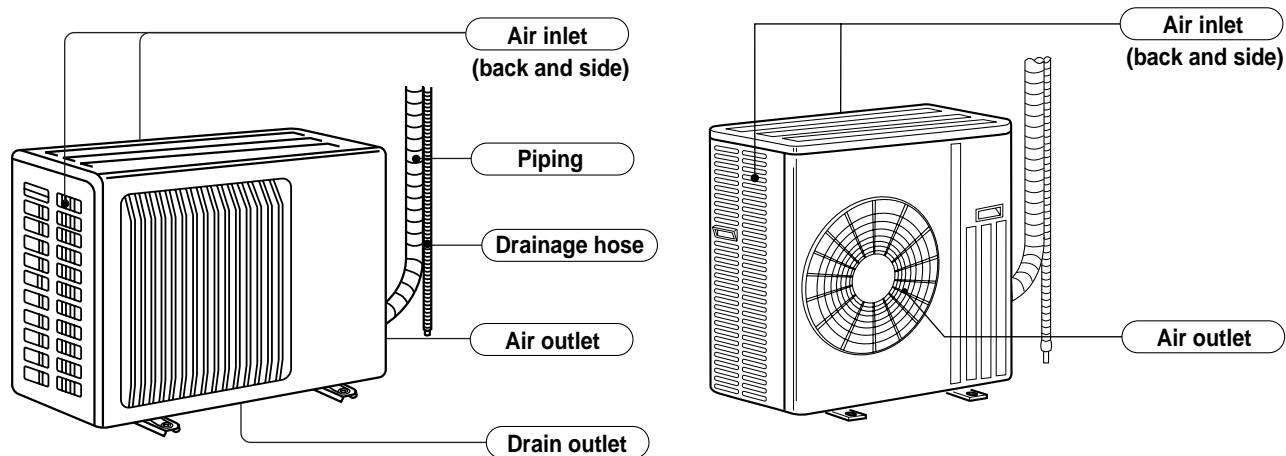

3

SPECIFICATION

Outdoor model			MU-A18WV - E1	MU-A24WV - E1	
Function			Cooling	Cooling	
Power supply			Single phase 230V, 50Hz	Single phase 230V, 50Hz	
Capacity	Capacity	kW	5.0	6.5	
	Dehumidification	ℓ /h	2.5	3.4	
	Air flow(High)	m ³ /h	2,196	2,322	
Electrical data	Power outlet	A	15	25	
	Running current	A	7.90	10.82	
	Power input	W	1,750	2,420	
	Power factor	%	96	97	
	Starting current	A	37	74	
	Compressor motor current	A	7.51	10.27	
	Fan motor current	A	0.39	0.55	
Coefficient of performance(C.O.P)			2.76	2.62	
Compressor	Model		RN196VHSHT	NN29VBAHT	
	Output	W	1,300	1,900	
	Winding resistance(at 20°C)	Ω	C-R 1.80 C-S 3.00	C-R 0.80 C-S 1.64	
Fan motor	Model		RA6V50-OG	RA6V60-MA	
	Winding resistance(at 20°C)	Ω	WHT-BLK 116 BLK-RED 111	WHT-BLK 71 BLK-RED 89	
Dimensions W×H×D			mm	850×605×290	
Weight			kg	44	
Special remarks	Sound level(High)	dB	52	53	
	Fan speed(High)	rpm	828	873	
	Fan speed regulator			1	1
	Refrigerant filling capacity(R410A)	kg	1.40	1.90	
	Refrigerating oil (Model)	cc	520 (NEO22)	1,200 (NEO22)	

NOTE: Test conditions are based on JIS C 9612.

Cooling : Indoor DB27°C WB19°C

Outdoor DB35°C WB(24°C)

Indoor-Outdoor piping length : 5m



Outdoor model			MU-A30WV - E1	
Function			Cooling	
Power supply			Single phase 230V, 50Hz	
Capacity	Capacity	kW	8.5	
	Dehumidification	ℓ /h	4.6	
	Air flow(High/Low*)	m ³ /h	2,940/1,470*	
Electrical data	Power outlet	A	25	
	Running current	A	14.42	
	Power input	W	3,191	
	Power factor	%	96	
	Starting current	A	90	
	Compressor motor current	A	13.85	
	Fan motor current	A	0.57	
Coefficient of performance(C.O.P)			2.61	
Compressor	Model		NN37VAAHT	
	Output	W	2,500	
	Winding resistance(at 20°C)	Ω	C-R 0.64 C-S 1.63	
Fan motor	Model		RA6V75-AB	
	Winding resistance(at 20°C)	Ω	WHT-BLK 62.8 BLK-YLW 55.9 YLW-RED 26.0	
Dimensions W×H×D		mm	840×850×330	
Weight		kg	75	
Special remarks	Sound level(High/Low*)	dB	55/53*	
	Fan speed(High/Low*)	rpm	805/435*	
	Fan speed regulator			2
	Refrigerant filling capacity(R410A)	kg	2.30	
	Refrigerating oil (Model)	cc	1,300 (NEO 22)	
	Thermistor RT62(at 25°C)	kΩ	231.44	
	Thermistor RT63(at 0°C)	kΩ	33.18	

NOTE: Test conditions are based on JIS C 9612.

Cooling : Indoor DB27°C WB19°C
Outdoor DB35°C WB(24°C)

Indoor-Outdoor piping length : 5m

* Reference value

4

NOISE CRITERIA CURVES

MU-A18WV-E1

FAN SPEED	SPL(dB(A))	LINE
High	52	● — ●

Test conditions,
Cooling : Dry-bulb temperature 35°C Wet-bulb temperature 24°C

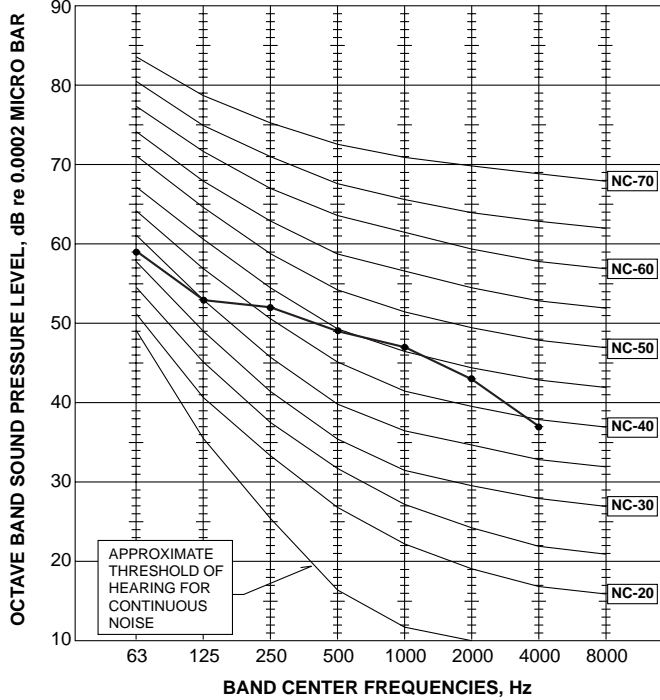

MU-A24WV-E1

FAN SPEED	SPL(dB(A))	LINE
High	53	● — ●

Test conditions,
Cooling : Dry-bulb temperature 35°C Wet-bulb temperature 24°C

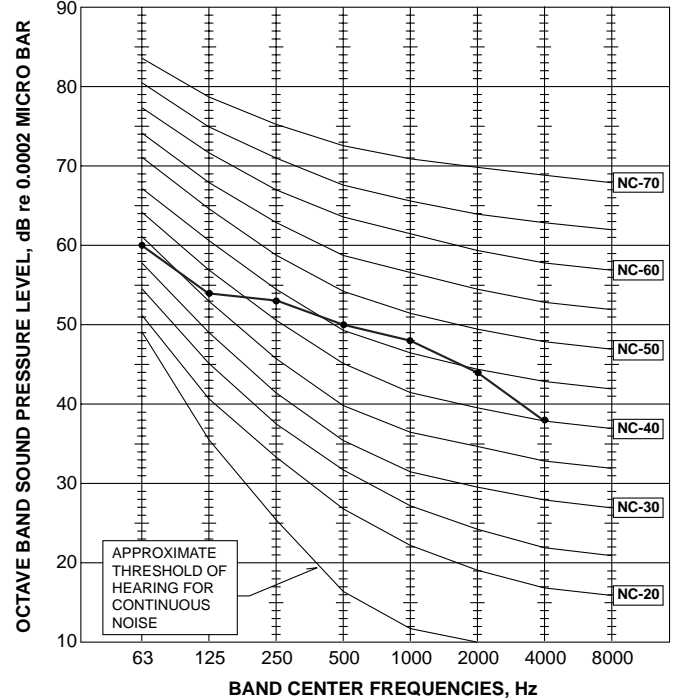

MU-A30WV-E1

FAN SPEED	SPL(dB(A))	LINE
High	55	● — ●

Test conditions,
Cooling : Dry-bulb temperature 35°C Wet-bulb temperature 24°C

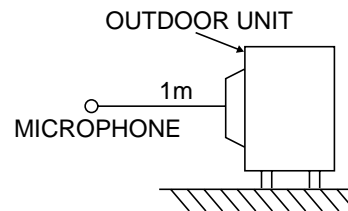
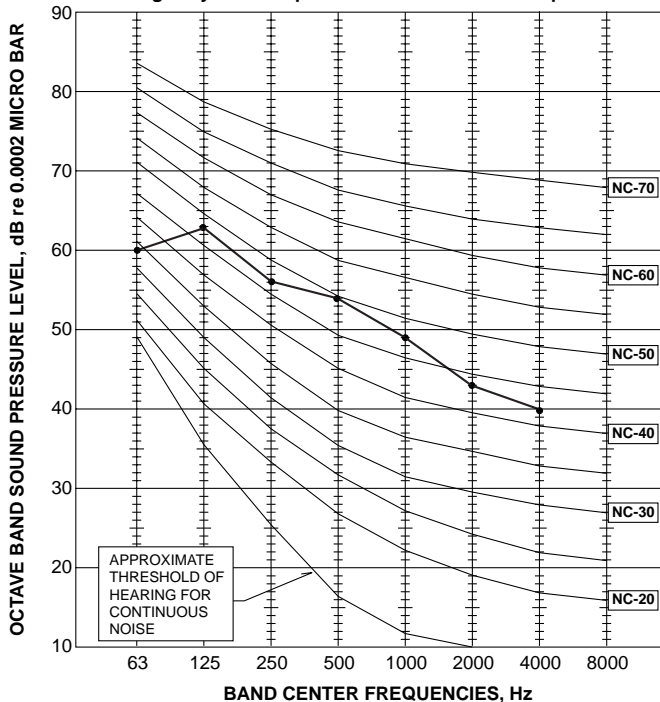

MU-A18WV-E1 MU-A24WV-E1

Unit: mm

OUTDOOR UNIT

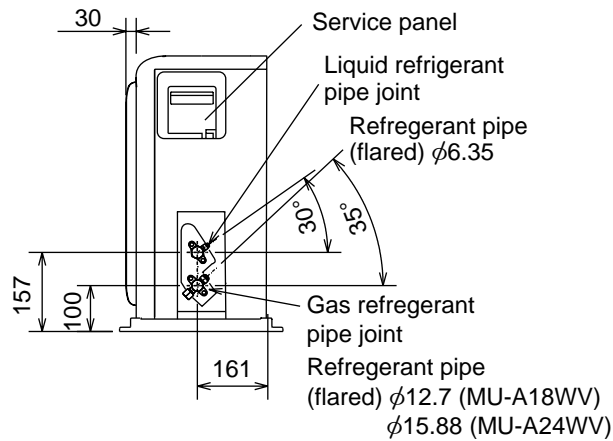
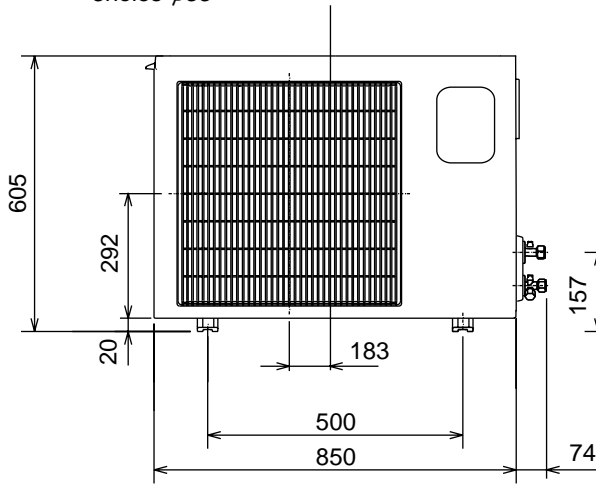
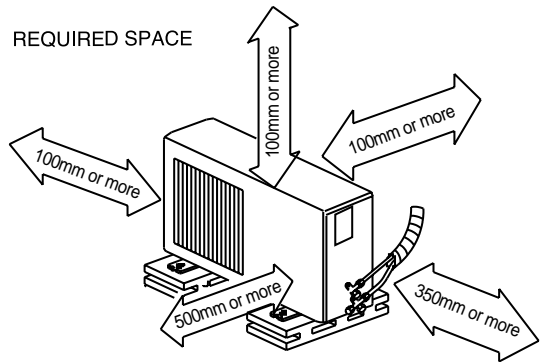
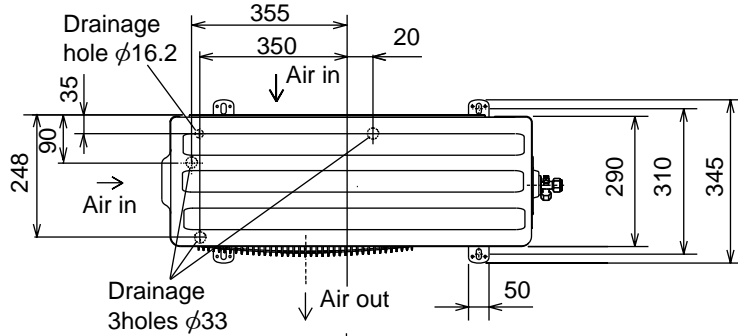

MU-A30WV-E1

OUTDOOR UNIT

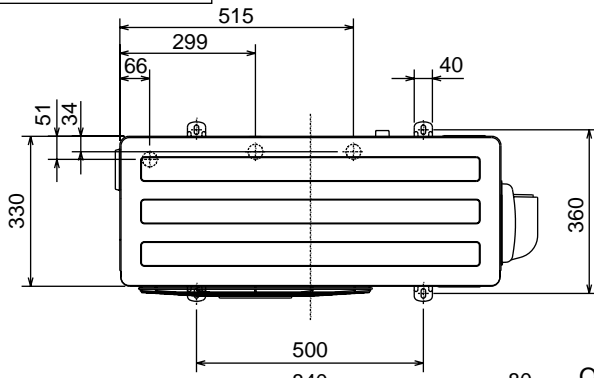

REQUIRED SPACE

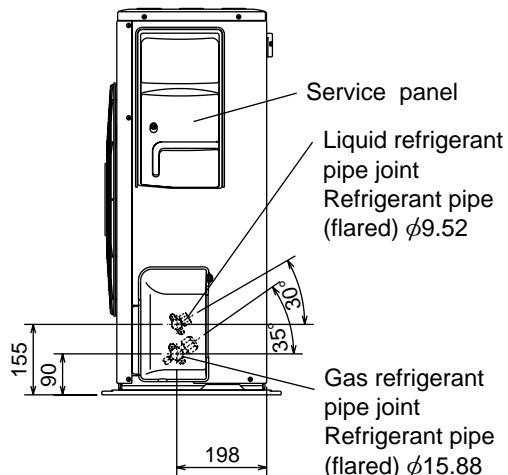
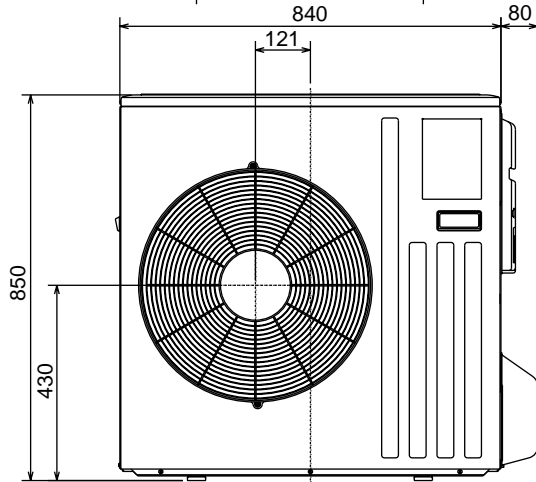
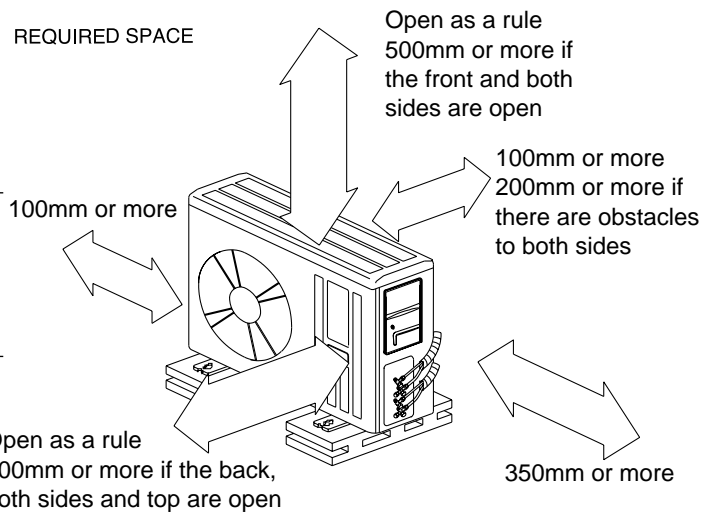

MU-A18WV -E1

MODEL WIRING DIAGRAM

OUTDOOR UNIT

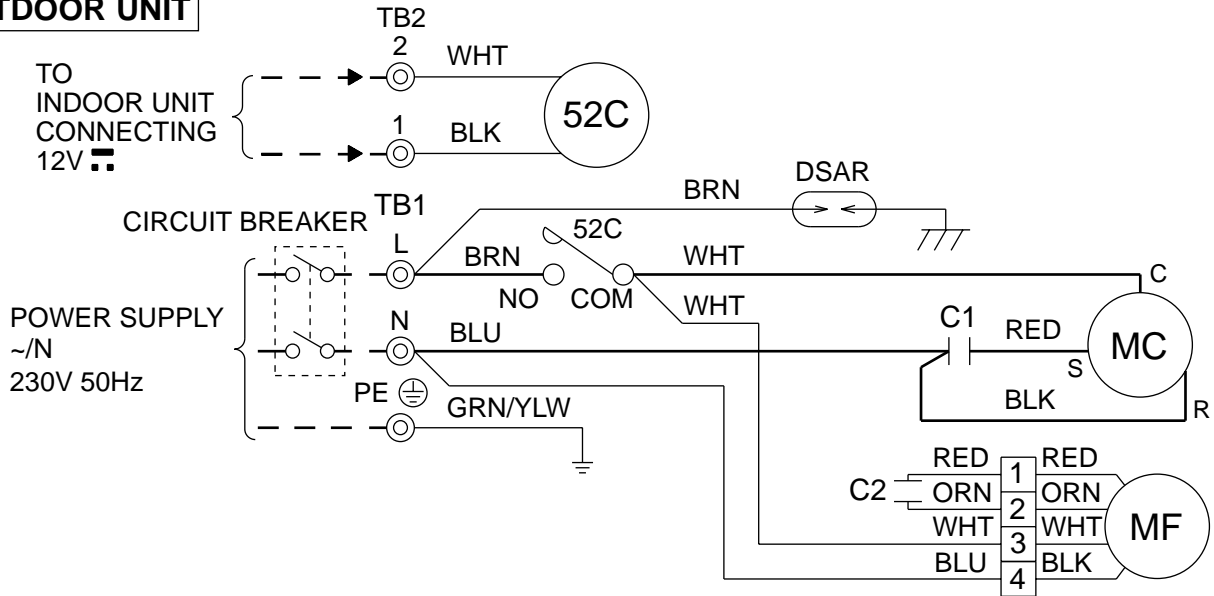

SYMBOL	NAME	SYMBOL	NAME	SYMBOL	NAME
C1	COMPRESSOR CAPACITOR	MC	COMPRESOR (INNER PROTECTOR)	52C	COMPRESSOR CONTACTOR
C2	OUTDOOR FAN CAPACITOR	MF	OUTDOOR FAN MOTOR (INNER PROTECTOR)		
DSAR	SURGE ABSORBER	TB1,TB2	TERMINAL BLOCK		

NOTES: 1.About the indoor side electric wiring refer to the indoor unit electric wiring diagram for servicing.
 2.Use copper conductors only. (For field wiring)
 3.Symbols below indicate.

⊙ : Terminal block □□□□ : Connector

MU-A24WV -E1

MODEL WIRING DIAGRAM

OUTDOOR UNIT

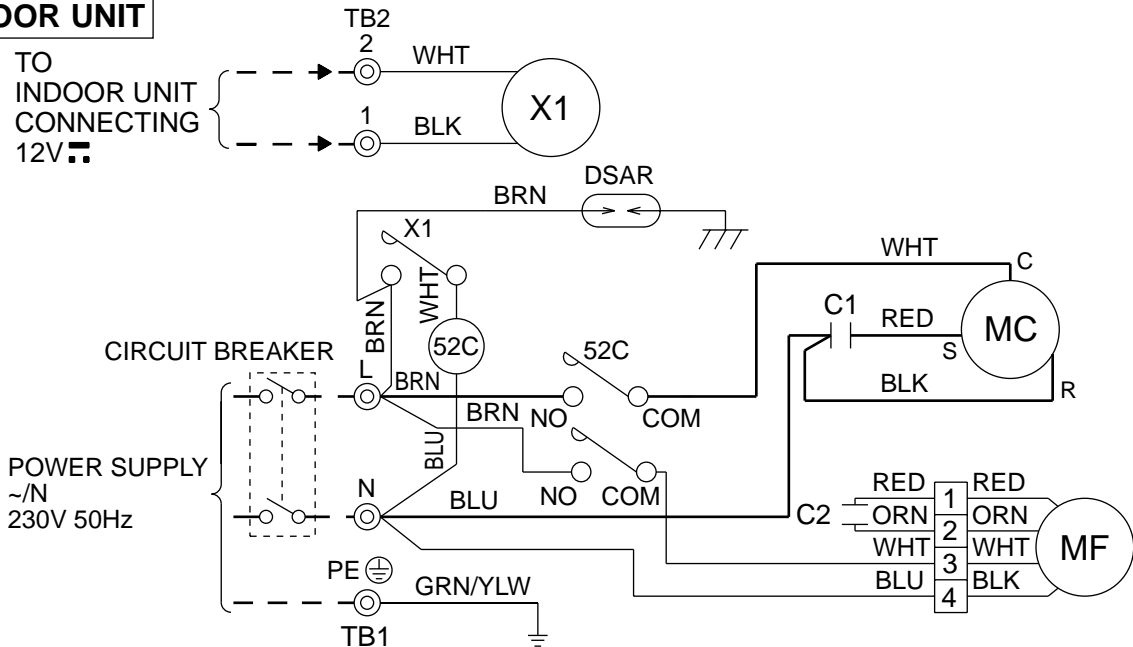

SYMBOL	NAME	SYMBOL	NAME	SYMBOL	NAME
C1	COMPRESSOR CAPACITOR	MC	COMPRESSOR (INNER PROTECTOR)	X1	RELAY
C2	OUTDOOR FAN CAPACITOR	MF	OUTDOOR FAN MOTOR (INNER PROTECTOR)	52C	COMPRESSOR CONTACTOR
DSAR	SURGE ABSORBER	TB1,TB2	TERMINAL BLOCK		

NOTES: 1.About the indoor side electric wiring refer to the indoor unit electric wiring diagram for servicing.
 2.Use copper conductors only. (For field wiring)
 3.Symbols below indicate.

⊙ : Terminal block □□□□ : Connector

MU-A30WV -[E1]

OUTDOOR UNIT

MODEL WIRING DIAGRAM

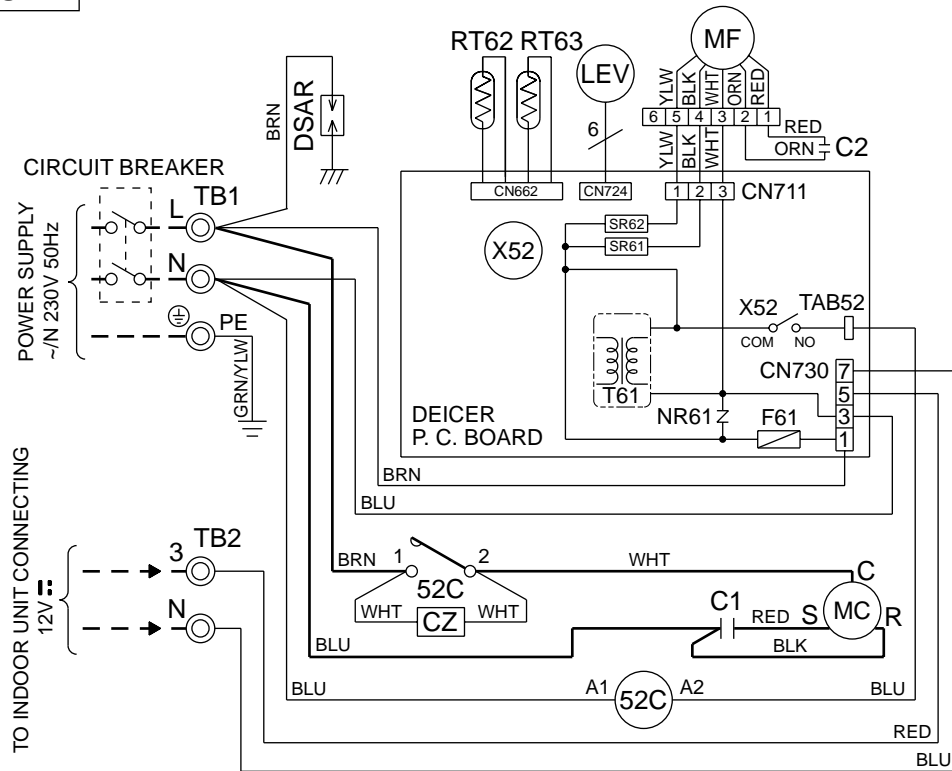

SYMBOL	NAME	SYMBOL	NAME	SYMBOL	NAME
CZ	CZ SURGE ABSRBER	MC	COMPRESSOR (INNER PROTECTOR)	SR62	SOLID STATE RELAY
C1	COMPRESSOR CAPACITOR	MF	OUTDOOR FAN MOTOR (INNER PROTECTOR)	TB1	TERMINAL BLOCK
C2	OUTDOOR FAN CAPACITOR	NR61	VARISTOR	TB2	TERMINAL BLOCK
DSAR	SURGE ABSORBER	RT62	DISCHARGE TEMPERATURE THERMISTOR	T61	TRANSFORMER
F61	FUSE(3.15A)	RT63	AMBIENT TEMPERATURE THERMISTOR	X52	CONTACTOR
LEV	EXPANSION VALVE COIL	SR61	SOLID STATE RELAY	52C	COMPRESSOR CONTACTOR

- NOTE 1. Use copper conductors only (For field wiring).
 2. Since the indoor and outdoor unit connecting wires have polarity, connect them according to the numbers (3,N).
 3. Symbols below indicate.
 ◎: Terminal block, □□□□: Connector

MU-A18WV -E1

Unit:mm

OUTDOOR UNIT

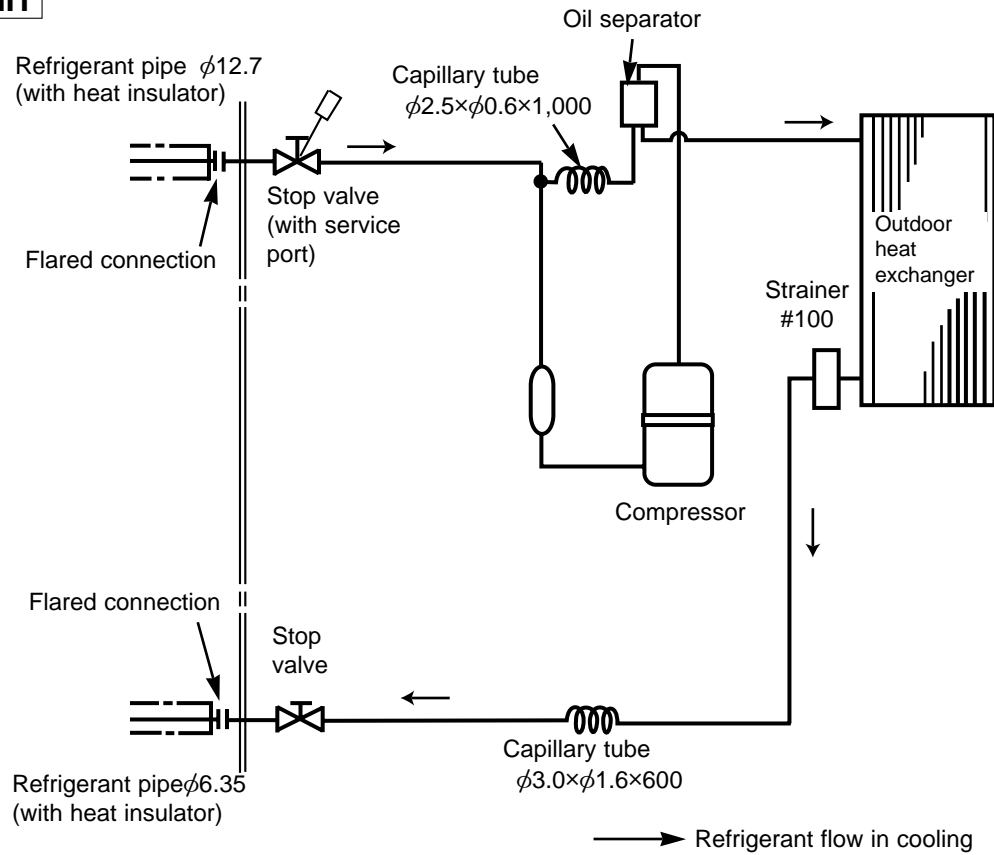

MU-A24WV -E1

OUTDOOR UNIT

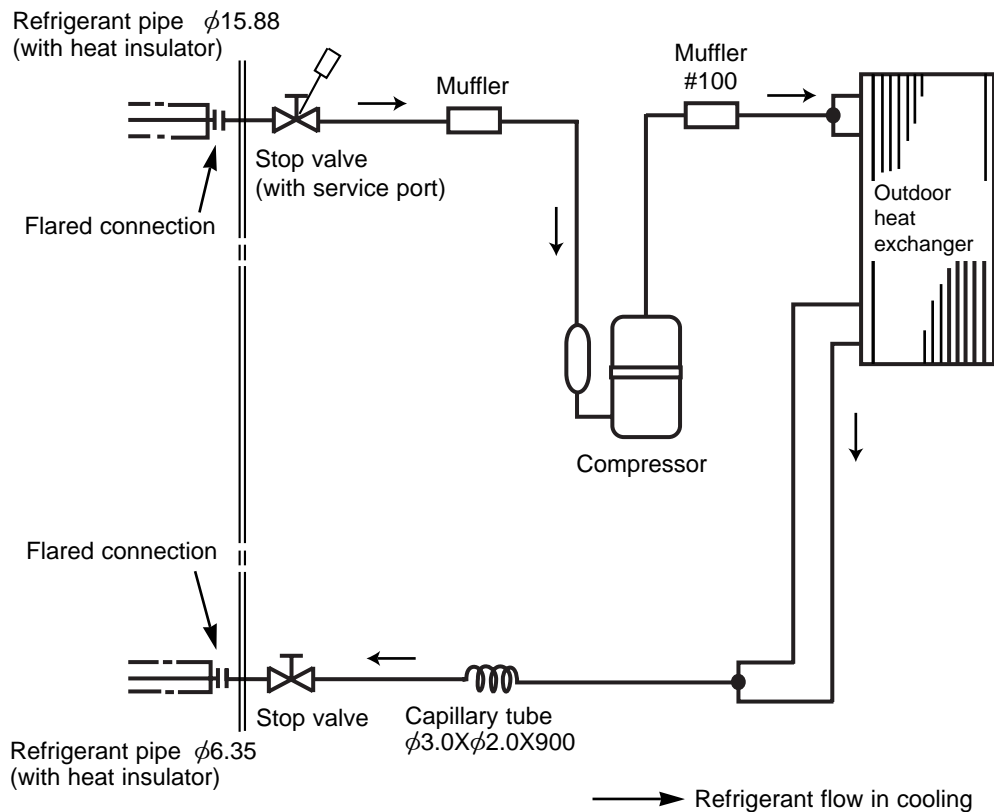

MU-A30WV - [E1]
OUTDOOR UNIT

Unit:mm

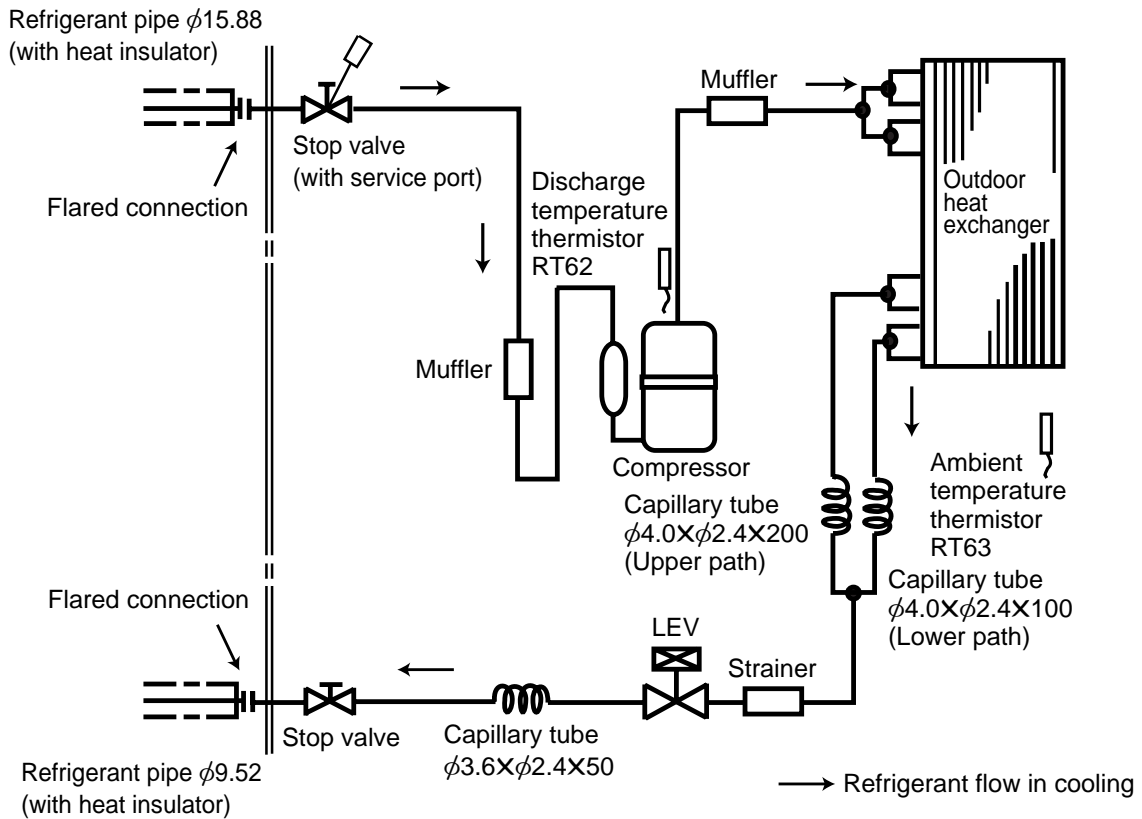

MAX. REFRIGERANT PIPING LENGTH

Model	Refrigerant piping Max. length : m A	Piping size O.D : mm		Length of connecting pipe : m	
		Gas	Liquid	Indoor unit	Outdoor unit
MU-A18WV - [E1]	25	12.7	6.35	Gas 0.43	Gas 0
MU-A24WV - [E1]				Liquid 0.5	Liquid 0
MU-A30WV - [E1]	30	15.88	9.52		

MAX. HEIGHT DIFFERENCE

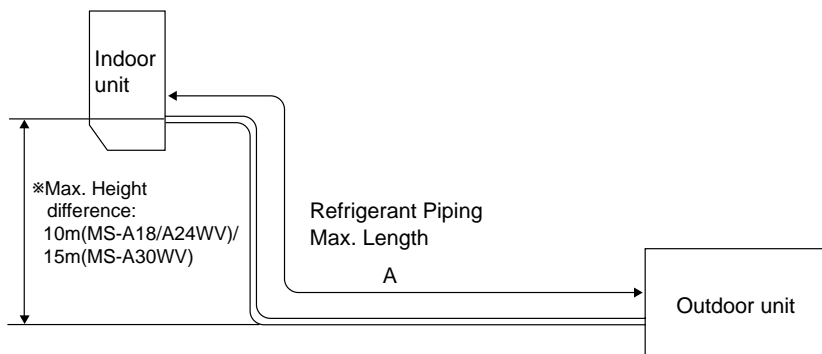

* Height difference should be within 10m(MS-A18/A24WV)/ 15m(MS-A30WV) regardless of which unit, indoor or outdoor position is high.

ADDITIONAL REFRIGERANT CHARGE(R410A : g)

Model	Outdoor unit precharged	Refrigerant piping length (one way)				
		7m	10m	15m	20m	25m
MU-A18WV - E1	1,400	0	60	160	260	360

Calculation : $Xg=20g/m \times (\text{Refrigerant piping length (m)}-7)$

Model	Outdoor unit precharged	Refrigerant piping length (one way)				
		7m	10m	15m	20m	25m
MU-A24WV - E1	1,900	0	60	160	260	360

Calculation : $Xg=20g/m \times (\text{Refrigerant piping length (m)}-7)$

Model	Outdoor unit precharged	Refrigerant piping length (one way)					
		7m	10m	15m	20m	25m	30m
MU-A30WV - E1	2,300	0	165	440	715	990	1,165

Calculation : $Xg=55g/m \times (\text{Refrigerant piping length(m)}-7)$

MU-A18WV -[E1] MU-A24WV -[E1] MU-A30WV -[E1]

The standard data contained in these specifications apply only to the operation of the air conditioner under normal conditions, since operating conditions vary according to the areas where these units are installed. The following information has been provided to clarify the operating characteristics of the air conditioner under the conditions indicated by the performance curve.

(1) GUARANTEED VOLTAGE

198 ~ 264V, 50Hz

(2) AIR FLOW

Air flow should be set at MAX.

(3) MAIN READINGS

- | | | |
|---|------|-----------|
| (1) Indoor intake air wet-bulb temperature : | °CWB | } Cooling |
| (2) Indoor outlet air wet-bulb temperature : | °CWB | |
| (3) Outdoor intake air dry-bulb temperature : | °CDB | |
| (4) Total input: | W | |

Indoor air wet/dry-bulb temperature difference on the left side of the chart on this page shows the difference between the indoor intake air wet/dry-bulb temperature and the indoor outlet air wet/dry-bulb temperature for your reference at service.

How to measure the indoor air wet-bulb/dry-bulb temperature difference

- Attach at least 2 sets of wet-and dry-bulb thermometers to the indoor air intake as shown in the figure, and at least 2 sets of wet-and dry-bulb thermometers to the indoor air outlet. The thermometers must be attached to the position where air speed is high.
- Attach at least 2 sets of wet-and dry-bulb thermometers to the outdoor air intake. Cover the thermometers to prevent direct rays of the sun.
- Check that the air filter is cleaned.
- Open windows and doors of room.
- Press the EMERGENCY OPERATION switch once to start the EMERGENCY COOL MODE.
- When system stabilizes after more than 15 minutes, measure temperature and take an average temperature.
- 10 minutes later, measure temperature again and check that the temperature does not change.

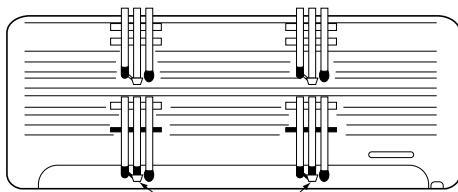
INDOOR UNIT

Wet-and dry-bulb thermometers
FRONT VIEW

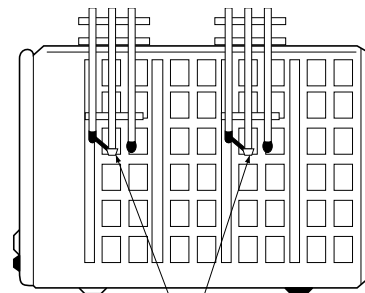
OUTDOOR UNIT

Wet-and dry-bulb thermometers
BACK VIEW

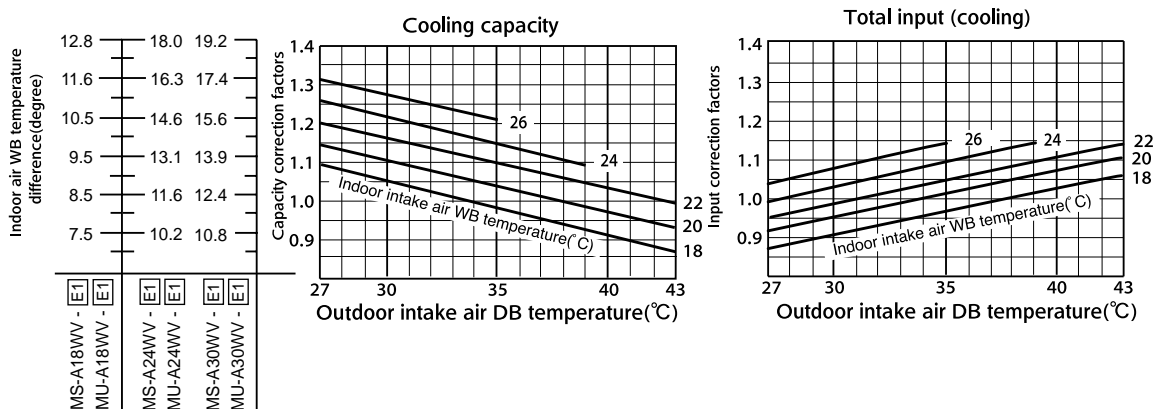
**OUTDOOR LOW PRESSURE AND OUTDOOR UNIT CURRENT COOL operation**

- ① Both indoor and outdoor unit are under the same temperature/humidity condition.

Dry-bulb temperature	Relative humidity(%)
20	50
25	60
30	70

② Air flow should be set at MAX.

③ The unit of pressure has been changed to MPa on the international system of units(SI unit system).
The conversion factor is : **1(MPa [Gauge]) =10.2(kgf/cm² [Gauge])**

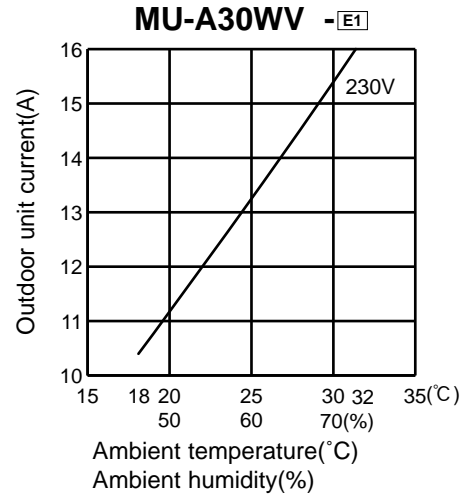
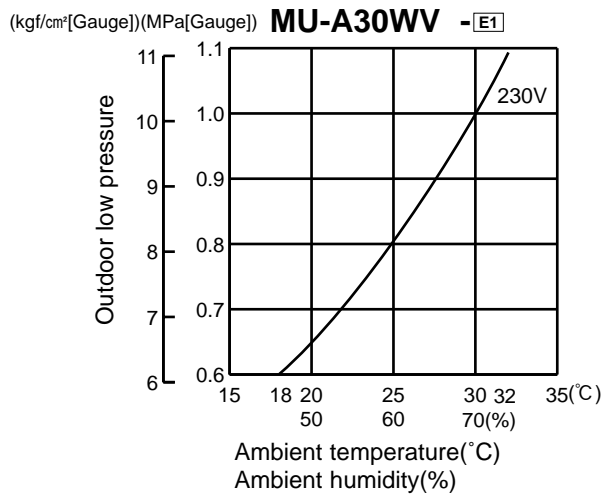
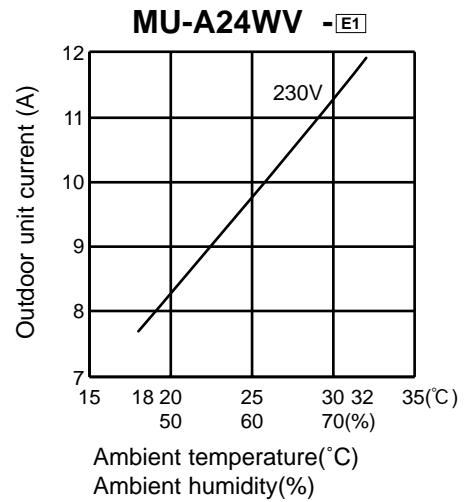
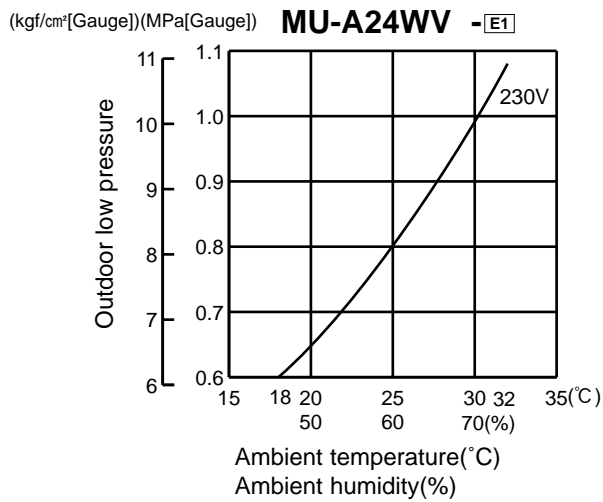
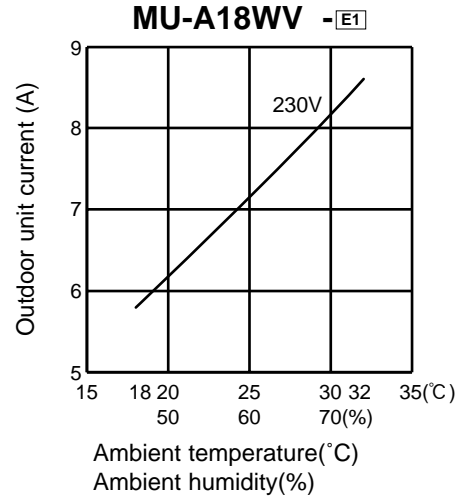
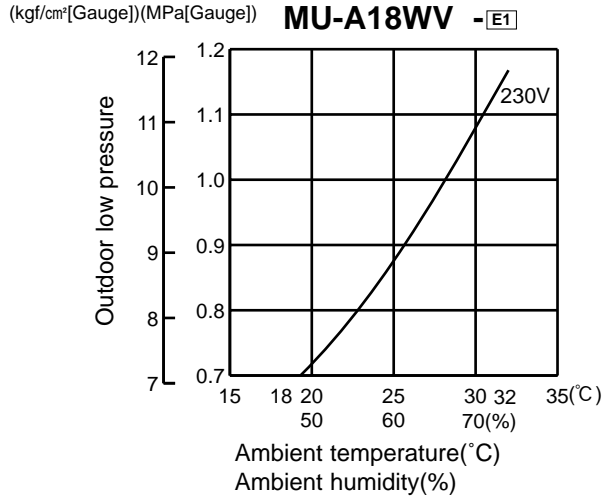

PERFORMANCE DATA COOL operation

MS-A18WV -E1 : MU-A18WV -E1 (230V)

CAPACITY : 5.0(KW) SHF : 0.65 INPUT : 1810(W)

INDOOR		OUTDOOR DB(°C)															
DB(°C)	WB(°C)	21				25				27				30			
		Q	SHC	SHF	INPUT	Q	SHC	SHF	INPUT	Q	SHC	SHF	INPUT	Q	SHC	SHF	INPUT
21	18	5.88	2.76	0.47	1448	5.63	2.64	0.47	1520	5.40	2.54	0.47	1593	5.20	2.44	0.47	1665
21	20	6.13	2.14	0.35	1520	5.88	2.06	0.35	1611	5.70	2.00	0.35	1647	5.50	1.93	0.35	1720
22	18	5.88	3.00	0.51	1448	5.63	2.87	0.51	1520	5.40	2.75	0.51	1593	5.20	2.65	0.51	1665
22	20	6.13	2.39	0.39	1520	5.88	2.29	0.39	1611	5.70	2.22	0.39	1647	5.50	2.15	0.39	1720
22	22	6.38	1.72	0.27	1575	6.15	1.66	0.27	1674	6.00	1.62	0.27	1720	5.75	1.55	0.27	1792
23	18	5.88	3.23	0.55	1448	5.63	3.09	0.55	1520	5.40	2.97	0.55	1593	5.20	2.86	0.55	1665
23	20	6.13	2.63	0.43	1520	5.88	2.53	0.43	1611	5.70	2.45	0.43	1647	5.50	2.37	0.43	1720
23	22	6.38	1.98	0.31	1575	6.15	1.91	0.31	1674	6.00	1.86	0.31	1720	5.75	1.78	0.31	1792
24	18	5.88	3.47	0.59	1448	5.63	3.32	0.59	1520	5.40	3.19	0.59	1593	5.20	3.07	0.59	1665
24	20	6.13	2.88	0.47	1520	5.88	2.76	0.47	1611	5.70	2.68	0.47	1647	5.50	2.59	0.47	1720
24	22	6.38	2.23	0.35	1575	6.15	2.15	0.35	1674	6.00	2.10	0.35	1720	5.75	2.01	0.35	1792
24	24	6.70	1.54	0.23	1647	6.45	1.48	0.23	1738	6.30	1.45	0.23	1792	6.10	1.40	0.23	1882
25	18	5.88	3.70	0.63	1448	5.63	3.54	0.63	1520	5.40	3.40	0.63	1593	5.20	3.28	0.63	1665
25	20	6.13	3.12	0.51	1520	5.88	3.00	0.51	1611	5.70	2.91	0.51	1647	5.50	2.81	0.51	1720
25	22	6.38	2.49	0.39	1575	6.15	2.40	0.39	1674	6.00	2.34	0.39	1720	5.75	2.24	0.39	1792
25	24	6.70	1.81	0.27	1647	6.45	1.74	0.27	1738	6.30	1.70	0.27	1792	6.10	1.65	0.27	1882
26	18	5.88	3.94	0.67	1448	5.63	3.77	0.67	1520	5.40	3.62	0.67	1593	5.20	3.48	0.67	1665
26	20	6.13	3.37	0.55	1520	5.88	3.23	0.55	1611	5.70	3.14	0.55	1647	5.50	3.03	0.55	1720
26	22	6.38	2.74	0.43	1575	6.15	2.64	0.43	1674	6.00	2.58	0.43	1720	5.75	2.47	0.43	1792
26	24	6.70	2.08	0.31	1647	6.45	2.00	0.31	1738	6.30	1.95	0.31	1792	6.10	1.89	0.31	1882
26	26	6.90	1.31	0.19	1738	6.70	1.27	0.19	1828	6.60	1.25	0.19	1882	6.40	1.22	0.19	1937
27	18	5.88	4.17	0.71	1448	5.63	3.99	0.71	1520	5.40	3.83	0.71	1593	5.20	3.69	0.71	1665
27	20	6.13	3.61	0.59	1520	5.88	3.47	0.59	1611	5.70	3.36	0.59	1647	5.50	3.25	0.59	1720
27	22	6.38	3.00	0.47	1575	6.15	2.89	0.47	1674	6.00	2.82	0.47	1720	5.75	2.70	0.47	1792
27	24	6.70	2.35	0.35	1647	6.45	2.26	0.35	1738	6.30	2.21	0.35	1792	6.10	2.14	0.35	1882
27	26	6.90	1.59	0.23	1738	6.70	1.54	0.23	1828	6.60	1.52	0.23	1882	6.40	1.47	0.23	1937
28	18	5.88	4.41	0.75	1448	5.63	4.22	0.75	1520	5.40	4.05	0.75	1593	5.20	3.90	0.75	1665
28	20	6.13	3.86	0.63	1520	5.88	3.70	0.63	1611	5.70	3.59	0.63	1647	5.50	3.47	0.63	1720
28	22	6.38	3.25	0.51	1575	6.15	3.14	0.51	1674	6.00	3.06	0.51	1720	5.75	2.93	0.51	1792
28	24	6.70	2.61	0.39	1647	6.45	2.52	0.39	1738	6.30	2.46	0.39	1792	6.10	2.38	0.39	1882
28	26	6.90	1.86	0.27	1738	6.70	1.81	0.27	1828	6.60	1.78	0.27	1882	6.40	1.73	0.27	1937
29	18	5.88	4.64	0.79	1448	5.63	4.44	0.79	1520	5.40	4.27	0.79	1593	5.20	4.11	0.79	1665
29	20	6.13	4.10	0.67	1520	5.88	3.94	0.67	1611	5.70	3.82	0.67	1647	5.50	3.69	0.67	1720
29	22	6.38	3.51	0.55	1575	6.15	3.38	0.55	1674	6.00	3.30	0.55	1720	5.75	3.16	0.55	1792
29	24	6.70	2.88	0.43	1647	6.45	2.77	0.43	1738	6.30	2.71	0.43	1792	6.10	2.62	0.43	1882
29	26	6.90	2.14	0.31	1738	6.70	2.08	0.31	1828	6.60	2.05	0.31	1882	6.40	1.98	0.31	1937
30	18	5.88	4.88	0.83	1448	5.63	4.67	0.83	1520	5.40	4.48	0.83	1593	5.20	4.32	0.83	1665
30	20	6.13	4.35	0.71	1520	5.88	4.17	0.71	1611	5.70	4.05	0.71	1647	5.50	3.91	0.71	1720
30	22	6.38	3.76	0.59	1575	6.15	3.63	0.59	1674	6.00	3.54	0.59	1720	5.75	3.39	0.59	1792
30	24	6.70	3.15	0.47	1647	6.45	3.03	0.47	1738	6.30	2.96	0.47	1792	6.10	2.87	0.47	1882
30	26	6.90	2.42	0.35	1738	6.70	2.35	0.35	1828	6.60	2.31	0.35	1882	6.40	2.24	0.35	1937
31	18	5.88	5.11	0.87	1448	5.63	4.89	0.87	1520	5.40	4.70	0.87	1593	5.20	4.52	0.87	1665
31	20	6.13	4.59	0.75	1520	5.88	4.41	0.75	1611	5.70	4.28	0.75	1647	5.50	4.13	0.75	1720
31	22	6.38	4.02	0.63	1575	6.15	3.87	0.63	1674	6.00	3.78	0.63	1720	5.75	3.62	0.63	1792
31	24	6.70	3.42	0.51	1647	6.45	3.29	0.51	1738	6.30	3.21	0.51	1792	6.10	3.11	0.51	1882
31	26	6.90	2.69	0.39	1738	6.70	2.61	0.39	1828	6.60	2.57	0.39	1882	6.40	2.50	0.39	1937
32	18	5.88	5.35	0.91	1448	5.63	5.12	0.91	1520	5.40	4.91	0.91	1593	5.20	4.73	0.91	1665
32	20	6.13	4.84	0.79	1520	5.88	4.64	0.79	1611	5.70	4.50	0.79	1647	5.50	4.35	0.79	1720
32	22	6.38	4.27	0.67	1575	6.15	4.12	0.67	1674	6.00	4.02	0.67	1720	5.75	3.85	0.67	1792
32	24	6.70	3.69	0.55	1647	6.45	3.55	0.55	1738	6.30	3.47	0.55	1792	6.10	3.36	0.55	1882
32	26	6.90	2.97	0.43	1738	6.70	2.88	0.43	1828	6.60	2.84	0.43	1882	6.40	2.75	0.43	1937

NOTE Q : Total capacity (kW) SHF : Sensible heat factor DB : Dry-bulb temperature
 SHC : Sensible heat capacity (kW) INPUT : Total power input (W) WB : Wet-bulb temperature

PERFORMANCE DATA COOL operation
MS-A18WV -[E1] : MU-A18WV -[E1] (230V)

CAPACITY : 5.0(KW) SHF : 0.65 INPUT : 1810(W)

INDOOR		OUTDOOR DB(°C)											
DB(°C)	WB(°C)	35				40				43			
		Q	SHC	SHF	INPUT	Q	SHC	SHF	INPUT	Q	SHC	SHF	INPUT
21	18	4.90	2.30	0.47	1774	4.50	2.12	0.47	1882	4.33	2.03	0.47	1919
21	20	5.15	1.80	0.35	1846	4.80	1.68	0.35	1937	4.63	1.62	0.35	1991
22	18	4.90	2.50	0.51	1774	4.50	2.30	0.51	1882	4.33	2.21	0.51	1919
22	20	5.15	2.01	0.39	1846	4.80	1.87	0.39	1937	4.63	1.80	0.39	1991
22	22	5.45	1.47	0.27	1919	5.10	1.38	0.27	2027	4.93	1.33	0.27	2063
23	18	4.90	2.70	0.55	1774	4.50	2.48	0.55	1882	4.33	2.38	0.55	1919
23	20	5.15	2.21	0.43	1846	4.80	2.06	0.43	1937	4.63	1.99	0.43	1991
23	22	5.45	1.69	0.31	1919	5.10	1.58	0.31	2027	4.93	1.53	0.31	2063
24	18	4.90	2.89	0.59	1774	4.50	2.66	0.59	1882	4.33	2.55	0.59	1919
24	20	5.15	2.42	0.47	1846	4.80	2.26	0.47	1937	4.63	2.17	0.47	1991
24	22	5.45	1.91	0.35	1919	5.10	1.79	0.35	2027	4.93	1.72	0.35	2063
24	24	5.75	1.32	0.23	1991	5.40	1.24	0.23	2082	5.25	1.21	0.23	2127
25	18	4.90	3.09	0.63	1774	4.50	2.84	0.63	1882	4.33	2.72	0.63	1919
25	20	5.15	2.63	0.51	1846	4.80	2.45	0.51	1937	4.63	2.36	0.51	1991
25	22	5.45	2.13	0.39	1919	5.10	1.99	0.39	2027	4.93	1.92	0.39	2063
25	24	5.75	1.55	0.27	1991	5.40	1.46	0.27	2082	5.25	1.42	0.27	2127
26	18	4.90	3.28	0.67	1774	4.50	3.02	0.67	1882	4.33	2.90	0.67	1919
26	20	5.15	2.83	0.55	1846	4.80	2.64	0.55	1937	4.63	2.54	0.55	1991
26	22	5.45	2.34	0.43	1919	5.10	2.19	0.43	2027	4.93	2.12	0.43	2063
26	24	5.75	1.78	0.31	1991	5.40	1.67	0.31	2082	5.25	1.63	0.31	2127
26	26	6.05	1.15	0.19	2063	5.70	1.08	0.19	2154	5.53	1.05	0.19	2199
27	18	4.90	3.48	0.71	1774	4.50	3.20	0.71	1882	4.33	3.07	0.71	1919
27	20	5.15	3.04	0.59	1846	4.80	2.83	0.59	1937	4.63	2.73	0.59	1991
27	22	5.45	2.56	0.47	1919	5.10	2.40	0.47	2027	4.93	2.31	0.47	2063
27	24	5.75	2.01	0.35	1991	5.40	1.89	0.35	2082	5.25	1.84	0.35	2127
27	26	6.05	1.39	0.23	2063	5.70	1.31	0.23	2154	5.53	1.27	0.23	2199
28	18	4.90	3.68	0.75	1774	4.50	3.38	0.75	1882	4.33	3.24	0.75	1919
28	20	5.15	3.24	0.63	1846	4.80	3.02	0.63	1937	4.63	2.91	0.63	1991
28	22	5.45	2.78	0.51	1919	5.10	2.60	0.51	2027	4.93	2.51	0.51	2063
28	24	5.75	2.24	0.39	1991	5.40	2.11	0.39	2082	5.25	2.05	0.39	2127
28	26	6.05	1.63	0.27	2063	5.70	1.54	0.27	2154	5.53	1.49	0.27	2199
29	18	4.90	3.87	0.79	1774	4.50	3.56	0.79	1882	4.33	3.42	0.79	1919
29	20	5.15	3.45	0.67	1846	4.80	3.22	0.67	1937	4.63	3.10	0.67	1991
29	22	5.45	3.00	0.55	1919	5.10	2.81	0.55	2027	4.93	2.71	0.55	2063
29	24	5.75	2.47	0.43	1991	5.40	2.32	0.43	2082	5.25	2.26	0.43	2127
29	26	6.05	1.88	0.31	2063	5.70	1.77	0.31	2154	5.53	1.71	0.31	2199
30	18	4.90	4.07	0.83	1774	4.50	3.74	0.83	1882	4.33	3.59	0.83	1919
30	20	5.15	3.66	0.71	1846	4.80	3.41	0.71	1937	4.63	3.28	0.71	1991
30	22	5.45	3.22	0.59	1919	5.10	3.01	0.59	2027	4.93	2.91	0.59	2063
30	24	5.75	2.70	0.47	1991	5.40	2.54	0.47	2082	5.25	2.47	0.47	2127
30	26	6.05	2.12	0.35	2063	5.70	2.00	0.35	2154	5.53	1.93	0.35	2199
31	18	4.90	4.26	0.87	1774	4.50	3.92	0.87	1882	4.33	3.76	0.87	1919
31	20	5.15	3.86	0.75	1846	4.80	3.60	0.75	1937	4.63	3.47	0.75	1991
31	22	5.45	3.43	0.63	1919	5.10	3.21	0.63	2027	4.93	3.10	0.63	2063
31	24	5.75	2.93	0.51	1991	5.40	2.75	0.51	2082	5.25	2.68	0.51	2127
31	26	6.05	2.36	0.39	2063	5.70	2.22	0.39	2154	5.53	2.15	0.39	2199
32	18	4.90	4.46	0.91	1774	4.50	4.10	0.91	1882	4.33	3.94	0.91	1919
32	20	5.15	4.07	0.79	1846	4.80	3.79	0.79	1937	4.63	3.65	0.79	1991
32	22	5.45	3.65	0.67	1919	5.10	3.42	0.67	2027	4.93	3.30	0.67	2063
32	24	5.75	3.16	0.55	1991	5.40	2.97	0.55	2082	5.25	2.89	0.55	2127
32	26	6.05	2.60	0.43	2063	5.70	2.45	0.43	2154	5.53	2.38	0.43	2199

NOTE Q : Total capacity (kW) SHF : Sensible heat factor DB : Dry-bulb temperature
 SHC : Sensible heat capacity (kW) INPUT : Total power input (W) WB : Wet-bulb temperature

PERFORMANCE DATA COOL operation
MS-A24WV -E1 : MU-A24WV -E1 (230V)

CAPACITY : 6.5(KW) SHF : 0.63 INPUT : 2480(W)

INDOOR		OUTDOOR DB(°C)															
DB(°C)	WB(°C)	21				25				27				30			
		Q	SHC	SHF	INPUT	Q	SHC	SHF	INPUT	Q	SHC	SHF	INPUT	Q	SHC	SHF	INPUT
21	18	7.64	3.44	0.45	1984	7.31	3.29	0.45	2083	7.02	3.16	0.45	2182	6.76	3.04	0.45	2282
21	20	7.96	2.63	0.33	2083	7.64	2.52	0.33	2207	7.41	2.45	0.33	2257	7.15	2.36	0.33	2356
22	18	7.64	3.74	0.49	1984	7.31	3.58	0.49	2083	7.02	3.44	0.49	2182	6.76	3.31	0.49	2282
22	20	7.96	2.95	0.37	2083	7.64	2.83	0.37	2207	7.41	2.74	0.37	2257	7.15	2.65	0.37	2356
22	22	8.29	2.07	0.25	2158	8.00	2.00	0.25	2294	7.80	1.95	0.25	2356	7.48	1.87	0.25	2455
23	18	7.64	4.05	0.53	1984	7.31	3.88	0.53	2083	7.02	3.72	0.53	2182	6.76	3.58	0.53	2282
23	20	7.96	3.26	0.41	2083	7.64	3.13	0.41	2207	7.41	3.04	0.41	2257	7.15	2.93	0.41	2356
23	22	8.29	2.40	0.29	2158	8.00	2.32	0.29	2294	7.80	2.26	0.29	2356	7.48	2.17	0.29	2455
24	18	7.64	4.35	0.57	1984	7.31	4.17	0.57	2083	7.02	4.00	0.57	2182	6.76	3.85	0.57	2282
24	20	7.96	3.58	0.45	2083	7.64	3.44	0.45	2207	7.41	3.33	0.45	2257	7.15	3.22	0.45	2356
24	22	8.29	2.73	0.33	2158	8.00	2.64	0.33	2294	7.80	2.57	0.33	2356	7.48	2.47	0.33	2455
24	24	8.71	1.83	0.21	2257	8.39	1.76	0.21	2381	8.19	1.72	0.21	2455	7.93	1.67	0.21	2579
25	18	7.64	4.66	0.61	1984	7.31	4.46	0.61	2083	7.02	4.28	0.61	2182	6.76	4.12	0.61	2282
25	20	7.96	3.90	0.49	2083	7.64	3.74	0.49	2207	7.41	3.63	0.49	2257	7.15	3.50	0.49	2356
25	22	8.29	3.07	0.37	2158	8.00	2.96	0.37	2294	7.80	2.89	0.37	2356	7.48	2.77	0.37	2455
25	24	8.71	2.18	0.25	2257	8.39	2.10	0.25	2381	8.19	2.05	0.25	2455	7.93	1.98	0.25	2579
26	18	7.64	4.96	0.65	1984	7.31	4.75	0.65	2083	7.02	4.56	0.65	2182	6.76	4.39	0.65	2282
26	20	7.96	4.22	0.53	2083	7.64	4.05	0.53	2207	7.41	3.93	0.53	2257	7.15	3.79	0.53	2356
26	22	8.29	3.40	0.41	2158	8.00	3.28	0.41	2294	7.80	3.20	0.41	2356	7.48	3.06	0.41	2455
26	24	8.71	2.53	0.29	2257	8.39	2.43	0.29	2381	8.19	2.38	0.29	2455	7.93	2.30	0.29	2579
26	26	8.97	1.52	0.17	2381	8.71	1.48	0.17	2505	8.58	1.46	0.17	2579	8.32	1.41	0.17	2654
27	18	7.64	5.27	0.69	1984	7.31	5.05	0.69	2083	7.02	4.84	0.69	2182	6.76	4.66	0.69	2282
27	20	7.96	4.54	0.57	2083	7.64	4.35	0.57	2207	7.41	4.22	0.57	2257	7.15	4.08	0.57	2356
27	22	8.29	3.73	0.45	2158	8.00	3.60	0.45	2294	7.80	3.51	0.45	2356	7.48	3.36	0.45	2455
27	24	8.71	2.87	0.33	2257	8.39	2.77	0.33	2381	8.19	2.70	0.33	2455	7.93	2.62	0.33	2579
27	26	8.97	1.88	0.21	2381	8.71	1.83	0.21	2505	8.58	1.80	0.21	2579	8.32	1.75	0.21	2654
28	18	7.64	5.58	0.73	1984	7.31	5.34	0.73	2083	7.02	5.12	0.73	2182	6.76	4.93	0.73	2282
28	20	7.96	4.86	0.61	2083	7.64	4.66	0.61	2207	7.41	4.52	0.61	2257	7.15	4.36	0.61	2356
28	22	8.29	4.06	0.49	2158	8.00	3.92	0.49	2294	7.80	3.82	0.49	2356	7.48	3.66	0.49	2455
28	24	8.71	3.22	0.37	2257	8.39	3.10	0.37	2381	8.19	3.03	0.37	2455	7.93	2.93	0.37	2579
28	26	8.97	2.24	0.25	2381	8.71	2.18	0.25	2505	8.58	2.15	0.25	2579	8.32	2.08	0.25	2654
29	18	7.64	5.88	0.77	1984	7.31	5.63	0.77	2083	7.02	5.41	0.77	2182	6.76	5.21	0.77	2282
29	20	7.96	5.18	0.65	2083	7.64	4.96	0.65	2207	7.41	4.82	0.65	2257	7.15	4.65	0.65	2356
29	22	8.29	4.39	0.53	2158	8.00	4.24	0.53	2294	7.80	4.13	0.53	2356	7.48	3.96	0.53	2455
29	24	8.71	3.57	0.41	2257	8.39	3.44	0.41	2381	8.19	3.36	0.41	2455	7.93	3.25	0.41	2579
29	26	8.97	2.60	0.29	2381	8.71	2.53	0.29	2505	8.58	2.49	0.29	2579	8.32	2.41	0.29	2654
30	18	7.64	6.19	0.81	1984	7.31	5.92	0.81	2083	7.02	5.69	0.81	2182	6.76	5.48	0.81	2282
30	20	7.96	5.49	0.69	2083	7.64	5.27	0.69	2207	7.41	5.11	0.69	2257	7.15	4.93	0.69	2356
30	22	8.29	4.72	0.57	2158	8.00	4.56	0.57	2294	7.80	4.45	0.57	2356	7.48	4.26	0.57	2455
30	24	8.71	3.92	0.45	2257	8.39	3.77	0.45	2381	8.19	3.69	0.45	2455	7.93	3.57	0.45	2579
30	26	8.97	2.96	0.33	2381	8.71	2.87	0.33	2505	8.58	2.83	0.33	2579	8.32	2.75	0.33	2654
31	18	7.64	6.49	0.85	1984	7.31	6.22	0.85	2083	7.02	5.97	0.85	2182	6.76	5.75	0.85	2282
31	20	7.96	5.81	0.73	2083	7.64	5.58	0.73	2207	7.41	5.41	0.73	2257	7.15	5.22	0.73	2356
31	22	8.29	5.06	0.61	2158	8.00	4.88	0.61	2294	7.80	4.76	0.61	2356	7.48	4.56	0.61	2455
31	24	8.71	4.27	0.49	2257	8.39	4.11	0.49	2381	8.19	4.01	0.49	2455	7.93	3.89	0.49	2579
31	26	8.97	3.32	0.37	2381	8.71	3.22	0.37	2505	8.58	3.17	0.37	2579	8.32	3.08	0.37	2654
32	18	7.64	6.80	0.89	1984	7.31	6.51	0.89	2083	7.02	6.25	0.89	2182	6.76	6.02	0.89	2282
32	20	7.96	6.13	0.77	2083	7.64	5.88	0.77	2207	7.41	5.71	0.77	2257	7.15	5.51	0.77	2356
32	22	8.29	5.39	0.65	2158	8.00	5.20	0.65	2294	7.80	5.07	0.65	2356	7.48	4.86	0.65	2455
32	24	8.71	4.62	0.53	2257	8.39	4.44	0.53	2381	8.19	4.34	0.53	2455	7.93	4.20	0.53	2579
32	26	8.97	3.68	0.41	2381	8.71	3.57	0.41	2505	8.58	3.52	0.41	2579	8.32	3.41	0.41	2654

NOTE Q : Total capacity (kW) SHF : Sensible heat factor DB : Dry-bulb temperature
SHC : Sensible heat capacity (kW) INPUT : Total power input (W) WB : Wet-bulb temperature

PERFORMANCE DATA COOL operation
MS-A24WV -[E1] : MU-A24WV -[E1] (230V)

CAPACITY : 6.5(KW) SHF : 0.63 INPUT : 2480(W)

INDOOR		OUTDOOR DB(°C)											
DB(°C)	WB(°C)	35				40				43			
		Q	SHC	SHF	INPUT	Q	SHC	SHF	INPUT	Q	SHC	SHF	INPUT
21	18	6.37	2.87	0.45	2430	5.85	2.63	0.45	2579	5.62	2.53	0.45	2629
21	20	6.70	2.21	0.33	2530	6.24	2.06	0.33	2654	6.01	1.98	0.33	2728
22	18	6.37	3.12	0.49	2430	5.85	2.87	0.49	2579	5.62	2.76	0.49	2629
22	20	6.70	2.48	0.37	2530	6.24	2.31	0.37	2654	6.01	2.22	0.37	2728
22	22	7.09	1.77	0.25	2629	6.63	1.66	0.25	2778	6.40	1.60	0.25	2827
23	18	6.37	3.38	0.53	2430	5.85	3.10	0.53	2579	5.62	2.98	0.53	2629
23	20	6.70	2.74	0.41	2530	6.24	2.56	0.41	2654	6.01	2.47	0.41	2728
23	22	7.09	2.05	0.29	2629	6.63	1.92	0.29	2778	6.40	1.86	0.29	2827
24	18	6.37	3.63	0.57	2430	5.85	3.33	0.57	2579	5.62	3.20	0.57	2629
24	20	6.70	3.01	0.45	2530	6.24	2.81	0.45	2654	6.01	2.71	0.45	2728
24	22	7.09	2.34	0.33	2629	6.63	2.19	0.33	2778	6.40	2.11	0.33	2827
24	24	7.48	1.57	0.21	2728	7.02	1.47	0.21	2852	6.83	1.43	0.21	2914
25	18	6.37	3.89	0.61	2430	5.85	3.57	0.61	2579	5.62	3.43	0.61	2629
25	20	6.70	3.28	0.49	2530	6.24	3.06	0.49	2654	6.01	2.95	0.49	2728
25	22	7.09	2.62	0.37	2629	6.63	2.45	0.37	2778	6.40	2.37	0.37	2827
25	24	7.48	1.87	0.25	2728	7.02	1.76	0.25	2852	6.83	1.71	0.25	2914
26	18	6.37	4.14	0.65	2430	5.85	3.80	0.65	2579	5.62	3.65	0.65	2629
26	20	6.70	3.55	0.53	2530	6.24	3.31	0.53	2654	6.01	3.19	0.53	2728
26	22	7.09	2.90	0.41	2629	6.63	2.72	0.41	2778	6.40	2.63	0.41	2827
26	24	7.48	2.17	0.29	2728	7.02	2.04	0.29	2852	6.83	1.98	0.29	2914
26	26	7.87	1.34	0.17	2827	7.41	1.26	0.17	2951	7.18	1.22	0.17	3013
27	18	6.37	4.40	0.69	2430	5.85	4.04	0.69	2579	5.62	3.88	0.69	2629
27	20	6.70	3.82	0.57	2530	6.24	3.56	0.57	2654	6.01	3.43	0.57	2728
27	22	7.09	3.19	0.45	2629	6.63	2.98	0.45	2778	6.40	2.88	0.45	2827
27	24	7.48	2.47	0.33	2728	7.02	2.32	0.33	2852	6.83	2.25	0.33	2914
27	26	7.87	1.65	0.21	2827	7.41	1.56	0.21	2951	7.18	1.51	0.21	3013
28	18	6.37	4.65	0.73	2430	5.85	4.27	0.73	2579	5.62	4.10	0.73	2629
28	20	6.70	4.08	0.61	2530	6.24	3.81	0.61	2654	6.01	3.67	0.61	2728
28	22	7.09	3.47	0.49	2629	6.63	3.25	0.49	2778	6.40	3.14	0.49	2827
28	24	7.48	2.77	0.37	2728	7.02	2.60	0.37	2852	6.83	2.53	0.37	2914
28	26	7.87	1.97	0.25	2827	7.41	1.85	0.25	2951	7.18	1.80	0.25	3013
29	18	6.37	4.90	0.77	2430	5.85	4.50	0.77	2579	5.62	4.33	0.77	2629
29	20	6.70	4.35	0.65	2530	6.24	4.06	0.65	2654	6.01	3.91	0.65	2728
29	22	7.09	3.76	0.53	2629	6.63	3.51	0.53	2778	6.40	3.39	0.53	2827
29	24	7.48	3.06	0.41	2728	7.02	2.88	0.41	2852	6.83	2.80	0.41	2914
29	26	7.87	2.28	0.29	2827	7.41	2.15	0.29	2951	7.18	2.08	0.29	3013
30	18	6.37	5.16	0.81	2430	5.85	4.74	0.81	2579	5.62	4.55	0.81	2629
30	20	6.70	4.62	0.69	2530	6.24	4.31	0.69	2654	6.01	4.15	0.69	2728
30	22	7.09	4.04	0.57	2629	6.63	3.78	0.57	2778	6.40	3.65	0.57	2827
30	24	7.48	3.36	0.45	2728	7.02	3.16	0.45	2852	6.83	3.07	0.45	2914
30	26	7.87	2.60	0.33	2827	7.41	2.45	0.33	2951	7.18	2.37	0.33	3013
31	18	6.37	5.41	0.85	2430	5.85	4.97	0.85	2579	5.62	4.78	0.85	2629
31	20	6.70	4.89	0.73	2530	6.24	4.56	0.73	2654	6.01	4.39	0.73	2728
31	22	7.09	4.32	0.61	2629	6.63	4.04	0.61	2778	6.40	3.91	0.61	2827
31	24	7.48	3.66	0.49	2728	7.02	3.44	0.49	2852	6.83	3.34	0.49	2914
31	26	7.87	2.91	0.37	2827	7.41	2.74	0.37	2951	7.18	2.66	0.37	3013
32	18	6.37	5.67	0.89	2430	5.85	5.21	0.89	2579	5.62	5.00	0.89	2629
32	20	6.70	5.16	0.77	2530	6.24	4.80	0.77	2654	6.01	4.63	0.77	2728
32	22	7.09	4.61	0.65	2629	6.63	4.31	0.65	2778	6.40	4.16	0.65	2827
32	24	7.48	3.96	0.53	2728	7.02	3.72	0.53	2852	6.83	3.62	0.53	2914
32	26	7.87	3.22	0.41	2827	7.41	3.04	0.41	2951	7.18	2.94	0.41	3013

NOTE Q : Total capacity (kW) SHF : Sensible heat factor DB : Dry-bulb temperature
SHC : Sensible heat capacity (kW) INPUT : Total power input (W) WB : Wet-bulb temperature

PERFORMANCE DATA COOL operation
MS-A30WV -E1 : MU-A30WV -E1 (230V)

CAPACITY : 8.5(KW) SHF : 0.62 INPUT : 3260(W)

INDOOR		OUTDOOR DB(°C)															
DB(°C)	WB(°C)	21				25				27				30			
		Q	SHC	SHF	INPUT	Q	SHC	SHF	INPUT	Q	SHC	SHF	INPUT	Q	SHC	SHF	INPUT
21	18	9.99	4.39	0.44	2608	9.56	4.21	0.44	2738	9.18	4.04	0.44	2869	8.84	3.89	0.44	2999
21	20	10.41	3.33	0.32	2738	9.99	3.20	0.32	2901	9.69	3.10	0.32	2967	9.35	2.99	0.32	3097
22	18	9.99	4.79	0.48	2608	9.56	4.59	0.48	2738	9.18	4.41	0.48	2869	8.84	4.24	0.48	2999
22	20	10.41	3.75	0.36	2738	9.99	3.60	0.36	2901	9.69	3.49	0.36	2967	9.35	3.37	0.36	3097
22	22	10.84	2.60	0.24	2836	10.46	2.51	0.24	3016	10.20	2.45	0.24	3097	9.78	2.35	0.24	3227
23	18	9.99	5.19	0.52	2608	9.56	4.97	0.52	2738	9.18	4.77	0.52	2869	8.84	4.60	0.52	2999
23	20	10.41	4.17	0.40	2738	9.99	4.00	0.40	2901	9.69	3.88	0.40	2967	9.35	3.74	0.40	3097
23	22	10.84	3.03	0.28	2836	10.46	2.93	0.28	3016	10.20	2.86	0.28	3097	9.78	2.74	0.28	3227
24	18	9.99	5.59	0.56	2608	9.56	5.36	0.56	2738	9.18	5.14	0.56	2869	8.84	4.95	0.56	2999
24	20	10.41	4.58	0.44	2738	9.99	4.39	0.44	2901	9.69	4.26	0.44	2967	9.35	4.11	0.44	3097
24	22	10.84	3.47	0.32	2836	10.46	3.35	0.32	3016	10.20	3.26	0.32	3097	9.78	3.13	0.32	3227
24	24	11.39	2.28	0.20	2967	10.97	2.19	0.20	3130	10.71	2.14	0.20	3227	10.37	2.07	0.20	3390
25	18	9.99	5.99	0.60	2608	9.56	5.74	0.60	2738	9.18	5.51	0.60	2869	8.84	5.30	0.60	2999
25	20	10.41	5.00	0.48	2738	9.99	4.79	0.48	2901	9.69	4.65	0.48	2967	9.35	4.49	0.48	3097
25	22	10.84	3.90	0.36	2836	10.46	3.76	0.36	3016	10.20	3.67	0.36	3097	9.78	3.52	0.36	3227
25	24	11.39	2.73	0.24	2967	10.97	2.63	0.24	3130	10.71	2.57	0.24	3227	10.37	2.49	0.24	3390
26	18	9.99	6.39	0.64	2608	9.56	6.12	0.64	2738	9.18	5.88	0.64	2869	8.84	5.66	0.64	2999
26	20	10.41	5.41	0.52	2738	9.99	5.19	0.52	2901	9.69	5.04	0.52	2967	9.35	4.86	0.52	3097
26	22	10.84	4.34	0.40	2836	10.46	4.18	0.40	3016	10.20	4.08	0.40	3097	9.78	3.91	0.40	3227
26	24	11.39	3.19	0.28	2967	10.97	3.07	0.28	3130	10.71	3.00	0.28	3227	10.37	2.90	0.28	3390
26	26	11.73	1.88	0.16	3130	11.39	1.82	0.16	3293	11.22	1.80	0.16	3390	10.88	1.74	0.16	3488
27	18	9.99	6.79	0.68	2608	9.56	6.50	0.68	2738	9.18	6.24	0.68	2869	8.84	6.01	0.68	2999
27	20	10.41	5.83	0.56	2738	9.99	5.59	0.56	2901	9.69	5.43	0.56	2967	9.35	5.24	0.56	3097
27	22	10.84	4.77	0.44	2836	10.46	4.60	0.44	3016	10.20	4.49	0.44	3097	9.78	4.30	0.44	3227
27	24	11.39	3.64	0.32	2967	10.97	3.51	0.32	3130	10.71	3.43	0.32	3227	10.37	3.32	0.32	3390
27	26	11.73	2.35	0.20	3130	11.39	2.28	0.20	3293	11.22	2.24	0.20	3390	10.88	2.18	0.20	3488
28	18	9.99	7.19	0.72	2608	9.56	6.89	0.72	2738	9.18	6.61	0.72	2869	8.84	6.36	0.72	2999
28	20	10.41	6.25	0.60	2738	9.99	5.99	0.60	2901	9.69	5.81	0.60	2967	9.35	5.61	0.60	3097
28	22	10.84	5.20	0.48	2836	10.46	5.02	0.48	3016	10.20	4.90	0.48	3097	9.78	4.69	0.48	3227
28	24	11.39	4.10	0.36	2967	10.97	3.95	0.36	3130	10.71	3.86	0.36	3227	10.37	3.73	0.36	3390
28	26	11.73	2.82	0.24	3130	11.39	2.73	0.24	3293	11.22	2.69	0.24	3390	10.88	2.61	0.24	3488
29	18	9.99	7.59	0.76	2608	9.56	7.27	0.76	2738	9.18	6.98	0.76	2869	8.84	6.72	0.76	2999
29	20	10.41	6.66	0.64	2738	9.99	6.39	0.64	2901	9.69	6.20	0.64	2967	9.35	5.98	0.64	3097
29	22	10.84	5.64	0.52	2836	10.46	5.44	0.52	3016	10.20	5.30	0.52	3097	9.78	5.08	0.52	3227
29	24	11.39	4.56	0.40	2967	10.97	4.39	0.40	3130	10.71	4.28	0.40	3227	10.37	4.15	0.40	3390
29	26	11.73	3.28	0.28	3130	11.39	3.19	0.28	3293	11.22	3.14	0.28	3390	10.88	3.05	0.28	3488
30	18	9.99	7.99	0.80	2608	9.56	7.65	0.80	2738	9.18	7.34	0.80	2869	8.84	7.07	0.80	2999
30	20	10.41	7.08	0.68	2738	9.99	6.79	0.68	2901	9.69	6.59	0.68	2967	9.35	6.36	0.68	3097
30	22	10.84	6.07	0.56	2836	10.46	5.85	0.56	3016	10.20	5.71	0.56	3097	9.78	5.47	0.56	3227
30	24	11.39	5.01	0.44	2967	10.97	4.82	0.44	3130	10.71	4.71	0.44	3227	10.37	4.56	0.44	3390
30	26	11.73	3.75	0.32	3130	11.39	3.64	0.32	3293	11.22	3.59	0.32	3390	10.88	3.48	0.32	3488
31	18	9.99	8.39	0.84	2608	9.56	8.03	0.84	2738	9.18	7.71	0.84	2869	8.84	7.43	0.84	2999
31	20	10.41	7.50	0.72	2738	9.99	7.19	0.72	2901	9.69	6.98	0.72	2967	9.35	6.73	0.72	3097
31	22	10.84	6.50	0.60	2836	10.46	6.27	0.60	3016	10.20	6.12	0.60	3097	9.78	5.87	0.60	3227
31	24	11.39	5.47	0.48	2967	10.97	5.26	0.48	3130	10.71	5.14	0.48	3227	10.37	4.98	0.48	3390
31	26	11.73	4.22	0.36	3130	11.39	4.10	0.36	3293	11.22	4.04	0.36	3390	10.88	3.92	0.36	3488
32	18	9.99	8.79	0.88	2608	9.56	8.42	0.88	2738	9.18	8.08	0.88	2869	8.84	7.78	0.88	2999
32	20	10.41	7.91	0.76	2738	9.99	7.59	0.76	2901	9.69	7.36	0.76	2967	9.35	7.11	0.76	3097
32	22	10.84	6.94	0.64	2836	10.46	6.69	0.64	3016	10.20	6.53	0.64	3097	9.78	6.26	0.64	3227
32	24	11.39	5.92	0.52	2967	10.97	5.70	0.52	3130	10.71	5.57	0.52	3227	10.37	5.39	0.52	3390
32	26	11.73	4.69	0.40	3130	11.39	4.56	0.40	3293	11.22	4.49	0.40	3390	10.88	4.35	0.40	3488

NOTE Q : Total capacity (kW) SHF : Sensible heat factor DB : Dry-bulb temperature
SHC : Sensible heat capacity (kW) INPUT : Total power input (W) WB : Wet-bulb temperature

PERFORMANCE DATA COOL operation
MS-A30WV -[E1] : MU-A30WV -[E1] (230V)

CAPACITY : 8.5(KW) SHF : 0.62 INPUT : 3260(W)

		OUTDOOR DB(°C)											
INDOOR DB(°C)	INDOOR WB(°C)	35				40				43			
		Q	SHC	SHF	INPUT	Q	SHC	SHF	INPUT	Q	SHC	SHF	INPUT
21	18	8.33	3.67	0.44	3195	7.65	3.37	0.44	3390	7.35	3.24	0.44	3456
21	20	8.76	2.80	0.32	3325	8.16	2.61	0.32	3488	7.86	2.52	0.32	3586
22	18	8.33	4.00	0.48	3195	7.65	3.67	0.48	3390	7.35	3.53	0.48	3456
22	20	8.76	3.15	0.36	3325	8.16	2.94	0.36	3488	7.86	2.83	0.36	3586
22	22	9.27	2.22	0.24	3456	8.67	2.08	0.24	3651	8.37	2.01	0.24	3716
23	18	8.33	4.33	0.52	3195	7.65	3.98	0.52	3390	7.35	3.82	0.52	3456
23	20	8.76	3.50	0.40	3325	8.16	3.26	0.40	3488	7.86	3.15	0.40	3586
23	22	9.27	2.59	0.28	3456	8.67	2.43	0.28	3651	8.37	2.34	0.28	3716
24	18	8.33	4.66	0.56	3195	7.65	4.28	0.56	3390	7.35	4.12	0.56	3456
24	20	8.76	3.85	0.44	3325	8.16	3.59	0.44	3488	7.86	3.46	0.44	3586
24	22	9.27	2.96	0.32	3456	8.67	2.77	0.32	3651	8.37	2.68	0.32	3716
24	24	9.78	1.96	0.20	3586	9.18	1.84	0.20	3749	8.93	1.79	0.20	3831
25	18	8.33	5.00	0.60	3195	7.65	4.59	0.60	3390	7.35	4.41	0.60	3456
25	20	8.76	4.20	0.48	3325	8.16	3.92	0.48	3488	7.86	3.77	0.48	3586
25	22	9.27	3.34	0.36	3456	8.67	3.12	0.36	3651	8.37	3.01	0.36	3716
25	24	9.78	2.35	0.24	3586	9.18	2.20	0.24	3749	8.93	2.14	0.24	3831
26	18	8.33	5.33	0.64	3195	7.65	4.90	0.64	3390	7.35	4.71	0.64	3456
26	20	8.76	4.55	0.52	3325	8.16	4.24	0.52	3488	7.86	4.09	0.52	3586
26	22	9.27	3.71	0.40	3456	8.67	3.47	0.40	3651	8.37	3.35	0.40	3716
26	24	9.78	2.74	0.28	3586	9.18	2.57	0.28	3749	8.93	2.50	0.28	3831
26	26	10.29	1.65	0.16	3716	9.69	1.55	0.16	3879	9.39	1.50	0.16	3961
27	18	8.33	5.66	0.68	3195	7.65	5.20	0.68	3390	7.35	5.00	0.68	3456
27	20	8.76	4.90	0.56	3325	8.16	4.57	0.56	3488	7.86	4.40	0.56	3586
27	22	9.27	4.08	0.44	3456	8.67	3.81	0.44	3651	8.37	3.68	0.44	3716
27	24	9.78	3.13	0.32	3586	9.18	2.94	0.32	3749	8.93	2.86	0.32	3831
27	26	10.29	2.06	0.20	3716	9.69	1.94	0.20	3879	9.39	1.88	0.20	3961
28	18	8.33	6.00	0.72	3195	7.65	5.51	0.72	3390	7.35	5.29	0.72	3456
28	20	8.76	5.25	0.60	3325	8.16	4.90	0.60	3488	7.86	4.72	0.60	3586
28	22	9.27	4.45	0.48	3456	8.67	4.16	0.48	3651	8.37	4.02	0.48	3716
28	24	9.78	3.52	0.36	3586	9.18	3.30	0.36	3749	8.93	3.21	0.36	3831
28	26	10.29	2.47	0.24	3716	9.69	2.33	0.24	3879	9.39	2.25	0.24	3961
29	18	8.33	6.33	0.76	3195	7.65	5.81	0.76	3390	7.35	5.59	0.76	3456
29	20	8.76	5.60	0.64	3325	8.16	5.22	0.64	3488	7.86	5.03	0.64	3586
29	22	9.27	4.82	0.52	3456	8.67	4.51	0.52	3651	8.37	4.35	0.52	3716
29	24	9.78	3.91	0.40	3586	9.18	3.67	0.40	3749	8.93	3.57	0.40	3831
29	26	10.29	2.88	0.28	3716	9.69	2.71	0.28	3879	9.39	2.63	0.28	3961
30	18	8.33	6.66	0.80	3195	7.65	6.12	0.80	3390	7.35	5.88	0.80	3456
30	20	8.76	5.95	0.68	3325	8.16	5.55	0.68	3488	7.86	5.35	0.68	3586
30	22	9.27	5.19	0.56	3456	8.67	4.86	0.56	3651	8.37	4.69	0.56	3716
30	24	9.78	4.30	0.44	3586	9.18	4.04	0.44	3749	8.93	3.93	0.44	3831
30	26	10.29	3.29	0.32	3716	9.69	3.10	0.32	3879	9.39	3.01	0.32	3961
31	18	8.33	7.00	0.84	3195	7.65	6.43	0.84	3390	7.35	6.18	0.84	3456
31	20	8.76	6.30	0.72	3325	8.16	5.88	0.72	3488	7.86	5.66	0.72	3586
31	22	9.27	5.56	0.60	3456	8.67	5.20	0.60	3651	8.37	5.02	0.60	3716
31	24	9.78	4.69	0.48	3586	9.18	4.41	0.48	3749	8.93	4.28	0.48	3831
31	26	10.29	3.70	0.36	3716	9.69	3.49	0.36	3879	9.39	3.38	0.36	3961
32	18	8.33	7.33	0.88	3195	7.65	6.73	0.88	3390	7.35	6.47	0.88	3456
32	20	8.76	6.65	0.76	3325	8.16	6.20	0.76	3488	7.86	5.98	0.76	3586
32	22	9.27	5.93	0.64	3456	8.67	5.55	0.64	3651	8.37	5.36	0.64	3716
32	24	9.78	5.08	0.52	3586	9.18	4.77	0.52	3749	8.93	4.64	0.52	3831
32	26	10.29	4.11	0.40	3716	9.69	3.88	0.40	3879	9.39	3.76	0.40	3961

NOTE Q : Total capacity (kW) SHF : Sensible heat factor DB : Dry-bulb temperature
SHC : Sensible heat capacity (kW) INPUT : Total power input (W) WB : Wet-bulb temperature

MU-A30WV -[E1]**9-1. "I FEEL CONTROL" () OPERATION****9-1-1. COOL mode of "I FEEL CONTROL"****1. Outdoor fan speed control <MU-A30WV>**

Outdoor fan speed is controlled according to the temperature of ambient temperature thermistor RT63.

Outdoor fan Low operation : When the outside temperature decreases to 20°C or less.

Until the outside temperature goes to 22°C.

Outdoor fan High operation : Until the outside temperature decreases to 20°C or less.

When the outside temperature goes to 22°C.

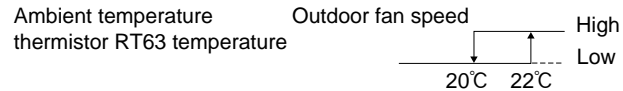

NOTE : When indoor fan speed is Low except FAN operation mode and the outside temperature is 30°C or less, the outdoor fan operates at Low.

Outdoor fan Low operation is cancelled according to the following conditions(① or ②):

- ① When the operation is not changed and the outside temperature goes to 33°C or more.
- ② When the operation is changed. (Change to FAN operation mode / Change of the indoor fan speed)

2. Discharge temperature protection <MU-A30WV>

The compressor is controlled by the temperature of discharge temperature thermistor RT62 for excess rise protection of compressor discharge pressure.

- Compressor

When the temperature of discharge temperature thermistor RT62 goes to 120°C or more, the compressor is turned OFF.

After 3 minutes since the compressor has been turned OFF, if the temperature of discharge temperature thermistor RT62 becomes 100°C or less, the compressor is turned ON.

9-1-2. DRY mode of "I FEEL CONTROL"**1. Outdoor fan speed control <MU-A30WV>**

Outdoor fan speed control is as same as one of COOL mode of "I FEEL CONTROL".

9-2. LEV control <MU-A30WV>

LEV (Expansion valve) is controlled by "Thermostat ON" commands given from the unit.

Basic specification	Controlled range	Minimum : 54 pulse, Maximum : 500 pulse
	Drive speed	30 ~ 90 pulse / second
	Opening set	The setting is always in opening direction. (To close the LEV, it is closed to the pulse smaller than the one which is set finally. Then the LEV is opened to the final setting pulse.)
General operation	Stop of indoor unit	Opening in stop : 150 pulse → LEV opening is set to becomes 500 pulse after 3 minutes passed.
	Remote controller ON	LEV positioning (LEV is closed completely at once)
	Power ON (Breaker ON)	LEV is positioned. However, afterwards, LEV is not positioned at the first remote controller ON.
	Approximate for 2 minutes since compressor has started.	Opening is set by the initial opening. (Initial opening is set according to each operation modes and outer temperature conditions.)
	From approximate 2 minutes to approximate 13 minutes (for 11 minutes) since compressor has started.	Opening is set by standard opening. (Standard opening is set according to each operation modes and outer temperature conditions.)
	After 13 minutes passed since compressor has started.	LEV opening is corrected to be once every 2 minutes so that discharge temperature becomes the target discharge temperature. (When the discharge temperature is lower than target one : LEV is corrected in closed direction, when the discharge temperature is higher than target one : LEV is corrected in opening direction.)
	At thermostat OFF	Opening in stop : 150 pulse → LEV is set to the initial opening after about 3 minutes passed.
	At thermostat ON	Same as the starting of compressor operation
	At remote controller OFF	Opening in stop : 150 pulse → LEV is set so that the opening is opened completely at the speed of 4 pulse every 5 seconds in opening after about 3 minutes passed.

(1) LEV opening correction by discharge temperature

The LEV opening is corrected according to the temperature difference between target discharge temperature (Tb) and actual discharge temperature (Ta).

① The LEV correction is used properly for two kinds according to the LEV opening status at operation off.

Rank	Opening immediately before having stopped last time	
	100 pulse or less	100 pulse or more
Ta (°C)	Cooling	Cooling
more than Tb+10	5	20
Tb+5 to Tb+10	2	10
Tb+2 to Tb+5	1	2
Tb-2 to Tb+2	0	0
Tb-5 to Tb-2	-1	-2
Tb-10 to Tb-5	-2	-5
less than Tb-10	-5	-10

NOTE : Discharge temperature : Ta, Target discharge temperature : Tb

② When the temperature difference ΔRT between indoor coil thermistor (main) RT12 and indoor coil thermistor (sub) RT13 in the indoor unit is 2°C or more for a fixed time at cool or dry operation, the target discharge temperature is changed. After the temperature is changed, when temperature difference ΔRT is 3°C or more, the target temperature is changed again. The LEV opening is controlled based on the changed target discharge temperature and the temperature difference ΔRT .

Ta ($^{\circ}\text{C}$)	ΔRT		
	less than 2°C	2°C or more and less than 3°C	3°C or more
more than Tb+10	20	60	60
Tb+5 to Tb+10	10	20	20
Tb+2 to Tb+5	2	2	2
Tb-2 to Tb+2	0	0	0
Tb-5 to Tb-2	-2	-2	-2
Tb-10 to Tb-5	-5	-5	-5
less than Tb-10	-10	-10	-10

NOTE : Discharge temperature : Ta, Target discharge temperature : Tb

The target discharge temperature (Tb) is set according to the operation mode or the unit status as follows.

Operation mode	Tb ($^{\circ}\text{C}$)
COOL (Normal)	80
COOL (ΔRT is less than 2°C , or ΔRT is 2°C or more and less than 3°C .)	70
COOL (ΔRT is 3°C or more.)	65

NOTE : Target discharge temperature : Tb

NOTE : When the discharge temperature (Ta) is 50°C or less on the cool operation LEV opening is set in 54 pulse. When this state continues for 20 minutes, the compressor is stopped and restarts in 3 minutes. When the compressor is stopped, the indoor unit indicates the abnormality of refrigerant system and stops. (OPERATION INDICATOR lamp is 10-time flashing on and off.)

(2) LEV time chart

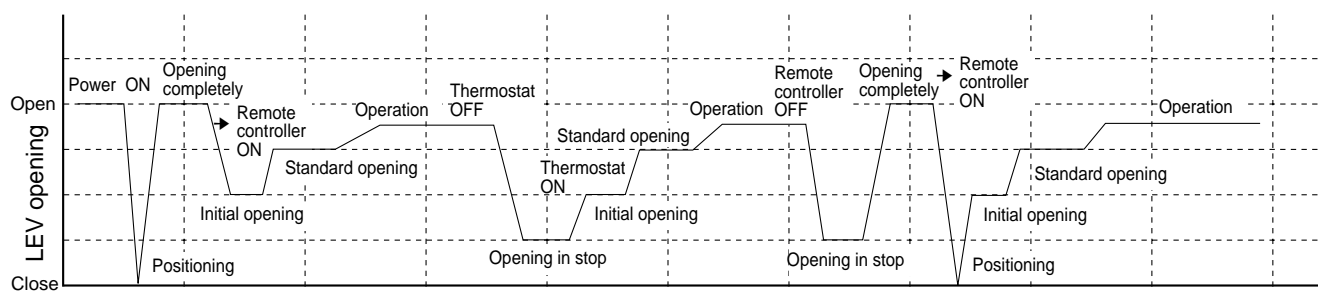

NOTE : Opening increases and decreases to be in the target discharge temperature during operation.

MU-A18WV -E1

MU-A24WV -E1

MU-A30WV -E1

10-1. Cautions on troubleshooting

1. Before troubleshooting, check the following:

- (1) Check the power supply voltage.
- (2) Check the indoor/outdoor connecting wire for mis-wiring.

2. Take care the following during servicing.

- (1) Before servicing the air conditioner, be sure to first turn off the remote controller to stop the main unit, and then after confirming the horizontal vane is closed, turn off the breaker and / or disconnect the power plug.
- (2) Be sure to turn OFF the power supply before removing the front panel, the cabinet, the top panel, and the electronic control P.C. board.
- (3) When removing the electronic control P.C. board, hold the edge of the board with care NOT to apply stress on the components.
- (4) When connecting or disconnecting the connectors, hold the housing of the connector. DO NOT pull the lead wires.

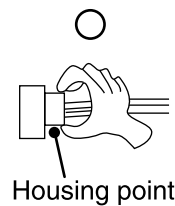
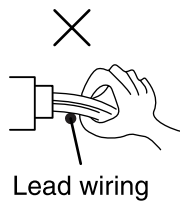

3. Troubleshooting procedure

- (1) First, check if the OPERATION INDICATOR lamp on the indoor unit is flashing on and off to indicate an abnormality. To make sure, check how many times the abnormality indication is flashing on and off before starting service work.
- (2) Before servicing that the connector and terminal are connected properly.
- (3) If the electronic control P.C. board is supposed to be defective, check the copper foil pattern for disconnection and the components for bursting and discoloration.
- (4) When troubleshooting, refer to the flow chart on page 26.

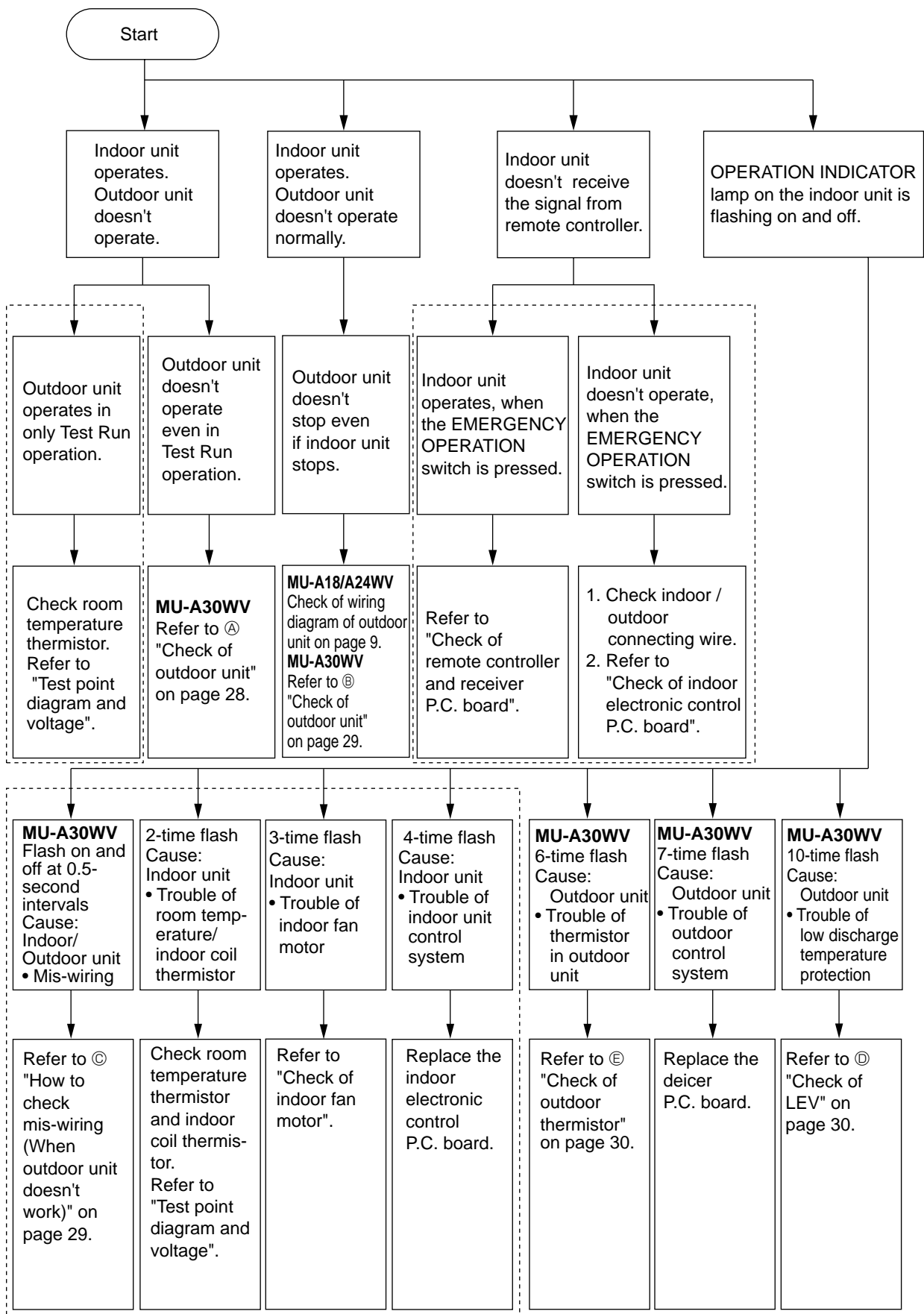

⋯ As for indoor unit, refer to service manual OB325.

10-2. Trouble criterion of main parts

MU-A18WV -^[E1] MU-A24WV -^[E1] MU-A30WV -^[E1]

Part name	Check method and criterion	Figure																									
Discharge temperature thermistor(RT62) MU-A30WV	Measure the resistance with a tester. Before measurement, hold the thermistor with your hands to warm it up. (Part temperature 0°C ~ 40°C) <table border="1"> <thead> <tr> <th>Normal</th> <th>Abnormal</th> </tr> </thead> <tbody> <tr> <td>120 kΩ ~ 800kΩ</td> <td>Open or short-circuit</td> </tr> </tbody> </table>	Normal	Abnormal	120 kΩ ~ 800kΩ	Open or short-circuit																						
Normal	Abnormal																										
120 kΩ ~ 800kΩ	Open or short-circuit																										
Ambient temperature thermistor(RT63) MU-A30WV	Measure the resistance with a tester. (Part temperature -10°C ~ 40°C) <table border="1"> <thead> <tr> <th>Normal</th> <th>Abnormal</th> </tr> </thead> <tbody> <tr> <td>5 kΩ ~ 60 kΩ</td> <td>Open or short-circuit</td> </tr> </tbody> </table>	Normal	Abnormal	5 kΩ ~ 60 kΩ	Open or short-circuit																						
Normal	Abnormal																										
5 kΩ ~ 60 kΩ	Open or short-circuit																										
Compressor (MC) INNER PROTECTOR 160± 5°C OPEN 90±10°C CLOSE	Measure the resistance between the terminals with a tester. (Part temperature -10°C ~ 40°C) <table border="1"> <thead> <tr> <th rowspan="2">Terminal</th> <th colspan="3">Normal</th> <th rowspan="2">Abnormal</th> </tr> <tr> <th>MU-A18WV</th> <th>MU-A24WV</th> <th>MU-A30WV</th> </tr> </thead> <tbody> <tr> <td>C - R</td> <td>1.59 Ω ~ 1.95 Ω</td> <td>0.71 Ω ~ 0.87 Ω</td> <td>0.56 Ω ~ 0.71 Ω</td> <td rowspan="2">Open or short-circuit</td> </tr> <tr> <td>C - S</td> <td>2.65 Ω ~ 3.24 Ω</td> <td>1.45 Ω ~ 1.77 Ω</td> <td>1.43 Ω ~ 1.76 Ω</td> </tr> </tbody> </table>	Terminal	Normal			Abnormal	MU-A18WV	MU-A24WV	MU-A30WV	C - R	1.59 Ω ~ 1.95 Ω	0.71 Ω ~ 0.87 Ω	0.56 Ω ~ 0.71 Ω	Open or short-circuit	C - S	2.65 Ω ~ 3.24 Ω	1.45 Ω ~ 1.77 Ω	1.43 Ω ~ 1.76 Ω									
Terminal	Normal			Abnormal																							
	MU-A18WV	MU-A24WV	MU-A30WV																								
C - R	1.59 Ω ~ 1.95 Ω	0.71 Ω ~ 0.87 Ω	0.56 Ω ~ 0.71 Ω	Open or short-circuit																							
C - S	2.65 Ω ~ 3.24 Ω	1.45 Ω ~ 1.77 Ω	1.43 Ω ~ 1.76 Ω																								
Outdoor fan motor(MF) INNER PROTECTOR MU-A18WV 135± 5°C OPEN (87±15°C CLOSE*) MU-A24WV 130± 5°C OPEN (83±15°C CLOSE*) MU-A30WV 135± 5°C OPEN (87±15°C CLOSE*)	Measure the resistance between the terminals with a tester. (Part temperature -10°C ~ 40°C) <table border="1"> <thead> <tr> <th rowspan="2">Color of lead wire</th> <th colspan="3">Normal</th> <th rowspan="2">Abnormal</th> </tr> <tr> <th>MU-A18WV</th> <th>MU-A24WV</th> <th>MU-A30WV</th> </tr> </thead> <tbody> <tr> <td>WHT - BLK</td> <td>103 Ω ~ 126 Ω</td> <td>63 Ω ~ 77 Ω</td> <td>55 Ω ~ 68 Ω</td> <td rowspan="4">Open or short-circuit</td> </tr> <tr> <td>BLK - RED</td> <td>89 Ω ~ 120 Ω</td> <td>79 Ω ~ 96 Ω</td> <td>-</td> </tr> <tr> <td>BLK - YLW</td> <td>-</td> <td>-</td> <td>49 Ω ~ 61 Ω</td> </tr> <tr> <td>YLW - RED</td> <td>-</td> <td>-</td> <td>22 Ω ~ 29 Ω</td> </tr> </tbody> </table>	Color of lead wire	Normal			Abnormal	MU-A18WV	MU-A24WV	MU-A30WV	WHT - BLK	103 Ω ~ 126 Ω	63 Ω ~ 77 Ω	55 Ω ~ 68 Ω	Open or short-circuit	BLK - RED	89 Ω ~ 120 Ω	79 Ω ~ 96 Ω	-	BLK - YLW	-	-	49 Ω ~ 61 Ω	YLW - RED	-	-	22 Ω ~ 29 Ω	<p>MU-A18/A24WV</p> <p>MU-A30WV</p>
Color of lead wire	Normal			Abnormal																							
	MU-A18WV	MU-A24WV	MU-A30WV																								
WHT - BLK	103 Ω ~ 126 Ω	63 Ω ~ 77 Ω	55 Ω ~ 68 Ω	Open or short-circuit																							
BLK - RED	89 Ω ~ 120 Ω	79 Ω ~ 96 Ω	-																								
BLK - YLW	-	-	49 Ω ~ 61 Ω																								
YLW - RED	-	-	22 Ω ~ 29 Ω																								
LEV(Expansion valve) MU-A30WV	Measure the resistance with a tester. (Part temperature : -10°C ~ 40°C) <table border="1"> <thead> <tr> <th>Color of lead wire</th> <th>Normal</th> <th>Abnormal</th> </tr> </thead> <tbody> <tr> <td>WHT - RED</td> <td rowspan="4">41.0 Ω ~ 49.0 Ω</td> <td rowspan="4">Open or short-circuit</td> </tr> <tr> <td>RED - ORN</td> </tr> <tr> <td>YLW - BRN</td> </tr> <tr> <td>BRN - BLU</td> </tr> </tbody> </table>	Color of lead wire	Normal	Abnormal	WHT - RED	41.0 Ω ~ 49.0 Ω	Open or short-circuit	RED - ORN	YLW - BRN	BRN - BLU																	
Color of lead wire	Normal	Abnormal																									
WHT - RED	41.0 Ω ~ 49.0 Ω	Open or short-circuit																									
RED - ORN																											
YLW - BRN																											
BRN - BLU																											

* Reference value

Ⓟ:INNER PROTECTOR

Compressor and/or outdoor fan motor doesn't operate.

A Check of outdoor unit MU-A30WV

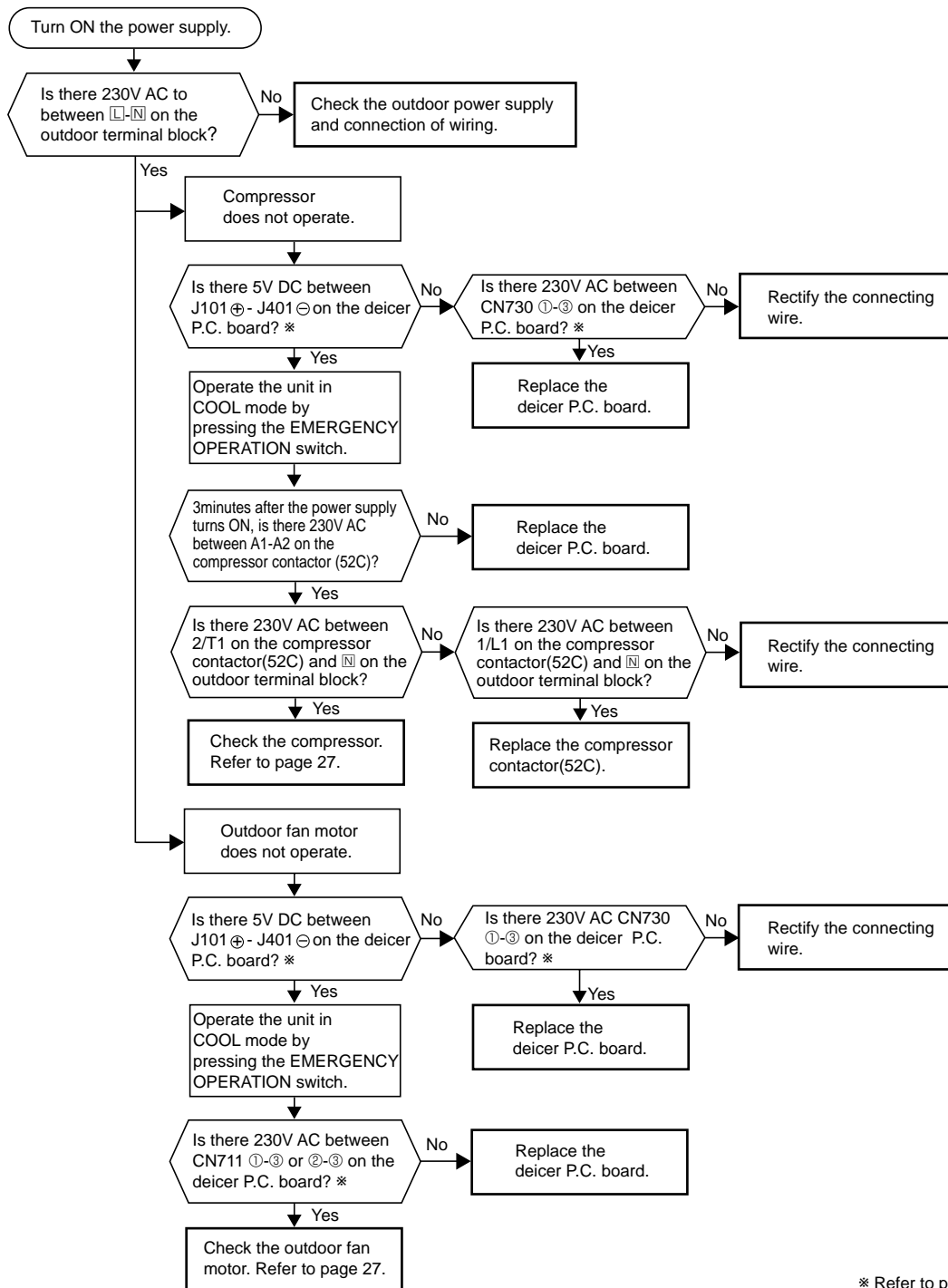

* Refer to page 31.

Compressor and/or outdoor fan motor doesn't stop.

B Check of outdoor unit MU-A30WV

- ① Turn OFF the power supply.
- ② After 30 seconds, turn ON the power supply again.
- ③ Operate the unit in COOL mode by pressing the EMERGENCY OPERATION switch.
- ④ Operate the unit for 1 minute or more and stop it by pressing the EMERGENCY OPERATION switch again.

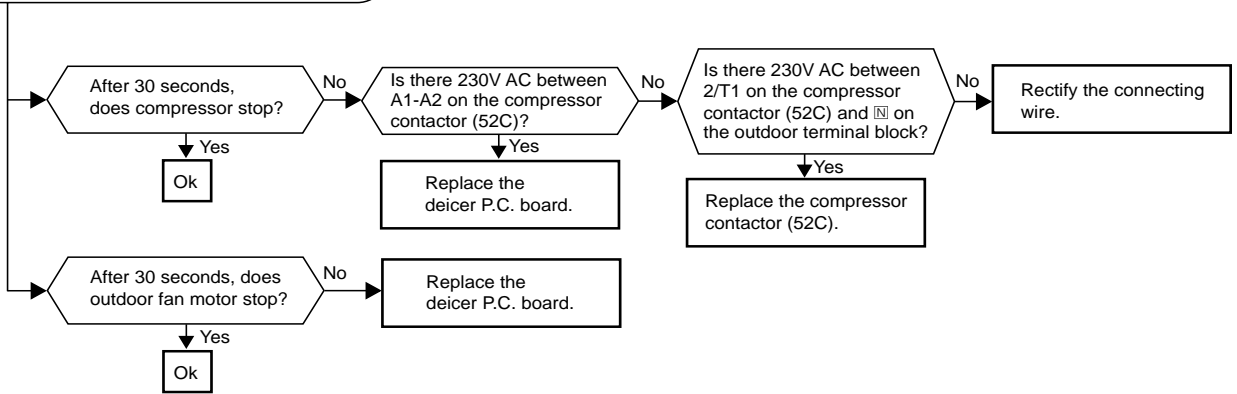

When OPERATION INDICATOR lamp flashes ON and OFF in every 0.5-second. Outdoor unit doesn't operate.

C How to check mis-wiring MU-A30WV

※ Short circuit of JPG and JPS on the indoor electronic control P.C. board enables self-check to be displayed in 3 seconds.

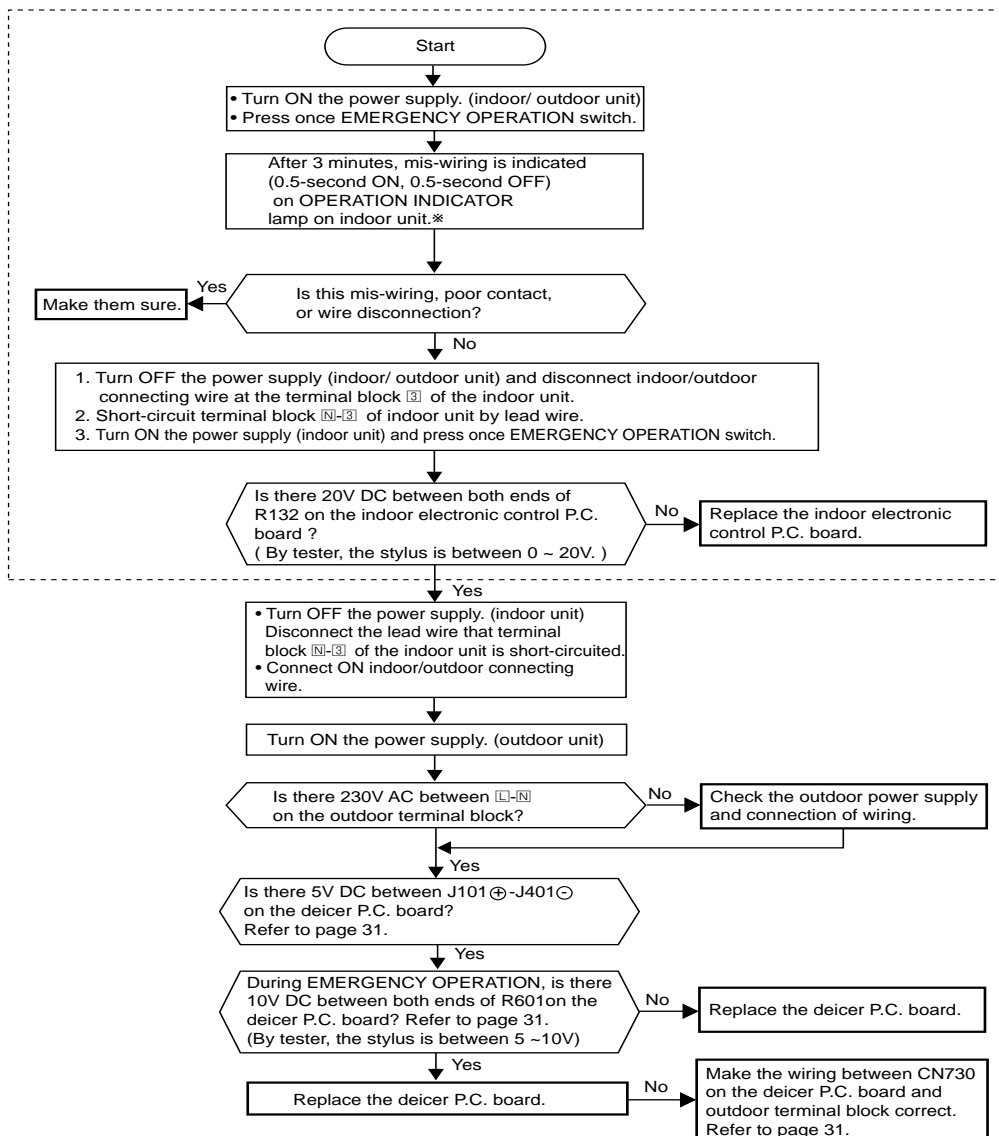

As for indoor unit, refer to service manual OB325.

When OPERATION INDICATOR lamp flashes 10-time.
Cooling doesn't operate.

D Check of LEV (Expansion valve)

MU-A30WV

- ① During pressing OPERATION SELECT button on remote controller, press RESET button.
- ② First, release RESET button.
(Confirm all displays of remote controller.)
- ③ Then release OPERATION SELECT button.

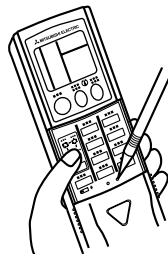

- ① During pressing OPERATION SELECT button on remote controller, press RESET button.
- ② First, release RESET button.

With remote controller set toward the indoor unit, press OPERATE/ STOP(ON/ OFF) button and confirm one beep tone.

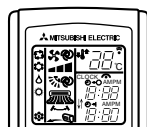

- (Confirm all displays of remote controller.)
- ③ Then release OPERATION SELECT button.

LEV operates in full-opening direction.

Do you hear LEV "click, click....." ?
Do you touch LEV and feel it vibrate?

Yes → Ok

No

Is LEV coil properly fixed to the body?

No

Properly fix LEV coil to the body.

Yes

Does the resistance of LEV coil have the characteristics?

Yes

Replace the deicer P.C. board.

No

Replace the LEV coil.

Characteristics of LEV coil

LEV (CN724)	Resistance
WHT-RED	41.0 Ω ~ 49.0 Ω
RED-ORN	
YLW-BRN	
BRN-BLU	

NOTE : After check of LEV, do the undermentioned operations.

1. Turn OFF the power supply of the unit and turn ON again.
2. Press the RESET button on the remote controller.

When OPERATION INDICATOR lamp flashes 6-time.
Thermistors in the outdoor unit are abnormal.

E Check of outdoor thermistor

MU-A30WV

* Disconnect the connectors CN662 from the deicer P.C. board.
(Check the characteristics of each thermistor.)

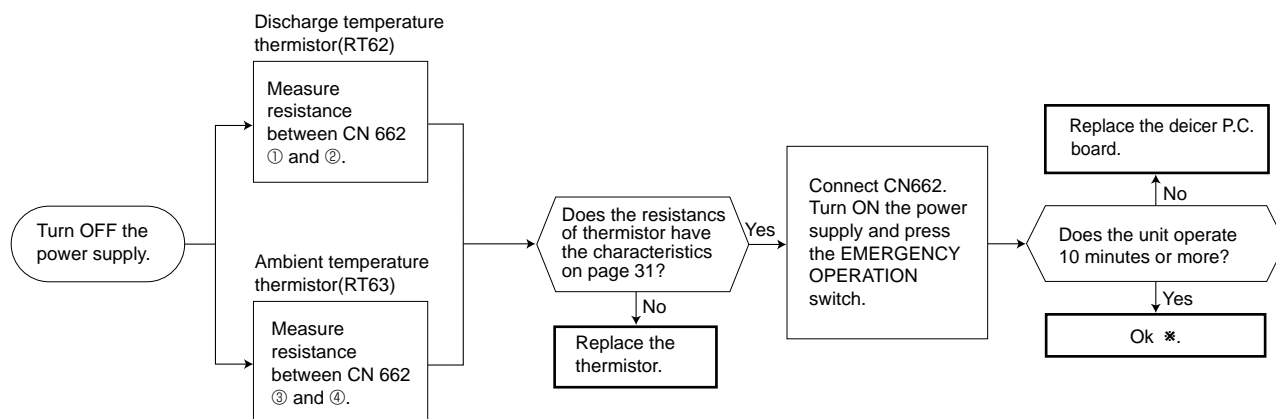

* It is thought defective contact of the connector.

MU-A30WV -E1
Outdoor deicer P.C. board

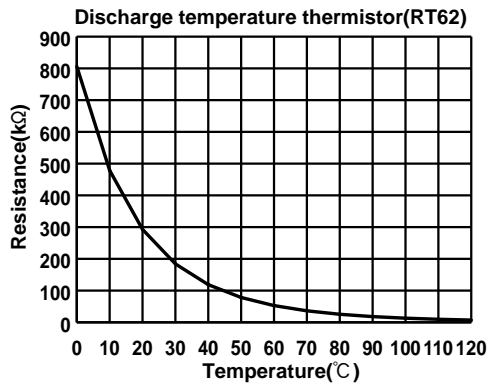

Ambient temperature thermistor (RT63)

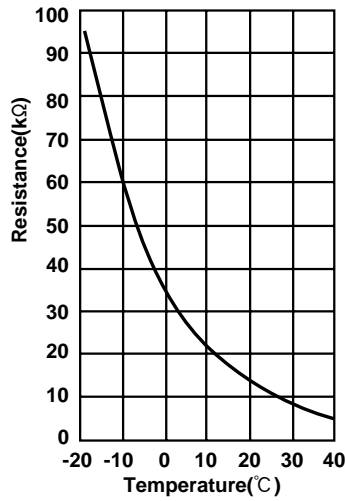

CN662 ①-②
 Discharge temperature thermistor (RT62)
 (Refer to page 30.)

CN662 ③-④
 Ambient temperature thermistor (RT63)
 (Refer to page 30.)

LEV connector (CN724)

Fan motor connector (CN711)

Varistor (NR62)

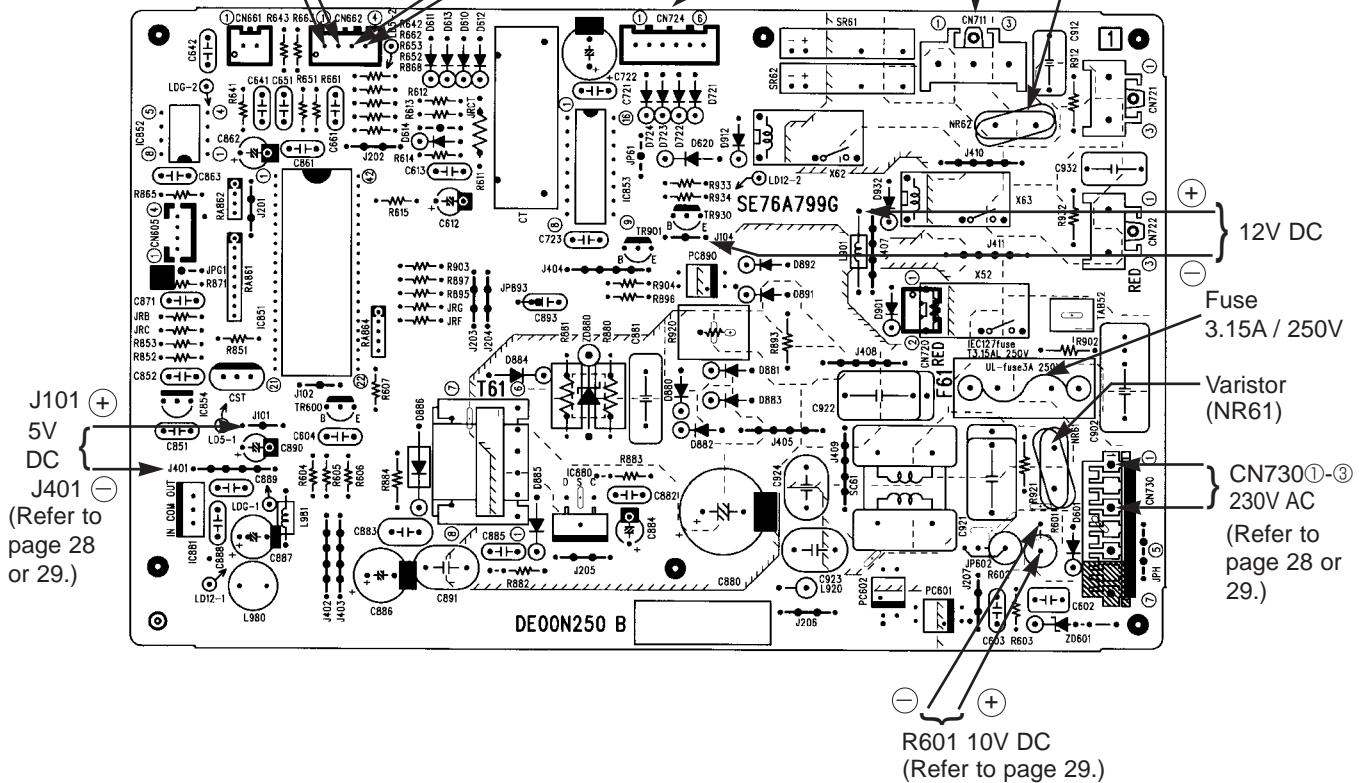

<"Terminal with lock mechanism" Detaching points>

In case of terminal with lock mechanism, detach the terminal as shown below.
 There are two types (Refer to (1) and (2)) of the terminal with lock mechanism.
 The terminal with no lock mechanism can be removed by pulling it out.
 Check the shape of the terminal and work.

(1) Slide the sleeve and check if there is a locking lever or not.

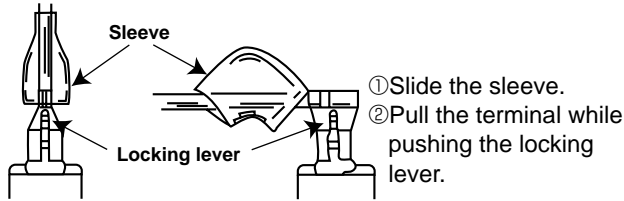

(2) The terminal with this connector is a terminal with lock mechanism

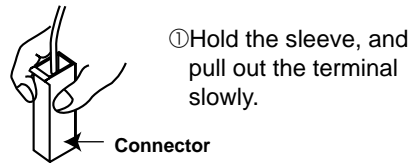

**11-1. MU-A18WV -E1
 OUTDOOR UNIT**

OPERATING PROCEDURE	PHOTOS
<p>1. Removing the cabinet</p> <p>(1) Remove the screws of the cabinet. (2) Hold the down of the cabinet on the both side and remove the cabinet.</p> <p>Photo 2</p> <p>Screws of the cabinet</p>	<p>Photo 1</p> <p>Service panel</p> <p>Screws of the cabinet</p>
<p>2. Removing the electrical parts</p> <p>(1) Remove the service panel and the cabinet. (2) Remove the following parts.</p> <ul style="list-style-type: none"> •Compressor capacitor (C1) •Outdoor fan capacitor (C2) •Terminal block (TB1, TB2) •Compressor contactor (52C) 	<p>Photo 3</p> <p>Outdoor fan capacitor(C2)</p> <p>Connector</p> <p>Compressor contactor(52C)</p> <p>Compressor capacitor(C1)</p> <p>Terminal blocks (TB1, TB2)</p>

OPERATING PROCEDURE

3. Removing the outdoor fan motor

- (1) Remove the cabinet. (Refer to 1.)
- (2) Disconnect the connector and remove the hooked lead wire from the fan motor.
- (3) Remove the propeller nut and remove the propeller.
- (4) Remove screws fixing the outdoor fan motor.
- (5) Remove the outdoor fan motor.

PHOTOS

Photo 4

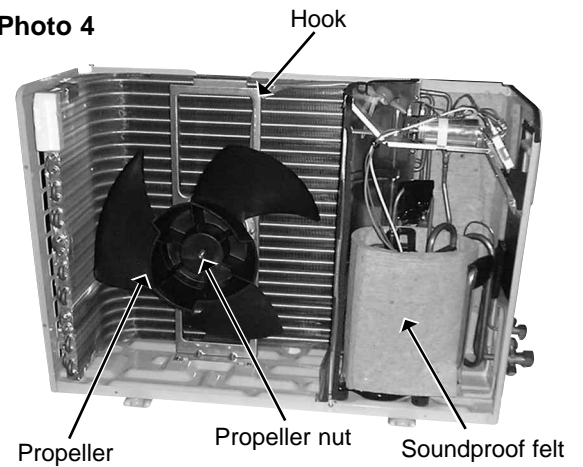

4. Removing the compressor

- (1) Remove the cabinet. (Refer to 1.)
- (2) Remove the relay panel.
- (3) Remove the soundproof felt.
- (4) Remove the terminal cover on the compressor.
- (5) Disconnect lead wires from the glass terminal of the compressor.
- (6) Recover gas from the refrigerant circuit.
- (7) Disconnect the welded part of the discharge pipe.
- (8) Disconnect the welded part of the suction pipe.
- (9) Remove nuts fixing the compressor.
- (10) Remove the compressor.

NOTE

- Before using a burner, reclaim gas from the pipes until the pressure gauge shows 0 kg/cm² (MPa).
- Use the burner under the condition that gas can be recovered even when the inner pressure rises by heat.

Photo 5

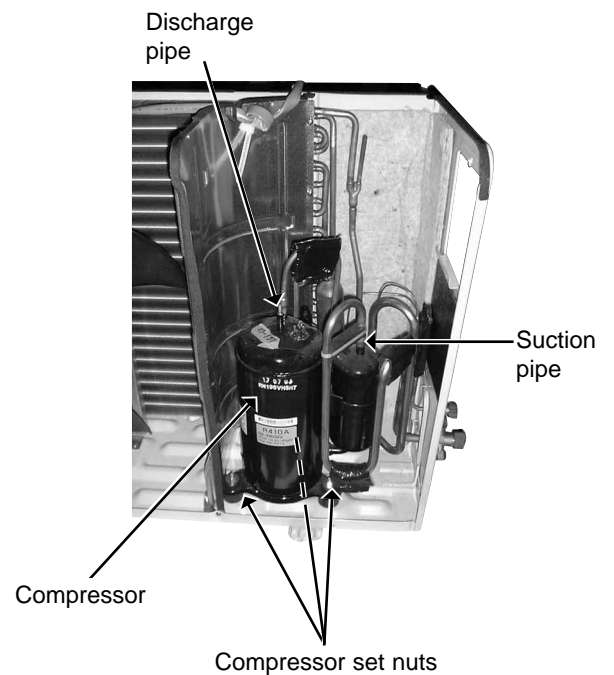

11-2. MU-A24WV -E1
OUTDOOR UNIT

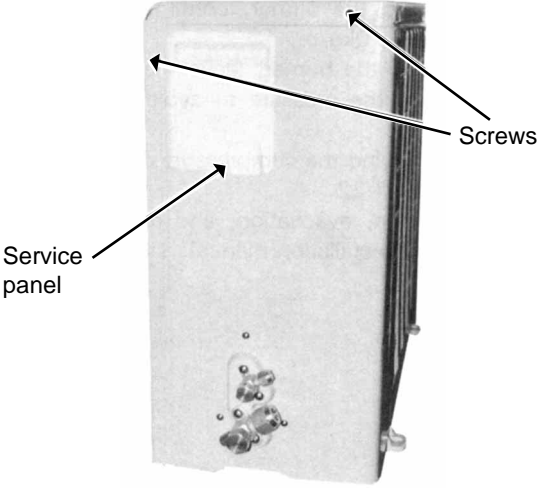
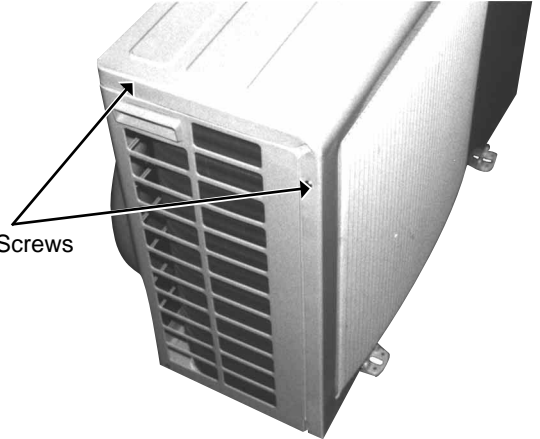
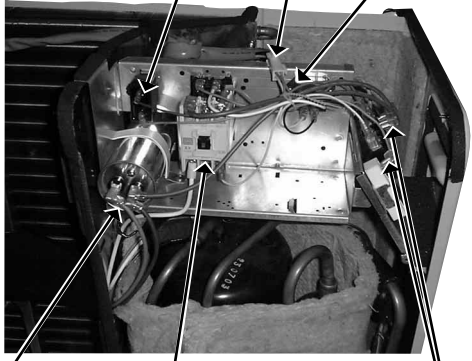
OPERATING PROCEDURE	PHOTOS
<p>1. Removing the cabinet</p> <p>(1) Remove the screws of the cabinet.</p> <p>(2) Hold the bottom of the cabinet on the both side to remove the cabinet.</p>	<p>Photo 1</p>  <p>Service panel</p> <p>Screws</p> <p>Photo 2</p>  <p>Screws</p>
<p>2. Removing the electrical parts</p> <p>(1) Remove the cabinet . (Refer to 1.)</p> <p>(2) Remove the following parts.</p> <ul style="list-style-type: none"> •Compressor capacitor (C1) •Outdoor fan capacitor (C2) •Terminal block(TB1, TB2) •Relay (X1) •Compressor contactor (52C) 	<p>Photo 3</p>  <p>Outdoor fan capacitor (C2)</p> <p>Connector</p> <p>Relay (X1)</p> <p>Compressor capacitor (C1)</p> <p>Compressor contactor (52C)</p> <p>Terminal blocks (TB1, TB2)</p>

OPERATING PROCEDURE

3. Removing the outdoor fan motor

- (1) Remove the cabinet. (Refer to 1.)
- (2) Disconnect the connector and remove the hooked lead wire from the fan motor.
- (3) Remove the propeller nut and remove the propeller.
- (4) Remove the screws fixing the fan motor.
- (5) Remove the outdoor fan motor.

4. Removing the compressor

- (1) Remove the cabinet. (Refer to 1.)
- (2) Remove the soundproof felt.
- (3) Remove the terminal cover on the compressor.
- (4) Disconnect the lead wires from the glass terminal of the compressor.
- (5) Recover gas from the refrigerant circuit.
- (6) Disconnect the welded part of the discharge pipe.
- (7) Disconnect the welded part of the suction pipe.
- (8) Remove nuts fixing the compressor.
- (9) Remove the compressor.

NOTE

- Before using a burner, reclaim gas from the pipes until the pressure gauge shows 0 kg/cm² (0MPa).
- Use the burner under the condition that gas can be recovered even when the inner pressure rises by heat.

PHOTOS

Photo 4

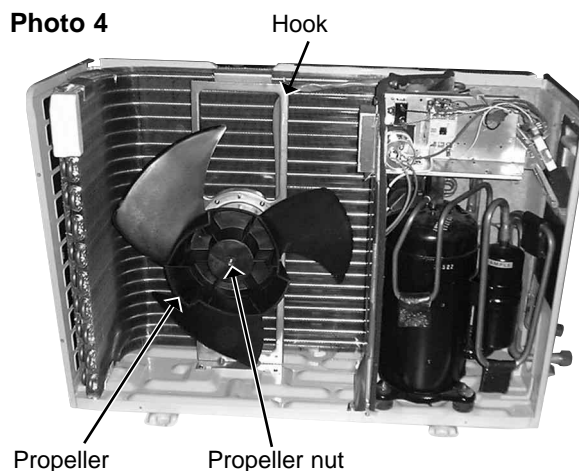
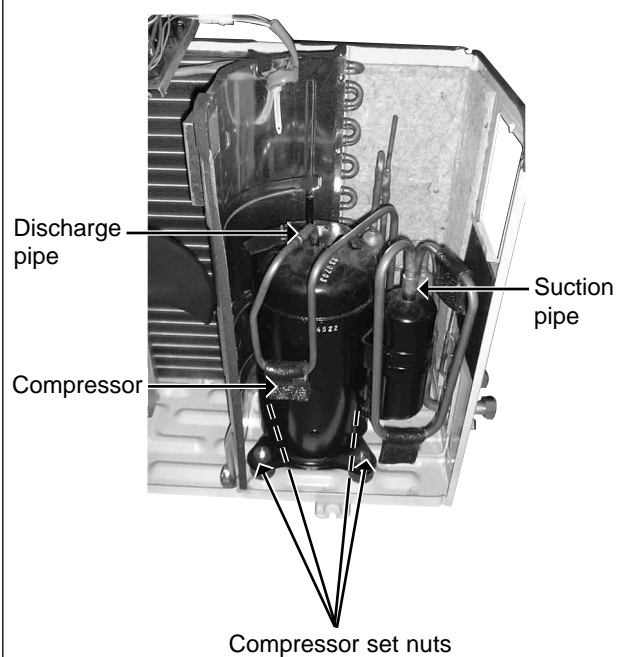
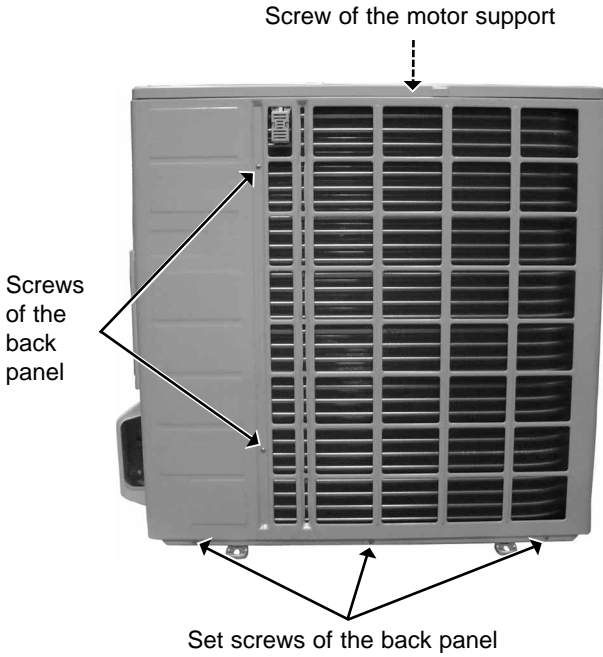
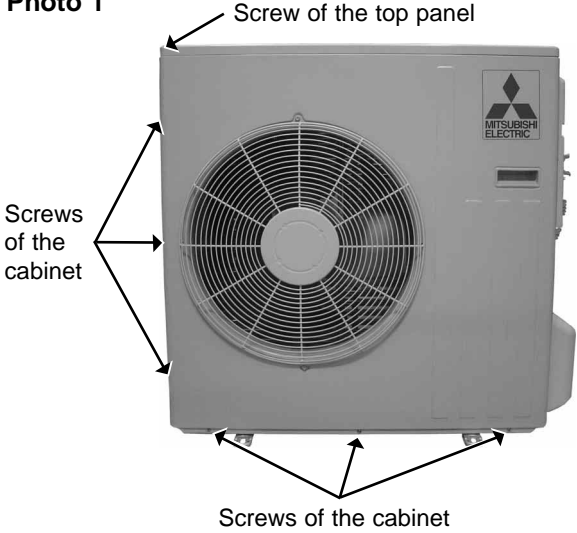
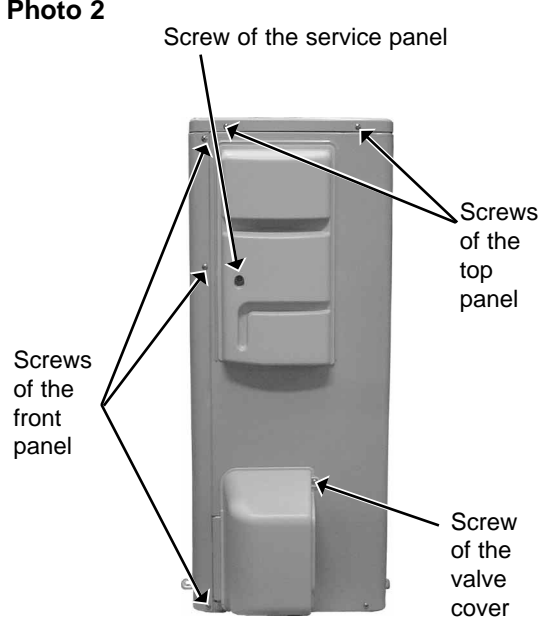
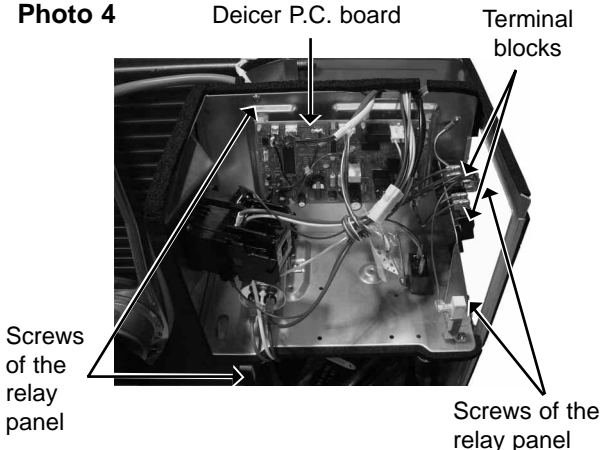

Photo 5



11-3. MU-A30WV -E1
OUTDOOR UNIT

OPERATING PROCEDURE	PHOTOS
<p>1. Removing the cabinet</p> <ol style="list-style-type: none"> (1) Remove the screws of the service panel. (2) Remove the screws of the top panel. (3) Remove the screw of the valve cover. (4) Remove the service panel. (5) Remove the top panel. (6) Remove the valve cover. (7) Remove the screws of the front panel. (8) Remove the front panel. (9) Remove the screws of the back panel. (10) Remove the back panel. <p>Photo 3</p> 	<p>Photo 1</p>  <p>Photo 2</p> 
<p>2. Removing the deicer P.C. board</p> <ol style="list-style-type: none"> (1) Remove the service panel and the cabinet. (2) Disconnect all the connectors and the terminals on the deicer P.C. board. (3) Remove the deicer P.C. board. 	<p>Photo 4</p> 

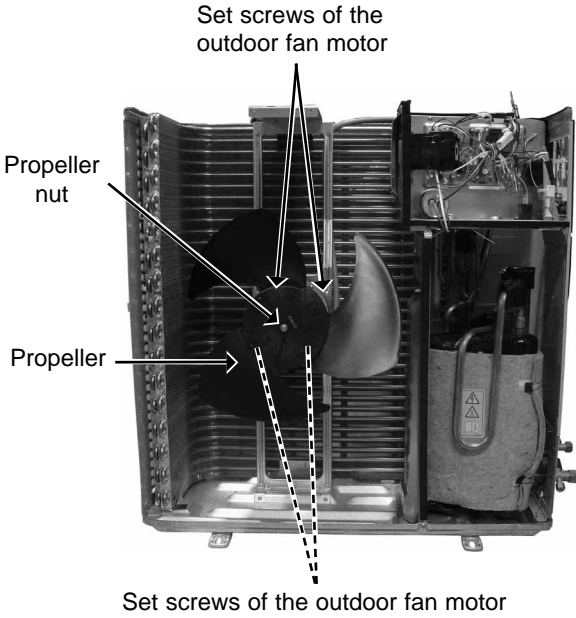
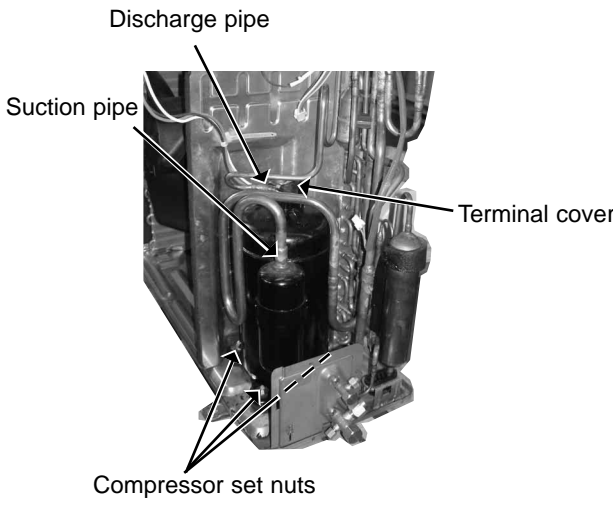

OPERATING PROCEDURE	PHOTOS
<p>3. Removing the propeller and the outdoor fan motor</p> <p>(1) Remove the cabinet. (Refer to 1.)</p> <p>(2) Remove the propeller nut and the propeller.</p> <p>NOTE : Loose the propeller in the rotating direction for removal.</p> <p>When attaching the propeller, align the mark on the propeller and the motor shaft cut section.</p> <p>Set the propeller in position by using the cut on the shaft and the mark on the propeller.</p> <p>(3) Remove the clamp of outdoor fan motor lead wire and disconnect the outdoor fan motor connector.</p> <p>(4) Remove the screws fixing the outdoor fan motor.</p> <p>(5) Remove the outdoor fan motor.</p>	<p>Photo 5</p>  <p>Set screws of the outdoor fan motor</p> <p>Propeller nut</p> <p>Propeller</p> <p>Set screws of the outdoor fan motor</p>
<p>4. Removing the compressor</p> <p>(1) Remove the cabinet. (Refer to 1.)</p> <p>(2) Remove the relay panel.</p> <p>(3) Remove the soundproof felt.</p> <p>(4) Remove the terminal cover on the compressor.</p> <p>(5) Disconnect lead wires from the compressor.</p> <p>(6) Recover gas from the refrigerant circuit.</p> <p>(7) Disconnect the welded part of the discharge pipe.</p> <p>(8) Disconnect the welded part of the suction pipe.</p> <p>(9) Remove nuts fixing the compressor.</p> <p>(10) Remove the compressor.</p> <p>NOTE</p> <ul style="list-style-type: none">● Before using a burner, reclaim gas from the pipes until the pressure gauge shows 0 kg/cm² (0 MPa).● Use the burner under the condition that gas can be recovered even when the inner pressure rises by heat.	<p>Photo 6</p>  <p>Discharge pipe</p> <p>Suction pipe</p> <p>Terminal cover</p> <p>Compressor set nuts</p>

MU-A18WV -[E1]

MU-A24WV -[E1]

12-1. OUTDOOR UNIT

STRUCTURAL PARTS, ELECTRICAL PARTS AND FUNCTIONAL PARTS

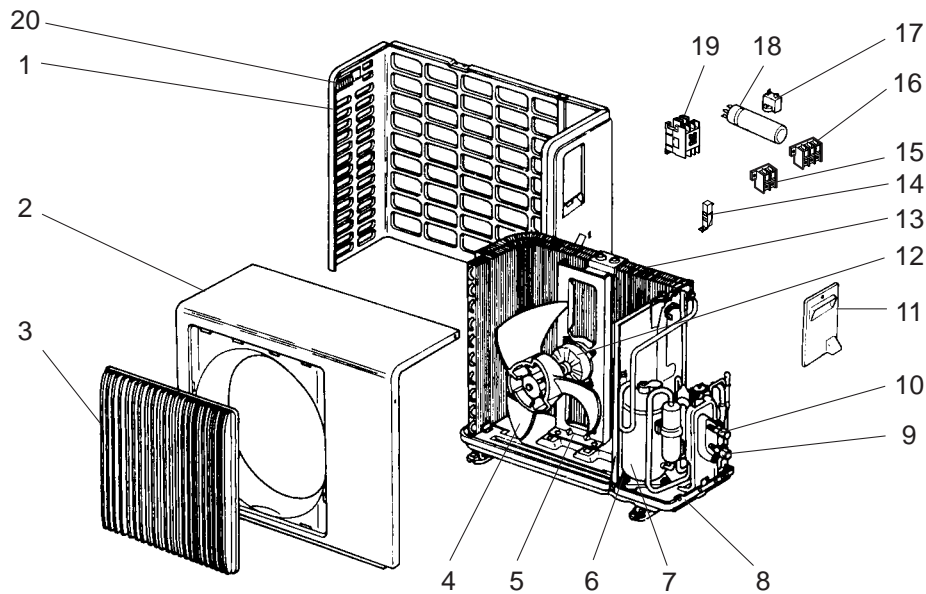

Part numbers that are circled are not shown in the illustration.

No.	Part No.	Part Name	Symbol in Wiring Diagram	Q'ty/unit		Remarks
				MU-A18WV-[E1]	MU-A24WV-[E1]	
1	E02 817 233	BACK PANEL		1	1	
2	E02 817 232	CABINET		1	1	
3	E02 817 521	GRILLE		1	1	
4	E02 141 501	PROPELLER		1	1	
5	E02 139 515	MOTOR SUPPORT		1	1	
6	E02 075 506	COMPRESSOR RUBBER SET		3		3RUBBERS/SET
	E02 527 506	COMPRESSOR RUBBER SET			4	4RUBBERS/SET
7	E02 817 900	COMPRESSOR	MC	1		RN196VHSHT
	E02 821 900	COMPRESSOR	MC		1	NN29VBAHT
8	E02 817 290	BASE		1		
	E02 818 290	BASE			1	
9	E02 817 661	STOP VALVE(GAS)		1		φ12.7
	E02 818 661	STOP VALVE(GAS)			1	φ15.88
10	E02 817 662	STOP VALVE(LIQUID)		1	1	φ 6.35
11	E02 817 245	SERVICE PANEL		1	1	
12	E02 144 301	OUTDOOR FAN MOTOR	MF	1		RA6V50 - <input type="checkbox"/>
	E02 818 301	OUTDOOR FAN MOTOR	MF		1	RA6V60 - <input type="checkbox"/>
13	E02 817 630	OUTDOOR HEAT EXCHANGER		1		
	E02 818 630	OUTDOOR HEAT EXCHANGER			1	
14	E02 466 383	SURGE ABSORBER	DSAR	1	1	
15	E02 818 374	TERMINAL BLOCK	TB2	1	1	2P
16	E02 817 374	TERMINAL BLOCK	TB1	1	1	3P
17	E02 138 351	OUTDOOR FAN CAPACITOR	C2	1	1	3.0μF/440V AC
18	E02 817 353	COMPRESSOR CAPACITOR	C1	1		40μF/440V AC
	E02 818 353	COMPRESSOR CAPACITOR	C1		1	55μF/440V AC
19	E07 012 340	COMPRESSOR CONTACTOR	52C		1	
20	E02 817 009	HANDLE		1	1	
⑳	E02 412 936	CAPILLARY TUBE		1		φ3.0×φ1.6×600
	E02 076 936	CAPILLARY TUBE			1	φ3.0×φ2.0×900
	E02 820 936	CAPILLARY TUBE		1		φ2.5×φ0.6×1000
㉑	E02 466 340	COMPRESSOR CONTACTOR	52C	1		
㉒	E02 466 340	RELAY	X1		1	

MU-A30WV -E1

12-2. OUTDOOR UNIT STRUCTURAL PARTS, ELECTRICAL PARTS AND FUNCTIONAL PARTS

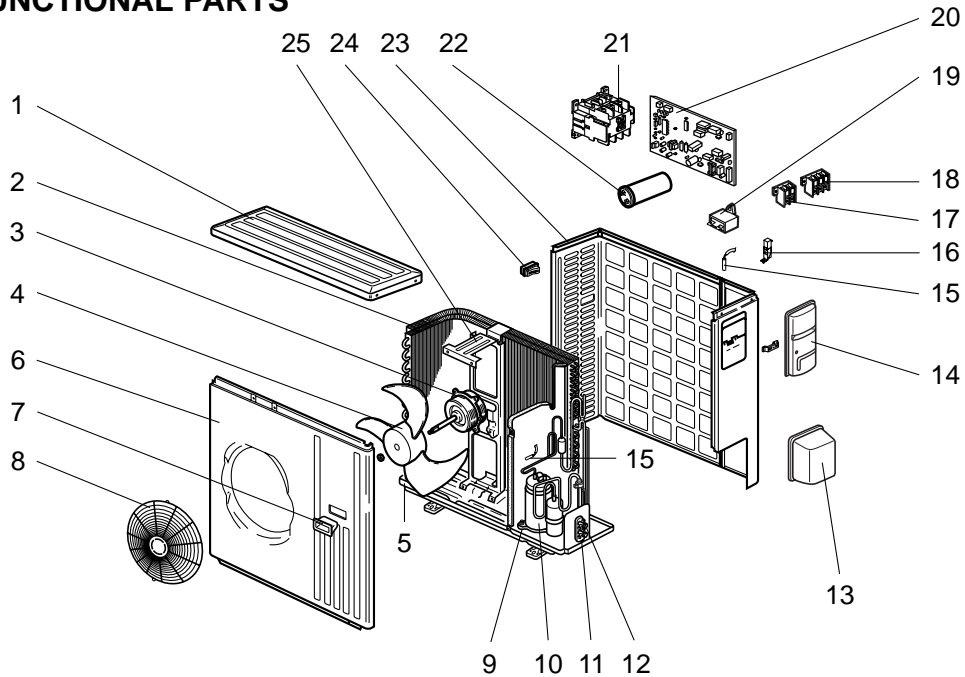

Part numbers that are circled are not shown in the illustration.

No.	Part No.	Part Name	Symbol in Wiring Diagram	Q'ty/unit	Remarks
				MU-A30WV -E1	
1	E02 819 297	TOP PANEL		1	
2	E02 819 630	OUTDOOR HEAT EXCHANGER		1	
3	E02 819 301	OUTDOOR FAN MOTOR	MF	1	RA6V75- □□
4	E02 214 501	PROPELLER		1	
5	E02 819 290	BASE		1	
6	E02 819 232	CABINET		1	
7	E02 819 009	HANDLE		1	
8	E02 819 521	FAN GUARD		1	
9	E02 527 506	COMPRESSOR RUBBER SET		4	4RUBBERS/SET
10	E02 819 900	COMPRESSOR	MC	1	NN37VAAHT
11	E02 819 661	STOP VALVE(GAS)		1	φ15.88
12	E02 819 662	STOP VALVE(LIQUID)		1	φ9.52
13	E02 819 650	VALVE COVER		1	
14	E02 819 245	SERVICE PANEL		1	
15	E02 819 309	THERMISTOR	RT62, RT63	1	DISCHARGE, AMBIENT
16	E02 128 383	SURGE ABSORBER	DSAR	1	
17	E02 821 374	TERMINAL BLOCK	TB2	1	2P
18	E02 817 374	TERMINAL BLOCK	TB1	1	3P
19	E02 064 351	OUTDOOR FAN CAPACITOR	C2	1	4.0μF/440V AC
20	E02 819 451	DEICER P.C. BOARD		1	
21	E02 819 340	COMPRESSOR CONTACTOR	52C	1	
22	E02 819 353	COMPRESSOR CAPACITOR	C1	1	60μF/440V AC
23	E02 819 233	BACK PANEL(OUT)		1	
24	E02 817 009	HANDLE		1	
25	E02 726 515	MOTOR SUPPORT		1	
26	E02 822 640	EXPANSION VALVE		1	
27	E02 819 493	EXPANSION VALVE COIL	LEV	1	
28	E02 127 382	FUSE	F61	1	250V/3.15A
29	E02 336 385	VARISTOR	NR61	1	
30	E02 214 386	CZ SURGE ABSORBER	CZ	1	
31	E02 819 936	CAPILLARY TUBE(TAPER PIPE)		1	φ3.6xφ2.4x50
32	E02 262 936	CAPILLARY TUBE		1	φ4.0xφ2.4x200
33	E02 527 936	CAPILLARY TUBE		1	φ4.0xφ2.4x100



HEAD OFFICE: MITSUBISHI DENKI BLDG.,2-2-3, MARUNOUCHI, CHIYODA-KU, TOKYO100-8310, JAPAN

© Copyright 2003 MITSUBISHI ELECTRIC ENGINEERING CO.,LTD
Distributed in Feb. 2004. No.OB326 REVISED EDITION-A 6
Distributed in Dec. 2003. No.OB326 6
Made in Japan

New publication, effective Feb. 2004
Specifications subject to change without notice.