

Revision A:

- Resistance of LEV (Expansion valve) has been modified.
- Power input and others have been added to SPECIFICATION.

Please void OB326.

No. OB326
REVISED EDITION-A



SERVICE MANUAL

Wireless type
Models

- MU-A18WV** ■ E1
- MU-A24WV** ■ E1
- MU-A30WV** ■ E1

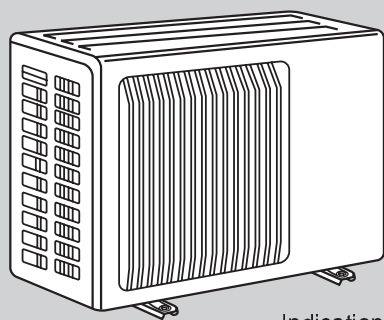

Indication of model name
MU-A18WV ■ E1

CONTENTS

1. TECHNICAL CHANGES	2
2. PART NAMES AND FUNCTIONS	5
3. SPECIFICATION	5
4. NOISE CRITERIA CURVES	7
5. OUTLINES AND DIMENSIONS	8
6. WIRING DIAGRAM	9
7. REFRIGERANT SYSTEM DIAGRAM	11
8. PERFORMANCE CURVES	14
9. MICROPROCESSOR CONTROL	22
10. TROUBLESHOOTING	25
11. DISASSEMBLY INSTRUCTIONS	32
12. PARTS LIST	38

NOTE:

•This service manual describes technical data of outdoor units.
As for indoor units MS-A18WV-**E1**, MS-A24WV-**E1** and MS-A30WV-**E1**, refer to the service manual OB325.



<"Terminal with lock mechanism" Detaching points>

In case of terminal with lock mechanism, detach the terminal as shown below.
There are two types (Refer to (1) and (2)) of the terminal with lock mechanism.
The terminal with no lock mechanism can be removed by pulling it out.
Check the shape of the terminal and work.

(1) Slide the sleeve and check if there is a locking lever or not.

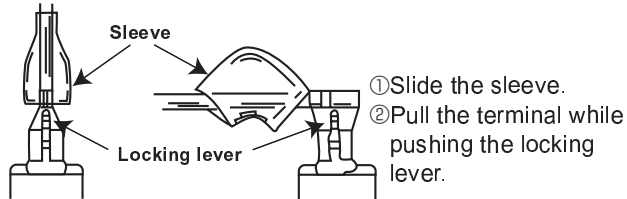

(2) The terminal with this connector is a terminal with lock mechanism

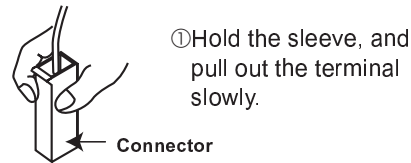

11-1. MU-A18W -E1 OUTDOOR UNIT

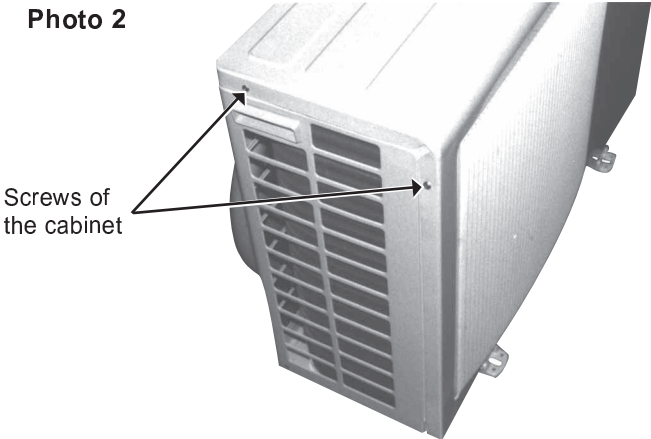
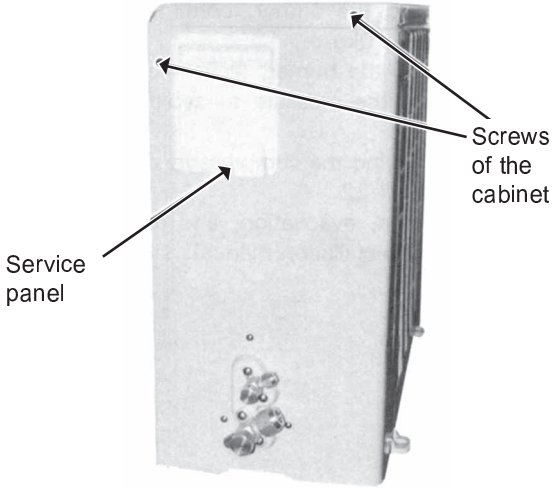
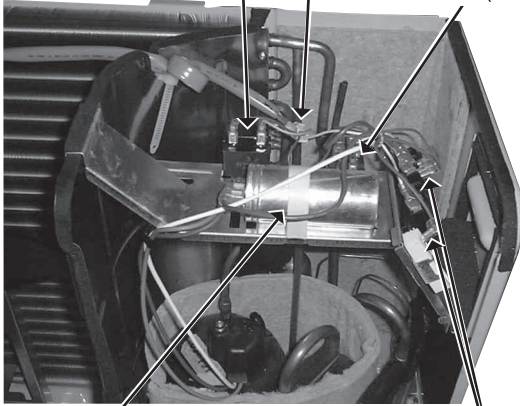
OPERATING PROCEDURE	PHOTOS
<p>1. Removing the cabinet</p> <p>(1) Remove the screws of the cabinet. (2) Hold the down of the cabinet on the both side and remove the cabinet.</p> <p>Photo 2</p>  <p>Screws of the cabinet</p>	<p>Photo 1</p>  <p>Service panel</p> <p>Screws of the cabinet</p>
<p>2. Removing the electrical parts</p> <p>(1) Remove the service panel and the cabinet. (2) Remove the following parts.</p> <ul style="list-style-type: none"> •Compressor capacitor (C1) •Outdoor fan capacitor (C2) •Terminal block (TB1, TB2) •Compressor contactor (52C) 	<p>Photo 3</p>  <p>Outdoor fan capacitor(C2)</p> <p>Connector</p> <p>Compressor contactor(52C)</p> <p>Compressor capacitor(C1)</p> <p>Terminal blocks (TB1, TB2)</p>

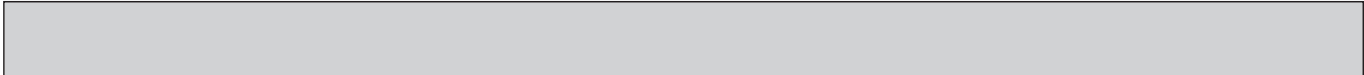

OPERATING PROCEDURE

3. Removing the outdoor fan motor

- (1) Remove the cabinet. (Refer to 1.)
- (2) Disconnect the connector and remove the hooked lead wire from the fan motor.
- (3) Remove the propeller nut and remove the propeller.
- (4) Remove screws fixing the outdoor fan motor.
- (5) Remove the outdoor fan motor.

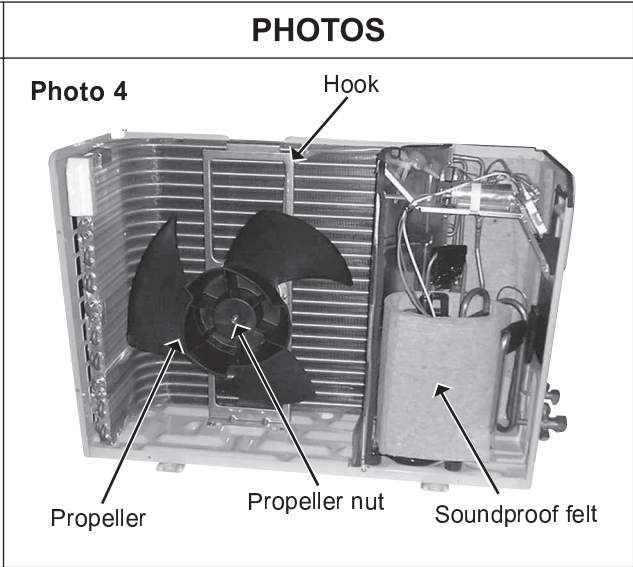

4. Removing the compressor

- (1) Remove the cabinet. (Refer to 1.)
- (2) Remove the relay panel.
- (3) Remove the soundproof felt.
- (4) Remove the terminal cover on the compressor.
- (5) Disconnect lead wires from the glass terminal of the compressor.
- (6) Recover gas from the refrigerant circuit.
- (7) Disconnect the welded part of the discharge pipe.
- (8) Disconnect the welded part of the suction pipe.
- (9) Remove nuts fixing the compressor.
- (10) Remove the compressor.

NOTE

- Before using a burner, reclaim gas from the pipes until the pressure gauge shows 0 kg/cm² (MPa).
- Use the burner under the condition that gas can be recovered even when the inner pressure rises by heat.

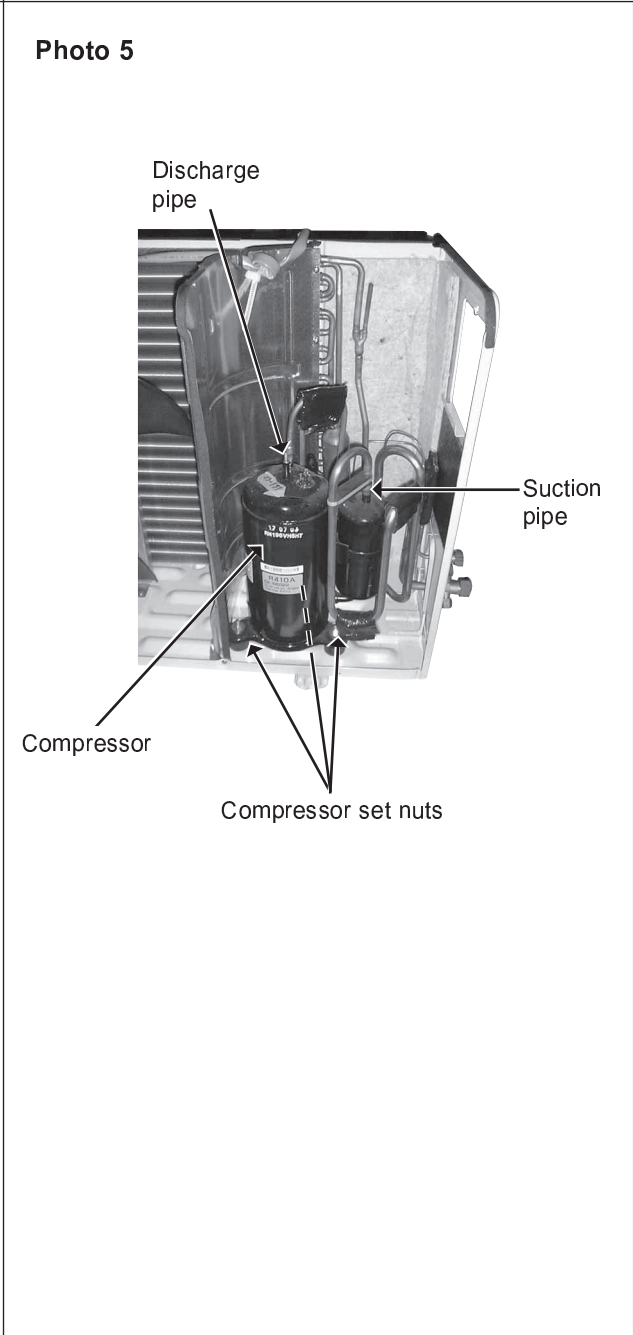

11-2. MU-A24WV -E1
OUTDOOR UNIT

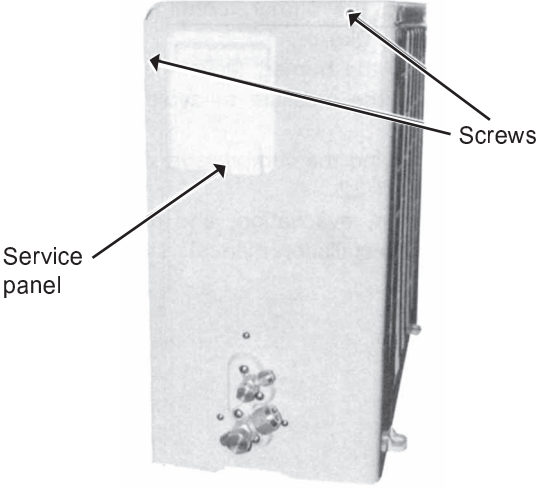
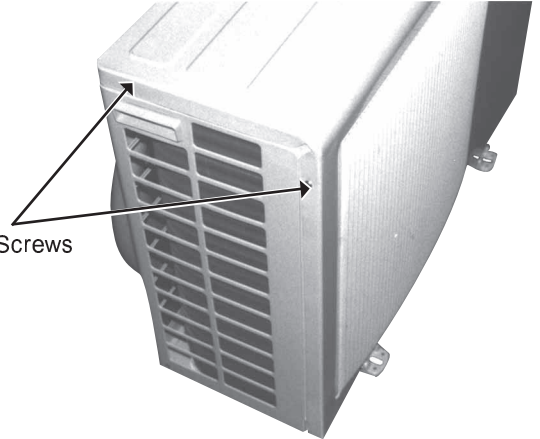
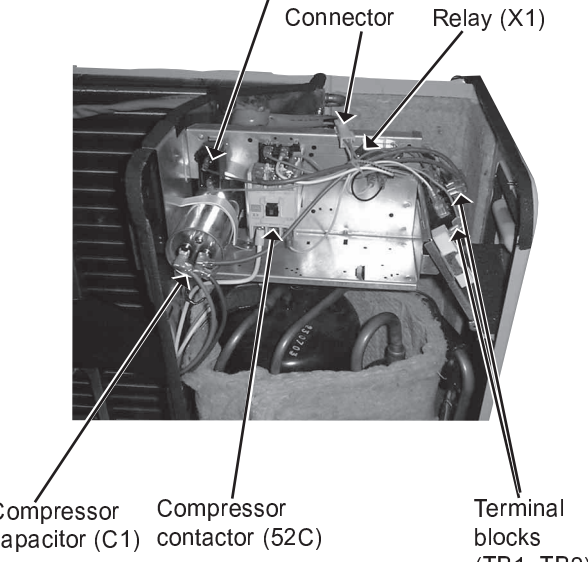
OPERATING PROCEDURE	PHOTOS
<p>1. Removing the cabinet</p> <p>(1) Remove the screws of the cabinet.</p> <p>(2) Hold the bottom of the cabinet on the both side to remove the cabinet.</p>	<p>Photo 1</p>  <p>Photo 2</p> 
<p>2. Removing the electrical parts</p> <p>(1) Remove the cabinet . (Refer to 1.)</p> <p>(2) Remove the following parts.</p> <ul style="list-style-type: none"> •Compressor capacitor (C1) •Outdoor fan capacitor (C2) •Terminal block(TB1, TB2) •Relay (X1) •Compressor contactor (52C) 	<p>Photo 3</p> 



OPERATING PROCEDURE

- 3. Removing the outdoor fan motor**
- (1) Remove the cabinet. (Refer to 1.)
 - (2) Disconnect the connector and remove the hooked lead wire from the fan motor.
 - (3) Remove the propeller nut and remove the propeller.
 - (4) Remove the screws fixing the fan motor.
 - (5) Remove the outdoor fan motor.

PHOTOS

Photo 4

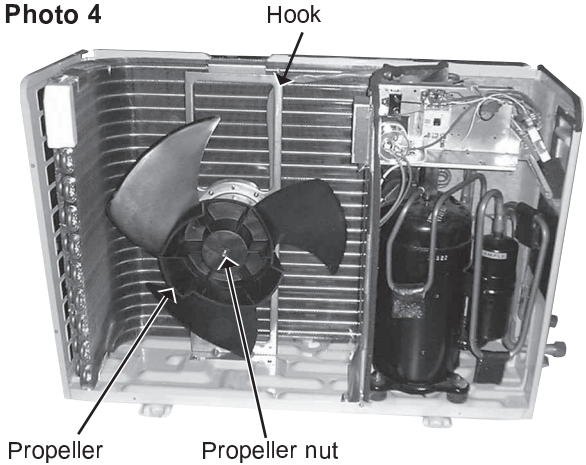

- 4. Removing the compressor**
- (1) Remove the cabinet. (Refer to 1.)
 - (2) Remove the soundproof felt.
 - (3) Remove the terminal cover on the compressor.
 - (4) Disconnect the lead wires from the glass terminal of the compressor.
 - (5) Recover gas from the refrigerant circuit.
 - (6) Disconnect the welded part of the discharge pipe.
 - (7) Disconnect the welded part of the suction pipe.
 - (8) Remove nuts fixing the compressor.
 - (9) Remove the compressor.

NOTE

- Before using a burner, reclaim gas from the pipes until the pressure gauge shows 0 kg/cm² (0MPa).
- Use the burner under the condition that gas can be recovered even when the inner pressure rises by heat.

Photo 5

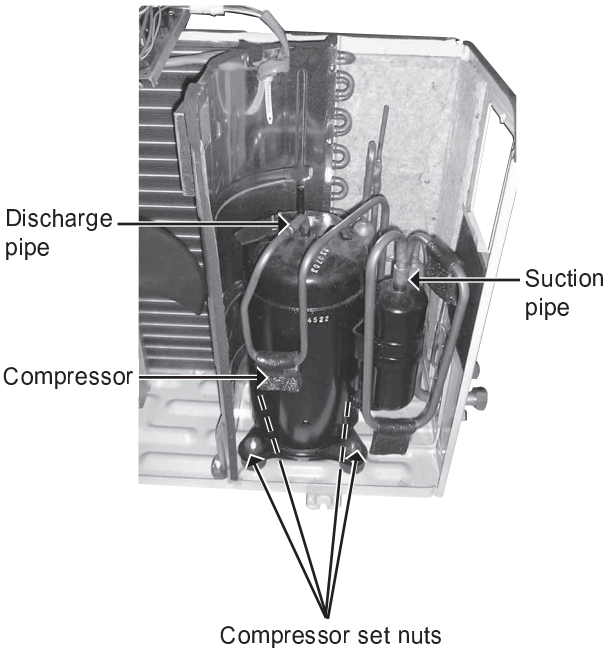

11-3. MU-A30WV -E1
OUTDOOR UNIT

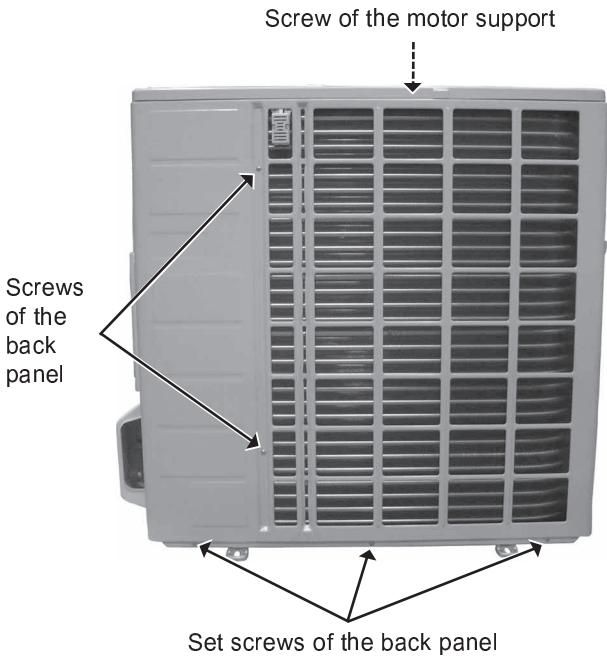
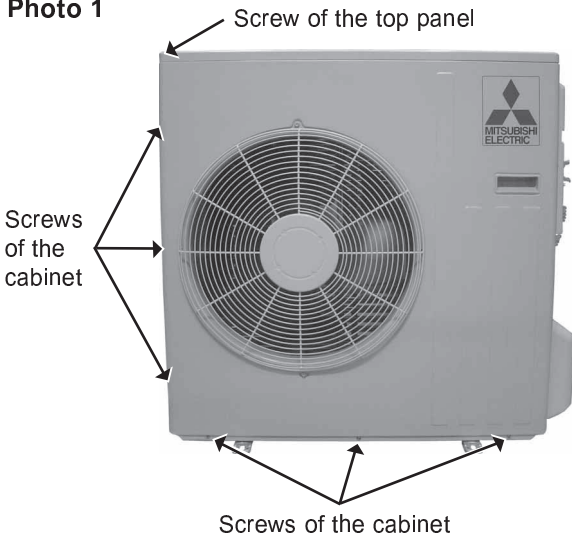
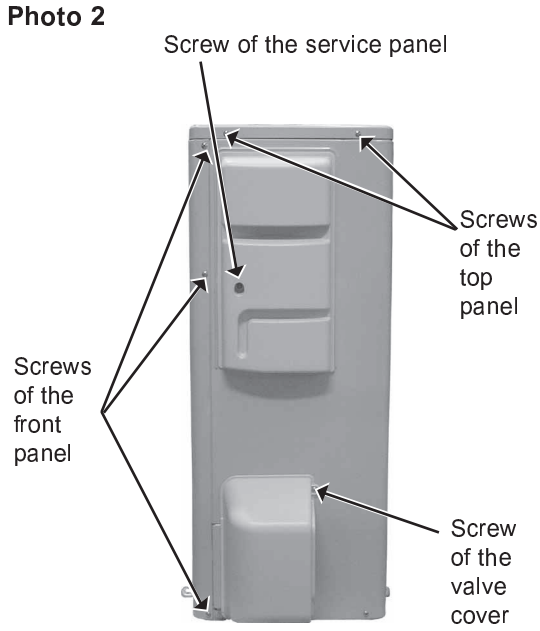
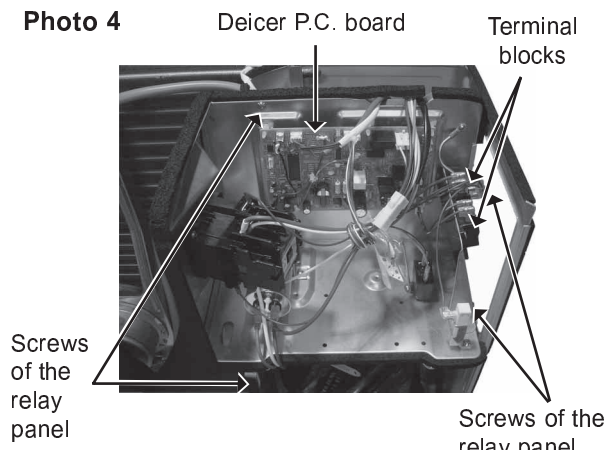
OPERATING PROCEDURE	PHOTOS
<p>1. Removing the cabinet</p> <ol style="list-style-type: none"> (1) Remove the screws of the service panel. (2) Remove the screws of the top panel. (3) Remove the screw of the valve cover. (4) Remove the service panel. (5) Remove the top panel. (6) Remove the valve cover. (7) Remove the screws of the front panel. (8) Remove the front panel. (9) Remove the screws of the back panel. (10) Remove the back panel. <p>Photo 3</p> 	<p>Photo 1</p>  <p>Photo 2</p> 
<p>2. Removing the deicer P.C. board</p> <ol style="list-style-type: none"> (1) Remove the service panel and the cabinet. (2) Disconnect all the connectors and the terminals on the deicer P.C. board. (3) Remove the deicer P.C. board. 	<p>Photo 4</p> 

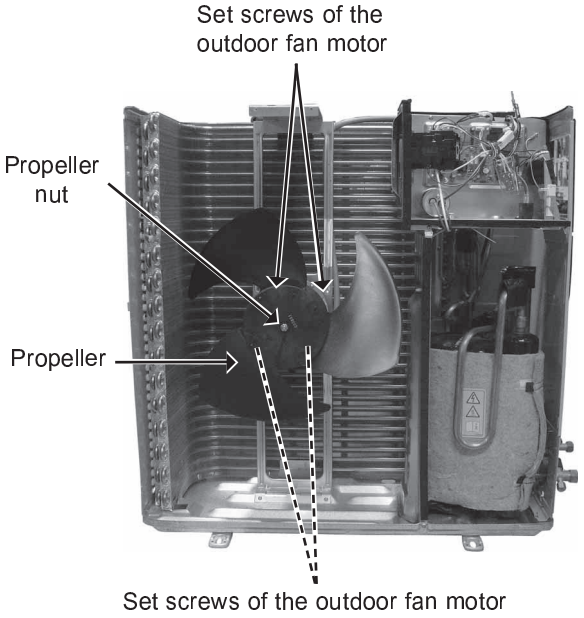
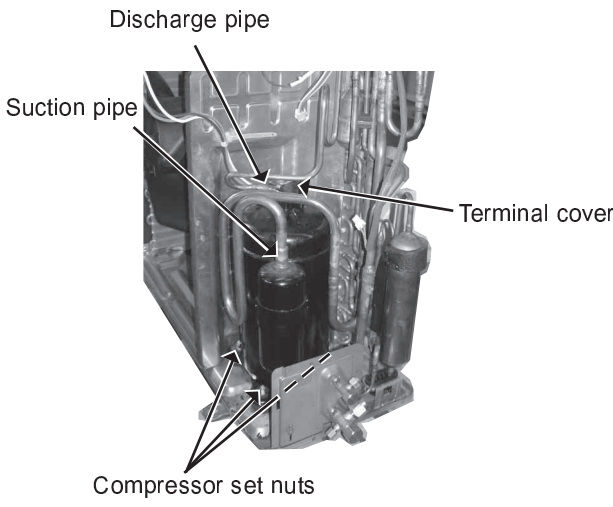

OPERATING PROCEDURE	PHOTOS
<p>3. Removing the propeller and the outdoor fan motor</p> <p>(1) Remove the cabinet. (Refer to 1.)</p> <p>(2) Remove the propeller nut and the propeller.</p> <p>NOTE : Loose the propeller in the rotating direction for removal.</p> <p>When attaching the propeller, align the mark on the propeller and the motor shaft cut section.</p> <p>Set the propeller in position by using the cut on the shaft and the mark on the propeller.</p> <p>(3) Remove the clamp of outdoor fan motor lead wire and disconnect the outdoor fan motor connector.</p> <p>(4) Remove the screws fixing the outdoor fan motor.</p> <p>(5) Remove the outdoor fan motor.</p>	<p>Photo 5</p>  <p>Set screws of the outdoor fan motor</p> <p>Propeller nut</p> <p>Propeller</p> <p>Set screws of the outdoor fan motor</p>
<p>4. Removing the compressor</p> <p>(1) Remove the cabinet. (Refer to 1.)</p> <p>(2) Remove the relay panel.</p> <p>(3) Remove the soundproof felt.</p> <p>(4) Remove the terminal cover on the compressor.</p> <p>(5) Disconnect lead wires from the compressor.</p> <p>(6) Recover gas from the refrigerant circuit.</p> <p>(7) Disconnect the welded part of the discharge pipe.</p> <p>(8) Disconnect the welded part of the suction pipe.</p> <p>(9) Remove nuts fixing the compressor.</p> <p>(10) Remove the compressor.</p> <p>NOTE</p> <ul style="list-style-type: none">● Before using a burner, reclaim gas from the pipes until the pressure gauge shows 0 kg/cm² (0 MPa).● Use the burner under the condition that gas can be recovered even when the inner pressure rises by heat.	<p>Photo 6</p>  <p>Discharge pipe</p> <p>Suction pipe</p> <p>Terminal cover</p> <p>Compressor set nuts</p>

MU-A18WV -E1

MU-A24WV -E1

12-1. OUTDOOR UNIT

STRUCTURAL PARTS, ELECTRICAL PARTS AND FUNCTIONAL PARTS

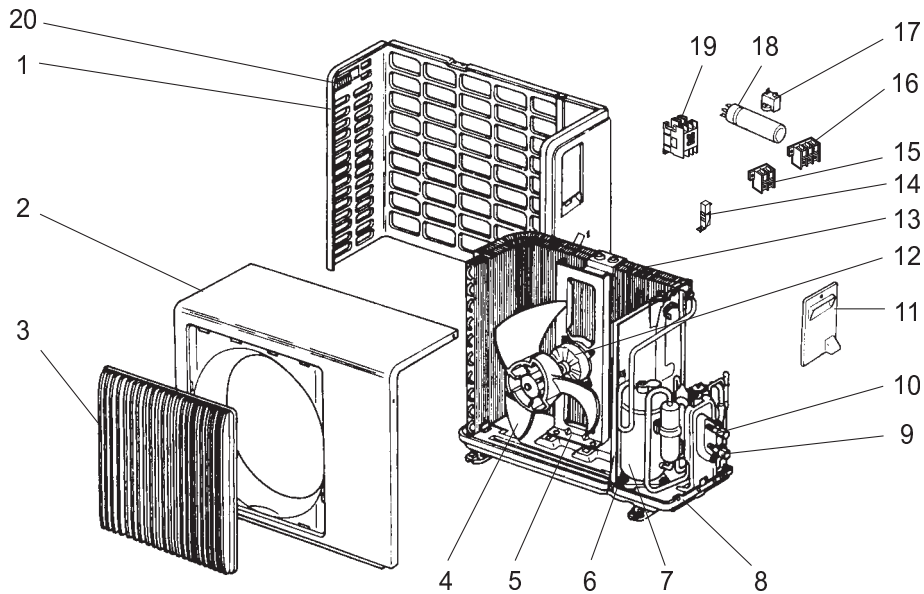

Part numbers that are circled are not shown in the illustration.

No.	Part No.	Part Name	Symbol in Wiring Diagram	Q'ty/unit		Remarks
				MU-A18WV-E1	MU-A24WV-E1	
1	E02 817 233	BACK PANEL		1	1	
2	E02 817 232	CABINET		1	1	
3	E02 817 521	GRILLE		1	1	
4	E02 141 501	PROPELLER		1	1	
5	E02 139 515	MOTOR SUPPORT		1	1	
6	E02 075 506	COMPRESSOR RUBBER SET		3		3RUBBERS/SET
	E02 527 506	COMPRESSOR RUBBER SET			4	4RUBBERS/SET
7	E02 817 900	COMPRESSOR	MC	1		RN196VHSHT
	E02 821 900	COMPRESSOR	MC		1	NN29VBAHT
8	E02 817 290	BASE		1		
	E02 818 290	BASE			1	
9	E02 817 661	STOP VALVE(GAS)		1		φ12.7
	E02 818 661	STOP VALVE(GAS)			1	φ15.88
10	E02 817 662	STOP VALVE(LIQUID)		1	1	φ 6.35
11	E02 817 245	SERVICE PANEL		1	1	
12	E02 144 301	OUTDOOR FAN MOTOR	MF	1		RA6V50 - <input type="checkbox"/>
	E02 818 301	OUTDOOR FAN MOTOR	MF		1	RA6V60 - <input type="checkbox"/>
13	E02 817 630	OUTDOOR HEAT EXCHANGER		1		
	E02 818 630	OUTDOOR HEAT EXCHANGER			1	
14	E02 466 383	SURGE ABSORBER	DSAR	1	1	
15	E02 818 374	TERMINAL BLOCK	TB2	1	1	2P
16	E02 817 374	TERMINAL BLOCK	TB1	1	1	3P
17	E02 138 351	OUTDOOR FAN CAPACITOR	C2	1	1	3.0μF/440V AC
18	E02 817 353	COMPRESSOR CAPACITOR	C1	1		40μF/440V AC
	E02 818 353	COMPRESSOR CAPACITOR	C1		1	55μF/440V AC
19	E07 012 340	COMPRESSOR CONTACTOR	52C		1	
20	E02 817 009	HANDLE		1	1	
21	E02 412 936	CAPILLARY TUBE		1		φ3.0×φ1.6×600
	E02 076 936	CAPILLARY TUBE			1	φ3.0×φ2.0×900
	E02 820 936	CAPILLARY TUBE		1		φ2.5×φ0.6×1000
22	E02 466 340	COMPRESSOR CONTACTOR	52C	1		
23	E02 466 340	RELAY	X1		1	

MU-A30WV -E1

12-2. OUTDOOR UNIT STRUCTURAL PARTS, ELECTRICAL PARTS AND FUNCTIONAL PARTS

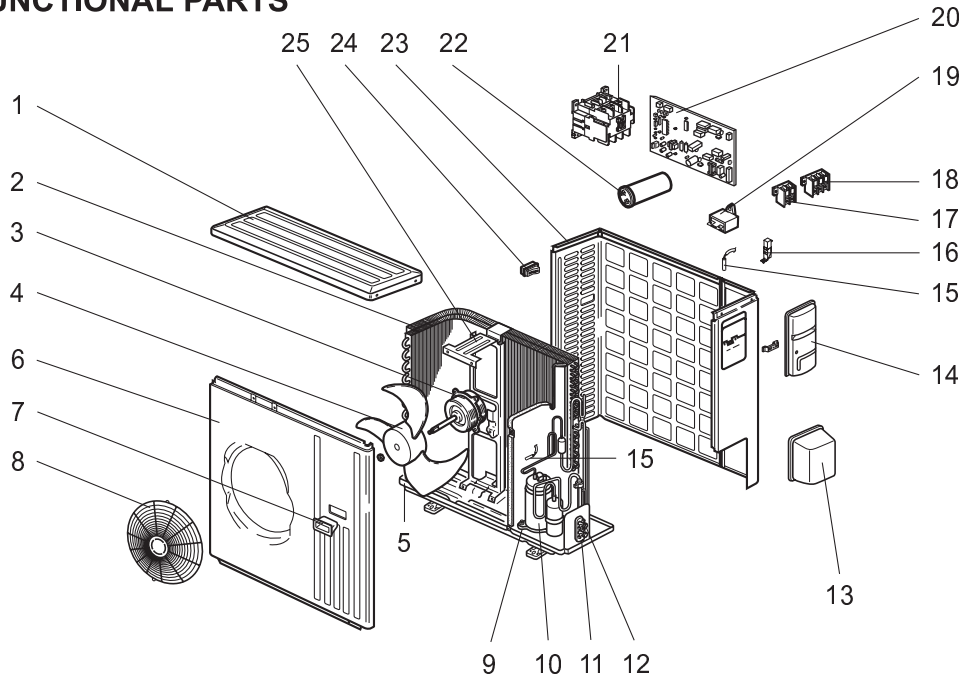

Part numbers that are circled are not shown in the illustration.

No.	Part No.	Part Name	Symbol in Wiring Diagram	Q'ty/unit	Remarks
				MU-A30WV -E1	
1	E02 819 297	TOP PANEL		1	
2	E02 819 630	OUTDOOR HEAT EXCHANGER		1	
3	E02 819 301	OUTDOOR FAN MOTOR	MF	1	RA6V75- □□
4	E02 214 501	PROPELLER		1	
5	E02 819 290	BASE		1	
6	E02 819 232	CABINET		1	
7	E02 819 009	HANDLE		1	
8	E02 819 521	FAN GUARD		1	
9	E02 527 506	COMPRESSOR RUBBER SET		4	4RUBBERS/SET
10	E02 819 900	COMPRESSOR	MC	1	NN37VAAHT
11	E02 819 661	STOP VALVE(GAS)		1	φ15.88
12	E02 819 662	STOP VALVE(LIQUID)		1	φ9.52
13	E02 819 650	VALVE COVER		1	
14	E02 819 245	SERVICE PANEL		1	
15	E02 819 309	THERMISTOR	RT62, RT63	1	DISCHARGE, AMBIENT
16	E02 128 383	SURGE ABSORBER	DSAR	1	
17	E02 821 374	TERMINAL BLOCK	TB2	1	2P
18	E02 817 374	TERMINAL BLOCK	TB1	1	3P
19	E02 064 351	OUTDOOR FAN CAPACITOR	C2	1	4.0μF/440V AC
20	E02 819 451	DEICER P.C. BOARD		1	
21	E02 819 340	COMPRESSOR CONTACTOR	52C	1	
22	E02 819 353	COMPRESSOR CAPACITOR	C1	1	60μF/440V AC
23	E02 819 233	BACK PANEL(OUT)		1	
24	E02 817 009	HANDLE		1	
25	E02 726 515	MOTOR SUPPORT		1	
26	E02 822 640	EXPANSION VALVE		1	
27	E02 819 493	EXPANSION VALVE COIL	LEV	1	
28	E02 127 382	FUSE	F61	1	250V/3.15A
29	E02 336 385	VARISTOR	NR61	1	
30	E02 214 386	CZ SURGE ABSORBER	CZ	1	
31	E02 819 936	CAPILLARY TUBE(TAPER PIPE)		1	φ3.6xφ2.4x50
32	E02 262 936	CAPILLARY TUBE		1	φ4.0xφ2.4x200
33	E02 527 936	CAPILLARY TUBE		1	φ4.0xφ2.4x100



HEAD OFFICE: MITSUBISHI DENKI BLDG., 2-2-3, MARUNOUCHI, CHIYODA-KU, TOKYO100-8310, JAPAN

© Copyright 2003 MITSUBISHI ELECTRIC ENGINEERING CO.,LTD
Distributed in Feb. 2004. No.OB326 REVISED EDITION-A 6
Distributed in Dec. 2003. No.OB326 6
Made in Japan

New publication, effective Feb. 2004
Specifications subject to change without notice.