

Revision A:

- MU-A12YV -[E1] can be connected to MCF-A12WV -[E1].

Please void OB330.

No. OB330
REVISED EDITION-A



SERVICE MANUAL

**Wireless type
Models**

- MU-A07YV** -[E1]
- MU-A09YV** -[E1]
- MU-A12YV** -[E1]

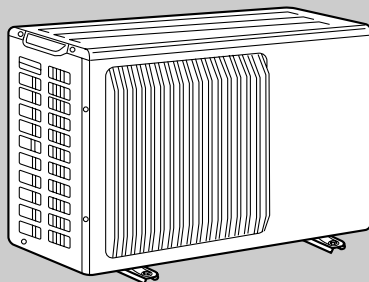

Indication of
model name

- MU-A07YV** -[E1]
- MU-A09YV** -[E1]
- MU-A12YV** -[E1]

CONTENTS

1. TECHNICAL CHANGES	2
2. PART NAMES AND FUNCTIONS.....	5
3. SPECIFICATION.....	5
4. NOISE CRITERIA CURVES	6
5. OUTLINES AND DIMENSIONS	7
6. WIRING DIAGRAM	7
7. REFRIGERANT SYSTEM DIAGRAM	8
8. PERFORMANCE CURVES	9
9. TROUBLESHOOTING.....	20
10. DISASSEMBLY INSTRUCTIONS.....	23
11. PARTS LIST.....	26

NOTE:

- This service manual describes technical data of outdoor units.
- As for indoor units MSC-A07YV -[E1], MSC-A09YV -[E1] and MSC-A12YV -[E1], refer to the service manual OB329.
- As for indoor unit MCF-A12WV -[E1], refer to the service manual OB338.



Revision A:

- MU-A12YV -[E1] can be connected to MCF-A12WV -[E1].
SPECIFICATION and PERFORMANCE CURVES have been added.

1 TECHNICAL CHANGES**MU-A07WV-[E1]→MU-A07YV-[E1]****MU-A09WV-[E1]→MU-A09YV-[E1]**

1. Outdoor heat exchanger has changed.
2. Outdoor fan motor has changed. (RA6V23-FC→RC6V20-AC)

MU-A12WV-[E1]→MU-A12YV-[E1]

1. Outdoor heat exchanger has changed.
2. Outdoor fan motor has changed. (RA6V33-DC→ RA6V33-FC)

INFORMATION FOR THE AIR CONDITIONER WITH R410A REFRIGERANT

- This room air conditioner adopts an HFC refrigerant (R410A) which never destroys the ozone layer.
- Pay particular attention to the following points, though the basic installation procedure is same as that for R22 conditioners.
 - ① As R410A has working pressure approximate 1.6 times as high as that of R22, some special tools and piping parts/materials are required. Refer to the table below.
 - ② Take sufficient care not to allow water and other contaminations to enter the R410A refrigerant during storage and installation, since it is more susceptible to contaminations than R22.
 - ③ For refrigerant piping, use clean, pressure-proof parts/materials specifically designed for R410A. (Refer to 2. Refrigerant piping.)
 - ④ Composition change may occur in R410A since it is a mixed refrigerant. When charging, charge liquid refrigerant to prevent composition change.

		New refrigerant	Previous refrigerant
Refrigerant	Refrigerant	R410A	R22
	Composition (Ratio)	HFC-32: HFC-125 (50%:50%)	R22 (100%)
	Refrigerant handling	Pseudo-azeotropic refrigerant	Single refrigerant
	Chlorine	Not included	Included
	Safety group (ASHRAE)	A1/A1	A1
	Molecular weight	72.6	86.5
	Boiling point (°C)	-51.4	-40.8
	Steam pressure [25°C](Mpa)	1.557	0.94
	Saturated steam density [25°C](Kg/m³)	64	44.4
	Combustibility	Non combustible	Non combustible
	ODP *1	0	0.055
	GWP *2	1730	1700
	Refrigerant charge method	From liquid phase in cylinder	Gas phase
	Additional charge on leakage	Possible	Possible
Refrigerating oil	Kind	Incompatible oil	Compatible oil
	Color	Non	Light yellow
	Smell	Non	Non

*1 :Ozone Destruction Parameter : based on CFC-11

*2 :Global Warmth Parameter : based on CO₂



	New Specification	Current Specification
Compressor	<p>The incompatible refrigerating oil easily separates from refrigerant and is in the upper layer inside the suction muffler. Raising position of the oil back hole enables to back the refrigerating oil of the upper layer to flow back to the compressor.</p>	<p>Since refrigerant and refrigerating oil are compatible each, refrigerating oil backs to the compressor through the lower position oil back hole.</p>

NOTE : The unit of pressure has been changed to MPa on the international system of units(SI unit system).
 The conversion factor is: **1(MPa [Gauge]) =10.2(kgf/cm² [Gauge])**

Conversion chart of refrigerant temperature and pressure

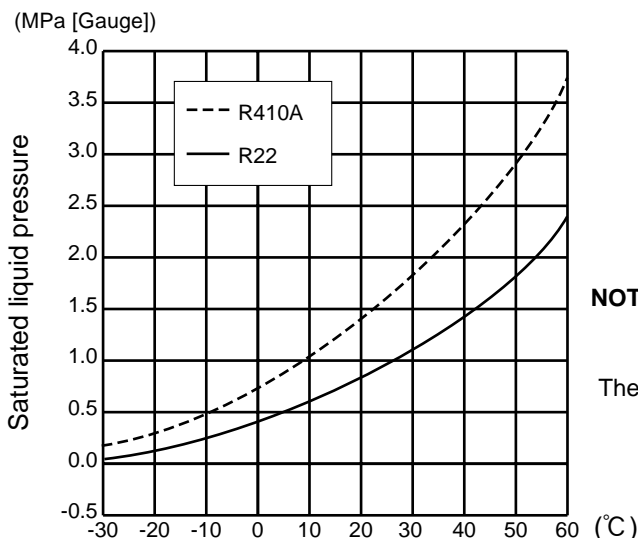

NOTE : The unit of pressure has been changed to MPa on the international system of units(SI unit system).
 The conversion factor is: **1(MPa [Gauge]) =10.2(kgf/cm² [Gauge])**

1.Tools dedicated for the air conditioner with R410A refrigerant

The following tools are required for R410A refrigerant. Some R22 tools can be substituted for R410A tools.
 The diameter of the service port on the stop valve in outdoor unit has been changed to prevent any other refrigerant being charged into the unit. Cap size has been changed from 7/16 UNF with 20 threads to 1/2 UNF with 20 threads.

R410A tools	Can R22 tools be used?	Description
Gauge manifold	No	R410A has high pressures beyond the measurement range of existing gauges. Port diameters have been changed to prevent any other refrigerant from being charged into the unit.
Charge hose	No	Hose material and cap size have been changed to improve the pressure resistance.
Gas leak detector	No	Dedicated for HFC refrigerant.
Torque wrench	Yes	6.35 mm and 9.52 mm
	No	12.7 mm
Flare tool	Yes	Clamp bar hole has been enlarged to reinforce the spring strength in the tool.
Flare gauge	New	Provided for flaring work (to be used with R22 flare tool).
Vacuum pump adapter	New	Provided to prevent the back flow of oil. This adapter enables you to use vacuum pumps.
Electronic scale for refrigerant charging	New	It is difficult to measure R410A with a charging cylinder because the refrigerant bubbles due to high pressure and high-speed vaporization

No : Not Substitutable for R410A Yes : Substitutable for R410A

2.Refrigerant piping

① Specifications

Use the refrigerant pipes that meet the following specifications.

Pipe	Outside diameter	Wall thickness	Insulation material
	mm		
For liquid	6.35	0.8 mm	Heat resisting foam plastic Specific gravity 0.045 Thickness 8 mm
For gas	9.52	0.8 mm	
	12.7	0.8 mm	

- Use a copper pipe or a copper-alloy seamless pipe with a thickness of 0.8 mm. Never use any pipe with a thickness less than 0.8mm, as the pressure resistance is insufficient.

② Flaring work and flare nut

Flaring work for R410A pipe differs from that for R22 pipe.

For details of flaring work, refer to Installation manual "FLARING WORK".

Pipe diameter	Dimension of flare nut	
	R410A	R22
mm		
6.35	17	17
9.52	22	22
12.7	26	24

3.Refrigerant oil

Apply the special refrigeration oil (accessories: packed with indoor unit) to the flare and the union seat surfaces.

4.Air purge

- Do not discharge the refrigerant into the atmosphere.
Take care not to discharge refrigerant into the atmosphere during installation, reinstallation, or repairs to the refrigerant circuit.
- Use the vacuum pump for air purging for the purpose of environmental protection.

5.Additional charge

For additional charging, charge the refrigerant from liquid phase of the gas cylinder.

If the refrigerant is charged from the gas phase, composition change may occur in the refrigerant inside the cylinder and the outdoor unit. In this case, ability of the refrigerating cycle decreases or normal operation can be impossible. However, charging the liquid refrigerant all at once may cause the compressor to be locked. Thus, charge the refrigerant slowly.

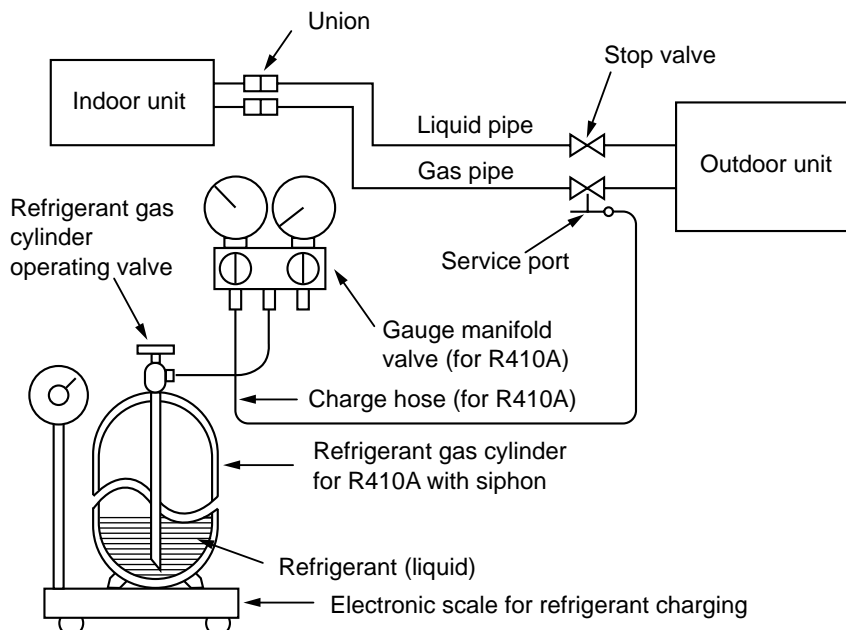

2

PART NAMES AND FUNCTIONS

OUTDOOR UNIT

MU-A07YV - [E1]

MU-A09YV - [E1]

MU-A12YV - [E1]

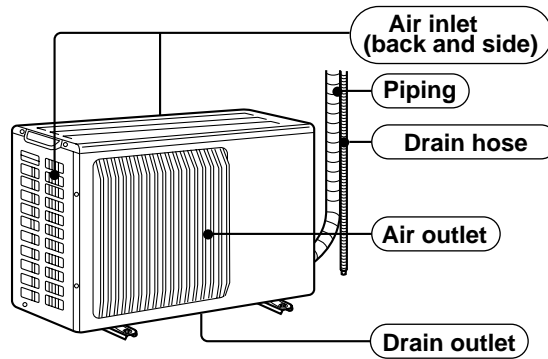

3

SPECIFICATION

Outdoor model			MU-A07YV - [E1]	MU-A09YV - [E1]	MU-A12YV - [E1] Indoor unit MSC-A12YV - [E1]	MU-A12YV - [E1] Indoor unit MCF-A12WV - [E1]
Outdoor unit power supply			Single phase 230V,50Hz	Single phase 230V,50Hz	Single phase 230V,50Hz	Single phase 230V,50Hz
Capacity	Capacity	kW	2.3	2.55	3.5	3.5
	Dehumidification	ℓ/h	0.9	1.1	1.7	1.5
	Outdoor air flow	m³/h	1,686	1,686	1,914	1,914
Electrical data	Power outlet	A	10	10	10	10
	Running current	A	3.00	3.32	4.92	4.89
	Power input	W	680	760	1,100	1,104
	Auxiliary heater	A(kW)	—	—	—	—
	Power factor	%	98	99	97	98
	Starting current	A	23	24	29	29
	Compressor motor current	A	2.78	3.10	4.61	4.58
	Fan motor current	A	0.22	0.22	0.31	0.31
Coefficient of performance(C.O.P)			3.22	3.21	3.07	3.02
Compressor	Model		RN092VHSHT	RN099VHSHT	RN135VHSHT	RN135VHSHT
	Output	W	600	700	900	900
	Winding resistance(at 20°C)	Ω	C-R 3.87 C-S 6.14	C-R 3.40 C-S 4.56	C-R 2.79 C-S 3.36	C-R 2.79 C-S 3.36
Fan motor	Model		RC6V20-AC	RC6V20-AC	RA6V33-FC	RA6V33-FC
	Winding resistance(at 20°C)	Ω	WHT-BLK 410 BLK-RED 433	WHT-BLK 410 BLK-RED 433	WHT-BLK 223 BLK-RED 228	WHT-BLK 223 BLK-RED 228
Dimensions W×H×D			mm	780×540×255	780×540×255	780×540×255
Weight			kg	34	36	36
Special remarks	Sound level	dB	45	45	49	49
	Fan speed	rpm	735	735	825	825
	Fan speed regulator		1	1	1	1
	Refrigerant filling capacity (R410A)	kg	0.60	0.60	0.75	0.75
	Refrigerating oil (Model)	cc	350 (NEO22)	350 (NEO22)	620 (NEO22)	620 (NEO22)

NOTE: Test conditions are based on ISO 5151.

Cooling : Indoor DB27°C WB19°C

Outdoor DB35°C WB24°C

Indoor-Outdoor piping length : 5m

NOISE CRITERIA CURVES

MU-A07YV- E1
 MU-A09YV- E1

FUNCTION	SPL(dB(A))	LINE
COOL	45	

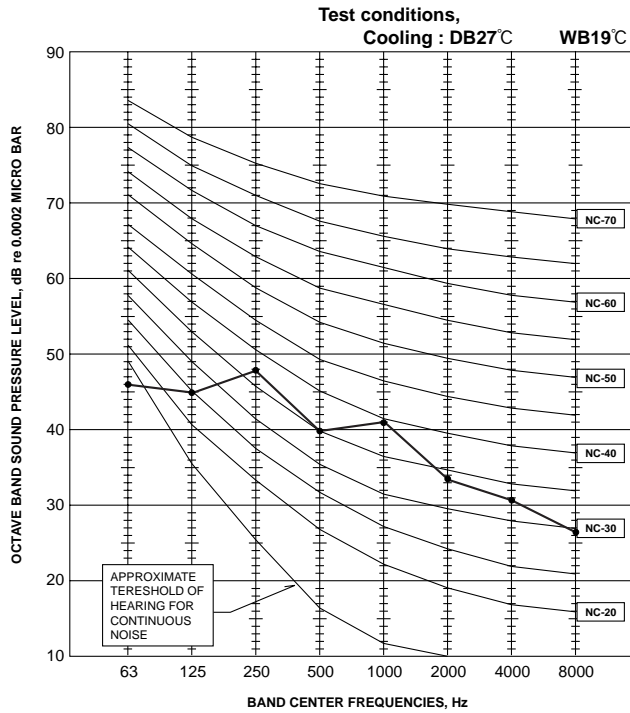

MU-A12YV- E1

FUNCTION	SPL(dB(A))	LINE
COOL	49	

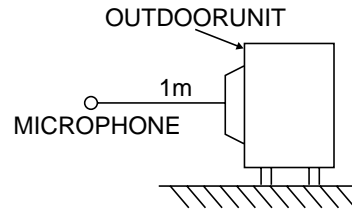
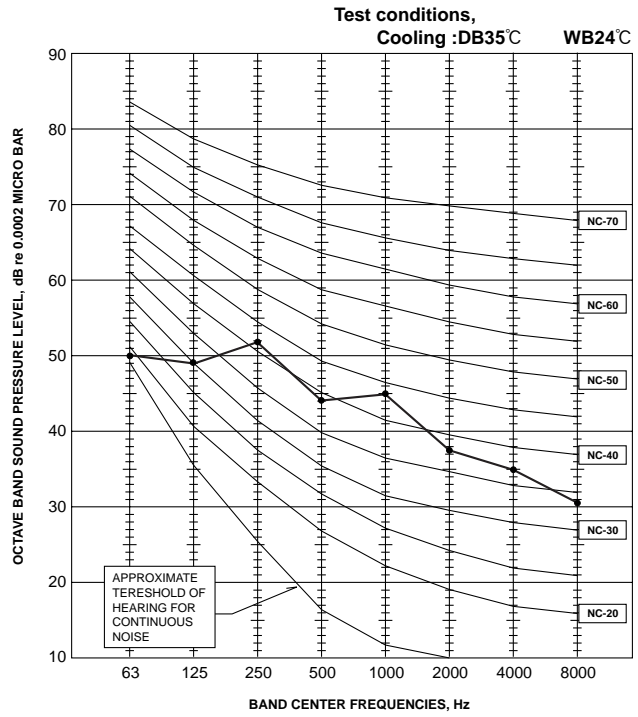

5

OUTLINES AND DIMENSIONS

MU-A07YV -E1 MU-A09YV -E1 MU-A12YV -E1

OUTDOOR UNIT

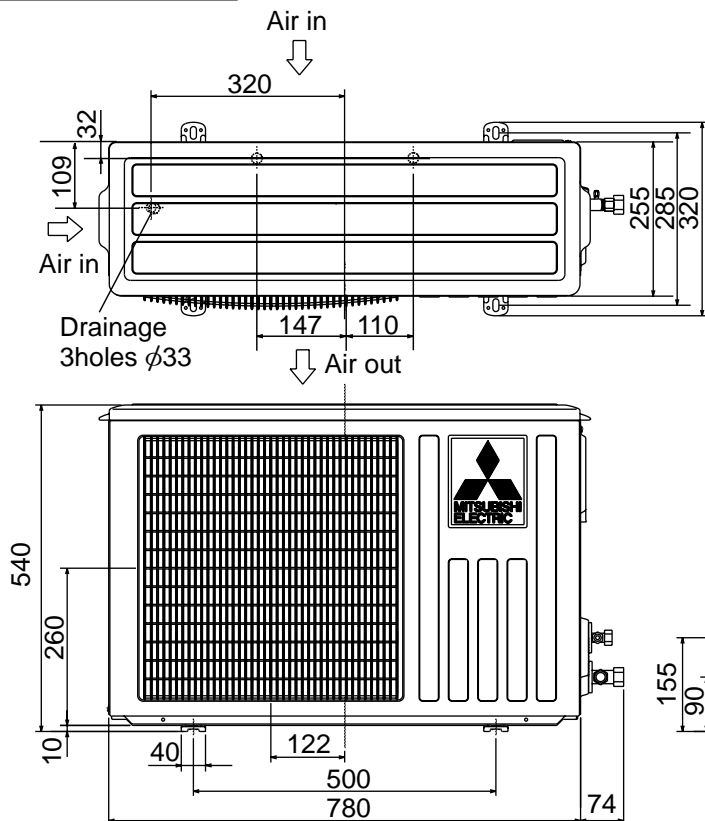

REQUIRED SPACE

Unit: mm

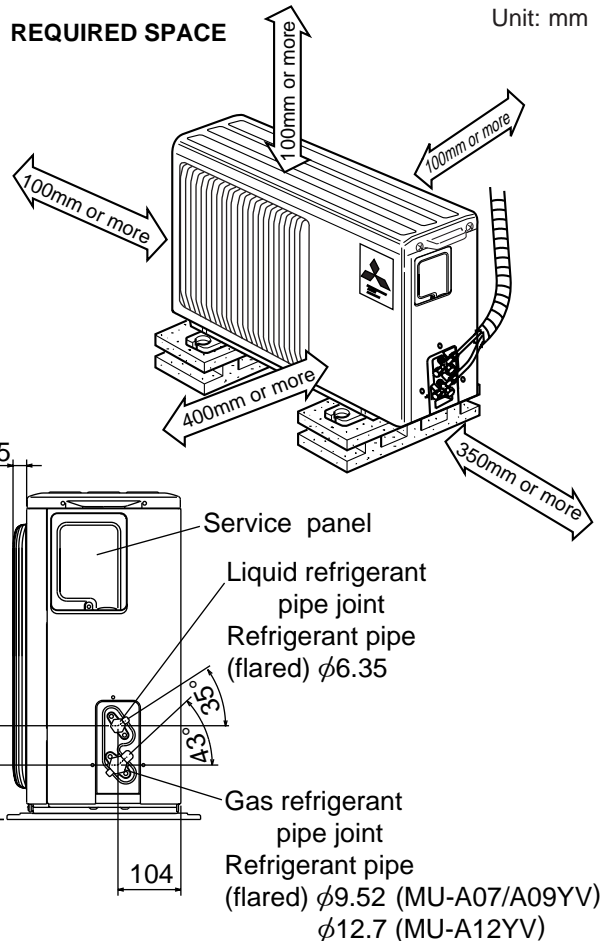

6

WIRING DIAGRAM

MU-A07YV -E1 MU-A09YV -E1 MU-A12YV -E1

OUTDOOR UNIT

MODELS WIRING DIAGRAM

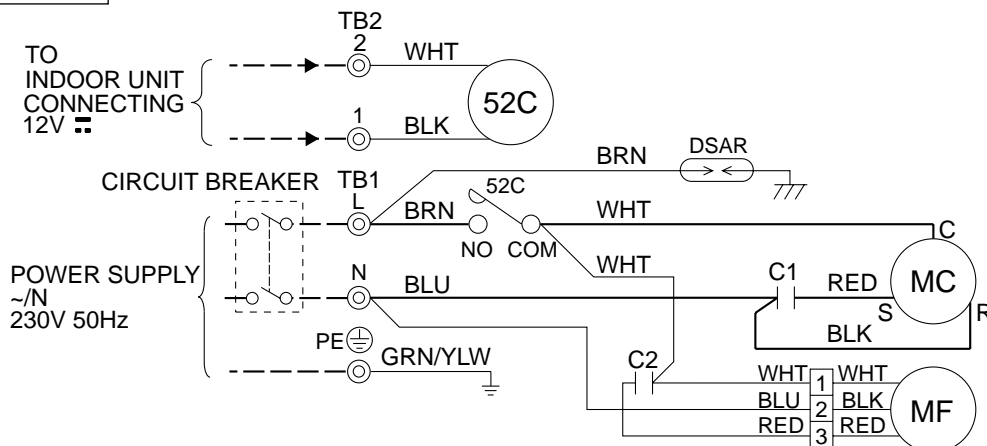

SYMBOL	NAME	SYMBOL	NAME	SYMBOL	NAME
C1	COMPRESSOR CAPACITOR	MC	COMPRESSOR(INNER PROTECTOR)	TB1, TB2	TERMINAL BLOCK
C2	OUTDOOR FAN CAPACITOR	MF	OUTDOOR FAN MOTOR (INNER FUSE/INNER PROTECTOR)	52C	COMPRESSOR CONTACTOR
DSAR	SURGE ABSORBER				

NOTE:1. About the indoor side electric wiring refer to the indoor unit electric wiring diagram for servicing.

2. Use copper conductors only. (For field wiring)

3. Symbols below indicate.

⊙: Terminal block, □□□□: Connector

REFRIGERANT SYSTEM DIAGRAM

MU-A07YV -E1

Unit:mm

MU-A09YV -E1

OUTDOOR UNIT

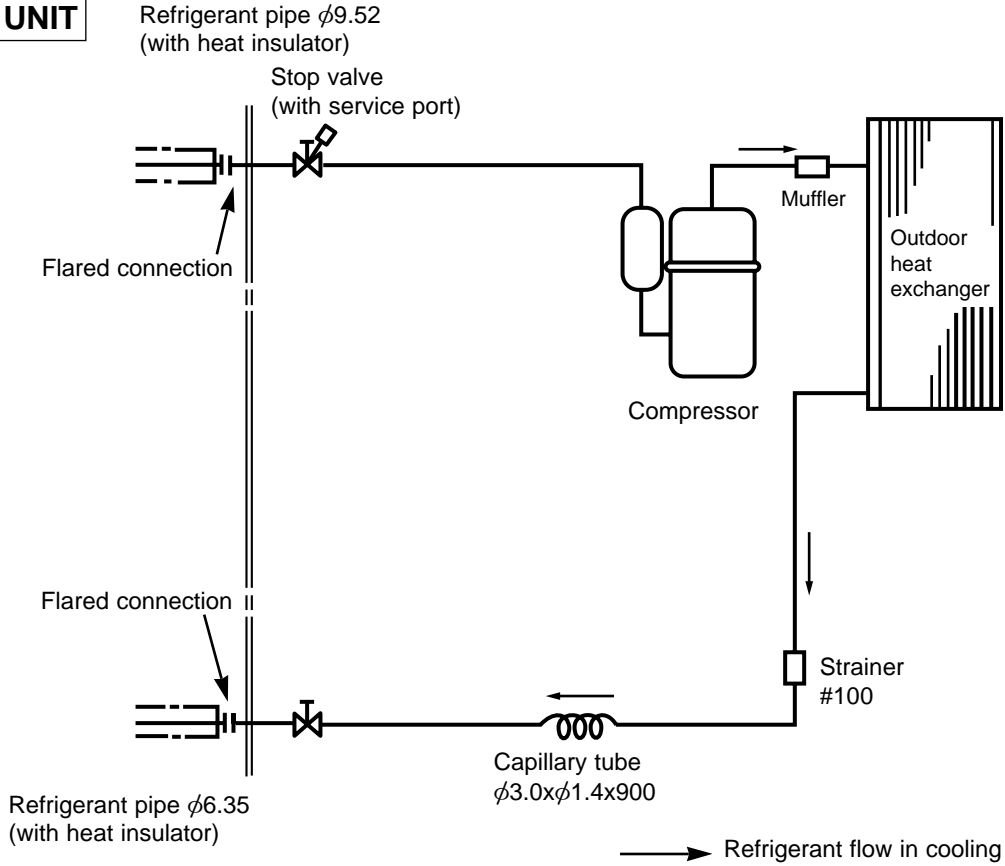

MU-A12YV -E1

Unit:mm

OUTDOOR UNIT

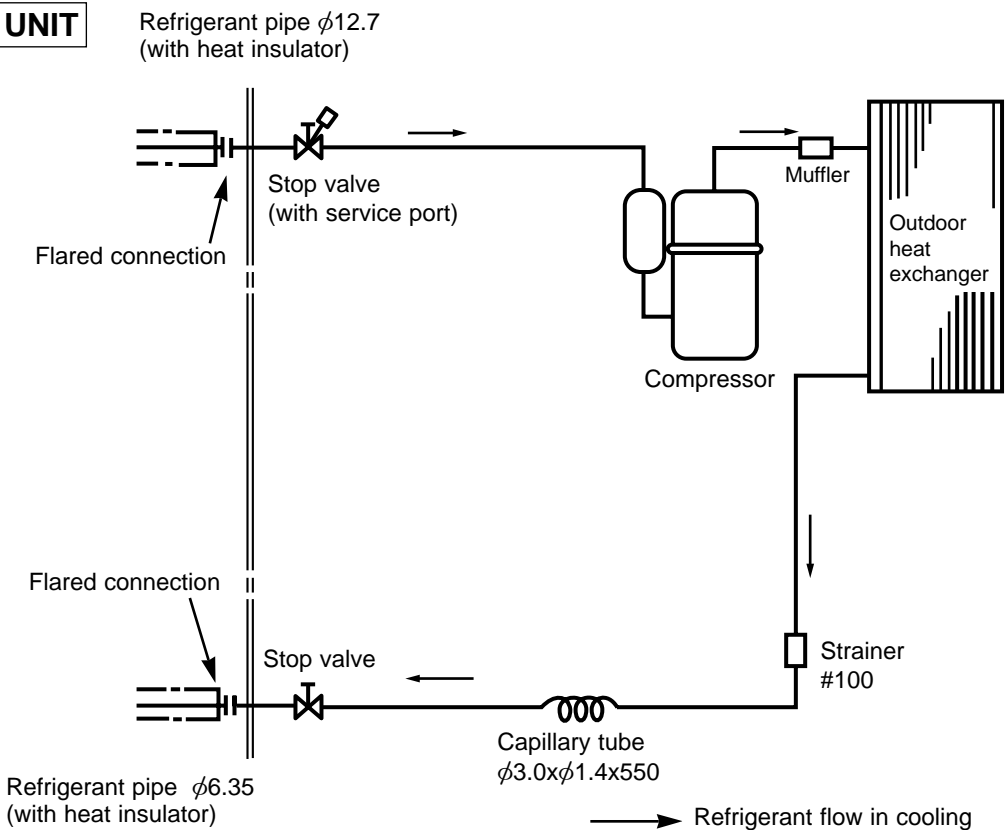

MAX. REFRIGERANT PIPING LENGTH

Model	Refrigerant piping Max. length : m	Piping size O.D : mm		Length of connecting pipe : m	
		Gas	Liquid	Indoor unit	Outdoor unit
MU-A07YV - E1	20	9.52	6.35	Gas 0.43 Liquid 0.5	Gas 0 Liquid 0
MU-A09YV - E1					
MU-A12YV - E1	25	12.7			

MAX. HEIGHT DIFFERENCE

Height difference should be within 10m regardless of which unit, indoor or outdoor position is high.

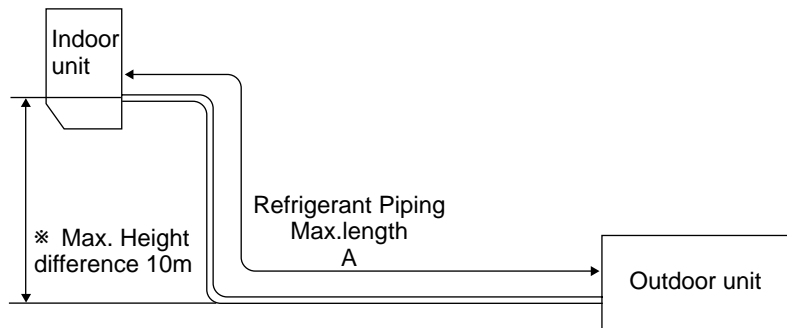

ADDITIONAL REFRIGERANT CHARGE(R410A : g)

Model	Outdoor unit precharged	Refrigerant piping length (one way)				
		7m	10m	15m	20m	25m
MU-A07YV - E1	600	0	60	160	260	/
MU-A09YV - E1						
MU-A12YV - E1	750					360

Calculation : $X_g = 20g/m \times (A - 7)m$

8

PERFORMANCE CURVES

MU-A07YV - E1 MU-A09YV - E1 MU-A12YV - E1

The standard data contained in these specifications apply only to the operation of the air conditioner under normal conditions, since operating conditions vary according to the areas where these units are installed. The following information has been provided to clarify the operating characteristics of the air conditioner under the conditions indicated by the performance curve.

(1) GUARANTEED VOLTAGE

198~264V

(2) AIR FLOW

Air flow should be set at MAX.

(3) MAIN READINGS

- | | | | |
|---|------|---|---------|
| (1) Indoor intake air wet-bulb temperature : | °CWB | } | Cooling |
| (2) Indoor outlet air wet-bulb temperature : | °CWB | | |
| (3) Outdoor intake air dry-bulb temperature : | °CDB | | |
| (4) Total input: | W | | |

Indoor air wet/dry-bulb temperature difference on the left side of the chart on next page shows the difference between the indoor intake air wet/dry-bulb temperature and the indoor outlet air wet/dry-bulb temperature for your reference at service.

How to measure the indoor air wet-bulb/dry-bulb temperature difference

- Attach at least 2 sets of wet-and dry-bulb thermometers to the indoor air intake as shown in the figure, and at least 2 sets of wet-and dry-bulb thermometers to the indoor air outlet. The thermometers must be attached to the position where air speed is high.
- Attach at least 2 sets of wet-and dry-bulb thermometers to the outdoor air intake.
Cover the thermometers to prevent direct rays of the sun.
- Check that the air filter is cleaned.
- Open windows and doors of room.
- Press the EMERGENCY OPERATION switch once to start the EMERGENCY COOL MODE.
- When system stabilizes after more than 15 minutes, measure temperature and take an average temperature.
- 10 minutes later, measure temperature again and check that the temperature does not change.

INDOOR UNIT

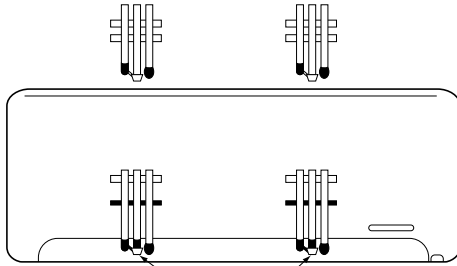

Wet-and dry-bulb
thermometers

FRONT VIEW

OUTDOOR UNIT

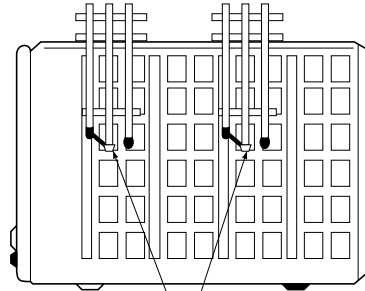

Wet-and dry-bulb
thermometers

BACK VIEW

8-1.CAPACITY AND THE INPUT CURVES

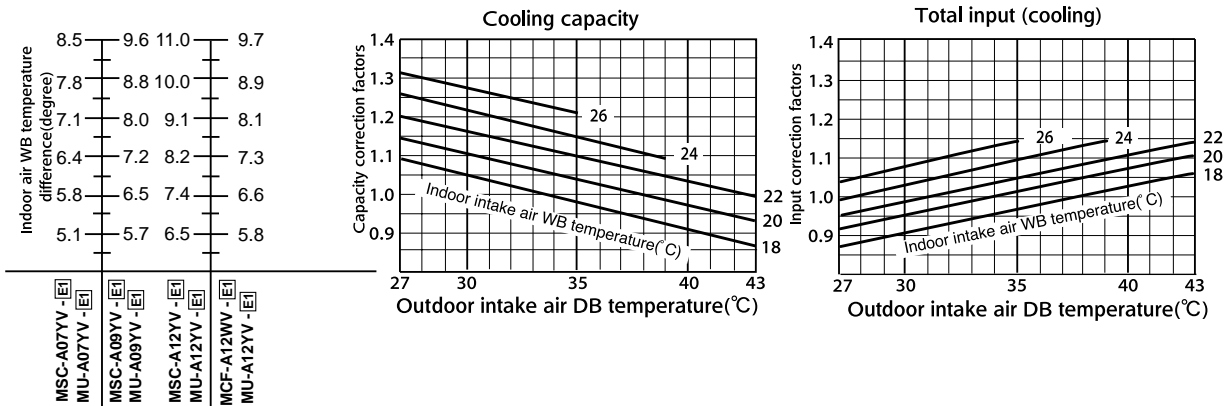

8-2.OUTDOOR LOW PRESSURE AND OUTDOOR UNIT CURRENT COOL operation

① Both indoor and outdoor unit are under the same temperature/humidity condition.

Dry-bulb temperature	Relative humidity(%)
20	50
25	60
30	70

② Air flow should be set at MAX.

③ The unit of pressure has been changed to MPa on the international system of units(SI unit system).

The conversion factor is : **1(MPa[Gauge]) =10.2(kgf/cm²[Gauge])**

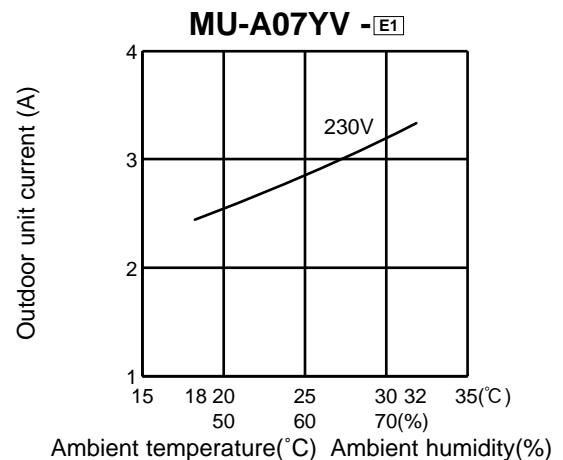
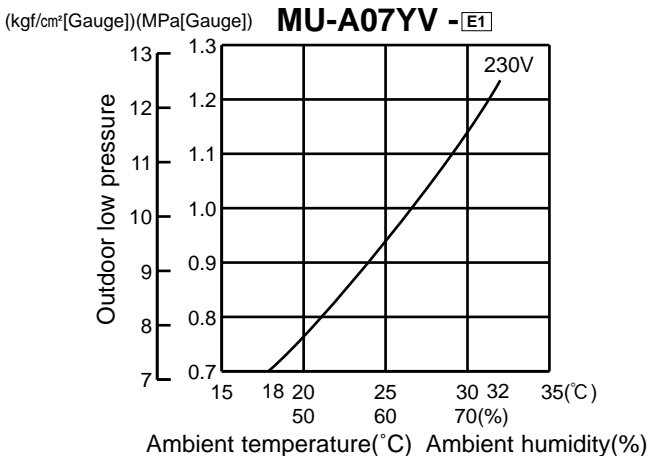

(kgf/cm²[Gauge])(MPa[Gauge]) **MU-A09YV -E1**

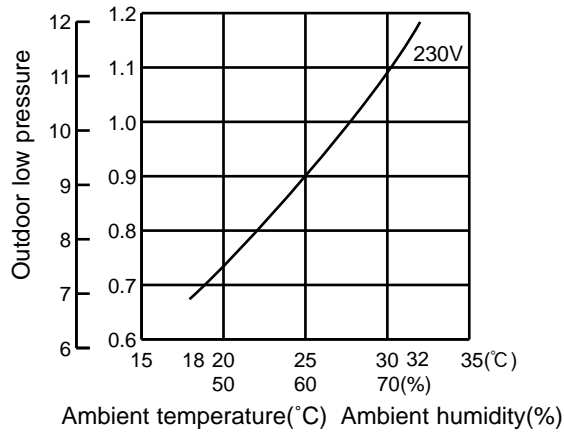

MU-A09YV -E1

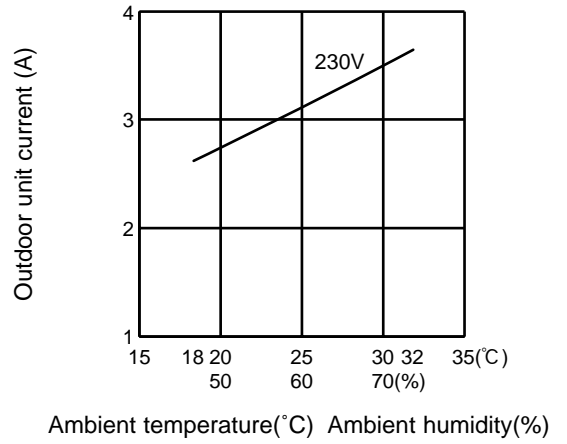

MU-A12YV -E1

(kgf/cm²[Gauge])(MPa[Gauge]) **(Indoor unit : MSC-A12YV -E1)**

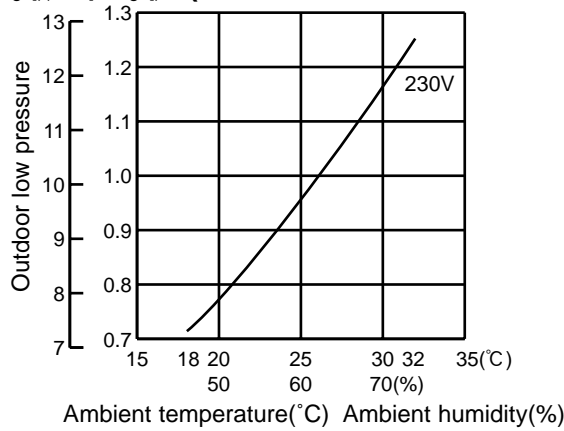

MU-A12YV -E1

(Indoor unit : MSC-A12YV -E1)

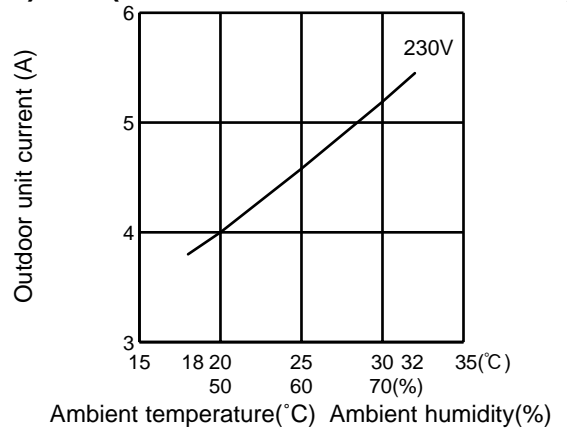

MU-A12YV -E1

(kgf/cm²[Gauge])(MPa[Gauge]) **(Indoor unit : MCF-A12WV -E1)**

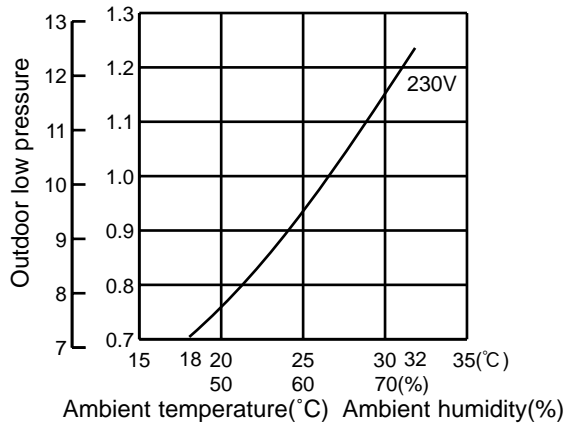

MU-A12YV -E1

(Indoor unit : MCF-A12WV -E1)

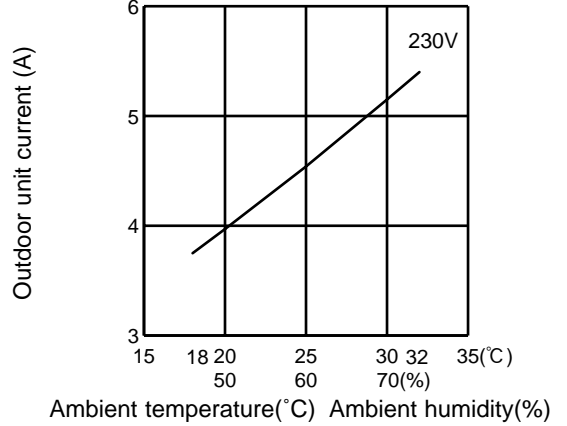

PERFORMANCE DATA
COOL operation (230V)

MSC-A07YV -[E1] : MU-A07YV -[E1]

CAPACITY : 2.3(KW) SHF : 0.74 INPUT : 715(W)

		OUTDOOR DB(°C)															
INDOOR DB(°C)	INDOOR WB(°C)	21				25				27				30			
		Q	SHC	SHF	INPUT	Q	SHC	SHF	INPUT	Q	SHC	SHF	INPUT	Q	SHC	SHF	INPUT
21	18	2.70	1.51	0.56	572	2.59	1.45	0.56	601	2.48	1.39	0.56	629	2.39	1.34	0.56	658
21	20	2.82	1.24	0.44	601	2.70	1.19	0.44	636	2.62	1.15	0.44	651	2.53	1.11	0.44	679
22	18	2.70	1.62	0.60	572	2.59	1.55	0.60	601	2.48	1.49	0.60	629	2.39	1.44	0.60	658
22	20	2.82	1.35	0.48	601	2.70	1.30	0.48	636	2.62	1.26	0.48	651	2.53	1.21	0.48	679
22	22	2.93	1.06	0.36	622	2.83	1.02	0.36	661	2.76	0.99	0.36	679	2.65	0.95	0.36	708
23	18	2.70	1.73	0.64	572	2.59	1.66	0.64	601	2.48	1.59	0.64	629	2.39	1.53	0.64	658
23	20	2.82	1.47	0.52	601	2.70	1.41	0.52	636	2.62	1.36	0.52	651	2.53	1.32	0.52	679
23	22	2.93	1.17	0.40	622	2.83	1.13	0.40	661	2.76	1.10	0.40	679	2.65	1.06	0.40	708
24	18	2.70	1.84	0.68	572	2.59	1.76	0.68	601	2.48	1.69	0.68	629	2.39	1.63	0.68	658
24	20	2.82	1.58	0.56	601	2.70	1.51	0.56	636	2.62	1.47	0.56	651	2.53	1.42	0.56	679
24	22	2.93	1.29	0.44	622	2.83	1.24	0.44	661	2.76	1.21	0.44	679	2.65	1.16	0.44	708
24	24	3.08	0.99	0.32	651	2.97	0.95	0.32	686	2.90	0.93	0.32	708	2.81	0.90	0.32	744
25	18	2.70	1.95	0.72	572	2.59	1.86	0.72	601	2.48	1.79	0.72	629	2.39	1.72	0.72	658
25	20	2.82	1.69	0.60	601	2.70	1.62	0.60	636	2.62	1.57	0.60	651	2.53	1.52	0.60	679
25	22	2.93	1.41	0.48	622	2.83	1.36	0.48	661	2.76	1.32	0.48	679	2.65	1.27	0.48	708
25	24	3.08	1.11	0.36	651	2.97	1.07	0.36	686	2.90	1.04	0.36	708	2.81	1.01	0.36	744
26	18	2.70	2.05	0.76	572	2.59	1.97	0.76	601	2.48	1.89	0.76	629	2.39	1.82	0.76	658
26	20	2.82	1.80	0.64	601	2.70	1.73	0.64	636	2.62	1.68	0.64	651	2.53	1.62	0.64	679
26	22	2.93	1.52	0.52	622	2.83	1.47	0.52	661	2.76	1.44	0.52	679	2.65	1.38	0.52	708
26	24	3.08	1.23	0.40	651	2.97	1.19	0.40	686	2.90	1.16	0.40	708	2.81	1.12	0.40	744
26	26	3.17	0.89	0.28	686	3.08	0.86	0.28	722	3.04	0.85	0.28	744	2.94	0.82	0.28	765
27	18	2.70	2.16	0.80	572	2.59	2.07	0.80	601	2.48	1.99	0.80	629	2.39	1.91	0.80	658
27	20	2.82	1.92	0.68	601	2.70	1.84	0.68	636	2.62	1.78	0.68	651	2.53	1.72	0.68	679
27	22	2.93	1.64	0.56	622	2.83	1.58	0.56	661	2.76	1.55	0.56	679	2.65	1.48	0.56	708
27	24	3.08	1.36	0.44	651	2.97	1.31	0.44	686	2.90	1.28	0.44	708	2.81	1.23	0.44	744
27	26	3.17	1.02	0.32	686	3.08	0.99	0.32	722	3.04	0.97	0.32	744	2.94	0.94	0.32	765
28	18	2.70	2.27	0.84	572	2.59	2.17	0.84	601	2.48	2.09	0.84	629	2.39	2.01	0.84	658
28	20	2.82	2.03	0.72	601	2.70	1.95	0.72	636	2.62	1.89	0.72	651	2.53	1.82	0.72	679
28	22	2.93	1.76	0.60	622	2.83	1.70	0.60	661	2.76	1.66	0.60	679	2.65	1.59	0.60	708
28	24	3.08	1.48	0.48	651	2.97	1.42	0.48	686	2.90	1.39	0.48	708	2.81	1.35	0.48	744
28	26	3.17	1.14	0.36	686	3.08	1.11	0.36	722	3.04	1.09	0.36	744	2.94	1.06	0.36	765
29	18	2.70	2.38	0.88	572	2.59	2.28	0.88	601	2.48	2.19	0.88	629	2.39	2.10	0.88	658
29	20	2.82	2.14	0.76	601	2.70	2.05	0.76	636	2.62	1.99	0.76	651	2.53	1.92	0.76	679
29	22	2.93	1.88	0.64	622	2.83	1.81	0.64	661	2.76	1.77	0.64	679	2.65	1.69	0.64	708
29	24	3.08	1.60	0.52	651	2.97	1.54	0.52	686	2.90	1.51	0.52	708	2.81	1.46	0.52	744
29	26	3.17	1.27	0.40	686	3.08	1.23	0.40	722	3.04	1.21	0.40	744	2.94	1.18	0.40	765
30	18	2.70	2.49	0.92	572	2.59	2.38	0.92	601	2.48	2.29	0.92	629	2.39	2.20	0.92	658
30	20	2.82	2.25	0.80	601	2.70	2.16	0.80	636	2.62	2.10	0.80	651	2.53	2.02	0.80	679
30	22	2.93	1.99	0.68	622	2.83	1.92	0.68	661	2.76	1.88	0.68	679	2.65	1.80	0.68	708
30	24	3.08	1.73	0.56	651	2.97	1.66	0.56	686	2.90	1.62	0.56	708	2.81	1.57	0.56	744
30	26	3.17	1.40	0.44	686	3.08	1.36	0.44	722	3.04	1.34	0.44	744	2.94	1.30	0.44	765
31	18	2.70	2.59	0.96	572	2.59	2.48	0.96	601	2.48	2.38	0.96	629	2.39	2.30	0.96	658
31	20	2.82	2.37	0.84	601	2.70	2.27	0.84	636	2.62	2.20	0.84	651	2.53	2.13	0.84	679
31	22	2.93	2.11	0.72	622	2.83	2.04	0.72	661	2.76	1.99	0.72	679	2.65	1.90	0.72	708
31	24	3.08	1.85	0.60	651	2.97	1.78	0.60	686	2.90	1.74	0.60	708	2.81	1.68	0.60	744
31	26	3.17	1.52	0.48	686	3.08	1.48	0.48	722	3.04	1.46	0.48	744	2.94	1.41	0.48	765
32	18	2.70	2.70	1.00	572	2.59	2.59	1.00	601	2.48	2.48	1.00	629	2.39	2.39	1.00	658
32	20	2.82	2.48	0.88	601	2.70	2.38	0.88	636	2.62	2.31	0.88	651	2.53	2.23	0.88	679
32	22	2.93	2.23	0.76	622	2.83	2.15	0.76	661	2.76	2.10	0.76	679	2.65	2.01	0.76	708
32	24	3.08	1.97	0.64	651	2.97	1.90	0.64	686	2.90	1.85	0.64	708	2.81	1.80	0.64	744
32	26	3.17	1.65	0.52	686	3.08	1.60	0.52	722	3.04	1.58	0.52	744	2.94	1.53	0.52	765

NOTE Q :Total capacity (kW) SHF :Sensible heat factor DB :Dry-bulb temperature
SHC :Sensible heat capacity (kW) INPUT :Total power input (W) WB :Wet-bulb temperature

PERFORMANCE DATA

COOL operation (230V)

MSC-A07YV -[E1] : MU-A07YV -[E1]

CAPACITY : 2.3(KW) SHF : 0.74 INPUT : 715(W)

		OUTDOOR DB(°C)											
INDOOR DB(°C)	INDOOR WB(°C)	35				40				43			
		Q	SHC	SHF	INPUT	Q	SHC	SHF	INPUT	Q	SHC	SHF	INPUT
21	18	2.25	1.26	0.56	701	2.07	1.16	0.56	744	1.99	1.11	0.56	758
21	20	2.37	1.04	0.44	729	2.21	0.97	0.44	765	2.13	0.94	0.44	787
22	18	2.25	1.35	0.60	701	2.07	1.24	0.60	744	1.99	1.19	0.60	758
22	20	2.37	1.14	0.48	729	2.21	1.06	0.48	765	2.13	1.02	0.48	787
22	22	2.51	0.90	0.36	758	2.35	0.84	0.36	801	2.27	0.82	0.36	815
23	18	2.25	1.44	0.64	701	2.07	1.32	0.64	744	1.99	1.27	0.64	758
23	20	2.37	1.23	0.52	729	2.21	1.15	0.52	765	2.13	1.11	0.52	787
23	22	2.51	1.00	0.40	758	2.35	0.94	0.40	801	2.27	0.91	0.40	815
24	18	2.25	1.53	0.68	701	2.07	1.41	0.68	744	1.99	1.35	0.68	758
24	20	2.37	1.33	0.56	729	2.21	1.24	0.56	765	2.13	1.19	0.56	787
24	22	2.51	1.10	0.44	758	2.35	1.03	0.44	801	2.27	1.00	0.44	815
24	24	2.65	0.85	0.32	787	2.48	0.79	0.32	822	2.42	0.77	0.32	840
25	18	2.25	1.62	0.72	701	2.07	1.49	0.72	744	1.99	1.43	0.72	758
25	20	2.37	1.42	0.60	729	2.21	1.32	0.60	765	2.13	1.28	0.60	787
25	22	2.51	1.20	0.48	758	2.35	1.13	0.48	801	2.27	1.09	0.48	815
25	24	2.65	0.95	0.36	787	2.48	0.89	0.36	822	2.42	0.87	0.36	840
26	18	2.25	1.71	0.76	701	2.07	1.57	0.76	744	1.99	1.51	0.76	758
26	20	2.37	1.52	0.64	729	2.21	1.41	0.64	765	2.13	1.36	0.64	787
26	22	2.51	1.30	0.52	758	2.35	1.22	0.52	801	2.27	1.18	0.52	815
26	24	2.65	1.06	0.40	787	2.48	0.99	0.40	822	2.42	0.97	0.40	840
26	26	2.78	0.78	0.28	815	2.62	0.73	0.28	851	2.54	0.71	0.28	869
27	18	2.25	1.80	0.80	701	2.07	1.66	0.80	744	1.99	1.59	0.80	758
27	20	2.37	1.61	0.68	729	2.21	1.50	0.68	765	2.13	1.45	0.68	787
27	22	2.51	1.40	0.56	758	2.35	1.31	0.56	801	2.27	1.27	0.56	815
27	24	2.65	1.16	0.44	787	2.48	1.09	0.44	822	2.42	1.06	0.44	840
27	26	2.78	0.89	0.32	815	2.62	0.84	0.32	851	2.54	0.81	0.32	869
28	18	2.25	1.89	0.84	701	2.07	1.74	0.84	744	1.99	1.67	0.84	758
28	20	2.37	1.71	0.72	729	2.21	1.59	0.72	765	2.13	1.53	0.72	787
28	22	2.51	1.50	0.60	758	2.35	1.41	0.60	801	2.27	1.36	0.60	815
28	24	2.65	1.27	0.48	787	2.48	1.19	0.48	822	2.42	1.16	0.48	840
28	26	2.78	1.00	0.36	815	2.62	0.94	0.36	851	2.54	0.91	0.36	869
29	18	2.25	1.98	0.88	701	2.07	1.82	0.88	744	1.99	1.75	0.88	758
29	20	2.37	1.80	0.76	729	2.21	1.68	0.76	765	2.13	1.62	0.76	787
29	22	2.51	1.60	0.64	758	2.35	1.50	0.64	801	2.27	1.45	0.64	815
29	24	2.65	1.38	0.52	787	2.48	1.29	0.52	822	2.42	1.26	0.52	840
29	26	2.78	1.11	0.40	815	2.62	1.05	0.40	851	2.54	1.02	0.40	869
30	18	2.25	2.07	0.92	701	2.07	1.90	0.92	744	1.99	1.83	0.92	758
30	20	2.37	1.90	0.80	729	2.21	1.77	0.80	765	2.13	1.70	0.80	787
30	22	2.51	1.70	0.68	758	2.35	1.60	0.68	801	2.27	1.54	0.68	815
30	24	2.65	1.48	0.56	787	2.48	1.39	0.56	822	2.42	1.35	0.56	840
30	26	2.78	1.22	0.44	815	2.62	1.15	0.44	851	2.54	1.12	0.44	869
31	18	2.25	2.16	0.96	701	2.07	1.99	0.96	744	1.99	1.91	0.96	758
31	20	2.37	1.99	0.84	729	2.21	1.85	0.84	765	2.13	1.79	0.84	787
31	22	2.51	1.81	0.72	758	2.35	1.69	0.72	801	2.27	1.63	0.72	815
31	24	2.65	1.59	0.60	787	2.48	1.49	0.60	822	2.42	1.45	0.60	840
31	26	2.78	1.34	0.48	815	2.62	1.26	0.48	851	2.54	1.22	0.48	869
32	18	2.25	2.25	1.00	701	2.07	2.07	1.00	744	1.99	1.99	1.00	758
32	20	2.37	2.08	0.88	729	2.21	1.94	0.88	765	2.13	1.87	0.88	787
32	22	2.51	1.91	0.76	758	2.35	1.78	0.76	801	2.27	1.72	0.76	815
32	24	2.65	1.69	0.64	787	2.48	1.59	0.64	822	2.42	1.55	0.64	840
32	26	2.78	1.45	0.52	815	2.62	1.36	0.52	851	2.54	1.32	0.52	869

NOTE Q :Total capacity (kW) SHF :Sensible heat factor DB :Dry-bulb temperature
 SHC :Sensible heat capacity (kW) INPUT :Total power input (W) WB :Wet-bulb temperature

PERFORMANCE DATA
COOL operation (230V)

MSC-A09YV -[E1] : MU-A09YV -[E1]

CAPACITY : 2.55(KW) SHF : 0.70 INPUT : 795(W)

		OUTDOOR DB(°C)															
INDOOR DB(°C)	INDOOR WB(°C)	21				25				27				30			
		Q	SHC	SHF	INPUT	Q	SHC	SHF	INPUT	Q	SHC	SHF	INPUT	Q	SHC	SHF	INPUT
21	18	3.00	1.56	0.52	636	2.87	1.49	0.52	668	2.75	1.43	0.52	700	2.65	1.38	0.52	731
21	20	3.12	1.25	0.40	668	3.00	1.20	0.40	708	2.91	1.16	0.40	723	2.81	1.12	0.40	755
22	18	3.00	1.68	0.56	636	2.87	1.61	0.56	668	2.75	1.54	0.56	700	2.65	1.49	0.56	731
22	20	3.12	1.37	0.44	668	3.00	1.32	0.44	708	2.91	1.28	0.44	723	2.81	1.23	0.44	755
22	22	3.25	1.04	0.32	692	3.14	1.00	0.32	735	3.06	0.98	0.32	755	2.93	0.94	0.32	787
23	18	3.00	1.80	0.60	636	2.87	1.72	0.60	668	2.75	1.65	0.60	700	2.65	1.59	0.60	731
23	20	3.12	1.50	0.48	668	3.00	1.44	0.48	708	2.91	1.40	0.48	723	2.81	1.35	0.48	755
23	22	3.25	1.17	0.36	692	3.14	1.13	0.36	735	3.06	1.10	0.36	755	2.93	1.06	0.36	787
24	18	3.00	1.92	0.64	636	2.87	1.84	0.64	668	2.75	1.76	0.64	700	2.65	1.70	0.64	731
24	20	3.12	1.62	0.52	668	3.00	1.56	0.52	708	2.91	1.51	0.52	723	2.81	1.46	0.52	755
24	22	3.25	1.30	0.40	692	3.14	1.25	0.40	735	3.06	1.22	0.40	755	2.93	1.17	0.40	787
24	24	3.42	0.96	0.28	723	3.29	0.92	0.28	763	3.21	0.90	0.28	787	3.11	0.87	0.28	827
25	18	3.00	2.04	0.68	636	2.87	1.95	0.68	668	2.75	1.87	0.68	700	2.65	1.80	0.68	731
25	20	3.12	1.75	0.56	668	3.00	1.68	0.56	708	2.91	1.63	0.56	723	2.81	1.57	0.56	755
25	22	3.25	1.43	0.44	692	3.14	1.38	0.44	735	3.06	1.35	0.44	755	2.93	1.29	0.44	787
25	24	3.42	1.09	0.32	723	3.29	1.05	0.32	763	3.21	1.03	0.32	787	3.11	1.00	0.32	827
26	18	3.00	2.16	0.72	636	2.87	2.07	0.72	668	2.75	1.98	0.72	700	2.65	1.91	0.72	731
26	20	3.12	1.87	0.60	668	3.00	1.80	0.60	708	2.91	1.74	0.60	723	2.81	1.68	0.60	755
26	22	3.25	1.56	0.48	692	3.14	1.51	0.48	735	3.06	1.47	0.48	755	2.93	1.41	0.48	787
26	24	3.42	1.23	0.36	723	3.29	1.18	0.36	763	3.21	1.16	0.36	787	3.11	1.12	0.36	827
26	26	3.52	0.84	0.24	763	3.42	0.82	0.24	803	3.37	0.81	0.24	827	3.26	0.78	0.24	851
27	18	3.00	2.28	0.76	636	2.87	2.18	0.76	668	2.75	2.09	0.76	700	2.65	2.02	0.76	731
27	20	3.12	2.00	0.64	668	3.00	1.92	0.64	708	2.91	1.86	0.64	723	2.81	1.80	0.64	755
27	22	3.25	1.69	0.52	692	3.14	1.63	0.52	735	3.06	1.59	0.52	755	2.93	1.52	0.52	787
27	24	3.42	1.37	0.40	723	3.29	1.32	0.40	763	3.21	1.29	0.40	787	3.11	1.24	0.40	827
27	26	3.52	0.99	0.28	763	3.42	0.96	0.28	803	3.37	0.94	0.28	827	3.26	0.91	0.28	851
28	18	3.00	2.40	0.80	636	2.87	2.30	0.80	668	2.75	2.20	0.80	700	2.65	2.12	0.80	731
28	20	3.12	2.12	0.68	668	3.00	2.04	0.68	708	2.91	1.98	0.68	723	2.81	1.91	0.68	755
28	22	3.25	1.82	0.56	692	3.14	1.76	0.56	735	3.06	1.71	0.56	755	2.93	1.64	0.56	787
28	24	3.42	1.50	0.44	723	3.29	1.45	0.44	763	3.21	1.41	0.44	787	3.11	1.37	0.44	827
28	26	3.52	1.13	0.32	763	3.42	1.09	0.32	803	3.37	1.08	0.32	827	3.26	1.04	0.32	851
29	18	3.00	2.52	0.84	636	2.87	2.41	0.84	668	2.75	2.31	0.84	700	2.65	2.23	0.84	731
29	20	3.12	2.25	0.72	668	3.00	2.16	0.72	708	2.91	2.09	0.72	723	2.81	2.02	0.72	755
29	22	3.25	1.95	0.60	692	3.14	1.88	0.60	735	3.06	1.84	0.60	755	2.93	1.76	0.60	787
29	24	3.42	1.64	0.48	723	3.29	1.58	0.48	763	3.21	1.54	0.48	787	3.11	1.49	0.48	827
29	26	3.52	1.27	0.36	763	3.42	1.23	0.36	803	3.37	1.21	0.36	827	3.26	1.18	0.36	851
30	18	3.00	2.64	0.88	636	2.87	2.52	0.88	668	2.75	2.42	0.88	700	2.65	2.33	0.88	731
30	20	3.12	2.37	0.76	668	3.00	2.28	0.76	708	2.91	2.21	0.76	723	2.81	2.13	0.76	755
30	22	3.25	2.08	0.64	692	3.14	2.01	0.64	735	3.06	1.96	0.64	755	2.93	1.88	0.64	787
30	24	3.42	1.78	0.52	723	3.29	1.71	0.52	763	3.21	1.67	0.52	787	3.11	1.62	0.52	827
30	26	3.52	1.41	0.40	763	3.42	1.37	0.40	803	3.37	1.35	0.40	827	3.26	1.31	0.40	851
31	18	3.00	2.76	0.92	636	2.87	2.64	0.92	668	2.75	2.53	0.92	700	2.65	2.44	0.92	731
31	20	3.12	2.50	0.80	668	3.00	2.40	0.80	708	2.91	2.33	0.80	723	2.81	2.24	0.80	755
31	22	3.25	2.21	0.68	692	3.14	2.13	0.68	735	3.06	2.08	0.68	755	2.93	1.99	0.68	787
31	24	3.42	1.91	0.56	723	3.29	1.84	0.56	763	3.21	1.80	0.56	787	3.11	1.74	0.56	827
31	26	3.52	1.55	0.44	763	3.42	1.50	0.44	803	3.37	1.48	0.44	827	3.26	1.44	0.44	851
32	18	3.00	2.88	0.96	636	2.87	2.75	0.96	668	2.75	2.64	0.96	700	2.65	2.55	0.96	731
32	20	3.12	2.62	0.84	668	3.00	2.52	0.84	708	2.91	2.44	0.84	723	2.81	2.36	0.84	755
32	22	3.25	2.34	0.72	692	3.14	2.26	0.72	735	3.06	2.20	0.72	755	2.93	2.11	0.72	787
32	24	3.42	2.05	0.60	723	3.29	1.97	0.60	763	3.21	1.93	0.60	787	3.11	1.87	0.60	827
32	26	3.52	1.69	0.48	763	3.42	1.64	0.48	803	3.37	1.62	0.48	827	3.26	1.57	0.48	851

NOTE Q :Total capacity (kW) SHF :Sensible heat factor DB :Dry-bulb temperature
SHC :Sensible heat capacity (kW) INPUT :Total power input (W) WB :Wet-bulb temperature

PERFORMANCE DATA
COOL operation (230V)

MSC-A09YV -[E1] : MU-A09YV -[E1]

CAPACITY : 2.55(KW) SHF : 0.70 INPUT : 795(W)

		OUTDOOR DB(°C)											
INDOOR DB(°C)	INDOOR WB(°C)	35				40				43			
		Q	SHC	SHF	INPUT	Q	SHC	SHF	INPUT	Q	SHC	SHF	INPUT
21	18	2.50	1.30	0.52	779	2.30	1.19	0.52	827	2.21	1.15	0.52	843
21	20	2.63	1.05	0.40	811	2.45	0.98	0.40	851	2.36	0.94	0.40	875
22	18	2.50	1.40	0.56	779	2.30	1.29	0.56	827	2.21	1.24	0.56	843
22	20	2.63	1.16	0.44	811	2.45	1.08	0.44	851	2.36	1.04	0.44	875
22	22	2.78	0.89	0.32	843	2.60	0.83	0.32	890	2.51	0.80	0.32	906
23	18	2.50	1.50	0.60	779	2.30	1.38	0.60	827	2.21	1.32	0.60	843
23	20	2.63	1.26	0.48	811	2.45	1.18	0.48	851	2.36	1.13	0.48	875
23	22	2.78	1.00	0.36	843	2.60	0.94	0.36	890	2.51	0.90	0.36	906
24	18	2.50	1.60	0.64	779	2.30	1.47	0.64	827	2.21	1.41	0.64	843
24	20	2.63	1.37	0.52	811	2.45	1.27	0.52	851	2.36	1.23	0.52	875
24	22	2.78	1.11	0.40	843	2.60	1.04	0.40	890	2.51	1.00	0.40	906
24	24	2.93	0.82	0.28	875	2.75	0.77	0.28	914	2.68	0.75	0.28	934
25	18	2.50	1.70	0.68	779	2.30	1.56	0.68	827	2.21	1.50	0.68	843
25	20	2.63	1.47	0.56	811	2.45	1.37	0.56	851	2.36	1.32	0.56	875
25	22	2.78	1.22	0.44	843	2.60	1.14	0.44	890	2.51	1.11	0.44	906
25	24	2.93	0.94	0.32	875	2.75	0.88	0.32	914	2.68	0.86	0.32	934
26	18	2.50	1.80	0.72	779	2.30	1.65	0.72	827	2.21	1.59	0.72	843
26	20	2.63	1.58	0.60	811	2.45	1.47	0.60	851	2.36	1.42	0.60	875
26	22	2.78	1.33	0.48	843	2.60	1.25	0.48	890	2.51	1.21	0.48	906
26	24	2.93	1.06	0.36	875	2.75	0.99	0.36	914	2.68	0.96	0.36	934
26	26	3.09	0.74	0.24	906	2.91	0.70	0.24	946	2.82	0.68	0.24	966
27	18	2.50	1.90	0.76	779	2.30	1.74	0.76	827	2.21	1.68	0.76	843
27	20	2.63	1.68	0.64	811	2.45	1.57	0.64	851	2.36	1.51	0.64	875
27	22	2.78	1.45	0.52	843	2.60	1.35	0.52	890	2.51	1.31	0.52	906
27	24	2.93	1.17	0.40	875	2.75	1.10	0.40	914	2.68	1.07	0.40	934
27	26	3.09	0.86	0.28	906	2.91	0.81	0.28	946	2.82	0.79	0.28	966
28	18	2.50	2.00	0.80	779	2.30	1.84	0.80	827	2.21	1.76	0.80	843
28	20	2.63	1.79	0.68	811	2.45	1.66	0.68	851	2.36	1.60	0.68	875
28	22	2.78	1.56	0.56	843	2.60	1.46	0.56	890	2.51	1.41	0.56	906
28	24	2.93	1.29	0.44	875	2.75	1.21	0.44	914	2.68	1.18	0.44	934
28	26	3.09	0.99	0.32	906	2.91	0.93	0.32	946	2.82	0.90	0.32	966
29	18	2.50	2.10	0.84	779	2.30	1.93	0.84	827	2.21	1.85	0.84	843
29	20	2.63	1.89	0.72	811	2.45	1.76	0.72	851	2.36	1.70	0.72	875
29	22	2.78	1.67	0.60	843	2.60	1.56	0.60	890	2.51	1.51	0.60	906
29	24	2.93	1.41	0.48	875	2.75	1.32	0.48	914	2.68	1.29	0.48	934
29	26	3.09	1.11	0.36	906	2.91	1.05	0.36	946	2.82	1.01	0.36	966
30	18	2.50	2.20	0.88	779	2.30	2.02	0.88	827	2.21	1.94	0.88	843
30	20	2.63	2.00	0.76	811	2.45	1.86	0.76	851	2.36	1.79	0.76	875
30	22	2.78	1.78	0.64	843	2.60	1.66	0.64	890	2.51	1.61	0.64	906
30	24	2.93	1.52	0.52	875	2.75	1.43	0.52	914	2.68	1.39	0.52	934
30	26	3.09	1.23	0.40	906	2.91	1.16	0.40	946	2.82	1.13	0.40	966
31	18	2.50	2.30	0.92	779	2.30	2.11	0.92	827	2.21	2.03	0.92	843
31	20	2.63	2.10	0.80	811	2.45	1.96	0.80	851	2.36	1.89	0.80	875
31	22	2.78	1.89	0.68	843	2.60	1.77	0.68	890	2.51	1.71	0.68	906
31	24	2.93	1.64	0.56	875	2.75	1.54	0.56	914	2.68	1.50	0.56	934
31	26	3.09	1.36	0.44	906	2.91	1.28	0.44	946	2.82	1.24	0.44	966
32	18	2.50	2.40	0.96	779	2.30	2.20	0.96	827	2.21	2.12	0.96	843
32	20	2.63	2.21	0.84	811	2.45	2.06	0.84	851	2.36	1.98	0.84	875
32	22	2.78	2.00	0.72	843	2.60	1.87	0.72	890	2.51	1.81	0.72	906
32	24	2.93	1.76	0.60	875	2.75	1.65	0.60	914	2.68	1.61	0.60	934
32	26	3.09	1.48	0.48	906	2.91	1.40	0.48	946	2.82	1.35	0.48	966

NOTE Q :Total capacity (kW) SHF :Sensible heat factor DB :Dry-bulb temperature
 SHC :Sensible heat capacity (kW) INPUT :Total power input (W) WB :Wet-bulb temperature

PERFORMANCE DATA
COOL operation (230V)

MSC-A12YV -[E1] : MU-A12YV -[E1]

CAPACITY : 3.5(KW) SHF : 0.66 INPUT : 1140(W)

		OUTDOOR DB(°C)															
INDOOR DB(°C)	INDOOR WB(°C)	21				25				27				30			
		Q	SHC	SHF	INPUT	Q	SHC	SHF	INPUT	Q	SHC	SHF	INPUT	Q	SHC	SHF	INPUT
21	18	4.11	1.97	0.48	912	3.94	1.89	0.48	958	3.78	1.81	0.48	1003	3.64	1.75	0.48	1049
21	20	4.29	1.54	0.36	958	4.11	1.48	0.36	1015	3.99	1.44	0.36	1037	3.85	1.39	0.36	1083
22	18	4.11	2.14	0.52	912	3.94	2.05	0.52	958	3.78	1.97	0.52	1003	3.64	1.89	0.52	1049
22	20	4.29	1.72	0.40	958	4.11	1.65	0.40	1015	3.99	1.60	0.40	1037	3.85	1.54	0.40	1083
22	22	4.46	1.25	0.28	992	4.31	1.21	0.28	1055	4.20	1.18	0.28	1083	4.03	1.13	0.28	1129
23	18	4.11	2.30	0.56	912	3.94	2.21	0.56	958	3.78	2.12	0.56	1003	3.64	2.04	0.56	1049
23	20	4.29	1.89	0.44	958	4.11	1.81	0.44	1015	3.99	1.76	0.44	1037	3.85	1.69	0.44	1083
23	22	4.46	1.43	0.32	992	4.31	1.38	0.32	1055	4.20	1.34	0.32	1083	4.03	1.29	0.32	1129
24	18	4.11	2.47	0.60	912	3.94	2.36	0.60	958	3.78	2.27	0.60	1003	3.64	2.18	0.60	1049
24	20	4.29	2.06	0.48	958	4.11	1.97	0.48	1015	3.99	1.92	0.48	1037	3.85	1.85	0.48	1083
24	22	4.46	1.61	0.36	992	4.31	1.55	0.36	1055	4.20	1.51	0.36	1083	4.03	1.45	0.36	1129
24	24	4.69	1.13	0.24	1037	4.52	1.08	0.24	1094	4.41	1.06	0.24	1129	4.27	1.02	0.24	1186
25	18	4.11	2.63	0.64	912	3.94	2.52	0.64	958	3.78	2.42	0.64	1003	3.64	2.33	0.64	1049
25	20	4.29	2.23	0.52	958	4.11	2.14	0.52	1015	3.99	2.07	0.52	1037	3.85	2.00	0.52	1083
25	22	4.46	1.79	0.40	992	4.31	1.72	0.40	1055	4.20	1.68	0.40	1083	4.03	1.61	0.40	1129
25	24	4.69	1.31	0.28	1037	4.52	1.26	0.28	1094	4.41	1.23	0.28	1129	4.27	1.20	0.28	1186
26	18	4.11	2.80	0.68	912	3.94	2.68	0.68	958	3.78	2.57	0.68	1003	3.64	2.48	0.68	1049
26	20	4.29	2.40	0.56	958	4.11	2.30	0.56	1015	3.99	2.23	0.56	1037	3.85	2.16	0.56	1083
26	22	4.46	1.96	0.44	992	4.31	1.89	0.44	1055	4.20	1.85	0.44	1083	4.03	1.77	0.44	1129
26	24	4.69	1.50	0.32	1037	4.52	1.44	0.32	1094	4.41	1.41	0.32	1129	4.27	1.37	0.32	1186
26	26	4.83	0.97	0.20	1094	4.69	0.94	0.20	1151	4.62	0.92	0.20	1186	4.48	0.90	0.20	1220
27	18	4.11	2.96	0.72	912	3.94	2.84	0.72	958	3.78	2.72	0.72	1003	3.64	2.62	0.72	1049
27	20	4.29	2.57	0.60	958	4.11	2.47	0.60	1015	3.99	2.39	0.60	1037	3.85	2.31	0.60	1083
27	22	4.46	2.14	0.48	992	4.31	2.07	0.48	1055	4.20	2.02	0.48	1083	4.03	1.93	0.48	1129
27	24	4.69	1.69	0.36	1037	4.52	1.63	0.36	1094	4.41	1.59	0.36	1129	4.27	1.54	0.36	1186
27	26	4.83	1.16	0.24	1094	4.69	1.13	0.24	1151	4.62	1.11	0.24	1186	4.48	1.08	0.24	1220
28	18	4.11	3.13	0.76	912	3.94	2.99	0.76	958	3.78	2.87	0.76	1003	3.64	2.77	0.76	1049
28	20	4.29	2.74	0.64	958	4.11	2.63	0.64	1015	3.99	2.55	0.64	1037	3.85	2.46	0.64	1083
28	22	4.46	2.32	0.52	992	4.31	2.24	0.52	1055	4.20	2.18	0.52	1083	4.03	2.09	0.52	1129
28	24	4.69	1.88	0.40	1037	4.52	1.81	0.40	1094	4.41	1.76	0.40	1129	4.27	1.71	0.40	1186
28	26	4.83	1.35	0.28	1094	4.69	1.31	0.28	1151	4.62	1.29	0.28	1186	4.48	1.25	0.28	1220
29	18	4.11	3.29	0.80	912	3.94	3.15	0.80	958	3.78	3.02	0.80	1003	3.64	2.91	0.80	1049
29	20	4.29	2.92	0.68	958	4.11	2.80	0.68	1015	3.99	2.71	0.68	1037	3.85	2.62	0.68	1083
29	22	4.46	2.50	0.56	992	4.31	2.41	0.56	1055	4.20	2.35	0.56	1083	4.03	2.25	0.56	1129
29	24	4.69	2.06	0.44	1037	4.52	1.99	0.44	1094	4.41	1.94	0.44	1129	4.27	1.88	0.44	1186
29	26	4.83	1.55	0.32	1094	4.69	1.50	0.32	1151	4.62	1.48	0.32	1186	4.48	1.43	0.32	1220
30	18	4.11	3.45	0.84	912	3.94	3.31	0.84	958	3.78	3.18	0.84	1003	3.64	3.06	0.84	1049
30	20	4.29	3.09	0.72	958	4.11	2.96	0.72	1015	3.99	2.87	0.72	1037	3.85	2.77	0.72	1083
30	22	4.46	2.68	0.60	992	4.31	2.58	0.60	1055	4.20	2.52	0.60	1083	4.03	2.42	0.60	1129
30	24	4.69	2.25	0.48	1037	4.52	2.17	0.48	1094	4.41	2.12	0.48	1129	4.27	2.05	0.48	1186
30	26	4.83	1.74	0.36	1094	4.69	1.69	0.36	1151	4.62	1.66	0.36	1186	4.48	1.61	0.36	1220
31	18	4.11	3.62	0.88	912	3.94	3.47	0.88	958	3.78	3.33	0.88	1003	3.64	3.20	0.88	1049
31	20	4.29	3.26	0.76	958	4.11	3.13	0.76	1015	3.99	3.03	0.76	1037	3.85	2.93	0.76	1083
31	22	4.46	2.86	0.64	992	4.31	2.76	0.64	1055	4.20	2.69	0.64	1083	4.03	2.58	0.64	1129
31	24	4.69	2.44	0.52	1037	4.52	2.35	0.52	1094	4.41	2.29	0.52	1129	4.27	2.22	0.52	1186
31	26	4.83	1.93	0.40	1094	4.69	1.88	0.40	1151	4.62	1.85	0.40	1186	4.48	1.79	0.40	1220
32	18	4.11	3.78	0.92	912	3.94	3.62	0.92	958	3.78	3.48	0.92	1003	3.64	3.35	0.92	1049
32	20	4.29	3.43	0.80	958	4.11	3.29	0.80	1015	3.99	3.19	0.80	1037	3.85	3.08	0.80	1083
32	22	4.46	3.03	0.68	992	4.31	2.93	0.68	1055	4.20	2.86	0.68	1083	4.03	2.74	0.68	1129
32	24	4.69	2.63	0.56	1037	4.52	2.53	0.56	1094	4.41	2.47	0.56	1129	4.27	2.39	0.56	1186
32	26	4.83	2.13	0.44	1094	4.69	2.06	0.44	1151	4.62	2.03	0.44	1186	4.48	1.97	0.44	1220

NOTE Q :Total capacity (kW) SHF :Sensible heat factor DB :Dry-bulb temperature
 SHC :Sensible heat capacity (kW) INPUT :Total power input (W) WB :Wet-bulb temperature

PERFORMANCE DATA

COOL operation (230V)

MSC-A12YV -[E1] : MU-A12YV -[E1]

CAPACITY : 3.5(KW) SHF : 0.66 INPUT : 1140(W)

		OUTDOOR DB(°C)											
INDOOR DB(°C)	INDOOR WB(°C)	35				40				43			
		Q	SHC	SHF	INPUT	Q	SHC	SHF	INPUT	Q	SHC	SHF	INPUT
21	18	3.43	1.65	0.48	1117	3.15	1.51	0.48	1186	3.03	1.45	0.48	1208
21	20	3.61	1.30	0.36	1163	3.36	1.21	0.36	1220	3.24	1.17	0.36	1254
22	18	3.43	1.78	0.52	1117	3.15	1.64	0.52	1186	3.03	1.57	0.52	1208
22	20	3.61	1.44	0.40	1163	3.36	1.34	0.40	1220	3.24	1.30	0.40	1254
22	22	3.82	1.07	0.28	1208	3.57	1.00	0.28	1277	3.45	0.97	0.28	1300
23	18	3.43	1.92	0.56	1117	3.15	1.76	0.56	1186	3.03	1.70	0.56	1208
23	20	3.61	1.59	0.44	1163	3.36	1.48	0.44	1220	3.24	1.42	0.44	1254
23	22	3.82	1.22	0.32	1208	3.57	1.14	0.32	1277	3.45	1.10	0.32	1300
24	18	3.43	2.06	0.60	1117	3.15	1.89	0.60	1186	3.03	1.82	0.60	1208
24	20	3.61	1.73	0.48	1163	3.36	1.61	0.48	1220	3.24	1.55	0.48	1254
24	22	3.82	1.37	0.36	1208	3.57	1.29	0.36	1277	3.45	1.24	0.36	1300
24	24	4.03	0.97	0.24	1254	3.78	0.91	0.24	1311	3.68	0.88	0.24	1340
25	18	3.43	2.20	0.64	1117	3.15	2.02	0.64	1186	3.03	1.94	0.64	1208
25	20	3.61	1.87	0.52	1163	3.36	1.75	0.52	1220	3.24	1.68	0.52	1254
25	22	3.82	1.53	0.40	1208	3.57	1.43	0.40	1277	3.45	1.38	0.40	1300
25	24	4.03	1.13	0.28	1254	3.78	1.06	0.28	1311	3.68	1.03	0.28	1340
26	18	3.43	2.33	0.68	1117	3.15	2.14	0.68	1186	3.03	2.06	0.68	1208
26	20	3.61	2.02	0.56	1163	3.36	1.88	0.56	1220	3.24	1.81	0.56	1254
26	22	3.82	1.68	0.44	1208	3.57	1.57	0.44	1277	3.45	1.52	0.44	1300
26	24	4.03	1.29	0.32	1254	3.78	1.21	0.32	1311	3.68	1.18	0.32	1340
26	26	4.24	0.85	0.20	1300	3.99	0.80	0.20	1357	3.87	0.77	0.20	1385
27	18	3.43	2.47	0.72	1117	3.15	2.27	0.72	1186	3.03	2.18	0.72	1208
27	20	3.61	2.16	0.60	1163	3.36	2.02	0.60	1220	3.24	1.94	0.60	1254
27	22	3.82	1.83	0.48	1208	3.57	1.71	0.48	1277	3.45	1.65	0.48	1300
27	24	4.03	1.45	0.36	1254	3.78	1.36	0.36	1311	3.68	1.32	0.36	1340
27	26	4.24	1.02	0.24	1300	3.99	0.96	0.24	1357	3.87	0.93	0.24	1385
28	18	3.43	2.61	0.76	1117	3.15	2.39	0.76	1186	3.03	2.30	0.76	1208
28	20	3.61	2.31	0.64	1163	3.36	2.15	0.64	1220	3.24	2.07	0.64	1254
28	22	3.82	1.98	0.52	1208	3.57	1.86	0.52	1277	3.45	1.79	0.52	1300
28	24	4.03	1.61	0.40	1254	3.78	1.51	0.40	1311	3.68	1.47	0.40	1340
28	26	4.24	1.19	0.28	1300	3.99	1.12	0.28	1357	3.87	1.08	0.28	1385
29	18	3.43	2.74	0.80	1117	3.15	2.52	0.80	1186	3.03	2.42	0.80	1208
29	20	3.61	2.45	0.68	1163	3.36	2.28	0.68	1220	3.24	2.20	0.68	1254
29	22	3.82	2.14	0.56	1208	3.57	2.00	0.56	1277	3.45	1.93	0.56	1300
29	24	4.03	1.77	0.44	1254	3.78	1.66	0.44	1311	3.68	1.62	0.44	1340
29	26	4.24	1.36	0.32	1300	3.99	1.28	0.32	1357	3.87	1.24	0.32	1385
30	18	3.43	2.88	0.84	1117	3.15	2.65	0.84	1186	3.03	2.54	0.84	1208
30	20	3.61	2.60	0.72	1163	3.36	2.42	0.72	1220	3.24	2.33	0.72	1254
30	22	3.82	2.29	0.60	1208	3.57	2.14	0.60	1277	3.45	2.07	0.60	1300
30	24	4.03	1.93	0.48	1254	3.78	1.81	0.48	1311	3.68	1.76	0.48	1340
30	26	4.24	1.52	0.36	1300	3.99	1.44	0.36	1357	3.87	1.39	0.36	1385
31	18	3.43	3.02	0.88	1117	3.15	2.77	0.88	1186	3.03	2.66	0.88	1208
31	20	3.61	2.74	0.76	1163	3.36	2.55	0.76	1220	3.24	2.46	0.76	1254
31	22	3.82	2.44	0.64	1208	3.57	2.28	0.64	1277	3.45	2.21	0.64	1300
31	24	4.03	2.09	0.52	1254	3.78	1.97	0.52	1311	3.68	1.91	0.52	1340
31	26	4.24	1.69	0.40	1300	3.99	1.60	0.40	1357	3.87	1.55	0.40	1385
32	18	3.43	3.16	0.92	1117	3.15	2.90	0.92	1186	3.03	2.79	0.92	1208
32	20	3.61	2.88	0.80	1163	3.36	2.69	0.80	1220	3.24	2.59	0.80	1254
32	22	3.82	2.59	0.68	1208	3.57	2.43	0.68	1277	3.45	2.34	0.68	1300
32	24	4.03	2.25	0.56	1254	3.78	2.12	0.56	1311	3.68	2.06	0.56	1340
32	26	4.24	1.86	0.44	1300	3.99	1.76	0.44	1357	3.87	1.70	0.44	1385

NOTE Q :Total capacity (kW) SHF :Sensible heat factor DB :Dry-bulb temperature
 SHC :Sensible heat capacity (kW) INPUT :Total power input (W) WB :Wet-bulb temperature

PERFORMANCE DATA

COOL operation (230V)

MCF-A12WV -[E1] : MU-A12YV -[E1]

CAPACITY :3.5(KW) SHF :0.70 INPUT :1160(W)

		OUTDOOR DB(°C)															
INDOOR DB(°C)	INDOOR WB(°C)	21				25				27				30			
		Q	SHC	SHF	INPUT	Q	SHC	SHF	INPUT	Q	SHC	SHF	INPUT	Q	SHC	SHF	INPUT
21	18	4.11	2.14	0.52	928	3.94	2.05	0.52	974	3.78	1.97	0.52	1021	3.64	1.89	0.52	1067
21	20	4.29	1.72	0.40	974	4.11	1.65	0.40	1032	3.99	1.60	0.40	1056	3.85	1.54	0.40	1102
22	18	4.11	2.30	0.56	928	3.94	2.21	0.56	974	3.78	2.12	0.56	1021	3.64	2.04	0.56	1067
22	20	4.29	1.89	0.44	974	4.11	1.81	0.44	1032	3.99	1.76	0.44	1056	3.85	1.69	0.44	1102
22	22	4.46	1.43	0.32	1009	4.31	1.38	0.32	1073	4.20	1.34	0.32	1102	4.03	1.29	0.32	1148
23	18	4.11	2.47	0.60	928	3.94	2.36	0.60	974	3.78	2.27	0.60	1021	3.64	2.18	0.60	1067
23	20	4.29	2.06	0.48	974	4.11	1.97	0.48	1032	3.99	1.92	0.48	1056	3.85	1.85	0.48	1102
23	22	4.46	1.61	0.36	1009	4.31	1.55	0.36	1073	4.20	1.51	0.36	1102	4.03	1.45	0.36	1148
24	18	4.11	2.63	0.64	928	3.94	2.52	0.64	974	3.78	2.42	0.64	1021	3.64	2.33	0.64	1067
24	20	4.29	2.23	0.52	974	4.11	2.14	0.52	1032	3.99	2.07	0.52	1056	3.85	2.00	0.52	1102
24	22	4.46	1.79	0.40	1009	4.31	1.72	0.40	1073	4.20	1.68	0.40	1102	4.03	1.61	0.40	1148
24	24	4.69	1.31	0.28	1056	4.52	1.26	0.28	1114	4.41	1.23	0.28	1148	4.27	1.20	0.28	1206
25	18	4.11	2.80	0.68	928	3.94	2.68	0.68	974	3.78	2.57	0.68	1021	3.64	2.48	0.68	1067
25	20	4.29	2.40	0.56	974	4.11	2.30	0.56	1032	3.99	2.23	0.56	1056	3.85	2.16	0.56	1102
25	22	4.46	1.96	0.44	1009	4.31	1.89	0.44	1073	4.20	1.85	0.44	1102	4.03	1.77	0.44	1148
25	24	4.69	1.50	0.32	1056	4.52	1.44	0.32	1114	4.41	1.41	0.32	1148	4.27	1.37	0.32	1206
26	18	4.11	2.96	0.72	928	3.94	2.84	0.72	974	3.78	2.72	0.72	1021	3.64	2.62	0.72	1067
26	20	4.29	2.57	0.60	974	4.11	2.47	0.60	1032	3.99	2.39	0.60	1056	3.85	2.31	0.60	1102
26	22	4.46	2.14	0.48	1009	4.31	2.07	0.48	1073	4.20	2.02	0.48	1102	4.03	1.93	0.48	1148
26	24	4.69	1.69	0.36	1056	4.52	1.63	0.36	1114	4.41	1.59	0.36	1148	4.27	1.54	0.36	1206
26	26	4.83	1.16	0.24	1114	4.69	1.13	0.24	1172	4.62	1.11	0.24	1206	4.48	1.08	0.24	1241
27	18	4.11	3.13	0.76	928	3.94	2.99	0.76	974	3.78	2.87	0.76	1021	3.64	2.77	0.76	1067
27	20	4.29	2.74	0.64	974	4.11	2.63	0.64	1032	3.99	2.55	0.64	1056	3.85	2.46	0.64	1102
27	22	4.46	2.32	0.52	1009	4.31	2.24	0.52	1073	4.20	2.18	0.52	1102	4.03	2.09	0.52	1148
27	24	4.69	1.88	0.40	1056	4.52	1.81	0.40	1114	4.41	1.76	0.40	1148	4.27	1.71	0.40	1206
27	26	4.83	1.35	0.28	1114	4.69	1.31	0.28	1172	4.62	1.29	0.28	1206	4.48	1.25	0.28	1241
28	18	4.11	3.29	0.80	928	3.94	3.15	0.80	974	3.78	3.02	0.80	1021	3.64	2.91	0.80	1067
28	20	4.29	2.92	0.68	974	4.11	2.80	0.68	1032	3.99	2.71	0.68	1056	3.85	2.62	0.68	1102
28	22	4.46	2.50	0.56	1009	4.31	2.41	0.56	1073	4.20	2.35	0.56	1102	4.03	2.25	0.56	1148
28	24	4.69	2.06	0.44	1056	4.52	1.99	0.44	1114	4.41	1.94	0.44	1148	4.27	1.88	0.44	1206
28	26	4.83	1.55	0.32	1114	4.69	1.50	0.32	1172	4.62	1.48	0.32	1206	4.48	1.43	0.32	1241
29	18	4.11	3.45	0.84	928	3.94	3.31	0.84	974	3.78	3.18	0.84	1021	3.64	3.06	0.84	1067
29	20	4.29	3.09	0.72	974	4.11	2.96	0.72	1032	3.99	2.87	0.72	1056	3.85	2.77	0.72	1102
29	22	4.46	2.68	0.60	1009	4.31	2.58	0.60	1073	4.20	2.52	0.60	1102	4.03	2.42	0.60	1148
29	24	4.69	2.25	0.48	1056	4.52	2.17	0.48	1114	4.41	2.12	0.48	1148	4.27	2.05	0.48	1206
29	26	4.83	1.74	0.36	1114	4.69	1.69	0.36	1172	4.62	1.66	0.36	1206	4.48	1.61	0.36	1241
30	18	4.11	3.62	0.88	928	3.94	3.47	0.88	974	3.78	3.33	0.88	1021	3.64	3.20	0.88	1067
30	20	4.29	3.26	0.76	974	4.11	3.13	0.76	1032	3.99	3.03	0.76	1056	3.85	2.93	0.76	1102
30	22	4.46	2.86	0.64	1009	4.31	2.76	0.64	1073	4.20	2.69	0.64	1102	4.03	2.58	0.64	1148
30	24	4.69	2.44	0.52	1056	4.52	2.35	0.52	1114	4.41	2.29	0.52	1148	4.27	2.22	0.52	1206
30	26	4.83	1.93	0.40	1114	4.69	1.88	0.40	1172	4.62	1.85	0.40	1206	4.48	1.79	0.40	1241
31	18	4.11	3.78	0.92	928	3.94	3.62	0.92	974	3.78	3.48	0.92	1021	3.64	3.35	0.92	1067
31	20	4.29	3.43	0.80	974	4.11	3.29	0.80	1032	3.99	3.19	0.80	1056	3.85	3.08	0.80	1102
31	22	4.46	3.03	0.68	1009	4.31	2.93	0.68	1073	4.20	2.86	0.68	1102	4.03	2.74	0.68	1148
31	24	4.69	2.63	0.56	1056	4.52	2.53	0.56	1114	4.41	2.47	0.56	1148	4.27	2.39	0.56	1206
31	26	4.83	2.13	0.44	1114	4.69	2.06	0.44	1172	4.62	2.03	0.44	1206	4.48	1.97	0.44	1241
32	18	4.11	3.95	0.96	928	3.94	3.78	0.96	974	3.78	3.63	0.96	1021	3.64	3.49	0.96	1067
32	20	4.29	3.60	0.84	974	4.11	3.45	0.84	1032	3.99	3.35	0.84	1056	3.85	3.23	0.84	1102
32	22	4.46	3.21	0.72	1009	4.31	3.10	0.72	1073	4.20	3.02	0.72	1102	4.03	2.90	0.72	1148
32	24	4.69	2.81	0.60	1056	4.52	2.71	0.60	1114	4.41	2.65	0.60	1148	4.27	2.56	0.60	1206
32	26	4.83	2.32	0.48	1114	4.69	2.25	0.48	1172	4.62	2.22	0.48	1206	4.48	2.15	0.48	1241

NOTE Q :Total capacity (kW) SHF :Sensible heat factor DB :Dry-bulb temperature
 SHC :Sensible heat capacity (kW) INPUT :Total power input (W) WB :Wet-bulb temperature

PERFORMANCE DATA

COOL operation (230V)

MCF-A12WV -[E1] : MU-A12YV -[E1]

CAPACITY :3.5(KW) SHF :0.70 INPUT :1160(W)

		OUTDOOR DB(°C)											
INDOOR DB(°C)	INDOOR WB(°C)	35				40				43			
		Q	SHC	SHF	INPUT	Q	SHC	SHF	INPUT	Q	SHC	SHF	INPUT
21	18	3.43	1.78	0.52	1137	3.15	1.64	0.52	1206	3.03	1.57	0.52	1230
21	20	3.61	1.44	0.40	1183	3.36	1.34	0.40	1241	3.24	1.30	0.40	1276
22	18	3.43	1.92	0.56	1137	3.15	1.76	0.56	1206	3.03	1.70	0.56	1230
22	20	3.61	1.59	0.44	1183	3.36	1.48	0.44	1241	3.24	1.42	0.44	1276
22	22	3.82	1.22	0.32	1230	3.57	1.14	0.32	1299	3.45	1.10	0.32	1322
23	18	3.43	2.06	0.60	1137	3.15	1.89	0.60	1206	3.03	1.82	0.60	1230
23	20	3.61	1.73	0.48	1183	3.36	1.61	0.48	1241	3.24	1.55	0.48	1276
23	22	3.82	1.37	0.36	1230	3.57	1.29	0.36	1299	3.45	1.24	0.36	1322
24	18	3.43	2.20	0.64	1137	3.15	2.02	0.64	1206	3.03	1.94	0.64	1230
24	20	3.61	1.87	0.52	1183	3.36	1.75	0.52	1241	3.24	1.68	0.52	1276
24	22	3.82	1.53	0.40	1230	3.57	1.43	0.40	1299	3.45	1.38	0.40	1322
24	24	4.03	1.13	0.28	1276	3.78	1.06	0.28	1334	3.68	1.03	0.28	1363
25	18	3.43	2.33	0.68	1137	3.15	2.14	0.68	1206	3.03	2.06	0.68	1230
25	20	3.61	2.02	0.56	1183	3.36	1.88	0.56	1241	3.24	1.81	0.56	1276
25	22	3.82	1.68	0.44	1230	3.57	1.57	0.44	1299	3.45	1.52	0.44	1322
25	24	4.03	1.29	0.32	1276	3.78	1.21	0.32	1334	3.68	1.18	0.32	1363
26	18	3.43	2.47	0.72	1137	3.15	2.27	0.72	1206	3.03	2.18	0.72	1230
26	20	3.61	2.16	0.60	1183	3.36	2.02	0.60	1241	3.24	1.94	0.60	1276
26	22	3.82	1.83	0.48	1230	3.57	1.71	0.48	1299	3.45	1.65	0.48	1322
26	24	4.03	1.45	0.36	1276	3.78	1.36	0.36	1334	3.68	1.32	0.36	1363
26	26	4.24	1.02	0.24	1322	3.99	0.96	0.24	1380	3.87	0.93	0.24	1409
27	18	3.43	2.61	0.76	1137	3.15	2.39	0.76	1206	3.03	2.30	0.76	1230
27	20	3.61	2.31	0.64	1183	3.36	2.15	0.64	1241	3.24	2.07	0.64	1276
27	22	3.82	1.98	0.52	1230	3.57	1.86	0.52	1299	3.45	1.79	0.52	1322
27	24	4.03	1.61	0.40	1276	3.78	1.51	0.40	1334	3.68	1.47	0.40	1363
27	26	4.24	1.19	0.28	1322	3.99	1.12	0.28	1380	3.87	1.08	0.28	1409
28	18	3.43	2.74	0.80	1137	3.15	2.52	0.80	1206	3.03	2.42	0.80	1230
28	20	3.61	2.45	0.68	1183	3.36	2.28	0.68	1241	3.24	2.20	0.68	1276
28	22	3.82	2.14	0.56	1230	3.57	2.00	0.56	1299	3.45	1.93	0.56	1322
28	24	4.03	1.77	0.44	1276	3.78	1.66	0.44	1334	3.68	1.62	0.44	1363
28	26	4.24	1.36	0.32	1322	3.99	1.28	0.32	1380	3.87	1.24	0.32	1409
29	18	3.43	2.88	0.84	1137	3.15	2.65	0.84	1206	3.03	2.54	0.84	1230
29	20	3.61	2.60	0.72	1183	3.36	2.42	0.72	1241	3.24	2.33	0.72	1276
29	22	3.82	2.29	0.60	1230	3.57	2.14	0.60	1299	3.45	2.07	0.60	1322
29	24	4.03	1.93	0.48	1276	3.78	1.81	0.48	1334	3.68	1.76	0.48	1363
29	26	4.24	1.52	0.36	1322	3.99	1.44	0.36	1380	3.87	1.39	0.36	1409
30	18	3.43	3.02	0.88	1137	3.15	2.77	0.88	1206	3.03	2.66	0.88	1230
30	20	3.61	2.74	0.76	1183	3.36	2.55	0.76	1241	3.24	2.46	0.76	1276
30	22	3.82	2.44	0.64	1230	3.57	2.28	0.64	1299	3.45	2.21	0.64	1322
30	24	4.03	2.09	0.52	1276	3.78	1.97	0.52	1334	3.68	1.91	0.52	1363
30	26	4.24	1.69	0.40	1322	3.99	1.60	0.40	1380	3.87	1.55	0.40	1409
31	18	3.43	3.16	0.92	1137	3.15	2.90	0.92	1206	3.03	2.79	0.92	1230
31	20	3.61	2.88	0.80	1183	3.36	2.69	0.80	1241	3.24	2.59	0.80	1276
31	22	3.82	2.59	0.68	1230	3.57	2.43	0.68	1299	3.45	2.34	0.68	1322
31	24	4.03	2.25	0.56	1276	3.78	2.12	0.56	1334	3.68	2.06	0.56	1363
31	26	4.24	1.86	0.44	1322	3.99	1.76	0.44	1380	3.87	1.70	0.44	1409
32	18	3.43	3.29	0.96	1137	3.15	3.02	0.96	1206	3.03	2.91	0.96	1230
32	20	3.61	3.03	0.84	1183	3.36	2.82	0.84	1241	3.24	2.72	0.84	1276
32	22	3.82	2.75	0.72	1230	3.57	2.57	0.72	1299	3.45	2.48	0.72	1322
32	24	4.03	2.42	0.60	1276	3.78	2.27	0.60	1334	3.68	2.21	0.60	1363
32	26	4.24	2.03	0.48	1322	3.99	1.92	0.48	1380	3.87	1.86	0.48	1409

NOTE Q :Total capacity (kW) SHF :Sensible heat factor DB :Dry-bulb temperature
 SHC :Sensible heat capacity (kW) INPUT :Total power input (W) WB :Wet-bulb temperature

MU-A07YV -[E1]

MU-A09YV -[E1]

MU-A12YV -[E1]

9-1. Cautions on troubleshooting

1. Before troubleshooting, check the following:

- 1) Check the power supply voltage.
- 2) Check the indoor/outdoor connecting wire for mis-wiring.

2. Take care the following during servicing.

- 1) Before servicing the air conditioner, be sure to first turn off the remote controller to stop the unit, and then after confirming the horizontal vane is closed, turn off the breaker and/or disconnect the power plug.
- 2) Be sure to turn OFF the power supply before removing the front panel, the cabinet, the top panel, and the electronic control P.C. board.
- 3) When removing the electronic control P.C. board, hold the edge of the board with care NOT to apply stress on the components.
- 4) When connecting or disconnecting the connectors, hold the housing of the connector. DO NOT pull the lead wires.

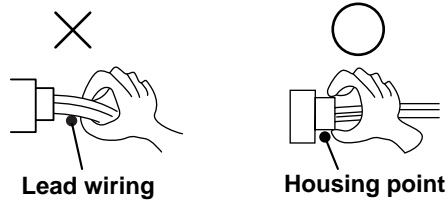

9-2. Instruction of troubleshooting

MU-A07YV -E1

MU-A09YV -E1

MU-A12YV -E1

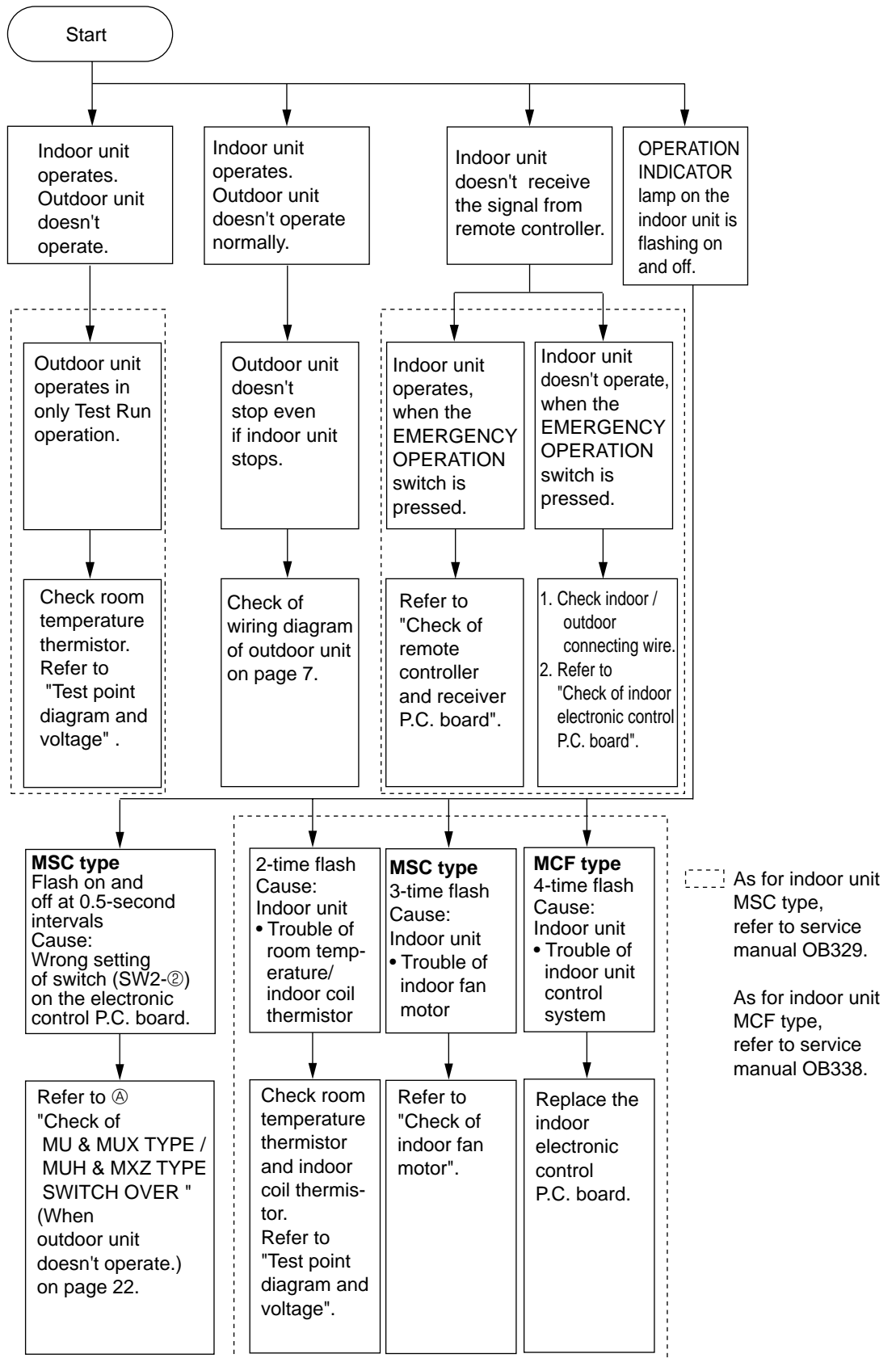

*1.<The case of the trouble of the serial signal>
When the power is turned off and then turned on again, the indication shows "the trouble of mis-wiring".

9-3. Trouble criterion of main parts

MU-A07YV -[E1]

MU-A09YV -[E1]

MU-A12YV -[E1]

Part name	Check method and criterion	Figure																	
Compressor (MC) INNER PROTECTOR MU-A07/A09YV 150± 5°C OPEN 90±10°C CLOSE MU-A12YV 155± 5°C OPEN 90±10°C CLOSE	Measure the resistance between the terminals with a tester. (Coil wiring temperature -10°C ~ 40°C) <table border="1" style="margin-top: 10px;"> <thead> <tr> <th rowspan="2"></th> <th colspan="3">Normal</th> <th rowspan="2">Abnormal</th> </tr> <tr> <th>MU-A07YV</th> <th>MU-A09YV</th> <th>MU-A12YV</th> </tr> </thead> <tbody> <tr> <td>C-R</td> <td>3.41~4.18Ω</td> <td>2.99~3.67Ω</td> <td>2.46~3.01Ω</td> <td rowspan="2">Open or short-circuit</td> </tr> <tr> <td>C-S</td> <td>5.41~6.63Ω</td> <td>4.02~4.92Ω</td> <td>2.96~3.63Ω</td> </tr> </tbody> </table>		Normal			Abnormal	MU-A07YV	MU-A09YV	MU-A12YV	C-R	3.41~4.18Ω	2.99~3.67Ω	2.46~3.01Ω	Open or short-circuit	C-S	5.41~6.63Ω	4.02~4.92Ω	2.96~3.63Ω	
	Normal			Abnormal															
	MU-A07YV	MU-A09YV	MU-A12YV																
C-R	3.41~4.18Ω	2.99~3.67Ω	2.46~3.01Ω	Open or short-circuit															
C-S	5.41~6.63Ω	4.02~4.92Ω	2.96~3.63Ω																
Outdoor fan motor (MF) INNER PROTECTOR MU-A07/A09YV 130± 5°C OPEN 83±15°C CLOSE INNER FUSE MU-A12YV 145± 2°C CUT OFF	Measure the resistance between the terminals with a tester. (Coil wiring temperature -10°C ~ 40°C) <table border="1" style="margin-top: 10px;"> <thead> <tr> <th rowspan="2">Color of lead wire</th> <th colspan="2">Normal</th> <th rowspan="2">Abnormal</th> </tr> <tr> <th>MU-A07/A09YV</th> <th>MU-A12YV</th> </tr> </thead> <tbody> <tr> <td>WHT-BLK</td> <td>361 ~ 443Ω</td> <td>196 ~ 241Ω</td> <td rowspan="2">Open or short-circuit</td> </tr> <tr> <td>BLK-RED</td> <td>381 ~ 468Ω</td> <td>201 ~ 246Ω</td> </tr> </tbody> </table>	Color of lead wire	Normal		Abnormal	MU-A07/A09YV	MU-A12YV	WHT-BLK	361 ~ 443Ω	196 ~ 241Ω	Open or short-circuit	BLK-RED	381 ~ 468Ω	201 ~ 246Ω	MU-A07/A09YV MU-A12YV 				
Color of lead wire	Normal		Abnormal																
	MU-A07/A09YV	MU-A12YV																	
WHT-BLK	361 ~ 443Ω	196 ~ 241Ω	Open or short-circuit																
BLK-RED	381 ~ 468Ω	201 ~ 246Ω																	

(P) INNER PROTECTOR

Indoor unit MSC type

When OPERATION INDICATOR lamp flashes 0.5-second intervals.
 Outdoor unit doesn't operate.

Ⓐ Check of MU & MUX TYPE / MUH & MXZ TYPE SWITCH OVER

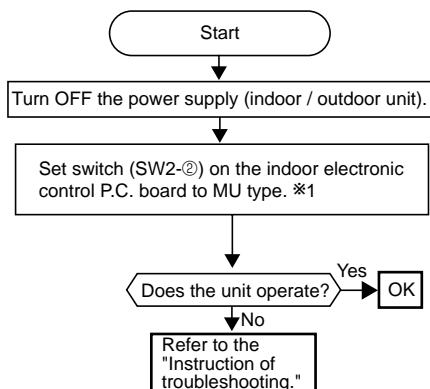

※ 1 Set the switch (SW2-②) on indoor electronic control P.C. board to MU type, when the outdoor unit is MU type.
 If the setting is MUH or MXZ type, the unit does not work.
 Refer to 9-4. MU & MUX TYPE / MUH & MXZ TYPE SWITCH OVER AND AUTO RESTART FUNCTION on service manual OB329.

<"Terminal with lock mechanism" Detaching points>

In case of terminal with lock mechanism, detach the terminal as shown below.
There are two types (Refer to (1) and (2)) of the terminal with lock mechanism.
The terminal with no lock mechanism can be removed by pulling it out.
Check the shape of the terminal and work.

(1) Slide the sleeve and check if there is a locking lever or not.

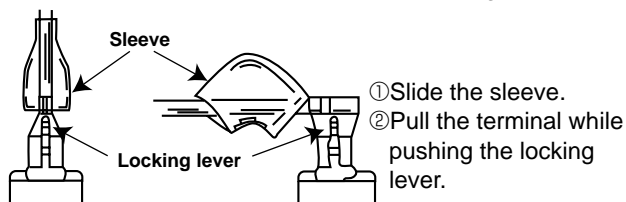

(2) The terminal with this connector is a terminal with lock mechanism

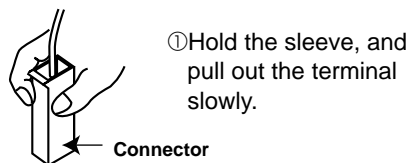

MU-A07YV -E1 MU-A09YV -E1 MU-A12YV -E1
OUTDOOR UNIT

OPERATING PROCEDURE	PHOTOS
<p>1. Removing the cabinet</p> <ol style="list-style-type: none"> (1) Remove the screws of the top panel. (2) Remove the screw of the service panel. (3) Remove the screws of the cabinet. (4) Remove the screws of the front panel and motor support. (5) Remove the service panel, and remove the screw from the insides. (6) Remove the top panel. (7) Remove the cabinet. <p>Photo 3</p> <p>Screws of the service panel Screws of the top panel Service panel</p>	<p>Photo 1</p> <p>Screws of the front panel and motor support</p> <p>Screws of the cabinet</p> <p>Screws of the cabinet</p> <p>Photo 2</p> <p>Screws of the top panel</p> <p>Screws of the cabinet</p>

OPERATING PROCEDURE

2. Removing the electrical parts

- (1) Remove the service panel and the cabinet.(Refer to 1.)
- (2) Remove the following parts.
 - Compressor capacitor (C1)
 - Outdoor fan capacitor (C2)
 - Terminal block

PHOTOS

Photo 4

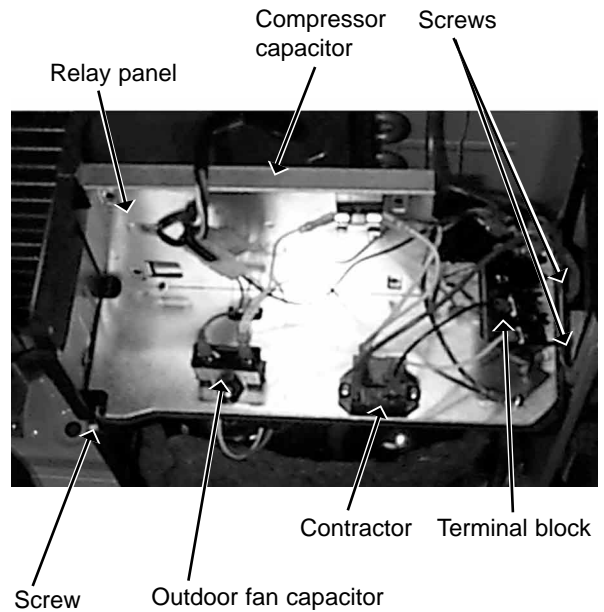

3. Removing the propeller and the outdoor fan motor

- (1) Remove the cabinet. (Refer to 1.)
 - (2) Remove the propeller nut.
 - (3) Remove the propeller.
- NOTE : Loose the propeller in the rotating direction for removal.**
- When attaching the propeller, align the mark on the propeller and the motor shaft cut section.
Set the propeller in position by using the cut on the shaft and the mark on the propeller.
- (4) Remove lead clamps and disconnect the outdoor fan motor connector.
 - (5) Remove screws fixing the fan motor.
 - (6) Remove the outdoor fan motor.

Photo 5

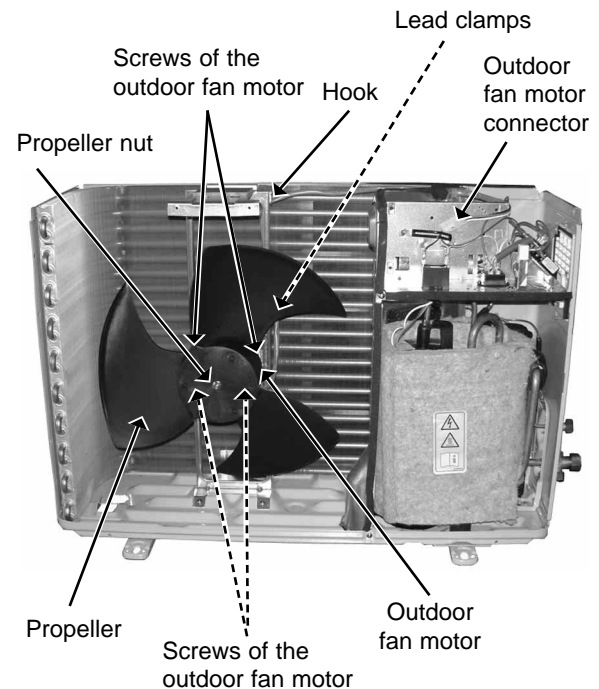



OPERATING PROCEDURE

4. Removing the compressor

- (1) Remove the cabinet. (Refer to 1.)
- (2) Remove the relay panel.
- (3) Remove the soundproof felt.
- (4) Remove the terminal cover on the compressor.
- (5) Disconnect lead wires from the glass terminal of the compressor.
- (6) Recover gas from the refrigerant circuit.
- (7) Disconnect the welded part of the discharge pipe.
- (8) Disconnect the welded part of the suction pipe.
- (9) Remove nuts fixing the compressor.
- (10) Remove the compressor.

NOTE

- Before using a burner, reclaim gas from the pipes until the pressure gauge shows 0 kg/cm² (0 MPa) .
- Use the burner under the condition that gas can be recovered even when the inner pressure rises by heat.

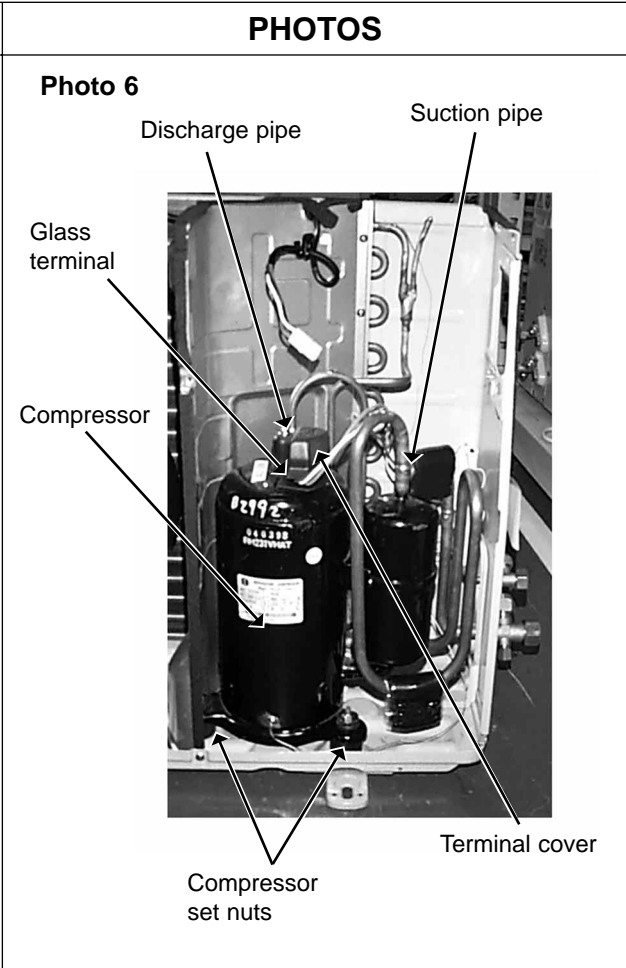

MU-A07YV -E1

MU-A09YV -E1

MU-A12YV -E1

11-1. OUTDOOR UNIT STRUCTURAL PARTS

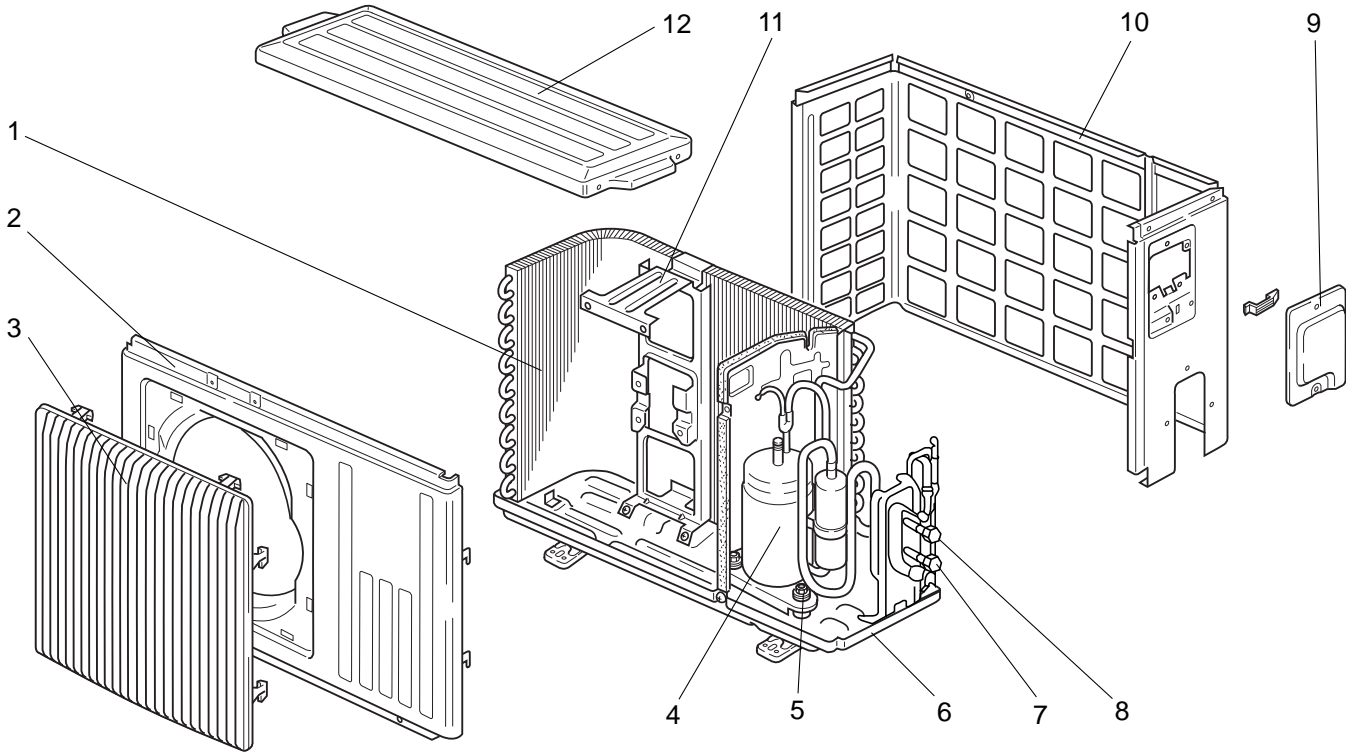

Part number that is circled is not shown in the illustration.

No.	Part No.	Part name	Symbol in Wiring Diagram	Q'ty/unit			Remarks
				MU-A07YV- E1	MU-A09YV- E1	MU-A12YV- E1	
1	E02 832 630	OUTDOOR HEAT EXCHANGER		1	1	1	
2	E02 815 232	CABINET		1	1	1	
3	E02 815 521	GRILLE(OUT)		1	1	1	
4	E02 742 900	COMPRESSOR	MC	1			RN092VHSHT
	E02 743 900	COMPRESSOR	MC		1		RN099VHSHT
	E02 754 900	COMPRESSOR	MC			1	RN135VHSHT
5	E02 075 506	COMPRESSOR RUBBER SET		3	3	3	3RUBBERS/SET
6	E02 832 290	BASE		1	1	1	
7	E02 742 661	STOP VALVE(GAS)		1	1		φ9.52
	E02 747 661	STOP VALVE(GAS)				1	φ12.7
8	E02 742 662	STOP VALVE(LIQUID)		1	1	1	φ6.35
9	E02 815 245	SERVICE PANEL		1	1	1	
10	E02 815 233	BACK PANEL		1	1		
	E02 835 233	BACK PANEL				1	
11	E02 336 515	MOTOR SUPPORT		1	1	1	
12	E02 815 297	TOP PANEL		1	1	1	
13	E02 459 936	CAPILLARY TUBE		1	1		φ3.0xφ1.4x900
	E02 441 936	CAPILLARY TUBE				1	φ3.0xφ1.4x550

MU-A07YV -E1 MU-A09YV -E1 MU-A12YV -E1

11-2. OUTDOOR UNIT ELECTRICAL PARTS AND FUNCTIONAL PARTS

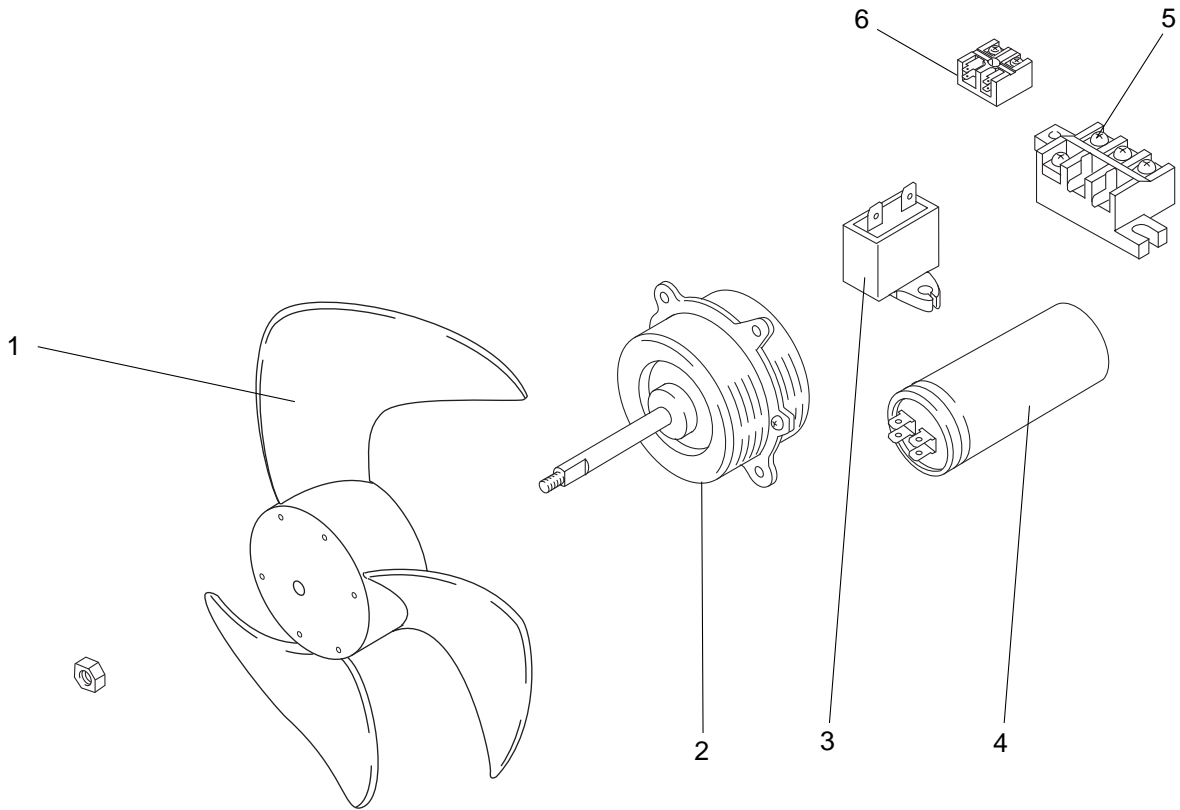

Part numbers that are circled are not shown in the illustration.

No.	Part No.	Part name	Symbol in Wiring Diagram	Q'ty/unit			Remarks
				MU-A07YV- E1	MU-A09YV- E1	MU-A12YV- E1	
1	E02 665 501	PROPELLER		1	1	1	
2	E02 832 301	OUTDOOR FAN MOTOR	MF	1	1		RC6V20-□□
	E02 677 301	OUTDOOR FAN MOTOR	MF			1	RA6V33-□□
3	E02 661 351	OUTDOOR FAN CAPACITOR	C2	1	1		1.5 μ F /440V AC
	E02 664 351	OUTDOOR FAN CAPACITOR	C2			1	2.0 μ F /440V AC
4	E02 752 353	COMPRESSOR CAPACITOR	C1	1			20 μ F /440V AC
	E02 694 353	COMPRESSOR CAPACITOR	C1		1		25 μ F /440V AC
	E02 696 353	COMPRESSOR CAPACITOR	C1			1	30 μ F /440V AC
5	E02 817 374	TERMINAL BLOCK	TB1	1	1	1	3P
6	E02 832 374	TERMINAL BLOCK	TB2	1	1	1	2P
⑦	E02 466 340	COMPRESSOR CONTACTOR	52C	1	1	1	
⑧	E02 128 383	SURGE ABSORBER	DSAR	1	1	1	



HEAD OFFICE: MITSUBISHI DENKI BLDG.,2-2-3, MARUNOUCHI, CHIYODA-KU, TOKYO100-8310, JAPAN

© Copyright 2003 MITSUBISHI ELECTRIC ENGINEERING CO.,LTD
Distributed in Mar. 2004. No.OB330 REVISED EDITION-A 6
Distributed in Dec. 2003. No.OB330 6
Made in Japan

New publication, effective Mar. 2004
Specifications subject to change without notice.