

Revision A:

- MUH-A12YV -[E1] can be connected to MCFH-A12WV -[E1].

Please void OB331.

SERVICE MANUAL

**No. OB331
REVISED EDITION-A**
**Wireless type
Models**
MUH-A07YV -[E1]

MUH-A09YV -[E1]

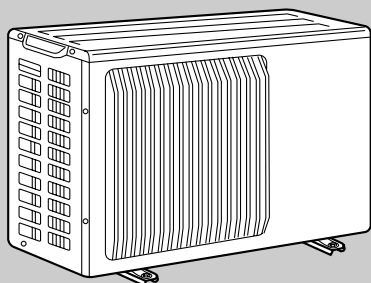
MUH-A12YV -[E1]

 Indication of
model name

MUH-A07YV -[E1]

MUH-A09YV -[E1]

MUH-A12YV -[E1]

CONTENTS

1. TECHNICAL CHANGES	2
2. PART NAMES AND FUNCTIONS.....	5
3. SPECIFICATION.....	5
4. NOISE CRITERIA CURVES	6
5. OUTLINES AND DIMENSIONS	7
6. WIRING DIAGRAM	7
7. REFRIGERANT SYSTEM DIAGRAM	8
8. PERFORMANCE CURVES.....	9
9. MICROPROCESSOR CONTROL	22
10. SERVICE FUNCTIONS.....	24
11. TROUBLESHOOTING	24
12. DISASSEMBLY INSTRUCTIONS.....	31
13. PARTS LIST.....	34

NOTE:

- This manual describes technical data of outdoor units.
- As for indoor units MSC-A07/A09/A12YV -[E1], refer to the service manual OB329.
- As for indoor unit MCFH-A12WV -[E1], refer to the service manual OB336.



Revision A:

- MUH-A12YV -[E1] can be connected to MCFH-A12WV -[E1].
SPECIFICATION, PERFORMANCE CURVES and TROUBLESHOOTING have been added.

1 TECHNICAL CHANGES

MUH-A07WV-[E1] → MUH-A07YV-[E1]

1. Outdoor heat exchanger has changed.
2. Outdoor fan motor has changed. (RA6V23-FB → RC6V20-AB)

MUH-A09WV-[E1] → MUH-A09YV-[E1]**MUH-A12WV-[E1] → MUH-A12YV-[E1]**

1. Outdoor heat exchanger has changed.
2. Outdoor fan motor has changed. (RA6V33-DB → RA6V33-FB)

INFORMATION FOR THE AIR CONDITIONER WITH R410A REFRIGERANT

- This room air conditioner adopts an HFC refrigerant (R410A) which never destroys the ozone layer.
- Pay particular attention to the following points, though the basic installation procedure is same as that for R22 conditioners.
 - ① As R410A has working pressure approximate 1.6 times as high as that of R22, some special tools and piping parts/materials are required. Refer to the table below.
 - ② Take sufficient care not to allow water and other contaminations to enter the R410A refrigerant during storage and installation, since it is more susceptible to contaminations than R22.
 - ③ For refrigerant piping, use clean, pressure-proof parts/materials specifically designed for R410A. (Refer to 2. Refrigerant piping.)
 - ④ Composition change may occur in R410A since it is a mixed refrigerant. When charging, charge liquid refrigerant to prevent composition change.

		New refrigerant	Previous refrigerant
Refrigerant	Refrigerant	R410A	R22
	Composition (Ratio)	HFC-32: HFC-125 (50%:50%)	R22 (100%)
	Refrigerant handling	Pseudo-azeotropic refrigerant	Single refrigerant
	Chlorine	Not included	Included
	Safety group (ASHRAE)	A1/A1	A1
	Molecular weight	72.6	86.5
	Boiling point (°C)	-51.4	-40.8
	Steam pressure [25°C](Mpa)	1.557	0.94
	Saturated steam density [25°C](Kg/m³)	64	44.4
	Combustibility	Non combustible	Non combustible
	ODP ※1	0	0.055
	GWP ※2	1730	1700
	Refrigerant charge method	From liquid phase in cylinder	Gas phase
	Additional charge on leakage	Possible	Possible
Refrigerating oil	Kind	Incompatible oil	Compatible oil
	Color	Non	Light yellow
	Smell	Non	Non

※1 :Ozone Destruction Parameter : based on CFC-11

※2 :Global Warmth Parameter : based on CO₂

	New Specification	Current Specification
Compressor	<p>The incompatible refrigerating oil easily separates from refrigerant and is in the upper layer inside the suction muffler. Raising position of the oil back hole enables to back the refrigerating oil of the upper layer to flow back to the compressor.</p>	<p>Since refrigerant and refrigerating oil are compatible each, refrigerating oil backs to the compressor through the lower position oil back hole.</p>

NOTE : The unit of pressure has been changed to MPa on the international system of units(SI unit system).
The conversion factor is: **1(MPa [Gauge]) =10.2(kgf/cm² [Gauge])**

Conversion chart of refrigerant temperature and pressure

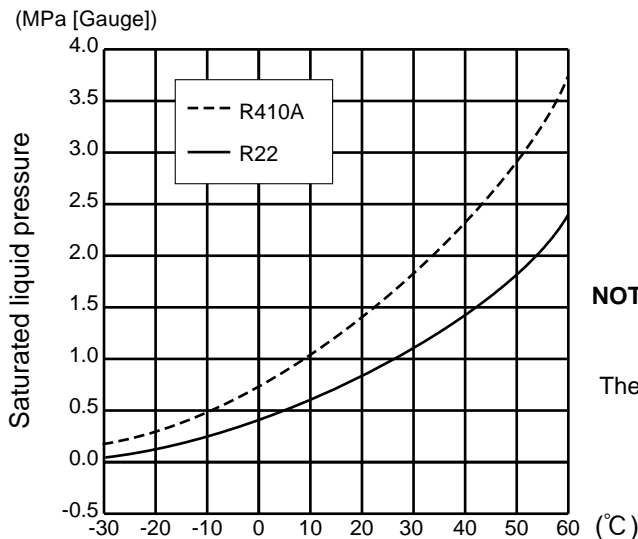

NOTE : The unit of pressure has been changed to MPa on the international system of units(SI unit system).
The conversion factor is: **1(MPa [Gauge]) =10.2(kgf/cm² [Gauge])**

1.Tools dedicated for the air conditioner with R410A refrigerant

The following tools are required for R410A refrigerant. Some R22 tools can be substituted for R410A tools. The diameter of the service port on the stop valve in outdoor unit has been changed to prevent any other refrigerant being charged into the unit. Cap size has been changed from 7/16 UNF with 20 threads to 1/2 UNF with 20 threads.

R410A tools	Can R22 tools be used?	Description
Gauge manifold	No	R410A has high pressures beyond the measurement range of existing gauges. Port diameters have been changed to prevent any other refrigerant from being charged into the unit.
Charge hose	No	Hose material and cap size have been changed to improve the pressure resistance.
Gas leak detector	No	Dedicated for HFC refrigerant.
Torque wrench	Yes	6.35 mm and 9.52 mm
	No	12.7 mm
Flare tool	Yes	Clamp bar hole has been enlarged to reinforce the spring strength in the tool.
Flare gauge	New	Provided for flaring work (to be used with R22 flare tool).
Vacuum pump adapter	New	Provided to prevent the back flow of oil. This adapter enables you to use vacuum pumps.
Electronic scale for refrigerant charging	New	It is difficult to measure R410A with a charging cylinder because the refrigerant bubbles due to high pressure and high-speed vaporization

No : Not Substitutable for R410A Yes : Substitutable for R410A

2.Refrigerant piping

① Specifications

Use the refrigerant pipes that meet the following specifications.

Pipe	Outside diameter	Wall thickness	Insulation material
	mm		
For liquid	6.35	0.8 mm	Heat resisting foam plastic Specific gravity 0.045 Thickness 8 mm
For gas	9.52	0.8 mm	
	12.7	0.8 mm	

- Use a copper pipe or a copper-alloy seamless pipe with a thickness of 0.8 mm. Never use any pipe with a thickness less than 0.8mm, as the pressure resistance is insufficient.

② Flaring work and flare nut

Flaring work for R410A pipe differs from that for R22 pipe.

For details of flaring work, refer to Installation manual "FLARING WORK".

Pipe diameter	Dimension of flare nut	
	R410A	R22
mm		
6.35	17	17
9.52	22	22
12.7	26	24

3.Refrigerant oil

Apply the special refrigeration oil (accessories: packed with indoor unit) to the flare and the union seat surfaces.

4.Air purge

- Do not discharge the refrigerant into the atmosphere.
Take care not to discharge refrigerant into the atmosphere during installation, reinstallation, or repairs to the refrigerant circuit.
- Use the vacuum pump for air purging for the purpose of environmental protection.

5.Additional charge

For additional charging, charge the refrigerant from liquid phase of the gas cylinder.

If the refrigerant is charged from the gas phase, composition change may occur in the refrigerant inside the cylinder and the outdoor unit. In this case, ability of the refrigerating cycle decreases or normal operation can be impossible. However, charging the liquid refrigerant all at once may cause the compressor to be locked. Thus, charge the refrigerant slowly.

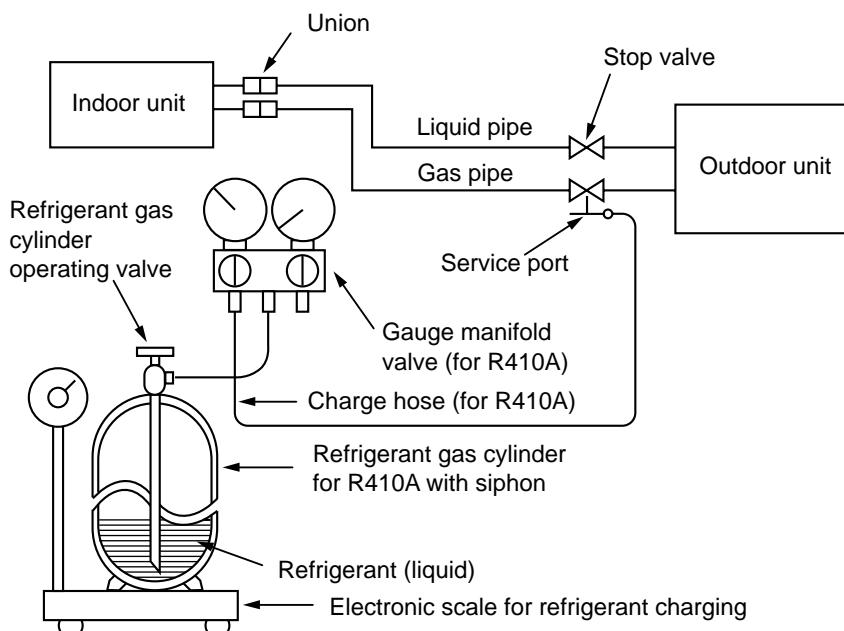

2

PART NAMES AND FUNCTIONS

OUTDOOR UNIT

MUH-A07YV -^[E1]

MUH-A09YV -^[E1]

MUH-A12YV -^[E1]

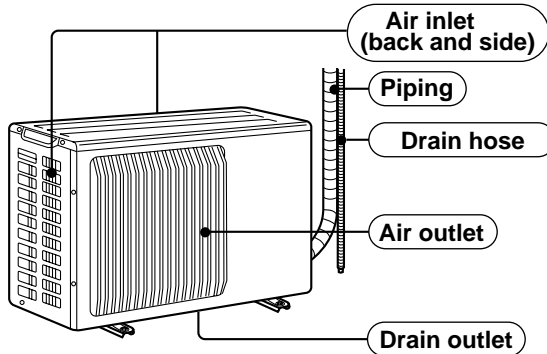

ACCESSORIES

MUH-A07YV-^[E1]

MUH-A09YV-^[E1]

MUH-A12YV-^[E1]

<Outdoor unit: MUH type>

①	Drain socket	1
②	Drain cap	2

3

SPECIFICATION

Outdoor model			MUH-A07YV - ^[E1]		MUH-A09YV - ^[E1]		MUH-A12YV - ^[E1] Indoor model MSC-A12YV - ^[E1]		MUH-A12YV - ^[E1] Indoor model MCFH-A12WV - ^[E1]	
Outdoor unit power supply			Single phase 230V,50Hz		Single phase 230V,50Hz		Single phase 230V,50Hz		Single phase 230V,50Hz	
Function			Cooling	Heating	Cooling	Heating	Cooling	Heating	Cooling	Heating
Capacity	Capacity	kW	2.3	2.5	2.55	3.05	3.5	3.9	3.5	3.7
	Dehumidification	ℓ /h	0.9	—	1.1	—	1.7	—	1.5	—
	Outdoor air flow	m ³ /h	1,686		1,710		1,710		1,710	
Electrical data	Power outlet	A	10		10		10		10	
	Running current	A	3.00	2.86	3.32	3.52	4.65	4.60	4.85	4.23
	Power input	W	680	655	760	805	1,050	1,040	1,094	954
	Auxiliary heater	A(kW)	—		—		—		—	
	Power factor	%	98	99	99	99	98	98	98	98
	Starting current	A	23		24		29		29	
	Compressor motor current	A	2.78	2.64	3.01	3.21	4.34	4.29	4.54	3.92
	Fan motor current	A	0.22		0.31		0.31		0.31	
Coefficient of performance (C.O.P)			3.22	3.62	3.21	3.69	3.21	3.61	3.02	3.63
Compressor	Model		RN092VHSHT		RN104VHSHT		RN135VHSHT		RN135VHSHT	
	Output	W	600		700		900		900	
	Winding resistance (at 20°C)	Ω	C-R 3.87 C-S 6.14		C-R 3.40 C-S 4.56		C-R 2.79 C-S 3.36		C-R 2.79 C-S 3.36	
	Fan motor		RC6V20-AB		RA6V33-FB		RA6V33-FB		RA6V33-FB	
Fan motor	Winding resistance (at 20°C)	Ω	WHT-BLK 410 BLK-RED 433		WHT-BLK 223 BLK-RED 228		WHT-BLK 223 BLK-RED 228		WHT-BLK 223 BLK-RED 228	
	Dimensions W×H×D	mm	780×540×255		780×540×255		780×540×255		780×540×255	
	Weight	kg	35		38		40		40	
Special remarks	Sound level	dB	47		49		49		49	
	Fan speed	rpm	735		825		825		825	
	Fan speed regulator		1		1		1		1	
	Refrigerant filling capacity (R410A)	kg	0.62		1.00		1.00		1.00	
	Refrigerating oil (Model)	cc	350 (NEO22)		350 (NEO22)		620 (NEO22)		620 (NEO22)	
	Thermistor RT61 (at 0°C)	kΩ	33.18		33.18		33.18		33.18	

NOTE: Test conditions are based on ISO 5151.

Cooling : Indoor DB27°C WB19°C

Outdoor DB35°C WB24°C

Indoor-Outdoor piping length : 5m

Heating : Indoor DB20°C

Outdoor DB 7°C/WB 6°C

NOISE CRITERIA CURVES

MUH-A07YV- E1

FUNCTION	SPL(dB(A))	LINE
COOL	47	●—●
HEAT		

Test conditions,
Cooling :DB35°C WB24°C
Heating :DB 7°C WB 6°C

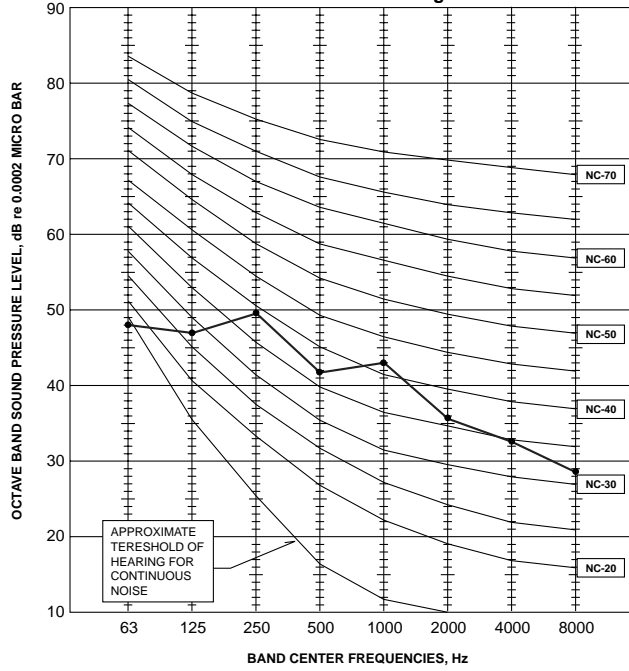

MUH-A09YV- E1
MUH-A12YV- E1

FUNCTION	SPL(dB(A))	LINE
COOL	49	●—●
HEAT		

Test conditions,
Cooling :DB35°C WB24°C
Heating :DB 7°C WB 6°C

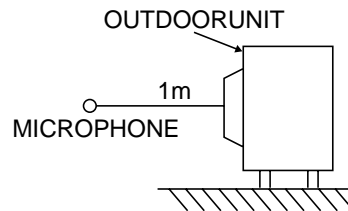
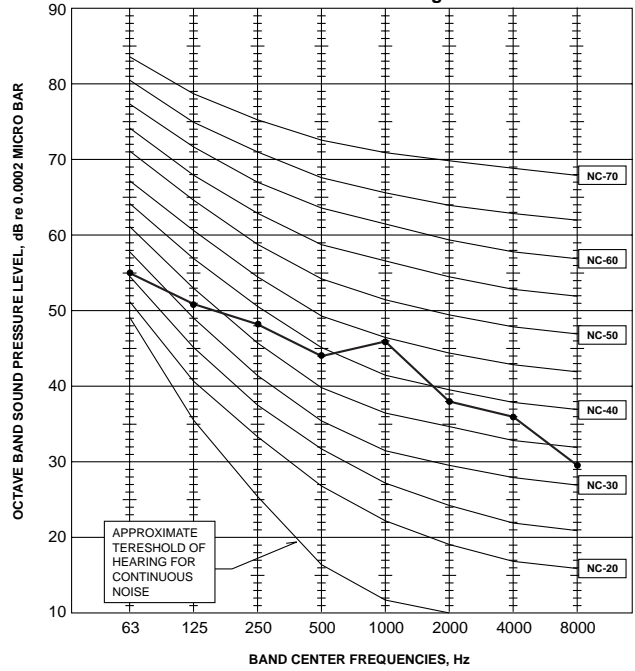

5

OUTLINES AND DIMENSIONS

MUH-A07YV -E1 MUH-A09YV -E1 MUH-A12YV -E1

Unit: mm

OUTDOOR UNIT

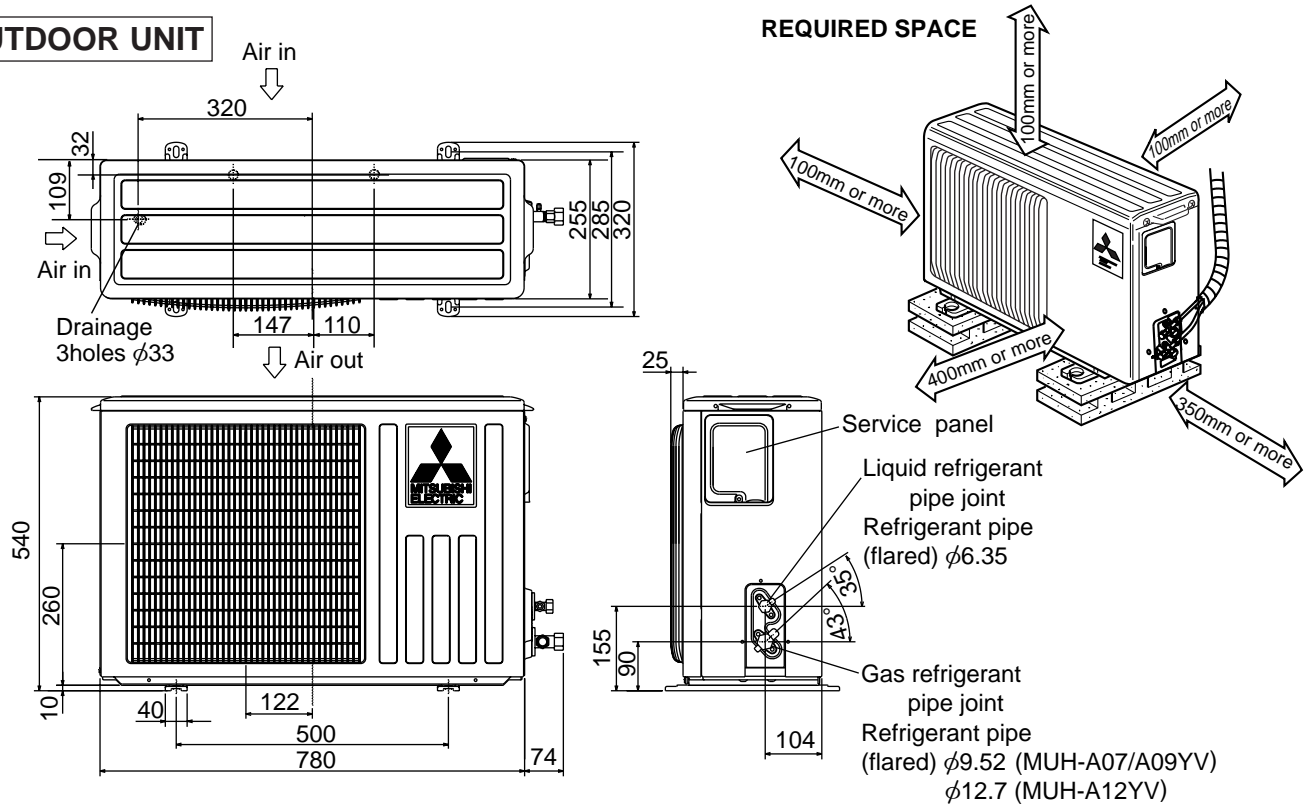

6

WIRING DIAGRAM

MUH-A07YV -E1
 MUH-A09YV -E1
 MUH-A12YV -E1

MODELS WIRING DIAGRAM

OUTDOOR UNIT

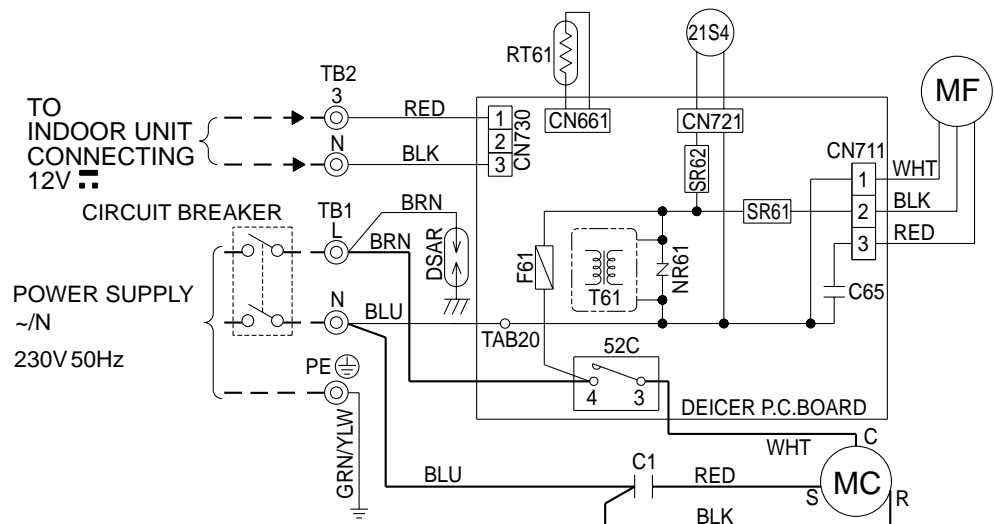

SYMBOL	NAME	SYMBOL	NAME	SYMBOL	NAME
C1	COMPRESSOR CAPACITOR	MF	OUTDOOR FAN MOTOR (INNER FUSE/INNER PROTECTOR)	T61	TRANS FORMER
C65	OUTDOOR FAN CAPACITOR			TB1, TB2	TERMINAL BLOCK
DSAR	SURGE ABSORBER	NR61	VARISTOR	21S4	R.V. COIL
F61	FUSE(2A)	RT61	DEFROST THERMISTOR	52C	COMPRESSOR CONTACTOR
MC	COMPRESSOR(INNER PROTECTOR)	SR61, SR62	SOLID STATE RELAY		

NOTE:1. About the indoor side electric wiring refer to the indoor unit electric wiring diagram for servicing.

2. Use copper conductors only. (For field wiring)

3. Symbols below indicate.

⊙: Terminal block, □□□: Connector

MUH-A07YV -E1

MUH-A09YV -E1

Unit:mm

OUTDOOR UNIT

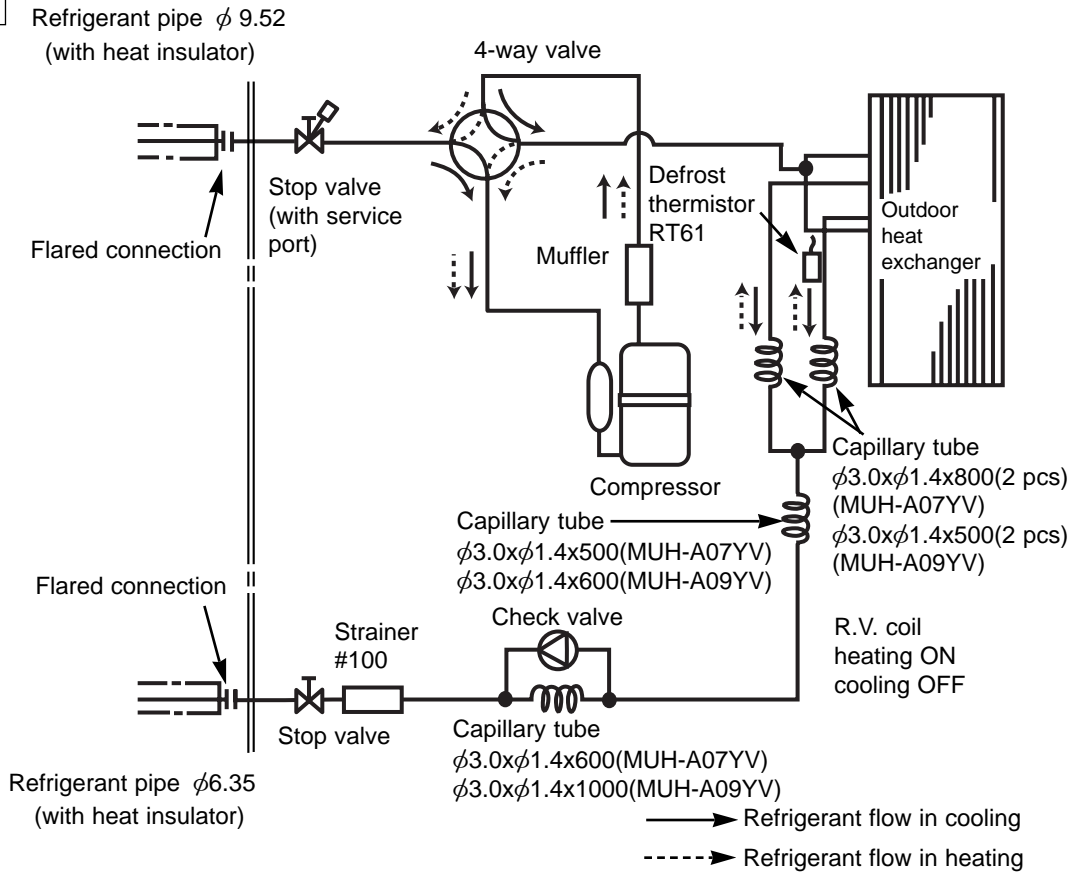

MUH-A12YV -E1

Unit:mm

OUTDOOR UNIT

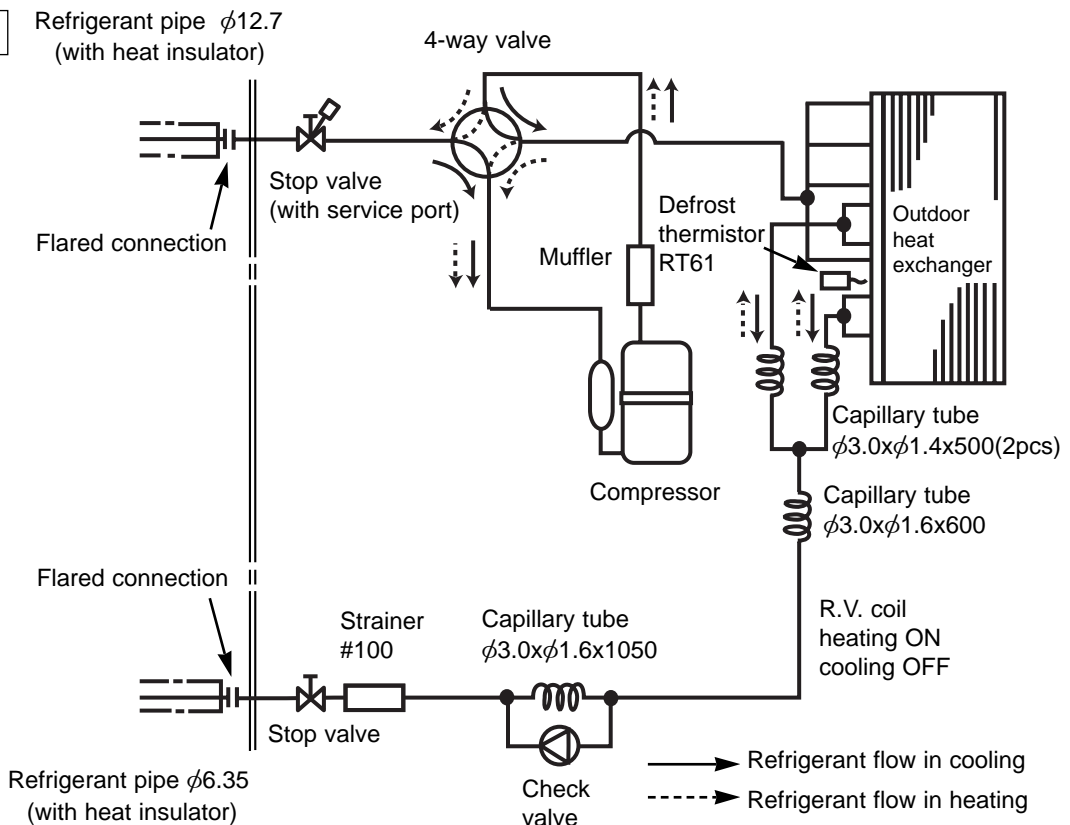

MAX. REFRIGERANT PIPING LENGTH

Model	Refrigerant piping Max. length : m A	Piping size O.D : mm		Length of connecting pipe : m	
		Gas	Liquid	Indoor unit	Outdoor unit
MUH-A07YV - E1 MUH-A09YV - E1	20	9.52	6.35	Gas 0.43	Gas 0
MUH-A12YV - E1	25	12.7		Liquid 0.5	Liquid 0

MAX. HEIGHT DIFFERENCE

Height difference should be within 10m regardless of which unit, indoor or outdoor position is high.

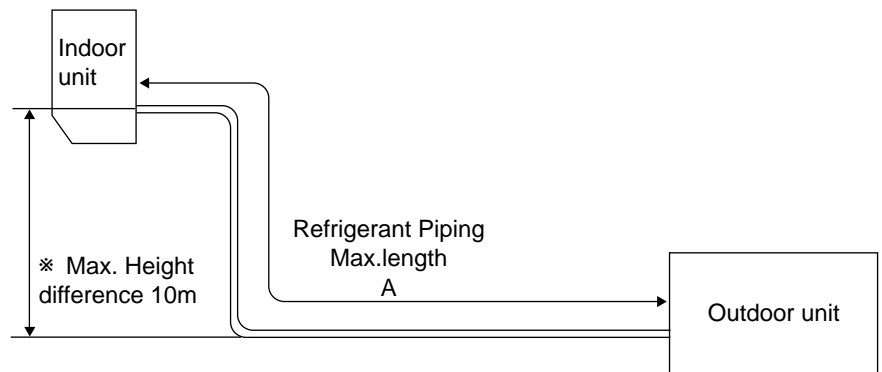

ADDITIONAL REFRIGERANT CHARGE(R410A : g)

Model	Outdoor unit precharged	Refrigerant piping length (one way)				
		7m	10m	15m	20m	25m
MUH-A07YV - E1	620					/
MUH-A09YV - E1 MUH-A12YV - E1	1000	0	60	160	260	

Calculation : $Xg=20g/m \times 5 \times (A-7)m$

8

PERFORMANCE CURVES

MUH-A07YV -E1 MUH-A09YV -E1 MUH-A12YV -E1

The standard data contained in these specifications apply only to the operation of the air conditioner under normal conditions, since operating conditions vary according to the areas where these units are installed. The following information has been provided to clarify the operating characteristics of the air conditioner under the conditions indicated by the performance curve.

(1) GUARANTEED VOLTAGE

198~264V

(2) AIR FLOW

Air flow should be set at MAX.

(3) MAIN READINGS

- | | | | | |
|-----------------------------------------------|------|---|--|--|
| (1) Indoor intake air wet-bulb temperature : | °CWB | } | | |
| (2) Indoor outlet air wet-bulb temperature : | °CWB | | | |
| (3) Outdoor intake air dry-bulb temperature : | °CDB | | | |
| (4) Total input: | W | | | |
| (5) Indoor intake air dry-bulb temperature : | °CDB | } | | |
| (6) Outdoor intake air wet-bulb temperature : | °CWB | | | |
| (7) Total input : | W | | | |

Indoor air wet/dry-bulb temperature difference on the left side of the chart on page 10 shows the difference between the indoor intake air wet/dry-bulb temperature and the indoor outlet air wet/dry-bulb temperature for your reference at service.

How to measure the indoor air wet-bulb/dry-bulb temperature difference

1. Attach at least 2 sets of wet-and dry-bulb thermometers to the indoor air intake as shown in the figure, and at least 2 sets of wet-and dry-bulb thermometers to the indoor air outlet. The thermometers must be attached to the position where air speed is high.
2. Attach at least 2 sets of wet-and dry-bulb thermometers to the outdoor air intake. Cover the thermometers to prevent direct rays of the sun.
3. Check that the air filter is cleaned.
4. Open windows and doors of room.
5. Press the EMERGENCY OPERATION switch once(twice) to start the EMERGENCY COOL (HEAT) MODE.
6. When system stabilizes after more than 15 minutes, measure temperature and take an average temperature.
7. 10 minutes later, measure temperature again and check that the temperature does not change.

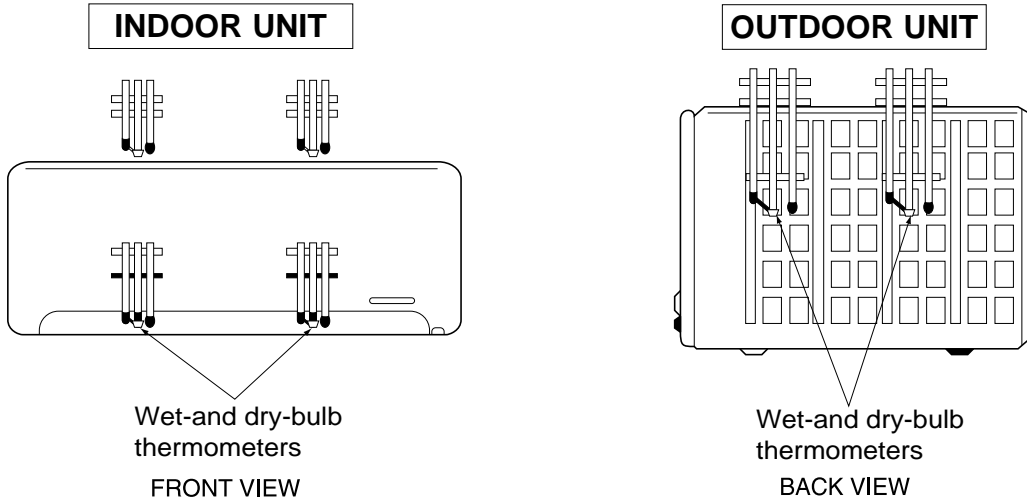

8-1.CAPACITY AND THE INPUT CURVES

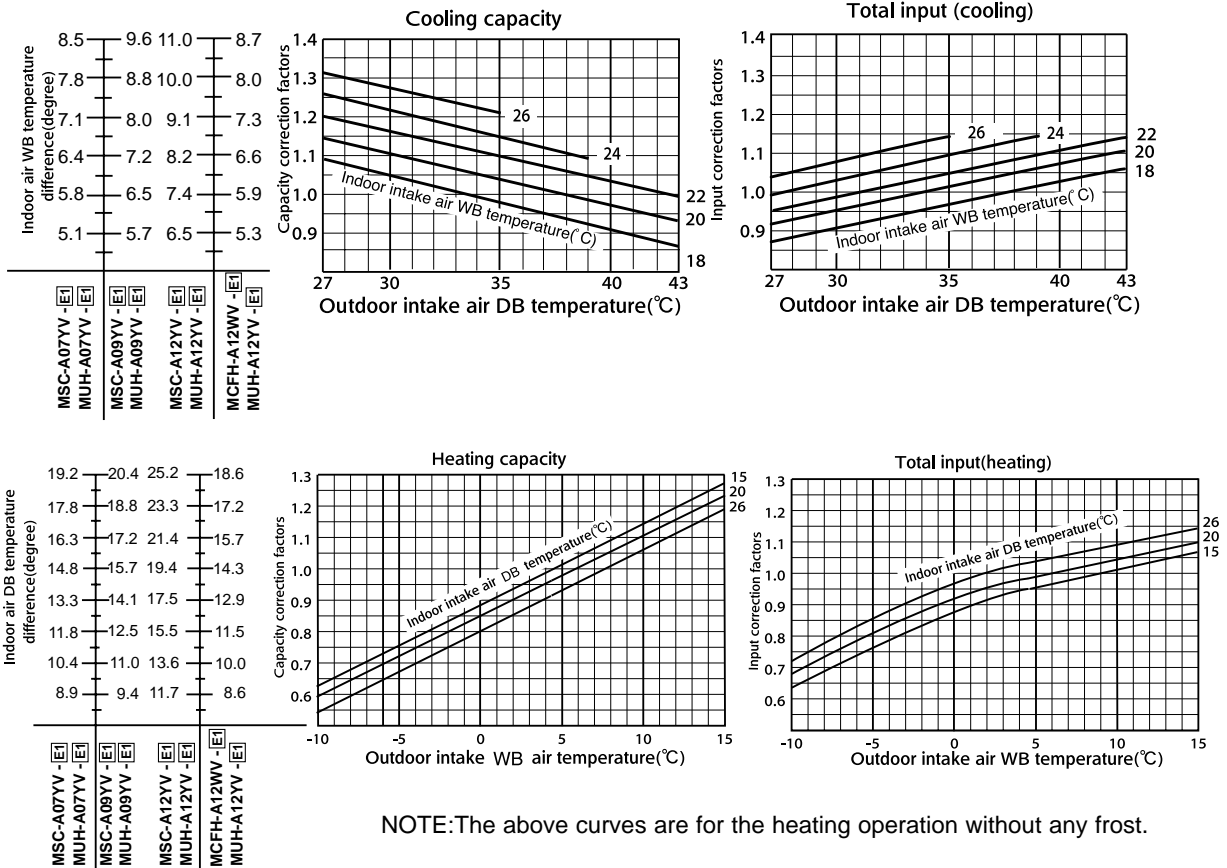

8-2. OUTDOOR LOW PRESSURE AND OUTDOOR UNIT CURRENT COOL operation

① Both indoor and outdoor unit are under the same temperature/humidity condition.

Dry-bulb temperature	Relative humidity(%)
20	50
25	60
30	70

② Air flow should be set at MAX.

③ The unit of pressure has been changed to MPa on the international system of units(SI unit system).

The conversion factor is : **1(MPa[Gauge]) = 10.2(kgf/cm²[Gauge])**

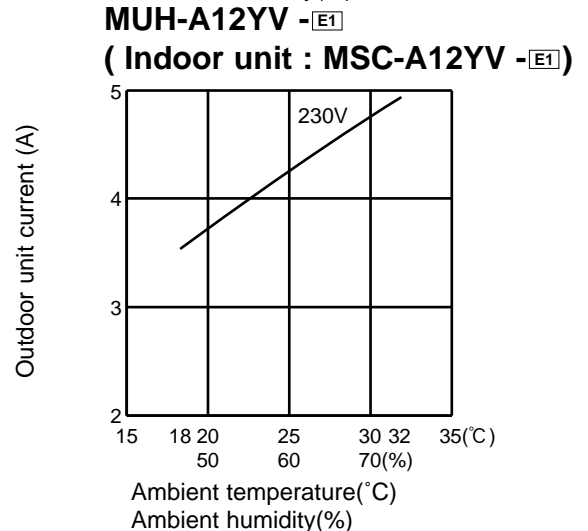
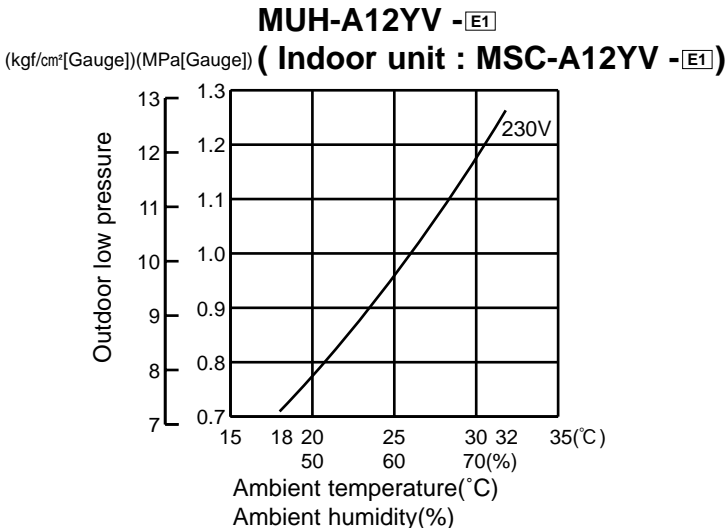
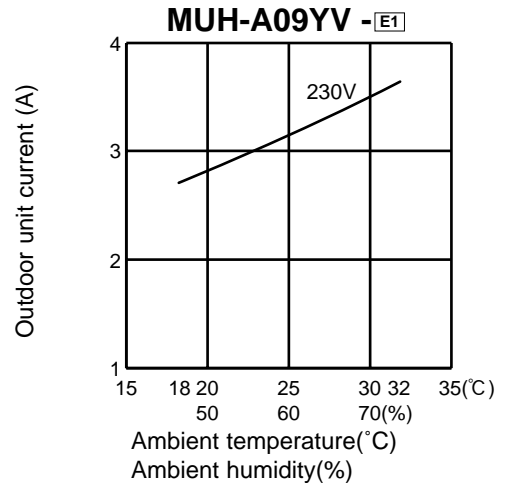
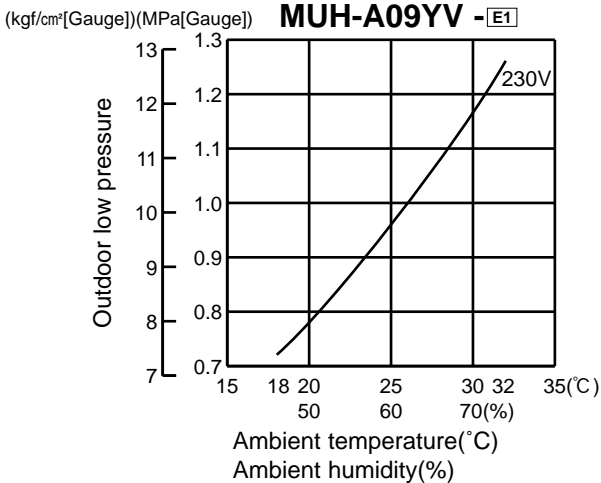
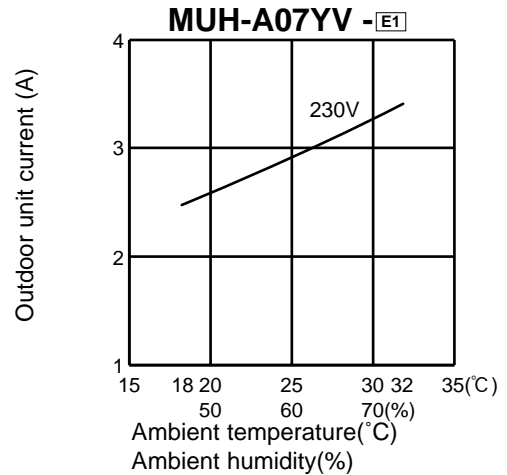
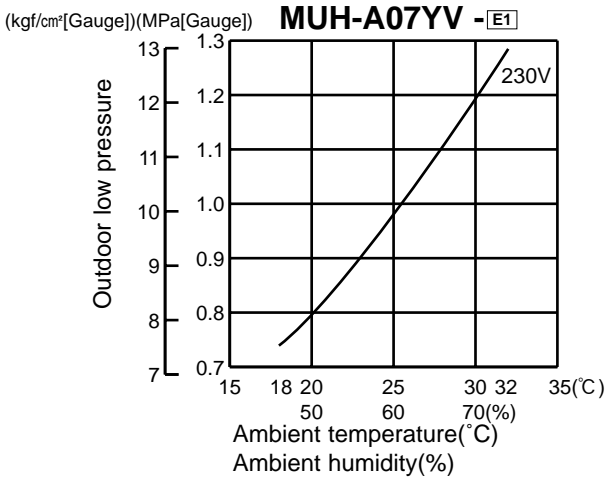



MUH-A12YV -[E1]

(kgf/cm²[Gauge])(MPa[Gauge])

(Indoor unit : MCFH-A12WV -[E1])

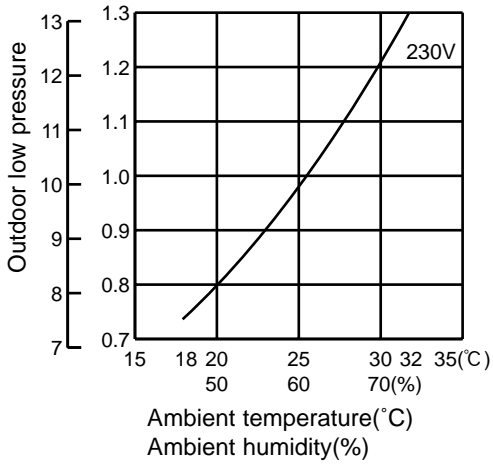

MUH-A12YV -[E1]

(Indoor unit : MCFH-A12WV -[E1])

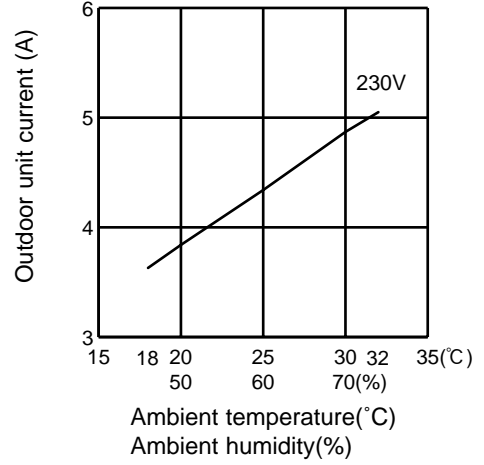

HEAT operation

Condition indoor: Dry bulb temperature 20.0°C
Wet bulb temperature 14.5°C

Outdoor: Dry bulb temperature 7, 15, 20°C
Wet bulb temperature 6, 12, 14.5°C

MUH-A07YV -[E1]

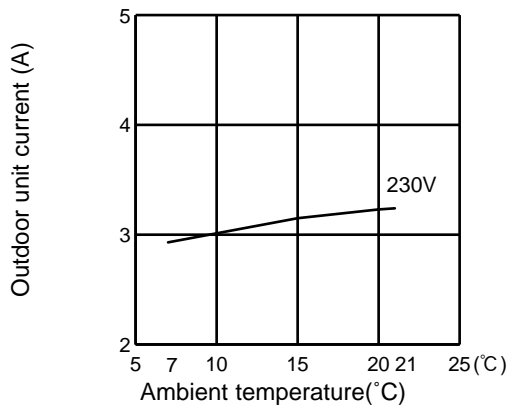

MUH-A09YV -[E1]

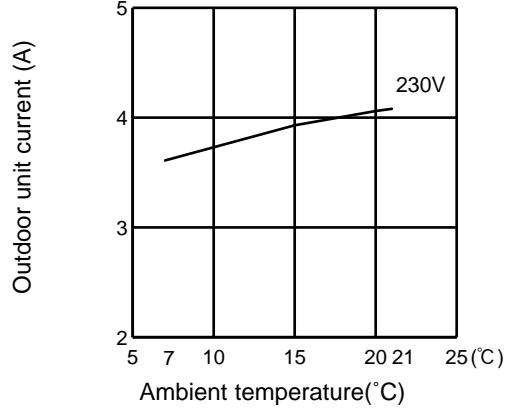

MUH-A12YV -[E1]

(Indoor unit : MSC-A12YV -[E1])

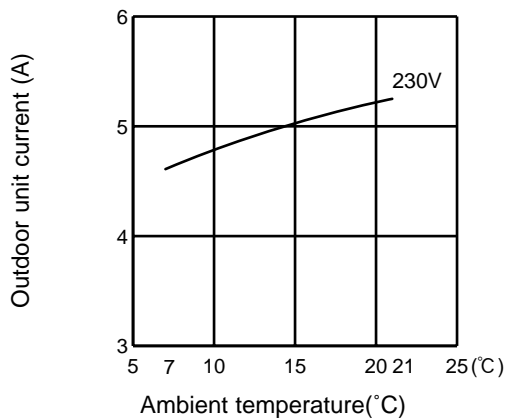

MUH-A12YV -[E1]

(Indoor unit : MCFH-A12WV -[E1])

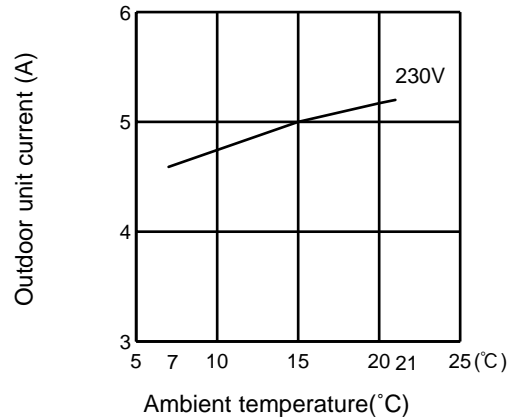

PERFORMANCE DATA

COOL operation (230V)

MSC-A07YV -[E1] : MUH-A07YV -[E1]

CAPACITY : 2.3(KW) SHF : 0.74 INPUT : 715(W)

		OUTDOOR DB(°C)															
INDOOR DB(°C)	INDOOR WB(°C)	21				25				27				30			
		Q	SHC	SHF	INPUT	Q	SHC	SHF	INPUT	Q	SHC	SHF	INPUT	Q	SHC	SHF	INPUT
21	18	2.70	1.51	0.56	572	2.59	1.45	0.56	601	2.48	1.39	0.56	629	2.39	1.34	0.56	658
21	20	2.82	1.24	0.44	601	2.70	1.19	0.44	636	2.62	1.15	0.44	651	2.53	1.11	0.44	679
22	18	2.70	1.62	0.60	572	2.59	1.55	0.60	601	2.48	1.49	0.60	629	2.39	1.44	0.60	658
22	20	2.82	1.35	0.48	601	2.70	1.30	0.48	636	2.62	1.26	0.48	651	2.53	1.21	0.48	679
22	22	2.93	1.06	0.36	622	2.83	1.02	0.36	661	2.76	0.99	0.36	679	2.65	0.95	0.36	708
23	18	2.70	1.73	0.64	572	2.59	1.66	0.64	601	2.48	1.59	0.64	629	2.39	1.53	0.64	658
23	20	2.82	1.47	0.52	601	2.70	1.41	0.52	636	2.62	1.36	0.52	651	2.53	1.32	0.52	679
23	22	2.93	1.17	0.40	622	2.83	1.13	0.40	661	2.76	1.10	0.40	679	2.65	1.06	0.40	708
24	18	2.70	1.84	0.68	572	2.59	1.76	0.68	601	2.48	1.69	0.68	629	2.39	1.63	0.68	658
24	20	2.82	1.58	0.56	601	2.70	1.51	0.56	636	2.62	1.47	0.56	651	2.53	1.42	0.56	679
24	22	2.93	1.29	0.44	622	2.83	1.24	0.44	661	2.76	1.21	0.44	679	2.65	1.16	0.44	708
24	24	3.08	0.99	0.32	651	2.97	0.95	0.32	686	2.90	0.93	0.32	708	2.81	0.90	0.32	744
25	18	2.70	1.95	0.72	572	2.59	1.86	0.72	601	2.48	1.79	0.72	629	2.39	1.72	0.72	658
25	20	2.82	1.69	0.60	601	2.70	1.62	0.60	636	2.62	1.57	0.60	651	2.53	1.52	0.60	679
25	22	2.93	1.41	0.48	622	2.83	1.36	0.48	661	2.76	1.32	0.48	679	2.65	1.27	0.48	708
25	24	3.08	1.11	0.36	651	2.97	1.07	0.36	686	2.90	1.04	0.36	708	2.81	1.01	0.36	744
26	18	2.70	2.05	0.76	572	2.59	1.97	0.76	601	2.48	1.89	0.76	629	2.39	1.82	0.76	658
26	20	2.82	1.80	0.64	601	2.70	1.73	0.64	636	2.62	1.68	0.64	651	2.53	1.62	0.64	679
26	22	2.93	1.52	0.52	622	2.83	1.47	0.52	661	2.76	1.44	0.52	679	2.65	1.38	0.52	708
26	24	3.08	1.23	0.40	651	2.97	1.19	0.40	686	2.90	1.16	0.40	708	2.81	1.12	0.40	744
26	26	3.17	0.89	0.28	686	3.08	0.86	0.28	722	3.04	0.85	0.28	744	2.94	0.82	0.28	765
27	18	2.70	2.16	0.80	572	2.59	2.07	0.80	601	2.48	1.99	0.80	629	2.39	1.91	0.80	658
27	20	2.82	1.92	0.68	601	2.70	1.84	0.68	636	2.62	1.78	0.68	651	2.53	1.72	0.68	679
27	22	2.93	1.64	0.56	622	2.83	1.58	0.56	661	2.76	1.55	0.56	679	2.65	1.48	0.56	708
27	24	3.08	1.36	0.44	651	2.97	1.31	0.44	686	2.90	1.28	0.44	708	2.81	1.23	0.44	744
27	26	3.17	1.02	0.32	686	3.08	0.99	0.32	722	3.04	0.97	0.32	744	2.94	0.94	0.32	765
28	18	2.70	2.27	0.84	572	2.59	2.17	0.84	601	2.48	2.09	0.84	629	2.39	2.01	0.84	658
28	20	2.82	2.03	0.72	601	2.70	1.95	0.72	636	2.62	1.89	0.72	651	2.53	1.82	0.72	679
28	22	2.93	1.76	0.60	622	2.83	1.70	0.60	661	2.76	1.66	0.60	679	2.65	1.59	0.60	708
28	24	3.08	1.48	0.48	651	2.97	1.42	0.48	686	2.90	1.39	0.48	708	2.81	1.35	0.48	744
28	26	3.17	1.14	0.36	686	3.08	1.11	0.36	722	3.04	1.09	0.36	744	2.94	1.06	0.36	765
29	18	2.70	2.38	0.88	572	2.59	2.28	0.88	601	2.48	2.19	0.88	629	2.39	2.10	0.88	658
29	20	2.82	2.14	0.76	601	2.70	2.05	0.76	636	2.62	1.99	0.76	651	2.53	1.92	0.76	679
29	22	2.93	1.88	0.64	622	2.83	1.81	0.64	661	2.76	1.77	0.64	679	2.65	1.69	0.64	708
29	24	3.08	1.60	0.52	651	2.97	1.54	0.52	686	2.90	1.51	0.52	708	2.81	1.46	0.52	744
29	26	3.17	1.27	0.40	686	3.08	1.23	0.40	722	3.04	1.21	0.40	744	2.94	1.18	0.40	765
30	18	2.70	2.49	0.92	572	2.59	2.38	0.92	601	2.48	2.29	0.92	629	2.39	2.20	0.92	658
30	20	2.82	2.25	0.80	601	2.70	2.16	0.80	636	2.62	2.10	0.80	651	2.53	2.02	0.80	679
30	22	2.93	1.99	0.68	622	2.83	1.92	0.68	661	2.76	1.88	0.68	679	2.65	1.80	0.68	708
30	24	3.08	1.73	0.56	651	2.97	1.66	0.56	686	2.90	1.62	0.56	708	2.81	1.57	0.56	744
30	26	3.17	1.40	0.44	686	3.08	1.36	0.44	722	3.04	1.34	0.44	744	2.94	1.30	0.44	765
31	18	2.70	2.59	0.96	572	2.59	2.48	0.96	601	2.48	2.38	0.96	629	2.39	2.30	0.96	658
31	20	2.82	2.37	0.84	601	2.70	2.27	0.84	636	2.62	2.20	0.84	651	2.53	2.13	0.84	679
31	22	2.93	2.11	0.72	622	2.83	2.04	0.72	661	2.76	1.99	0.72	679	2.65	1.90	0.72	708
31	24	3.08	1.85	0.60	651	2.97	1.78	0.60	686	2.90	1.74	0.60	708	2.81	1.68	0.60	744
31	26	3.17	1.52	0.48	686	3.08	1.48	0.48	722	3.04	1.46	0.48	744	2.94	1.41	0.48	765
32	18	2.70	2.70	1.00	572	2.59	2.59	1.00	601	2.48	2.48	1.00	629	2.39	2.39	1.00	658
32	20	2.82	2.48	0.88	601	2.70	2.38	0.88	636	2.62	2.31	0.88	651	2.53	2.23	0.88	679
32	22	2.93	2.23	0.76	622	2.83	2.15	0.76	661	2.76	2.10	0.76	679	2.65	2.01	0.76	708
32	24	3.08	1.97	0.64	651	2.97	1.90	0.64	686	2.90	1.85	0.64	708	2.81	1.80	0.64	744
32	26	3.17	1.65	0.52	686	3.08	1.60	0.52	722	3.04	1.58	0.52	744	2.94	1.53	0.52	765

NOTE Q :Total capacity (kW)

SHF :Sensible heat factor

DB :Dry-bulb temperature

SHC :Sensible heat capacity (kW)

INPUT :Total power input (W)

WB :Wet-bulb temperature

PERFORMANCE DATA
COOL operation (230V)

MSC-A07YV -[E1] : MUH-A07YV -[E1]

CAPACITY : 2.3(KW) SHF : 0.74 INPUT : 715(W)

		OUTDOOR DB(°C)											
INDOOR DB(°C)	INDOOR WB(°C)	35				40				43			
		Q	SHC	SHF	INPUT	Q	SHC	SHF	INPUT	Q	SHC	SHF	INPUT
21	18	2.25	1.26	0.56	701	2.07	1.16	0.56	744	1.99	1.11	0.56	758
21	20	2.37	1.04	0.44	729	2.21	0.97	0.44	765	2.13	0.94	0.44	787
22	18	2.25	1.35	0.60	701	2.07	1.24	0.60	744	1.99	1.19	0.60	758
22	20	2.37	1.14	0.48	729	2.21	1.06	0.48	765	2.13	1.02	0.48	787
22	22	2.51	0.90	0.36	758	2.35	0.84	0.36	801	2.27	0.82	0.36	815
23	18	2.25	1.44	0.64	701	2.07	1.32	0.64	744	1.99	1.27	0.64	758
23	20	2.37	1.23	0.52	729	2.21	1.15	0.52	765	2.13	1.11	0.52	787
23	22	2.51	1.00	0.40	758	2.35	0.94	0.40	801	2.27	0.91	0.40	815
24	18	2.25	1.53	0.68	701	2.07	1.41	0.68	744	1.99	1.35	0.68	758
24	20	2.37	1.33	0.56	729	2.21	1.24	0.56	765	2.13	1.19	0.56	787
24	22	2.51	1.10	0.44	758	2.35	1.03	0.44	801	2.27	1.00	0.44	815
24	24	2.65	0.85	0.32	787	2.48	0.79	0.32	822	2.42	0.77	0.32	840
25	18	2.25	1.62	0.72	701	2.07	1.49	0.72	744	1.99	1.43	0.72	758
25	20	2.37	1.42	0.60	729	2.21	1.32	0.60	765	2.13	1.28	0.60	787
25	22	2.51	1.20	0.48	758	2.35	1.13	0.48	801	2.27	1.09	0.48	815
25	24	2.65	0.95	0.36	787	2.48	0.89	0.36	822	2.42	0.87	0.36	840
26	18	2.25	1.71	0.76	701	2.07	1.57	0.76	744	1.99	1.51	0.76	758
26	20	2.37	1.52	0.64	729	2.21	1.41	0.64	765	2.13	1.36	0.64	787
26	22	2.51	1.30	0.52	758	2.35	1.22	0.52	801	2.27	1.18	0.52	815
26	24	2.65	1.06	0.40	787	2.48	0.99	0.40	822	2.42	0.97	0.40	840
26	26	2.78	0.78	0.28	815	2.62	0.73	0.28	851	2.54	0.71	0.28	869
27	18	2.25	1.80	0.80	701	2.07	1.66	0.80	744	1.99	1.59	0.80	758
27	20	2.37	1.61	0.68	729	2.21	1.50	0.68	765	2.13	1.45	0.68	787
27	22	2.51	1.40	0.56	758	2.35	1.31	0.56	801	2.27	1.27	0.56	815
27	24	2.65	1.16	0.44	787	2.48	1.09	0.44	822	2.42	1.06	0.44	840
27	26	2.78	0.89	0.32	815	2.62	0.84	0.32	851	2.54	0.81	0.32	869
28	18	2.25	1.89	0.84	701	2.07	1.74	0.84	744	1.99	1.67	0.84	758
28	20	2.37	1.71	0.72	729	2.21	1.59	0.72	765	2.13	1.53	0.72	787
28	22	2.51	1.50	0.60	758	2.35	1.41	0.60	801	2.27	1.36	0.60	815
28	24	2.65	1.27	0.48	787	2.48	1.19	0.48	822	2.42	1.16	0.48	840
28	26	2.78	1.00	0.36	815	2.62	0.94	0.36	851	2.54	0.91	0.36	869
29	18	2.25	1.98	0.88	701	2.07	1.82	0.88	744	1.99	1.75	0.88	758
29	20	2.37	1.80	0.76	729	2.21	1.68	0.76	765	2.13	1.62	0.76	787
29	22	2.51	1.60	0.64	758	2.35	1.50	0.64	801	2.27	1.45	0.64	815
29	24	2.65	1.38	0.52	787	2.48	1.29	0.52	822	2.42	1.26	0.52	840
29	26	2.78	1.11	0.40	815	2.62	1.05	0.40	851	2.54	1.02	0.40	869
30	18	2.25	2.07	0.92	701	2.07	1.90	0.92	744	1.99	1.83	0.92	758
30	20	2.37	1.90	0.80	729	2.21	1.77	0.80	765	2.13	1.70	0.80	787
30	22	2.51	1.70	0.68	758	2.35	1.60	0.68	801	2.27	1.54	0.68	815
30	24	2.65	1.48	0.56	787	2.48	1.39	0.56	822	2.42	1.35	0.56	840
30	26	2.78	1.22	0.44	815	2.62	1.15	0.44	851	2.54	1.12	0.44	869
31	18	2.25	2.16	0.96	701	2.07	1.99	0.96	744	1.99	1.91	0.96	758
31	20	2.37	1.99	0.84	729	2.21	1.85	0.84	765	2.13	1.79	0.84	787
31	22	2.51	1.81	0.72	758	2.35	1.69	0.72	801	2.27	1.63	0.72	815
31	24	2.65	1.59	0.60	787	2.48	1.49	0.60	822	2.42	1.45	0.60	840
31	26	2.78	1.34	0.48	815	2.62	1.26	0.48	851	2.54	1.22	0.48	869
32	18	2.25	2.25	1.00	701	2.07	2.07	1.00	744	1.99	1.99	1.00	758
32	20	2.37	2.08	0.88	729	2.21	1.94	0.88	765	2.13	1.87	0.88	787
32	22	2.51	1.91	0.76	758	2.35	1.78	0.76	801	2.27	1.72	0.76	815
32	24	2.65	1.69	0.64	787	2.48	1.59	0.64	822	2.42	1.55	0.64	840
32	26	2.78	1.45	0.52	815	2.62	1.36	0.52	851	2.54	1.32	0.52	869

NOTE Q :Total capacity (kW) SHF :Sensible heat factor DB :Dry-bulb temperature
SHC :Sensible heat capacity (kW) INPUT :Total power input (W) WB :Wet-bulb temperature

PERFORMANCE DATA
COOL operation (230V)

MSC-A09YV -[E1] : MUH-A09YV -[E1]

CAPACITY : 2.55(KW) SHF : 0.70 INPUT : 795(W)

		OUTDOOR DB(°C)															
INDOOR DB(°C)	INDOOR WB(°C)	21				25				27				30			
		Q	SHC	SHF	INPUT	Q	SHC	SHF	INPUT	Q	SHC	SHF	INPUT	Q	SHC	SHF	INPUT
21	18	3.00	1.56	0.52	636	2.87	1.49	0.52	668	2.75	1.43	0.52	700	2.65	1.38	0.52	731
21	20	3.12	1.25	0.40	668	3.00	1.20	0.40	708	2.91	1.16	0.40	723	2.81	1.12	0.40	755
22	18	3.00	1.68	0.56	636	2.87	1.61	0.56	668	2.75	1.54	0.56	700	2.65	1.49	0.56	731
22	20	3.12	1.37	0.44	668	3.00	1.32	0.44	708	2.91	1.28	0.44	723	2.81	1.23	0.44	755
22	22	3.25	1.04	0.32	692	3.14	1.00	0.32	735	3.06	0.98	0.32	755	2.93	0.94	0.32	787
23	18	3.00	1.80	0.60	636	2.87	1.72	0.60	668	2.75	1.65	0.60	700	2.65	1.59	0.60	731
23	20	3.12	1.50	0.48	668	3.00	1.44	0.48	708	2.91	1.40	0.48	723	2.81	1.35	0.48	755
23	22	3.25	1.17	0.36	692	3.14	1.13	0.36	735	3.06	1.10	0.36	755	2.93	1.06	0.36	787
24	18	3.00	1.92	0.64	636	2.87	1.84	0.64	668	2.75	1.76	0.64	700	2.65	1.70	0.64	731
24	20	3.12	1.62	0.52	668	3.00	1.56	0.52	708	2.91	1.51	0.52	723	2.81	1.46	0.52	755
24	22	3.25	1.30	0.40	692	3.14	1.25	0.40	735	3.06	1.22	0.40	755	2.93	1.17	0.40	787
24	24	3.42	0.96	0.28	723	3.29	0.92	0.28	763	3.21	0.90	0.28	787	3.11	0.87	0.28	827
25	18	3.00	2.04	0.68	636	2.87	1.95	0.68	668	2.75	1.87	0.68	700	2.65	1.80	0.68	731
25	20	3.12	1.75	0.56	668	3.00	1.68	0.56	708	2.91	1.63	0.56	723	2.81	1.57	0.56	755
25	22	3.25	1.43	0.44	692	3.14	1.38	0.44	735	3.06	1.35	0.44	755	2.93	1.29	0.44	787
25	24	3.42	1.09	0.32	723	3.29	1.05	0.32	763	3.21	1.03	0.32	787	3.11	1.00	0.32	827
26	18	3.00	2.16	0.72	636	2.87	2.07	0.72	668	2.75	1.98	0.72	700	2.65	1.91	0.72	731
26	20	3.12	1.87	0.60	668	3.00	1.80	0.60	708	2.91	1.74	0.60	723	2.81	1.68	0.60	755
26	22	3.25	1.56	0.48	692	3.14	1.51	0.48	735	3.06	1.47	0.48	755	2.93	1.41	0.48	787
26	24	3.42	1.23	0.36	723	3.29	1.18	0.36	763	3.21	1.16	0.36	787	3.11	1.12	0.36	827
26	26	3.52	0.84	0.24	763	3.42	0.82	0.24	803	3.37	0.81	0.24	827	3.26	0.78	0.24	851
27	18	3.00	2.28	0.76	636	2.87	2.18	0.76	668	2.75	2.09	0.76	700	2.65	2.02	0.76	731
27	20	3.12	2.00	0.64	668	3.00	1.92	0.64	708	2.91	1.86	0.64	723	2.81	1.80	0.64	755
27	22	3.25	1.69	0.52	692	3.14	1.63	0.52	735	3.06	1.59	0.52	755	2.93	1.52	0.52	787
27	24	3.42	1.37	0.40	723	3.29	1.32	0.40	763	3.21	1.29	0.40	787	3.11	1.24	0.40	827
27	26	3.52	0.99	0.28	763	3.42	0.96	0.28	803	3.37	0.94	0.28	827	3.26	0.91	0.28	851
28	18	3.00	2.40	0.80	636	2.87	2.30	0.80	668	2.75	2.20	0.80	700	2.65	2.12	0.80	731
28	20	3.12	2.12	0.68	668	3.00	2.04	0.68	708	2.91	1.98	0.68	723	2.81	1.91	0.68	755
28	22	3.25	1.82	0.56	692	3.14	1.76	0.56	735	3.06	1.71	0.56	755	2.93	1.64	0.56	787
28	24	3.42	1.50	0.44	723	3.29	1.45	0.44	763	3.21	1.41	0.44	787	3.11	1.37	0.44	827
28	26	3.52	1.13	0.32	763	3.42	1.09	0.32	803	3.37	1.08	0.32	827	3.26	1.04	0.32	851
29	18	3.00	2.52	0.84	636	2.87	2.41	0.84	668	2.75	2.31	0.84	700	2.65	2.23	0.84	731
29	20	3.12	2.25	0.72	668	3.00	2.16	0.72	708	2.91	2.09	0.72	723	2.81	2.02	0.72	755
29	22	3.25	1.95	0.60	692	3.14	1.88	0.60	735	3.06	1.84	0.60	755	2.93	1.76	0.60	787
29	24	3.42	1.64	0.48	723	3.29	1.58	0.48	763	3.21	1.54	0.48	787	3.11	1.49	0.48	827
29	26	3.52	1.27	0.36	763	3.42	1.23	0.36	803	3.37	1.21	0.36	827	3.26	1.18	0.36	851
30	18	3.00	2.64	0.88	636	2.87	2.52	0.88	668	2.75	2.42	0.88	700	2.65	2.33	0.88	731
30	20	3.12	2.37	0.76	668	3.00	2.28	0.76	708	2.91	2.21	0.76	723	2.81	2.13	0.76	755
30	22	3.25	2.08	0.64	692	3.14	2.01	0.64	735	3.06	1.96	0.64	755	2.93	1.88	0.64	787
30	24	3.42	1.78	0.52	723	3.29	1.71	0.52	763	3.21	1.67	0.52	787	3.11	1.62	0.52	827
30	26	3.52	1.41	0.40	763	3.42	1.37	0.40	803	3.37	1.35	0.40	827	3.26	1.31	0.40	851
31	18	3.00	2.76	0.92	636	2.87	2.64	0.92	668	2.75	2.53	0.92	700	2.65	2.44	0.92	731
31	20	3.12	2.50	0.80	668	3.00	2.40	0.80	708	2.91	2.33	0.80	723	2.81	2.24	0.80	755
31	22	3.25	2.21	0.68	692	3.14	2.13	0.68	735	3.06	2.08	0.68	755	2.93	1.99	0.68	787
31	24	3.42	1.91	0.56	723	3.29	1.84	0.56	763	3.21	1.80	0.56	787	3.11	1.74	0.56	827
31	26	3.52	1.55	0.44	763	3.42	1.50	0.44	803	3.37	1.48	0.44	827	3.26	1.44	0.44	851
32	18	3.00	2.88	0.96	636	2.87	2.75	0.96	668	2.75	2.64	0.96	700	2.65	2.55	0.96	731
32	20	3.12	2.62	0.84	668	3.00	2.52	0.84	708	2.91	2.44	0.84	723	2.81	2.36	0.84	755
32	22	3.25	2.34	0.72	692	3.14	2.26	0.72	735	3.06	2.20	0.72	755	2.93	2.11	0.72	787
32	24	3.42	2.05	0.60	723	3.29	1.97	0.60	763	3.21	1.93	0.60	787	3.11	1.87	0.60	827
32	26	3.52	1.69	0.48	763	3.42	1.64	0.48	803	3.37	1.62	0.48	827	3.26	1.57	0.48	851

NOTE Q :Total capacity (kW) SHF :Sensible heat factor DB :Dry-bulb temperature
 SHC :Sensible heat capacity (kW) INPUT :Total power input (W) WB :Wet-bulb temperature

PERFORMANCE DATA
COOL operation (230V)

MSC-A09YV -[E1] : MUH-A09YV -[E1]

CAPACITY : 2.55(KW) SHF : 0.70 INPUT : 795(W)

		OUTDOOR DB(°C)											
INDOOR DB(°C)	INDOOR WB(°C)	35				40				43			
		Q	SHC	SHF	INPUT	Q	SHC	SHF	INPUT	Q	SHC	SHF	INPUT
21	18	2.50	1.30	0.52	779	2.30	1.19	0.52	827	2.21	1.15	0.52	843
21	20	2.63	1.05	0.40	811	2.45	0.98	0.40	851	2.36	0.94	0.40	875
22	18	2.50	1.40	0.56	779	2.30	1.29	0.56	827	2.21	1.24	0.56	843
22	20	2.63	1.16	0.44	811	2.45	1.08	0.44	851	2.36	1.04	0.44	875
22	22	2.78	0.89	0.32	843	2.60	0.83	0.32	890	2.51	0.80	0.32	906
23	18	2.50	1.50	0.60	779	2.30	1.38	0.60	827	2.21	1.32	0.60	843
23	20	2.63	1.26	0.48	811	2.45	1.18	0.48	851	2.36	1.13	0.48	875
23	22	2.78	1.00	0.36	843	2.60	0.94	0.36	890	2.51	0.90	0.36	906
24	18	2.50	1.60	0.64	779	2.30	1.47	0.64	827	2.21	1.41	0.64	843
24	20	2.63	1.37	0.52	811	2.45	1.27	0.52	851	2.36	1.23	0.52	875
24	22	2.78	1.11	0.40	843	2.60	1.04	0.40	890	2.51	1.00	0.40	906
24	24	2.93	0.82	0.28	875	2.75	0.77	0.28	914	2.68	0.75	0.28	934
25	18	2.50	1.70	0.68	779	2.30	1.56	0.68	827	2.21	1.50	0.68	843
25	20	2.63	1.47	0.56	811	2.45	1.37	0.56	851	2.36	1.32	0.56	875
25	22	2.78	1.22	0.44	843	2.60	1.14	0.44	890	2.51	1.11	0.44	906
25	24	2.93	0.94	0.32	875	2.75	0.88	0.32	914	2.68	0.86	0.32	934
26	18	2.50	1.80	0.72	779	2.30	1.65	0.72	827	2.21	1.59	0.72	843
26	20	2.63	1.58	0.60	811	2.45	1.47	0.60	851	2.36	1.42	0.60	875
26	22	2.78	1.33	0.48	843	2.60	1.25	0.48	890	2.51	1.21	0.48	906
26	24	2.93	1.06	0.36	875	2.75	0.99	0.36	914	2.68	0.96	0.36	934
26	26	3.09	0.74	0.24	906	2.91	0.70	0.24	946	2.82	0.68	0.24	966
27	18	2.50	1.90	0.76	779	2.30	1.74	0.76	827	2.21	1.68	0.76	843
27	20	2.63	1.68	0.64	811	2.45	1.57	0.64	851	2.36	1.51	0.64	875
27	22	2.78	1.45	0.52	843	2.60	1.35	0.52	890	2.51	1.31	0.52	906
27	24	2.93	1.17	0.40	875	2.75	1.10	0.40	914	2.68	1.07	0.40	934
27	26	3.09	0.86	0.28	906	2.91	0.81	0.28	946	2.82	0.79	0.28	966
28	18	2.50	2.00	0.80	779	2.30	1.84	0.80	827	2.21	1.76	0.80	843
28	20	2.63	1.79	0.68	811	2.45	1.66	0.68	851	2.36	1.60	0.68	875
28	22	2.78	1.56	0.56	843	2.60	1.46	0.56	890	2.51	1.41	0.56	906
28	24	2.93	1.29	0.44	875	2.75	1.21	0.44	914	2.68	1.18	0.44	934
28	26	3.09	0.99	0.32	906	2.91	0.93	0.32	946	2.82	0.90	0.32	966
29	18	2.50	2.10	0.84	779	2.30	1.93	0.84	827	2.21	1.85	0.84	843
29	20	2.63	1.89	0.72	811	2.45	1.76	0.72	851	2.36	1.70	0.72	875
29	22	2.78	1.67	0.60	843	2.60	1.56	0.60	890	2.51	1.51	0.60	906
29	24	2.93	1.41	0.48	875	2.75	1.32	0.48	914	2.68	1.29	0.48	934
29	26	3.09	1.11	0.36	906	2.91	1.05	0.36	946	2.82	1.01	0.36	966
30	18	2.50	2.20	0.88	779	2.30	2.02	0.88	827	2.21	1.94	0.88	843
30	20	2.63	2.00	0.76	811	2.45	1.86	0.76	851	2.36	1.79	0.76	875
30	22	2.78	1.78	0.64	843	2.60	1.66	0.64	890	2.51	1.61	0.64	906
30	24	2.93	1.52	0.52	875	2.75	1.43	0.52	914	2.68	1.39	0.52	934
30	26	3.09	1.23	0.40	906	2.91	1.16	0.40	946	2.82	1.13	0.40	966
31	18	2.50	2.30	0.92	779	2.30	2.11	0.92	827	2.21	2.03	0.92	843
31	20	2.63	2.10	0.80	811	2.45	1.96	0.80	851	2.36	1.89	0.80	875
31	22	2.78	1.89	0.68	843	2.60	1.77	0.68	890	2.51	1.71	0.68	906
31	24	2.93	1.64	0.56	875	2.75	1.54	0.56	914	2.68	1.50	0.56	934
31	26	3.09	1.36	0.44	906	2.91	1.28	0.44	946	2.82	1.24	0.44	966
32	18	2.50	2.40	0.96	779	2.30	2.20	0.96	827	2.21	2.12	0.96	843
32	20	2.63	2.21	0.84	811	2.45	2.06	0.84	851	2.36	1.98	0.84	875
32	22	2.78	2.00	0.72	843	2.60	1.87	0.72	890	2.51	1.81	0.72	906
32	24	2.93	1.76	0.60	875	2.75	1.65	0.60	914	2.68	1.61	0.60	934
32	26	3.09	1.48	0.48	906	2.91	1.40	0.48	946	2.82	1.35	0.48	966

NOTE Q :Total capacity (kW) SHF :Sensible heat factor DB :Dry-bulb temperature
SHC :Sensible heat capacity (kW) INPUT :Total power input (W) WB :Wet-bulb temperature

PERFORMANCE DATA

COOL operation (230V)

MSC-A12YV -[E1] : MUH-A12YV -[E1]

CAPACITY : 3.5(KW) SHF : 0.66 INPUT : 1090(W)

		OUTDOOR DB(°C)															
INDOOR DB(°C)	INDOOR WB(°C)	21				25				27				30			
		Q	SHC	SHF	INPUT	Q	SHC	SHF	INPUT	Q	SHC	SHF	INPUT	Q	SHC	SHF	INPUT
21	18	4.11	1.97	0.48	872	3.94	1.89	0.48	916	3.78	1.81	0.48	959	3.64	1.75	0.48	1003
21	20	4.29	1.54	0.36	916	4.11	1.48	0.36	970	3.99	1.44	0.36	992	3.85	1.39	0.36	1036
22	18	4.11	2.14	0.52	872	3.94	2.05	0.52	916	3.78	1.97	0.52	959	3.64	1.89	0.52	1003
22	20	4.29	1.72	0.40	916	4.11	1.65	0.40	970	3.99	1.60	0.40	992	3.85	1.54	0.40	1036
22	22	4.46	1.25	0.28	948	4.31	1.21	0.28	1008	4.20	1.18	0.28	1036	4.03	1.13	0.28	1079
23	18	4.11	2.30	0.56	872	3.94	2.21	0.56	916	3.78	2.12	0.56	959	3.64	2.04	0.56	1003
23	20	4.29	1.89	0.44	916	4.11	1.81	0.44	970	3.99	1.76	0.44	992	3.85	1.69	0.44	1036
23	22	4.46	1.43	0.32	948	4.31	1.38	0.32	1008	4.20	1.34	0.32	1036	4.03	1.29	0.32	1079
24	18	4.11	2.47	0.60	872	3.94	2.36	0.60	916	3.78	2.27	0.60	959	3.64	2.18	0.60	1003
24	20	4.29	2.06	0.48	916	4.11	1.97	0.48	970	3.99	1.92	0.48	992	3.85	1.85	0.48	1036
24	22	4.46	1.61	0.36	948	4.31	1.55	0.36	1008	4.20	1.51	0.36	1036	4.03	1.45	0.36	1079
24	24	4.69	1.13	0.24	992	4.52	1.08	0.24	1046	4.41	1.06	0.24	1079	4.27	1.02	0.24	1134
25	18	4.11	2.63	0.64	872	3.94	2.52	0.64	916	3.78	2.42	0.64	959	3.64	2.33	0.64	1003
25	20	4.29	2.23	0.52	916	4.11	2.14	0.52	970	3.99	2.07	0.52	992	3.85	2.00	0.52	1036
25	22	4.46	1.79	0.40	948	4.31	1.72	0.40	1008	4.20	1.68	0.40	1036	4.03	1.61	0.40	1079
25	24	4.69	1.31	0.28	992	4.52	1.26	0.28	1046	4.41	1.23	0.28	1079	4.27	1.20	0.28	1134
26	18	4.11	2.80	0.68	872	3.94	2.68	0.68	916	3.78	2.57	0.68	959	3.64	2.48	0.68	1003
26	20	4.29	2.40	0.56	916	4.11	2.30	0.56	970	3.99	2.23	0.56	992	3.85	2.16	0.56	1036
26	22	4.46	1.96	0.44	948	4.31	1.89	0.44	1008	4.20	1.85	0.44	1036	4.03	1.77	0.44	1079
26	24	4.69	1.50	0.32	992	4.52	1.44	0.32	1046	4.41	1.41	0.32	1079	4.27	1.37	0.32	1134
26	26	4.83	0.97	0.20	1046	4.69	0.94	0.20	1101	4.62	0.92	0.20	1134	4.48	0.90	0.20	1166
27	18	4.11	2.96	0.72	872	3.94	2.84	0.72	916	3.78	2.72	0.72	959	3.64	2.62	0.72	1003
27	20	4.29	2.57	0.60	916	4.11	2.47	0.60	970	3.99	2.39	0.60	992	3.85	2.31	0.60	1036
27	22	4.46	2.14	0.48	948	4.31	2.07	0.48	1008	4.20	2.02	0.48	1036	4.03	1.93	0.48	1079
27	24	4.69	1.69	0.36	992	4.52	1.63	0.36	1046	4.41	1.59	0.36	1079	4.27	1.54	0.36	1134
27	26	4.83	1.16	0.24	1046	4.69	1.13	0.24	1101	4.62	1.11	0.24	1134	4.48	1.08	0.24	1166
28	18	4.11	3.13	0.76	872	3.94	2.99	0.76	916	3.78	2.87	0.76	959	3.64	2.77	0.76	1003
28	20	4.29	2.74	0.64	916	4.11	2.63	0.64	970	3.99	2.55	0.64	992	3.85	2.46	0.64	1036
28	22	4.46	2.32	0.52	948	4.31	2.24	0.52	1008	4.20	2.18	0.52	1036	4.03	2.09	0.52	1079
28	24	4.69	1.88	0.40	992	4.52	1.81	0.40	1046	4.41	1.76	0.40	1079	4.27	1.71	0.40	1134
28	26	4.83	1.35	0.28	1046	4.69	1.31	0.28	1101	4.62	1.29	0.28	1134	4.48	1.25	0.28	1166
29	18	4.11	3.29	0.80	872	3.94	3.15	0.80	916	3.78	3.02	0.80	959	3.64	2.91	0.80	1003
29	20	4.29	2.92	0.68	916	4.11	2.80	0.68	970	3.99	2.71	0.68	992	3.85	2.62	0.68	1036
29	22	4.46	2.50	0.56	948	4.31	2.41	0.56	1008	4.20	2.35	0.56	1036	4.03	2.25	0.56	1079
29	24	4.69	2.06	0.44	992	4.52	1.99	0.44	1046	4.41	1.94	0.44	1079	4.27	1.88	0.44	1134
29	26	4.83	1.55	0.32	1046	4.69	1.50	0.32	1101	4.62	1.48	0.32	1134	4.48	1.43	0.32	1166
30	18	4.11	3.45	0.84	872	3.94	3.31	0.84	916	3.78	3.18	0.84	959	3.64	3.06	0.84	1003
30	20	4.29	3.09	0.72	916	4.11	2.96	0.72	970	3.99	2.87	0.72	992	3.85	2.77	0.72	1036
30	22	4.46	2.68	0.60	948	4.31	2.58	0.60	1008	4.20	2.52	0.60	1036	4.03	2.42	0.60	1079
30	24	4.69	2.25	0.48	992	4.52	2.17	0.48	1046	4.41	2.12	0.48	1079	4.27	2.05	0.48	1134
30	26	4.83	1.74	0.36	1046	4.69	1.69	0.36	1101	4.62	1.66	0.36	1134	4.48	1.61	0.36	1166
31	18	4.11	3.62	0.88	872	3.94	3.47	0.88	916	3.78	3.33	0.88	959	3.64	3.20	0.88	1003
31	20	4.29	3.26	0.76	916	4.11	3.13	0.76	970	3.99	3.03	0.76	992	3.85	2.93	0.76	1036
31	22	4.46	2.86	0.64	948	4.31	2.76	0.64	1008	4.20	2.69	0.64	1036	4.03	2.58	0.64	1079
31	24	4.69	2.44	0.52	992	4.52	2.35	0.52	1046	4.41	2.29	0.52	1079	4.27	2.22	0.52	1134
31	26	4.83	1.93	0.40	1046	4.69	1.88	0.40	1101	4.62	1.85	0.40	1134	4.48	1.79	0.40	1166
32	18	4.11	3.78	0.92	872	3.94	3.62	0.92	916	3.78	3.48	0.92	959	3.64	3.35	0.92	1003
32	20	4.29	3.43	0.80	916	4.11	3.29	0.80	970	3.99	3.19	0.80	992	3.85	3.08	0.80	1036
32	22	4.46	3.03	0.68	948	4.31	2.93	0.68	1008	4.20	2.86	0.68	1036	4.03	2.74	0.68	1079
32	24	4.69	2.63	0.56	992	4.52	2.53	0.56	1046	4.41	2.47	0.56	1079	4.27	2.39	0.56	1134
32	26	4.83	2.13	0.44	1046	4.69	2.06	0.44	1101	4.62	2.03	0.44	1134	4.48	1.97	0.44	1166

NOTE Q :Total capacity (kW)

SHF :Sensible heat factor

DB :Dry-bulb temperature

SHC :Sensible heat capacity (kW)

INPUT :Total power input (W)

WB :Wet-bulb temperature

PERFORMANCE DATA
COOL operation (230V)

MSC-A12YV -[E1] : MUH-A12YV -[E1]

CAPACITY : 3.5(KW) SHF : 0.66 INPUT : 1090(W)

		OUTDOOR DB(°C)											
INDOOR DB(°C)	INDOOR WB(°C)	35				40				43			
		Q	SHC	SHF	INPUT	Q	SHC	SHF	INPUT	Q	SHC	SHF	INPUT
21	18	3.43	1.65	0.48	1068	3.15	1.51	0.48	1134	3.03	1.45	0.48	1155
21	20	3.61	1.30	0.36	1112	3.36	1.21	0.36	1166	3.24	1.17	0.36	1199
22	18	3.43	1.78	0.52	1068	3.15	1.64	0.52	1134	3.03	1.57	0.52	1155
22	20	3.61	1.44	0.40	1112	3.36	1.34	0.40	1166	3.24	1.30	0.40	1199
22	22	3.82	1.07	0.28	1155	3.57	1.00	0.28	1221	3.45	0.97	0.28	1243
23	18	3.43	1.92	0.56	1068	3.15	1.76	0.56	1134	3.03	1.70	0.56	1155
23	20	3.61	1.59	0.44	1112	3.36	1.48	0.44	1166	3.24	1.42	0.44	1199
23	22	3.82	1.22	0.32	1155	3.57	1.14	0.32	1221	3.45	1.10	0.32	1243
24	18	3.43	2.06	0.60	1068	3.15	1.89	0.60	1134	3.03	1.82	0.60	1155
24	20	3.61	1.73	0.48	1112	3.36	1.61	0.48	1166	3.24	1.55	0.48	1199
24	22	3.82	1.37	0.36	1155	3.57	1.29	0.36	1221	3.45	1.24	0.36	1243
24	24	4.03	0.97	0.24	1199	3.78	0.91	0.24	1254	3.68	0.88	0.24	1281
25	18	3.43	2.20	0.64	1068	3.15	2.02	0.64	1134	3.03	1.94	0.64	1155
25	20	3.61	1.87	0.52	1112	3.36	1.75	0.52	1166	3.24	1.68	0.52	1199
25	22	3.82	1.53	0.40	1155	3.57	1.43	0.40	1221	3.45	1.38	0.40	1243
25	24	4.03	1.13	0.28	1199	3.78	1.06	0.28	1254	3.68	1.03	0.28	1281
26	18	3.43	2.33	0.68	1068	3.15	2.14	0.68	1134	3.03	2.06	0.68	1155
26	20	3.61	2.02	0.56	1112	3.36	1.88	0.56	1166	3.24	1.81	0.56	1199
26	22	3.82	1.68	0.44	1155	3.57	1.57	0.44	1221	3.45	1.52	0.44	1243
26	24	4.03	1.29	0.32	1199	3.78	1.21	0.32	1254	3.68	1.18	0.32	1281
26	26	4.24	0.85	0.20	1243	3.99	0.80	0.20	1297	3.87	0.77	0.20	1324
27	18	3.43	2.47	0.72	1068	3.15	2.27	0.72	1134	3.03	2.18	0.72	1155
27	20	3.61	2.16	0.60	1112	3.36	2.02	0.60	1166	3.24	1.94	0.60	1199
27	22	3.82	1.83	0.48	1155	3.57	1.71	0.48	1221	3.45	1.65	0.48	1243
27	24	4.03	1.45	0.36	1199	3.78	1.36	0.36	1254	3.68	1.32	0.36	1281
27	26	4.24	1.02	0.24	1243	3.99	0.96	0.24	1297	3.87	0.93	0.24	1324
28	18	3.43	2.61	0.76	1068	3.15	2.39	0.76	1134	3.03	2.30	0.76	1155
28	20	3.61	2.31	0.64	1112	3.36	2.15	0.64	1166	3.24	2.07	0.64	1199
28	22	3.82	1.98	0.52	1155	3.57	1.86	0.52	1221	3.45	1.79	0.52	1243
28	24	4.03	1.61	0.40	1199	3.78	1.51	0.40	1254	3.68	1.47	0.40	1281
28	26	4.24	1.19	0.28	1243	3.99	1.12	0.28	1297	3.87	1.08	0.28	1324
29	18	3.43	2.74	0.80	1068	3.15	2.52	0.80	1134	3.03	2.42	0.80	1155
29	20	3.61	2.45	0.68	1112	3.36	2.28	0.68	1166	3.24	2.20	0.68	1199
29	22	3.82	2.14	0.56	1155	3.57	2.00	0.56	1221	3.45	1.93	0.56	1243
29	24	4.03	1.77	0.44	1199	3.78	1.66	0.44	1254	3.68	1.62	0.44	1281
29	26	4.24	1.36	0.32	1243	3.99	1.28	0.32	1297	3.87	1.24	0.32	1324
30	18	3.43	2.88	0.84	1068	3.15	2.65	0.84	1134	3.03	2.54	0.84	1155
30	20	3.61	2.60	0.72	1112	3.36	2.42	0.72	1166	3.24	2.33	0.72	1199
30	22	3.82	2.29	0.60	1155	3.57	2.14	0.60	1221	3.45	2.07	0.60	1243
30	24	4.03	1.93	0.48	1199	3.78	1.81	0.48	1254	3.68	1.76	0.48	1281
30	26	4.24	1.52	0.36	1243	3.99	1.44	0.36	1297	3.87	1.39	0.36	1324
31	18	3.43	3.02	0.88	1068	3.15	2.77	0.88	1134	3.03	2.66	0.88	1155
31	20	3.61	2.74	0.76	1112	3.36	2.55	0.76	1166	3.24	2.46	0.76	1199
31	22	3.82	2.44	0.64	1155	3.57	2.28	0.64	1221	3.45	2.21	0.64	1243
31	24	4.03	2.09	0.52	1199	3.78	1.97	0.52	1254	3.68	1.91	0.52	1281
31	26	4.24	1.69	0.40	1243	3.99	1.60	0.40	1297	3.87	1.55	0.40	1324
32	18	3.43	3.16	0.92	1068	3.15	2.90	0.92	1134	3.03	2.79	0.92	1155
32	20	3.61	2.88	0.80	1112	3.36	2.69	0.80	1166	3.24	2.59	0.80	1199
32	22	3.82	2.59	0.68	1155	3.57	2.43	0.68	1221	3.45	2.34	0.68	1243
32	24	4.03	2.25	0.56	1199	3.78	2.12	0.56	1254	3.68	2.06	0.56	1281
32	26	4.24	1.86	0.44	1243	3.99	1.76	0.44	1297	3.87	1.70	0.44	1324

NOTE Q :Total capacity (kW) SHF :Sensible heat factor DB :Dry-bulb temperature
SHC :Sensible heat capacity (kW) INPUT :Total power input (W) WB :Wet-bulb temperature

PERFORMANCE DATA

COOL operation (230V)

MCFH-A12WV -[E1] : MUH-A12YV -[E1]

CAPACITY :3.5(KW) SHF :0.70 INPUT :1160(W)

		OUTDOOR DB(°C)															
INDOOR DB(°C)	INDOOR WB(°C)	21				25				27				30			
		Q	SHC	SHF	INPUT	Q	SHC	SHF	INPUT	Q	SHC	SHF	INPUT	Q	SHC	SHF	INPUT
21	18	4.11	2.14	0.52	928	3.94	2.05	0.52	974	3.78	1.97	0.52	1021	3.64	1.89	0.52	1067
21	20	4.29	1.72	0.40	974	4.11	1.65	0.40	1032	3.99	1.60	0.40	1056	3.85	1.54	0.40	1102
22	18	4.11	2.30	0.56	928	3.94	2.21	0.56	974	3.78	2.12	0.56	1021	3.64	2.04	0.56	1067
22	20	4.29	1.89	0.44	974	4.11	1.81	0.44	1032	3.99	1.76	0.44	1056	3.85	1.69	0.44	1102
22	22	4.46	1.43	0.32	1009	4.31	1.38	0.32	1073	4.20	1.34	0.32	1102	4.03	1.29	0.32	1148
23	18	4.11	2.47	0.60	928	3.94	2.36	0.60	974	3.78	2.27	0.60	1021	3.64	2.18	0.60	1067
23	20	4.29	2.06	0.48	974	4.11	1.97	0.48	1032	3.99	1.92	0.48	1056	3.85	1.85	0.48	1102
23	22	4.46	1.61	0.36	1009	4.31	1.55	0.36	1073	4.20	1.51	0.36	1102	4.03	1.45	0.36	1148
24	18	4.11	2.63	0.64	928	3.94	2.52	0.64	974	3.78	2.42	0.64	1021	3.64	2.33	0.64	1067
24	20	4.29	2.23	0.52	974	4.11	2.14	0.52	1032	3.99	2.07	0.52	1056	3.85	2.00	0.52	1102
24	22	4.46	1.79	0.40	1009	4.31	1.72	0.40	1073	4.20	1.68	0.40	1102	4.03	1.61	0.40	1148
24	24	4.69	1.31	0.28	1056	4.52	1.26	0.28	1114	4.41	1.23	0.28	1148	4.27	1.20	0.28	1206
25	18	4.11	2.80	0.68	928	3.94	2.68	0.68	974	3.78	2.57	0.68	1021	3.64	2.48	0.68	1067
25	20	4.29	2.40	0.56	974	4.11	2.30	0.56	1032	3.99	2.23	0.56	1056	3.85	2.16	0.56	1102
25	22	4.46	1.96	0.44	1009	4.31	1.89	0.44	1073	4.20	1.85	0.44	1102	4.03	1.77	0.44	1148
25	24	4.69	1.50	0.32	1056	4.52	1.44	0.32	1114	4.41	1.41	0.32	1148	4.27	1.37	0.32	1206
26	18	4.11	2.96	0.72	928	3.94	2.84	0.72	974	3.78	2.72	0.72	1021	3.64	2.62	0.72	1067
26	20	4.29	2.57	0.60	974	4.11	2.47	0.60	1032	3.99	2.39	0.60	1056	3.85	2.31	0.60	1102
26	22	4.46	2.14	0.48	1009	4.31	2.07	0.48	1073	4.20	2.02	0.48	1102	4.03	1.93	0.48	1148
26	24	4.69	1.69	0.36	1056	4.52	1.63	0.36	1114	4.41	1.59	0.36	1148	4.27	1.54	0.36	1206
26	26	4.83	1.16	0.24	1114	4.69	1.13	0.24	1172	4.62	1.11	0.24	1206	4.48	1.08	0.24	1241
27	18	4.11	3.13	0.76	928	3.94	2.99	0.76	974	3.78	2.87	0.76	1021	3.64	2.77	0.76	1067
27	20	4.29	2.74	0.64	974	4.11	2.63	0.64	1032	3.99	2.55	0.64	1056	3.85	2.46	0.64	1102
27	22	4.46	2.32	0.52	1009	4.31	2.24	0.52	1073	4.20	2.18	0.52	1102	4.03	2.09	0.52	1148
27	24	4.69	1.88	0.40	1056	4.52	1.81	0.40	1114	4.41	1.76	0.40	1148	4.27	1.71	0.40	1206
27	26	4.83	1.35	0.28	1114	4.69	1.31	0.28	1172	4.62	1.29	0.28	1206	4.48	1.25	0.28	1241
28	18	4.11	3.29	0.80	928	3.94	3.15	0.80	974	3.78	3.02	0.80	1021	3.64	2.91	0.80	1067
28	20	4.29	2.92	0.68	974	4.11	2.80	0.68	1032	3.99	2.71	0.68	1056	3.85	2.62	0.68	1102
28	22	4.46	2.50	0.56	1009	4.31	2.41	0.56	1073	4.20	2.35	0.56	1102	4.03	2.25	0.56	1148
28	24	4.69	2.06	0.44	1056	4.52	1.99	0.44	1114	4.41	1.94	0.44	1148	4.27	1.88	0.44	1206
28	26	4.83	1.55	0.32	1114	4.69	1.50	0.32	1172	4.62	1.48	0.32	1206	4.48	1.43	0.32	1241
29	18	4.11	3.45	0.84	928	3.94	3.31	0.84	974	3.78	3.18	0.84	1021	3.64	3.06	0.84	1067
29	20	4.29	3.09	0.72	974	4.11	2.96	0.72	1032	3.99	2.87	0.72	1056	3.85	2.77	0.72	1102
29	22	4.46	2.68	0.60	1009	4.31	2.58	0.60	1073	4.20	2.52	0.60	1102	4.03	2.42	0.60	1148
29	24	4.69	2.25	0.48	1056	4.52	2.17	0.48	1114	4.41	2.12	0.48	1148	4.27	2.05	0.48	1206
29	26	4.83	1.74	0.36	1114	4.69	1.69	0.36	1172	4.62	1.66	0.36	1206	4.48	1.61	0.36	1241
30	18	4.11	3.62	0.88	928	3.94	3.47	0.88	974	3.78	3.33	0.88	1021	3.64	3.20	0.88	1067
30	20	4.29	3.26	0.76	974	4.11	3.13	0.76	1032	3.99	3.03	0.76	1056	3.85	2.93	0.76	1102
30	22	4.46	2.86	0.64	1009	4.31	2.76	0.64	1073	4.20	2.69	0.64	1102	4.03	2.58	0.64	1148
30	24	4.69	2.44	0.52	1056	4.52	2.35	0.52	1114	4.41	2.29	0.52	1148	4.27	2.22	0.52	1206
30	26	4.83	1.93	0.40	1114	4.69	1.88	0.40	1172	4.62	1.85	0.40	1206	4.48	1.79	0.40	1241
31	18	4.11	3.78	0.92	928	3.94	3.62	0.92	974	3.78	3.48	0.92	1021	3.64	3.35	0.92	1067
31	20	4.29	3.43	0.80	974	4.11	3.29	0.80	1032	3.99	3.19	0.80	1056	3.85	3.08	0.80	1102
31	22	4.46	3.03	0.68	1009	4.31	2.93	0.68	1073	4.20	2.86	0.68	1102	4.03	2.74	0.68	1148
31	24	4.69	2.63	0.56	1056	4.52	2.53	0.56	1114	4.41	2.47	0.56	1148	4.27	2.39	0.56	1206
31	26	4.83	2.13	0.44	1114	4.69	2.06	0.44	1172	4.62	2.03	0.44	1206	4.48	1.97	0.44	1241
32	18	4.11	3.95	0.96	928	3.94	3.78	0.96	974	3.78	3.63	0.96	1021	3.64	3.49	0.96	1067
32	20	4.29	3.60	0.84	974	4.11	3.45	0.84	1032	3.99	3.35	0.84	1056	3.85	3.23	0.84	1102
32	22	4.46	3.21	0.72	1009	4.31	3.10	0.72	1073	4.20	3.02	0.72	1102	4.03	2.90	0.72	1148
32	24	4.69	2.81	0.60	1056	4.52	2.71	0.60	1114	4.41	2.65	0.60	1148	4.27	2.56	0.60	1206
32	26	4.83	2.32	0.48	1114	4.69	2.25	0.48	1172	4.62	2.22	0.48	1206	4.48	2.15	0.48	1241

NOTE Q :Total capacity (kW) SHF :Sensible heat factor DB :Dry-bulb temperature
 SHC :Sensible heat capacity (kW) INPUT :Total power input (W) WB :Wet-bulb temperature

PERFORMANCE DATA

COOL operation (230V)

MCFH-A12WV -[E1] : MUH-A12YV -[E1]

CAPACITY :3.5(KW) SHF :0.70 INPUT :1160(W)

		OUTDOOR DB(°C)											
INDOOR DB(°C)	INDOOR WB(°C)	35				40				43			
		Q	SHC	SHF	INPUT	Q	SHC	SHF	INPUT	Q	SHC	SHF	INPUT
21	18	3.43	1.78	0.52	1137	3.15	1.64	0.52	1206	3.03	1.57	0.52	1230
21	20	3.61	1.44	0.40	1183	3.36	1.34	0.40	1241	3.24	1.30	0.40	1276
22	18	3.43	1.92	0.56	1137	3.15	1.76	0.56	1206	3.03	1.70	0.56	1230
22	20	3.61	1.59	0.44	1183	3.36	1.48	0.44	1241	3.24	1.42	0.44	1276
22	22	3.82	1.22	0.32	1230	3.57	1.14	0.32	1299	3.45	1.10	0.32	1322
23	18	3.43	2.06	0.60	1137	3.15	1.89	0.60	1206	3.03	1.82	0.60	1230
23	20	3.61	1.73	0.48	1183	3.36	1.61	0.48	1241	3.24	1.55	0.48	1276
23	22	3.82	1.37	0.36	1230	3.57	1.29	0.36	1299	3.45	1.24	0.36	1322
24	18	3.43	2.20	0.64	1137	3.15	2.02	0.64	1206	3.03	1.94	0.64	1230
24	20	3.61	1.87	0.52	1183	3.36	1.75	0.52	1241	3.24	1.68	0.52	1276
24	22	3.82	1.53	0.40	1230	3.57	1.43	0.40	1299	3.45	1.38	0.40	1322
24	24	4.03	1.13	0.28	1276	3.78	1.06	0.28	1334	3.68	1.03	0.28	1363
25	18	3.43	2.33	0.68	1137	3.15	2.14	0.68	1206	3.03	2.06	0.68	1230
25	20	3.61	2.02	0.56	1183	3.36	1.88	0.56	1241	3.24	1.81	0.56	1276
25	22	3.82	1.68	0.44	1230	3.57	1.57	0.44	1299	3.45	1.52	0.44	1322
25	24	4.03	1.29	0.32	1276	3.78	1.21	0.32	1334	3.68	1.18	0.32	1363
26	18	3.43	2.47	0.72	1137	3.15	2.27	0.72	1206	3.03	2.18	0.72	1230
26	20	3.61	2.16	0.60	1183	3.36	2.02	0.60	1241	3.24	1.94	0.60	1276
26	22	3.82	1.83	0.48	1230	3.57	1.71	0.48	1299	3.45	1.65	0.48	1322
26	24	4.03	1.45	0.36	1276	3.78	1.36	0.36	1334	3.68	1.32	0.36	1363
26	26	4.24	1.02	0.24	1322	3.99	0.96	0.24	1380	3.87	0.93	0.24	1409
27	18	3.43	2.61	0.76	1137	3.15	2.39	0.76	1206	3.03	2.30	0.76	1230
27	20	3.61	2.31	0.64	1183	3.36	2.15	0.64	1241	3.24	2.07	0.64	1276
27	22	3.82	1.98	0.52	1230	3.57	1.86	0.52	1299	3.45	1.79	0.52	1322
27	24	4.03	1.61	0.40	1276	3.78	1.51	0.40	1334	3.68	1.47	0.40	1363
27	26	4.24	1.19	0.28	1322	3.99	1.12	0.28	1380	3.87	1.08	0.28	1409
28	18	3.43	2.74	0.80	1137	3.15	2.52	0.80	1206	3.03	2.42	0.80	1230
28	20	3.61	2.45	0.68	1183	3.36	2.28	0.68	1241	3.24	2.20	0.68	1276
28	22	3.82	2.14	0.56	1230	3.57	2.00	0.56	1299	3.45	1.93	0.56	1322
28	24	4.03	1.77	0.44	1276	3.78	1.66	0.44	1334	3.68	1.62	0.44	1363
28	26	4.24	1.36	0.32	1322	3.99	1.28	0.32	1380	3.87	1.24	0.32	1409
29	18	3.43	2.88	0.84	1137	3.15	2.65	0.84	1206	3.03	2.54	0.84	1230
29	20	3.61	2.60	0.72	1183	3.36	2.42	0.72	1241	3.24	2.33	0.72	1276
29	22	3.82	2.29	0.60	1230	3.57	2.14	0.60	1299	3.45	2.07	0.60	1322
29	24	4.03	1.93	0.48	1276	3.78	1.81	0.48	1334	3.68	1.76	0.48	1363
29	26	4.24	1.52	0.36	1322	3.99	1.44	0.36	1380	3.87	1.39	0.36	1409
30	18	3.43	3.02	0.88	1137	3.15	2.77	0.88	1206	3.03	2.66	0.88	1230
30	20	3.61	2.74	0.76	1183	3.36	2.55	0.76	1241	3.24	2.46	0.76	1276
30	22	3.82	2.44	0.64	1230	3.57	2.28	0.64	1299	3.45	2.21	0.64	1322
30	24	4.03	2.09	0.52	1276	3.78	1.97	0.52	1334	3.68	1.91	0.52	1363
30	26	4.24	1.69	0.40	1322	3.99	1.60	0.40	1380	3.87	1.55	0.40	1409
31	18	3.43	3.16	0.92	1137	3.15	2.90	0.92	1206	3.03	2.79	0.92	1230
31	20	3.61	2.88	0.80	1183	3.36	2.69	0.80	1241	3.24	2.59	0.80	1276
31	22	3.82	2.59	0.68	1230	3.57	2.43	0.68	1299	3.45	2.34	0.68	1322
31	24	4.03	2.25	0.56	1276	3.78	2.12	0.56	1334	3.68	2.06	0.56	1363
31	26	4.24	1.86	0.44	1322	3.99	1.76	0.44	1380	3.87	1.70	0.44	1409
32	18	3.43	3.29	0.96	1137	3.15	3.02	0.96	1206	3.03	2.91	0.96	1230
32	20	3.61	3.03	0.84	1183	3.36	2.82	0.84	1241	3.24	2.72	0.84	1276
32	22	3.82	2.75	0.72	1230	3.57	2.57	0.72	1299	3.45	2.48	0.72	1322
32	24	4.03	2.42	0.60	1276	3.78	2.27	0.60	1334	3.68	2.21	0.60	1363
32	26	4.24	2.03	0.48	1322	3.99	1.92	0.48	1380	3.87	1.86	0.48	1409

NOTE Q :Total capacity (kW) SHF :Sensible heat factor DB :Dry-bulb temperature
 SHC :Sensible heat capacity (kW) INPUT :Total power input (W) WB :Wet-bulb temperature

PERFORMANCE DATA**HEAT operation (230V)****MSC-A07YV -[E1] : MUH-A07YV -[E1]**

CAPACITY : 2.5(KW) INPUT : 690(W)

INDOOR DB(°C)	OUTDOOR WB(°C)													
	-10		-5		0		5		10		15		20	
	Q	INPUT	Q	INPUT	Q	INPUT	Q	INPUT	Q	INPUT	Q	INPUT	Q	INPUT
15	1.58	449	1.90	538	2.23	607	2.55	656	2.88	697	3.18	718	3.50	731
21	1.50	483	1.80	573	2.13	635	2.43	683	2.75	718	3.05	738	3.36	766
26	1.35	518	1.68	607	1.98	669	2.30	718	2.63	752	2.93	773	3.25	794

MSC-A09YV -[E1] : MUH-A09YV -[E1]

CAPACITY : 3.05(KW) INPUT : 840(W)

INDOOR DB(°C)	OUTDOOR WB(°C)													
	-10		-5		0		5		10		15		20	
	Q	INPUT	Q	INPUT	Q	INPUT	Q	INPUT	Q	INPUT	Q	INPUT	Q	INPUT
15	1.92	546	2.32	655	2.71	739	3.11	798	3.51	848	3.87	874	4.27	890
21	1.83	588	2.20	697	2.59	773	2.96	832	3.36	874	3.72	899	4.10	932
26	1.65	630	2.04	739	2.41	815	2.81	874	3.20	916	3.57	941	3.97	966

MSC-A12YV -[E1] : MUH-A12YV -[E1]

CAPACITY : 3.9(KW) INPUT : 1080(W)

INDOOR DB(°C)	OUTDOOR WB(°C)													
	-10		-5		0		5		10		15		20	
	Q	INPUT	Q	INPUT	Q	INPUT	Q	INPUT	Q	INPUT	Q	INPUT	Q	INPUT
15	2.46	702	2.96	842	3.47	950	3.98	1026	4.49	1091	4.95	1123	5.46	1145
21	2.34	756	2.81	896	3.32	994	3.78	1069	4.29	1123	4.76	1156	5.25	1199
26	2.11	810	2.61	950	3.08	1048	3.59	1123	4.10	1177	4.56	1210	5.07	1242

MCFH-A12WV -[E1] : MUH-A12YV -[E1]

CAPACITY : 3.7(KW) INPUT : 1020(W)

INDOOR DB(°C)	OUTDOOR WB(°C)													
	-10		-5		0		5		10		15		20	
	Q	INPUT	Q	INPUT	Q	INPUT	Q	INPUT	Q	INPUT	Q	INPUT	Q	INPUT
15	2.33	663	2.81	796	3.29	898	3.77	969	4.26	1030	4.70	1061	5.18	1081
21	2.22	714	2.66	847	3.15	938	3.59	1010	4.07	1061	4.51	1091	4.98	1132
26	2.00	765	2.48	898	2.92	989	3.40	1061	3.89	1112	4.33	1142	4.81	1173

NOTE Q:Total capacity (kW) INPUT:Total power input (W) DB:Dry-bulb temperature WB:Wet-bulb temperature

MUH-A07YV -^[E1]

MUH-A09YV -^[E1]

MUH-A12YV -^[E1]

9-1. HEAT () OPERATION

1. High pressure protection

During heating operation, the outdoor fan motor is controlled by the temperature of indoor coil thermistor RT12 for excess rise protection of compressor discharge pressure.

Outdoor fan OFF: 52°C

Outdoor fan ON: 48°C

Operation chart

Example

Indoor coil thermistor
RT12 temperature

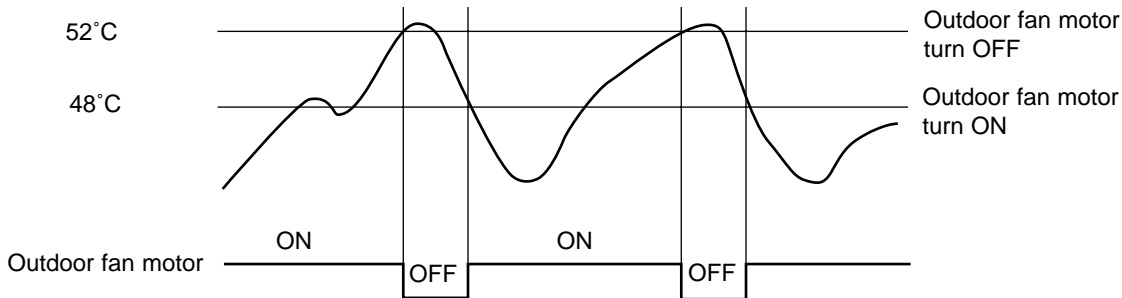

NOTE : During high pressure protection and for 4 min. and 15 sec. after high pressure protection, defrosting of outdoor heat exchanger is not detected by the defrost thermistor RT61.(Refer to 9-1.2. Defrosting.)

2. Defrosting

Defrosting of outdoor heat exchanger is controlled by DEICER P.C. board, with detection by the defrost thermistor RT61.

(1) Starting conditions of defrost

When all conditions of a) ~ c) are satisfied, the defrosting operation starts.

- The compressor cumulative operation time exceeds 40 minutes without the defrosting operation working.
- RT61 reads - 3°C or less.
- After releasing the high pressure protection 4 minutes and 15 seconds have elapsed.

(2) Releasing conditions of defrost

When the condition d) or e) is satisfied, the defrosting operation stops.

- RT61 reads 10.1°C or more.
- The defrosting time exceeds 10 minutes.

Operation time chart

Example

Defrost thermistor RT61

10.1°C or more

-3°C or less

Outdoor 52C
contactor
(Compressor)

X62
(R.V. coil)

SR61
Outdoor fan

Defrost
counter

Indoor fan

Indoor
Horizontal
Horizontal vane

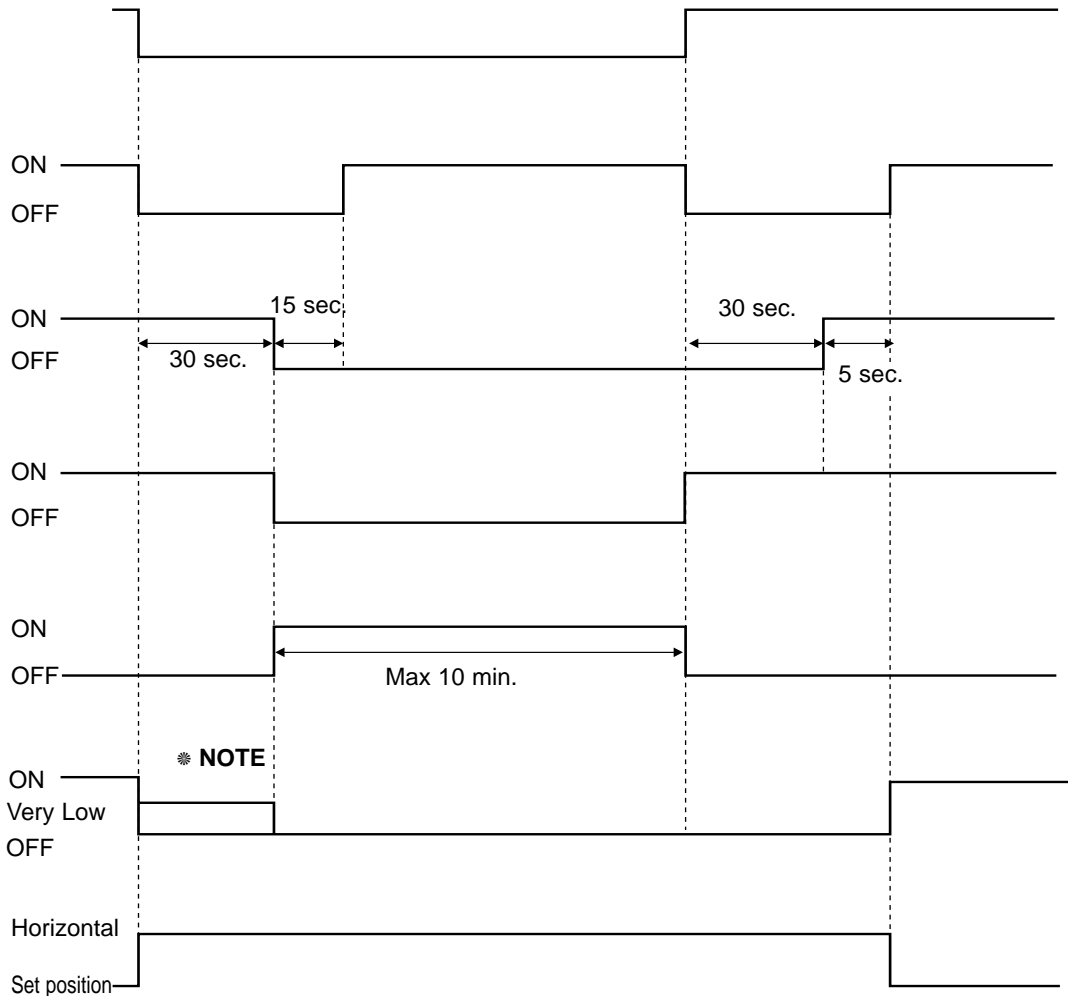

NOTE ● When the indoor coil thermistor RT12 reads above 0°C, indoor fan operates at Very Low for 30 seconds.
● When the indoor coil thermistor RT12 reads 0°C or less, the indoor fan stops.

3. R.V. coil control

Heating ON

Cooling OFF

Dry OFF

When operation starts, the 4-way valve reverses for 5 seconds right before start-up of the compressor.

Operation time chart

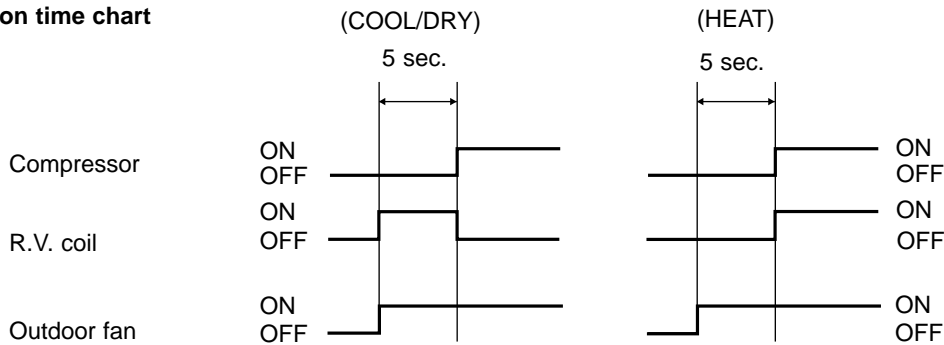

9-2. "I FEEL CONTROL" (□) OPERATION

1. HEAT mode of "I FEEL CONTROL"

1. High pressure protection

High pressure protection is as same as HEAT OPERATION.(9-1.1.)

2. Defrosting

Defrosting is as same as HEAT OPERATION.(9-1.2.)

3. R.V. coil control

R.V. coil control is as same as HEAT OPERATION.(9-1.3.)

MUH-A07YV - [E1]

MUH-A09YV - [E1]

MUH-A12YV - [E1]

10-1. COMPULSORY DEFROSTING MODE FOR SERVICE

By short circuit of the connector JPDS and JPSG on the outdoor deicer P.C. board, defrosting mode can be accomplished regardless of the defrost interval restriction. (Refer to page 30.)

Defrost thermistor RT61 must read below -3°C .

10-2. CHANGE IN DEFROST SETTING

<JRF> When the JRF wire of the deicer P.C. board is cut, the defrost interval time will be changed.

<JRG> When the JRG wire of the deicer P.C. board is cut, the defrost temperature will be changed. (Refer to page 30.)

MODEL	Jumper wire	Change point
MUH-A07YV - [E1] MUH-A09YV - [E1]	JRF	Defrost interval time changes from 40 minutes to 15 minutes.
MUH-A12YV - [E1]	JRG	Defrost start temperature changes from -3°C to 0°C .

MUH-A07YV - [E1]

MUH-A09YV - [E1]

MUH-A12YV - [E1]

11-1. Cautions on troubleshooting

1. Before troubleshooting, check the following:

- 1) Check the power supply voltage.
- 2) Check the indoor/outdoor connecting wire for mis-wiring.

2. Take care the following during servicing.

- 1) Before servicing the air conditioner, be sure to first turn off the remote controller to stop the unit, and then after confirming the horizontal vane is closed, turn off the breaker and/or disconnect the power plug.
- 2) Be sure to turn OFF the power supply before removing the front panel, the cabinet, the top panel, and the electronic control P.C. board.
- 3) When removing the electronic control P.C. board, hold the edge of the board with care NOT to apply stress on the components.
- 4) When connecting or disconnecting the connectors, hold the housing of the connector. DO NOT pull the lead wires.

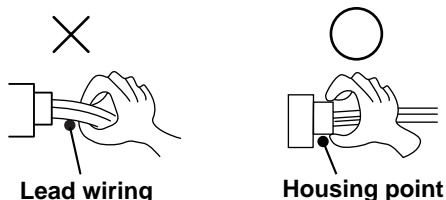

3. Troubleshooting procedure

- 1) First, check if the OPERATION INDICATOR lamp on the indoor unit is flashing on and off to indicate an abnormality. To make sure, check how many times the abnormality indication is flashing on and off before starting service work.
- 2) If the electronic control P.C. board is supposed to be defective, check the copper foil pattern for disconnection and the components for bursting and discoloration.
- 3) When troubleshooting, refer to the flow chart on page 25 and the check table on page 26.

11-2. Instruction of troubleshooting

MUH-A07YV -^[E1]

MUH-A09YV -^[E1]

MUH-A12YV -^[E1]

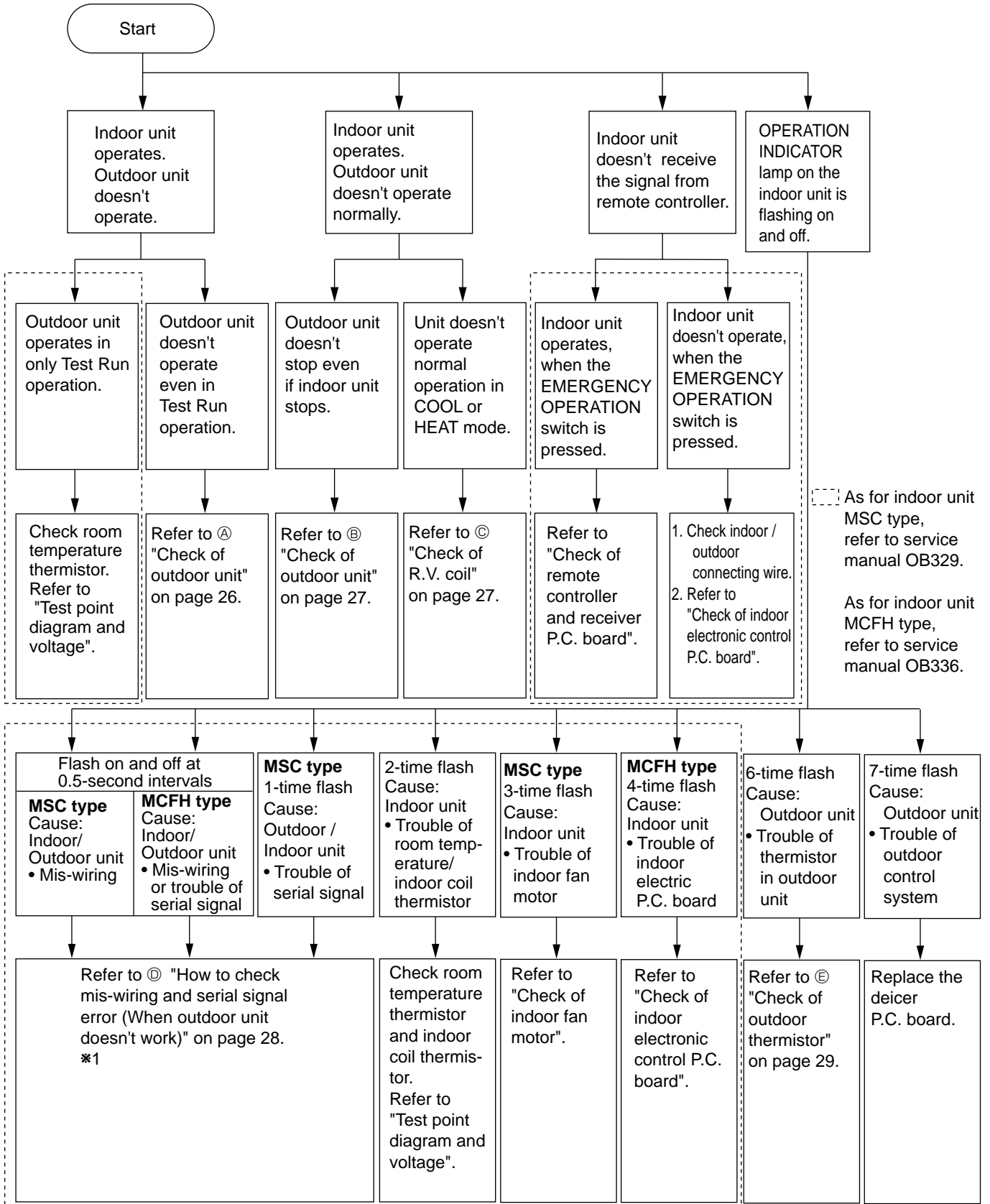

*1.<The case of the trouble of the serial signal>

When the power is turned off and then turned on again, the indication shows "the trouble of mis-wiring".

11-3. Trouble criterion of main parts

MUH-A07YV -[E1] **MUH-A09YV** -[E1] **MUH-A12YV** -[E1]

Part name	Check method and criterion	Figure																		
Defrost thermistor (RT63)	<p>Measure the resistance with a tester. (Part temperature -10°C ~ 40°C)</p> <table border="1"> <tr> <td>Normal</td> <td>Abnormal</td> </tr> <tr> <td>5kΩ ~ 60kΩ</td> <td>Open or short-circuit</td> </tr> </table>	Normal	Abnormal	5kΩ ~ 60kΩ	Open or short-circuit															
Normal	Abnormal																			
5kΩ ~ 60kΩ	Open or short-circuit																			
Compressor (MC) INNER PROTECTOR MUH-A07/A09YV 150± 5°C OPEN 90±10°C CLOSE MUH-A12YV 155± 5°C OPEN 90±10°C CLOSE	<p>Measure the resistance between the terminals with a tester. (Coil wiring temperature -10°C ~ 40°C)</p> <table border="1"> <tr> <td></td> <td colspan="3">Normal</td> <td rowspan="3">Abnormal</td> </tr> <tr> <td></td> <td>MUH-A07YV</td> <td>MUH-A09YV</td> <td>MUH-A12YV</td> </tr> <tr> <td>C-R</td> <td>3.41~4.18Ω</td> <td>2.99~3.67Ω</td> <td>2.46~3.01Ω</td> </tr> <tr> <td>C-S</td> <td>5.41~6.63Ω</td> <td>4.02~4.92Ω</td> <td>2.96~3.63Ω</td> <td>Open or short-circuit</td> </tr> </table>		Normal			Abnormal		MUH-A07YV	MUH-A09YV	MUH-A12YV	C-R	3.41~4.18Ω	2.99~3.67Ω	2.46~3.01Ω	C-S	5.41~6.63Ω	4.02~4.92Ω	2.96~3.63Ω	Open or short-circuit	
	Normal			Abnormal																
	MUH-A07YV	MUH-A09YV	MUH-A12YV																	
C-R	3.41~4.18Ω	2.99~3.67Ω	2.46~3.01Ω																	
C-S	5.41~6.63Ω	4.02~4.92Ω	2.96~3.63Ω	Open or short-circuit																
Outdoor fan motor (MF) INNER PROTECTOR MUH-A07YV 130± 5°C OPEN 83±15°C CLOSE INNER FUSE MUH-A09/A12YV 145± 2°C CUT OFF	<p>Measure the resistance between the terminals with a tester. (Coil wiring temperature -10°C ~ 40°C)</p> <table border="1"> <tr> <td rowspan="2">Color of lead wire</td> <td colspan="2">Normal</td> <td rowspan="2">Abnormal</td> </tr> <tr> <td>MUH-A07YV</td> <td>MUH-A09/A12YV</td> </tr> <tr> <td>WHT-BLK</td> <td>361 ~ 443Ω</td> <td>196 ~ 241Ω</td> <td rowspan="2">Open or short-circuit</td> </tr> <tr> <td>BLK-RED</td> <td>381 ~ 468Ω</td> <td>201 ~ 246Ω</td> </tr> </table>	Color of lead wire	Normal		Abnormal	MUH-A07YV	MUH-A09/A12YV	WHT-BLK	361 ~ 443Ω	196 ~ 241Ω	Open or short-circuit	BLK-RED	381 ~ 468Ω	201 ~ 246Ω	<p>MUH-A07YV</p> <p>MUH-A09/A12YV</p>					
Color of lead wire	Normal		Abnormal																	
	MUH-A07YV	MUH-A09/A12YV																		
WHT-BLK	361 ~ 443Ω	196 ~ 241Ω	Open or short-circuit																	
BLK-RED	381 ~ 468Ω	201 ~ 246Ω																		

Ⓟ INNER PROTECTOR

Compressor and/or outdoor fan motor doesn't operate.

A Check of outdoor unit

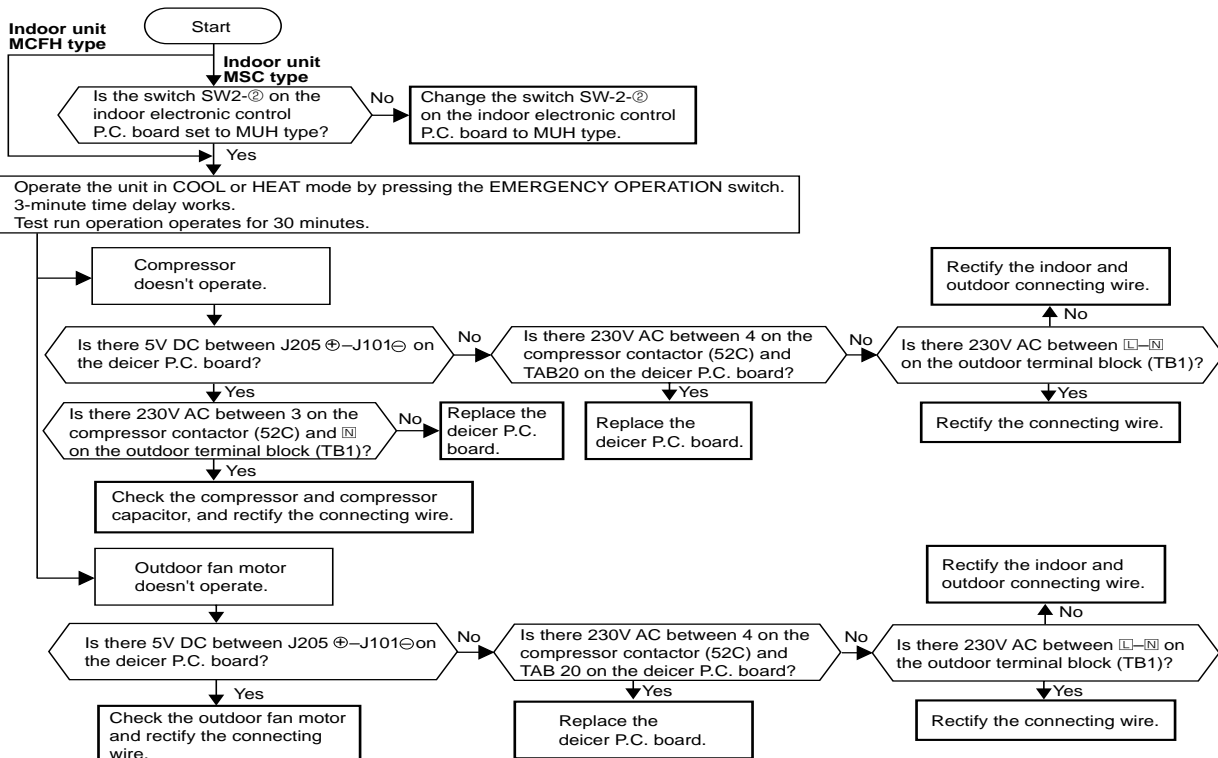

Compressor and/or outdoor fan motor doesn't stop.

Ⓑ Check of outdoor unit

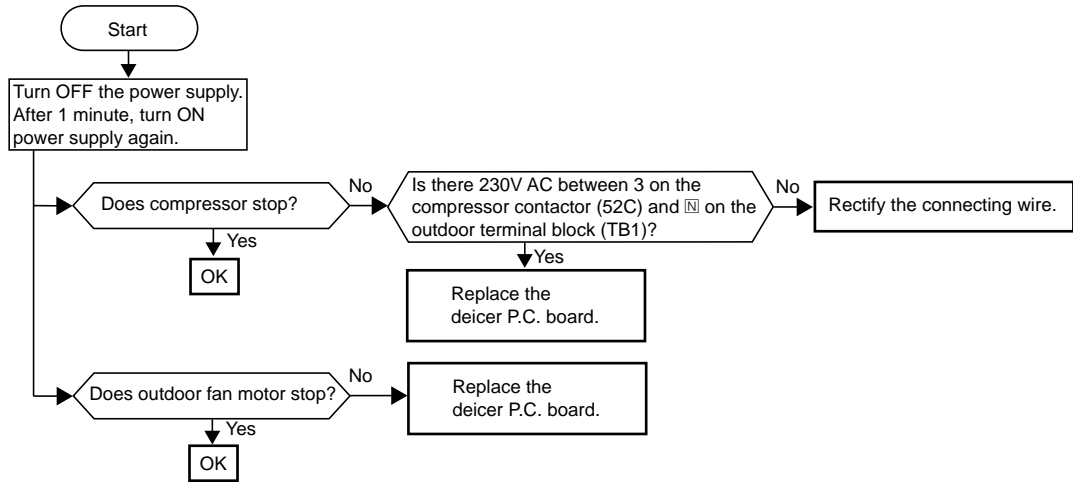

Unit operates COOL mode even if it is set to HEAT mode.

* First, measure the resistance of R.V. coil to confirm it is disconnected or is not short-circuit.

Ⓒ Check of R.V. coil

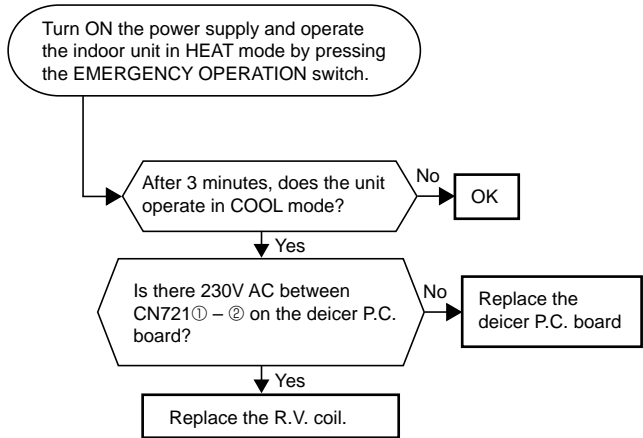

Unit operates HEAT mode even if it is set to COOL mode.

* First, measure the resistance of R.V. coil to confirm it is disconnected or is not short-circuit.

Ⓒ Check of R.V. coil

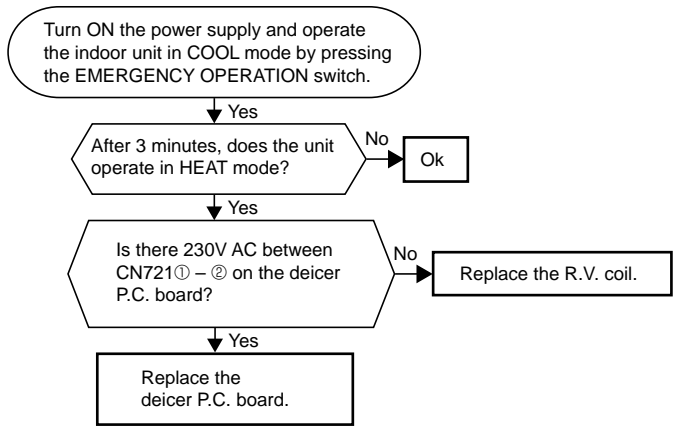

When OPERATION INDICATOR lamp flashes 0.5-second intervals or 1-time.
Outdoor unit does not operate.

① How to check mis-wiring and serial signal error

Example
Indoor unit MSC type

※ 1 Set the switch(SW2-②) on indoor electronic control P.C. board to MU or MUX type, when the outdoor unit is MU or MUX type. If the setting is MUH or MXZ type, the unit does not work.

※ 2 Short circuit of JPG and JPS on the indoor electronic control P.C. board enables self-check to be displayed in 3 seconds.

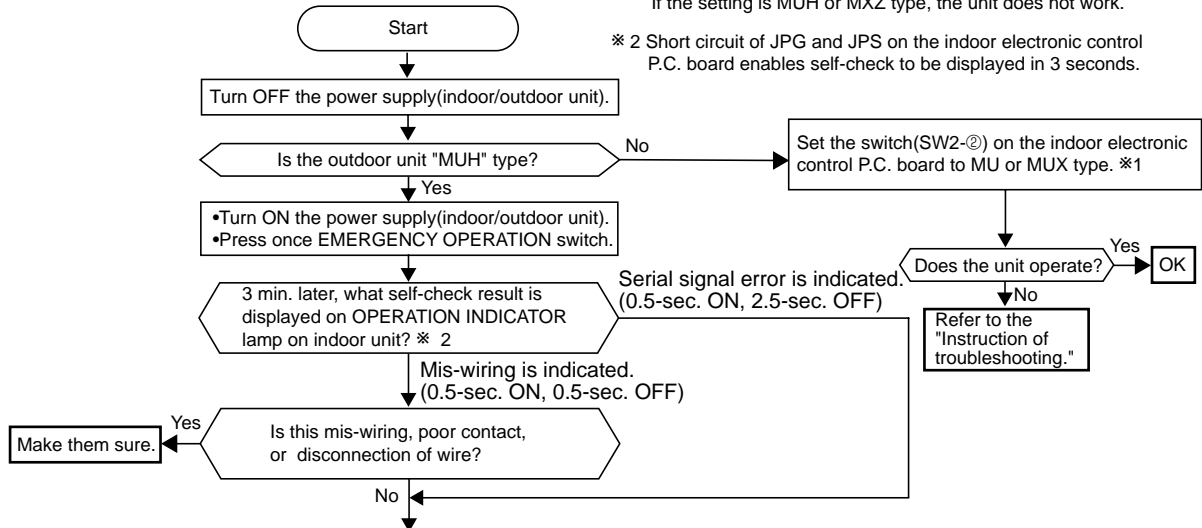

1. Turn OFF the power supply(indoor/outdoor unit) and disconnect indoor and outdoor connecting wire on indoor side.
2. Short-circuit between indoor terminal block [N] and [3].
3. Turn ON the power supply(indoor unit) and press once EMERGENCY OPERATION switch.

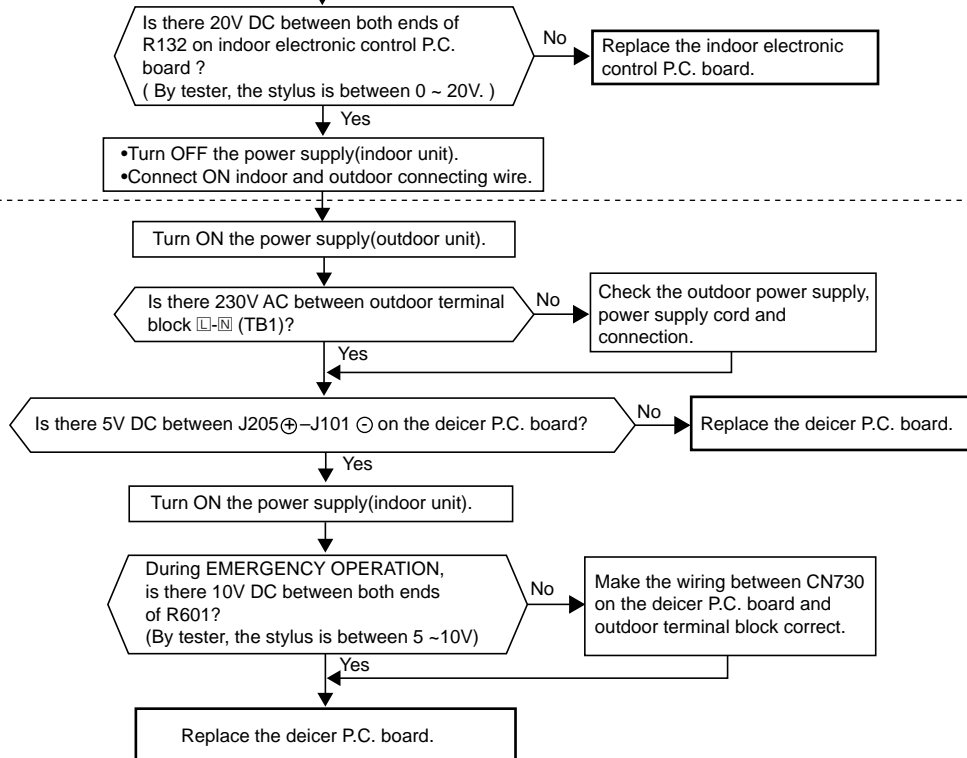

As for indoor unit MSC type, refer to service manual OB329.
As for indoor unit MCFH type, refer to service manual OB336.

When OPERATION INDICATOR lamp flashes 6-time.
Thermistors in the outdoor unit are abnormal.

Ⓔ Check of outdoor thermistor

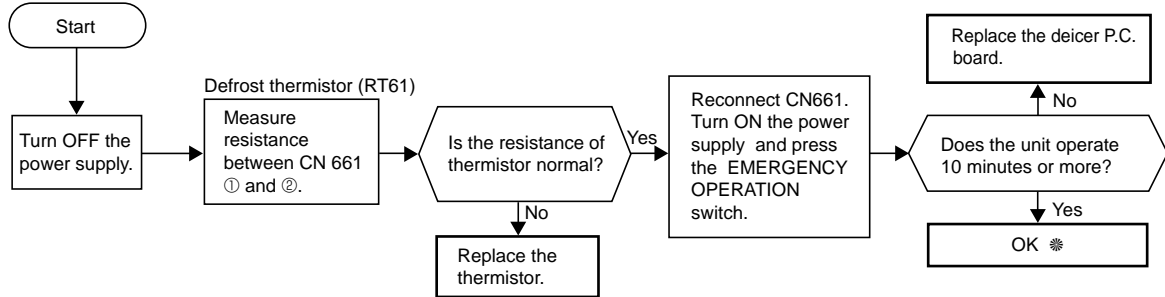

* Defective contact of the connector is considered.

MUH-A07YV -E1
MUH-A09YV -E1
MUH-A12YV -E1
Outdoor deicer P.C. board

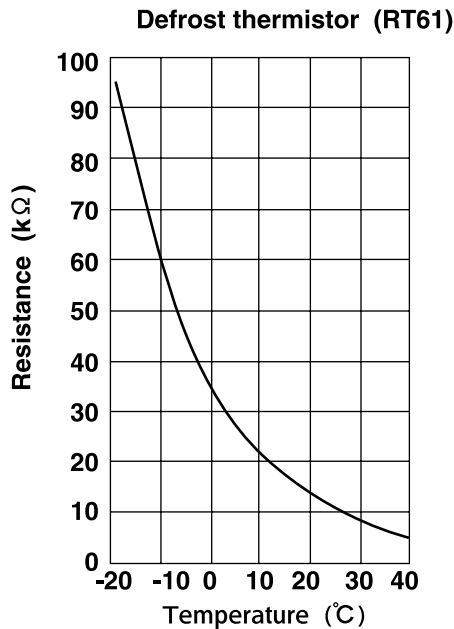
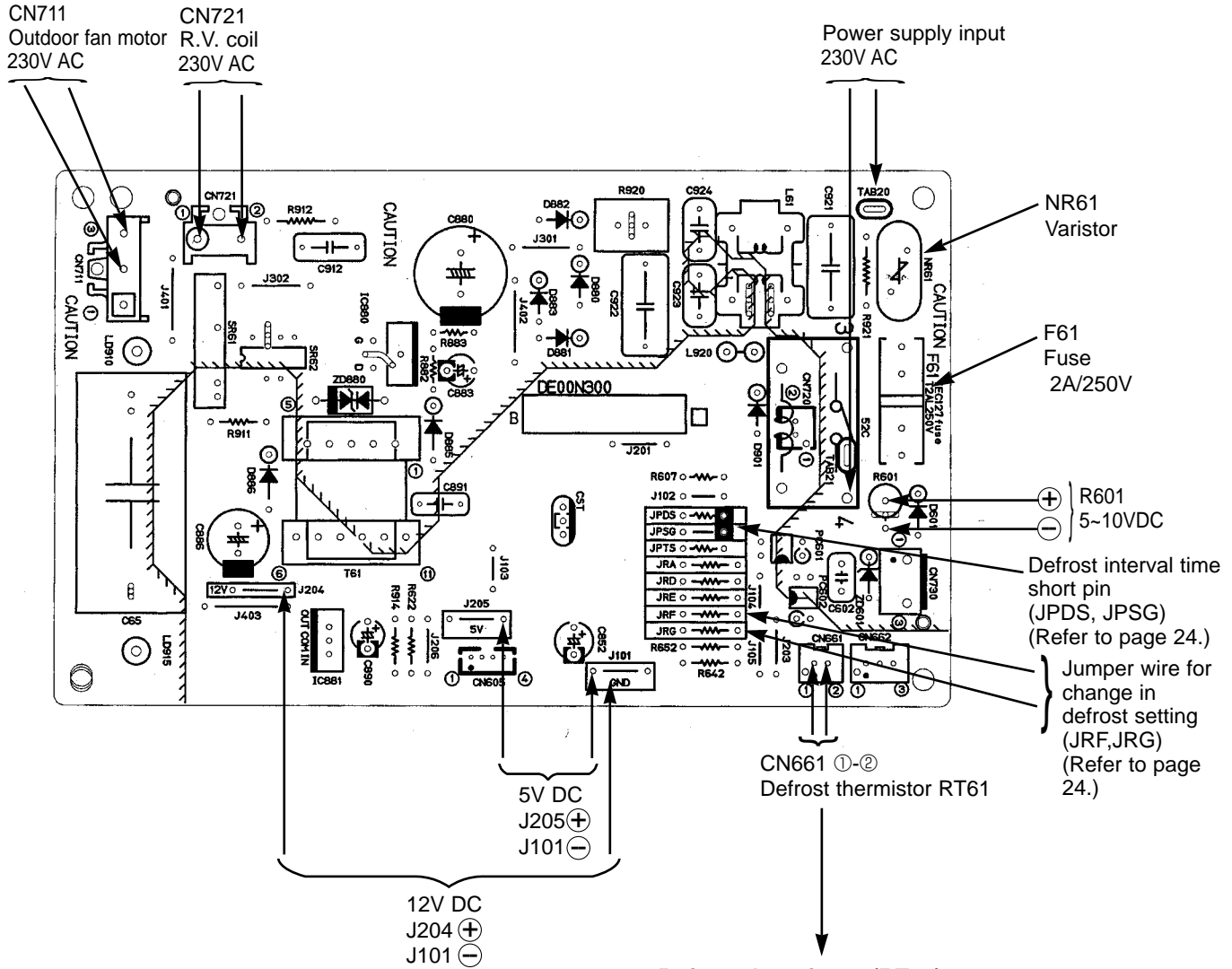

<"Terminal with lock mechanism" Detaching points>

In case of terminal with lock mechanism, detach the terminal as shown below.
There are two types (Refer to (1) and (2)) of the terminal with lock mechanism.
The terminal with no lock mechanism can be removed by pulling it out.
Check the shape of the terminal and work.

(1) Slide the sleeve and check if there is a locking lever or not.

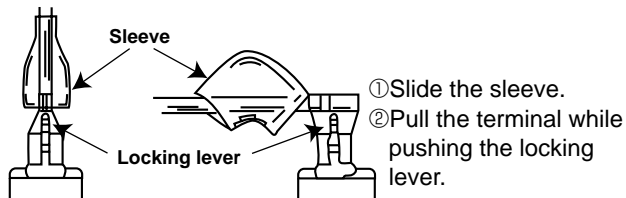

(2) The terminal with this connector is a terminal with lock mechanism

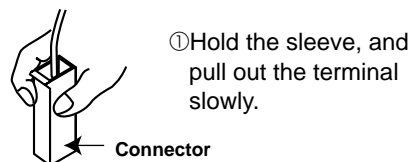

MUH-A07YV -[E1] MUH-A09YV -[E1] MUH-A12YV -[E1]
OUTDOOR UNIT

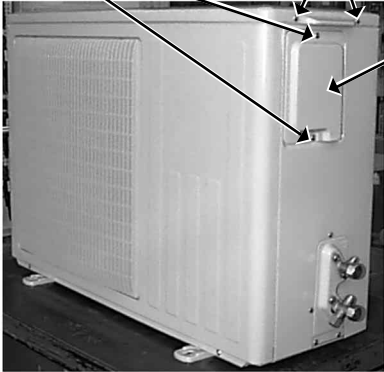
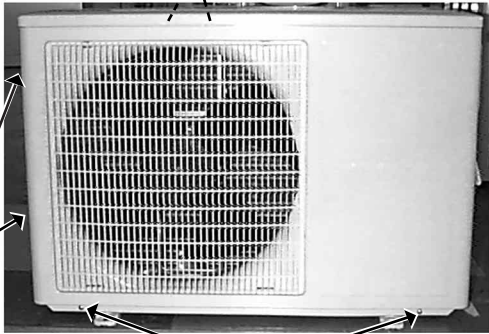
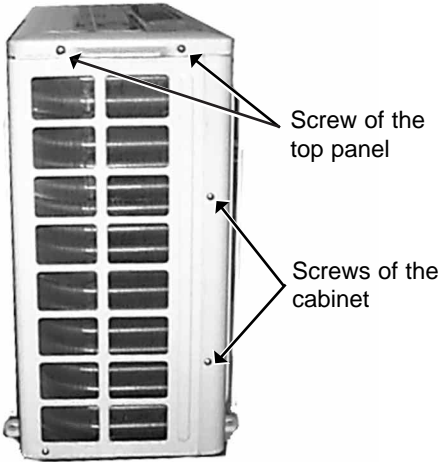
OPERATING PROCEDURE	PHOTOS
<p>1. Removing the cabinet</p> <ol style="list-style-type: none"> (1) Remove the screws of the top panel. (2) Remove the screw of the service panel. (3) Remove the screws of the cabinet. (4) Remove the screws of the front panel and motor support. (5) Remove the service panel, and remove the screw from the insides. (6) Remove the top panel. (7) Remove the cabinet. <p>Photo 3</p> 	<p>Photo 1</p>  <p>Photo 2</p> 

OPERATING PROCEDURE

2. Removing the deicer P.C. board

- (1) Remove the service panel and the cabinet.
- (2) Disconnect all the connectors and the terminals on the deicer P.C. board.
- (3) Remove the deicer P.C. board.

3. Removing the propeller and the outdoor fan motor

- (1) Remove the cabinet. (Refer to 1.)
- (2) Remove the propeller nut.
- (3) Remove the propeller.

NOTE : Loose the propeller in the rotating direction for removal.

When attaching the propeller, align the mark on the propeller and the motor shaft cut section.

Set the propeller in position by using the cut on the shaft and the mark on the propeller.

- (4) Remove lead clamps and disconnect the outdoor fan motor connector.
- (5) Remove screws fixing the fan motor.
- (6) Remove the outdoor fan motor.

PHOTOS

Photo 4

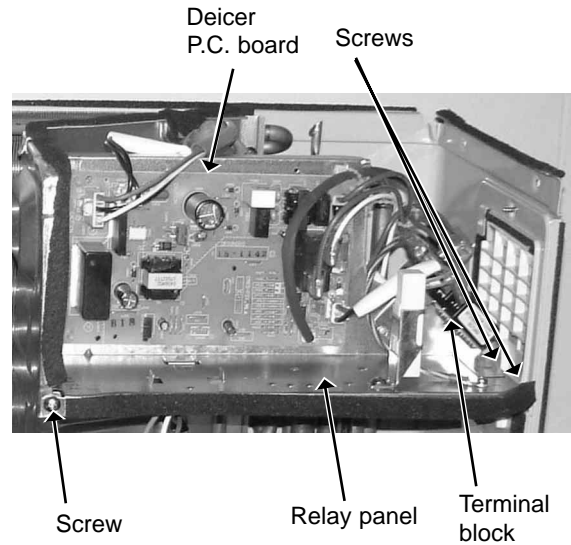
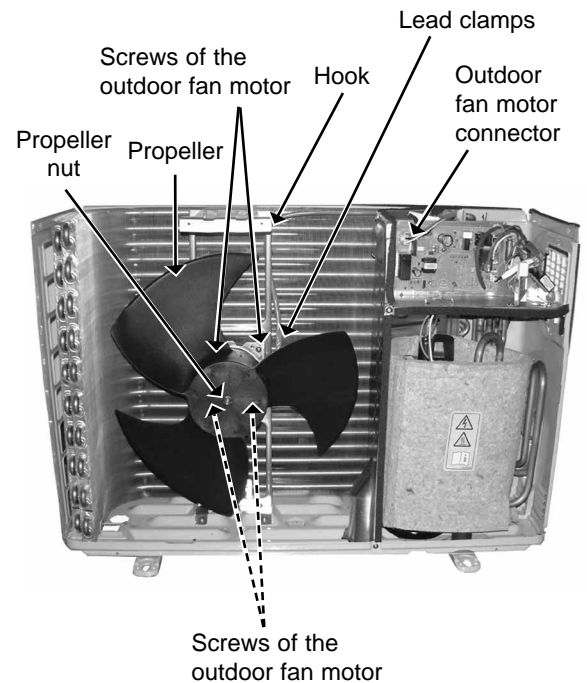
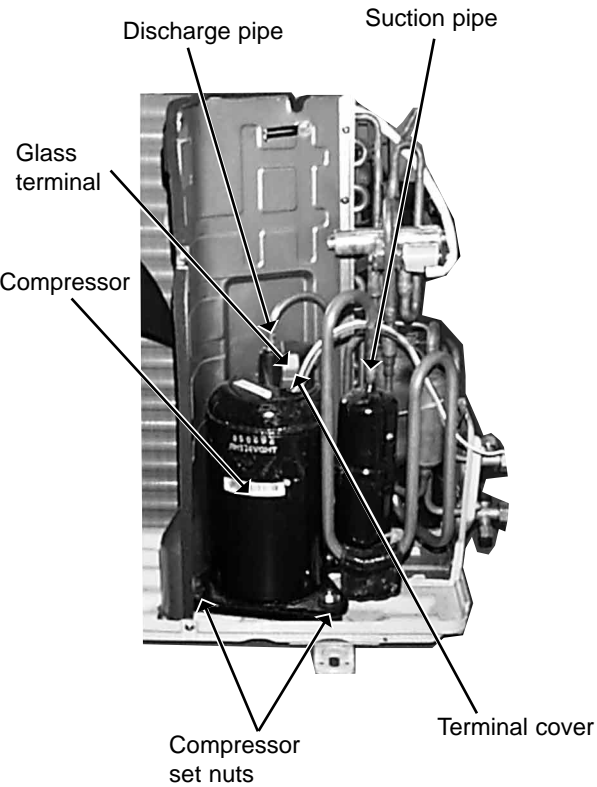

Photo 5





OPERATING PROCEDURE	PHOTOS
<p>4. Removing the compressor</p> <ol style="list-style-type: none">(1) Remove the cabinet. (Refer to 1.)(2) Remove the relay panel.(3) Remove the soundproof felt.(4) Remove the terminal cover on the compressor.(5) Disconnect lead wires from the glass terminal of the compressor.(6) Recover gas from the refrigerant circuit.(7) Disconnect the welded part of the discharge pipe.(8) Disconnect the welded part of the suction pipe.(9) Remove nuts fixing the compressor.(10) Remove the compressor. <p>NOTE</p> <ul style="list-style-type: none">● Before using a burner, reclaim gas from the pipes until the pressure gauge shows 0 kg/cm² (0 MPa).● Use the burner under the condition that gas can be recovered even when the inner pressure rises by heat.	<p>Photo 6</p>  <p>Discharge pipe</p> <p>Suction pipe</p> <p>Glass terminal</p> <p>Compressor</p> <p>Compressor set nuts</p> <p>Terminal cover</p>

MUH-A07YV -E1 MUH-A09YV -E1 MUH-A12YV -E1

13-1. OUTDOOR UNIT STRUCTURAL PARTS

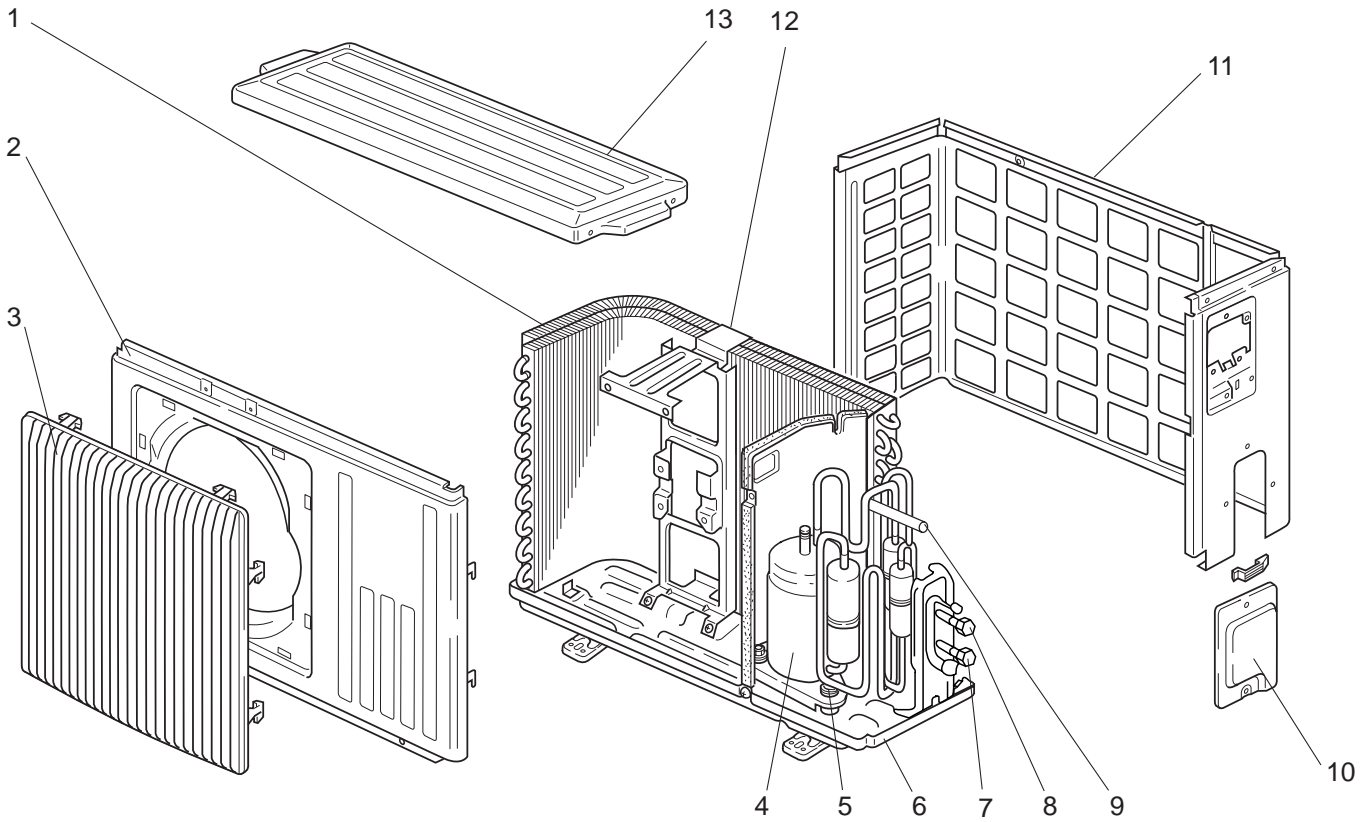

Part numbers that are circled are not shown in the illustration.

No.	Part No.	Part name	Symbol in Wiring Diagram	Q'ty/unit			Remarks
				MUH-A07YV- E1	MUH-A09YV- E1	MUH-A12YV- E1	
1	E02 835 630	OUTDOOR HEAT EXCHANGER		1			
	E02 836 630	OUTDOOR HEAT EXCHANGER			1		
	E02 837 630	OUTDOOR HEAT EXCHANGER				1	
2	E02 815 232	CABINET		1	1	1	
3	E02 815 521	GRILLE(OUT)		1	1	1	
4	E02 742 900	COMPRESSOR	MC	1			RN092VHSHT
	E02 753 900	COMPRESSOR	MC		1		RN104VHSHT
	E02 754 900	COMPRESSOR	MC			1	RN135VHSHT
5	E02 075 506	COMPRESSOR RUBBER SET		3	3	3	3RUBBERS/SET
6	E02 832 290	BASE		1	1	1	
7	E02 742 661	STOP VALVE(GAS)		1	1		φ9.52
	E02 747 661	STOP VALVE(GAS)				1	φ12.7
8	E02 745 662	STOP VALVE(LIQUID)		1	1	1	φ6.35
9	E02 745 961	4-WAY VALVE		1	1	1	
10	E02 815 245	SERVICE PANEL		1	1	1	
11	E02 836 233	BACK PANEL		1	1	1	
12	E02 336 515	MOTOR SUPPORT		1			
	E02 442 515	MOTOR SUPPORT			1	1	
13	E02 815 297	TOP PANEL		1	1	1	
⑭	E02 159 936	CAPILLARY TUBE		2			φ3.0xφ1.4x800
	E02 156 936	CAPILLARY TUBE		1	2	2	φ3.0xφ1.4x500
	E02 339 936	CAPILLARY TUBE		1	1		φ3.0xφ1.4x600
	E02 024 936	CAPILLARY TUBE			1		φ3.0xφ1.4x1000
	E02 726 936	CAPILLARY TUBE				1	φ3.0xφ1.6x600
	E02 837 936	CAPILLARY TUBE				1	φ3.0xφ1.6x1050
⑮	E02 154 642	CHECK VALVE		1	1	1	

MUH-A07YV -E1 MUH-A09YV -E1 MUH-A12YV -E1

13-2. OUTDOOR UNIT ELECTRICAL PARTS AND FUNCTIONAL PARTS

13-3. ACCESSORY

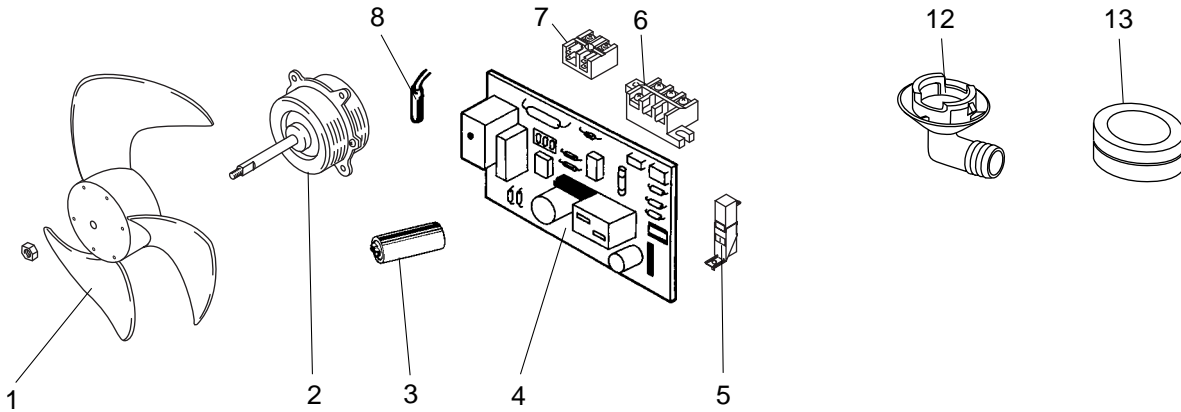

13-2. OUTDOOR UNIT ELECTRICAL PARTS AND FUNCTIONAL PARTS

Part numbers that are circled are not shown in the illustration.

No.	Part No.	Part name	Symbol in Wiring Diagram	Q'ty/unit			Remarks
				MUH-A07YV- E1	MUH-A09YV- E1	MUH-A12YV- E1	
1	E02 665 501	PROPELLER		1	1	1	
2	E02 835 301	OUTDOOR FAN MOTOR	MF	1			RC6V20-□□
	E02 672 301	OUTDOOR FAN MOTOR	MF		1	1	RA6V33-□□
3	E02 752 353	COMPRESSOR CAPACITOR	C1	1			20 μ F /440V AC
	E02 694 353	COMPRESSOR CAPACITOR	C1		1		25 μ F /440V AC
	E02 696 353	COMPRESSOR CAPACITOR	C1			1	30 μ F /440V AC
4	E02 835 451	DEICER P.C. BOARD		1			
	E02 836 451	DEICER P.C. BOARD			1	1	
5	E02 128 383	SURGE ABSORBER	DSAR	1	1	1	
6	E02 817 374	TERMINAL BLOCK	TB1	1	1	1	3P
7	E02 836 374	TERMINAL BLOCK	TB2	1	1	1	2P
8	E02 699 310	DEFROST THERMISTOR	RT61	1	1	1	
⑨	E02 440 490	R. V. COIL	21S4	1	1	1	
⑩	E02 095 382	FUSE	F61	1	1	1	250V 2A
⑪	E02 820 385	VARISTOR	NR61	1	1	1	

13-3. ACCESSORY

12	E02 817 704	DRAIN SOCKET		1	1	1	
13	E02 440 705	DRAIN CAP		2	2	2	2PCS/SET



HEAD OFFICE: MITSUBISHI DENKI BLDG.,2-2-3, MARUNOUCHI, CHIYODA-KU, TOKYO100-8310, JAPAN

© Copyright 2003 MITSUBISHI ELECTRIC ENGINEERING CO.,LTD
Distributed in Feb. 2004. No.OB331 REVISED EDITION-A 6
Distributed in Dec. 2003. No.OB331 6
Made in Japan

New publication, effective Feb. 2004
Specifications subject to change without notice.