

SERVICE MANUAL

Wireless type Models

MSZ-A09YV - [E1] (WH)

MSZ-A12YV - [E1] (WH)

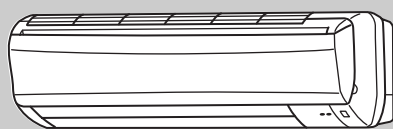

Indication of model name

MSZ-A09YV - [E1]

MSZ-A12YV - [E1]



CONTENTS

1. PART NAMES AND FUNCTIONS.....	2
2. SPECIFICATION.....	4
3. NOISE CRITERIA CURVES.....	5
4. OUTLINES AND DIMENSIONS	6
5. WIRING DIAGRAM	7
6. REFRIGERANT SYSTEM DIAGRAM	7
7. SERVICE FUNCTIONS	8
8. TROUBLESHOOTING.....	10
9. DISASSEMBLY INSTRUCTIONS	19
10. PARTS LIST.....	21
11. OPTIONAL PARTS.....	23

NOTE:

This service manual describes technical data of the indoor units.

•Refer to the service manual OB328 when MSZ-A09YV-[E1] or MSZ-A12YV-[E1] is connected with MUZ-A09YV-[E1], MUZ-A12YV-[E1], MUZ-A09YVH-[E1] or MUZ-A12YVH-[E1].

•Refer to the service manual OB319 when MSZ-A09YV-[E1] or MSZ-A12YV-[E1] is connected with MXZ-A18WV-[E1], MXZ-A26WV-[E1] or MXZ-A32WV-[E1] as multi system units.



1

PART NAMES AND FUNCTIONS

INDOOR UNIT

MSZ-A09YV - [E1]

MSZ-A12YV - [E1]

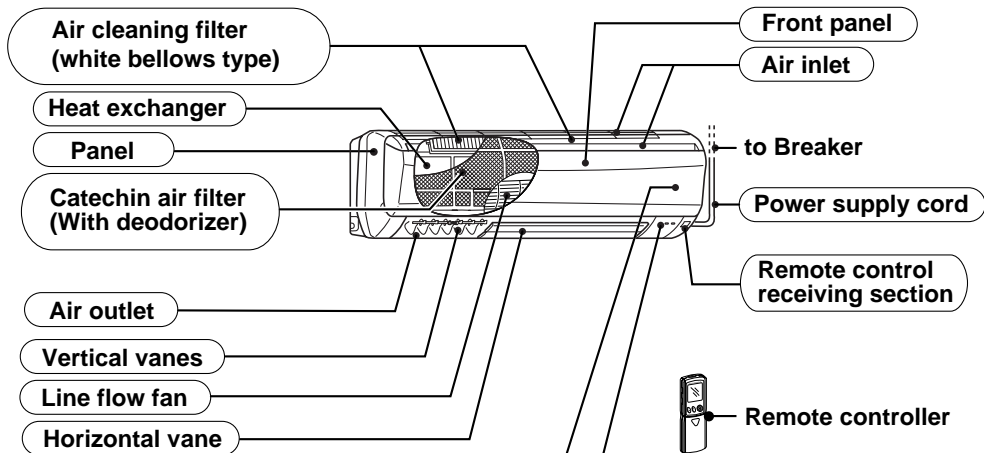

Operation section
(When the front panel is opened)

Display section

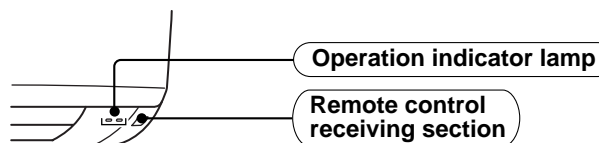

ACCESSORIES

INDOOR UNIT

		MSZ-A09YV - [E1] MSZ-A12YV - [E1]
①	Installation plate	1
②	Installation plate fixing screw 4 × 25 mm	5
③	Remote controller holder	1
④	Fixing screw for ③ 3.5 × 1.6 mm (Black)	2
⑤	Battery (AAA) for remote controller	2
⑥	Wireless remote controller	1
⑦	Felt tape (Used for left or left-rear piping)	1

MSZ-A09YV -E1
 MSZ-A12YV -E1

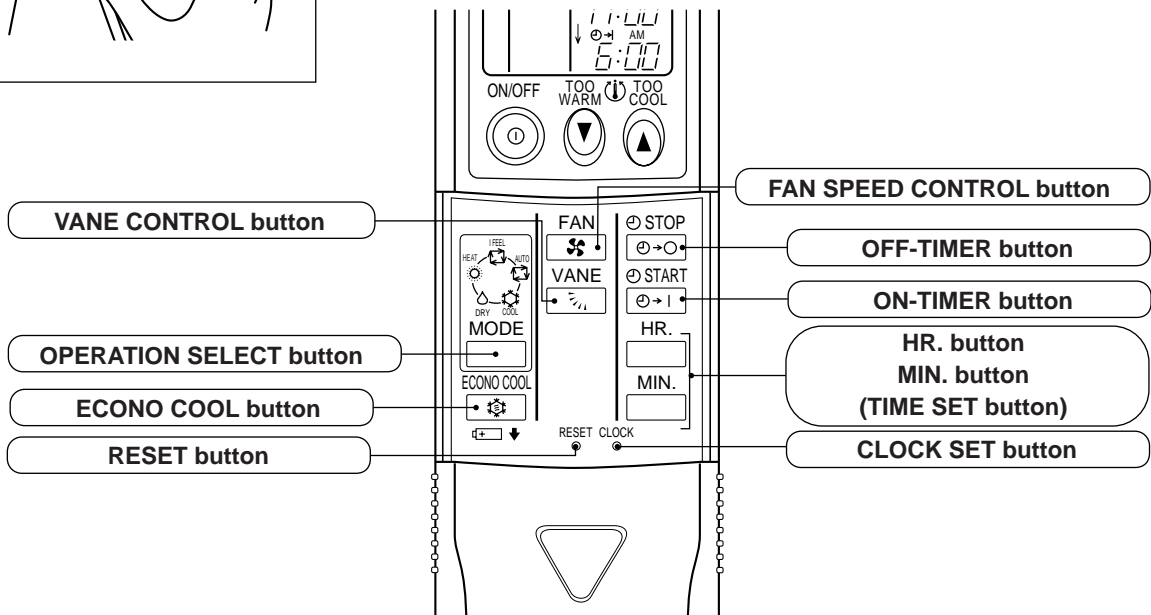
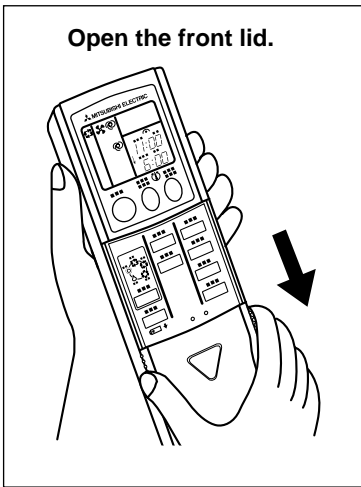
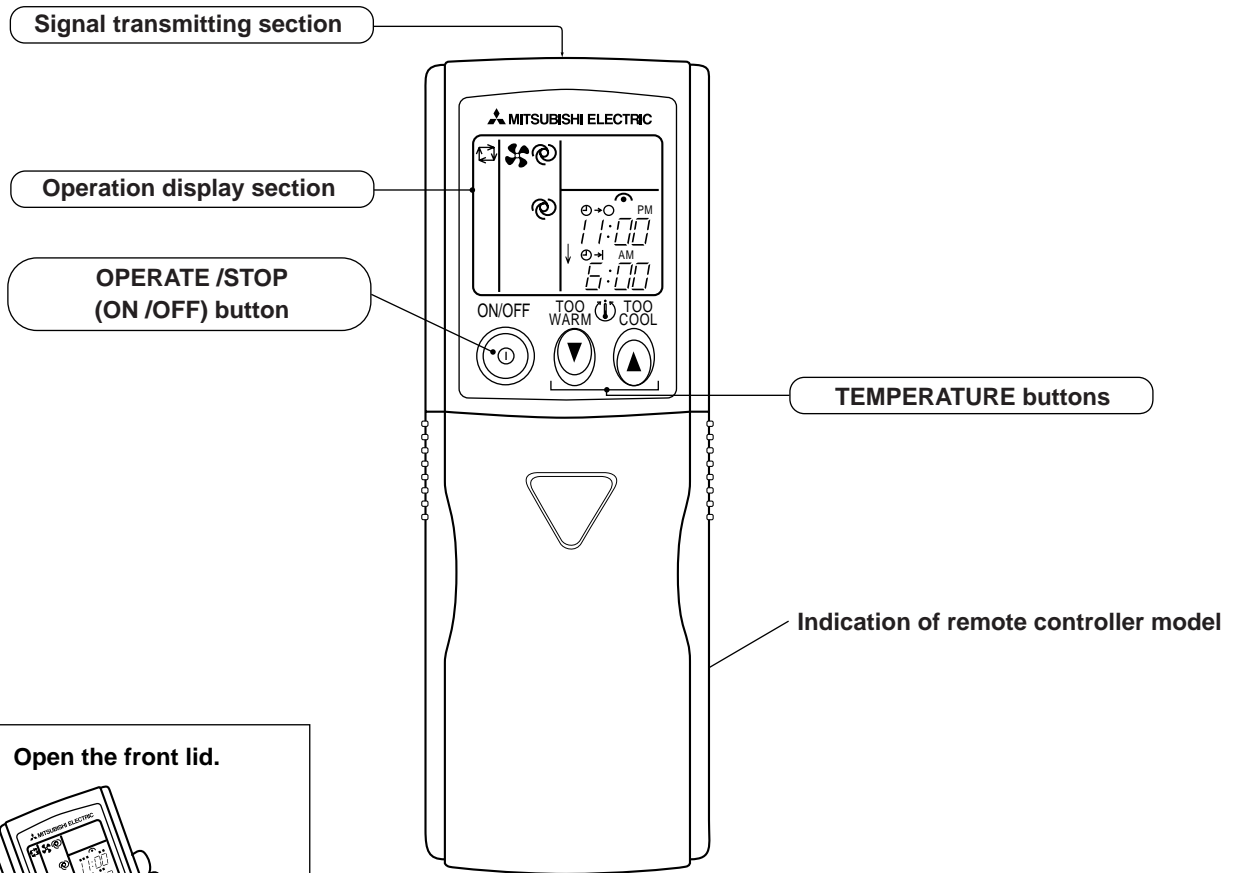

Indoor model			MSZ-A09YV - E1		MSZ-A12YV - E1	
Function			Cooling	Heating	Cooling	Heating
Power supply			Single phase 230V,50Hz		Single phase 230V,50Hz	
Capacity	Air flow(High/Med.*/Low*)	m ³ /h	504/360*/222*	564/402*/246*	630/462*/288*	642/474*/312*
Electrical data	Power outlet	A	10		10	
	Running current *1	A	0.17		0.19	
	Power input Rated frequency	W	35		40	
	Auxiliary heater	A(kW)	—		—	
	Power factor *1	%	88	94	95	94
	Fan motor current *1	A	0.17		0.19	
Fan motor	Model		RC4V19-LA		RC4V19-KA	
	Winding resistance(at20°C)	Ω	WHT-BLK 413 BLK-RED 334		WHT-BLK 316 BLK-RED 299	
	Dimensions W×H×D	mm	815×278×244		815×278×244	
	Weight	kg	9		10	
Special remarks	Air direction		5		5	
	Sound level(High/Med.*/Low*)	dB(A)	37/29*/21*	38/30*/21*	39/31*/22*	38/30*/22*
	Fan speed(High/Med.*/Low*)	rpm	1,010/770*/540*	1,110/840*/580*	1,030/800*/570*	1,050/820*/600*
	Fan speed regulator		3		3	
	Thermistor RT11(at25°C)	kΩ	10		10	
	Thermistor RT12(at25°C)	kΩ	10		10	
	Thermistor RT13(at25°C)	kΩ	10		10	
	Remote controller model		KG04A		KG04A	

NOTE : Test conditions are based on ISO 5151

Cooling : Indoor DB27°C WB19°C

Outdoor DB35°C WB 24°C

Heating : Indoor DB 20°C WB15°C

Outdoor DB 7°C WB 6°C

Refrigerant piping length (one way): 5m

* Reference value

*1 Measured under rated operating frequency.

Specifications and rating conditions of main electric parts

INDOOR UNIT

Item	Model	MSZ-A09YV - E1 MSZ-A12YV - E1
Indoor fan capacitor	(C11)	1.5μF 440V
Fuse	(F11)	250V 3.15A
Thermal fuse	(F12)	93°C 5A 250V
Vane motor	(MV)	MSBPC20 12V 250Ω
Varistor	(NR11)	ERZV10D471
Solid state relay	(SR141)	S201DH1Y
Terminal block	(TB)	5P
Contactors	(52C)	JM1aN-ZTMP-DC12V
Indoor fan motor thermal fuse		136°C ±3°C 2A

3

NOISE CRITERIA CURVES

MSZ-A09YV -[E1]

FAN SPEED	FUNCTION	SPL(dB(A))	LINE
High	COOLING	37	●—●
	HEATING	38	○—○

Test conditions,

Cooling : Dry-bulb temperature 27°C Wet-bulb temperature 19°C
 Heating : Dry-bulb temperature 20°C Wet-bulb temperature 15°C

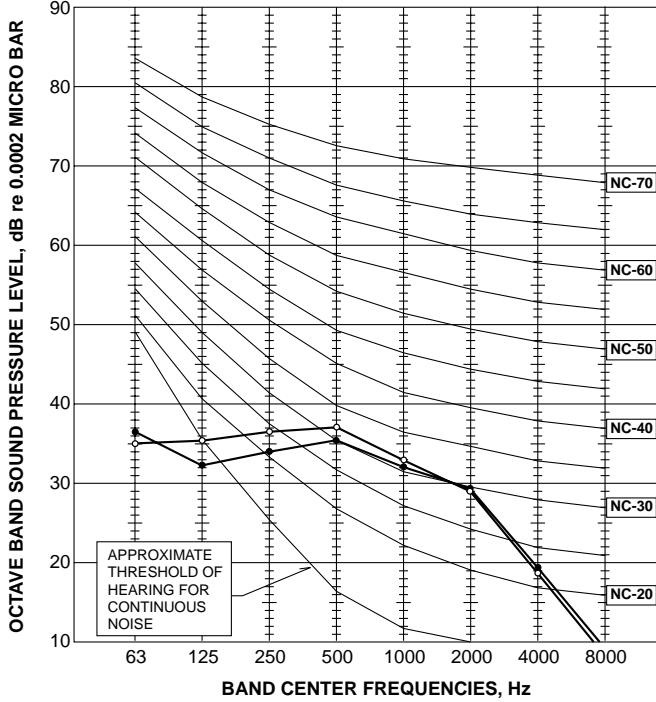

MSZ-A12YV -[E1]

FAN SPEED	FUNCTION	SPL(dB(A))	LINE
High	COOLING	39	●—●
	HEATING	38	○—○

Test conditions,

Cooling : Dry-bulb temperature 27°C Wet-bulb temperature 19°C
 Heating : Dry-bulb temperature 20°C Wet-bulb temperature 15°C

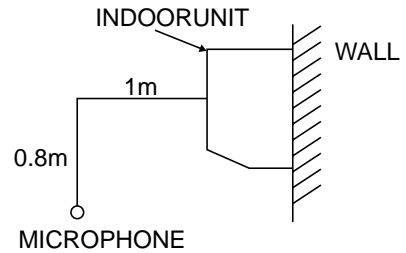
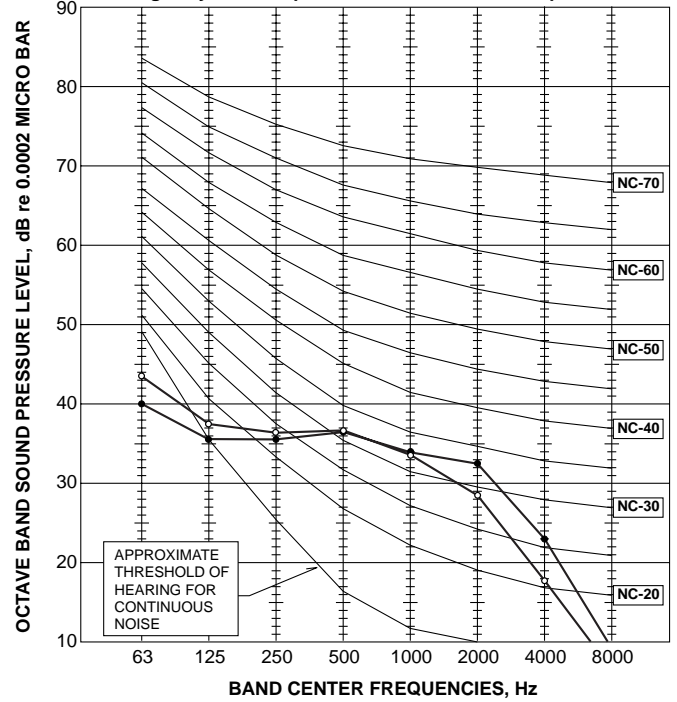

4

OUTLINES AND DIMENSIONS

MSZ-A09YV - [E1]

Unit : mm

INDOOR UNIT

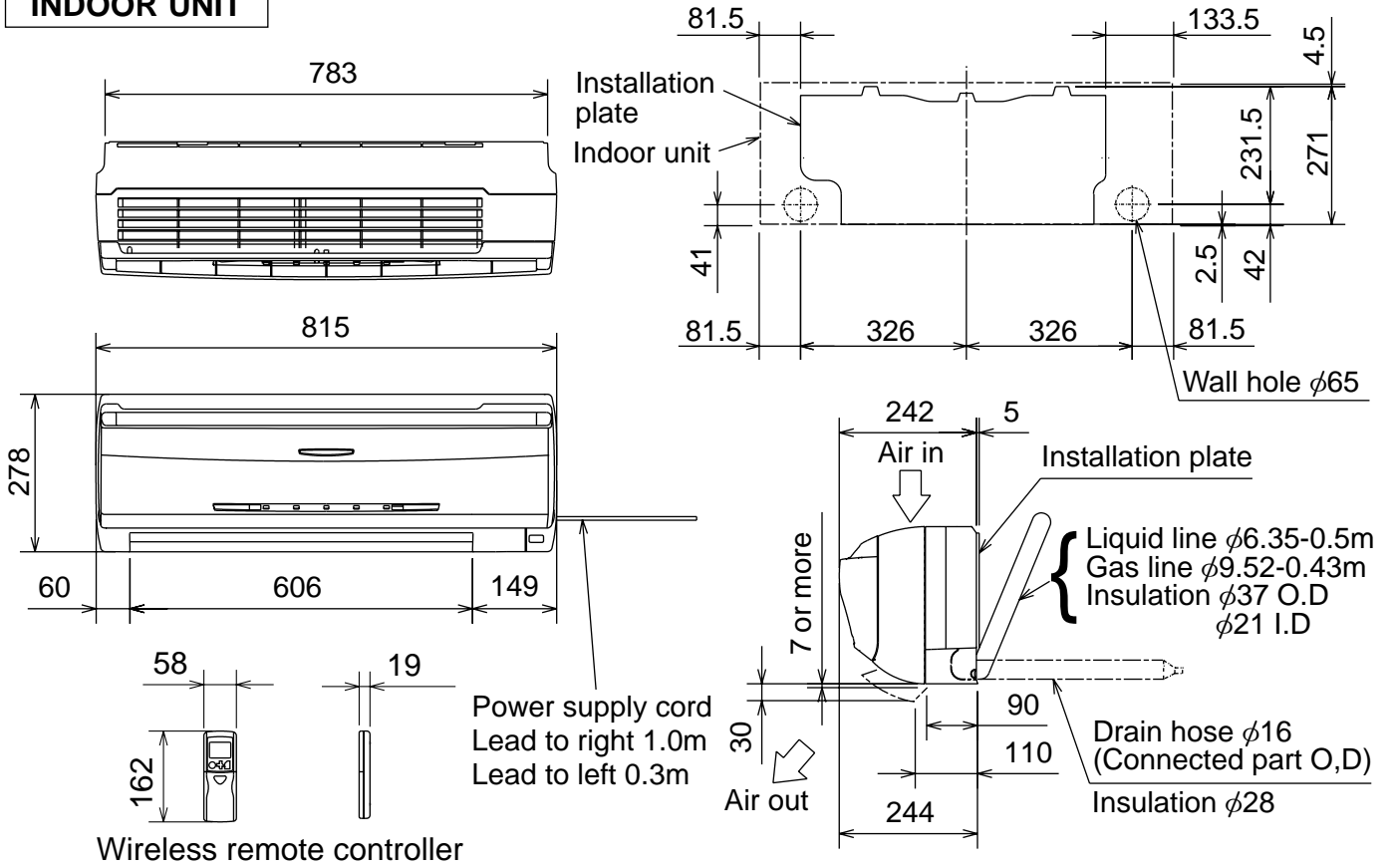

MSZ-A12YV - [E1]

Unit : mm

INDOOR UNIT

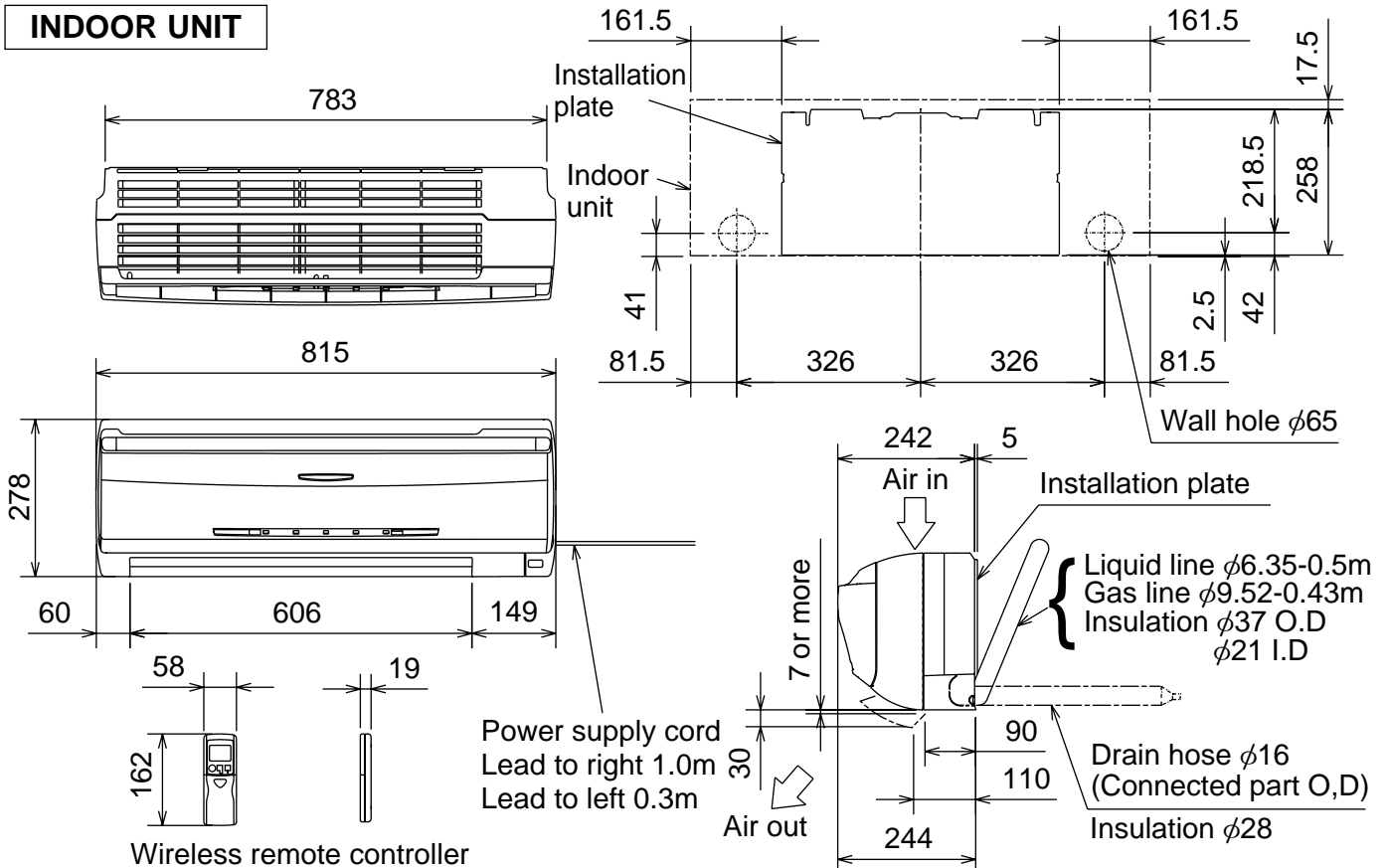

5

WIRING DIAGRAM

MSZ-A09YV -[E1]

MSZ-A12YV -[E1]

MODELS WIRING DIAGRAM

INDOOR UNIT

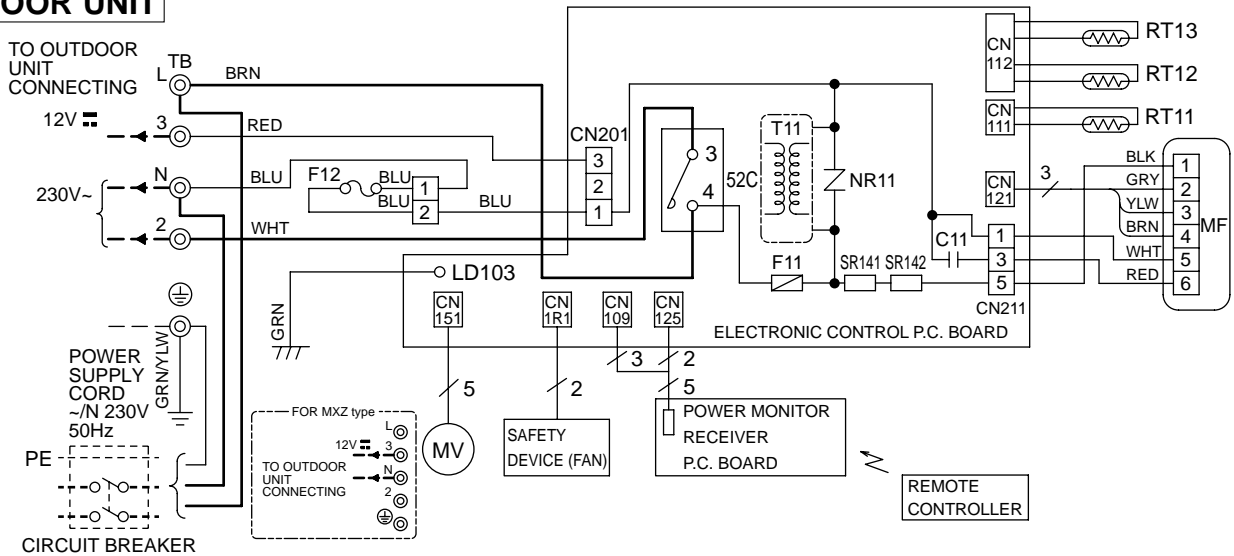

SYMBOL	NAME	SYMBOL	NAME	SYMBOL	NAME
C11	INDOOR FAN CAPACITOR	NR11	VARIATOR	SR142	SOLID STATE RELAY
F11	FUSE (3.15A)	RT11	ROOM TEMPERATURE THERMISTOR	T11	TRANSFORMER
F12	THERMAL FUSE (93°C)	RT12	INDOOR COIL THERMISTOR (MAIN)	TB	TERMINAL BLOCK
MF	INDOOR FAN MOTOR (INNER FUSE)	RT13	INDOOR COIL THERMISTOR (SUB)	52C	CONTACTOR
MV	VANE MOTOR	SR141	SOLID STATE RELAY		

NOTE: 1. About the outdoor side electric wiring refer to the outdoor unit electric wiring diagram for servicing.
 2. Use copper conductors only. (For field wiring)
 3. Symbols below indicate.
 ○: Terminal block, □: Connector

6

REFRIGERANT SYSTEM DIAGRAM

MSZ-A09YV -[E1]

MSZ-A12YV -[E1]

Unit:mm

INDOOR UNIT

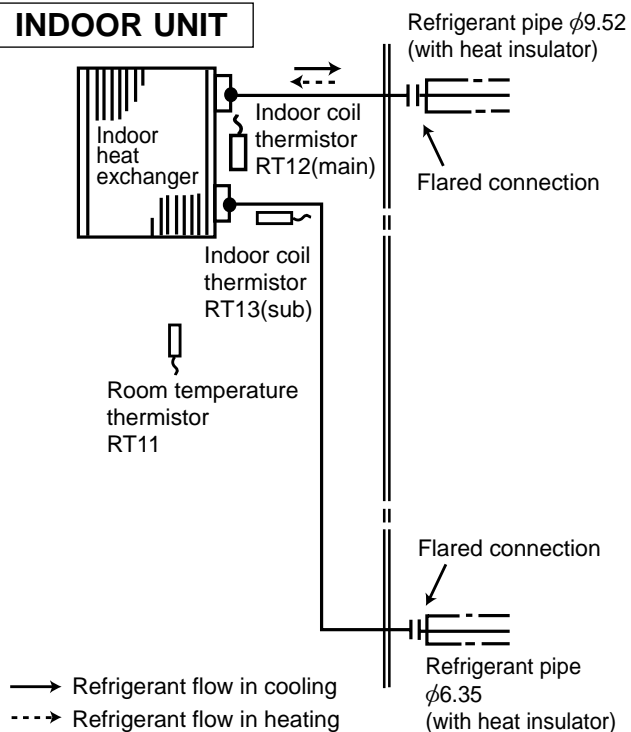

INDOOR UNIT

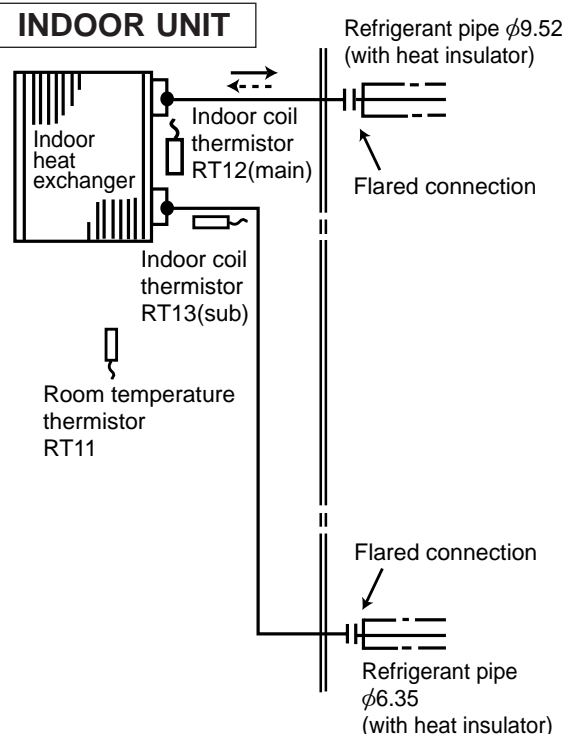

→ Refrigerant flow in cooling
 --- Refrigerant flow in heating

MSZ-A09YV -[E1]

MSZ-A12YV -[E1]

7-1. TIMER SHORT MODE

For service, set time can be shortened by short circuit of JPG and JPS the electronic control P.C. board.

The time will be shortened as follows. (Refer to page 18.)

Set time : 1-minute → 1-second

Set time : 3-minute → 3-second (It takes 3 minutes for the compressor to start operation. However, the starting time is shortened by short circuit of JPG and JPS.)

7-2. P.C. BOARD MODIFICATION FOR INDIVIDUAL OPERATION

A maximum of 4 indoor units with wireless remote controllers can be used in a room.

In this case, to operate each indoor unit individually by each remote controller, P.C. boards of remote controller must be modified according to the number of the indoor unit.

How to modify the remote controller P.C. board

Remove batteries before modification.

The board has a print as shown below :

Remote controller model : KG04A

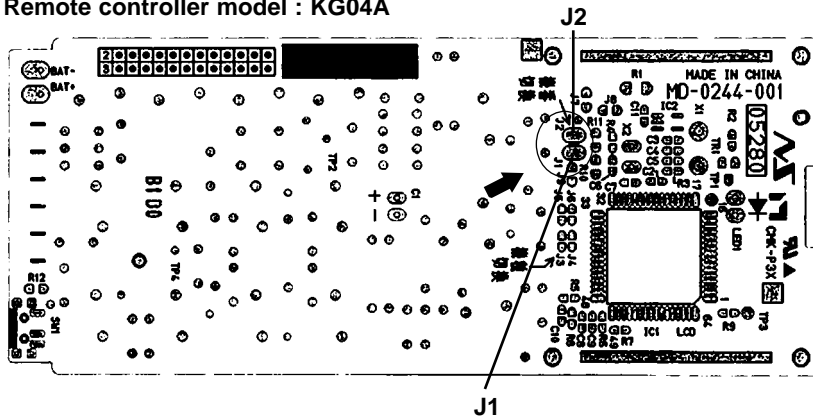

NOTE : For remodelling, take out the batteries and press the OPERATE/STOP(ON/OFF) button twice or 3 times at first.

After finish remodelling, put back the batteries then press the RESET button.

The P.C. board has the print "J1" and "J2". Solder "J1" and "J2" according to the number of indoor unit as shown in Table 1.

After modification, press the RESET button.

Table 1

	1 unit operation	2 units operation	3 units operation	4 units operation
No. 1 unit	No modification	Same as at left	Same as at left	Same as at left
No. 2 unit	—	Solder J1	Same as at left	Same as at left
No. 3 unit	—	—	Solder J2	Same as at left
No. 4 unit	—	—	—	Solder both J1 and J2

How to set the remote controller exclusively for particular indoor unit.

After you turn the breaker ON, the first remote controller that sends the signal to the indoor unit will be regarded as the remote controller for the indoor unit.

The indoor unit will only accept the signal from the remote controller that has been assigned to the indoor unit once they are set.

The setting will be cancelled if the breaker has turned off, or the power supply has shut down.

Please conduct the above setting once again after the power has restored.

7-3. AUTO RESTART FUNCTION

When the indoor unit is controlled with the remote controller, the operation mode, the set temperature, and the fan speed are memorized by the indoor electronic control P.C. board. The "AUTO RESTART FUNCTION" sets to work the moment power has restored after power failure. Then, the unit will restart automatically.

However if the unit is operated in "I FEEL CONTROL" mode before power failure,

the operation is not memorized. In "I FEEL CONTROL" mode, the operation is decided by the initial room temperature.

How to release “AUTO RESTART FUNCTION”

- ① Turn off the main power for the unit.
- ② Pull out the indoor electronic control P.C. board and the power monitor receiver P.C.board. (Refer to page 19.)
- ③ Solder the Jumper wire to the JR07 on the indoor electronic control P.C.board. (Refer to page 18.)

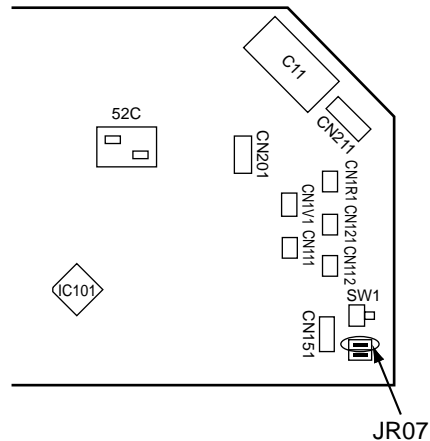

Operation

- ① If the main power (230V AC) has been cut, the operation settings remain.
- ② After the power is restored, the unit restarts automatically according to the memory. (However, it takes at least 3 minutes for the compressor to start running.)

NOTE:

- The operation settings are memorized when 10 seconds have passed after the indoor unit was operated with the remote controller.
- If main power is turned OFF or a power failure occurs while AUTO START/STOP timer is active, the timer setting is cancelled.
- If the unit has been off with the remote controller before power failure, the auto restart function does not work as the power button of the remote controller is off.
- To prevent breaker off due to the rush of starting current, systematize other home appliance not to turn on at the same time.
- When some air conditioners are connected to the same supply system, if they are operated before power failure, the starting current of all the compressors may flow simultaneously at restart. Therefore, the special counter-measures are required to prevent the main voltage-drop or the rush of the starting current by adding to the system that allows the units to start one by one.

MSZ-A09YV -[E1]

MSZ-A12YV -[E1]

8-1. Cautions on troubleshooting**1. Before troubleshooting, check the following:**

- 1) Check the power supply voltage.
- 2) Check the indoor/outdoor connecting wire for mis-wiring.

2. Take care the following during servicing.

- 1) Before servicing the air conditioner, be sure to first turn off the remote controller to stop the main unit, and then after confirming the horizontal vane is closed, turn off the breaker and / or disconnect the power plug.
- 2) Be sure to turn OFF the power supply before removing the front panel, the cabinet, the top panel, and the electronic control P.C. board.
- 3) When removing the electronic control P.C. board, hold the edge of the board with care NOT to apply stress on the components.
- 4) When connecting or disconnecting the connectors, hold the housing of the connector. DO NOT pull the lead wires.

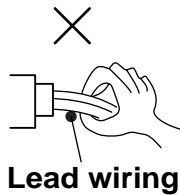
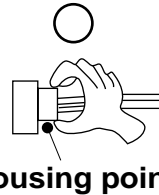
**Lead wiring****Housing point****3. Troubleshooting procedure**

- 1) First, check if the OPERATION INDICATOR lamp on the indoor unit is flashing on and off to indicate an abnormality. To make sure, check how many times the abnormality indication is flashing on and off before starting service work.
- 2) Before servicing check that the connector and terminal are connected properly.
- 3) If the electronic control P.C. board is supposed to be defective, check the copper foil pattern for disconnection and the components for bursting and discoloration.
- 4) When troubleshooting, refer to the flow chart on page 12 and the check table on page 13.

4. How to replace batteries

Weak batteries may cause the remote controller malfunction.

In this case, replace the batteries to operate the remote controller normally.

- ① Remove the front lid and insert batteries. Then reattach the front lid.

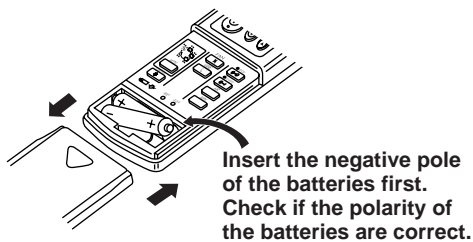

- ② Press the RESET button with tip end of ball point pen or the like, and then use the remote controller.

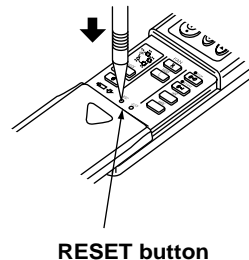

NOTE : 1. If the RESET button is not pressed, the remote controller may not operate correctly.

2. This remote controller has a circuit to automatically reset the microcomputer when batteries are replaced. This function is equipped to prevent the microcomputer from malfunctioning due to the voltage drop caused by the battery replacement.

5. How to install the horizontal vanes

If horizontal vanes are not installed correctly, both of the operation indicator lamps will flash.
In this case, install the horizontal vanes correctly by following the procedures ① to ⑥.

NOTE: Before installation of the horizontal vanes, disconnect the power supply plug and/ or turn off the breaker.

Upper vane

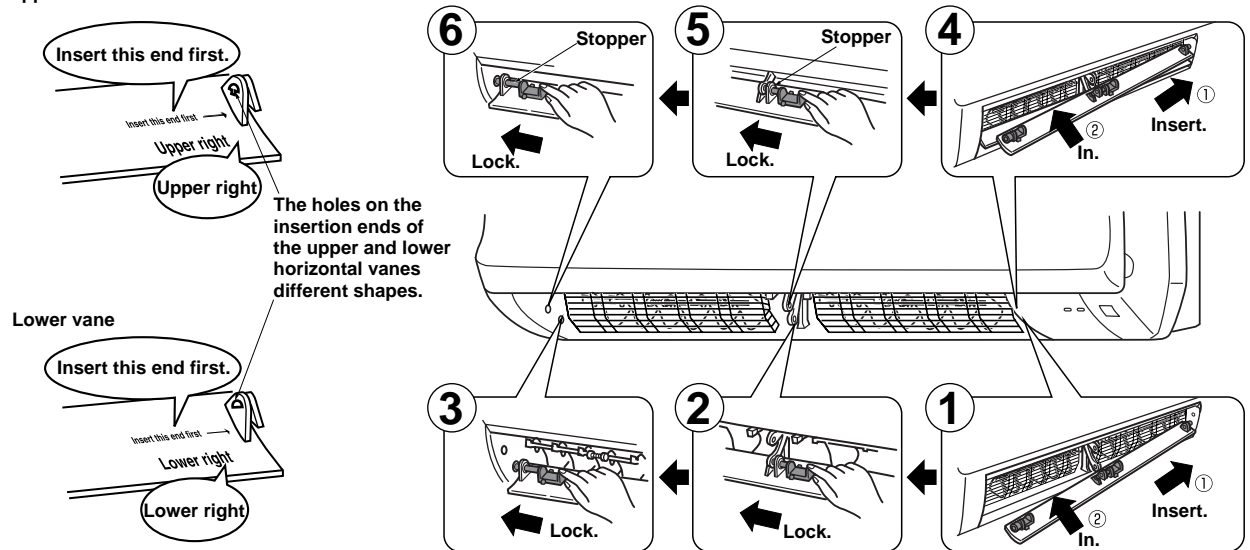

In procedures ②,③,⑤, and ⑥, lock the stoppers until they click into place.

INFORMATION FOR MULTI SYSTEM AIR CONDITIONER OUTDOOR UNIT : MXZ series

Multi system air conditioner can connect two or more indoor units with one outdoor unit.

- Unit won't operate in case the total capacity of indoor units exceeds the capacity of outdoor units. Do not connect indoor units beyond the outdoor unit capacity.
Operation indicator lamp flashes as shown in the figure below.
- When you try to operate two or more indoor units with one outdoor unit simultaneously, one for the cooling and the other for heating, the operation mode of the indoor unit that operates earlier is selected. The other indoor units will start the operation later cannot operate, indicating as shown in the figure below. In this case, please set all the indoor units to the same operation mode.

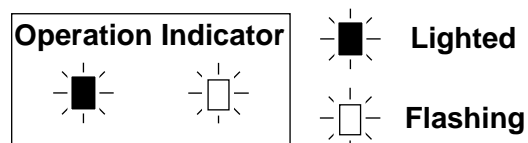

- When indoor units starts the operation while the defrosting of outdoor unit is being done, it takes a few minutes (max. 10 minutes) to blow out the warm air.
- In the heating operation, though indoor unit that does not operate may get warm or the sound of refrigerant flowing may be heard, they are not malfunction. The reason is that the refrigerant continuously flows into it.

8-2. Instruction of troubleshooting

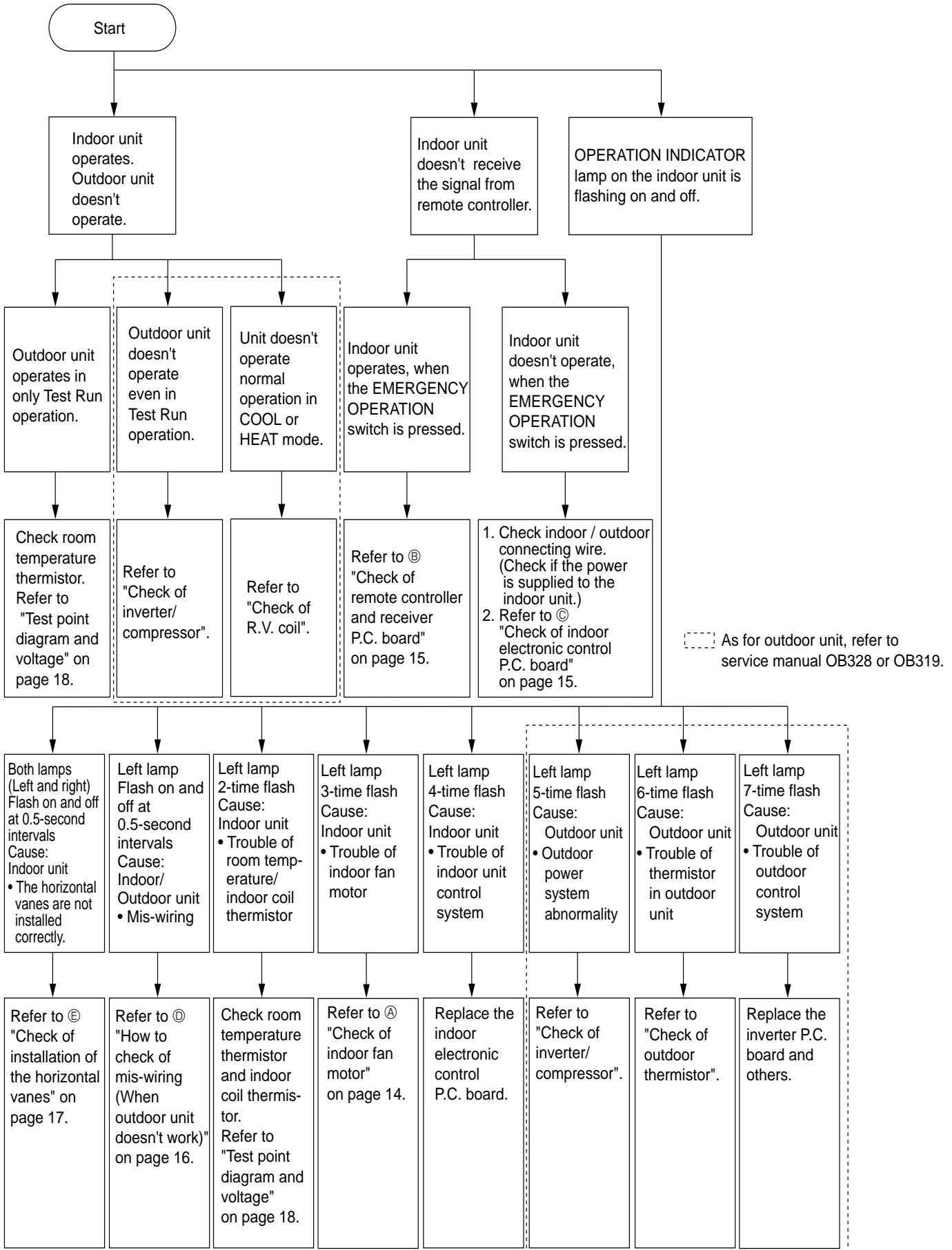

1. Troubleshooting check table

- The following indication applies regardless of shape of the indicator.

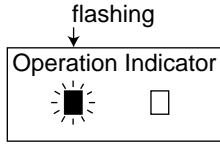

- Flashing of the OPERATION INDICATOR lamp (on the left or both) indicates possible abnormalities.
- The OPERATION INDICATOR lamp (on the left) is lighting during normal operation.

NOTE : Before taking measures, make sure that the symptom reappears for accurate troubleshooting.
Self check table

No.	Abnormal point	Operation indicator lamp	Symptom	Detection method	Check point
1	Attachment of the horizontal vane	Both lamps flash at the same time. 0.5-second ON 0.5-second OFF	Indoor unit and outdoor unit do not operate.	When the electricity is not conducted to the safety device (FAN) of the horizontal vane.	• Refer to ㊦ "Check of installation of the horizontal vanes" on page 17.
	Mis-Wiring	Left lamp flashes. 0.5-second ON 0.5-second OFF	Outdoor unit does not operate.	3 minutes after power supply turns ON, when serial signal is not received.	• Refer to ㊦ "How to check mis-wiring " on page 16.
※2	Indoor coil thermistor	Left lamp flashes. 2-time flash 2.5-second OFF	Outdoor unit does not operate.	Detect Indoor coil/room temperature thermistor short or open circuit every 8 seconds during operation.	• Refer to the characteristics of indoor coil thermistor, sub indoor coil thermistor, and room temperature thermistor on page 18.
	Room temperature thermistor	 2.5-second OFF			
※3	Indoor fan motor	Left lamp flashes. 3-time flash 2.5-second OFF	Indoor fan repeats 12 seconds ON and 3 minutes OFF. When the indoor fan breaks, the fan keeps stopping.	When rotational frequency feedback signal is not emit during 12-second indoor fan operation.	• Refer to ㊦ "Check of indoor fan motor" on page 14.
4	Indoor control system	Left lamp flashes. 4-time flash 2.5-second OFF	Outdoor unit does not operate.	When it cannot properly read data in the nonvolatile memory of indoor electronic control P.C. board.	• Replace the indoor electronic control P.C. board.
5	Outdoor power system	Left lamp flashes. 5-time flash 2.5-second OFF	Outdoor unit does not operate.	When compressor has stopped due to over current protection or start-up failure protection 3 times in a row within 5 seconds after start-up.	• Refer to "Check of inverter/compressor". Refer to service manual OB328 or OB319.
6	Outdoor thermistors	Left lamp flashes. 6-time flash 2.5-second OFF	Outdoor unit does not operate.	<Thermistor short> Thermistors are abnormal when they short after compressor start-up. <Thermistor open> Thermistors are abnormal when they open after compressor start-up. However, discharge temperature thermistor is abnormal when open circuit is detected more than 10 minutes after compressor start-up.	• Shortage of refrigerant • Replace the outdoor control P.C. board. Refer to "Check of outdoor thermistor". Refer to service manual OB328 or OB319.
7	Outdoor control system	Left lamp flashes. 7-time flash 2.5-second OFF	Outdoor unit does not operate.	When it cannot properly read data in the nonvolatile memory of outdoor electronic control P.C. board.	• Replace the outdoor electronic control P.C. board or inverter P.C. board. Refer to service manual OB328 or OB319.
8	MXZ type Operation mode setting	Both lamp Operation Indicator Lighted Flashing 2.5-second OFF	Outdoor unit operates but indoor unit does not operate.	When the operation mode of each indoor unit is differently set to COOL(includes DRY) and HEAT at same time, the operation mode of indoor unit that has operated at first has the priority.	• Unify the operation mode. Refer to service manual OB319.

NOTE : ※ When the indoor unit has started operation and the above detection method has detected an abnormality (the first detection after the power ON), the indoor electronic control P.C. board turns OFF the 52C and the indoor fan motor with the OPERATION INDICATOR lamp lighting.

When the 52C and the indoor fan motor are turned ON again 3 minutes later and the same abnormality is detected (a second detection of the above abnormality after the power ON), the indoor electronic control P.C. board turns OFF the 52C and the indoor fan motor with the OPERATION INDICATOR lamp flashing.

However, the first detection is cleared in case the power is turned OFF after the first detection.

2. Trouble criterion of main parts

MSZ-A09YV -[E1] MSZ-A12YV -[E1]

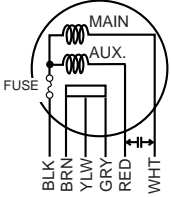
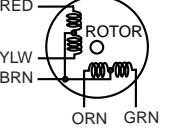
Part name	Check method and criterion	Figure												
Room temperature thermistor(RT11)	Measure the resistance with a tester. (Part temperature 10°C ~ 30°C)	/												
Indoor coil thermistor (RT12(MAIN), RT13(SUB))														
Indoor fan motor(MF)	Measure the resistance between the terminals with a tester. (Part temperature 10°C ~ 30°C) <table border="1" style="width: 100%; text-align: center;"> <thead> <tr> <th></th> <th>Normal</th> <th>Abnormal</th> </tr> </thead> <tbody> <tr> <td>Color of lead wire</td> <td></td> <td></td> </tr> <tr> <td>WHT – BLK</td> <td>303 Ω ~ 329 Ω</td> <td>Open or short-circuit</td> </tr> <tr> <td>BLK – RED</td> <td>287 Ω ~ 311 Ω</td> <td>Open or short-circuit</td> </tr> </tbody> </table>		Normal	Abnormal	Color of lead wire			WHT – BLK	303 Ω ~ 329 Ω	Open or short-circuit	BLK – RED	287 Ω ~ 311 Ω	Open or short-circuit	
		Normal	Abnormal											
Color of lead wire														
WHT – BLK	303 Ω ~ 329 Ω	Open or short-circuit												
BLK – RED	287 Ω ~ 311 Ω	Open or short-circuit												
INNER FUSE 136± 3°C CUT OFF	Measure the voltage power ON. <table border="1" style="width: 100%; text-align: center;"> <thead> <tr> <th>Color of lead wire</th> <th>Normal</th> <th>Abnormal</th> </tr> </thead> <tbody> <tr> <td>BRN – YLW</td> <td>4.5 ~ 5.5V</td> <td rowspan="2">Remain 0V or 5V</td> </tr> <tr> <td>YLW – GRY</td> <td>(When fan revolved one time) 0V→5V→0V (Approx.)</td> </tr> </tbody> </table>	Color of lead wire	Normal	Abnormal	BRN – YLW	4.5 ~ 5.5V	Remain 0V or 5V	YLW – GRY	(When fan revolved one time) 0V→5V→0V (Approx.)					
Color of lead wire	Normal	Abnormal												
BRN – YLW	4.5 ~ 5.5V	Remain 0V or 5V												
YLW – GRY	(When fan revolved one time) 0V→5V→0V (Approx.)													
Vane motor(MV)	Measure the resistance between the terminals with a tester. (Part temperature 10°C ~ 30°C) <table border="1" style="width: 100%; text-align: center;"> <thead> <tr> <th>Color of lead wire</th> <th>Normal</th> <th>Abnormal</th> </tr> </thead> <tbody> <tr> <td>BRN-other one</td> <td>240 Ω ~ 260 Ω</td> <td>Open or short-circuit</td> </tr> </tbody> </table>	Color of lead wire	Normal	Abnormal	BRN-other one	240 Ω ~ 260 Ω	Open or short-circuit							
Color of lead wire	Normal	Abnormal												
BRN-other one	240 Ω ~ 260 Ω	Open or short-circuit												

When OPERATION INDICATOR lamp flashes 3-time.
Indoor fan does not operate.

Ⓐ Check of indoor fan motor

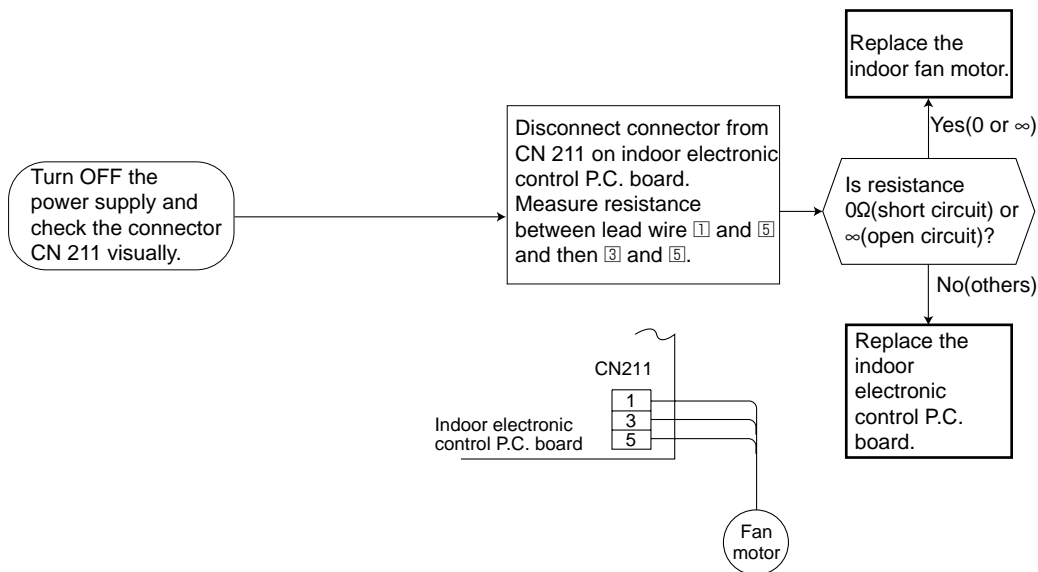

Indoor unit operates by pressing the EMERGENCY OPERATION switch, but does not operate with the remote controller.

Ⓑ Check of remote controller and receiver P.C. board

※Check if the remote controller is exclusive for this air conditioner.

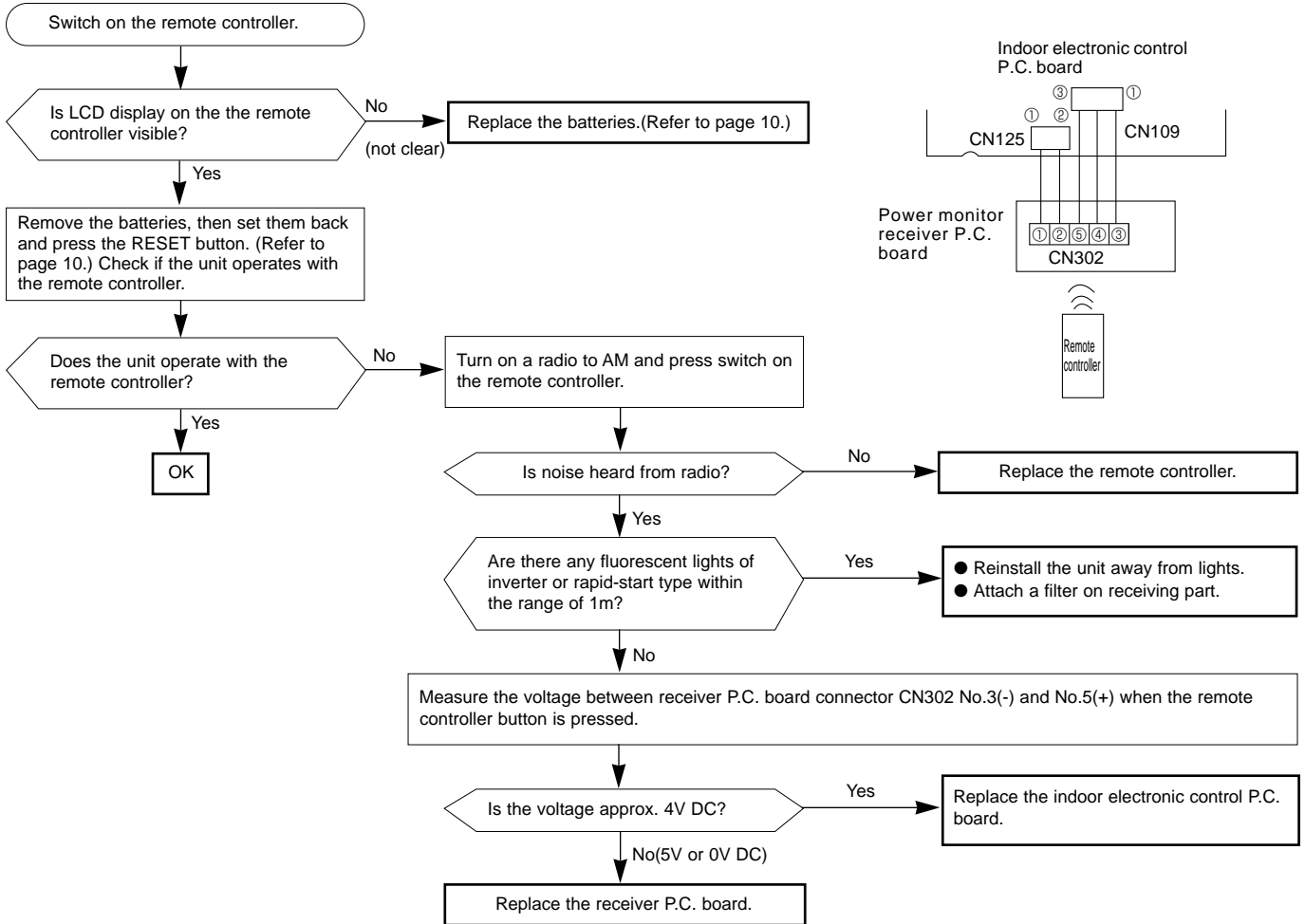

The unit doesn't operate with the remote controller. Also, the OPERATION INDICATOR lamp doesn't light up by pressing the EMERGENCY OPERATION switch.

Ⓒ Check of indoor electronic control P.C. board

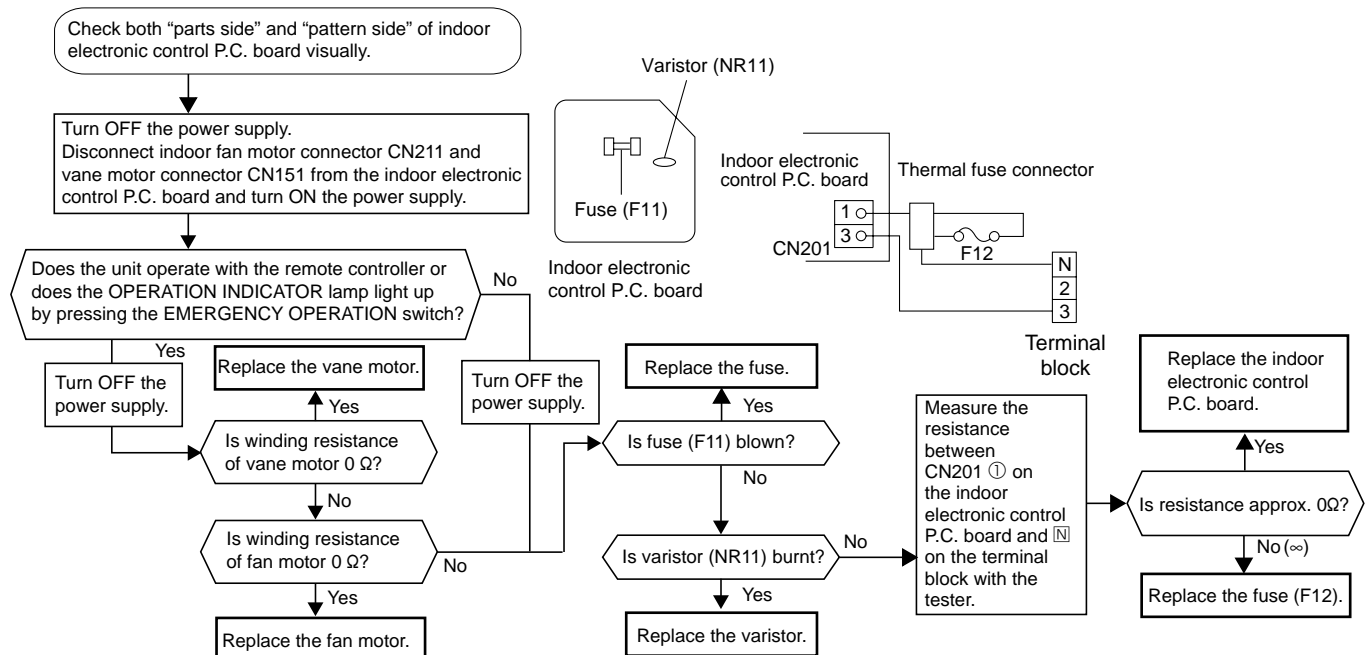

When OPERATION INDICATOR lamp flashes ON and OFF in every 0.5-second or flashes once.
Outdoor unit doesn't operate.

④ How to check mis-wiring

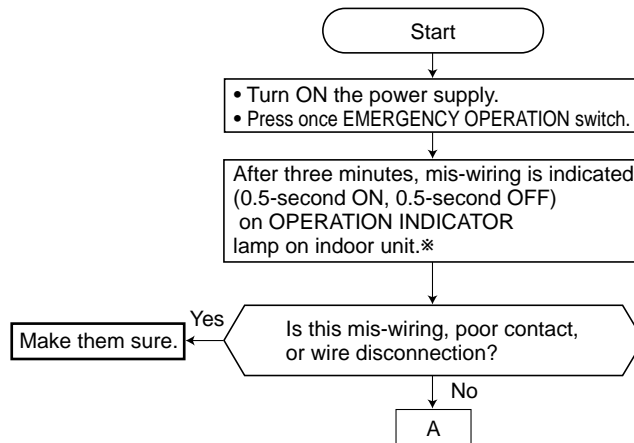

* Short circuit of JPG and JPS on the indoor electronic control P.C. board enables self-check to be displayed in 3 seconds.

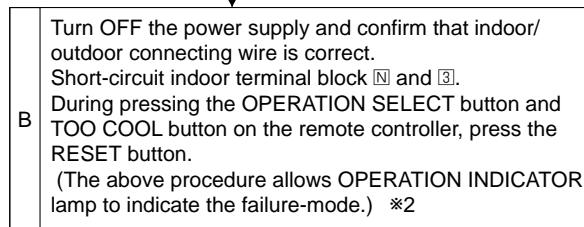

*2 Mis-wiring may damage indoor electronic control P.C. board during the operation in the left. Be sure to confirm the wiring is correct before the operation starts.

•The following indication applies regardless of shape of the indicator.

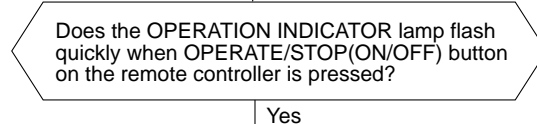
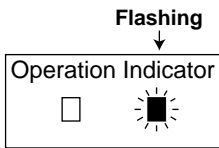

*3 Replace the indoor electronic control P.C. board.

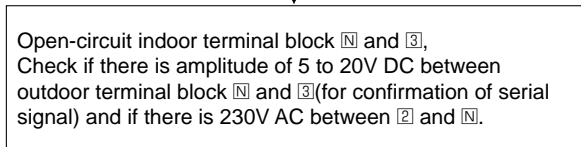

*3 Be sure to release the failure-mode recall function after checking.
Procedure of release of failure-mode
① Press the EMERGENCY OPERATION switch.
② Turn OFF the power supply and then turn ON again.
③ Press the RESET button on the remote controller.

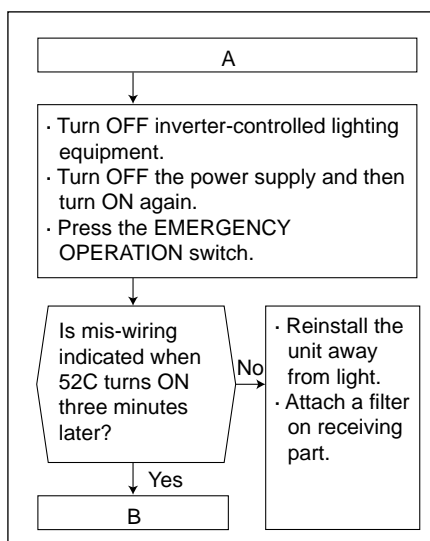
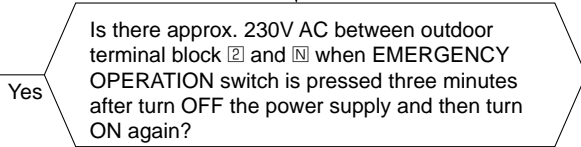
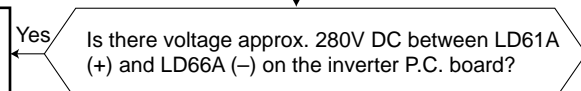
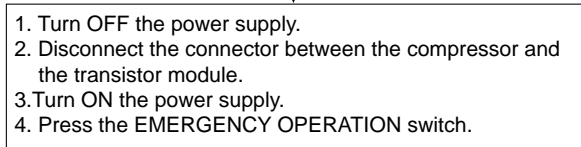

As for outdoor unit, refer to service manual OB328 or OB319.

When both OPERATION INDICATOR lamps flash 1-time.
Indoor unit and outdoor unit don't operate.

E Check of installation of the horizontal vanes

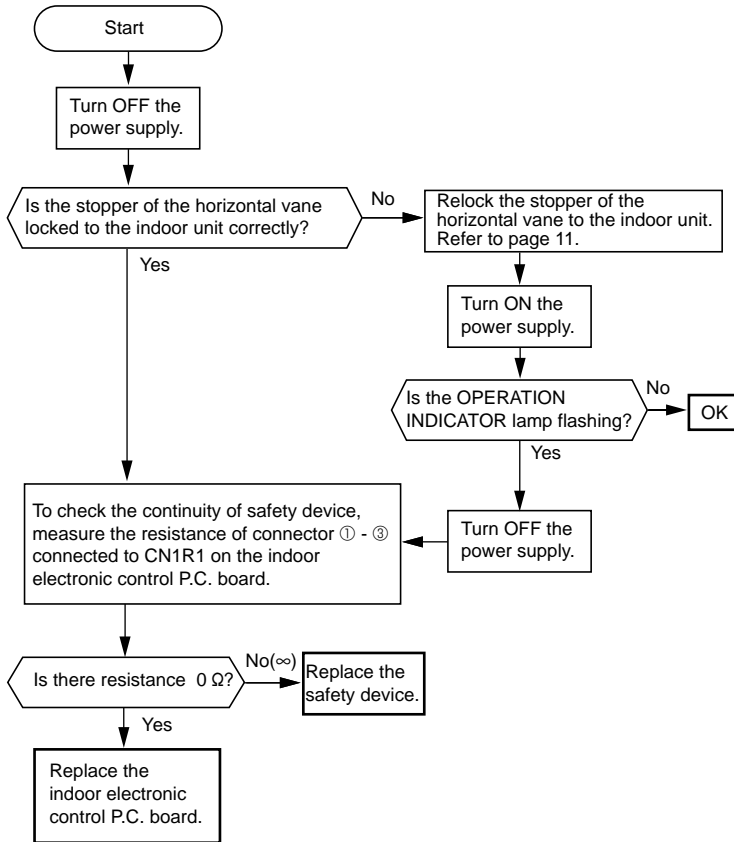

F Check of thermal fuse

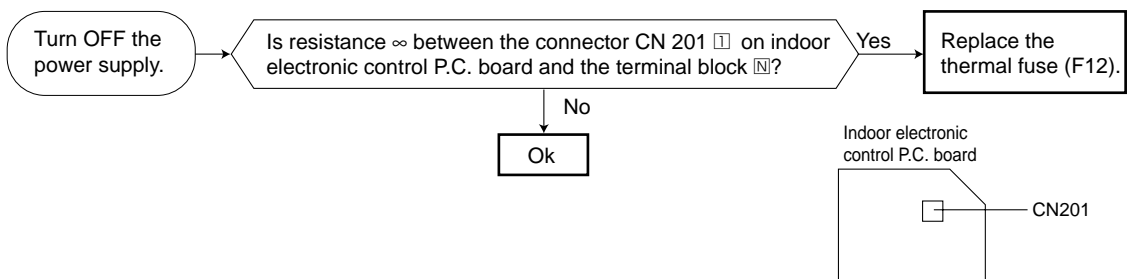

TEST POINT DIAGRAM AND VOLTAGE
MSZ-A09YV -E1 MSZ-A12YV -E1
Indoor electronic control P.C. board

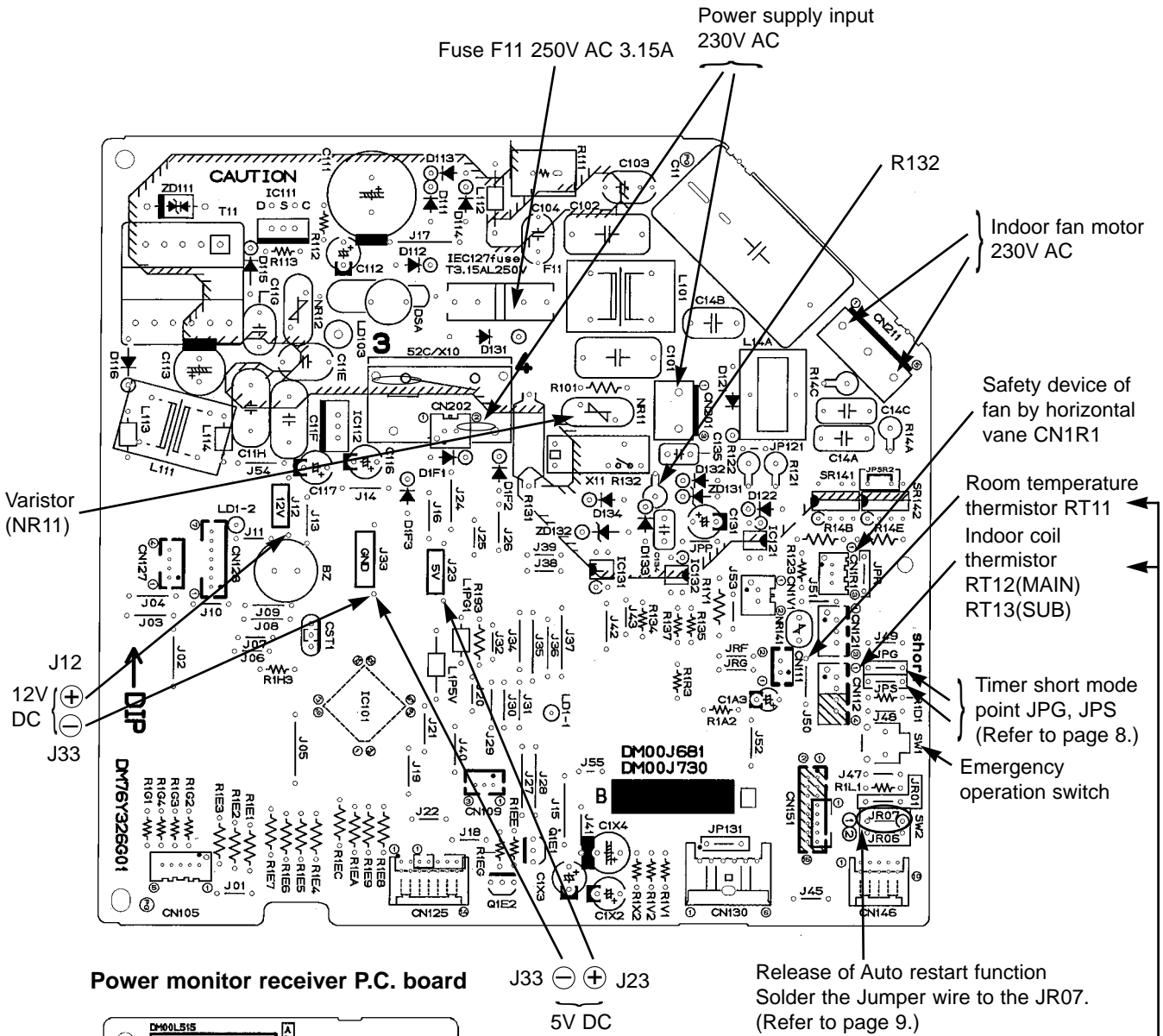

Power monitor receiver P.C. board

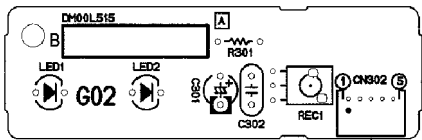

CN302

**Indoor coil thermistor [RT12 (MAIN), RT13 (SUB)]
 Room temperature thermistor (RT11)**

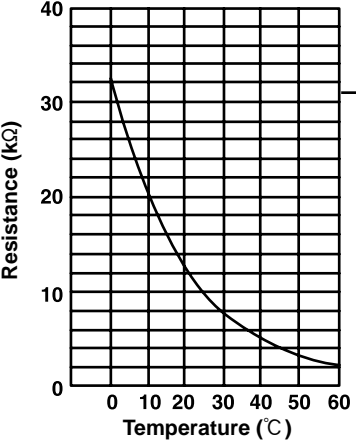

<"Terminal with lock mechanism" Detaching points>

In case of terminal with lock mechanism, detach the terminal as shown below.
There are two types (Refer to (1) and (2)) of the terminal with lock mechanism.
The terminal with no lock mechanism can be removed by pulling it out.
Check the shape of the terminal and work.

(1) Slide the sleeve and check if there is a locking lever or not.

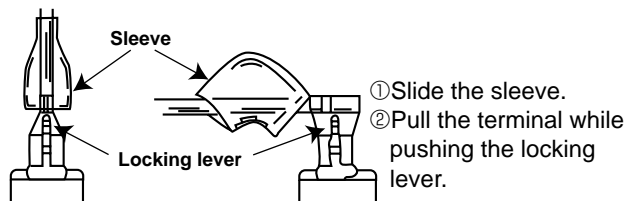

(2) The terminal with this connector is a terminal with lock mechanism

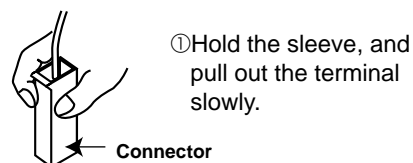

9-1. MSZ-A09YV -E1 MSZ-A12YV -E1 INDOOR UNIT

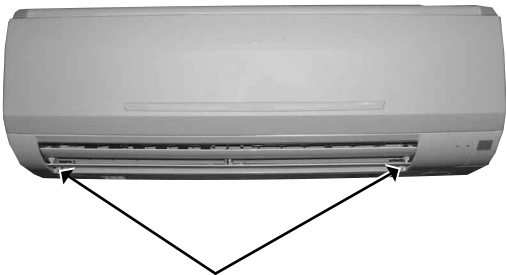
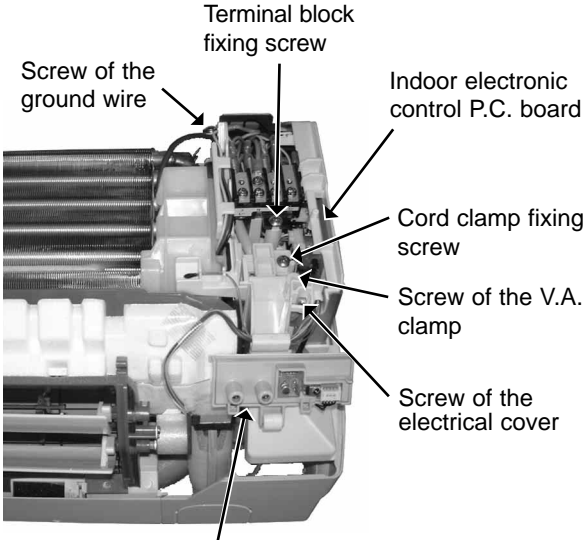
OPERATING PROCEDURE	PHOTOS
<p>1. Removing the panel</p> <ol style="list-style-type: none"> (1) Remove the screw caps of the panel. Remove the screws. (2) Pull the panel down to your side slightly and unhook the catches at the top. 	<p>Photo 1</p>  <p>Screws of the panel</p>
<p>2. Removing the electronic control P.C. board and the power monitor receiver P.C. board</p> <p>NOTE : In case of removing only indoor electronic control P.C. board work (3) is not necessary.</p> <ol style="list-style-type: none"> (1) Remove the panel. (Refer to 1.) (2) Remove the power monitor receiver P.C. board holder from the bottom of electrical box. (3) Open the power monitor receiver P.C. board holder and remove the power monitor receiver P.C. board. (4) Remove the screw of the electrical cover and the electrical cover. (5) Remove the screw of the V.A. clamp and the V.A. clamp. (6) Remove the screw of the cord clamp and the cord clamp. (7) Remove the screw of the terminal block. (8) Remove the screw of the ground wire. (9) Pull out indoor electronic control P.C. board slightly. (10) Disconnect all (except CN109, CN125) the connectors on the electronic control P.C. board. (11) Remove the electronic control P.C. board. (12) Disconnect the connector of power monitor receiver P.C. board (CN109, CN125) on the electronic control P.C. board. 	<p>Photo 2</p>  <p>Terminal block fixing screw Indoor electronic control P.C. board Cord clamp fixing screw Screw of the V.A. clamp Screw of the electrical cover Power monitor receiver P.C. board holder Screw of the ground wire</p>

OPERATING PROCEDURE

3. Removing the electrical box

- (1) Remove the panel. (Refer to 1.)
- (2) Remove the electrical cover. (Refer to 2.)
- (3) Remove the V.A. clamp. (Refer to 2.)
- (4) Remove the cord clamp. (Refer to 2.)
- (5) Remove the terminal block. (Refer to 2.)
- (6) Remove the screw of ground wire. (Refer to 2.)
- (7) Disconnect the connector of the indoor coil thermistor (CN112), the fan motor connector (CN211 and CN121), the vane motor connector (CN151) and the connector of the safety device (CN1R1) on the electronic control P.C. board.
- (8) Remove the fan motor lead wire and indoor coil thermistor from the bottom of electrical box.
- (9) Remove the lead wire of vane motor and safety device from the bottom of electrical box.
- (10) Remove the screw fixing the electrical box, remove the electrical box.

Photo 3

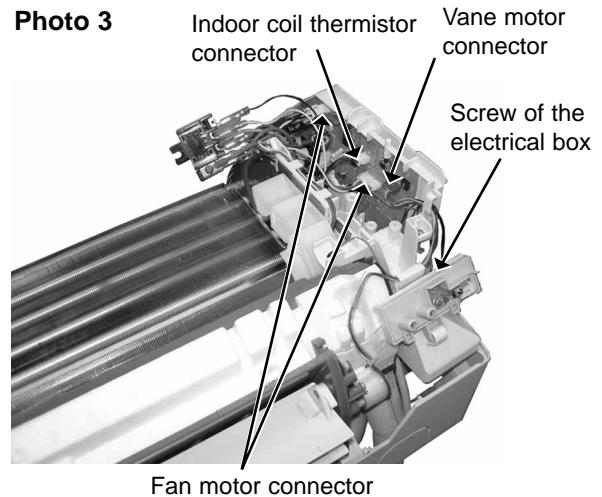

4. Removing the nozzle assembly and the vane motor

- (1) Remove the panel. (Refer to 1.)
- (2) Remove the electrical box. (Refer to 3.)
- (3) Pull out the drain hose from the nozzle assembly, remove the nozzle assembly.
- (4) Remove the screws of the vane motor, disconnect the vane motor connector.
- (5) Remove the vane motor.

Photo 4

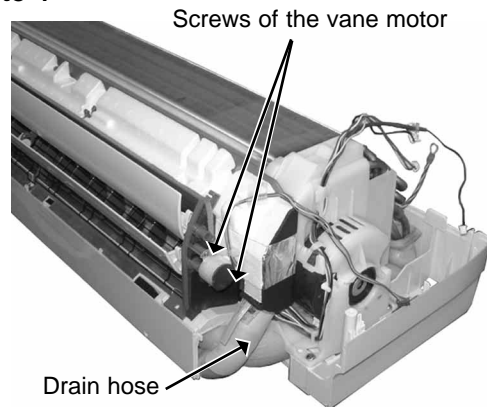

5. Removing the indoor fan motor and the line flow fan

- (1) Remove the panel. (Refer to 1.)
- (2) Remove the electrical box. (Refer to 3.)
- (3) Pull out the drain hose from the nozzle assembly, remove the nozzle assembly. (Refer to 4.)
- (4) Remove the screw of the lead cover and the lead cover.
- (5) Remove the lead wire of the fan motor.
- (6) Release the hooks of the motor band and open it slightly.
- (7) Loosen the hexagon socket set screw of the line flow fan.
- (8) Remove the screws fixing the motor bed, remove the fan motor with motor band and the motor bed.
- (9) Remove the screws fixing the left side of the heat exchanger.
- (10) Lift the left side of the heat exchanger.
- (11) Remove the line flow fan.

Photo 5

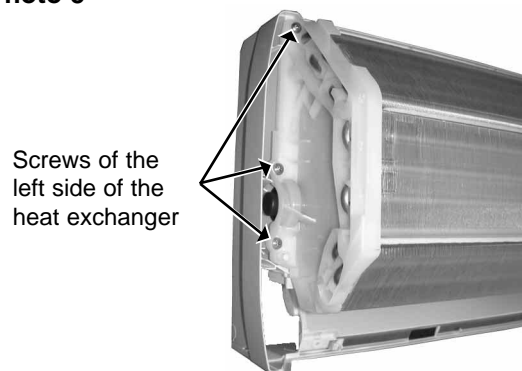

Photo 6

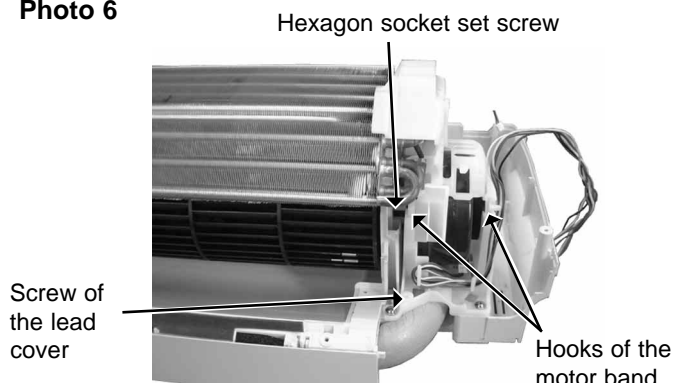
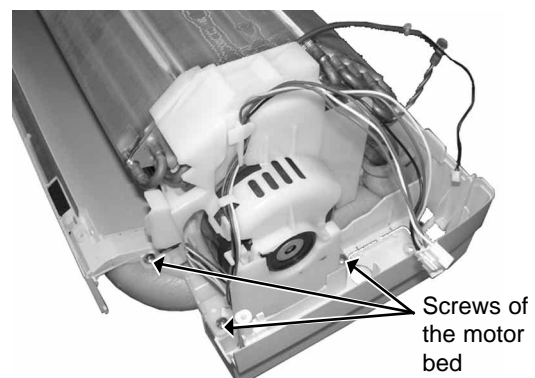

Photo 7



10

PARTS LIST

MSZ-A09YV -^[E1] (WH)

MSZ-A12YV -^[E1] (WH)

10-1. INDOOR UNIT STRUCTURAL PARTS

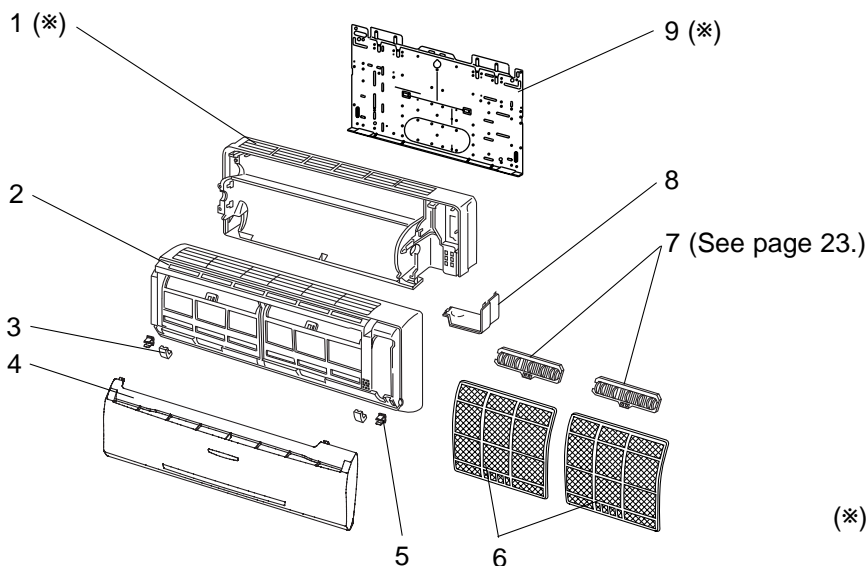

10-2. ACCESSORY AND REMOTE CONTROLLER

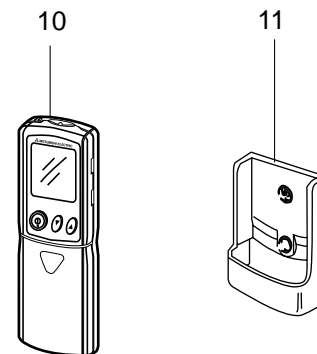

(*) These figures show about MSZ-A12YV.

10-1. INDOOR UNIT STRUCTURAL PARTS

No.	Part No.	Part name	Symbol in Wiring Diagram	Q'ty/unit		Remarks
				MSZ-A09YV - ^[E1] (WH)	MSZ-A12YV - ^[E1] (WH)	
1	E02 749 234	BOX (WH)		1		
	E02 751 234	BOX (WH)			1	
2	E02 838 000	PANEL ASSEMBLY (WH)		1	1	Including No.3,4,5
3	E02 749 067	SCREW CAP		2	2	2PCS/SET
4	E02 838 010	FRONT PANEL (WH)		1	1	
5	E02 408 142	CATCH		2	2	2PCS/SET
6	E02 763 100	CATECHIN AIR FILTER		2		
	E02 764 100	CATECHIN AIR FILTER			2	
7	—————	AIR CLEANING FILTER		2	2	MAC-1300FT
8	E02 749 975	CORNER BOX (RIGHT)		1	1	
9	E02 408 970	INSTALLATION PLATE		1		
	E02 751 970	INSTALLATION PLATE			1	

10-2. ACCESSORY AND REMOTE CONTROLLER

10	E02 838 426	REMOTE CONTROLLER		1	1	KG04A
11	E02 527 083	REMOTE CONTROLLER HOLDER		1	1	

MSZ-A09YV -^[E1] (WH)
MSZ-A12YV -^[E1] (WH)

10-3. INDOOR UNIT ELECTRICAL PARTS AND FUNCTIONAL PARTS

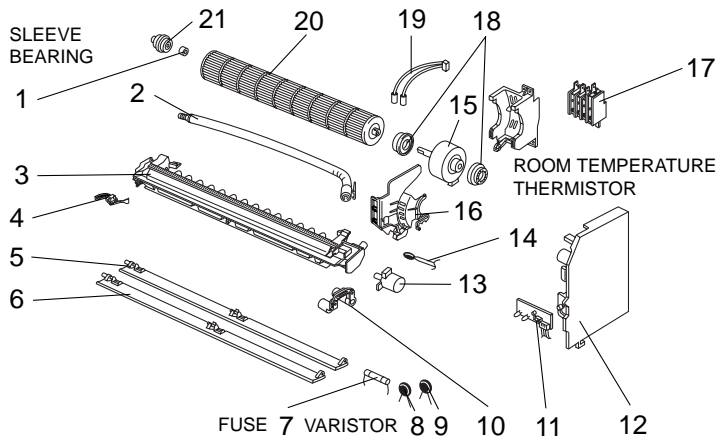

10-4. INDOOR UNIT HEAT EXCHANGER

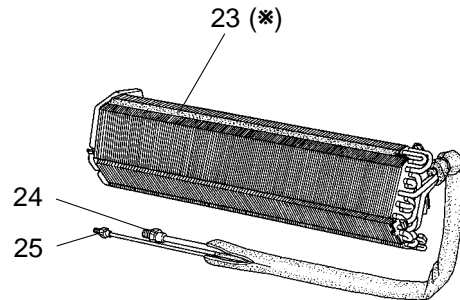

(* This figure shows about MSZ-A12YV.

10-3. INDOOR UNIT ELECTRICAL PARTS AND FUNCTIONAL PARTS

Part number that is circled is not shown in the illustration.

No.	Part No.	Part name	Symbol in Wiring Diagram	Q'ty/unit		Remarks
				MSZ-A09YV- ^[E1] (WH)	MSZ-A12YV- ^[E1] (WH)	
1	E02 001 504	SLEEVE BEARING		1	1	
2	E02 661 702	DRAIN HOSE		1	1	
3	E02 838 235	NOZZLE ASSEMBLY (WH)		1	1	
4	E02 815 316	SAFETY DEVICE		1	1	
5	E02 838 040	VANE UPPER		1	1	
6	E02 838 041	VANE LOWER		1	1	
7	E02 127 382	FUSE	F11	1	1	3.15A
8	E02 829 385	VARISTOR	NR11	1	1	
9	E02 749 385	VARISTOR	NR12	1	1	
10	E02 763 034	VANE CRANK SET		1	1	
11	E02 815 468	POWER MONITOR RECEIVER P.C. BOARD		1	1	
12	E02 838 452	ELECTRONIC CONTROL P.C. BOARD		1		AUTO RESTART
	E02 839 452	ELECTRONIC CONTROL P.C. BOARD			1	AUTO RESTART
13	E02 749 303	VANE MOTOR	MV	1	1	
14	E02 151 308	ROOM TEMPERATURE THERMISTOR	RT11	1	1	
15	E02 749 300	INDOOR FAN MOTOR	MF	1		RC4V19-□□
	E02 751 300	INDOOR FAN MOTOR	MF		1	RC4V19-□□
16	E02 749 333	MOTOR BAND		1	1	
17	E02 679 375	TERMINAL BLOCK	TB	1	1	
18	E02 665 505	FAN MOTOR RUBBER MOUNT		2		2PCS/SET
	E02 151 505	FAN MOTOR RUBBER MOUNT			2	2PCS/SET
19	E02 838 307	INDOOR COIL THERMISTOR	RT12, RT13	1	1	
20	E02 749 302	LINE FLOW FAN		1	1	
21	E02 408 509	BEARING MOUNT		1		
	E02 751 509	BEARING MOUNT			1	
②	E02 408 381	THERMAL FUSE	F12	1	1	93℃

10-4. INDOOR UNIT HEAT EXCHANGER

23	E02 749 620	INDOOR HEAT EXCHANGER		1		
	E02 839 620	INDOOR HEAT EXCHANGER			1	
24	E02 815 666	UNION (GAS)			1	φ9.52
	E02 151 666	UNION (GAS)		1		φ9.52
25	E02 151 667	UNION (LIQUID)		1	1	φ6.35

10-5. AIR CLEANING FILTER

- AIR CLEANING FILTER removes fine dust of 0.01 micron from air by means of static electricity.
- Normal life of AIR CLEANING FILTER is 4 months. However, when it becomes dirty, replace it as soon as possible.
- Clogged AIR CLEANING FILTER may reduce the air conditioner capacity or cause frost on the air outlet.
- DO NOT reuse AIR CLEANING FILTER even if it is washed.
- DO NOT remove or attach AIR CLEANING FILTER during unit operation.

Model	Part No.
MSZ-A09YV - E1 MSZ-A12YV - E1	MAC-1300FT

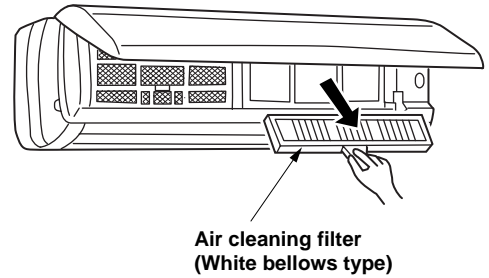

11

OPTIONAL PARTS

QUICK CLEAN KIT

- You can sweep the surface of heat exchanger if you install the special-made brush to your vacuum cleaner.

Model	Part No.	
MSZ-A09YV - E1 MSZ-A12YV - E1	MAC-093SS-E	

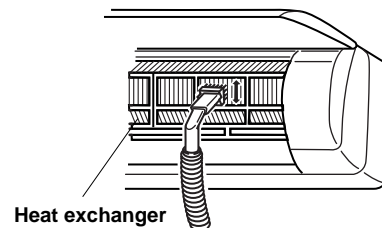



HEAD OFFICE: MITSUBISHI DENKI BLDG., 2-2-3, MARUNOUCHI, CHIYODA-KU, TOKYO100-8310, JAPAN

© Copyright 2004 MITSUBISHI ELECTRIC ENGINEERING CO.,LTD
Distributed in Jan. 2004. No. OB327 6
Made in Japan

New publication, effective Jan. 2004
Specifications subject to change without notice.