

Revision A:

- RoHS PARTS LIST has been added.

Please void OB385.

INDOOR UNIT

SERVICE MANUAL

No. OB385
REVISED EDITION-A

Wireless type Models

MSC-GA20VB - E1

MSC-GA25VB - E1

MSC-GA35VB - E1

Outdoor unit service manual
MU-GA•VB Series (OB386)
MUH-GA•VB Series (OB387)
MUX-A•VB Series (OB384)
MXZ-A•WV Series (OB319)

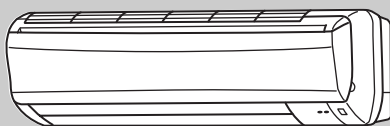

CONTENTS

1. TECHNICAL CHANGES	3
2. PART NAMES AND FUNCTIONS.....	3
3. SPECIFICATION.....	5
4. NOISE CRITERIA CURVES	5
5. OUTLINES AND DIMENSIONS	6
6. WIRING DIAGRAM	7
7. REFRIGERANT SYSTEM DIAGRAM	8
8. SERVICE FUNCTIONS	8
9. TROUBLESHOOTING.....	11
10. DISASSEMBLY INSTRUCTIONS.....	18
11. PARTS LIST.....	20
12. RoHS PARTS LIST.....	22
13. OPTIONAL PARTS	BACK PAGE

NOTE:

This service manual describes technical data of the indoor units.
RoHS compliant products have <G> mark on the spec name plate.
For servicing of RoHS compliant products, refer to the RoHS PARTS LIST (RoHS compliant).



Revision A :

- RoHS PARTS LIST has been added.

1

TECHNICAL CHANGES

MSC-A07YV -[E1] → MSC-GA20VB -[E1]

1. Indication of capacity has been changed. (BTU base → kW)
2. P.C. board has been changed.
3. Air cleaning filter has been changed to optional parts.
4. Fan motor has been changed.
5. Fan motor capacitor has been changed.
6. Color of indoor unit has been changed.

MSC-A09YV -[E1] → MSC-GA25VB -[E1]

1. Indication of capacity has been changed. (BTU base → kW)
2. P.C. board has been changed.
3. Air cleaning filter has been changed to optional parts.
4. Fan motor has been changed.
5. Fan motor capacitor has been changed.
6. Color of indoor unit has been changed.

MSC-A12YV -[E1] → MSC-GA35VB -[E1]

1. Indication of capacity has been changed. (BTU base → kW)
2. P.C. board has been changed.
3. Air cleaning filter has been changed to optional parts.
4. Fan motor has been changed.
5. Fan motor capacitor has been changed.
6. Color of indoor unit has been changed.

2

PART NAMES AND FUNCTIONS

MSC-GA20VB MSC-GA25VB MSC-GA35VB

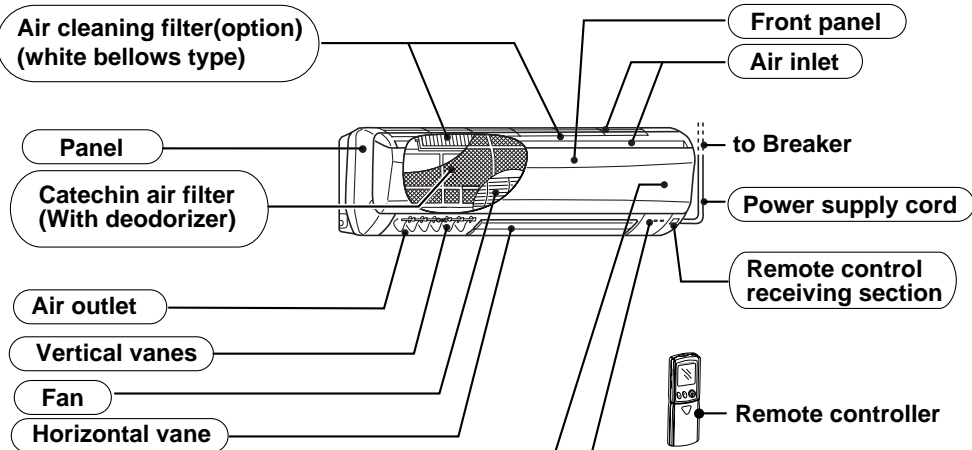

Operation section
(When the front panel is opened)

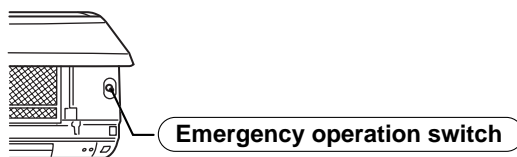

Display section

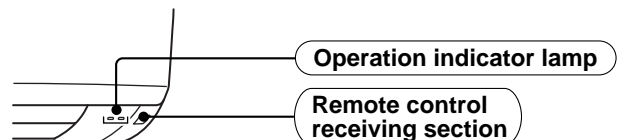

MSC-GA20VB
MSC-GA25VB
MSC-GA35VB

ACCESSORIES

①	Installation plate	1
②	Installation plate fixing screw 4 × 25 mm	5
③	Remote controller holder	1
④	Fixing screw for ③ 3.5 × 16 mm	2
⑤	Battery (AAA) for remote controller	2
⑥	Wireless remote controller	1
⑦	Felt tape (Used for left or left-rear piping)	1

REMOTE CONTROLLER

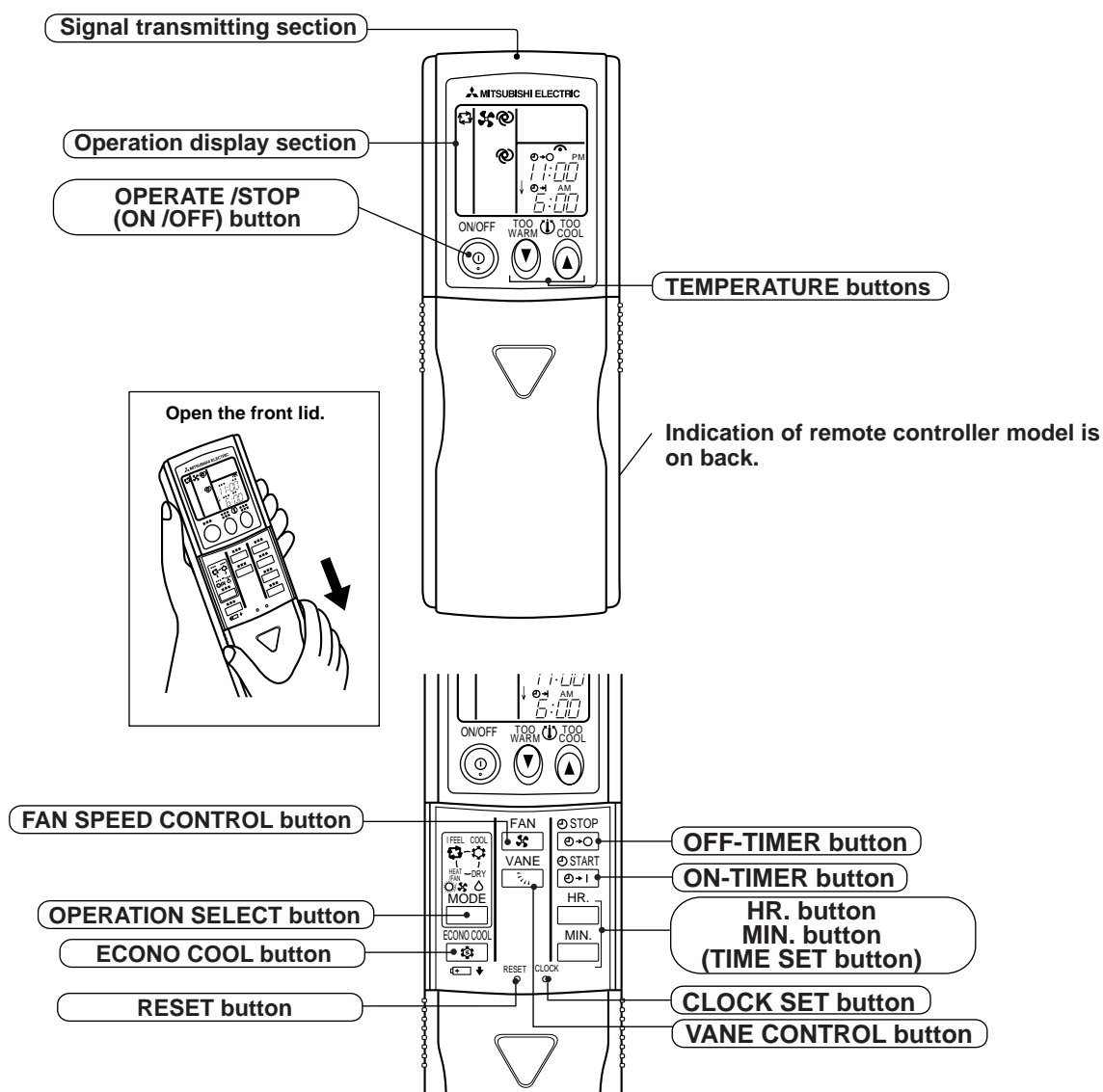

3

SPECIFICATION

Indoor model			MSC-GA20VB		MSC-GA25VB		MSC-GA35VB	
Function			Cooling	Heating	Cooling	Heating	Cooling	Heating
Indoor unit power supply			Single phase 230V,50Hz		Single phase 230V,50Hz		Single phase 230V,50Hz	
Capacity	Air flow(High/Med./Low*)	m ³ /h	474/372*/276*	510/420*/342*	474/384*/306*	588/456*/342*	582/444*/324*	606/498*/396*
Electrical data	Power outlet	A	10		10		10	
	Running current	A	0.17		0.17		0.19	
	Power input	W	35		35		40	
	Power factor	%	90		90		92	
	Fan motor current	A	0.17		0.17		0.19	
Fan motor	Model		RC4V19-JA		RC4V19-JA		RC4V19-HA	
	Winding resistance(at 20°C)	Ω	WHT-BLK 283 BLK-RED 188		WHT-BLK 283 BLK-RED 188		WHT-BLK 224 BLK-RED 318	
	Dimensions W×H×D	mm	815×278×244		815×278×244		815×278×244	
	Weight	kg	9		9		10	
Air direction			5		5		5	
Special remarks	Sound level(High/Med./Low*)	dB	36/31*/25*	36/31*/25*	36/31*/25*	39/32*/25*	40/33*/26*	39/33*/26*
	Fan speed(High/Med./Low*)	rpm	900/750*/600*	950/820*/700*	900/770*/650*	1,050/870*/700*	930/760*/600*	960/830*/700*
	Fan speed regulator		3		3		3	
	Thermistor RT11(at 25°C)	kΩ	10		10		10	
	Thermistor RT12(at 25°C)	kΩ	10		10		10	
Remote controller model			KP1A or KM04F		KP1A or KM04F		KP1A or KM04F	

NOTE: 1. Test conditions are based on ISO 5151.

Cooling : Indoor DB27°C WB19°C
 Outdoor DB35°C WB24°C

Heating : Indoor DB20°C
 Outdoor DB7°C WB6°C

Indoor-Outdoor piping length 5m

* Reference value

4

NOISE CRITERIA CURVES

MSC-GA20VB

FAN SPEED	FUNCTION	SPL(dB(A))	LINE
High	COOLING	36	●—●
	HEATING		

Test conditions,
 Cooling : DB27°C WB19°C
 Heating : DB20°C WB -°C

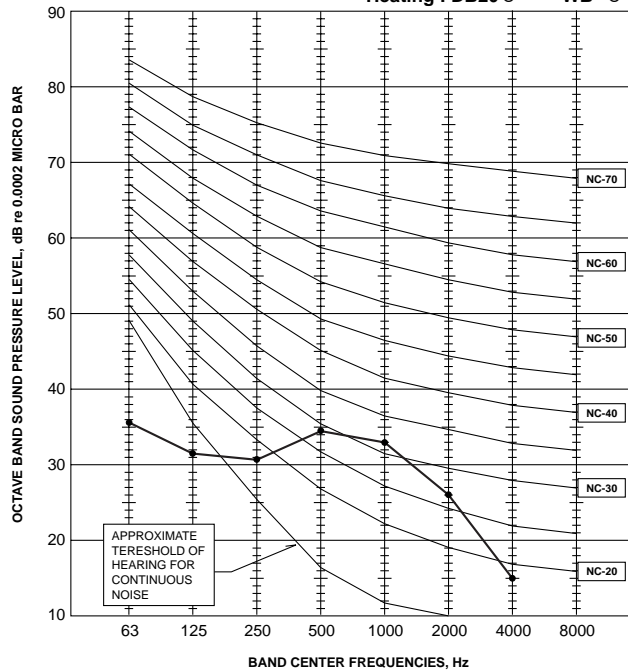

MSC-GA25VB

FAN SPEED	FUNCTION	SPL(dB(A))	LINE
High	COOLING	36	●—●
	HEATING		

Test conditions,
 Cooling : DB27°C WB19°C
 Heating : DB20°C WB -°C

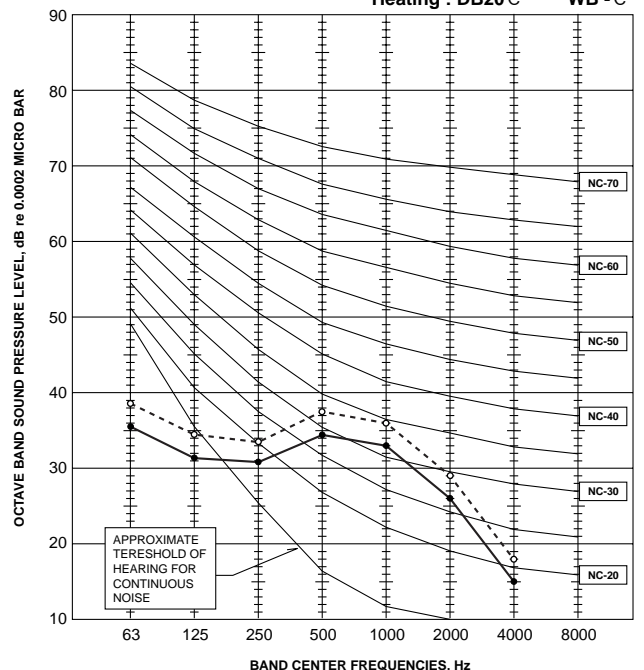

MSC-GA35VB

FAN SPEED	FUNCTION	SPL(dB(A))	LINE
High	COOLING	40	● — ●
	HEATING	39	○ - - - ○

Test conditions.

Cooling : DB27°C WB19°C
 Heating : DB20°C WB 19°C

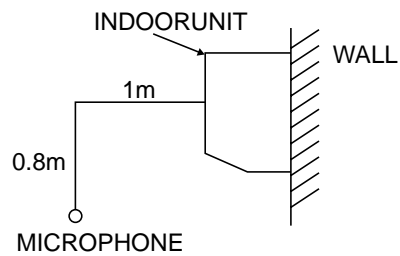
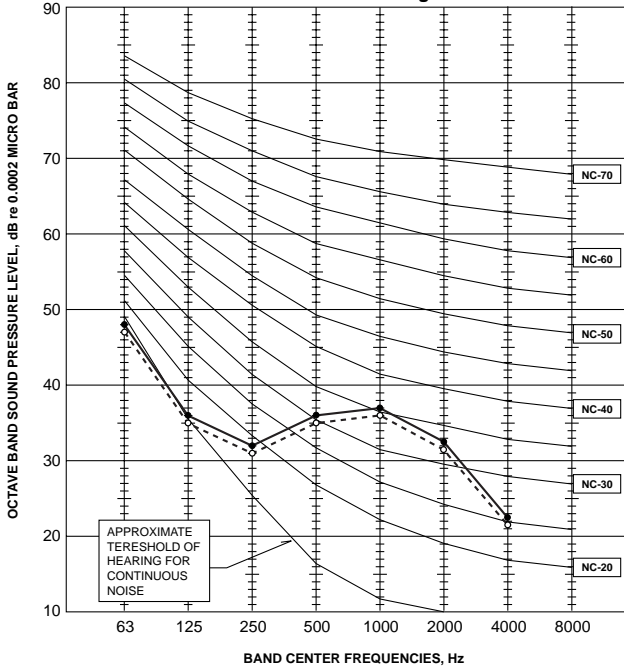

5

OUTLINES AND DIMENSIONS

MSC-GA20VB MSC-GA25VB

Unit: mm

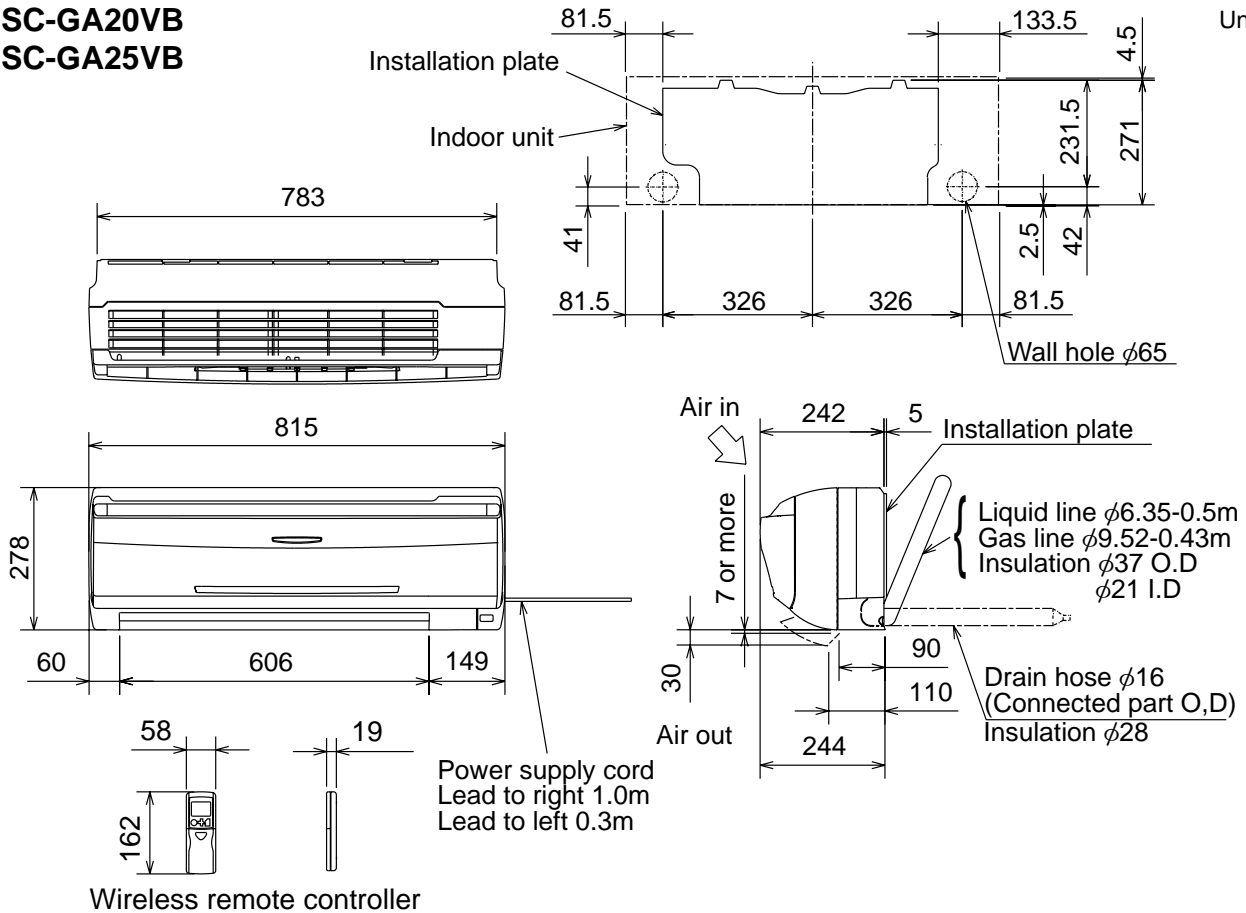

MSC-GA35VB

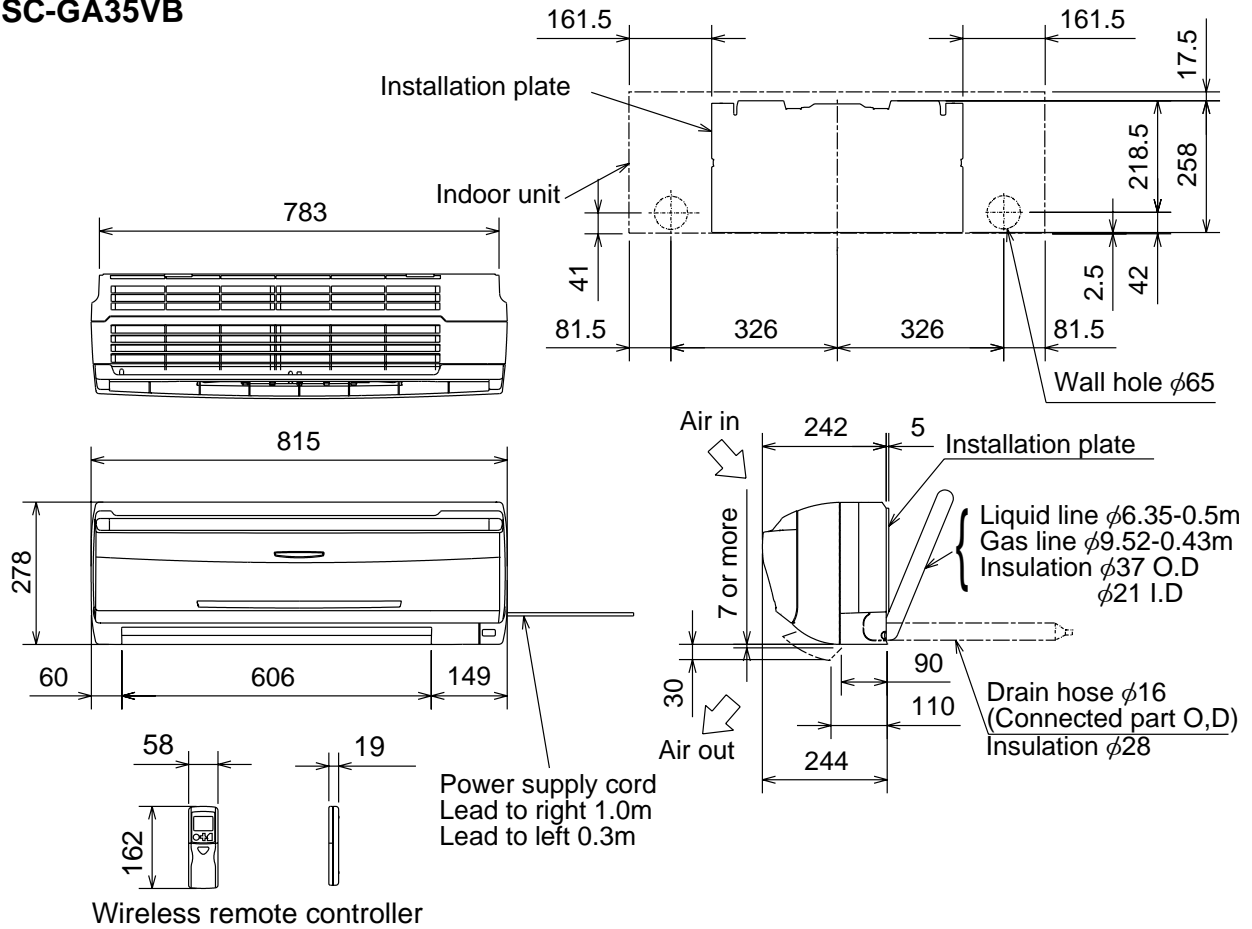

6

WIRING DIAGRAM

MSC-GA20VB MSC-GA25VB MSC-GA35VB

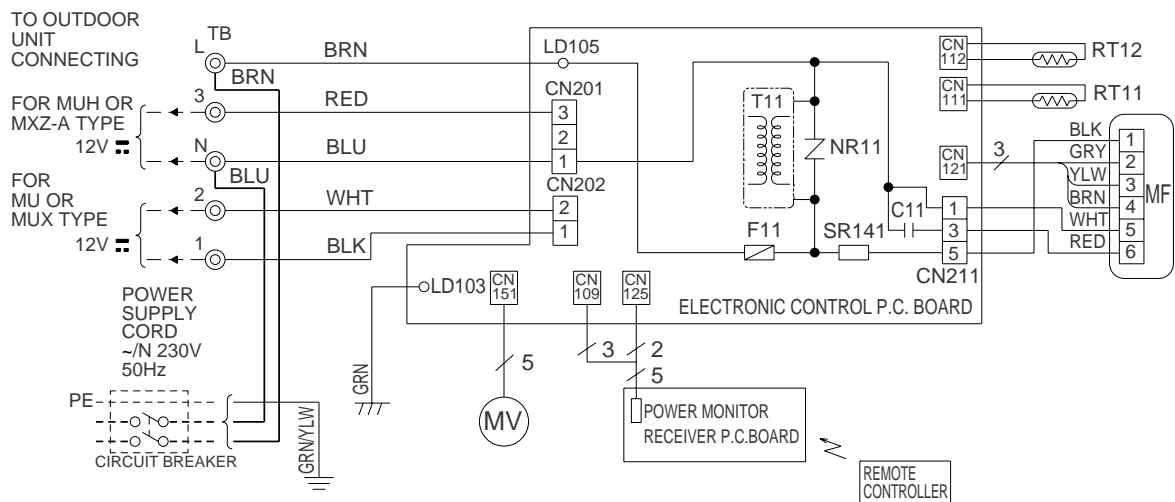

SYMBOL	NAME	SYMBOL	NAME	SYMBOL	NAME
C11	INDOOR FAN CAPACITOR	NR11	VARIATOR	TB	TERMINAL BLOCK
F11	FUSE(3.15A)	RT11	ROOM TEMPERATURE THERMISTOR	T11	TRANSFORMER
MF	INDOOR FAN MOTOR (INNER FUSE)	RT12	INDOOR COIL THERMISTOR		
MV	VANE MOTOR	SR141	SOLID STATE RELAY		

NOTE:1. About the outdoor side electric wiring refer to the outdoor unit electric wiring diagram for servicing.
 2. Use copper conductors only. (For field wiring)
 3. Symbols below indicate.
 ○: Terminal block, □□□□: Connector

MSC-GA20VB MSC-GA25VB MSC-GA35VB

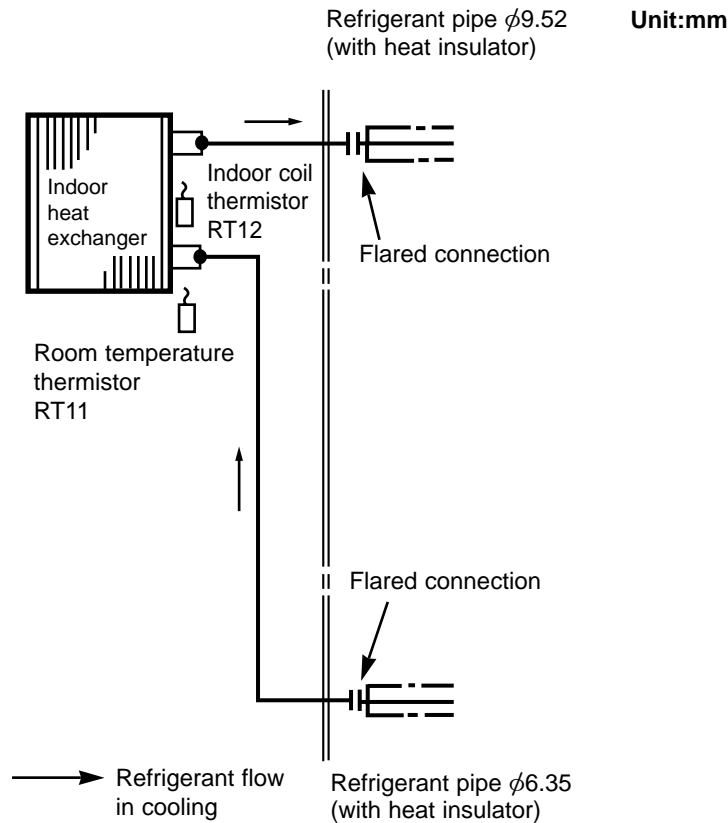

MSC-GA20VB MSC-GA25VB MSC-GA35VB

8-1. TIMER SHORT MODE

For service, set time can be shortened by short circuit of JPG and JPS the electronic control P.C. board.
The time will be shortened as follows. (Refer to 9-6.)

Set time : 1 minute \rightarrow 1-second

Set time : 3 minutes \rightarrow 3-second (It takes 3 minutes for the compressor to start operation. However, the starting time is shortened by short circuit of JPG and JPS.)

8-2. P.C. BOARD MODIFICATION FOR INDIVIDUAL OPERATION

A maximum of 4 indoor units with wireless remote controllers can be used in a room.

In this case, to operate each indoor unit individually by each remote controller, P.C. boards of remote controller must be modified according to the number of the indoor unit.

How to modify the remote controller P.C. board

Remove batteries before modification. The board has a print as shown below :

NOTE : For remodelling, take out the batteries and press the OPERATE/STOP(ON/OFF) button twice or 3 times at first. After finish remodelling, put back the batteries then press the RESET button.

Remote controller model : KP1A

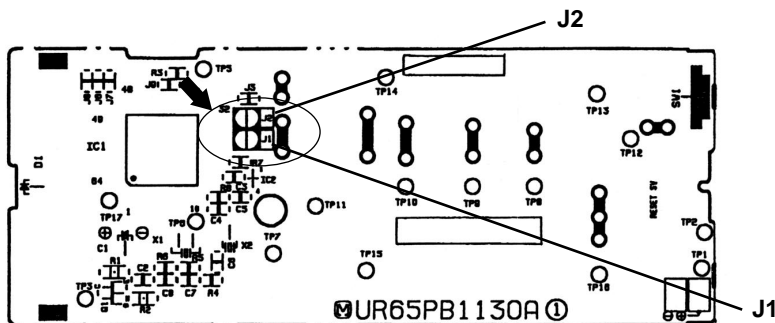



Remote controller model : KM04F

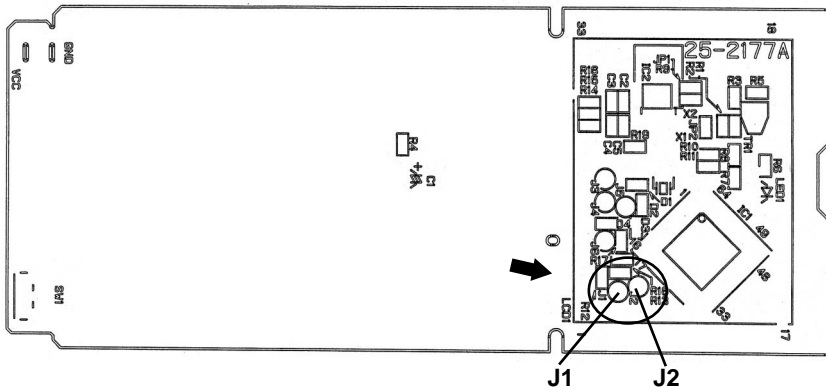

The P.C. board has the print “J1” and “J2”. Solder “J1” and “J2” according to the number of indoor unit as shown in Table 1. After modification, press the RESET button.

Table 1

	1 unit operation	2 units operation	3 units operation	4 units operation
No. 1 unit	No modification	Same as at left	Same as at left	Same as at left
No. 2 unit	—	Solder J1	Same as at left	Same as at left
No. 3 unit	—	—	Solder J2	Same as at left
No. 4 unit	—	—	—	Solder both J1 and J2

How to set the remote controller exclusively for particular indoor unit

After you turn the breaker ON, the first remote controller that sends the signal to the indoor unit will be regarded as the remote controller for the indoor unit.

The indoor unit only accepts the signal from the remote controller that has been assigned to the indoor unit once they are set.

The setting will be cancelled if the breaker has turned OFF, or the power supply has shut down.

Please conduct the above setting once again after the power has restored.

8-3. REMOTE CONTROLLER (How to set the type)

This remote controller setting needs to be switched according to the type of air conditioner (COOL & HEAT or COOL ONLY).

If the setting is incorrect, the air conditioner does not operate normally. Therefore, check if the setting corresponds to the type of air conditioner. If not, correct the setting as shown below.

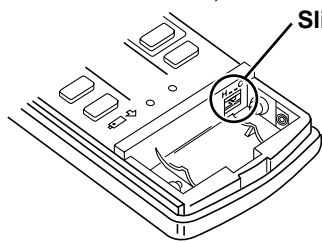

Slide switch

Type	COOL & HEAT	COOL ONLY
The position of the slide switch		

8-4. MU & MUX TYPE / MUH & MXZ TYPE SWITCH OVER AND AUTO RESTART FUNCTION

1. MU & MUX TYPE / MUH & MXZ TYPE SWITCH OVER

The indoor units for MU & MUX type and MUH & MXZ type are common specifications. Set switch according to the type of outdoor unit. The units are set for MUH & MXZ type when they are shipped from the factory.

SW2-① sets the AUTO RESTART FUNCTION ON / OFF.
SW2-② switches over the MU & MUX type / MUH & MXZ type.

When the units are shipped from the factory, SW2 is as follows.
SW2-①: AUTO RESTART FUNCTION ON
SW2-②: MUH & MXZ type

How to switch over MU & MUX TYPE / MUH & MXZ TYPE

- (1) Turn OFF the main power for the unit.
- (2) Pull out the electronic control P.C. board, and change switch(SW2-②) on the indoor electronic control P.C. board according to the type of outdoor unit as following figures.

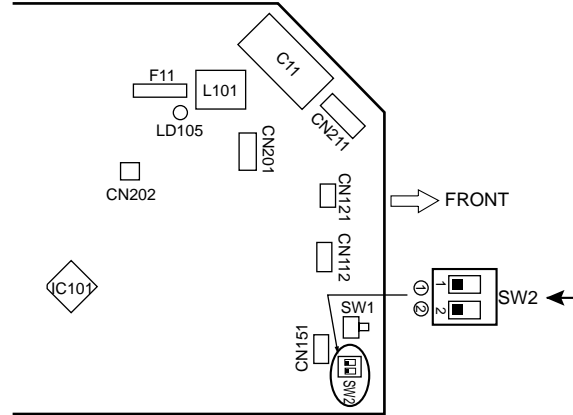

**Outdoor unit
MU & MUX type**
Set ② switch upside.

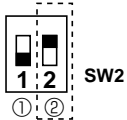

**Outdoor unit
MUH & MXZ type**
Set ② switch downside.

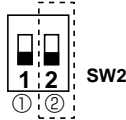

NOTE:•If the indoor-outdoor connecting wire is incorrectly connected on the terminal block, the unit does not operate normally.

•If a ground is incorrect, it may cause an electric shock.

2. AUTO RESTART FUNCTION

When the indoor unit is controlled with the remote controller, the operation mode, set temperature, and the fan speed are memorized by the indoor electronic control P.C. board. The "AUTO RESTART FUNCTION" sets to work the moment power has restored after power failure. Then, the unit will restart automatically. However if the unit is operated in "I FEEL CONTROL" mode before power failure, the operation is not memorized. In "I FEEL CONTROL" mode, the operation is decided by the initial room temperature. "AUTO RESTART FUNCTION" is ON when the units are shipped from the factory.

Operation

- (1) If the main power (230V AC) has been cut, the operation settings remain.
- (2) After the power is restored, the unit restarts automatically according to the memory. (However, it takes at least 3 minutes for the compressor to start running.)

How to release "AUTO RESTART FUNCTION"

- (1) Turn OFF the main power for the unit.
- (2) Pull out the electronic control P.C. board, and change switch(SW2-①) on the indoor electronic control P.C. board as following figures.

**AUTO RESTART
FUNCTION ON**
Set ① switch downside.

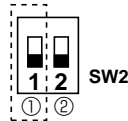

**AUTO RESTART
FUNCTION OFF**
Set ① switch upside.

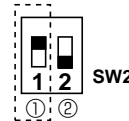

NOTE

- The operation settings are memorized when 10 seconds have passed after the remote controller was operated.
- If main power is cut while AUTO START/STOP timer is active, the timer setting is cancelled.
- If the unit has been off with the remote controller before power failure, the auto restart function does not work as the power button of the remote controller is off.
- To prevent breaker off due to the rush of starting current, systematize other home appliance not to turn ON at the same time.
- When some air conditioners are connected to the same supply system, if they are operated before power failure, the starting current of all the compressors may flow simultaneously at restart. Therefore, the special counter-measures are required to prevent the main voltage-drop or the rush of the starting current by adding system that allows the units to start one by one.

MSC-GA20VB
MSC-GA25VB
MSC-GA35VB

9-1. Cautions on troubleshooting

1. Before troubleshooting, check the following:

- 1) Check the power supply voltage.
- 2) Check the indoor/outdoor connecting wire for mis-wiring.

2. Take care the following during servicing.

- 1) Before servicing the air conditioner, be sure to turn OFF the main unit first with the remote controller, and then after confirming the horizontal vane is closed, turn OFF the breaker and/or disconnect the power plug.
- 2) Be sure to turn OFF the power supply before removing the front panel, the cabinet, the top panel, and the electronic control P.C. board.
- 3) When removing the electronic control P.C. board, hold the edge of the board with care NOT to apply stress on the components.
- 4) When connecting or disconnecting the connectors, hold the housing of the connector. DO NOT pull the lead wires.

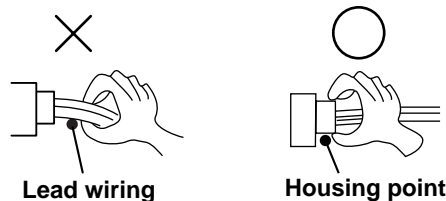

3. Troubleshooting procedure

- 1) First, check if the OPERATION INDICATOR lamp on the indoor unit is flashing on and off to indicate an abnormality. To make sure, check how many times the abnormality indication is flashing on and off before starting service work.
- 2) If the electronic control P.C. board is supposed to be defective, check the copper foil pattern for disconnection and the components for bursting and discoloration.
- 3) When troubleshooting, refer to 9-2. "Instruction of troubleshooting" and 9-3. "Troubleshooting check table".

4. How to replace batteries

Weak batteries may cause the remote controller malfunction.

In this case, replace the batteries to operate the remote controller normally.

- ① Remove the front lid and insert batteries. Then reattach the front lid.

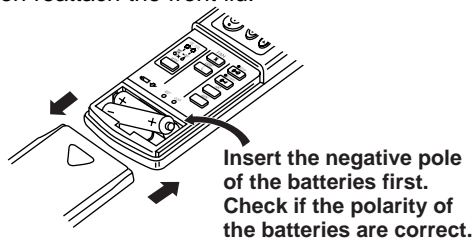

- ② Press the RESET button.

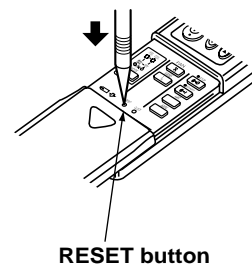

NOTE1 : If the RESET button is not pressed, the remote controller may not operate correctly.

NOTE2 : INFORMATION FOR MULTI SYSTEM AIR CONDITIONER

(OUTDOOR UNIT : MXZ-A14WV MXZ-A18WV MXZ-A26WV MXZ-A32WV)

Multi system air conditioner (Outdoor unit **MXZ-A14WV MXZ-A18WV MXZ-A26WV MXZ-A32WV**) can connect two or more indoor units with one outdoor unit.

According to the capacity, two or more units can operate simultaneously.

- When you try to operate two or more indoor units with one outdoor unit simultaneously, one for the cooling and the other for heating, the operation mode of the indoor unit that operates earlier is selected. The other indoor units that will start the operation later cannot operate, indicating as shown in the figure below. In this case, please set all the indoor units to the same operation mode.

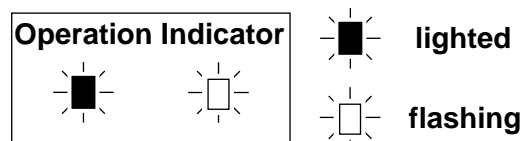

- When indoor units starts the operation while the defrosting of outdoor unit is being done, it takes a few minutes (max. 10 minutes) to blow out the warm air.
- In the heating operation, though indoor unit that does not operate may get warm or the sound of refrigerant flowing may be heard, they are not malfunction. The reason is that the refrigerant continuously flows into it.

9-2. Instruction of troubleshooting
MSC-GA20VB
MSC-GA25VB
MSC-GA35VB

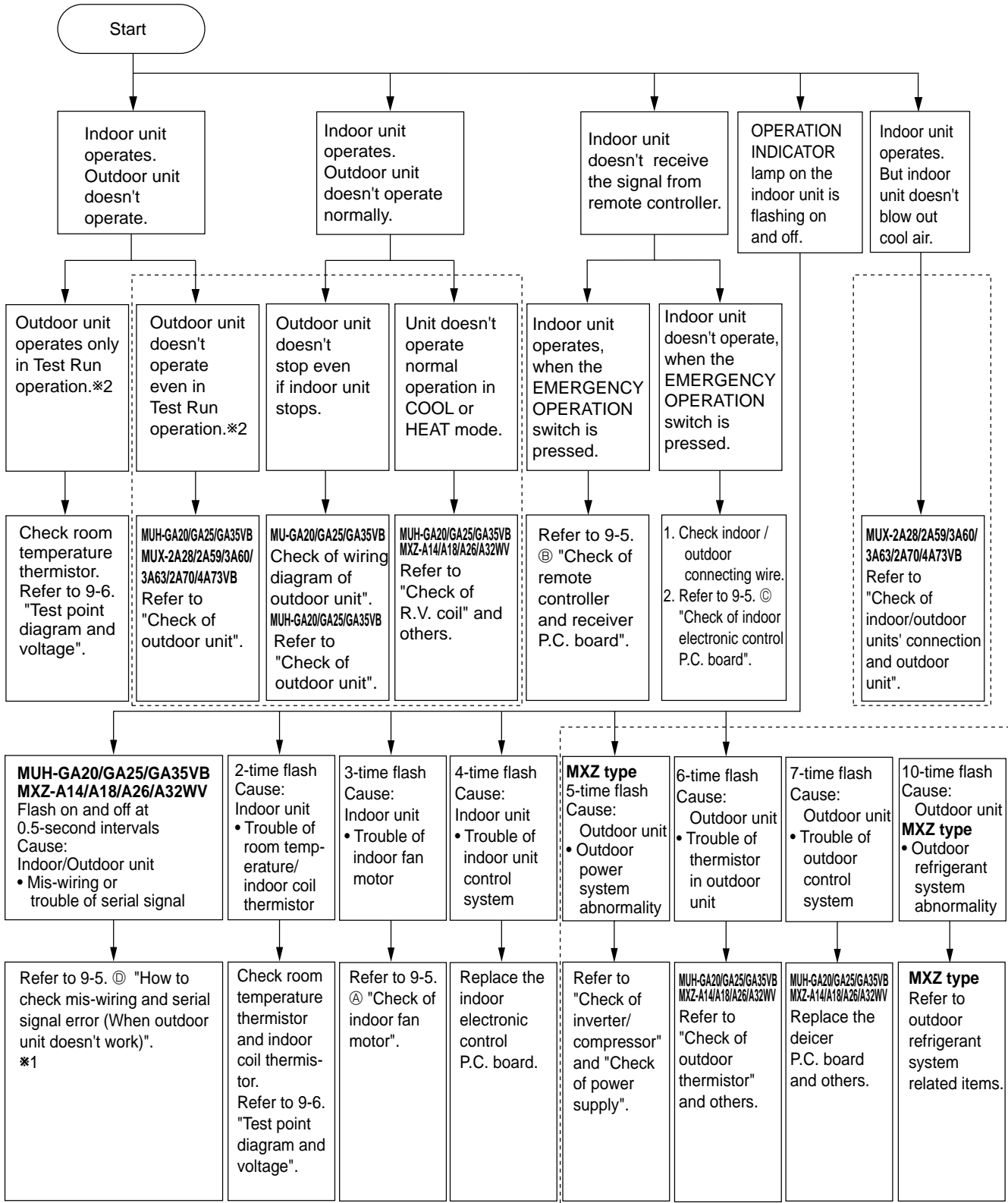

*1.<The case of the trouble of the serial signal>

When the power is turned off and then turned on again, the indication shows "the trouble of mis-wiring".

*2."Test Run operation" means the operation within 30 minutes after EMERGENCY OPERATION switch is pressed.

----- Refer to outdoor unit service manual.

9-3. Troubleshooting check table



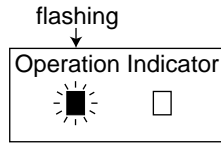



- The following indication does not depend on the shape of lamp.

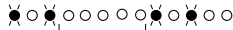
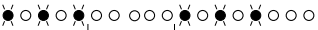

- Flashing of the OPERATION INDICATOR lamp (on the left-hand side) indicates possible abnormalities.
- The OPERATION INDICATOR lamp (on the left-hand side) is lighting during normal operation.

※ Before taking measures, make sure that the symptom reappears, for accurate troubleshooting.

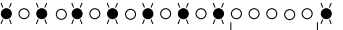
Self check table

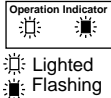
No.	Abnormal point	Operation indicator lamp	Symptom	Detection method	Checkpoint
1	MUH or MXZ type Mis-wiring or Serial signal	0.5-second ON  0.5-second OFF	Outdoor unit does not run.	When serial signal from outdoor unit stops for 4 to 5 seconds.	<ul style="list-style-type: none"> Check switch SW2-②.(MU & MUX type or MUH & MXZ type) Check wiring (visual check and conductivity check). Check indoor electronic control P.C.board. Check outdoor DEICER P.C. board and others. Check electrical parts.
2	Indoor coil thermistor Room temperature thermistor	2-time flash  2.5-second OFF	Outdoor unit does not run.	Detect Indoor coil/room temperature thermistor short or open circuit every 8 seconds during operation.	<ul style="list-style-type: none"> Check resistance of thermistor. Reconnect connector. Check indoor electronic control P.C.board.
3	Indoor fan motor	3-time flash  2.5-second OFF	Indoor fan motor repeats 12 seconds ON and 3 minutes OFF. When the indoor fan motor breaks, the fan keeps stopping.	When rotational frequency feedback pulse signal is not emitted during 12-second indoor fan operation.	<ul style="list-style-type: none"> Disconnect connector CN211 and then check connector CN121 ②-③ to make sure rotational frequency feedback signal of 1.5V or over exists. Check indoor electronic control P.C. board. Check indoor fan motor. Reconnect connector.
4	Indoor control system	4-time flash  2.5-second OFF	Outdoor unit does not operate.	When it cannot properly read data in the nonvolatile memory of indoor electronic control P.C. board.	<ul style="list-style-type: none"> Replace the indoor electronic control P.C. board.
5	MXZ type Outdoor power system	5-time flash  2.5-second OFF	Outdoor unit does not run.	When the compressor operation is continuously three times interrupted by over current protection within 1 minute after start-up, it stops operation.	<ul style="list-style-type: none"> Check the inverter output. Check the compressor.
6	MUH or MXZ type Defrost thermistor	6-time flash  2.5-second OFF	Outdoor unit does not run.	When the defrost thermistor shorts or opens after the compressor start-up.	<ul style="list-style-type: none"> Check outdoor DEICER P.C. board and others. Check resistance of thermistor. Reconnect connector. Refer to outdoor unit service manual.
7	MUH or MXZ type Outdoor control system error	7-time flash  2.5-second OFF	Outdoor unit does not run.	When it cannot properly read data in the non-volatile memory of outdoor electronic control P.C. board.	<ul style="list-style-type: none"> Check outdoor DEICER P.C. board and others. Refer to outdoor unit service manual.
8	MXZ type Outdoor refrigerant system error	10-time flash  2.5-second OFF	Outdoor unit does not run.	When the compressor operation has been interrupted by LEV protection continuously 5 minutes, the compressor stops operation.	<ul style="list-style-type: none"> Refer to "Check of LEV". Check refrigerant circuit and refrigerant amount. Check outdoor electronic control P.C. board. Refer to outdoor unit service manual.
9	MXZ type Operation mode setting	 : Lighted : Flashing 2.5-second OFF	Outdoor unit operates but indoor unit does not run.	When the operation mode of each indoor unit is differently set to COOL(includes DRY) and HEAT at same time, the operation mode of indoor unit that has operated at first has the priority.	<ul style="list-style-type: none"> Unify the operation mode.

9-4. Trouble criterion of main parts

MSC-GA20VB

MSC-GA25VB

MSC-GA35VB

Part name	Check method and criterion	Figure													
Room temperature thermistor (RT11)	Measure the resistance with a tester. (Part temperature 10°C ~ 30°C) <table border="1" style="margin-left: 20px;"> <tr> <td>Normal</td> <td>Abnormal</td> </tr> <tr> <td>MSC-GA20/GA25/GA35VB</td> <td rowspan="2">Open or short-circuit</td> </tr> <tr> <td>8kΩ ~ 20kΩ</td> </tr> </table>	Normal	Abnormal	MSC-GA20/GA25/GA35VB	Open or short-circuit	8kΩ ~ 20kΩ									
Normal		Abnormal													
MSC-GA20/GA25/GA35VB	Open or short-circuit														
8kΩ ~ 20kΩ															
Indoor coil thermistor (RT12)															
Indoor fan motor (MF) INNER FUSE 136±3°C CUT OFF	Measure the resistance between the terminals with a tester. (Coil wiring temperature 10°C ~ 30°C) <table border="1" style="margin-left: 20px;"> <tr> <th rowspan="2">Color of lead wire</th> <th colspan="2">Normal</th> <th rowspan="2">Abnormal</th> </tr> <tr> <th>MSC-GA20/GA25VB</th> <th>MSC-GA35VB</th> </tr> <tr> <td>WHT-BLK</td> <td>271 ~ 295Ω</td> <td>215 ~ 233Ω</td> <td rowspan="2">Open or short-circuit</td> </tr> <tr> <td>BLK-RED</td> <td>180 ~ 196Ω</td> <td>305 ~ 331Ω</td> </tr> </table>	Color of lead wire	Normal		Abnormal	MSC-GA20/GA25VB	MSC-GA35VB	WHT-BLK	271 ~ 295Ω	215 ~ 233Ω	Open or short-circuit	BLK-RED	180 ~ 196Ω	305 ~ 331Ω	
	Color of lead wire		Normal			Abnormal									
MSC-GA20/GA25VB		MSC-GA35VB													
WHT-BLK	271 ~ 295Ω	215 ~ 233Ω	Open or short-circuit												
BLK-RED	180 ~ 196Ω	305 ~ 331Ω													
Motor part	Measure the voltage Power ON. <table border="1" style="margin-left: 20px;"> <tr> <th rowspan="2">Color of lead wire</th> <th>Normal</th> <th rowspan="2">Abnormal</th> </tr> <tr> <th>MSC-GA20/GA25/GA35VB</th> </tr> <tr> <td>BRN-YLW</td> <td>4.5 ~ 5.5V</td> <td rowspan="2">Remain 0V or 5V</td> </tr> <tr> <td>YLW-GRY</td> <td>(When fan revolved one time) 0V→5V→0V (Approx.)</td> </tr> </table>	Color of lead wire	Normal	Abnormal	MSC-GA20/GA25/GA35VB	BRN-YLW	4.5 ~ 5.5V	Remain 0V or 5V	YLW-GRY	(When fan revolved one time) 0V→5V→0V (Approx.)					
Color of lead wire	Normal		Abnormal												
	MSC-GA20/GA25/GA35VB														
BRN-YLW	4.5 ~ 5.5V	Remain 0V or 5V													
YLW-GRY	(When fan revolved one time) 0V→5V→0V (Approx.)														
Sensor part															
Vane motor (MV)	Measure the resistance between the terminals with a tester. (Part temperature 10°C ~ 30°C) <table border="1" style="margin-left: 20px;"> <tr> <td>Normal</td> <td>Abnormal</td> </tr> <tr> <td>MSC-GA20/GA25/GA35VB</td> <td rowspan="2">Open or short-circuit</td> </tr> <tr> <td>240 ~ 260Ω</td> </tr> </table>	Normal	Abnormal	MSC-GA20/GA25/GA35VB	Open or short-circuit	240 ~ 260Ω									
Normal	Abnormal														
MSC-GA20/GA25/GA35VB	Open or short-circuit														
240 ~ 260Ω															

9-5. Troubleshooting flow

When OPERATION INDICATOR lamp flashes 3-time.
Indoor fan motor doesn't operate.

Ⓐ Check of indoor fan motor

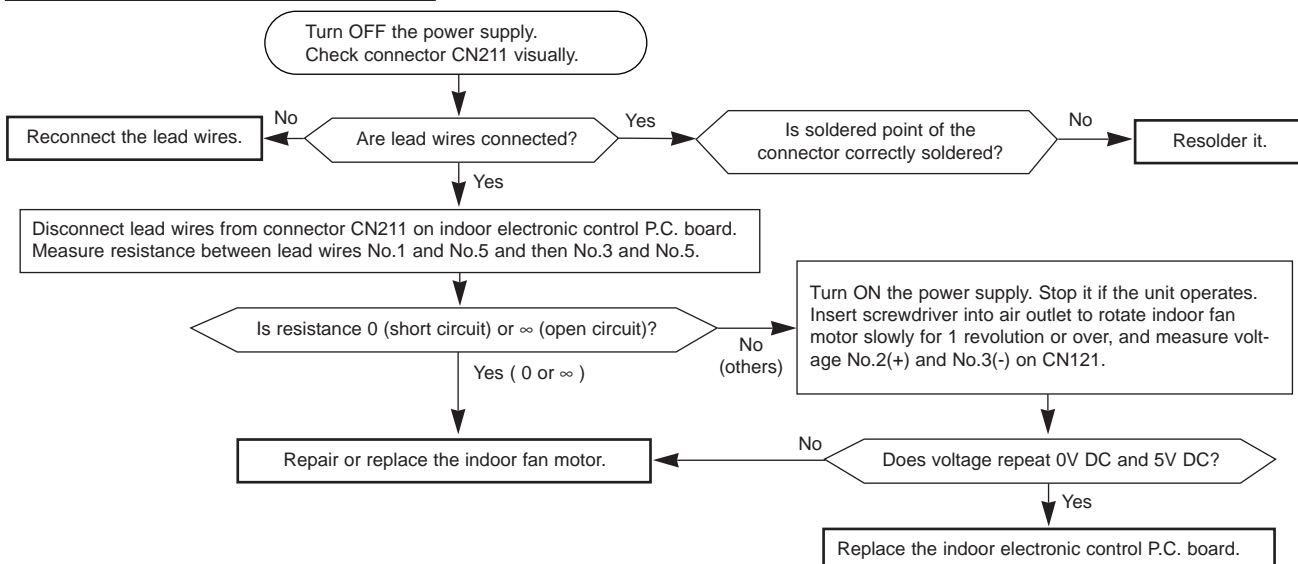

Indoor unit operates by pressing the EMERGENCY OPERATION switch, but doesn't operate with the remote controller.

Ⓑ Check of remote controller and receiver P.C. board

※Check the remote controller is exclusive for this air conditioner.

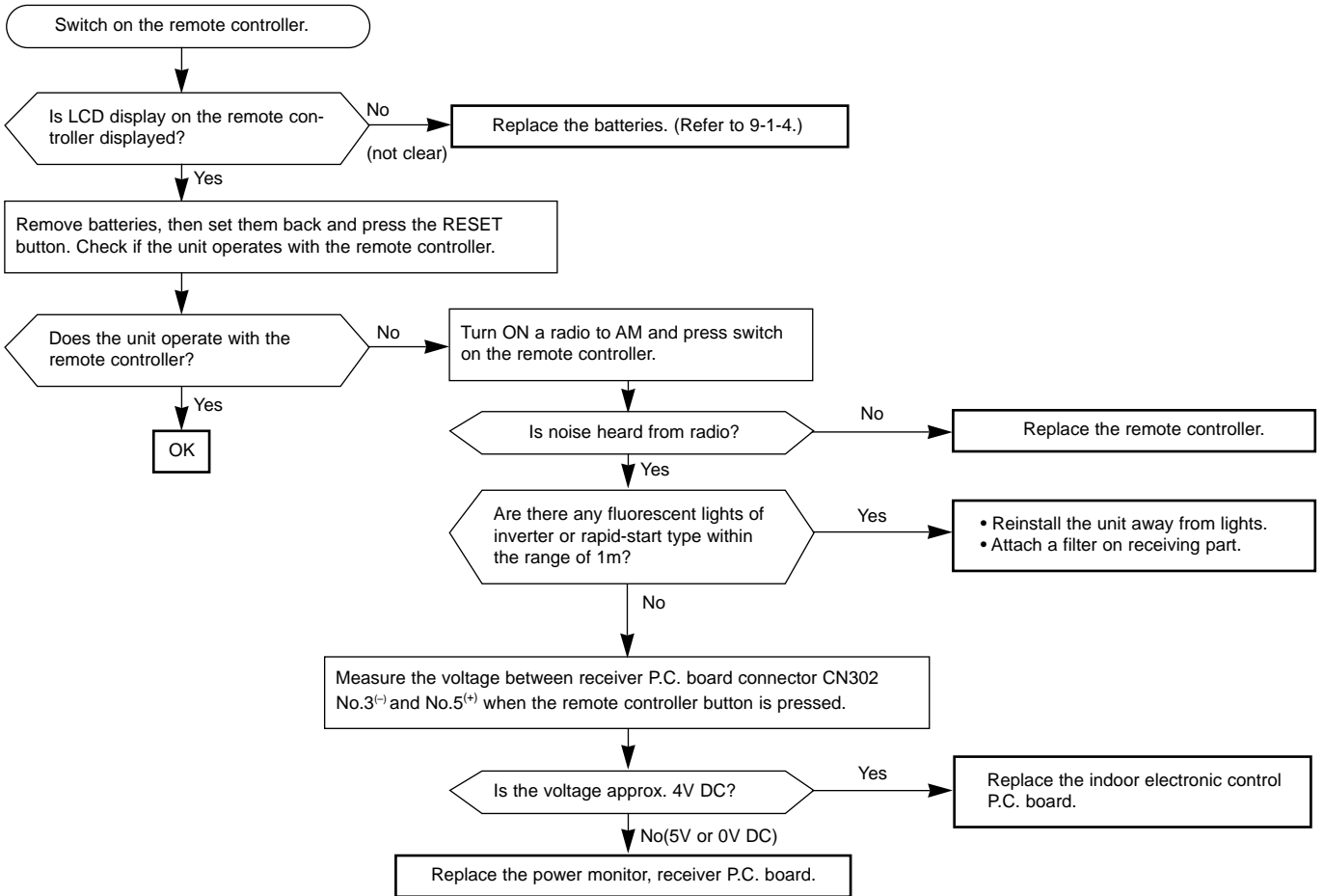

The unit doesn't operate with the remote controller.

Also, the OPERATION INDICATOR lamp doesn't light up by pressing the EMERGENCY OPERATION switch.

Ⓒ Check of indoor electronic control P.C. board

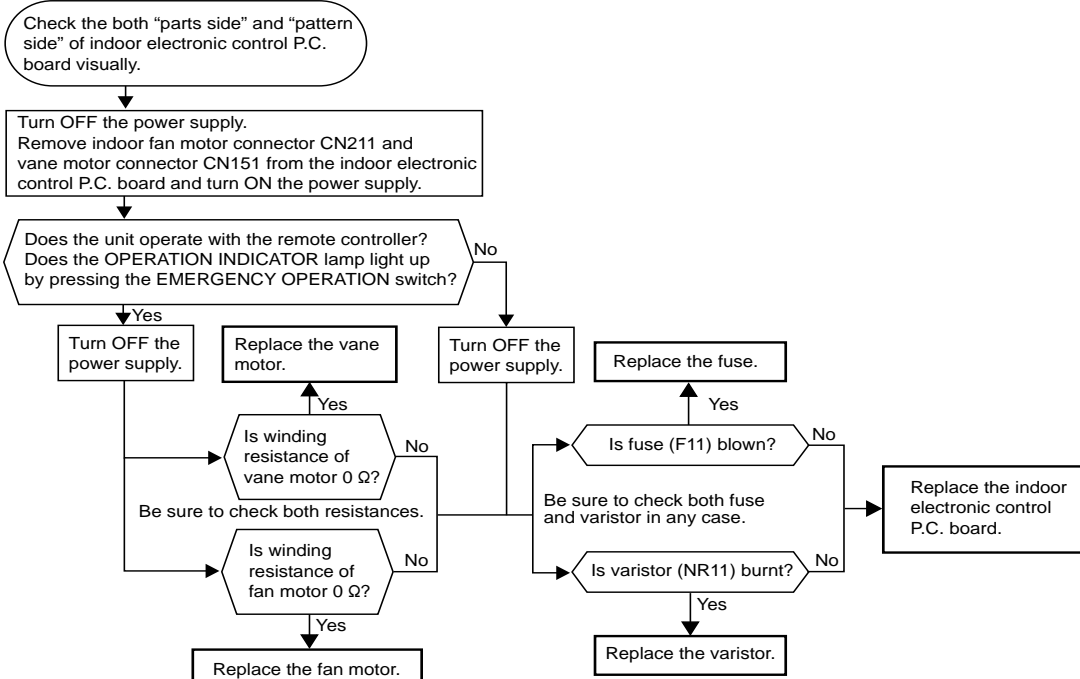

When OPERATION INDICATOR lamp flashes 0.5-second intervals or 1-time.
Outdoor unit does not operate.

ⓐ How to check mis-wiring and serial signal error

<MUH-GA20/GA25/GA35VB, MXZ-A14/A18/A26/A32WV>

- ※ 1 Set the switch(SW2-②) on indoor electronic control P.C. board to MU or MUX type, when the outdoor unit is MU or MUX type. If the setting is MUH or MXZ type, the unit does not work.
- ※ 2 Short circuit of JPG and JPS on the indoor electronic control P.C. board enables self-check to be displayed in 3 seconds.

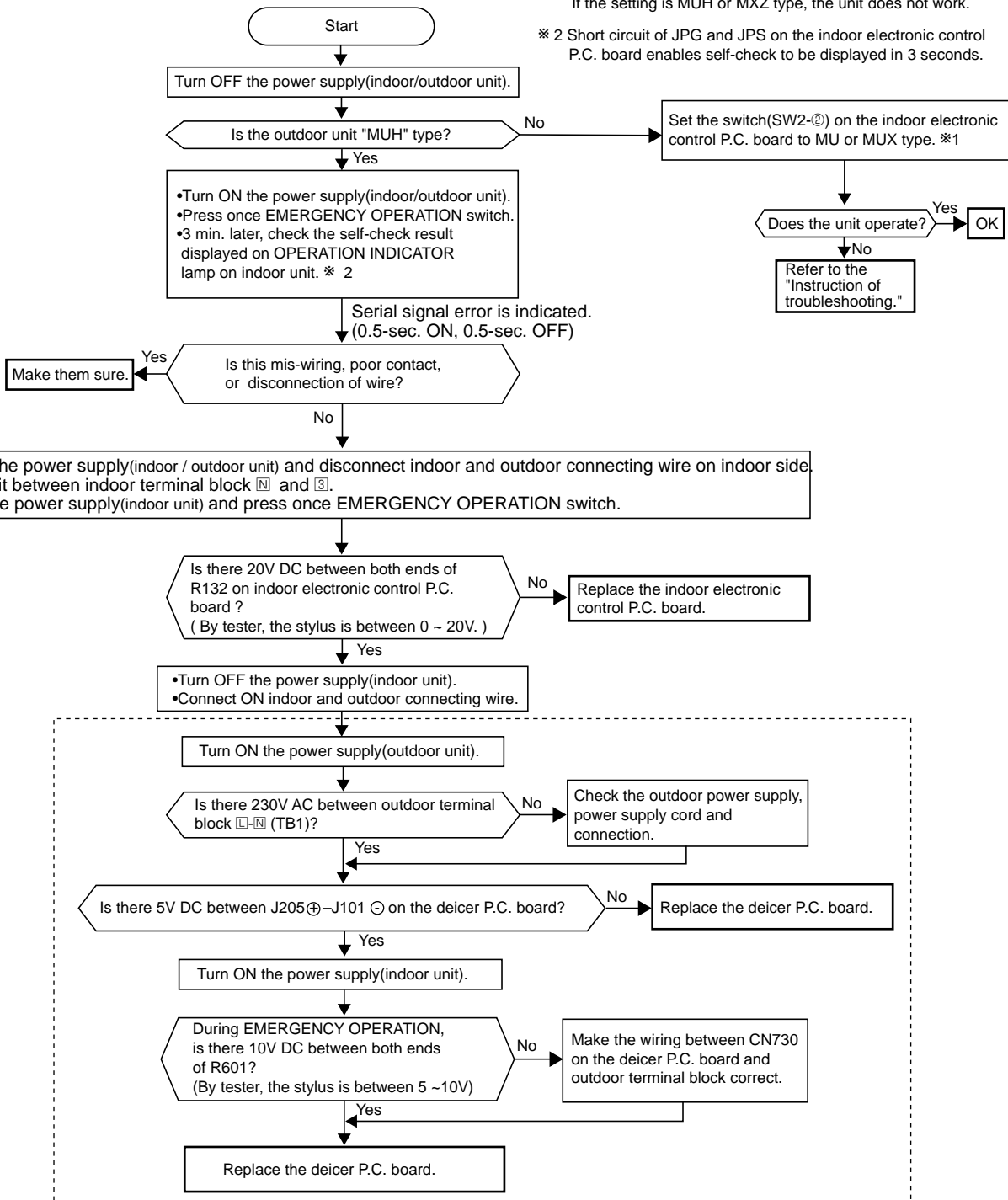

Refer to outdoor unit service manual.

9-6. Test point diagram and voltage

MSC-GA20VB

MSC-GA25VB

MSC-GA35VB

Indoor electronic control P.C. board

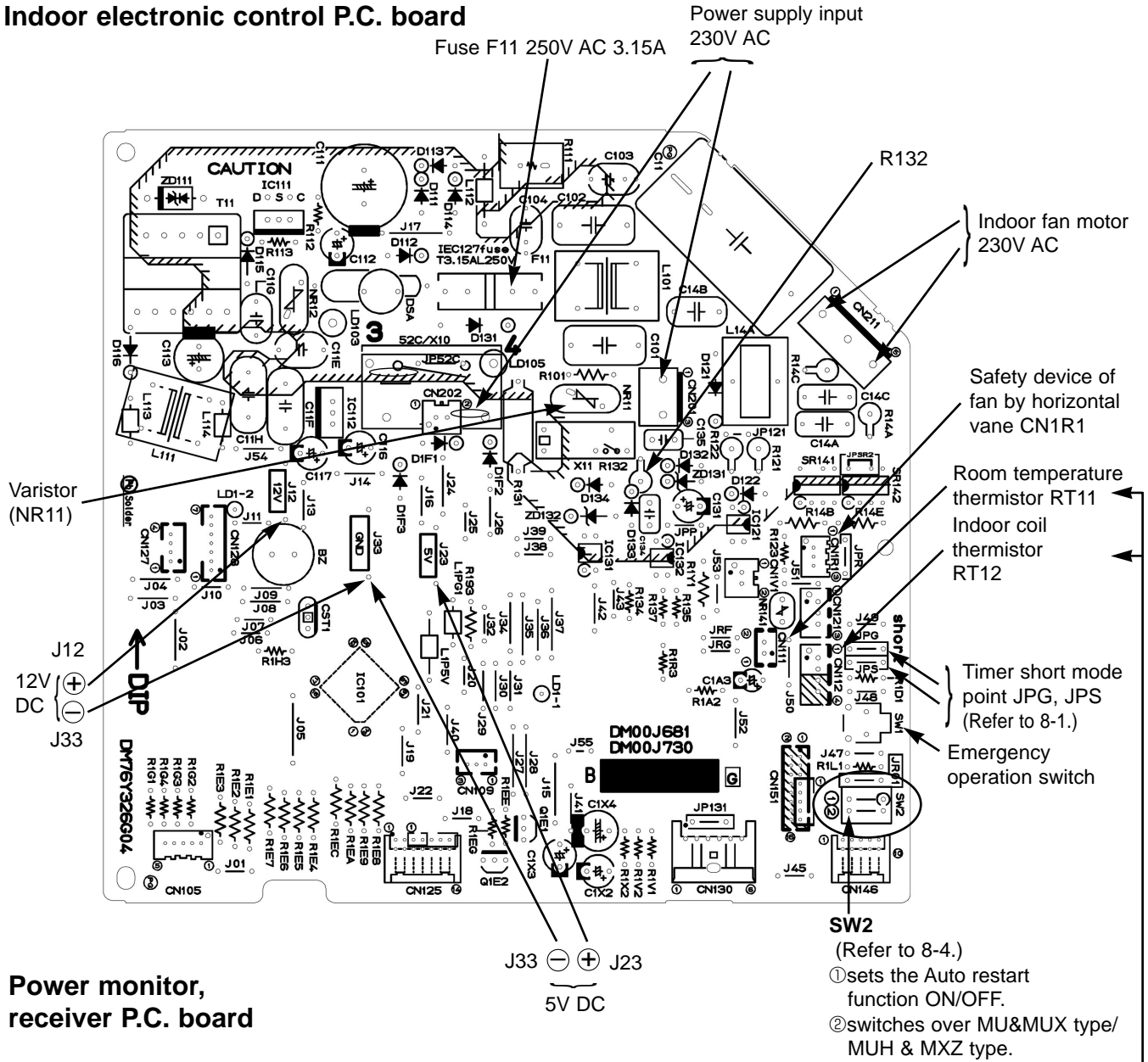

Power monitor, receiver P.C. board

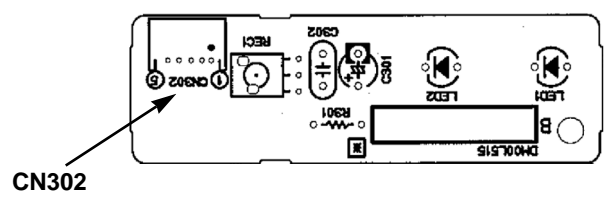

Indoor coil thermistor (RT12)
Room temperature thermistor (RT11)

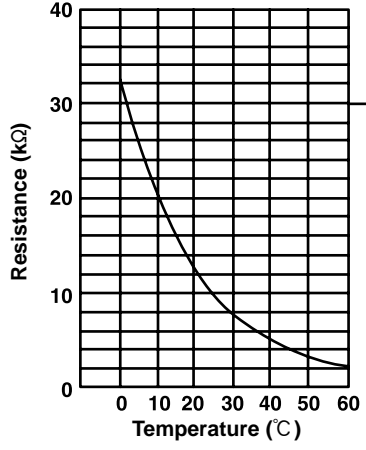

<"Terminal with locking mechanism" Detaching points>

The terminal which has the locking mechanism can be detached as shown below.
There are two types (Refer to (1) and (2)) of the terminal with locking mechanism.
The terminal without locking mechanism can be detached by pulling it out.
Check the shape of the terminal before detaching.

(1) Slide the sleeve and check if there is a locking lever or not.

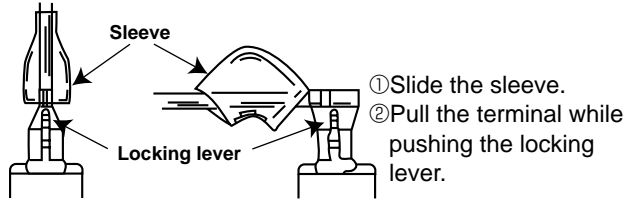

(2) The terminal with this connector has the locking mechanism.

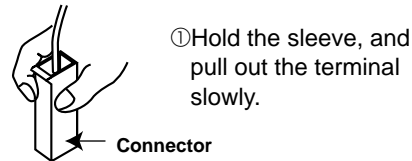

MSC-GA20VB MSC-GA25VB MSC-GA35VB

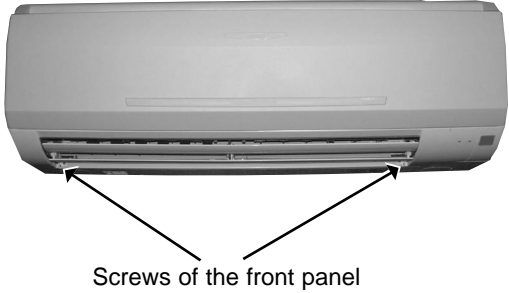
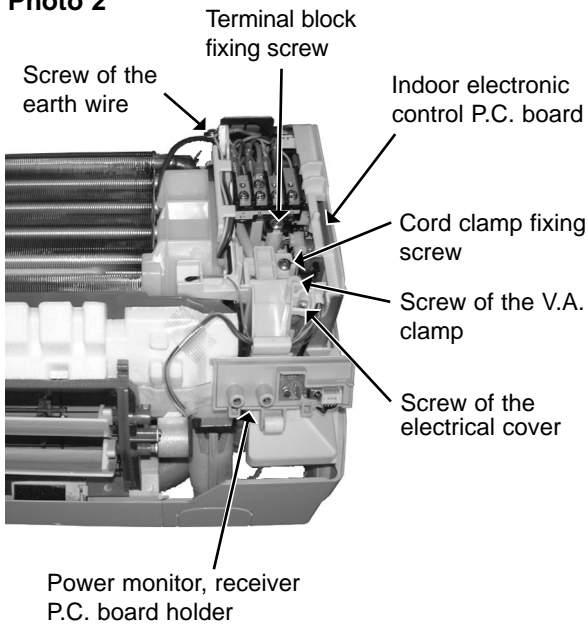
OPERATING PROCEDURE	PHOTOS
<p>1. Removing the front panel</p> <p>(1) Remove the screw caps of the front panel. Remove the screws.</p> <p>(2) Pull the panel down to your side slightly and unhook the catches at the top.</p>	<p>Photo 1</p> 
<p>2. Removing the electronic control P.C. board and the power monitor, receiver P.C. board</p> <p>NOTE : In case of removing only indoor electronic control P.C. board, work (3) is not necessary.</p> <p>(1) Remove the front panel. (Refer to 1.)</p> <p>(2) Remove the power monitor, receiver P.C. board holder from the bottom of electrical box.</p> <p>(3) Open the power monitor, receiver P.C. board holder and remove the power monitor, receiver P.C. board.</p> <p>(4) Remove the screw of the electrical cover and the electrical cover.</p> <p>(5) Remove the screw of the V.A. clamp and the V.A. clamp.</p> <p>(6) Remove the screw of the cord clamp and the cord clamp.</p> <p>(7) Remove the screw of the terminal block.</p> <p>(8) Remove the screw of the earth wire.</p> <p>(9) Pull out indoor electronic control P.C. board slightly.</p> <p>(10) Disconnect all (except CN101) the connectors on the electronic control P.C. board.</p> <p>(11) Remove the electronic control P.C. board.</p> <p>(12) Disconnect the connector of power monitor, receiver P.C. board (CN101) on the electronic control P.C. board.</p>	<p>Photo 2</p> 



OPERATING PROCEDURE

3. Removing the electrical box

- (1) Remove the front panel. (Refer to 1.)
- (2) Remove the electrical cover. (Refer to 2.)
- (3) Remove the V.A. clamp. (Refer to 2.)
- (4) Remove the cord clamp. (Refer to 2.)
- (5) Remove the terminal block. (Refer to 2.)
- (6) Remove the screw of earth wire. (Refer to 2.)
- (7) Disconnect the connector of the indoor coil thermistor (CN112), the fan motor connector (CN211 and CN121) and the vane motor connector (CN151) on the electronic control P.C. board.
- (8) Remove the fan motor lead wire and indoor coil thermistor from the electrical box.
- (9) Remove the lead wire of vane motor from the bottom of electrical box.
- (10) Remove the screw fixing the electrical box, remove the electrical box.

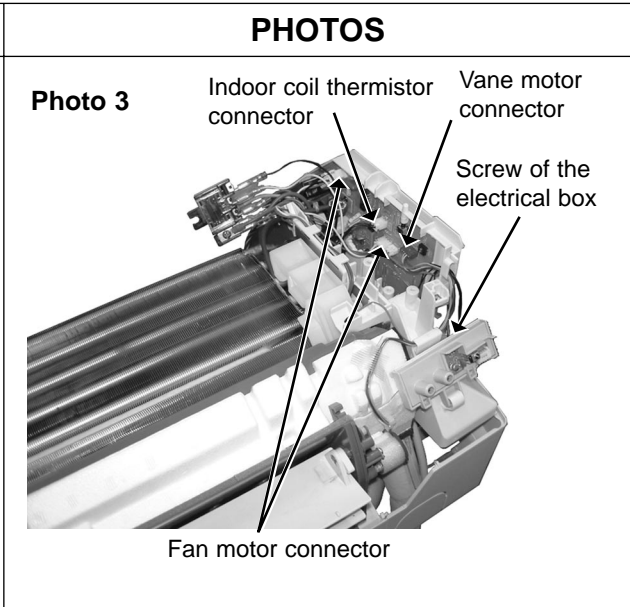

4. Removing the nozzle assembly and the vane motor

- (1) Remove the front panel. (Refer to 1.)
- (2) Remove the electrical box. (Refer to 3.)
- (3) Pull out the drain hose from the nozzle assembly, remove the nozzle assembly.
- (4) Remove the screws of the vane motor, disconnect the vane motor connector.
- (5) Remove the vane motor.

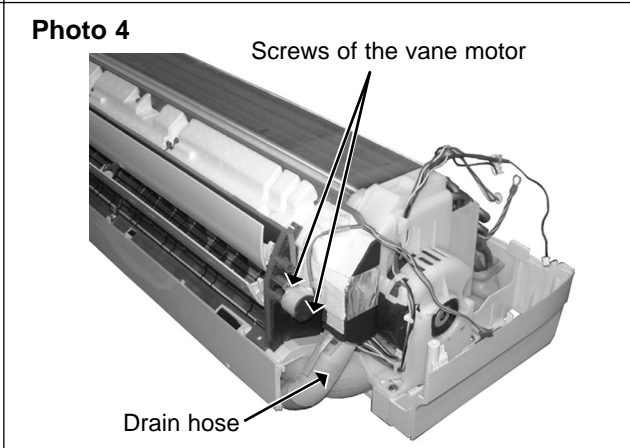

5. Removing the indoor fan motor and the line flow fan

- (1) Remove the front panel. (Refer to 1.)
- (2) Remove the electrical box. (Refer to 3.)
- (3) Pull out the drain hose from the nozzle assembly, remove the nozzle assembly. (Refer to 4.)
- (4) Remove the screw of the lead cover and lead cover.
- (5) Release the hooks to open the motor band slightly.
- (6) Loosen the hexagon socket set screw from the line flow fan.
- (7) Remove the screws fixing the motor bed, remove the fan motor with motor band and the motor bed.
- (8) Remove the screws fixing the left side of the heat exchanger.
- (9) Lift the left side of the heat exchanger.
- (10) Remove the line flow fan.

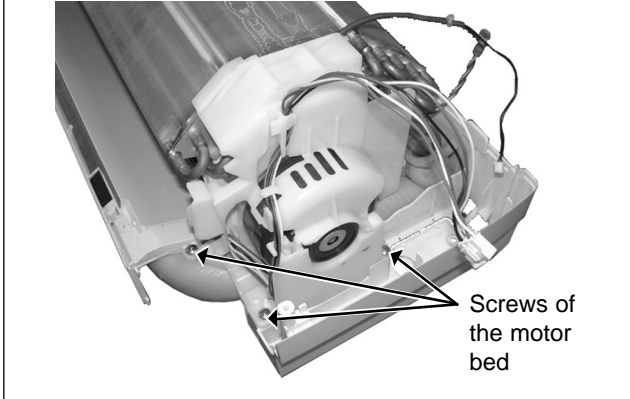
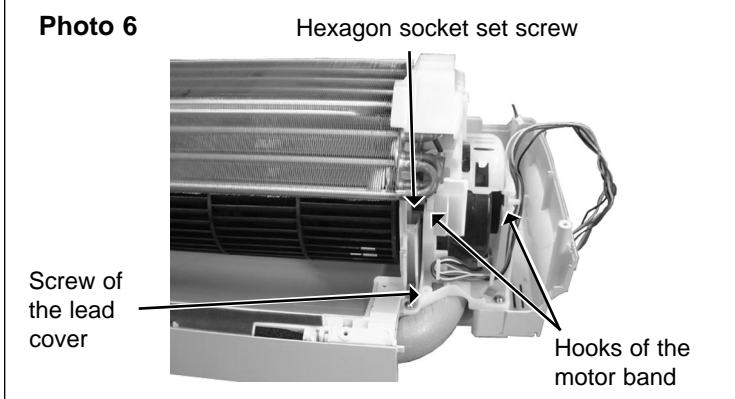
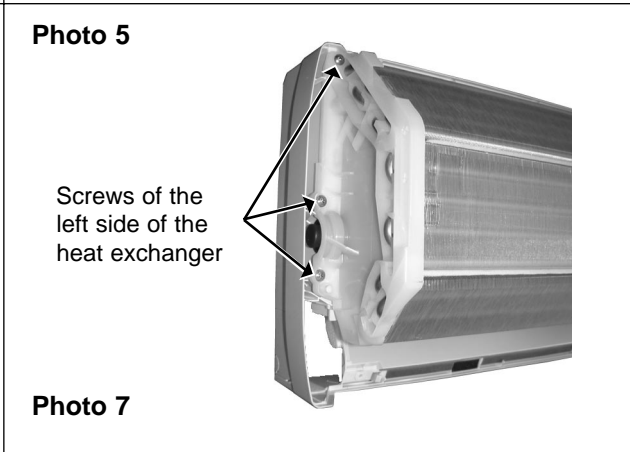

MSC-GA20VB
MSC-GA25VB
MSC-GA35VB

11-1. INDOOR UNIT STRUCTURAL PARTS

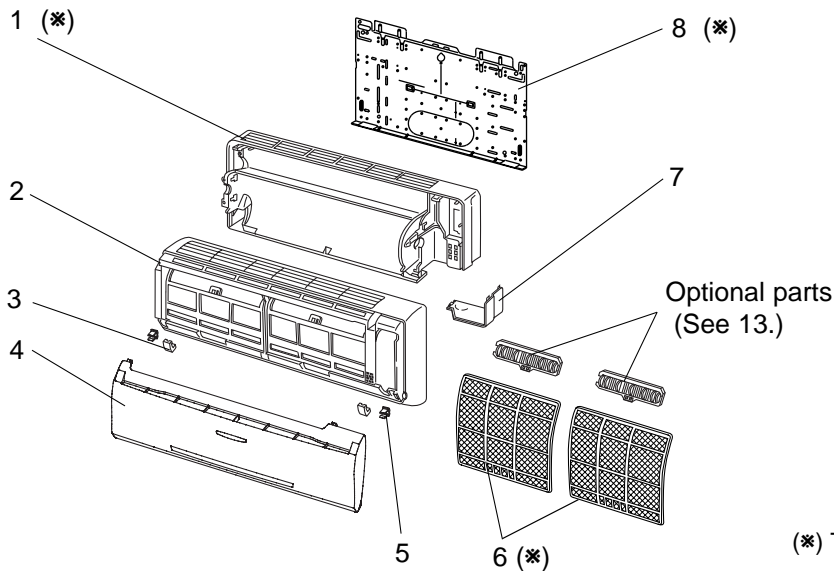

11-2. ACCESSORY AND REMOTE CONTROLLER

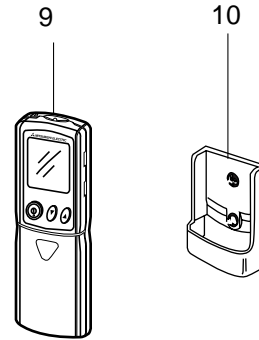

(*) These figures show about MSC-GA35VB.

11-1. INDOOR UNIT STRUCTURAL PARTS

No.	Part No.	Part Name	Symbol in Wiring Diagram	Q'ty/unit			Remarks
				MSC-GA20VB- E1	MSC-GA25VB- E1	MSC-GA35VB- E1	
1	E02 763 234	BOX		1	1		
	E02 764 234	BOX				1	
2	E02 959 000	PANEL ASSEMBLY		1	1	1	Including No.3,4,5
3	E02 763 067	SCREW CAP		2	2	2	2PCS/SET
4	E02 959 010	FRONT PANEL		1	1	1	
5	E02 408 142	CATCH		2	2	2	2PCS/SET
6	E02 763 100	CATECHIN AIR FILTER		2	2		1PCE/SET
	E02 764 100	CATECHIN AIR FILTER				2	1PCE/SET
7	E02 763 975	CORNER BOX (RIGHT)		1	1	1	
8	E02 408 970	INSTALLATION PLATE		1	1		
	E02 751 970	INSTALLATION PLATE				1	

11-2. ACCESSORY AND REMOTE CONTROLLER

9	E02 749 426	REMOTE CONTROLLER		1	1	1	KM04F
10	E02 527 083	REMOTE CONTROLLER HOLDER		1	1	1	

PARTS LIST (non-RoHS compliant)

MSC-GA20VB MSC-GA25VB MSC-GA35VB

11-3. INDOOR UNIT ELECTRICAL PARTS AND FUNCTIONAL PARTS

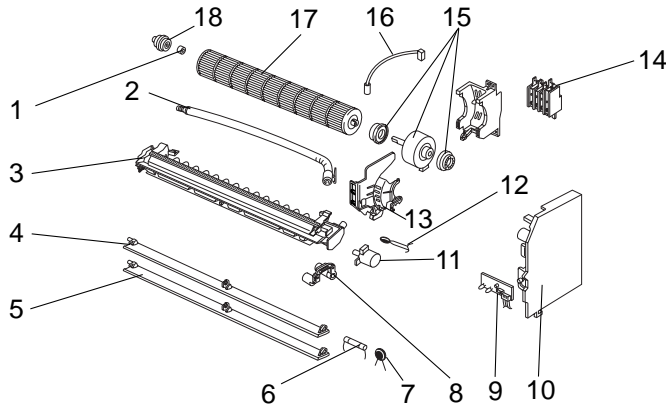

11-4. INDOOR UNIT HEAT EXCHANGER

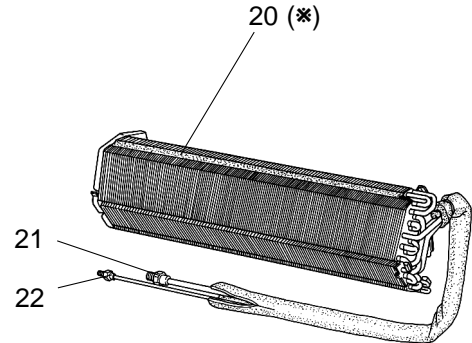

(* This figure shows MSC-GA35VB.

11-3. INDOOR UNIT ELECTRICAL PARTS AND FUNCTIONAL PARTS

Part number that is circled is not shown in the illustration.

No.	Part No.	Part Name	Symbol in Wiring Diagram	Q'ty/unit			Remarks
				MSC-GA20VB- E1	MSC-GA25VB- E1	MSC-GA35VB- E1	
1	E02 001 504	SLEEVE BEARING		1	1	1	
2	E02 661 702	DRAIN HOSE		1	1	1	
3	E02 749 235	NOZZLE ASSEMBLY		1	1	1	
4	E02 781 040	VANE UPPER		1	1	1	
5	E02 781 041	VANE LOWER		1	1	1	
6	E02 127 382	FUSE	F11	1	1	1	3.15A
7	E02 829 385	VARISTOR	NR11	1	1	1	
8	E02 763 034	VANE CRANK SET		1	1	1	
9	E02 815 468	POWER MONITOR, RECEIVER P.C. BOARD		1	1	1	
10	E02 962 452	ELECTRONIC CONTROL P.C.BOARD		1			AUTO RESTART
	E02 963 452	ELECTRONIC CONTROL P.C.BOARD			1		AUTO RESTART
	E02 964 452	ELECTRONIC CONTROL P.C.BOARD				1	AUTO RESTART
11	E02 749 303	VANE MOTOR	MV	1	1	1	
12	E02 151 308	ROOM TEMPERATURE THERMISTOR	RT11	1	1	1	
13	E02 749 333	MOTOR BAND		1	1	1	
14	E02 691 375	TERMINAL BLOCK	TB	1	1	1	3P
15	E02 749 300	INDOOR FAN MOTOR(RC4V19-□□)	MF	1	1		Including fan motor rubber mount 2PCS/SET
	E02 751 300	INDOOR FAN MOTOR(RC4V19-□□)	MF			1	Including fan motor rubber mount 2PCS/SET
16	E02 749 307	INDOOR COIL THERMISTOR	RT12	1	1	1	
18	E02 749 302	LINE FLOW FAN		1	1	1	
	E02 408 509	BEARING MOUNT		1	1		
	E02 751 509	BEARING MOUNT				1	
19	E02 749 385	VARISTOR	NR12	1	1	1	

11-4. INDOOR UNIT HEAT EXCHANGER

20	E02 749 620	INDOOR HEAT EXCHANGER		1	1		
	E02 751 620	INDOOR HEAT EXCHANGER				1	
21	E02 151 666	UNION(GAS)		1	1		φ9.52
	E02 815 666	UNION(GAS)				1	φ9.52
22	E02 151 667	UNION(LIQUID)		1	1	1	φ6.35

MSC-GA20VB
MSC-GA25VB
MSC-GA35VB

12-1. INDOOR UNIT STRUCTURAL PARTS

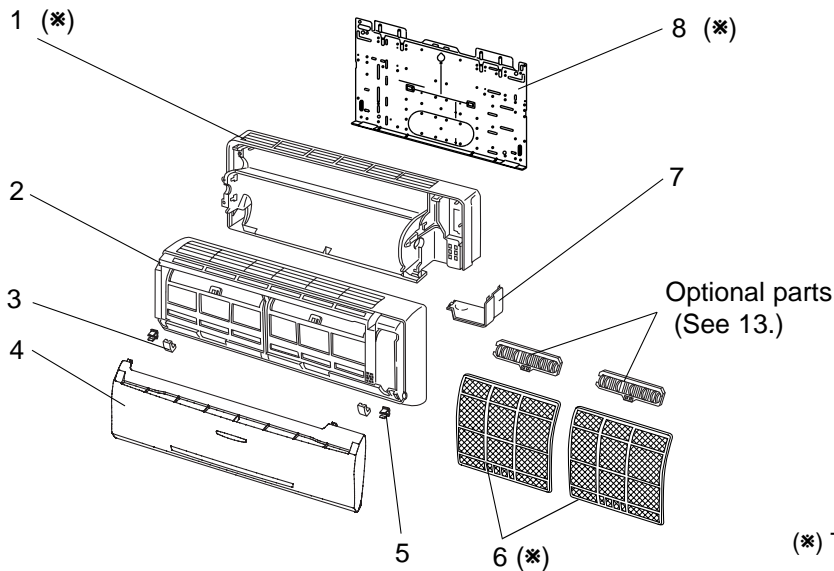

12-2. ACCESSORY AND REMOTE CONTROLLER

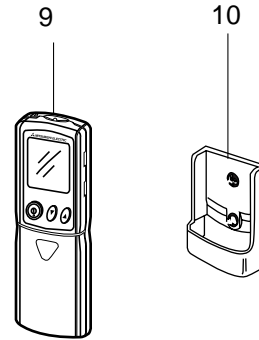

(*) These figures show about MSC-GA35VB.

12-1. INDOOR UNIT STRUCTURAL PARTS

No.	RoHS	Part No.	Part Name	Symbol in Wiring Diagram	Q'ty/unit			Remarks
					MSC-GA20VB- E1	MSC-GA25VB- E1	MSC-GA35VB- E1	
1	G	E12 763 234	BOX		1	1		
	G	E12 764 234	BOX				1	
2	G	E12 959 000	PANEL ASSEMBLY		1	1	1	Including No.3,4,5
3	G	E12 763 067	SCREW CAP		2	2	2	2PCS/SET
4	G	E12 959 010	FRONT PANEL		1	1	1	
5	G	E12 408 142	CATCH		2	2	2	2PCS/SET
6	G	E12 763 100	CATECHIN AIR FILTER		2	2		1PCE/SET
	G	E12 764 100	CATECHIN AIR FILTER				2	1PCE/SET
7	G	E12 763 975	CORNER BOX (RIGHT)		1	1	1	
8	G	E12 408 970	INSTALLATION PLATE		1	1		
	G	E12 751 970	INSTALLATION PLATE				1	

12-2. ACCESSORY AND REMOTE CONTROLLER

9	G	E12 749 426	REMOTE CONTROLLER		1	1	1	KM04F
10	G	E12 527 083	REMOTE CONTROLLER HOLDER		1	1	1	

ROHS PARTS LIST (RoHS compliant)

MSC-GA20VB MSC-GA25VB MSC-GA35VB

12-3. INDOOR UNIT ELECTRICAL PARTS AND FUNCTIONAL PARTS

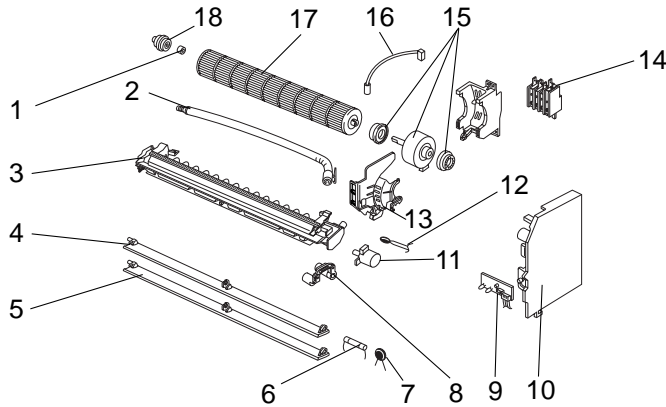

12-4. INDOOR UNIT HEAT EXCHANGER

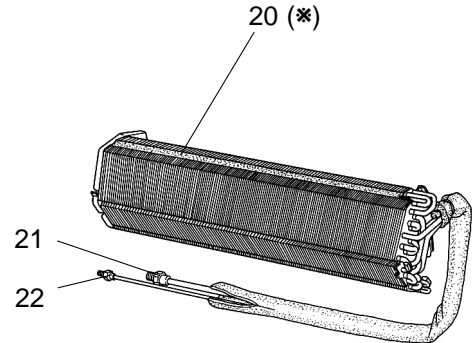

(*) This figure shows MSC-GA35VB.

12-3. INDOOR UNIT ELECTRICAL PARTS AND FUNCTIONAL PARTS

Part number that is circled is not shown in the illustration.

No.	ROHS	Part No.	Part Name	Symbol in Wiring Diagram	Q'ty/unit			Remarks
					MSC-GA20VB- E1	MSC-GA25VB- E1	MSC-GA35VB- E1	
1	G	E12 001 504	SLEEVE BEARING		1	1	1	
2	G	E12 897 702	DRAIN HOSE		1	1	1	
3	G	E12 A59 235	NOZZLE ASSEMBLY		1	1	1	
4	G	E12 781 040	VANE UPPER		1	1	1	
5	G	E12 781 041	VANE LOWER		1	1	1	
6	G	E12 A49 382	FUSE	F11	1	1	1	T3.15AL250V
7	G	E12 829 385	VARISTOR	NR11	1	1	1	
8	G	E12 763 034	VANE CRANK SET		1	1	1	
9	G	E12 815 468	POWER MONITOR, RECEIVER P.C. BOARD		1	1	1	
10	G	E12 962 452	ELECTRONIC CONTROL P.C.BOARD		1			AUTO RESTART
	G	E12 963 452	ELECTRONIC CONTROL P.C.BOARD			1		AUTO RESTART
	G	E12 964 452	ELECTRONIC CONTROL P.C.BOARD				1	AUTO RESTART
11	G	E12 749 303	VANE MOTOR	MV	1	1	1	
12	G	E12 151 308	ROOM TEMPERATURE THERMISTOR	RT11	1	1	1	
13	G	E12 749 333	MOTOR BAND		1	1	1	
14	G	E12 691 375	TERMINAL BLOCK	TB	1	1	1	3P
15	G	E12 749 300	INDOOR FAN MOTOR(RC4V19-□□)	MF	1	1		Including fan motor rubber mount 2PCS/SET
	G	E12 751 300	INDOOR FAN MOTOR(RC4V19-□□)	MF			1	Including fan motor rubber mount 2PCS/SET
16	G	E12 749 307	INDOOR COIL THERMISTOR	RT12	1	1	1	
17	G	E12 A59 302	LINE FLOW FAN		1	1	1	
18	G	E12 408 509	BEARING MOUNT		1	1		
	G	E12 751 509	BEARING MOUNT				1	
19	G	E12 749 385	VARISTOR	NR12	1	1	1	

12-4. INDOOR UNIT HEAT EXCHANGER

20	G	E12 A59 620	INDOOR HEAT EXCHANGER		1	1		
	G	E12 A61 620	INDOOR HEAT EXCHANGER				1	
21	G	E12 151 666	UNION(GAS)		1	1	1	φ9.52
22	G	E12 151 667	UNION(LIQUID)		1	1	1	φ6.35

AIR CLEANING FILTER

- AIR CLEANING FILTER removes fine dust of 0.01 micron from air by means of static electricity.
- Normal life of AIR CLEANING FILTER is 4 months. However, when it becomes dirty, replace it as soon as possible.
- Clogged AIR CLEANING FILTER may reduce the air conditioner capacity or cause frost on the air outlet.
- DO NOT reuse AIR CLEANING FILTER even if it is washed.
- DO NOT remove or attach AIR CLEANING FILTER during unit operation.

Model	Part No.
MSC-GA20VB	MAC-1300FT
MSC-GA25VB	
MSC-GA35VB	

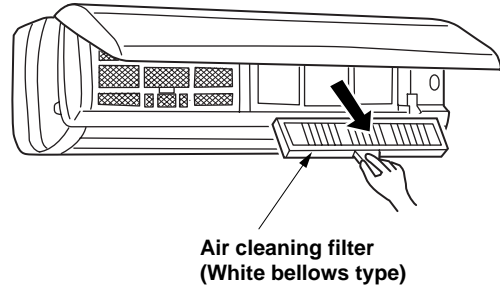

 **MITSUBISHI ELECTRIC CORPORATION**

HEAD OFFICE: TOKYO BLDG., 2-7-3, MARUNOUCHI, CHIYODA-KU, TOKYO 100-8310, JAPAN