



SERVICE MANUAL

Wireless type
Models

MUCF-A18WV - [E1]

MUCF-A24WV - [E1]

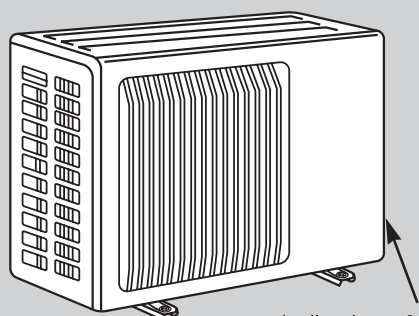

Indication of model name

MUCF-A18WV - [E1]

MUCF-A24WV - [E1]

CONTENTS

1. TECHNICAL CHANGES	2
2. PART NAMES AND FUNCTIONS	5
3. SPECIFICATION	5
4. NOISE CRITERIA CURVES	6
5. OUTLINES AND DIMENSIONS	7
6. WIRING DIAGRAM	8
7. REFRIGERANT SYSTEM DIAGRAM	9
8. PERFORMANCE CURVES	11
9. TROUBLESHOOTING	17
10. DISASSEMBLY INSTRUCTIONS	19
11. PARTS LIST	23

NOTE:

•This service manual describes technical data of outdoor units.
As for indoor units MCF-A18WV-[E1] and MCF-A24WV-[E1], refer to the service manual OB338.



<"Terminal with lock mechanism" Detaching points>

In case of terminal with lock mechanism, detach the terminal as shown below.
There are two types (Refer to (1) and (2)) of the terminal with lock mechanism.
The terminal with no lock mechanism can be removed by pulling it out.
Check the shape of the terminal and work.

(1) Slide the sleeve and check if there is a locking lever or not.

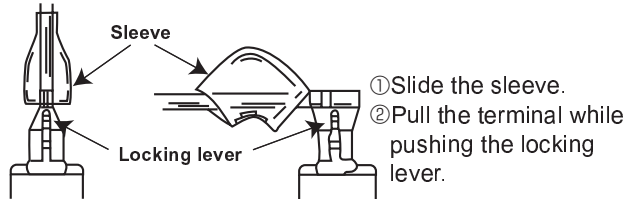

(2) The terminal with this connector is a terminal with lock mechanism

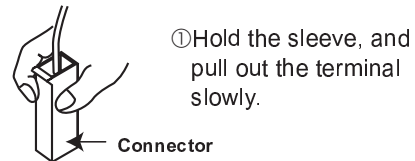

10-1. MUCF-A18WV -[E1] OUTDOOR UNIT

OPERATING PROCEDURE	PHOTOS
<p>1. Removing the cabinet</p> <p>(1) Remove the screws of the cabinet. (2) Hold the down of the cabinet on the both side and remove the cabinet.</p> <p>Photo 2</p> <p>Screws of the cabinet</p>	<p>Photo 1</p> <p>Service panel</p> <p>Screws of the cabinet</p>
<p>2. Removing the electrical parts</p> <p>(1) Remove the service panel and the cabinet. (2) Remove the following parts.</p> <ul style="list-style-type: none"> •Compressor capacitor (C1) •Outdoor fan capacitor (C2) •Terminal block (TB1, TB2) •Compressor contactor (52C) 	<p>Photo 3</p> <p>Outdoor fan capacitor(C2)</p> <p>Connector</p> <p>Compressor contactor(52C)</p> <p>Compressor capacitor(C1)</p> <p>Terminal blocks (TB1, TB2)</p>

OPERATING PROCEDURE

3. Removing the outdoor fan motor

- (1) Remove the cabinet. (Refer to 1.)
- (2) Disconnect the connector and remove the hooked lead wire from the fan motor.
- (3) Remove the propeller nut and remove the propeller.
- (4) Remove screws fixing the outdoor fan motor.
- (5) Remove the outdoor fan motor.

PHOTOS

Photo 4

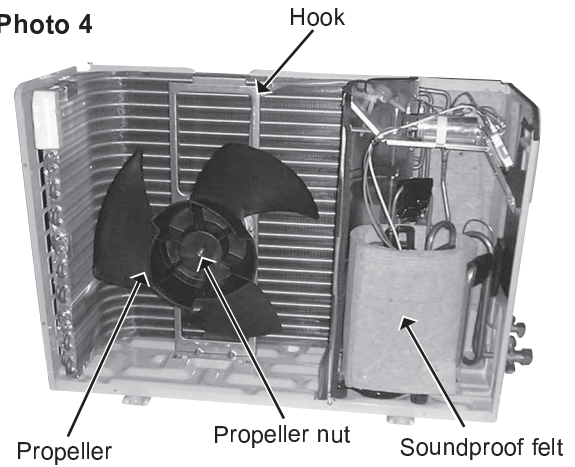

4. Removing the compressor

- (1) Remove the cabinet. (Refer to 1.)
- (2) Remove the relay panel.
- (3) Remove the soundproof felt.
- (4) Remove the terminal cover on the compressor.
- (5) Disconnect lead wires from the glass terminal of the compressor.
- (6) Recover gas from the refrigerant circuit.
- (7) Disconnect the welded part of the discharge pipe.
- (8) Disconnect the welded part of the suction pipe.
- (9) Remove nuts fixing the compressor.
- (10) Remove the compressor.

NOTE

- Before using a burner, reclaim gas from the pipes until the pressure gauge shows 0 kg/cm² (MPa).
- Use the burner under the condition that gas can be recovered even when the inner pressure rises by heat.

Photo 5

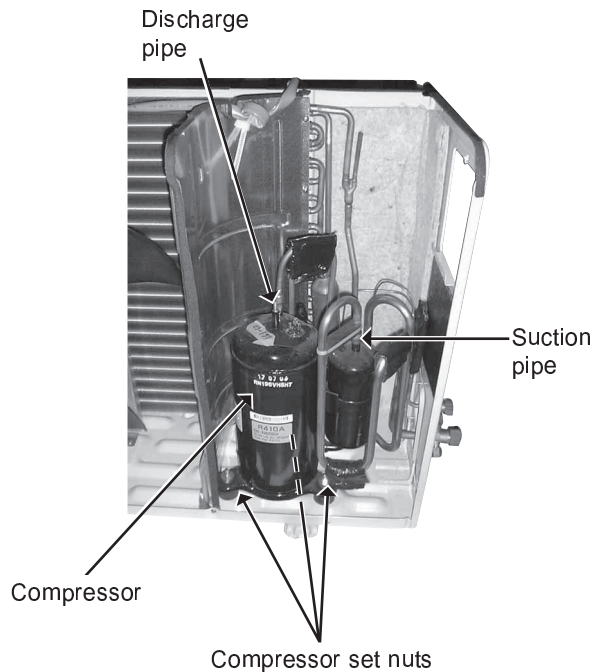

**10-2. MUCF-A24WV -[E1]
OUTDOOR UNIT**

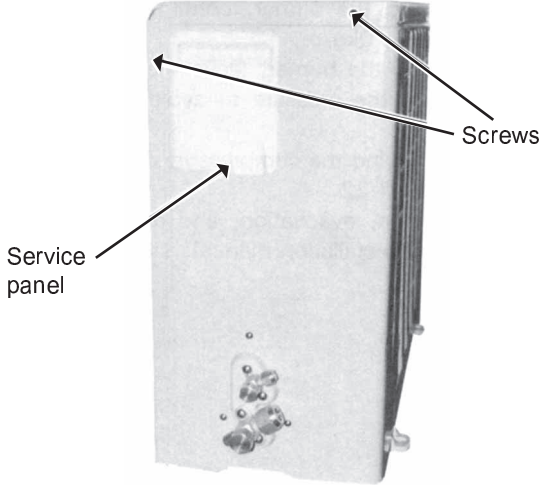
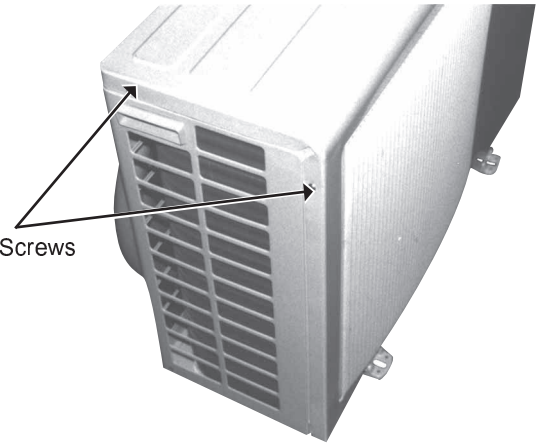
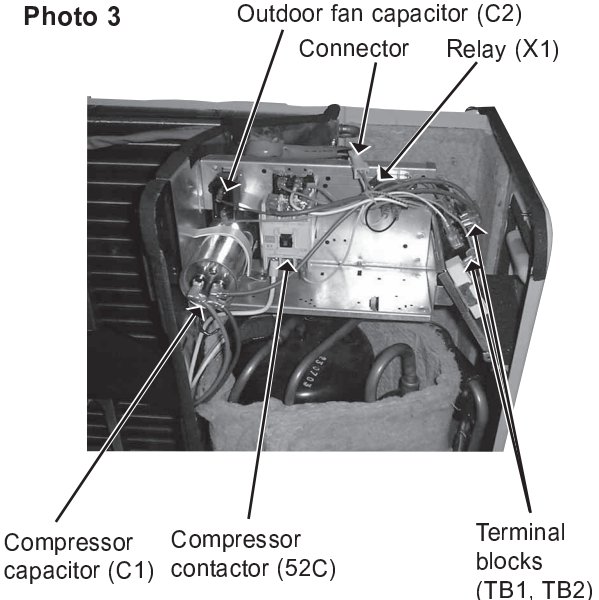
OPERATING PROCEDURE	PHOTOS
<p>1. Removing the cabinet</p> <p>(1) Remove the screws of the cabinet.</p> <p>(2) Hold the bottom of the cabinet on the both side to remove the cabinet.</p>	<p>Photo 1</p>  <p>Service panel</p> <p>Screws</p> <p>Photo 2</p>  <p>Screws</p>
<p>2. Removing the electrical parts</p> <p>(1) Remove the cabinet . (Refer to 1.)</p> <p>(2) Remove the following parts.</p> <ul style="list-style-type: none"> •Compressor capacitor (C1) •Outdoor fan capacitor (C2) •Terminal block(TB1, TB2) •Relay (X1) •Compressor contactor (52C) 	<p>Photo 3</p>  <p>Outdoor fan capacitor (C2)</p> <p>Connector</p> <p>Relay (X1)</p> <p>Compressor capacitor (C1)</p> <p>Compressor contactor (52C)</p> <p>Terminal blocks (TB1, TB2)</p>

OPERATING PROCEDURE

3. Removing the outdoor fan motor

- (1) Remove the cabinet. (Refer to 1.)
- (2) Disconnect the connector and remove the hooked lead wire from the fan motor.
- (3) Remove the propeller nut and remove the propeller.
- (4) Remove the screws fixing the fan motor.
- (5) Remove the outdoor fan motor.

4. Removing the compressor

- (1) Remove the cabinet. (Refer to 1.)
- (2) Remove the soundproof felt.
- (3) Remove the terminal cover on the compressor.
- (4) Disconnect the lead wires from the glass terminal of the compressor.
- (5) Recover gas from the refrigerant circuit.
- (6) Disconnect the welded part of the discharge pipe.
- (7) Disconnect the welded part of the suction pipe.
- (8) Remove nuts fixing the compressor.
- (9) Remove the compressor.

NOTE

- Before using a burner, reclaim gas from the pipes until the pressure gauge shows 0 kg/cm² (0MPa).
- Use the burner under the condition that gas can be recovered even when the inner pressure rises by heat.

PHOTOS

Photo 4

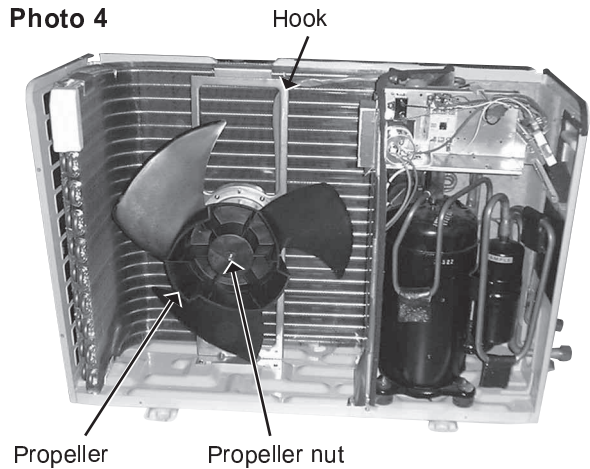
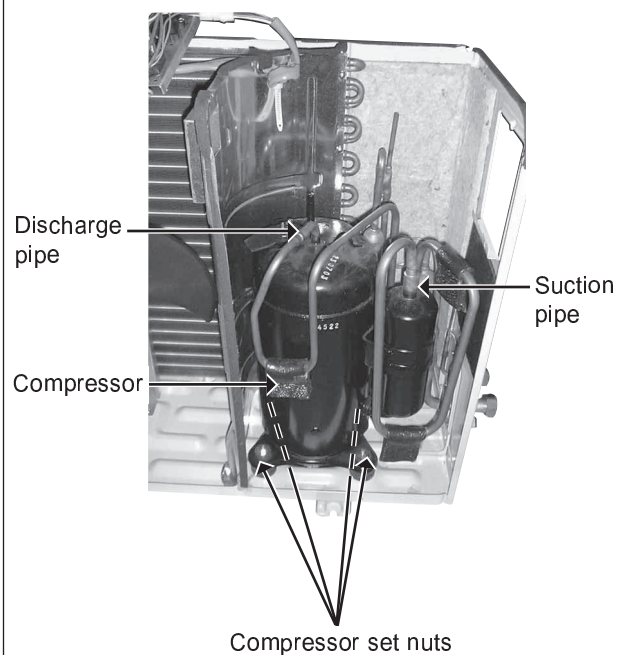

Photo 5



MUCF-A18WV -E1

MUCF-A24WV -E1

OUTDOOR UNIT

STRUCTURAL PARTS, ELECTRICAL PARTS AND FUNCTIONAL PARTS

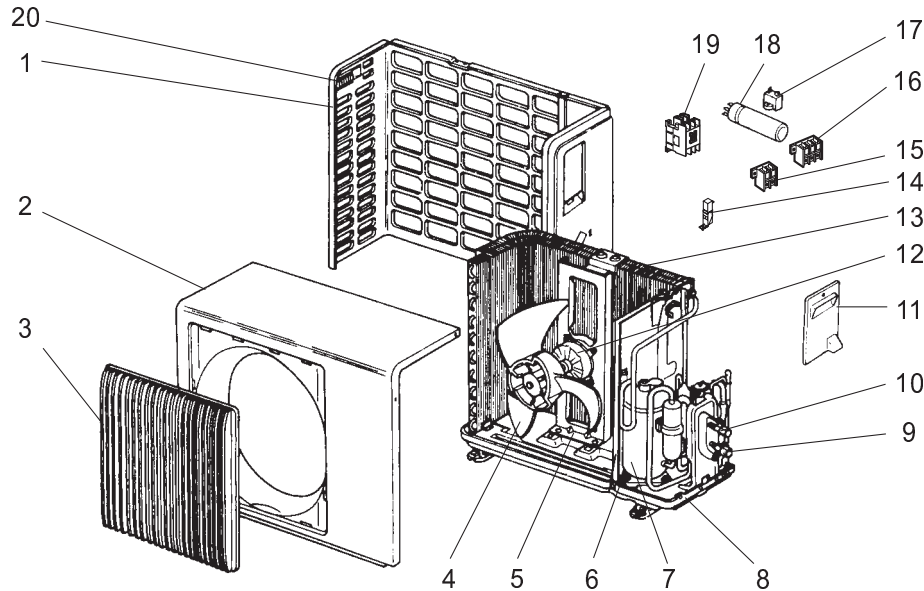

Part numbers that are circled are not shown in the illustration.

No.	Part No.	Part Name	Symbol in Wiring Diagram	Q'ty/unit		Remarks
				MUCF-A18WV- E1	MUCF-A24WV- E1	
1	E02 817 233	BACK PANEL(OUT)		1	1	
2	E02 817 232	CABINET		1	1	
3	E02 817 521	GRILLE(OUT)		1	1	
4	E02 141 501	PROPELLER		1	1	
5	E02 139 515	MOTOR SUPPORT		1	1	
6	E02 075 506	COMPRESSOR RUBBER SET		3		3RUBBERS/SET
	E02 527 506	COMPRESSOR RUBBER SET			4	4RUBBERS/SET
7	E02 817 900	COMPRESSOR	MC	1		RN196VHSHT
	E02 821 900	COMPRESSOR	MC		1	NN29VBAHT
8	E02 817 290	BASE		1		
	E02 818 290	BASE			1	
9	E02 817 661	STOP VALVE(GAS)		1		φ12.7
	E02 818 661	STOP VALVE(GAS)			1	φ15.88
10	E02 817 662	STOP VALVE(LIQUID)		1	1	φ 6.35
11	E02 817 245	SERVICE PANEL		1	1	
12	E02 144 301	OUTDOOR FAN MOTOR	MF	1		RA6V50 - □□
	E02 818 301	OUTDOOR FAN MOTOR	MF		1	RA6V60 - □□
13	E02 817 630	OUTDOOR HEAT EXCHANGER		1		
	E02 818 630	OUTDOOR HEAT EXCHANGER			1	
14	E02 466 383	SURGE ABSORBER	DSAR	1	1	
15	E02 818 374	TERMINAL BLOCK	TB2	1	1	2P
16	E02 817 374	TERMINAL BLOCK	TB1	1	1	3P
17	E02 138 351	OUTDOOR FAN CAPACITOR	C2	1	1	3.0μF/440V AC
18	E02 817 353	COMPRESSOR CAPACITOR	C1	1		40μF/440V AC
	E02 818 353	COMPRESSOR CAPACITOR	C1		1	55μF/440V AC
19	E07 012 340	COMPRESSOR CONTACTOR	52C		1	
20	E02 817 009	HANDLE		1	1	
21	E02 746 937	CAPILLARY TUBE		1		φ3.0×φ1.6×650
	E02 825 936	CAPILLARY TUBE			1	φ3.0×φ2.0×1000
	E02 820 936	CAPILLARY TUBE		1		φ2.5×φ0.6×1000
22	E02 466 340	COMPRESSOR CONTACTOR	52C	1		
23	E02 466 340	RELAY	X1		1	

