

Revision A:

 ●MXZ-A14WV -^{E1} has been added.

Please void OB319.

**No. OB319
REVISED EDITION-A**

SERVICE MANUAL

**Inverter-controlled multi system type
Models**
MXZ-A14WV -^{E1}
MXZ-A18WV -^{E1}
MXZ-A26WV -^{E1}
MXZ-A32WV -^{E1}

Indication of model name

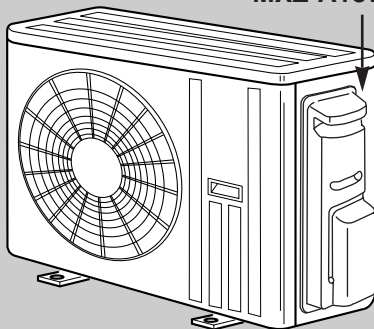
MXZ-A18WV -^{E1}

CONTENTS

1. TECHNICAL CHANGES	2
2. PART NAMES AND FUNCTIONS.....	6
3. INDOOR/OUTDOOR CORRESPONDENCE TABLE	6
4. INDOOR UNITS COMBINATION	9
5. SPECIFICATION.....	21
6. NOISE CRITERIA CURVES	23
7. OUTLINES AND DIMENSIONS	24
8. WIRING DIAGRAM	27
9. REFRIGERANT SYSTEM DIAGRAM	30
10. PERFORMANCE CURVES	33
11. MICROPROCESSOR CONTROL.....	47
12. TROUBLESHOOTING.....	52
13. DISASSEMBLY INSTRUCTIONS.....	71
14. PARTS LIST.....	78
15. OPTIONAL PARTS.....	83

NOTE:

•This service manual describes technical data of outdoor units.

As for indoor units, refer to the service manual OB307 REVISED EDITION-C, OB321, OB327, OB329, OB336 REVISED EDITION-A, OB345, OC302 or OC303.



MXZ-14WV -^[E1]

New model

MXZ-18TV -^[E2] → MXZ-A18WV -^[E1]

1. Outdoor model has been changed.
2. Refrigerant has been changed. (R22→R410A)

MXZ-24UV -^[E2] → MXZ-A26WV -^[E1]

1. Cooling capacity has been made larger. (7.1kW→7.2kW)
2. Combinations of connectable indoor units have been increased.
3. Capacity class of connectable indoor units have been made larger.
4. Compressor has been changed. (THV247FBA→TNB220FMCH)
5. Outdoor fan motor has been changed. (RA6V60-BA→PM8H60-UA)
6. Refrigerant has been changed. (R22→R410A)
7. Refrigerant system diagram has been changed.
 - 1 of 2 high pressure switch has been removed.
 - Accumulator has been removed.
 - Receiver has been added.

MXZ-32SV -^[E2] → MXZ-A32WV -^[E1]

1. Combinations of connectable indoor units have been increased.
2. Capacity class of connectable indoor units have been made larger.
3. Compressor has been changed. (THV247FBA→TNB220FMCH)
4. Outdoor fan motor has been changed. (RA6V60-BA→PM8H60-UA)
5. Refrigerant has been changed. (R22→R410A)
6. Refrigerant system diagram has been changed.
 - 1 of 2 high pressure switch has been removed.
 - Accumulator has been removed.
 - Receiver has been added.

INFORMATION FOR THE AIR CONDITIONER WITH R410A REFRIGERANT

- This room air conditioner adopts an HFC refrigerant (R410A) which never destroys the ozone layer.
 - Pay particular attention to the following points, though the basic installation procedure is same as that for R22 conditioners.
- ① As R410A has working pressure approximate 1.6 times as high as that of R22, some special tools and piping parts/materials are required. Refer to the table below.
 - ② Take sufficient care not to allow water and other contaminations to enter the R410A refrigerant during storage and installation, since it is more susceptible to contaminations than R22.
 - ③ For refrigerant piping, use clean, pressure-proof parts/materials specifically designed for R410A. (Refer to 2. Refrigerant piping.)
 - ④ Composition change may occur in R410A since it is a mixed refrigerant. When charging, charge liquid refrigerant to prevent composition change.

		New refrigerant	Previous refrigerant
Refrigerant	Refrigerant	R410A	R22
	Composition (Ratio)	HFC-32: HFC-125 (50%:50%)	R22 (100%)
	Refrigerant handling	Pseudo-azeotropic refrigerant	Single refrigerant
	Chlorine	Not included	Included
	Safety group (ASHRAE)	A1/A1	A1
	Molecular weight	72.6	86.5
	Boiling point (°C)	-51.4	-40.8
	Steam pressure [25°C](Mpa)	1.557	0.94
	Saturated steam density [25°C](Kg/m³)	64	44.4
	Combustibility	Non combustible	Non combustible
	ODP *1	0	0.055
	GWP *2	1730	1700
	Refrigerant charge method	From liquid phase in cylinder	Gas phase
	Additional charge on leakage	Possible	Possible
Refrigerating oil	Kind	Incompatible oil	Compatible oil
	Color	Non	Light yellow
	Smell	Non	Non

*1 :Ozone Destruction Parameter : based on CFC-11

*2 :Global Warmth Parameter : based on CO₂

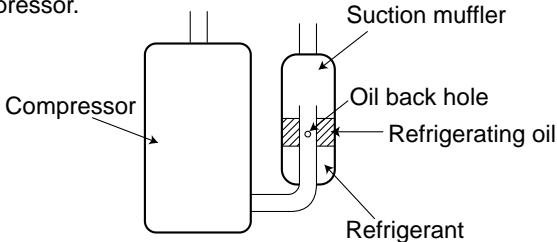
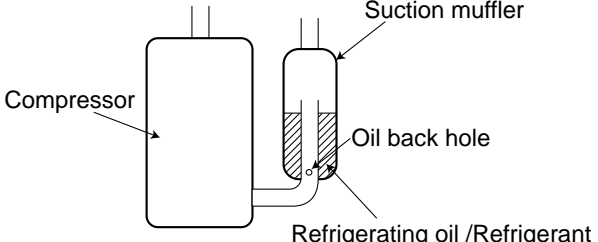
		New Specification	Current Specification
Compressor	<p>The incompatible refrigerating oil easily separates from refrigerant and is in the upper layer inside the suction muffler. Raising position of the oil back hole enables to back the refrigerating oil of the upper layer to flow back to the compressor.</p> 	<p>Since refrigerant and refrigerating oil are compatible each, refrigerating oil backs to the compressor through the lower position oil back hole.</p> 	

NOTE : The unit of pressure has been changed to MPa on the international system of units(SI unit system).
The conversion factor is: **1(MPa [Gauge]) =10.2(kgf/cm² [Gauge])**

Conversion chart of refrigerant temperature and pressure

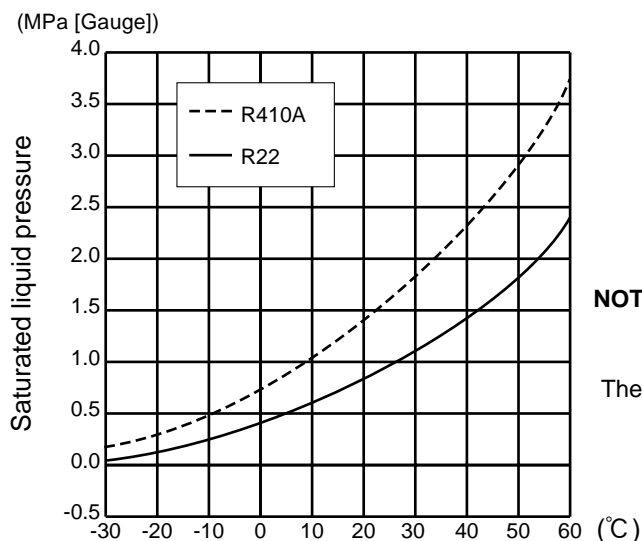

NOTE : The unit of pressure has been changed to MPa on the international system of units(SI unit system).

The conversion factor is: **1(MPa [Gauge]) =10.2(kgf/cm² [Gauge])**

1.Tools dedicated for the air conditioner with R410A refrigerant

The following tools are required for R410A refrigerant. Some R22 tools can be substituted for R410A tools.

The diameter of the service port on the stop valve in outdoor unit has been changed to prevent any other refrigerant being charged into the unit. Cap size has been changed from 7/16 UNF with 20 threads to 1/2 UNF with 20 threads.

R410A tools	Can R22 tools be used?	Description
Gauge manifold	No	R410A has high pressures beyond the measurement range of existing gauges. Port diameters have been changed to prevent any other refrigerant from being charged into the unit.
Charge hose	No	Hose material and cap size have been changed to improve the pressure resistance.
Gas leak detector	No	Dedicated for HFC refrigerant.
Torque wrench	Yes	6.35 mm and 9.52 mm
	No	12.7 mm and 15.88 mm
Flare tool	Yes	Clamp bar hole has been enlarged to reinforce the spring strength in the tool.
Flare gauge	New	Provided for flaring work (to be used with R22 flare tool).
Vacuum pump adapter	New	Provided to prevent the back flow of oil. This adapter enables you to use vacuum pumps.
Electronic scale for refrigerant charging	New	It is difficult to measure R410A with a charging cylinder because the refrigerant bubbles due to high pressure and high-speed vaporization

No : Not Substitutable for R410A Yes : Substitutable for R410A

2.Refrigerant piping

① Specifications

Use the refrigerant pipes that meet the following specifications.

Pipe	Outside diameter	Wall thickness	Insulation material
	mm		
For liquid	6.35/9.52	0.8 mm/0.8 mm	Heat resisting foam plastic Specific gravity 0.045 Thickness 8 mm
For gas	9.52	0.8 mm	
	12.7	0.8 mm	
	15.88	1.0 mm	

- Use a copper pipe or a copper-alloy seamless pipe with a thickness of 0.8 mm. Never use any pipe with a thickness less than 0.8mm, as the pressure resistance is insufficient.

② Flaring work and flare nut

Flaring work for R410A pipe differs from that for R22 pipe.

For details of flaring work, refer to Installation manual "FLARING WORK".

Pipe diameter	Dimension of flare nut	
	R410A	R22
mm		
6.35	17	17
9.52	22	22
12.7	26	24
15.88	29	27

3.Refrigerant oil

Apply the special refrigeration oil (accessories: packed with indoor unit) to the flare and the union seat surfaces.

4.Air purge

- Do not discharge the refrigerant into the atmosphere.
Take care not to discharge refrigerant into the atmosphere during installation, reinstallation, or repairs to the refrigerant circuit.
- Use the vacuum pump for air purging for the purpose of environmental protection.

5.Additional charge

For additional charging, charge the refrigerant from liquid phase of the gas cylinder.

If the refrigerant is charged from the gas phase, composition change may occur in the refrigerant inside the cylinder and the outdoor unit. In this case, ability of the refrigerating cycle decreases or normal operation can be impossible. However, charging the liquid refrigerant all at once may cause the compressor to be locked. Thus, charge the refrigerant slowly.

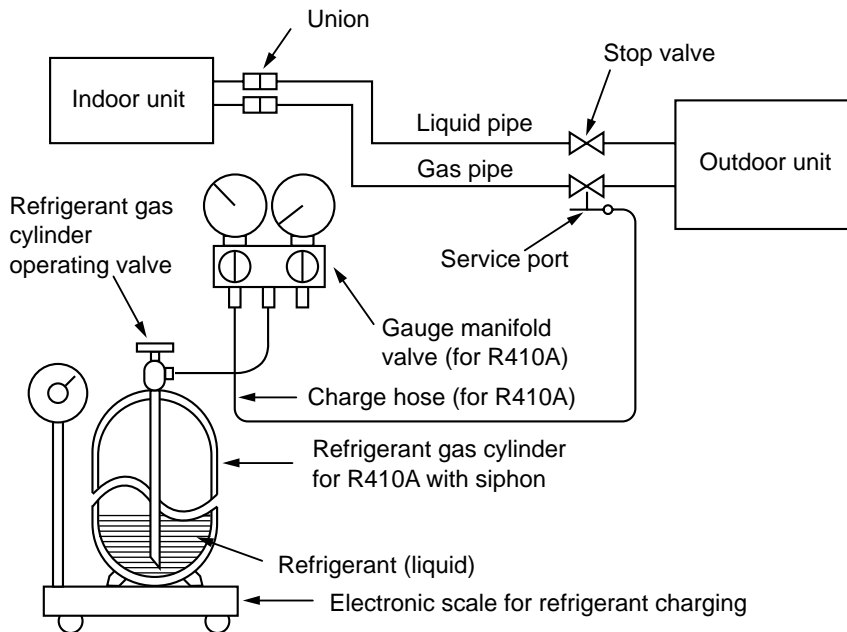

2

PART NAMES AND FUNCTIONS

OUTDOOR UNIT

MXZ-A14WV-^[E1]

MXZ-A18WV-^[E1]

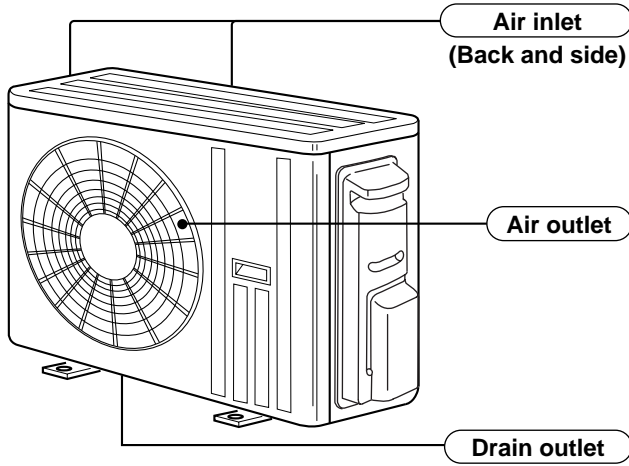

MXZ-A26WV-^[E1]

MXZ-A32WV-^[E1]

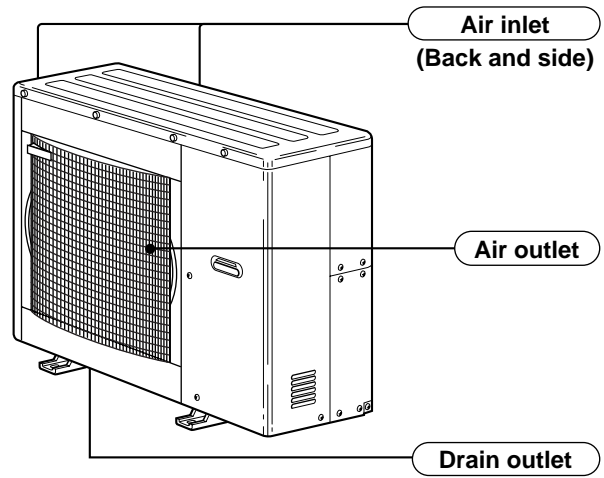

ACCESSORIES

MXZ-A14WV-^[E1]

MXZ-A18WV-^[E1]

MXZ-A26WV-^[E1]

MXZ-A32WV-^[E1]

①	Drain socket	1
②	Drain cap	2

3 INDOOR/ OUTDOOR CORRESPONDENCE TABLE

MXZ-A14WV -^[E1]

	OUTDOOR UNIT
	MXZ-A14WV- ^[E1]
Combination of the connectable indoor units	07+07
	07+09
	07+12
	09+09
	09+12

*There is no combination other than this table.

MXZ-A18WV -^[E1]

	OUTDOOR UNIT
	MXZ-A18WV- ^[E1]
Combination of the connectable indoor units	07+07
	07+09
	07+12
	09+09
	09+12
	12+12

*There is no combination other than this table.



MXZ-A26WV -^[E1]

	OUTDOOR UNIT
	MXZ-A26WV-^[E1]
Combination of the connectable indoor units	07+07
	07+09
	07+12
	07+18
	07+24
	07+26
	09+09
	09+12
	09+18
	09+24
	09+26
	12+12
	12+18
	12+24
	12+26
	18+18
	18+24
	18+26
	07+07+07
	07+07+09
	07+07+12
	07+07+18
	07+07+24
	07+07+26
	07+09+09
	07+09+12
	07+09+18
	07+09+24
	07+09+26
	07+12+12
	07+12+18
	07+12+24
	07+12+26
	07+18+18
	07+18+24
	07+18+26
	09+09+09
	09+09+12
	09+09+18
	09+09+24
	09+09+26
	09+12+12
	09+12+18
	09+12+24
	09+12+26
	09+18+18
	09+18+24
	12+12+12
12+12+18	
12+12+24	
12+12+26	
12+18+18	
12+18+24	

*There is no combination other than this table.

MXZ-A32WV -^[E1]

OUTDOOR UNIT	
MXZ-A32WV-^[E1]	
Combination of the connectable indoor units	07+07
	07+09
	07+12
	07+18
	07+24
	07+26
	09+09
	09+12
	09+18
	09+24
	09+26
	12+12
	12+18
	12+24
	12+26
	18+18
	18+24
	18+26
	24+24
	24+26
	07+07+07
	07+07+09
	07+07+12
	07+07+18
	07+07+24
	07+07+26
	07+09+09
	07+09+12
	07+09+18
	07+09+24
	07+09+26
	07+12+12
	07+12+18
	07+12+24
	07+12+26
	07+18+18
	07+18+24
	07+18+26
	09+09+09
	09+09+12
	09+09+18
	09+09+24
	09+09+26
	09+12+12
	09+12+18
	09+12+24
09+12+26	
09+18+18	

OUTDOOR UNIT	
MXZ-A32WV-^[E1]	
Combination of the connectable indoor units	09+18+24
	12+12+12
	12+12+18
	12+12+24
	12+12+26
	12+18+18
	12+18+24
	07+07+07+07
	07+07+07+09
	07+07+07+12
	07+07+07+18
	07+07+07+24
	07+07+07+26
	07+07+09+09
	07+07+09+12
	07+07+09+18
	07+07+09+24
	07+07+09+26
	07+07+12+12
	07+07+12+18
	07+07+12+24
	07+07+18+18
	07+09+09+09
	07+09+09+12
	07+09+09+18
	07+09+09+24
	07+09+12+12
	07+09+12+18
	07+09+12+24
	07+12+12+12
	07+12+12+18
	09+09+09+09
	09+09+09+12
	09+09+09+18
	09+09+09+24
	09+09+12+12
	09+09+12+18
	09+12+12+12
	12+12+12+12

*There is no combination other than this table.

4

INDOOR UNITS COMBINATION

MXZ-A14WV - E1

NOTE: Electrical data is for outdoor unit only.

Indoor units combination	Cooling capacity (kW)			Outdoor unit power consumption (kW)	Current (A)	Power factor (%)
	Unit A	Unit B	Total		230V	
07	2.3	–	2.3 (0.9-2.95)	0.750 (0.230-1.000)	3.62	90
09	2.5	–	2.5 (0.9-3.30)	0.810 (0.230-1.070)	3.91	90
12	3.4	–	3.4 (0.9-4.00)	1.180 (0.220-1.450)	5.70	90
07+07	1.90	1.90	3.8 (1.49-4.30)	1.100 (0.370-1.280)	5.31	90
07+09	1.87	2.03	3.9 (1.49-4.30)	1.120 (0.370-1.280)	5.41	90
07+12	1.57	2.33	3.9 (1.51-4.40)	1.130 (0.370-1.330)	5.46	90
09+09	1.95	1.95	3.9 (1.51-4.40)	1.130 (0.370-1.330)	5.46	90
09+12	1.69	2.31	4.0 (1.53-4.50)	1.150 (0.370-1.330)	5.55	90

NOTE: Electrical data is for outdoor unit only.

Indoor units combination	Heating capacity (kW)			Outdoor unit power consumption (kW)	Current (A)	Power factor (%)
	Unit A	Unit B	Total		230V	
07	3.3	–	3.3 (0.9-4.0)	0.980 (0.230-1.120)	4.73	90
09	3.6	–	3.6 (0.9-4.5)	1.070 (0.230-1.200)	5.17	90
12	4.0	–	4.0 (0.9-4.8)	1.400 (0.220-1.680)	6.76	90
07+07	2.20	2.20	4.4 (1.53-4.8)	1.080 (0.300-1.180)	5.22	90
07+09	2.11	2.29	4.4 (1.53-4.8)	1.070 (0.300-1.180)	5.17	90
07+12	1.78	2.62	4.4 (1.55-4.9)	1.070 (0.300-1.180)	5.17	90
09+09	2.20	2.20	4.4 (1.55-4.9)	1.060 (0.300-1.180)	5.12	90
09+12	1.91	2.59	4.5 (1.56-5.0)	1.060 (0.300-1.190)	5.12	90

MXZ-A18WV - E1

NOTE: Electrical data is for outdoor unit only.

Indoor units combination	Cooling capacity (kW)			Outdoor unit power consumption (kW)	Current (A)	Power factor (%)
	Unit A	Unit B	Total		230V	
07	2.3	–	2.3 (0.9-2.95)	0.750 (0.225-1.000)	3.62	90
09	2.5	–	2.5 (0.9-3.30)	0.810 (0.225-1.070)	3.91	90
12	3.4	–	3.4 (0.9-4.00)	1.180 (0.220-1.450)	5.70	90
07+07	2.3	2.3	4.6 (1.49-5.30)	1.480 (0.370-2.060)	7.15	90
07+09	2.3	2.5	4.8 (1.49-5.40)	1.600 (0.370-2.070)	7.73	90
07+12	2.02	2.98	5.0 (1.51-5.60)	1.610 (0.365-2.100)	7.78	90
09+09	2.5	2.5	5.0 (1.51-5.55)	1.780 (0.370-2.105)	8.60	90
09+12	2.2	3.1	5.3 (1.53-5.80)	1.830 (0.365-2.110)	8.84	90
12+12	2.65	2.65	5.4 (1.55-6.00)	1.860 (0.370-2.130)	8.99	90

NOTE: Electrical data is for outdoor unit only.

Indoor units combination	Heating capacity (kW)			Outdoor unit power consumption (kW)	Current (A)	Power factor (%)
	Unit A	Unit B	Total		230V	
07	3.3	–	3.3 (0.9-4.0)	0.980 (0.225-1.115)	4.73	90
09	3.6	–	3.6 (0.9-4.5)	1.065 (0.225-1.195)	5.14	90
12	4.0	–	4.0 (0.9-4.8)	1.400 (0.220-1.680)	6.76	90
07+07	3.05	3.05	6.1 (1.53-6.70)	1.930 (0.300-2.070)	9.32	90
07+09	2.97	3.23	6.2 (1.53-6.80)	1.940 (0.300-2.040)	9.37	90
07+12	2.62	3.88	6.5 (1.55-7.00)	1.870 (0.295-1.980)	9.03	90
09+09	3.25	3.25	6.5 (1.55-7.0)	1.920 (0.295-2.010)	9.28	90
09+12	2.78	3.77	6.55 (1.56-7.1)	1.845 (0.295-1.950)	8.91	90
12+12	3.30	3.30	6.6 (1.58-7.2)	1.770 (0.290-1.850)	8.55	90

MXZ-A26WV - E1

NOTE: Electrical data is for outdoor unit only.

Indoor units combination	Cooling capacity (kW)				Outdoor unit power consumption (kW)	Current (A)	Power factor (%)
	Unit A	Unit B	Unit C	Total			
07	2.3	—	—	2.3 (1.4-3.0)	0.710 (0.400-0.920)	3.12	99
09	2.5	—	—	2.5 (1.4-3.3)	0.760 (0.400-1.010)	3.34	99
12	3.4	—	—	3.4 (1.5-4.3)	1.000 (0.400-1.290)	4.39	99
18	5.0	—	—	5.0 (1.6-5.6)	1.440 (0.420-1.630)	6.32	99
24	6.0	—	—	6.0 (1.6-6.6)	1.930 (0.400-2.130)	8.48	99
26	7.1	—	—	7.1 (1.7-7.4)	2.580 (0.410-2.710)	11.33	99
07+07	2.3	2.3	—	4.6 (2.0-5.4)	1.180 (0.600-1.600)	5.18	99
07+09	2.1	2.7	—	4.8 (2.0-5.8)	1.300 (0.600-1.770)	5.71	99
07+12	2.1	3.6	—	5.7 (2.0-6.6)	1.710 (0.600-2.200)	7.51	99
07+18	2.01	5.18	—	7.2 (2.0-7.7)	2.400 (0.560-2.710)	10.54	99
07+24	1.62	5.57	—	7.2 (2.0-8.0)	2.360 (0.560-3.050)	10.36	99
07+26	1.52	5.67	—	7.2 (2.0-8.2)	2.360 (0.560-3.200)	10.36	99
09+09	2.5	2.5	—	5.0 (2.0-6.2)	1.360 (0.580-1.950)	5.97	99
09+12	2.52	3.37	—	5.9 (2.0-7.3)	1.860 (0.580-2.670)	8.17	99
09+18	2.4	4.8	—	7.2 (2.0-8.5)	2.400 (0.560-3.200)	10.54	99
09+24	1.96	5.23	—	7.2 (2.0-8.5)	2.360 (0.560-3.170)	10.36	99
09+26	1.85	5.34	—	7.2 (2.0-8.5)	2.360 (0.560-3.170)	10.36	99
12+12	3.4	3.4	—	6.8 (2.0-8.5)	2.330 (0.580-3.260)	10.23	99
12+18	2.88	4.32	—	7.2 (2.0-8.5)	2.390 (0.560-3.210)	10.50	99
12+24	2.4	4.8	—	7.2 (2.0-8.5)	2.350 (0.560-3.180)	10.32	99
12+26	2.27	4.92	—	7.2 (2.0-8.5)	2.350 (0.560-3.180)	10.32	99
18+18	3.6	3.6	—	7.2 (2.1-8.5)	2.340 (0.590-3.160)	10.28	99
18+24	3.08	4.11	—	7.2 (2.1-8.5)	2.300 (0.570-3.110)	10.10	99
18+26	2.94	4.25	—	7.2 (2.1-8.5)	2.300 (0.570-3.110)	10.10	99
07+07+07	2.3	2.3	2.3	6.9 (2.9-8.1)	1.940 (0.690-2.410)	8.52	99
07+07+09	2.16	2.16	2.77	7.1 (2.9-8.5)	2.030 (0.690-2.510)	8.92	99
07+07+12	1.93	1.93	3.32	7.2 (2.9-8.5)	2.310 (0.690-2.620)	10.14	99
07+07+18	1.58	1.58	4.05	7.2 (2.9-8.5)	2.320 (0.700-2.570)	10.19	99
07+07+24	1.32	1.32	4.55	7.2 (2.9-8.5)	2.370 (0.680-2.530)	10.41	99
07+07+26	1.26	1.26	4.68	7.2 (2.9-8.5)	2.390 (0.680-2.530)	10.50	99
07+09+09	2.01	2.59	2.59	7.2 (2.9-8.5)	2.130 (0.690-2.620)	9.35	99
07+09+12	1.8	2.31	3.09	7.2 (2.9-8.5)	2.350 (0.690-2.620)	10.32	99
07+09+18	1.48	1.9	3.81	7.2 (2.9-8.5)	2.370 (0.700-2.570)	10.41	99
07+09+24	1.26	1.62	4.32	7.2 (2.9-8.5)	2.390 (0.680-2.530)	10.50	99

NOTE: Electrical data is for outdoor unit only.

Indoor units combination	Cooling capacity (kW)				Outdoor unit power consumption (kW)	Current (A)	Power factor (%)
	Unit A	Unit B	Unit C	Total			
07+09+26	1.2	1.54	4.45	7.2 (2.9-8.5)	2.390 (0.680-2.530)	10.50	99
07+12+12	1.62	2.79	2.79	7.2 (2.9-8.5)	2.350 (0.690-2.570)	10.32	99
07+12+18	1.36	2.33	3.5	7.2 (2.9-8.5)	2.320 (0.700-2.540)	10.19	99
07+12+24	1.17	2.0	4.01	7.2 (2.9-8.5)	2.350 (0.680-2.520)	10.32	99
07+12+26	1.12	1.92	4.16	7.2 (2.9-8.5)	2.350 (0.680-2.520)	10.32	99
07+18+18	1.17	3.01	3.01	7.2 (2.9-8.5)	2.330 (0.680-2.520)	10.23	99
07+18+24	1.02	2.64	3.52	7.2 (2.9-8.5)	2.300 (0.660-2.490)	10.10	99
07+18+26	0.98	2.54	3.67	7.2 (2.9-8.5)	2.300 (0.660-2.490)	10.10	99
09+09+09	2.36	2.36	2.36	7.1 (2.9-8.5)	2.030 (0.690-2.650)	8.92	99
09+09+12	2.16	2.16	2.89	7.2 (2.9-8.5)	2.350 (0.690-2.620)	10.32	99
09+09+18	1.8	1.8	3.6	7.2 (2.9-8.5)	2.370 (0.700-2.570)	10.41	99
09+09+24	1.54	1.54	4.11	7.2 (2.9-8.5)	2.390 (0.680-2.530)	10.50	99
09+09+26	1.47	1.47	4.25	7.2 (2.9-8.5)	2.390 (0.680-2.530)	10.50	99
09+12+12	1.97	2.61	2.61	7.2 (2.9-8.5)	2.350 (0.690-2.570)	10.32	99
09+12+18	1.66	2.21	3.32	7.2 (2.9-8.5)	2.380 (0.700-2.540)	10.45	99
09+12+24	1.44	1.92	3.84	7.2 (2.9-8.5)	2.350 (0.680-2.520)	10.32	99
09+12+26	1.37	1.83	3.98	7.2 (2.9-8.5)	2.350 (0.680-2.520)	10.32	99
09+18+18	1.44	2.88	2.88	7.2 (2.9-8.5)	2.330 (0.660-2.500)	10.23	99
09+18+24	1.27	2.54	3.38	7.2 (2.9-8.5)	2.300 (0.660-2.500)	10.10	99
12+12+12	2.4	2.4	2.4	7.2 (2.9-8.5)	2.090 (0.720-2.560)	9.18	99
12+12+18	2.05	2.05	3.08	7.2 (2.9-8.5)	2.280 (0.700-2.530)	10.01	99
12+12+24	1.8	1.8	3.6	7.2 (2.9-8.5)	2.260 (0.680-2.500)	9.93	99
12+12+26	1.72	1.72	3.74	7.2 (2.9-8.5)	2.260 (0.680-2.500)	9.93	99
12+18+18	1.8	2.7	2.7	7.2 (2.9-8.5)	2.240 (0.680-2.500)	9.84	99
12+18+24	1.6	2.4	3.2	7.2 (2.9-8.5)	2.220 (0.660-2.470)	9.75	99

NOTE: Electrical data is for outdoor unit only.

Indoor units combination	Heating capacity (kW)				Outdoor unit power consumption (kW)	Current (A)	Power factor (%)
	Unit A	Unit B	Unit C	Total			
07	3.3	–	–	3.3 (1.2-4.2)	1.050 (0.340-1.380)	4.61	99
09	3.6	–	–	3.6 (1.2-4.5)	1.110 (0.340-1.510)	4.87	99
12	4.0	–	–	4.0 (1.2-4.8)	1.210 (0.330-1.570)	5.31	99
18	7.2	–	–	7.2 (1.4-8.2)	2.270 (0.330-2.710)	9.97	99
24	7.9	–	–	7.9 (1.4-8.6)	2.700 (0.330-3.060)	11.86	99
26	8.6	–	–	8.6 (1.6-9.2)	3.220 (0.360-3.520)	14.14	99
07+07	3.3	3.3	–	6.6 (1.8-7.2)	2.020 (0.480-2.760)	8.87	99
07+09	3.02	3.88	–	6.9 (1.8-8.7)	2.120 (0.480-3.000)	9.31	99
07+12	2.69	4.61	–	7.3 (1.8-9.2)	2.130 (0.480-3.110)	9.35	99
07+18	2.49	6.41	–	8.9 (1.8-9.9)	2.470 (0.460-3.140)	10.85	99
07+24	2.03	6.97	–	9.0 (1.8-9.9)	2.520 (0.460-3.140)	11.07	99
07+26	1.91	7.09	–	9.0 (1.8-9.9)	2.520 (0.460-3.140)	11.07	99
09+09	3.6	3.6	–	7.2 (1.8-9.1)	2.170 (0.480-3.140)	9.53	99
09+12	3.26	4.34	–	7.6 (1.8-9.5)	2.210 (0.480-3.230)	9.71	99
09+18	3.0	6.0	–	9.0 (1.8-10.1)	2.520 (0.460-3.260)	11.07	99
09+24	2.45	6.55	–	9.0 (1.8-10.1)	2.500 (0.460-3.260)	10.98	99
09+26	2.31	6.69	–	9.0 (1.8-10.1)	2.500 (0.460-3.260)	10.98	99
12+12	4.0	4.0	–	8.0 (1.8-9.8)	2.370 (0.480-3.230)	10.41	99
12+18	3.6	5.4	–	9.0 (1.8-10.5)	2.500 (0.460-3.420)	10.98	99
12+24	3.0	6.0	–	9.0 (1.8-10.5)	2.480 (0.460-3.420)	10.89	99
12+26	2.84	6.16	–	9.0 (1.8-10.5)	2.480 (0.460-3.420)	10.89	99
18+18	4.5	4.5	–	9.0 (1.9-11.0)	2.210 (0.440-3.260)	9.71	99
18+24	3.86	5.14	–	9.0 (1.9-11.0)	2.210 (0.440-3.260)	9.71	99
18+26	3.68	5.32	–	9.0 (1.9-11.0)	2.210 (0.440-3.260)	9.71	99
07+07+07	2.9	2.9	2.9	8.7 (2.6-10.6)	2.150 (0.530-3.150)	9.44	99
07+07+09	2.67	2.67	3.44	8.8 (2.6-11.0)	2.170 (0.530-3.170)	9.53	99
07+07+12	2.42	2.42	4.15	9.0 (2.6-11.0)	2.200 (0.530-3.190)	9.66	99
07+07+18	1.96	1.96	5.06	9.0 (2.6-11.0)	2.040 (0.510-3.040)	8.96	99
07+07+24	1.65	1.65	5.68	9.0 (2.6-11.0)	2.040 (0.510-3.040)	8.96	99
07+07+26	1.57	1.57	5.85	9.0 (2.6-11.0)	2.040 (0.510-3.040)	8.96	99
07+09+09	2.52	3.24	3.24	9.0 (2.6-11.0)	2.200 (0.530-3.260)	9.66	99
07+09+12	2.25	2.89	3.85	9.0 (2.6-11.0)	2.180 (0.530-3.180)	9.57	99
07+09+18	1.85	2.38	4.76	9.0 (2.6-11.0)	2.020 (0.510-3.040)	8.87	99
07+09+24	1.57	2.02	5.4	9.0 (2.6-11.0)	2.020 (0.510-3.040)	8.87	99

NOTE: Electrical data is for outdoor unit only.

Indoor units combination	Heating capacity (kW)				Outdoor unit power consumption (kW)	Current (A)	Power factor (%)
	Unit A	Unit B	Unit C	Total			
07+09+26	1.5	1.92	5.57	9.0 (2.6-11.0)	2.020 (0.510-3.040)	8.87	99
07+12+12	2.03	3.48	3.48	9.0 (2.6-11.0)	2.180 (0.530-3.150)	9.57	99
07+12+18	1.7	2.91	4.37	9.0 (2.7-11.0)	1.940 (0.510-2.950)	8.52	99
07+12+24	1.46	2.51	5.02	9.0 (2.7-11.0)	1.940 (0.510-2.950)	8.52	99
07+12+26	1.4	2.4	5.2	9.0 (2.7-11.0)	1.940 (0.510-2.950)	8.52	99
07+18+18	1.46	3.76	3.76	9.0 (2.7-11.0)	1.850 (0.490-2.830)	8.12	99
07+18+24	1.28	3.3	4.4	9.0 (2.7-11.0)	1.850 (0.490-2.830)	8.12	99
07+18+26	1.23	3.17	4.58	9.0 (2.7-11.0)	1.850 (0.490-2.830)	8.12	99
09+09+09	3.0	3.0	3.0	9.0 (2.6-11.0)	2.170 (0.530-3.230)	9.53	99
09+09+12	2.7	2.7	3.6	9.0 (2.6-11.0)	2.160 (0.530-3.180)	9.49	99
09+09+18	2.25	2.25	4.5	9.0 (2.6-11.0)	2.000 (0.510-3.030)	8.78	99
09+09+24	1.92	1.92	5.14	9.0 (2.6-11.0)	2.000 (0.510-3.030)	8.78	99
09+09+26	1.84	1.84	5.31	9.0 (2.6-11.0)	2.000 (0.510-3.030)	8.78	99
09+12+12	2.45	3.27	3.27	9.0 (2.6-11.0)	2.160 (0.530-3.150)	9.49	99
09+12+18	2.07	2.76	4.15	9.0 (2.7-11.0)	1.920 (0.510-2.950)	8.43	99
09+12+24	1.8	2.4	4.8	9.0 (2.7-11.0)	1.920 (0.510-2.950)	8.43	99
09+12+26	1.72	2.29	4.97	9.0 (2.7-11.0)	1.920 (0.510-2.950)	8.43	99
09+18+18	1.8	3.6	3.6	9.0 (2.7-11.0)	1.830 (0.490-2.830)	8.04	99
09+18+24	1.58	3.17	4.23	9.0 (2.7-11.0)	1.830 (0.490-2.830)	8.04	99
12+12+12	3.0	3.0	3.0	9.0 (2.6-11.0)	2.150 (0.530-3.050)	9.44	99
12+12+18	2.57	2.57	3.85	9.0 (2.7-11.0)	1.890 (0.510-2.890)	8.30	99
12+12+24	2.25	2.25	4.5	9.0 (2.7-11.0)	1.890 (0.510-2.890)	8.30	99
12+12+26	2.16	2.16	4.68	9.0 (2.7-11.0)	1.890 (0.510-2.890)	8.30	99
12+18+18	2.25	3.37	3.37	9.0 (2.7-11.0)	1.800 (0.490-2.770)	7.91	99
12+18+24	2.0	3.0	4.0	9.0 (2.7-11.0)	1.800 (0.490-2.770)	7.91	99

MXZ-A32WV - E1

NOTE: Electrical data is for outdoor unit only.

Indoor units combination	Cooling capacity (kW)					Outdoor unit power consumption (kW)	Current (A)	Power factor (%)
	Unit A	Unit B	Unit C	Unit D	Total			
07	2.3	-	-	-	2.3 (1.4-3.0)	0.710 (0.400-0.920)	3.12	99
09	2.5	-	-	-	2.5 (1.4-3.3)	0.760 (0.400-1.010)	3.34	99
12	3.4	-	-	-	3.4 (1.5-4.3)	1.000 (0.400-1.290)	4.39	99
18	5.0	-	-	-	5.0 (1.6-5.6)	1.440 (0.420-1.630)	6.32	99
24	6.0	-	-	-	6.0 (1.6-6.6)	1.930 (0.400-2.130)	8.48	99
26	7.1	-	-	-	7.1 (1.7-7.4)	2.580 (0.410-2.710)	11.33	99
07+07	2.3	2.3	-	-	4.6 (2.0-5.4)	1.180 (0.600-1.600)	5.18	99
07+09	2.1	2.7	-	-	4.8 (2.0-5.8)	1.300 (0.600-1.770)	5.71	99
07+12	2.1	3.6	-	-	5.7 (2.0-6.6)	1.710 (0.600-2.200)	7.51	99
07+18	2.04	5.25	-	-	7.3 (2.0-7.7)	2.480 (0.560-2.710)	10.89	99
07+24	1.75	6.0	-	-	7.75 (2.0-8.0)	2.750 (0.560-3.050)	12.08	99
07+26	1.66	6.19	-	-	7.85 (2.0-8.2)	2.810 (0.560-3.200)	12.34	99
09+09	2.5	2.5	-	-	5.0 (2.0-6.2)	1.360 (0.580-1.950)	5.97	99
09+12	2.52	3.37	-	-	5.9 (2.0-7.3)	1.860 (0.580-2.670)	8.17	99
09+18	2.5	5.0	-	-	7.5 (2.0-8.5)	2.580 (0.560-3.200)	11.33	99
09+24	2.11	5.64	-	-	7.75 (2.0-8.6)	2.750 (0.560-3.280)	12.08	99
09+26	2.01	5.84	-	-	7.85 (2.0-8.7)	2.810 (0.560-3.320)	12.34	99
12+12	3.4	3.4	-	-	6.8 (2.0-8.8)	2.330 (0.580-3.270)	10.23	99
12+18	3.1	4.65	-	-	7.75 (2.0-8.8)	2.760 (0.560-3.220)	12.12	99
12+24	2.61	5.24	-	-	7.85 (2.0-8.8)	2.730 (0.560-3.180)	11.99	99
12+26	2.51	5.44	-	-	7.95 (2.0-8.8)	2.780 (0.560-3.180)	12.21	99
18+18	3.95	3.95	-	-	7.9 (2.1-8.8)	2.780 (0.590-3.160)	12.21	99
18+24	3.42	4.57	-	-	8.0 (2.1-8.8)	2.800 (0.570-3.120)	12.30	99
18+26	3.27	4.72	-	-	8.0 (2.1-8.8)	2.800 (0.570-3.120)	12.30	99
24+24	4.0	4.0	-	-	8.0 (2.1-8.8)	2.690 (0.550-3.080)	11.81	99
24+26	3.84	4.16	-	-	8.0 (2.1-8.8)	2.690 (0.550-3.080)	11.81	99
07+07+07	2.3	2.3	2.3	-	6.9 (2.9-8.1)	1.940 (0.690-2.410)	8.52	99
07+07+09	2.16	2.16	2.77	-	7.1 (2.9-8.6)	2.030 (0.690-2.720)	8.92	99
07+07+12	2.07	2.07	3.55	-	7.7 (2.9-9.0)	2.310 (0.690-2.970)	10.14	99
07+07+18	1.72	1.72	4.41	-	7.85 (2.9-9.0)	2.320 (0.700-2.920)	10.19	99
07+07+24	1.46	1.46	5.03	-	7.95 (2.9-9.0)	2.370 (0.680-2.880)	10.41	99
07+07+26	1.4	1.4	5.2	-	8.0 (2.9-9.0)	2.390 (0.680-2.880)	10.50	99
07+09+09	2.04	2.62	2.62	-	7.3 (2.9-8.9)	2.130 (0.690-2.940)	9.35	99
07+09+12	1.93	2.49	3.33	-	7.75 (2.9-9.0)	2.350 (0.690-2.970)	10.32	99

NOTE: Electrical data is for outdoor unit only.

Indoor units combination	Cooling capacity (kW)					Outdoor unit power consumption (kW)	Current (A)	Power factor (%)
	Unit A	Unit B	Unit C	Unit D	Total			
07+09+18	1.62	2.09	4.18	–	7.9 (2.9-9.0)	2.370 (0.700-2.920)	10.41	99
07+09+24	1.4	1.8	4.8	–	8.0 (2.9-9.0)	2.390 (0.680-2.880)	10.50	99
07+09+26	1.33	1.71	4.95	–	8.0 (2.9-9.0)	2.390 (0.680-2.880)	10.50	99
07+12+12	1.77	3.04	3.04	–	7.85 (2.9-9.0)	2.350 (0.690-2.920)	10.32	99
07+12+18	1.49	2.56	3.84	–	7.9 (2.9-9.0)	2.320 (0.700-2.890)	10.19	99
07+12+24	1.3	2.23	4.46	–	8.0 (2.9-9.0)	2.350 (0.680-2.860)	10.32	99
07+12+26	1.24	2.13	4.62	–	8.0 (2.9-9.0)	2.350 (0.680-2.860)	10.32	99
07+18+18	1.3	3.34	3.34	–	8.0 (2.9-9.0)	2.330 (0.680-2.860)	10.23	99
07+18+24	1.14	2.93	3.91	–	8.0 (2.9-9.0)	2.300 (0.660-2.830)	10.10	99
07+18+26	1.09	2.82	4.07	–	8.0 (2.9-9.0)	2.300 (0.660-2.830)	10.10	99
09+09+09	2.36	2.36	2.36	–	7.1 (2.9-9.0)	2.030 (0.690-3.010)	8.92	99
09+09+12	2.32	2.32	3.11	–	7.75 (2.9-9.0)	2.350 (0.690-2.970)	10.32	99
09+09+18	1.97	1.97	3.95	–	7.9 (2.9-9.0)	2.370 (0.700-2.920)	10.41	99
09+09+24	1.71	1.71	4.57	–	8.0 (2.9-9.0)	2.390 (0.680-2.880)	10.50	99
09+09+26	1.63	1.63	4.72	–	8.0 (2.9-9.0)	2.390 (0.680-2.880)	10.50	99
09+12+12	2.15	2.85	2.85	–	7.85 (2.9-9.0)	2.350 (0.690-2.920)	10.32	99
09+12+18	1.84	2.46	3.69	–	8.0 (2.9-9.0)	2.380 (0.700-2.890)	10.45	99
09+12+24	1.6	2.13	4.26	–	8.0 (2.9-9.0)	2.350 (0.680-2.860)	10.32	99
09+12+26	1.53	2.04	4.42	–	8.0 (2.9-9.0)	2.350 (0.680-2.860)	10.32	99
09+18+18	1.6	3.2	3.2	–	8.0 (2.9-9.0)	2.330 (0.660-2.840)	10.23	99
09+18+24	1.41	2.82	3.76	–	8.0 (2.9-9.0)	2.300 (0.660-2.830)	10.10	99
12+12+12	2.65	2.65	2.65	–	7.95 (2.9-9.0)	2.280 (0.720-2.910)	10.01	99
12+12+18	2.28	2.28	3.42	–	8.0 (2.9-9.0)	2.280 (0.700-2.870)	10.01	99
12+12+24	2.0	2.0	4.0	–	8.0 (2.9-9.0)	2.260 (0.680-2.840)	9.93	99
12+12+26	1.92	1.92	4.16	–	8.0 (2.9-9.0)	2.260 (0.680-2.840)	9.93	99
12+18+18	2.0	3.0	3.0	–	8.0 (2.9-9.0)	2.240 (0.680-2.840)	9.84	99
12+18+24	1.77	2.66	3.55	–	8.0 (2.9-9.0)	2.220 (0.660-2.810)	9.75	99
07+07+07+07	1.95	1.95	1.95	1.95	7.8 (3.7-9.2)	2.180 (0.810-2.670)	9.57	99
07+07+07+09	1.83	1.83	1.83	2.36	7.85 (3.7-9.2)	2.190 (0.810-2.670)	9.62	99
07+07+07+12	1.68	1.68	1.68	2.91	7.95 (3.7-9.2)	2.210 (0.810-2.650)	9.71	99
07+07+07+18	1.43	1.43	1.43	3.69	8.0 (3.7-9.2)	2.150 (0.790-2.620)	9.44	99
07+07+07+24	1.24	1.24	1.24	4.26	8.0 (3.7-9.2)	2.130 (0.770-2.590)	9.35	99
07+07+07+26	1.19	1.19	1.19	4.42	8.0 (3.7-9.2)	2.130 (0.770-2.590)	9.35	99
07+07+09+09	1.72	1.72	2.2	2.2	7.85 (3.7-9.2)	2.190 (0.810-2.670)	9.62	99

NOTE: Electrical data is for outdoor unit only.

Indoor units combination	Cooling capacity (kW)					Outdoor unit power consumption (kW)	Current (A)	Power factor (%)
	Unit A	Unit B	Unit C	Unit D	Total			
07+07+09+12	1.59	1.59	2.04	2.72	7.95 (3.7-9.2)	2.210 (0.810-2.650)	9.71	99
07+07+09+18	1.36	1.36	1.75	3.51	8.0 (3.7-9.2)	2.150 (0.790-2.620)	9.44	99
07+07+09+24	1.19	1.19	1.53	4.08	8.0 (3.7-9.2)	2.130 (0.770-2.590)	9.35	99
07+07+09+26	1.14	1.14	1.46	4.24	8.0 (3.7-9.2)	2.130 (0.770-2.590)	9.35	99
07+07+12+12	1.47	1.47	2.52	2.52	8.0 (3.7-9.2)	2.210 (0.810-2.620)	9.71	99
07+07+12+18	1.27	1.27	2.18	3.27	8.0 (3.7-9.2)	2.120 (0.790-2.590)	9.31	99
07+07+12+24	1.12	1.12	1.92	3.84	8.0 (3.7-9.2)	2.100 (0.770-2.560)	9.22	99
07+07+18+18	1.12	1.12	2.88	2.88	8.0 (3.7-9.2)	2.070 (0.770-2.560)	9.09	99
07+09+09+09	1.62	2.09	2.09	2.09	7.9 (3.7-9.2)	2.140 (0.810-2.670)	9.40	99
07+09+09+12	1.5	1.93	1.93	2.59	7.95 (3.7-9.2)	2.210 (0.810-2.650)	9.71	99
07+09+09+18	1.3	1.67	1.67	3.34	8.0 (3.7-9.2)	2.150 (0.790-2.620)	9.44	99
07+09+09+24	1.14	1.46	1.46	3.91	8.0 (3.7-9.2)	2.130 (0.770-2.590)	9.35	99
07+09+12+12	1.4	1.8	2.4	2.4	8.0 (3.7-9.2)	2.210 (0.810-2.620)	9.71	99
07+09+12+18	1.21	1.56	2.08	3.13	8.0 (3.7-9.2)	2.120 (0.790-2.590)	9.31	99
07+09+12+24	1.07	1.38	1.84	3.69	8.0 (3.7-9.2)	2.100 (0.770-2.560)	9.22	99
07+12+12+12	1.3	2.23	2.23	2.23	8.0 (3.7-9.2)	2.200 (0.810-2.610)	9.66	99
07+12+12+18	1.14	1.95	1.95	2.93	8.0 (3.7-9.2)	2.080 (0.790-2.580)	9.13	99
09+09+09+09	1.97	1.97	1.97	1.97	7.9 (3.7-9.2)	2.140 (0.810-2.670)	9.40	99
09+09+09+12	1.84	1.84	1.84	2.46	8.0 (3.7-9.2)	2.220 (0.810-2.650)	9.75	99
09+09+09+18	1.6	1.6	1.6	3.2	8.0 (3.7-9.2)	2.150 (0.790-2.620)	9.44	99
09+09+09+24	1.41	1.41	1.41	3.76	8.0 (3.7-9.2)	2.130 (0.770-2.590)	9.35	99
09+09+12+12	1.56	1.75	2.34	2.34	8.0 (3.7-9.2)	2.210 (0.810-2.620)	9.71	99
09+09+12+18	1.5	1.5	2.0	3.0	8.0 (3.7-9.2)	2.120 (0.790-2.590)	9.31	99
09+12+12+12	1.6	2.13	2.13	2.13	8.0 (3.7-9.2)	2.200 (0.810-2.610)	9.66	99
12+12+12+12	2.0	2.0	2.0	2.0	8.0 (3.7-9.2)	2.190 (0.810-2.580)	9.62	99

NOTE: Electrical data is for outdoor unit only.

Indoor units combination	Heating capacity (kW)					Outdoor unit power consumption (kW)	Current (A)	Power factor (%)
	Unit A	Unit B	Unit C	Unit D	Total			
07	3.3	-	-	-	3.3 (1.2-4.2)	1.050 (0.340-1.380)	4.61	99
09	3.6	-	-	-	3.6 (1.2-4.5)	1.110 (0.340-1.510)	4.87	99
12	4.0	-	-	-	4.0 (1.2-4.8)	1.210 (0.330-1.570)	5.31	99
18	7.2	-	-	-	7.2 (1.4-8.2)	2.270 (0.330-2.710)	9.97	99
24	7.9	-	-	-	7.9 (1.4-8.6)	2.700 (0.330-3.060)	11.86	99
26	8.6	-	-	-	8.6 (1.6-9.2)	3.220 (0.360-3.520)	14.14	99
07+07	3.3	3.3	-	-	6.6 (1.8-7.2)	2.020 (0.480-2.760)	8.87	99
07+09	3.02	3.88	-	-	6.9 (1.8-8.7)	2.120 (0.480-3.000)	9.31	99
07+12	2.69	4.61	-	-	7.3 (1.8-9.2)	2.130 (0.480-3.110)	9.35	99
07+18	2.49	6.41	-	-	8.9 (1.8-9.9)	2.470 (0.460-3.140)	10.85	99
07+24	2.12	7.28	-	-	9.4 (1.8-9.9)	2.710 (0.460-3.140)	11.90	99
07+26	1.99	7.41	-	-	9.4 (1.8-9.9)	2.710 (0.460-3.140)	11.90	99
09+09	3.6	3.6	-	-	7.2 (1.8-9.1)	2.170 (0.480-3.140)	9.53	99
09+12	3.26	4.34	-	-	7.6 (1.8-9.5)	2.210 (0.480-3.230)	9.71	99
09+18	3.0	6.0	-	-	9.0 (1.8-10.1)	2.520 (0.460-3.260)	11.07	99
09+24	2.56	6.84	-	-	9.4 (1.8-10.1)	2.710 (0.460-3.260)	11.90	99
09+26	2.42	6.98	-	-	9.4 (1.8-10.1)	2.710 (0.460-3.260)	11.90	99
12+12	4.0	4.0	-	-	8.0 (1.8-9.8)	2.370 (0.480-3.230)	10.41	99
12+18	3.76	5.64	-	-	9.4 (1.8-10.5)	2.560 (0.460-3.420)	11.24	99
12+24	3.13	6.27	-	-	9.4 (1.8-10.5)	2.560 (0.460-3.420)	11.24	99
12+26	2.97	6.43	-	-	9.4 (1.8-10.5)	2.560 (0.460-3.420)	11.24	99
18+18	4.7	4.7	-	-	9.4 (1.9-11.2)	2.370 (0.440-3.320)	10.41	99
18+24	4.03	5.37	-	-	9.4 (1.9-11.2)	2.370 (0.440-3.320)	10.41	99
18+26	3.85	5.55	-	-	9.4 (1.9-11.2)	2.370 (0.440-3.320)	10.41	99
24+24	4.7	4.7	-	-	9.4 (1.9-11.2)	2.370 (0.440-3.320)	10.41	99
24+26	4.51	4.89	-	-	9.4 (1.9-11.2)	2.370 (0.440-3.320)	10.41	99
07+07+07	2.9	2.9	2.9	-	8.7 (2.6-10.6)	2.150 (0.530-3.060)	9.44	99
07+07+09	2.67	2.67	3.44	-	8.8 (2.6-11.1)	2.170 (0.530-3.330)	9.53	99
07+07+12	2.53	2.53	4.33	-	9.4 (2.6-11.6)	2.310 (0.530-3.400)	10.14	99
07+07+18	2.05	2.05	5.28	-	9.4 (2.6-11.6)	2.120 (0.510-3.330)	9.31	99
07+07+24	1.73	1.73	5.93	-	9.4 (2.6-11.6)	2.120 (0.510-3.330)	9.31	99
07+07+26	1.64	1.64	6.11	-	9.4 (2.6-11.6)	2.120 (0.510-3.330)	9.31	99
07+09+09	2.49	3.2	3.2	-	8.9 (2.6-11.6)	2.170 (0.530-3.420)	9.53	99
07+09+12	2.35	3.02	4.02	-	9.4 (2.6-11.6)	2.270 (0.530-3.410)	9.97	99

NOTE: Electrical data is for outdoor unit only.

Indoor units combination	Heating capacity (kW)					Outdoor unit power consumption (kW)	Current (A)	Power factor (%)
	Unit A	Unit B	Unit C	Unit D	Total			
07+09+18	1.93	2.48	4.97	-	9.4 (2.6-11.6)	2.100 (0.510-3.330)	9.22	99
07+09+24	1.64	2.11	5.64	-	9.4 (2.6-11.6)	2.100 (0.510-3.330)	9.22	99
07+09+26	1.56	2.01	5.81	-	9.4 (2.6-11.6)	2.100 (0.510-3.330)	9.22	99
07+12+12	2.12	3.63	3.63	-	9.4 (2.6-11.6)	2.210 (0.530-3.400)	9.71	99
07+12+18	1.77	3.04	4.57	-	9.4 (2.7-11.6)	2.050 (0.510-3.230)	9.00	99
07+12+24	1.53	2.62	5.24	-	9.4 (2.7-11.6)	2.050 (0.510-3.230)	9.00	99
07+12+26	1.46	2.5	5.43	-	9.4 (2.7-11.6)	2.050 (0.510-3.230)	9.00	99
07+18+18	1.53	3.93	3.93	-	9.4 (2.7-11.6)	1.960 (0.490-3.100)	8.61	99
07+18+24	1.34	3.45	4.6	-	9.4 (2.7-11.6)	1.960 (0.490-3.100)	8.61	99
07+18+26	1.29	3.31	4.79	-	9.4 (2.7-11.6)	1.960 (0.490-3.100)	8.61	99
09+09+09	3.0	3.0	3.0	-	9.0 (2.6-11.6)	2.170 (0.530-3.420)	9.53	99
09+09+12	2.82	2.82	3.76	-	9.4 (2.6-11.6)	2.250 (0.530-3.410)	9.88	99
09+09+18	2.35	2.35	4.7	-	9.4 (2.6-11.6)	2.090 (0.510-3.320)	9.18	99
09+09+24	2.01	2.01	5.37	-	9.4 (2.6-11.6)	2.090 (0.510-3.320)	9.18	99
09+09+26	1.92	1.92	5.55	-	9.4 (2.6-11.6)	2.090 (0.510-3.320)	9.18	99
09+12+12	2.56	3.41	3.41	-	9.4 (2.6-11.6)	2.190 (0.530-3.400)	9.62	99
09+12+18	2.16	2.89	4.33	-	9.4 (2.7-11.6)	2.030 (0.510-3.230)	8.92	99
09+12+24	1.88	2.5	5.01	-	9.4 (2.7-11.6)	2.030 (0.510-3.230)	8.92	99
09+12+26	1.8	2.4	5.2	-	9.4 (2.7-11.6)	2.030 (0.510-3.230)	8.92	99
09+18+18	1.88	3.76	3.76	-	9.4 (2.7-11.6)	1.940 (0.490-3.100)	8.52	99
09+18+24	1.65	3.31	4.42	-	9.4 (2.7-11.6)	1.940 (0.490-3.100)	8.52	99
12+12+12	3.13	3.13	3.13	-	9.4 (2.6-11.6)	2.170 (0.530-3.380)	9.53	99
12+12+18	2.68	2.68	4.02	-	9.4 (2.7-11.6)	2.010 (0.510-3.160)	8.83	99
12+12+24	2.35	2.35	4.7	-	9.4 (2.7-11.6)	2.010 (0.510-3.160)	8.83	99
12+12+26	2.25	2.25	4.88	-	9.4 (2.7-11.6)	2.010 (0.510-3.160)	8.83	99
12+18+18	2.35	3.52	3.52	-	9.4 (2.7-11.6)	1.920 (0.490-3.030)	8.43	99
12+18+24	2.08	3.13	4.17	-	9.4 (2.7-11.6)	1.920 (0.490-3.030)	8.43	99
07+07+07+07	2.35	2.35	2.35	2.35	9.4 (3.4-11.6)	2.020 (0.590-3.420)	8.87	99
07+07+07+09	2.19	2.19	2.19	2.82	9.4 (3.4-11.6)	1.990 (0.590-3.410)	8.74	99
07+07+07+12	1.99	1.99	1.99	3.41	9.4 (3.4-11.6)	1.960 (0.590-3.390)	8.61	99
07+07+07+18	1.68	1.68	1.68	4.33	9.4 (3.5-11.6)	1.910 (0.580-3.260)	8.39	99
07+07+07+24	1.46	1.46	1.46	5.01	9.4 (3.5-11.6)	1.910 (0.580-3.260)	8.39	99
07+07+07+26	1.4	1.4	1.4	5.2	9.4 (3.5-11.6)	1.910 (0.580-3.260)	8.39	99
07+07+09+09	2.05	2.05	2.64	2.64	9.4 (3.4-11.6)	1.980 (0.590-3.400)	8.70	99

NOTE: Electrical data is for outdoor unit only.

Indoor units combination	Heating capacity (kW)					Outdoor unit power consumption (kW)	Current (A)	Power factor (%)
	Unit A	Unit B	Unit C	Unit D	Total			
07+07+09+12	1.88	1.88	2.41	3.22	9.4 (3.4-11.6)	1.940 (0.590-3.390)	8.52	99
07+07+09+18	1.6	1.6	2.06	4.12	9.4 (3.5-11.6)	1.890 (0.580-3.270)	8.30	99
07+07+09+24	1.4	1.4	1.8	4.8	9.4 (3.5-11.6)	1.890 (0.580-3.270)	8.30	99
07+07+09+26	1.34	1.34	1.72	4.98	9.4 (3.5-11.6)	1.890 (0.580-3.270)	8.30	99
07+07+12+12	1.73	1.73	2.96	2.96	9.4 (3.4-11.6)	1.910 (0.590-3.340)	8.39	99
07+07+12+18	1.49	1.49	2.56	3.84	9.4 (3.5-11.6)	1.820 (0.580-3.220)	7.99	99
07+07+12+24	1.31	1.31	2.25	4.51	9.4 (3.5-11.6)	1.820 (0.580-3.220)	7.99	99
07+07+18+18	1.31	1.31	3.38	3.38	9.4 (3.4-11.6)	1.750 (0.550-3.130)	7.69	99
07+09+09+09	1.93	2.48	2.48	2.48	9.4 (3.4-11.6)	1.960 (0.590-3.390)	8.61	99
07+09+09+12	1.77	2.28	2.28	3.04	9.4 (3.4-11.6)	1.920 (0.590-3.370)	8.43	99
07+09+09+18	1.53	1.96	1.96	3.93	9.4 (3.5-11.6)	1.870 (0.580-3.230)	8.21	99
07+09+09+24	1.34	1.72	1.72	4.6	9.4 (3.5-11.6)	1.870 (0.580-3.230)	8.21	99
07+09+12+12	1.64	2.11	2.82	2.82	9.4 (3.4-11.6)	1.890 (0.590-3.320)	8.30	99
07+09+12+18	1.43	1.83	2.45	3.67	9.4 (3.5-11.6)	1.800 (0.580-3.200)	7.91	99
07+09+12+24	1.26	1.62	2.16	4.33	9.4 (3.5-11.6)	1.800 (0.580-3.200)	7.91	99
07+12+12+12	1.53	2.62	2.62	2.62	9.4 (3.4-11.6)	1.860 (0.590-3.280)	8.17	99
07+12+12+18	1.34	2.3	2.3	3.45	9.4 (3.5-11.6)	1.780 (0.580-3.210)	7.82	99
09+09+09+09	2.35	2.35	2.35	2.35	9.4 (3.4-11.6)	1.950 (0.590-3.390)	8.56	99
09+09+09+12	2.16	2.16	2.16	2.89	9.4 (3.4-11.6)	1.910 (0.590-3.350)	8.39	99
09+09+09+18	1.88	1.88	1.88	3.76	9.4 (3.5-11.6)	1.860 (0.580-3.210)	8.17	99
09+09+09+24	1.65	1.65	1.65	4.42	9.4 (3.5-11.6)	1.860 (0.580-3.210)	8.17	99
09+09+12+12	1.83	2.06	2.75	2.75	9.4 (3.4-11.6)	1.870 (0.590-3.300)	8.21	99
09+09+12+18	1.76	1.76	2.35	3.52	9.4 (3.5-11.6)	1.780 (0.580-3.190)	7.82	99
09+12+12+12	1.88	2.5	2.5	2.5	9.4 (3.4-11.6)	1.840 (0.590-3.260)	8.08	99
12+12+12+12	2.35	2.35	2.35	2.35	9.4 (3.4-11.6)	1.930 (0.590-3.230)	8.48	99

Outdoor model		MXZ-A14WV - [E1]		MXZ-A18WV - [E1]		
Outdoor unit power supply		Single phase 230V,50Hz		Single phase 230V,50Hz		
System	Indoor units number	2		2		
	Piping total length	m	Max. 30 (chargeless 20)		Max. 30 (chargeless 20)	
	Connecting pipe length	m	Max. 20		Max. 20	
	Height difference (Indoor ~ Outdoor)	m	10		10	
	Height difference (Indoor ~ Indoor)	m	10		10	
Function		Cooling	Heating	Cooling	Heating	
Capacity	Capacity [Rated (Min.~Max.) Hz]*1	kW	4.0 (1.53~4.5)	4.5 (1.56~5.0)	5.4 (1.55~6.0)	6.6 (1.58~7.2)
	Dehumidification	ℓ /h	—	—	—	—
	Outdoor air flow	m ³ /h	2,460		2,460	
*2 Electrical data	Power outlet	A	20		20	
	Running current *1	A	5.55	5.12	8.98	8.55
	Power input	W	1,150 (370~1,330)	1,060 (300~1,190)	1,860 (370~2,130)	1,770 (290~1,850)
	Auxiliary heater	A(kW)	—		—	
	Crankcase heater	W	—		—	
	Power factor *1	%	90.0		90.0	
	Starting current *1	A	5.55		8.98	
	Compressor motor current	A	4.98	4.55	8.41	7.98
	Fan motor current	A	0.57		0.57	
Coefficient of performance (C.O.P)			3.48	4.25	2.90	3.73
Compressor	Model	SNV-092FJYH (ROTARY)		SNV-092FJYH (ROTARY)		
	Output	W	1,100		1,450	
	Winding resistance (at 20°C)	Ω	U-V 2.56 V-W 2.56 W-U 2.56		U-V 2.56 V-W 2.56 W-U 2.56	
Fan motor	Model	RA6V49		RA6V49		
	Winding resistance (at 20°C)	Ω	WHT-BLK 139.9 BLK-YLW 34.2 BLK-RED 205.3		WHT-BLK 139.9 BLK-YLW 34.2 BLK-RED 205.3	
Dimensions W×H×D		mm	840(+69)×640×330		840(+69)×640×330	
Weight		kg	52		52	
Special remarks	Sound level (High/Low*) *3	dB	48/44*	49/45*	49/44*	50/45*
	Fan speed (High/Low*) *3	rpm	725/620*		725/620*	
	Fan speed regulator *3		2		2	
	Refrigerant filling capacity (R410A)	kg	1.75		1.75	
	Refrigerating oil (Model)	cc	450 (NEO22)		450 (NEO22)	
	Thermistor RT61	kΩ	13.4 (at 100°C)		13.4 (at 100°C)	
	Thermistor RT62	kΩ	10.0 (at 25°C)		10.0 (at 25°C)	
	Thermistor RT63	kΩ	10.0 (at 25°C)		10.0 (at 25°C)	
	Thermistor RT6A,6B	kΩ	10.0 (at 25°C)		10.0 (at 25°C)	
	Thermistor RT65	kΩ	17.0 (at 50°C)		17.0 (at 50°C)	
Thermistor RT68	kΩ	10.0 (at 25°C)		10.0 (at 25°C)		

NOTE: •Test conditions are based on ISO 5151 (Refrigerant piping length (one way) :5m)

•Refer to "INDOOR/OUTDOOR CORRESPONDENCE TABLE" of page 6 for the combination.

* Reference value

*1 Measured under rated operating frequency.

*2 Electrical data is for only outdoor unit.

*3 These specifications are when all indoor units are operating.

TEST CONDITIONS COOLING INDOOR DB27.0°C WB19.0°C
 OUTDOOR DB35.0°C WB24.0°C
 HEATING INDOOR DB20.0°C
 OUTDOOR DB 7.0°C WB 6.0°C

Outdoor model			MXZ-A26WV - [E1]		MXZ-A32WV - [E1]		
Outdoor unit power supply			Single phase 230V,50Hz		Single phase 230V,50Hz		
System	Indoor units number		2 to 3		2 to 4		
	Piping total length	m	Max. 50		Max. 70		
	Connecting pipe length	m	Max. 25		Max. 25		
	Height difference (Indoor ~ Outdoor)	m	10		10		
	Height difference (Indoor ~ Indoor)	m	10		10		
Function			Cooling	Heating	Cooling	Heating	
Capacity	Capacity [Rated (Min.~Max.) Hz]*1	kW	7.2 (2.9~8.5)	9.0 (2.6~11.0)	8.0 (3.7~9.2)	9.4 (3.4~11.6)	
	Dehumidification	ℓ /h	—	—	—	—	
	Outdoor air flow	m³ /h	2,530	2,630	2,530	2,630	
*2 Electrical data	Power outlet	A	25		25		
	Running current *1	A	9.18	9.44	9.62	8.48	
	Power input	W	2,090 (720~2,560)	2,150 (530~3,050)	2,190 (810~2,580)	1,930 (590~3,230)	
	Auxiliary heater	A(kW)	—		—		
	Crankcase heater	W	—		—		
	Power factor *1	%	99.0		99.0		
	Starting current *1	A	9.44		9.62		
	Compressor motor current	A	8.98	9.24	9.42	8.28	
Fan motor current	A	0.2		0.2			
Coefficient of performance(C.O.P)			3.44	4.19	3.65	4.87	
Compressor	Model		TNB220FMCH (ROTARY)		TNB220FMCH (ROTARY)		
	Output	W	2,000		2,100		
	Winding resistance(at 20°C)	Ω	U-V 1.41 V-W 1.41 W-U 1.41		U-V 1.41 V-W 1.41 W-U 1.41		
Fan motor	Model		PM8H60-UA		PM8H60-UA		
	Winding resistance(at 20°C)	Ω	BLK-WHT 15.2 WHT-RED 15.2 RED-BLK 15.2		BLK-WHT 15.2 WHT-RED 15.2 RED-BLK 15.2		
Dimensions W×H×D			900×900×320 (+35)		900×900×320 (+35)		
Weight			69		70		
Special remarks	Sound level (High/Low*) *3		46/44 *	48/46 *	46/44 *	48/46 *	
	Fan speed (High/Low*) *3		550/490 *	560/490 *	550/490 *	560/490 *	
	Fan speed regulator *3			2		2	
	Refrigerant filling capacity(R410A)		kg		3.5		
	Refrigerating oil (Model)		cc		870 (NEO22)		
	Thermistor RT61		kΩ		13.4 (at 100°C)		
	Thermistor RT62		kΩ		10.0 (at 25°C)		
	Thermistor RT63		kΩ		10.0 (at 25°C)		
	Thermistor RT68		kΩ		10.0 (at 25°C)		
	Thermistor RT6A		kΩ		10.0 (at 25°C)		
	Thermistor RT6B		kΩ		10.0 (at 25°C)		
	Thermistor RT6C		kΩ		10.0 (at 25°C)		
	Thermistor RT6D		kΩ		10.0 (at 25°C)		
Thermistor RT65		kΩ		17.0 (at 50°C)			

NOTE: •Test conditions are based on ISO 5151 (Refrigerant piping length (one way) :5m)

•Refer to "INDOOR/OUTDOOR CORRESPONDENCE TABLE" of page 7 or 8 for the combination.

* Reference value

*1 Measured under rated operating frequency.

*2 Electrical data is for only outdoor unit.

*3 These specifications are when all indoor units are operating.

TEST CONDITIONS COOLING INDOOR DB27.0°C WB19.0°C
 OUTDOOR DB35.0°C WB24.0°C
 HEATING INDOOR DB20.0°C
 OUTDOOR DB 7.0°C WB 6.0°C

NOISE CRITERIA CURVES

MXZ-A14WV - [E1]

FAN SPEED	FUNCTION	SPL(dB(A))	LINE
High	Cooling	48	●—●
High	Heating	49	○—○

Test conditions.
 Cooling :DB 35°C WB 24°C
 Heating :DB 7°C WB 6°C

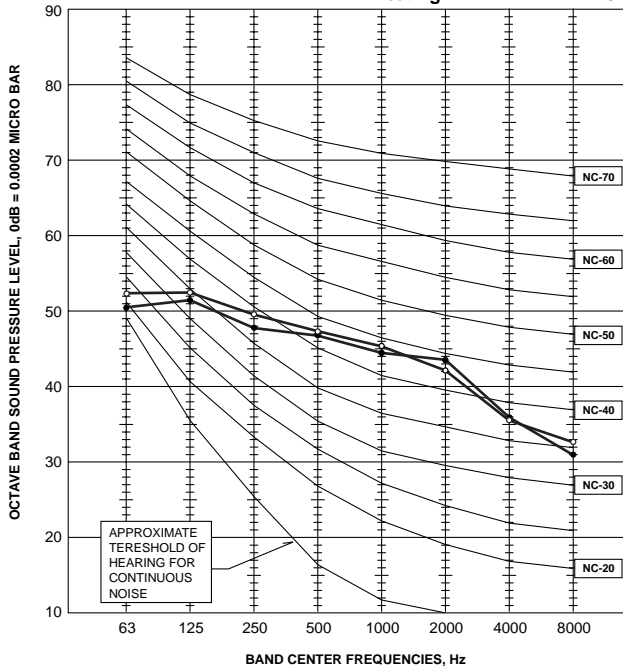

MXZ-A18WV - [E1]

FAN SPEED	FUNCTION	SPL(dB(A))	LINE
High	Cooling	49	●—●
High	Heating	50	○—○

Test conditions.
 Cooling :DB 35°C WB 24°C
 Heating :DB 7°C WB 6°C

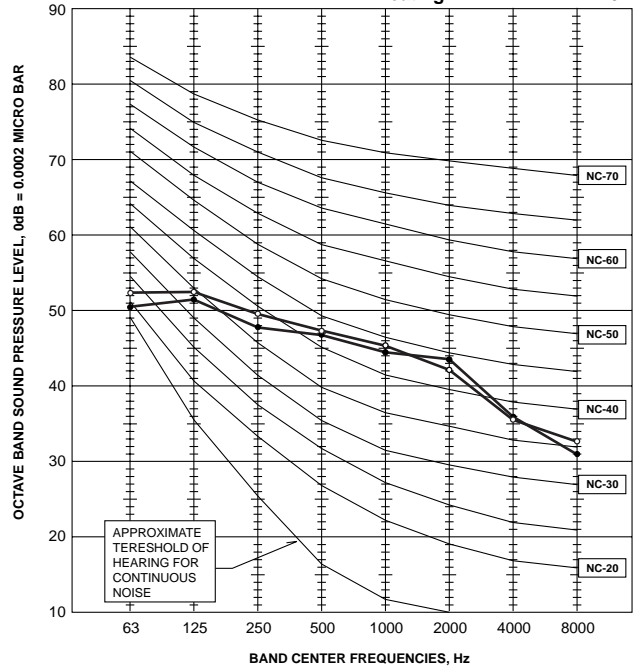

MXZ-A26WV - [E1]

FAN SPEED	FUNCTION	SPL(dB(A))	LINE
High	Cooling	46	●—●
High	Heating	48	○—○

MXZ-A32WV - [E1]

Test conditions.
 Cooling :DB 35°C WB 24°C
 Heating :DB 7°C WB 6°C

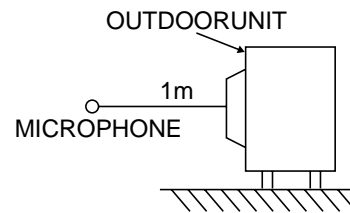
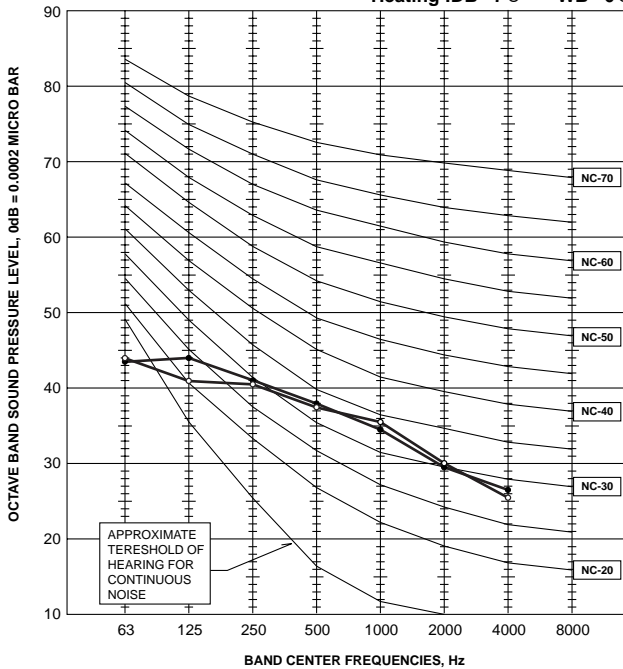

OUTDOOR UNIT

Unit: mm

MXZ-A14WV -E1

MXZ-A18WV -E1

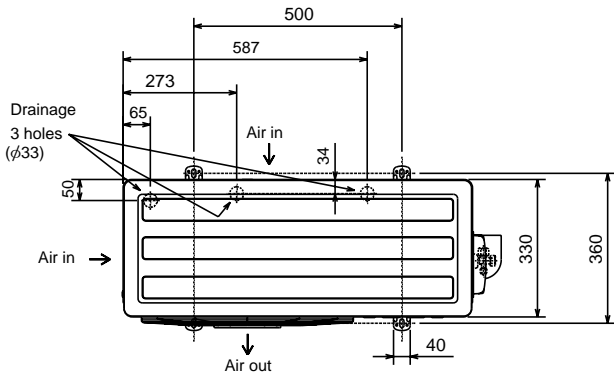

REQUIRED SPACE

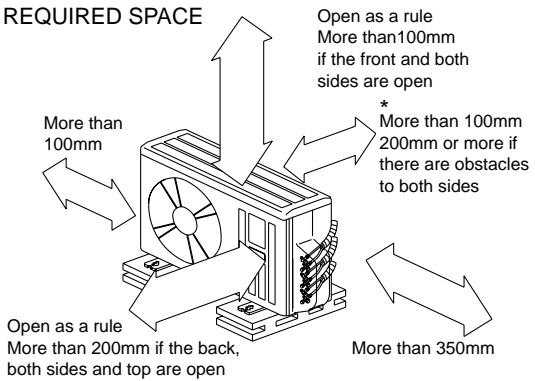

* Note:
The dimensions given along the arrows above are required to guarantee the air conditioner's performance. Install the unit in as wide a place as possible for later service or repairs.

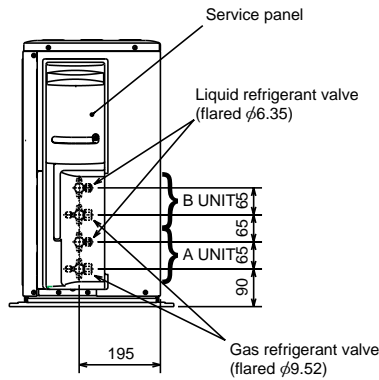
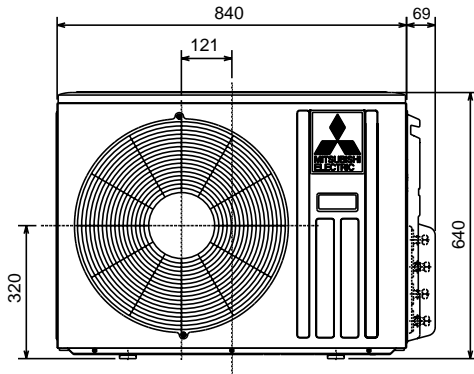

OUTDOOR UNIT

MXZ-A26WV -E1

Unit: mm

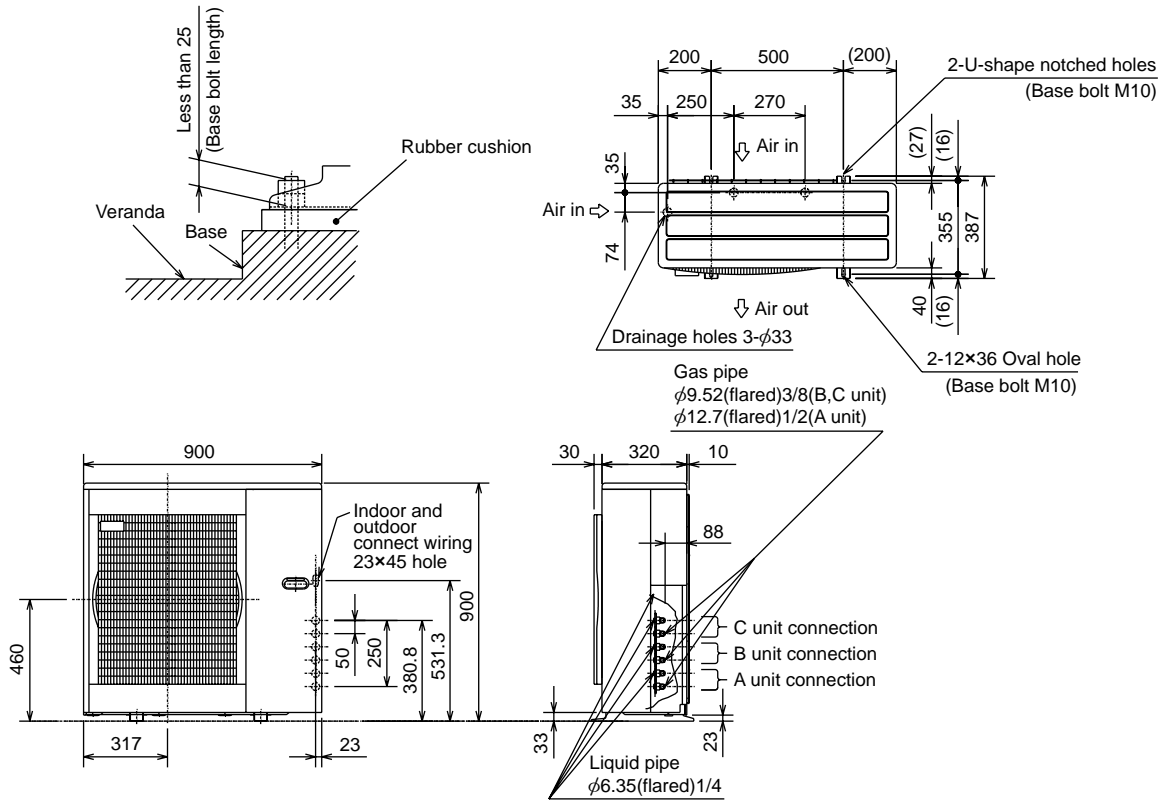

1. Installation space

Note : Leave front and both sides clearance fully.

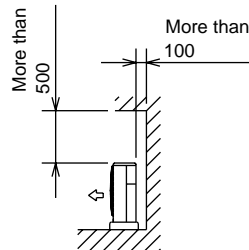

Note : Leave front and overhead clearance fully.

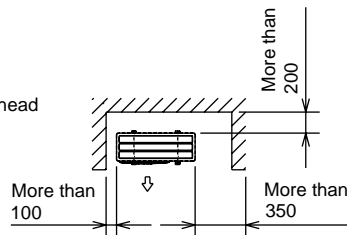

Note : Leave front, overhead and both sides clearance fully.

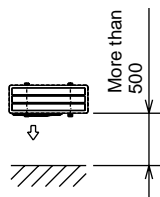

2. Service space

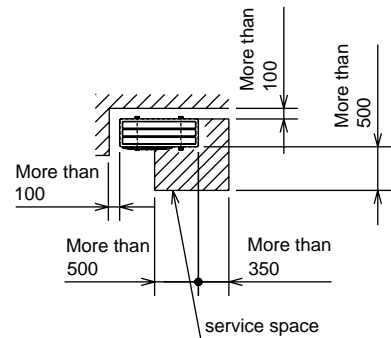

OUTDOOR UNIT

MXZ-A32WV - [E1]

Unit: mm

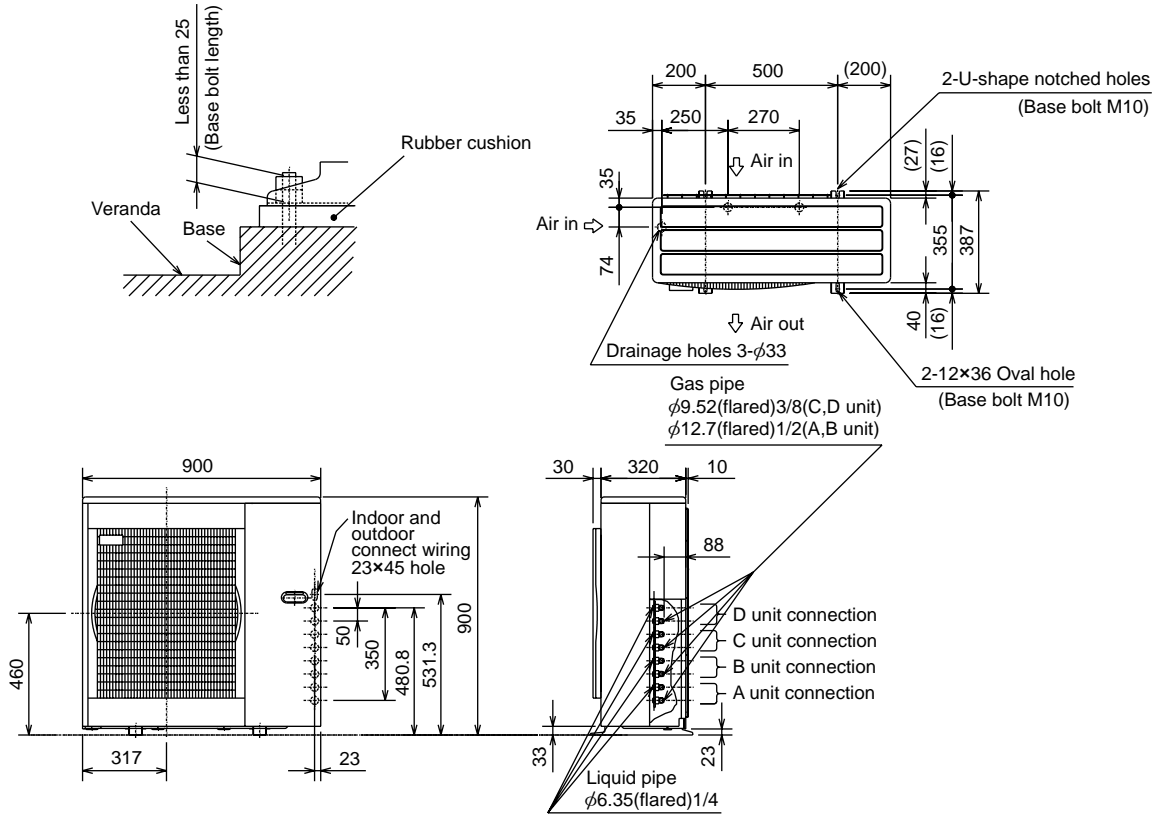

1. Installation space

Note : Leave front and both sides clearance fully.

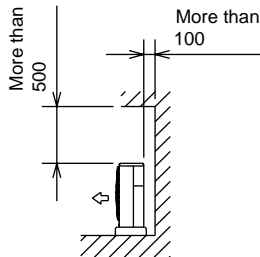

Note : Leave front and overhead clearance fully.

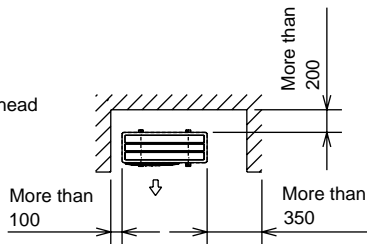

Note : Leave front, overhead and both sides clearance fully.

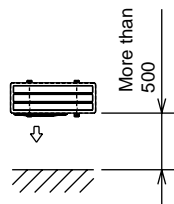

2. Service space

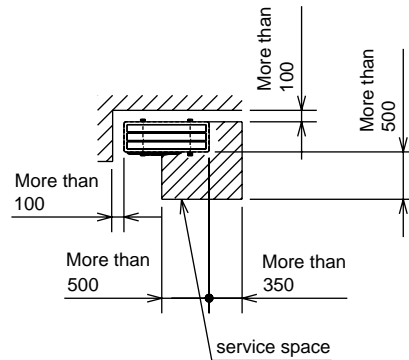

MXZ-A14WW -E1

MXZ-A18WW -E1

OUTDOOR UNIT

MODEL WIRING DIAGRAM

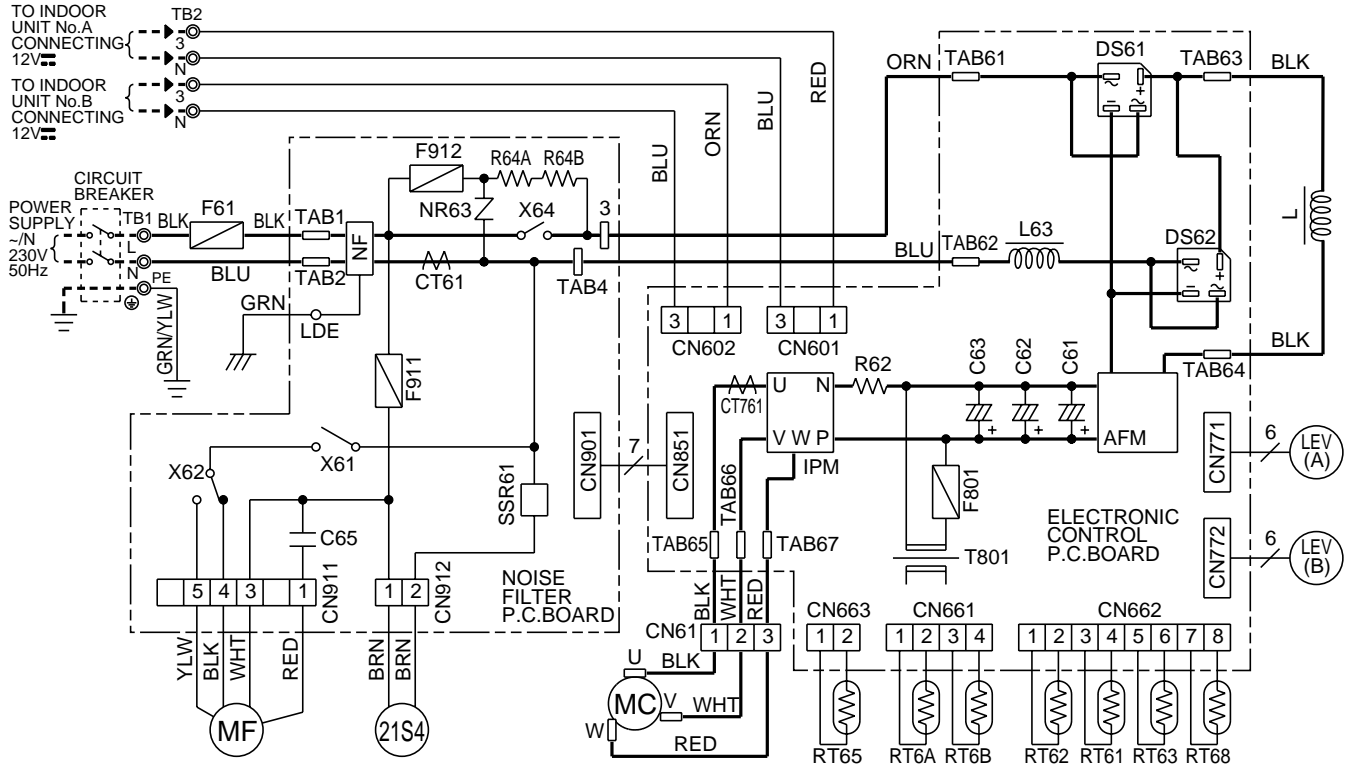

SYMBOL	NAME	SYMBOL	NAME	SYMBOL	NAME
AFM	ACTIVE FILTER MODULE	LEV(A)	EXPANSION VALVE A,COIL	R64A	RESISTOR
CT61	CURRENT TRANSFORMER	LEV(B)	EXPANSION VALVE B,COIL	R64B	RESISTOR
CT761	CURRENT TRANSFORMER	L63	NORMAL MODE CHOKE COIL	SSR61	SOLENOID COIL RELAY
C61	SMOOTHING CAPACITOR	MC	COMPRESSOR	TB1	TERMINAL BLOCK
C62	SMOOTHING CAPACITOR	MF	OUTDOOR FAN MOTOR	TB2	TERMINAL BLOCK
C63	SMOOTHING CAPACITOR	NF	NOISE FILTER	T801	TRANSFORMER
C65	OUTDOOR FAN CAPACITOR	NR63	VARISTOR	X61	FAN MOTOR RELAY
DS61	DIODE MODULE	RT6A	GAS PIPE TEMPERATURE A THERMISTOR	X62	FAN MOTOR RELAY
DS62	DIODE MODULE	RT6B	GAS PIPE TEMPERATURE B THERMISTOR	X64	RELAY
F61	FUSE (20A)	RT61	DISCHARGE TEMPERATURE THERMISTOR	21S4	R.V. COIL
F801	FUSE(1A)	RT62	DEFROST THERMISTOR	NOTES 1.About the indoor side electric wiring refer to the indoor unit electric wiring diagram for servicing. 2.Use copper conductors only(for field wiring). 3.Symbols below indicate. ◎:Terminal block □□:Connector	
F911	FUSE(1A)	RT63	EVAPORATOR TEMPERATURE THERMISTOR		
F912	FUSE(3.15A)	RT65	FIN TEMPERATURE THERMISTOR		
IPM	POWER TRANSISTOR MODULE	RT68	HIGH-PRESSURE PROTECT THERMISTOR		
L	REACTOR	R62	RESISTOR		

MXZ-A26WV - E1

OUTDOOR UNIT

MODEL WIRING DIAGRAM

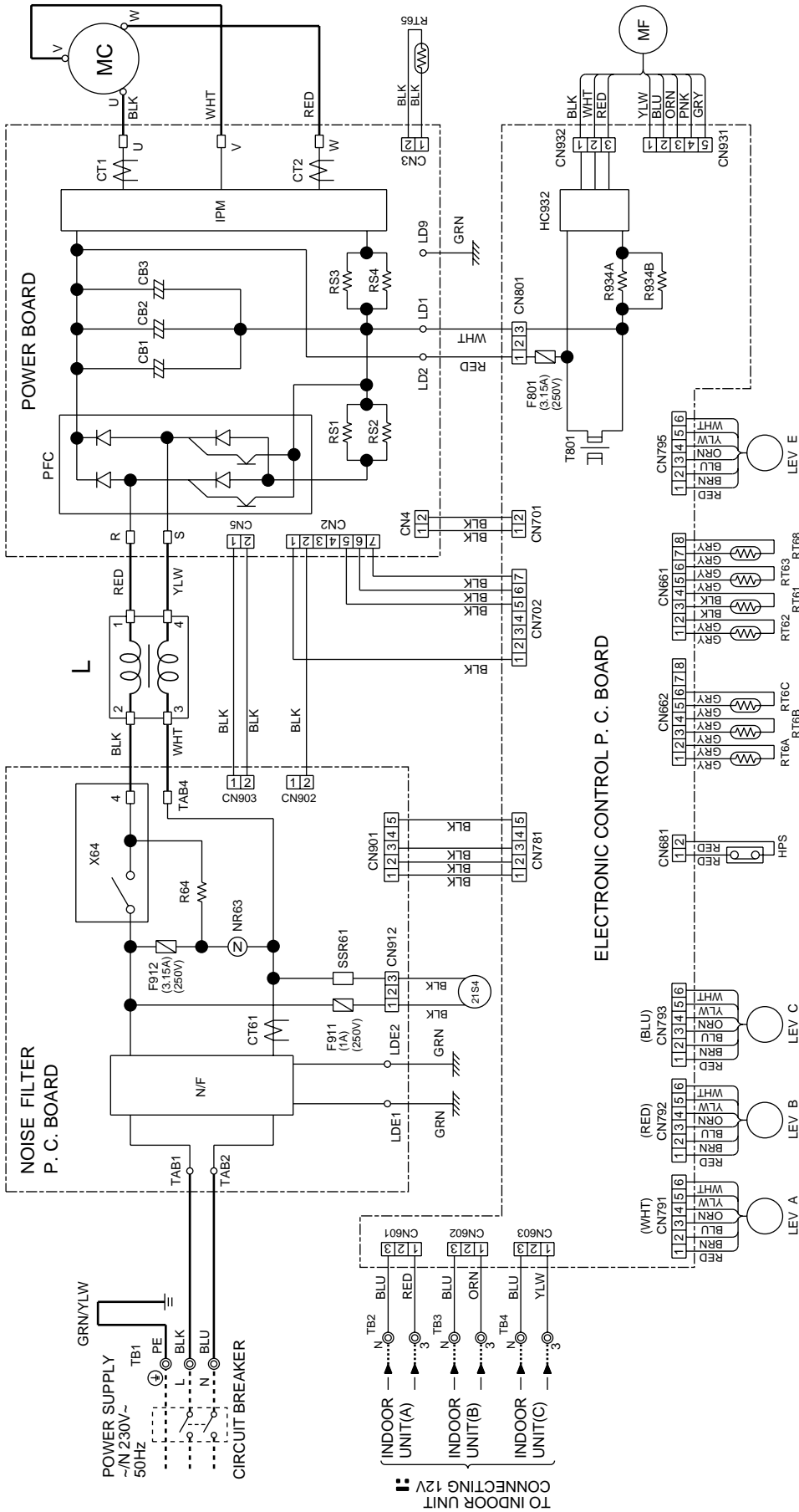

- NOTES:**
1. About the indoor side electric wiring refer to the indoor unit electric wiring diagram for servicing.
 2. Use copper conductors only (for field wiring).
 3. Symbols below indicate.
 - ⊙: Terminal block
 - : Connector

SYMBOL	NAME	SYMBOL	NAME	SYMBOL	NAME
CB1~3	SMOOTHING CAPACITOR	LEV E	EXPANSION VALVE	RT62	DEFROST THERMISTOR
CT1, 2	CURRENT TRANSFORMER	MC	COMPRESSOR	R T63	EVAPORATION TEMPERATURE THERMISTOR
CT61	CURRENT TRANSFORMER	MF	OUTDOOR FAN MOTOR (INNER FUSE)	R T65	FIN TEMPERATURE THERMISTOR
F801	FUSE (3.15A) (250V)	NR63	VARIATOR	RT68	OUTDOOR HEAT EXCHANGER TEMPERATURE THERMISTOR
F911	FUSE (1A) (250V)	N/F	NOISE FILTER	SSR61	SOLENOID COIL RELAY
F912	FUSE (3.15A) (250V)	PFC	POWER FACTOR CONTROLLER	T801	TRANSFORMER
HC932	FET ARRAY	R64	RESISTOR	TB1~4	TERMINAL BLOCK
HPS	HIGH PRESSURE SWITCH	R934A, B	RESISTOR	X64	RELAY
IPM	POWER TRANSISTOR MODULE	RS1~4	RESISTOR	2T54	R.V. COIL
L	REACTOR	RT6A-C	GAS PIPE TEMPERATURE THERMISTOR		
LEV A-C	EXPANSION VALVE	RT61	DISCHARGE TEMPERATURE THERMISTOR		

MXZ-A32WW -E1
OUTDOOR UNIT

MODEL WIRING DIAGRAM

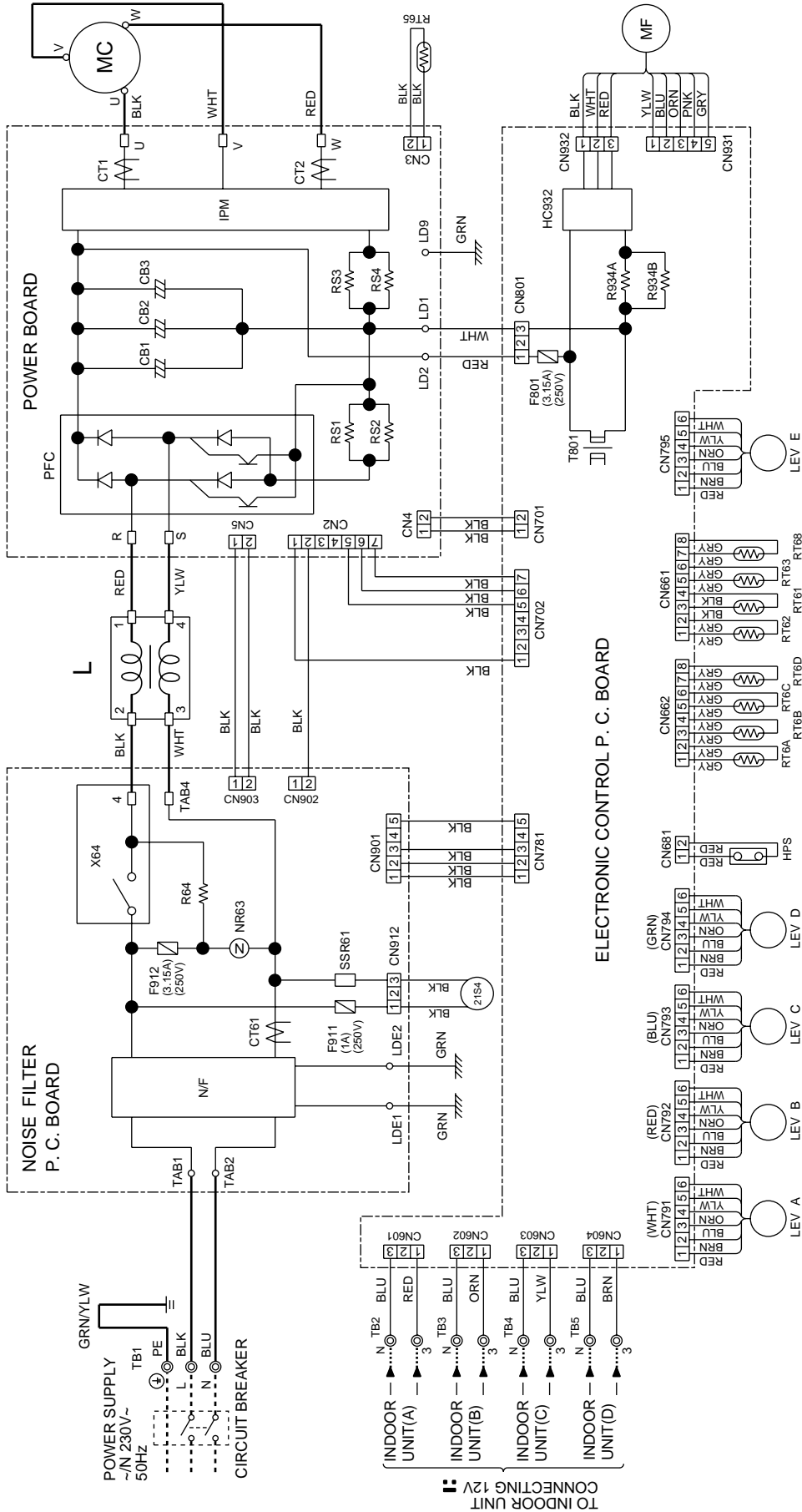

NOTES: 1. About the indoor side electric wiring refer to the indoor unit electric wiring diagram for servicing.
 2. Use copper conductors only (for field wiring).
 3. Symbols below indicate.
 ◎:Terminal block □□:Connector

SYMBOL	NAME	SYMBOL	NAME	SYMBOL	NAME
CB1-3	SMOOTHING CAPACITOR	LEV E	EXPANSION VALVE	RT62	DEFROST THERMISTOR
CT1, 2	CURRENT TRANSFORMER	MC	COMPRESSOR	RT63	EVAPORATION TEMPERATURE THERMISTOR
CT61	CURRENT TRANSFORMER	MF	OUTDOOR FAN MOTOR (INNER FUSE)	RT65	FIN TEMPERATURE THERMISTOR
F801	FUSE (3.15A) (250V)	NR/63	VARISTOR	RT68	OUTDOOR HEAT EXCHANGER TEMPERATURE THERMISTOR
F912	FUSE (1A) (250V)	PFC	POWER FACTOR CONTROLLER	SSR61	SOLENOID COIL RELAY
F912	FUSE (3.15A) (250V)	R64	RESISTOR	T801	TRANSFORMER
HC932	FET ARRAY	R934A, B	RESISTOR	TB1-5	TERMINAL BLOCK
HPS	HIGH PRESSURE SWITCH	RS1-4	RESISTOR	X64	RELAY
IPM	POWER TRANSISTOR MODULE	RT6A-D	GAS PIPE TEMPERATURE THERMISTOR	21S4	R.V. COIL
L	REACTOR	RT61	DISCHARGE TEMPERATURE THERMISTOR		

MXZ-A14WV - [E1]

Unit:mm

MXZ-A18WV - [E1]

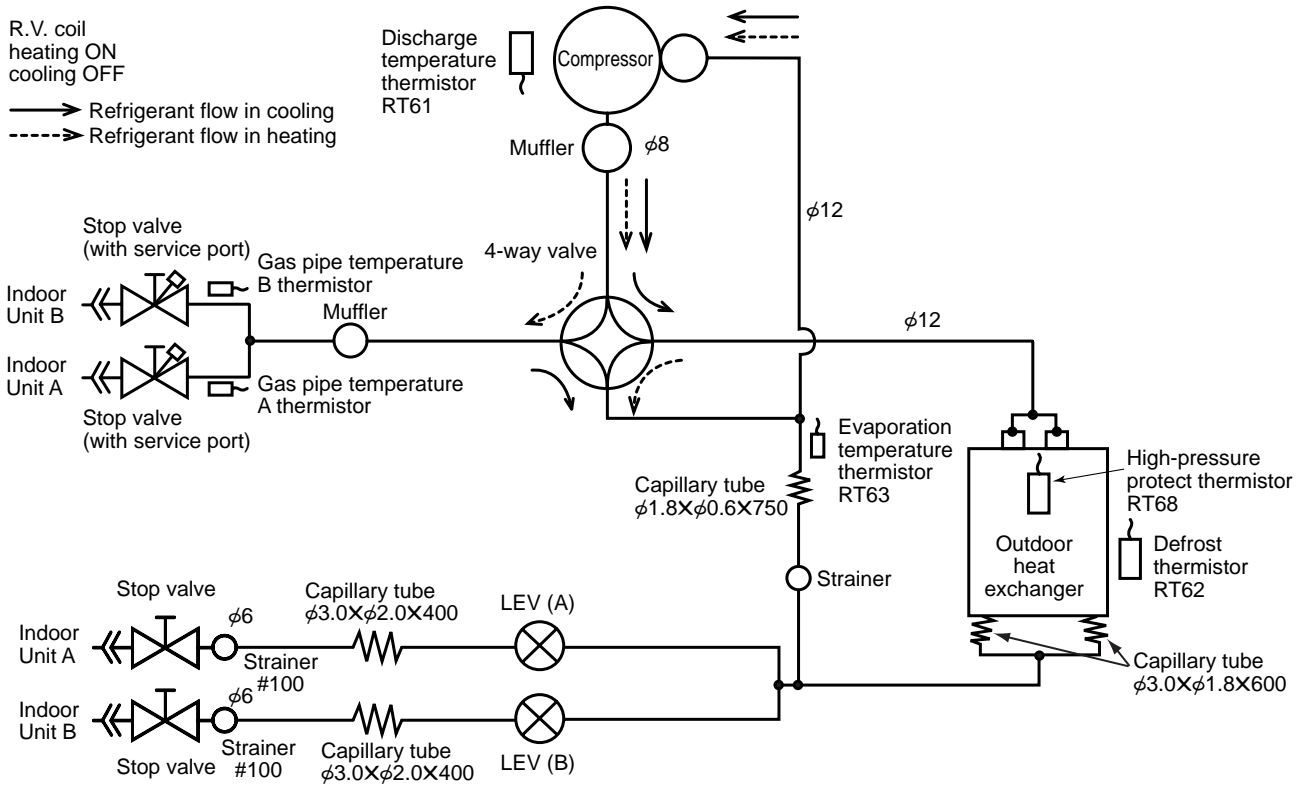

MAX REFRIGERANT PIPING LENGTH

Piping length each indoor unit (a, b)	20m
Total piping length (a+b)	30m
Height difference between units (H)	10m
Bending point for each unit	15
Total bending point	30

*It does not matter which unit is higher.

Outdoor unit precharged	Refrigerant piping length (one way, 2 unit total)		
	20m	25m	30m
1,750	0	100	200

Calculation : $Xg=20g/mx(\text{Refrigerant piping length(m)}-20)$

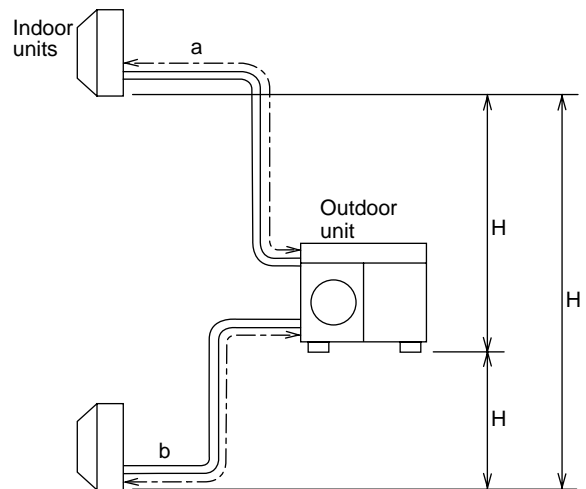

- Refrigerant pipe diameter is different according to indoor unit to be connected. When using extension pipes, refer to the tables below.
- When diameter of refrigerant pipe is different from that of outdoor unit union, use optional Different-diameter pipe. For further information on Different-diameter pipe, see page BACK COVER.

Unit : mm (inch)

class	Indoor unit		Extension pipe diameter	
	Pipe diameter			
07/09	Liquid	6.35(1/4)	Liquid	6.35(1/4)
	Gas	9.52(3/8)	Gas	9.52(3/8)
12	Liquid	6.35(1/4)	Liquid	6.35(1/4)
	Gas	12.7(1/2)	Gas	12.7(1/2)

Outdoor unit union diameter		
For		
Indoor unit A	Liquid	6.35(1/4)
	Gas	9.52(3/8)
Indoor unit B	Liquid	6.35(1/4)
	Gas	9.52(3/8)

MXZ-A26WV -E1

R.V. coil
 heating ON → Refrigerant flow in cooling
 cooling OFF - - - - - Refrigerant flow in heating

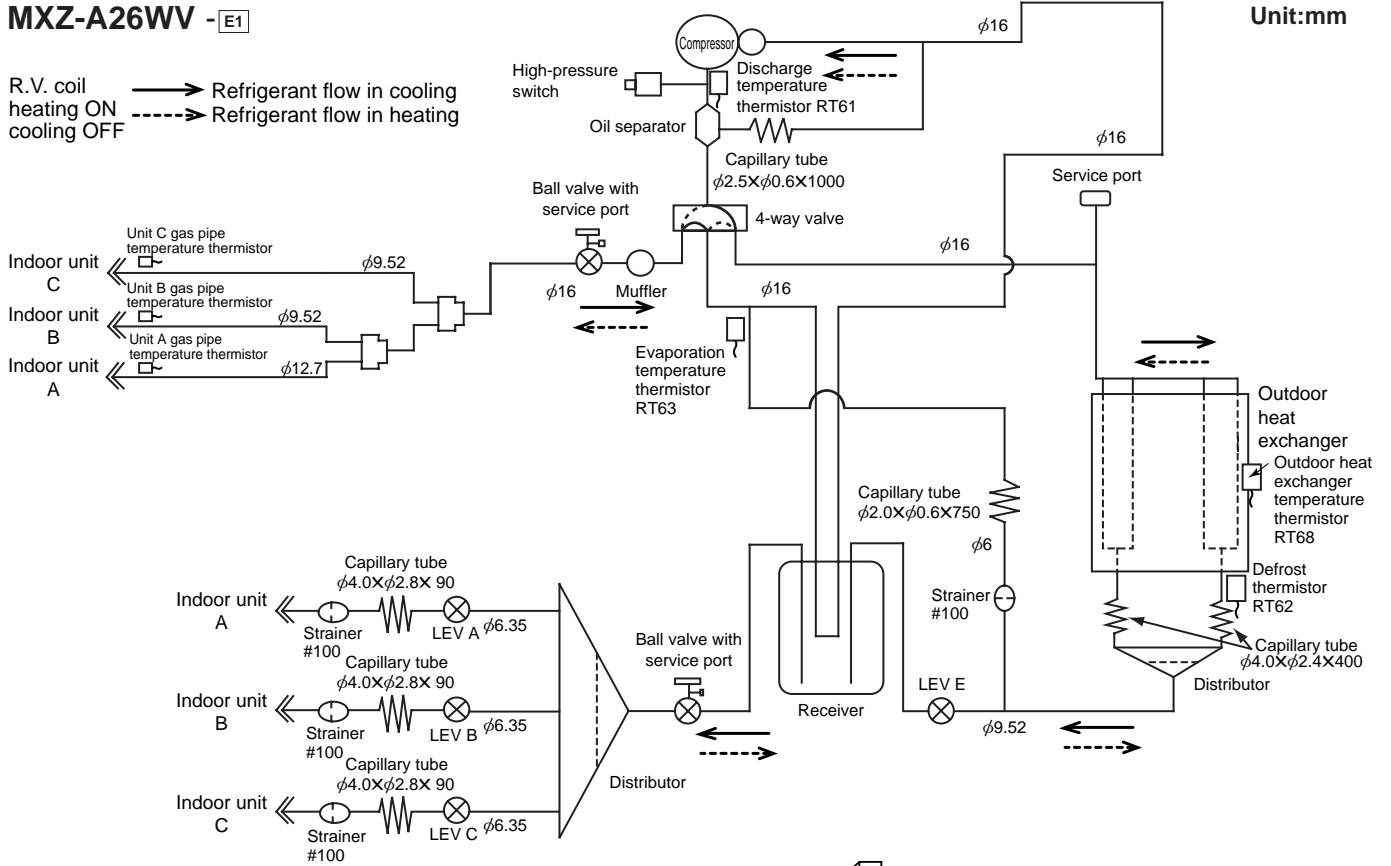

MAX REFRIGERANT PIPING LENGTH

Piping length each indoor unit (a, b, c)	25m
Total piping length (a+b+c)	50m
Height difference between units (H)	10m
Bending point for each unit	25
Total bending point	50

*It does not matter which unit is higher.

Outdoor unit precharged	Refrigerant piping length (one way, 3 unit total)		
	40m	45m	50m
3,500	0	100	200

Calculation : $Xg=20g/mx(\text{Refrigerant piping length}(m)-40)$

- Refrigerant pipe diameter is different according to indoor unit to be connected. When using extension pipes, refer to the tables below.
- When diameter of refrigerant pipe is different from that of outdoor unit union, use optional Different-diameter pipe. For further information on Different-diameter pipe, see page BACK COVER.

Unit : mm (inch)

class	Indoor unit		Extension pipe diameter	
		Pipe diameter		
07/09	Liquid	6.35(1/4)	Liquid	6.35(1/4)
	Gas	9.52(3/8)	Gas	9.52(3/8)
12	Liquid	6.35(1/4)	Liquid	6.35(1/4)
	Gas	9.52(3/8) or 12.7(1/2)	Gas	12.7(1/2)
18	Liquid	6.35(1/4)	Liquid	6.35(1/4)
	Gas	12.7(1/2)	Gas	12.7(1/2)
24	Liquid	6.35(1/4)	Liquid	6.35(1/4)
	Gas	15.88(5/8)	Gas	15.88(5/8)
26	Liquid	9.52(3/8)	Liquid	9.52(3/8)
	Gas	15.88(5/8)	Gas	15.88(5/8)

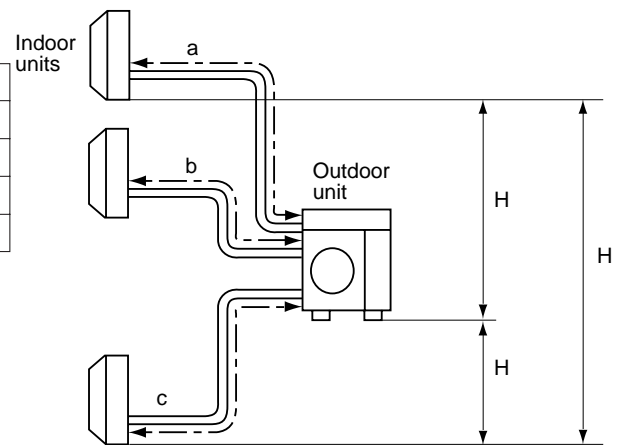

Outdoor unit union diameter		
For		
Indoor unit A	Liquid	6.35(1/4)
	Gas	12.7(1/2)
Indoor unit B	Liquid	6.35(1/4)
	Gas	9.52(3/8)
Indoor unit C	Liquid	6.35(1/4)
	Gas	9.52(3/8)

MXZ-A32WV - [E1]

Unit:mm

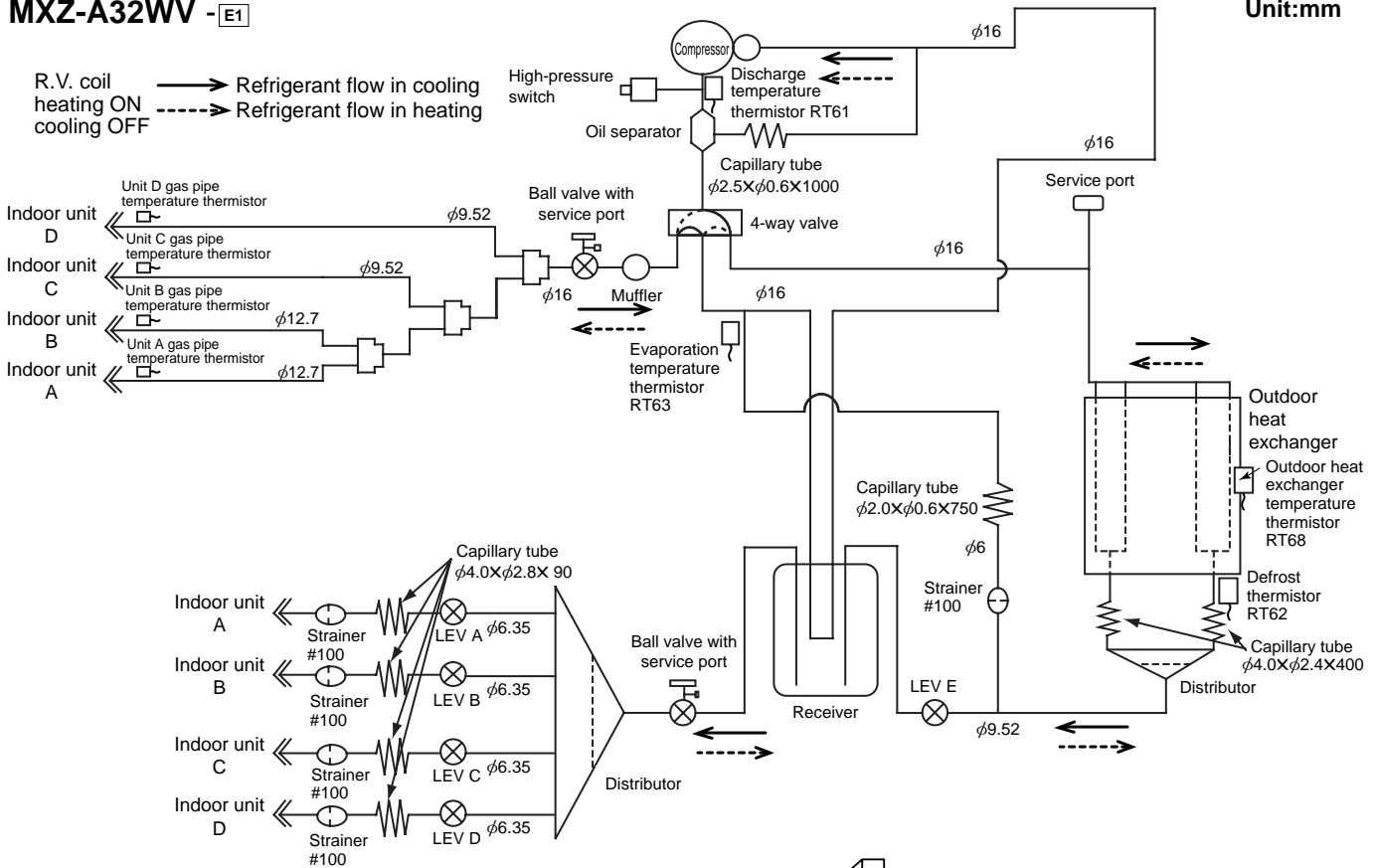

MAX REFRIGERANT PIPING LENGTH

Piping length each indoor unit (a, b, c, d)	25m
Total piping length (a+b+c+d)	70m
Height difference between units (H)	10m
Bending point for each unit	25
Total bending point	70

*It does not matter which unit is higher.

Outdoor unit precharged	Refrigerant piping length (one way, 4 unit total)			
	40m	50m	60m	70m
3,500	0	200	400	600

Calculation : $Xg=20g/mx(\text{Refrigerant piping length}(m)-40)$

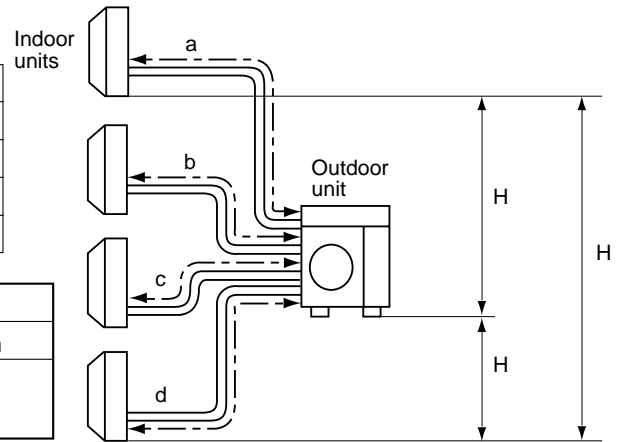

● Refrigerant pipe diameter is different according to indoor unit to be connected. When using extension pipes, refer to the tables below.

● When diameter of refrigerant pipe is different from that of outdoor unit union, use optional Different-diameter pipe.

For further information on Different-diameter pipe, see page BACK COVER.

Unit : mm (inch)

class	Indoor unit		Extension pipe diameter	
		Pipe diameter		
07/09	Liquid	6.35(1/4)	Liquid	6.35(1/4)
	Gas	9.52(3/8)	Gas	9.52(3/8)
12	Liquid	6.35(1/4)	Liquid	6.35(1/4)
	Gas	9.52(3/8) or 12.7(1/2)	Gas	12.7(1/2)
18	Liquid	6.35(1/4)	Liquid	6.35(1/4)
	Gas	12.7(1/2)	Gas	12.7(1/2)
24	Liquid	6.35(1/4)	Liquid	6.35(1/4)
	Gas	15.88(5/8)	Gas	15.88(5/8)
26	Liquid	9.52(3/8)	Liquid	9.52(3/8)
	Gas	15.88(5/8)	Gas	15.88(5/8)

Outdoor unit union diameter		
For		
Indoor unit A	Liquid	6.35(1/4)
	Gas	12.7(1/2)
Indoor unit B	Liquid	6.35(1/4)
	Gas	12.7(1/2)
Indoor unit C	Liquid	6.35(1/4)
	Gas	9.52(3/8)
Indoor unit D	Liquid	6.35(1/4)
	Gas	9.52(3/8)

MXZ-A14WV-^{E1}**MXZ-A18WV-^{E1}****MXZ-A26WV-^{E1}****MXZ-A32WV-^{E1}**

The standard data contained in these specifications apply only to the operation of the air conditioner under normal conditions, since operating conditions vary according to the areas where these units are installed. The following information has been provided to clarify the operating characteristics of the air conditioner under the conditions indicated by the performance curve.

(1) GUARANTEED VOLTAGE

198~264V

(2) AIR FLOW

Air flow should be set at MAX.

(3) MAIN READINGS

(1) Indoor intake air wet-bulb temperature :	°CWB	} Cooling
(2) Indoor outlet air wet-bulb temperature :	°CWB	
(3) Outdoor intake air dry-bulb temperature :	°CDB	
(4) Total input :	W	} Heating
(5) Indoor intake air dry-bulb temperature :	°CDB	
(6) Outdoor intake air wet-bulb temperature :	°CWB	
(7) Total input :	W	

Indoor air wet/dry-bulb temperature difference on the left side of the chart on page 34 shows the difference between the indoor intake air wet/dry-bulb temperature and the indoor outlet air wet/dry-bulb temperature for your reference at service.

How to measure the indoor air wet-bulb/dry-bulb temperature difference

1. Attach at least 2 sets of wet-and dry-bulb thermometers to the indoor air intake as shown in the figure, and at least 2 sets of wet-and dry-bulb thermometers to the indoor air outlet. The thermometers must be attached to the position where air speed is high.
2. Attach at least 2 sets of wet-and dry-bulb thermometers to the outdoor air intake. Cover the thermometers to prevent direct rays of the sun.
3. Check that the air filter is cleaned.
4. Open windows and doors of room.
5. Press the EMERGENCY OPERATION switch once(twice) to start the EMERGENCY COOL (HEAT) MODE.
6. When system stabilizes after more than 15 minutes, measure temperature and take an average temperature.
7. 10 minutes later, measure temperature again and check that the temperature does not change.

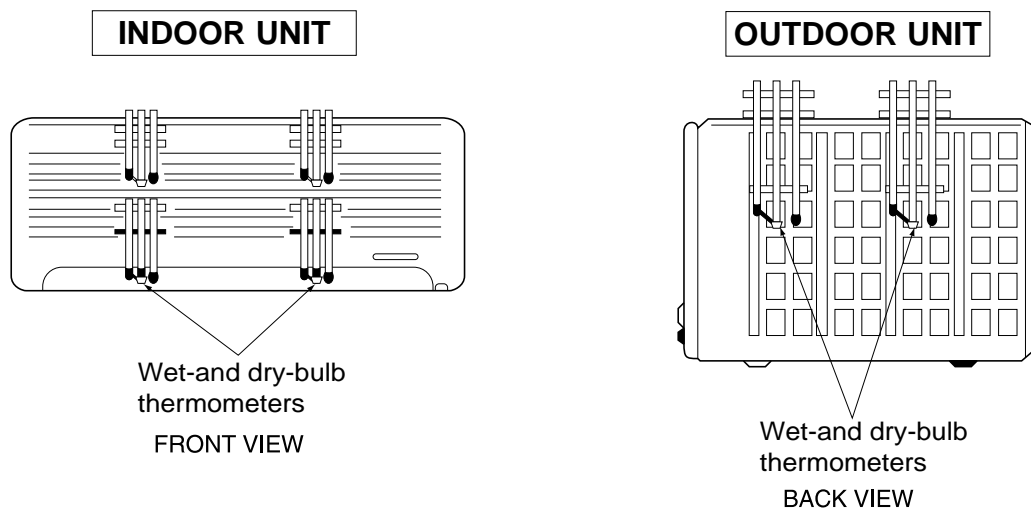

10-1. Capacity and the input curves

MXZ-A14WV-**E1**

MXZ-A18WV-**E1**

8.5	9.3	10.6
7.8	8.5	9.7
7.1	7.8	8.8
6.4	7.0	7.9
5.8	6.3	7.1
5.1	5.6	6.3
07 class	09 class	12 class

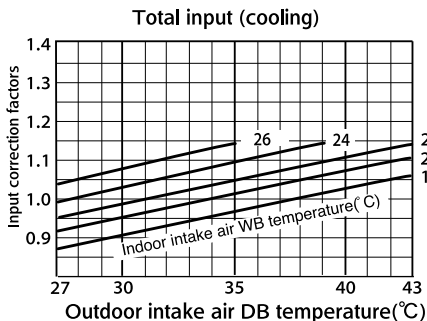
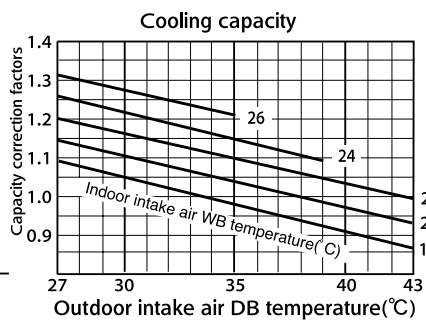

25.4	24.0	25.9
23.4	22.2	23.9
21.5	20.3	21.9
19.5	18.5	19.9
17.6	16.6	17.9
15.6	14.8	15.9
13.7	12.9	13.9
11.7	11.1	12.0
07 class	09 class	12 class

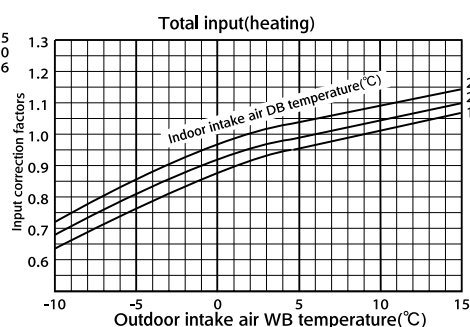
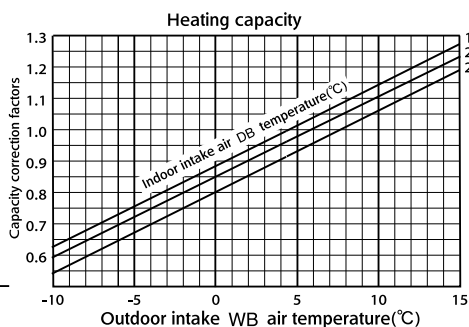

MXZ-A26WV-**E1**

MXZ-A32WV-**E1**

8.5	9.3	10.6	13.1	13.7	17.0
7.8	8.5	9.7	11.9	12.4	15.4
7.1	7.8	8.8	10.8	11.3	13.9
6.4	7.0	7.9	9.7	10.1	12.5
5.8	6.3	7.1	8.7	9.0	11.1
5.1	5.6	6.3	7.7	8.0	9.7
07 class	09 class	12 class	18 class	24 class	26 class

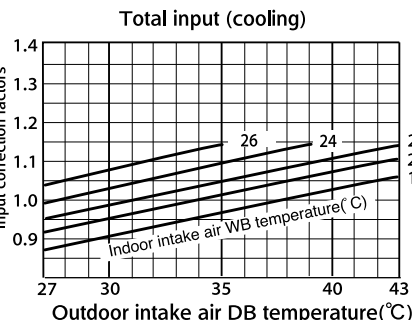
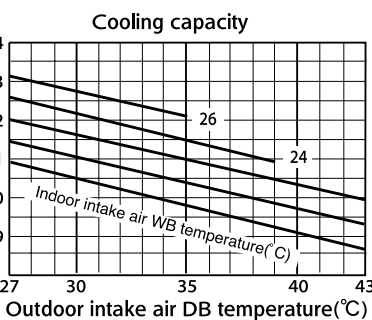

25.4	24.0	25.9	31.4	31.9	35.1
23.4	22.2	23.9	29.0	29.4	32.4
21.5	20.3	21.9	26.6	27.0	29.7
19.5	18.5	19.9	24.1	24.5	27.0
17.6	16.6	17.9	21.7	22.1	24.3
15.6	14.8	15.9	19.3	19.6	21.6
13.7	12.9	13.9	16.9	17.2	18.9
11.7	11.1	12.0	14.5	14.7	16.2
07 class	09 class	12 class	18 class	24 class	26 class

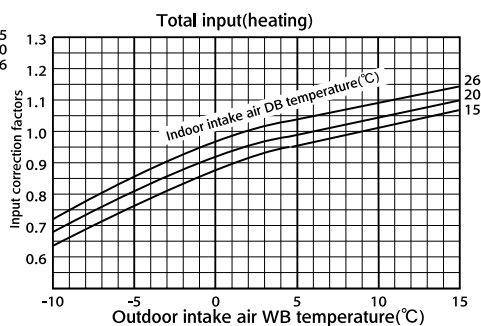
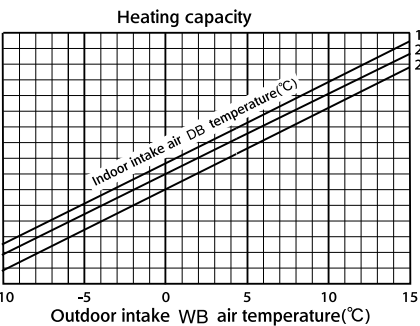

10-2. Capacity and input correction by inverter output frequency (OUTDOOR UNIT : MXZ-A14WV, MXZ-A18WV)

1. 07-class unit in single operation

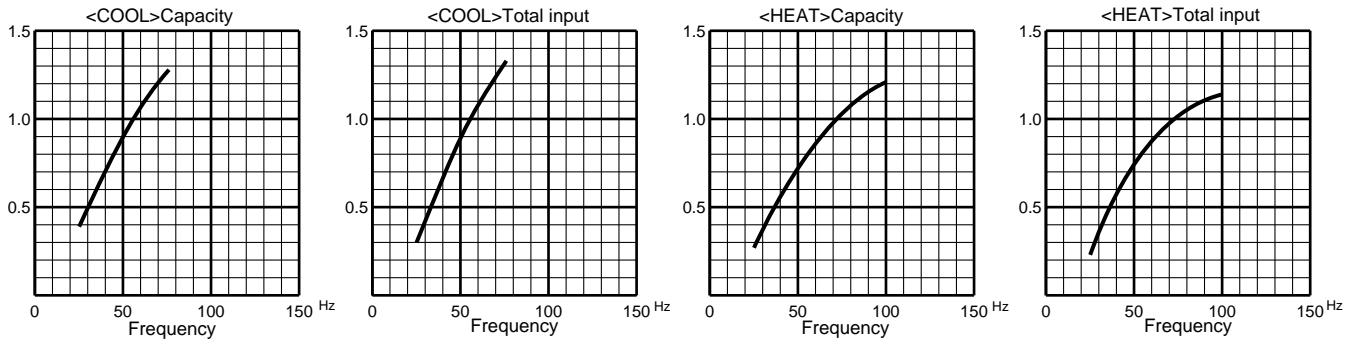

2. 09-class unit in single operation

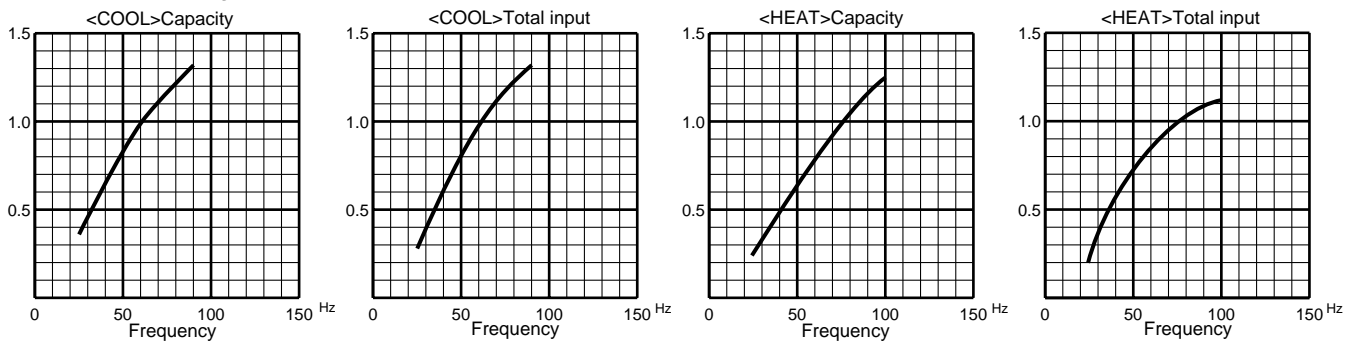

3. 12-class unit in single operation

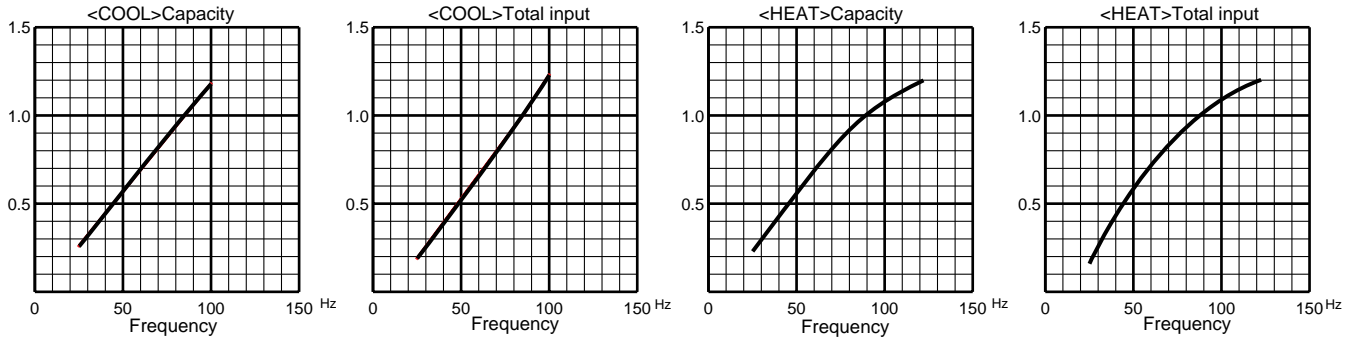

(OUTDOOR UNIT:MXZ-A26WV, MXZ-A32WV)

1. 07-class unit in single operation

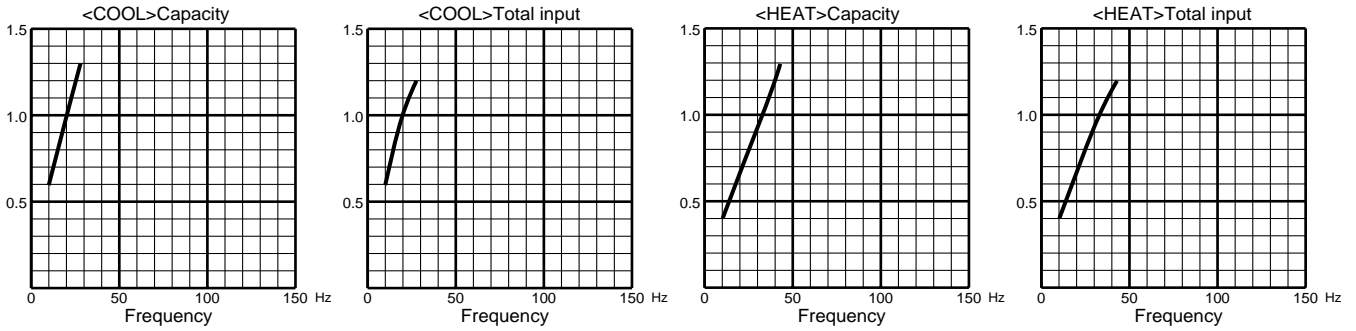

2. 09-class unit in single operation

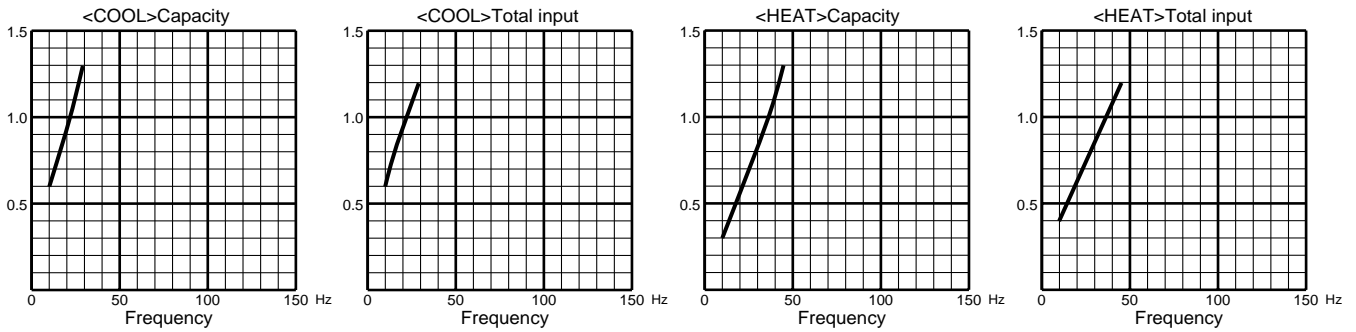

3. 12-class unit in single operation

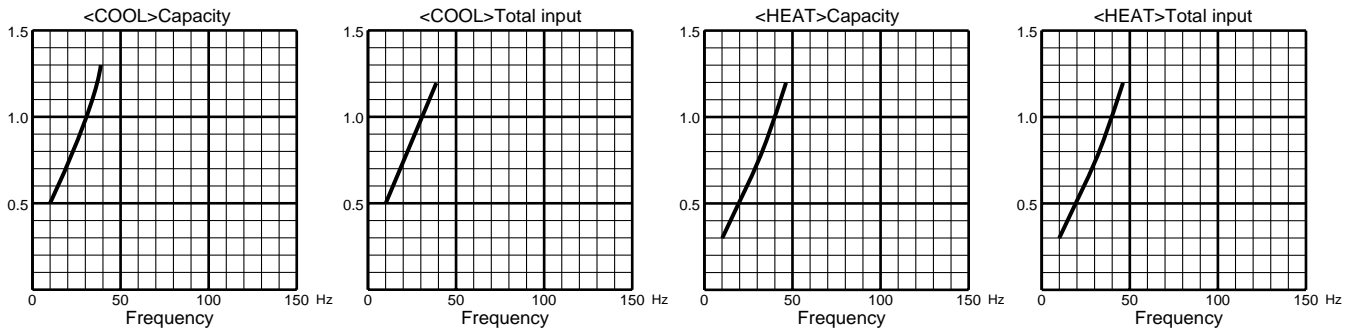

4. 18-class unit in single operation

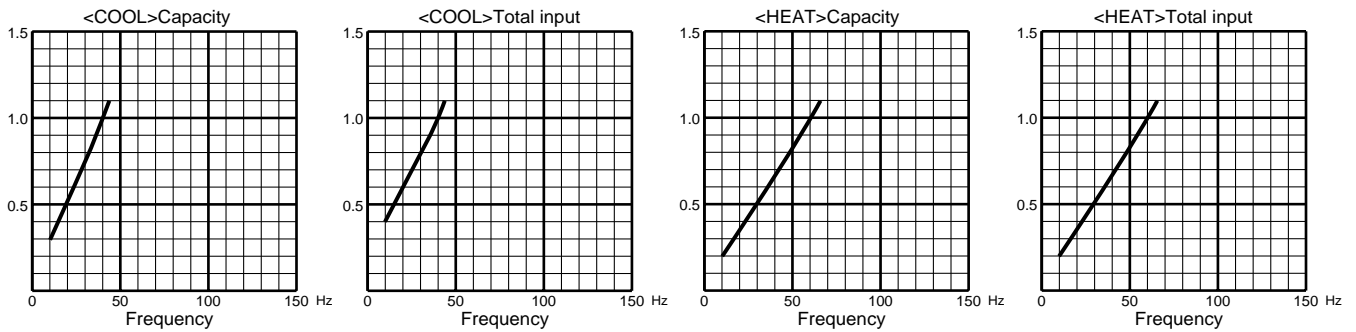

5. 24-class unit in single operation

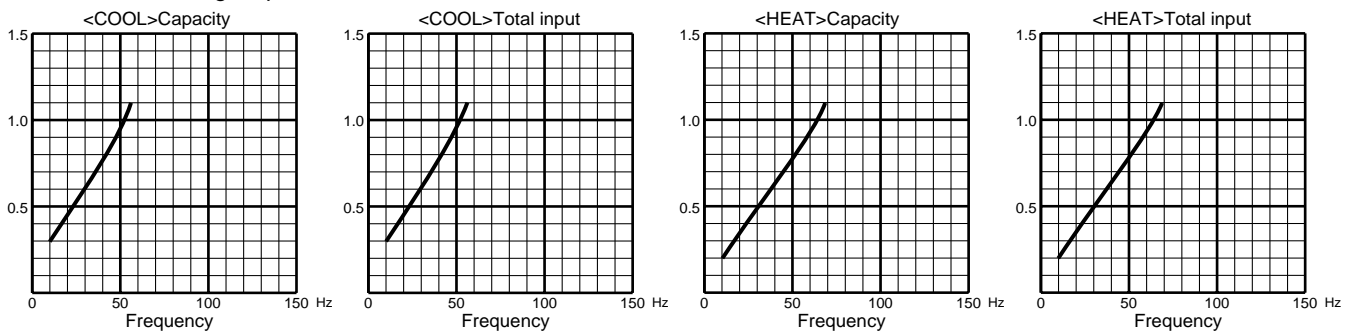

6. 26-class unit in single operation

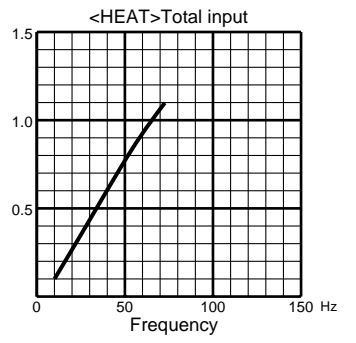
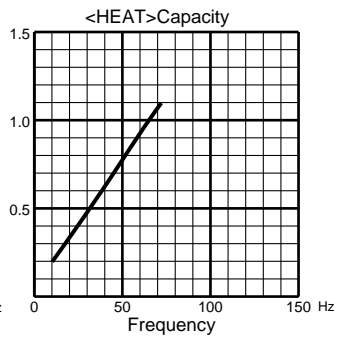
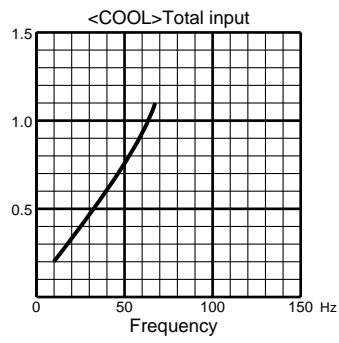
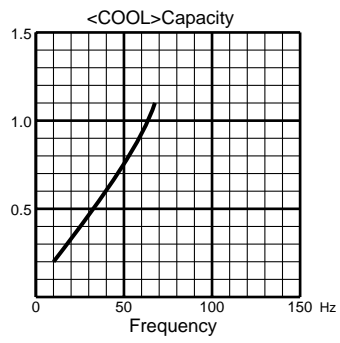

10-3. Outdoor low pressure and outdoor unit current

1. 07-class unit in single operation (OUTDOOR UNIT : MXZ-A14WV, MXZ-A18WV)

NOTE:The unit of pressure has been changed to MPa on the international system of units(SI unit system).

The conversion factor is : 1(MPa[Gauge]) =10.2(kgf/cm²[Gauge])

(1) COOL operation

①Both indoor and outdoor units are under the same temperature/humidity condition.

Dry-bulb temperature(°C)	Relative humidity(%)
20	50
25	60
30	70

②Air flow speed : High

③Inverter output frequency : 33Hz

<How to work fixed-frequency operation>

- 1.Set emergency switch to COOL or HEAT. The switch is located on indoor unit.
- 2.Press emergency operation button.
- 3.Compressor starts running at fixed-frequency.
- 4.Indoor fan runs at High speed and continues for 30 minutes.
- 5.To cancel this operation, press emergency operation button or any button on remote controller.

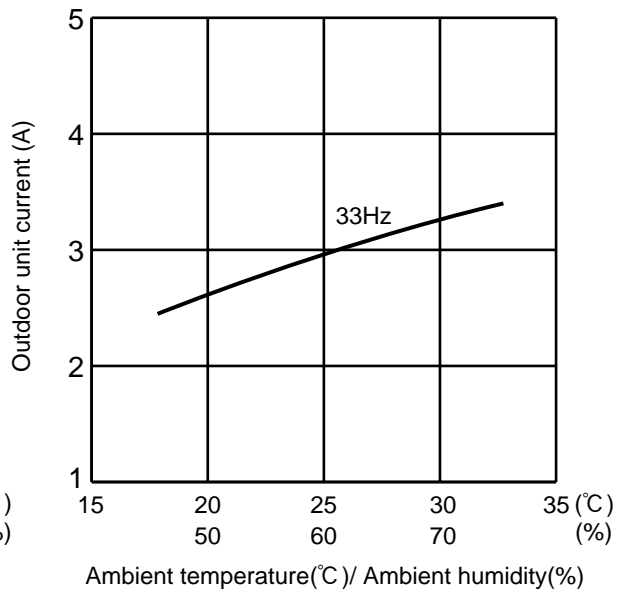
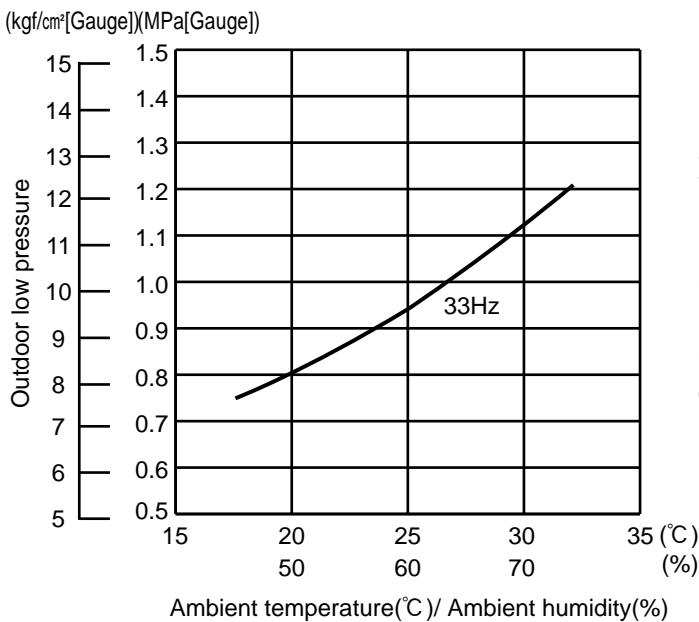

(2) HEAT operation

Indoor	DB(°C)	20.0	Outdoor	DB(°C)	2	7	15	20.0
	WB(°C)	14.5		WB(°C)	1	6	12	14.5

②Set air flow to High speed.

③Inverter output frequency is 45Hz.

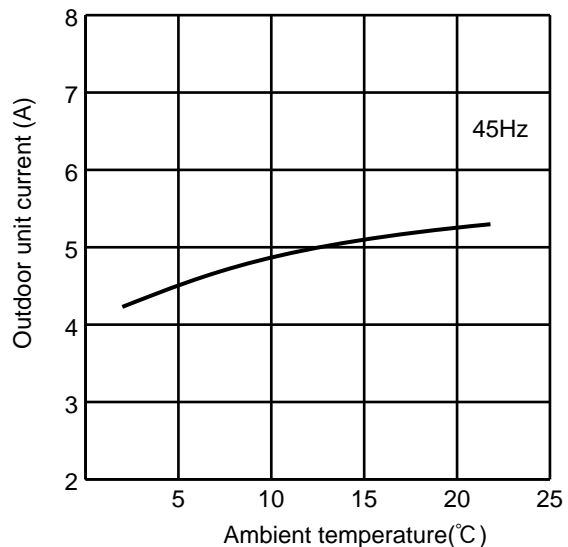

2. 09-class unit in single operation (OUTDOOR UNIT : MXZ-A14WV, MXZ-A18WV)

NOTE: The unit of pressure has been changed to MPa on the international system of units(SI unit system).

The conversion factor is : **1(MPa[Gauge]) =10.2(kgf/cm²[Gauge])**

(1) COOL operation

- ① Both indoor and outdoor units are under the same temperature/humidity condition.

Dry-bulb temperature(°C)	Relative humidity(%)
20	50
25	60
30	70

- ② Air flow speed : High
③ Inverter output frequency : 33Hz

<How to work fixed-frequency operation>

1. Set emergency switch to COOL or HEAT. The switch is located on indoor unit.
2. Press emergency operation button.
3. Compressor starts running at fixed-frequency.
4. Indoor fan runs at High speed and continues for 30 minutes.
5. To cancel this operation, press emergency operation button or any button on remote controller.

(kgf/cm²[Gauge])(MPa[Gauge])

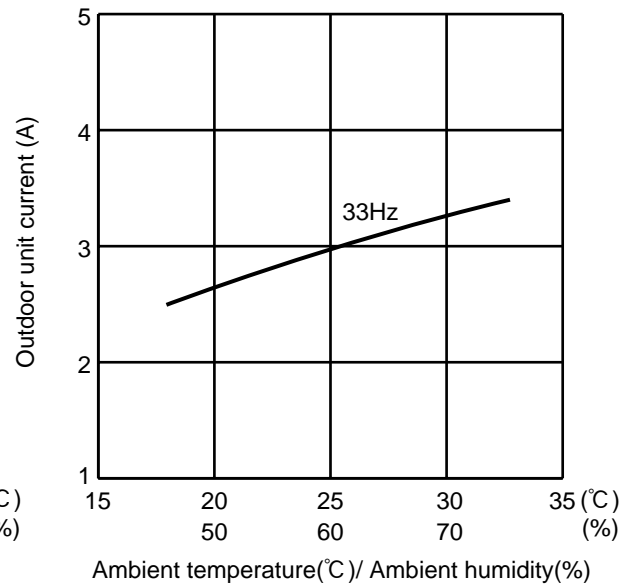
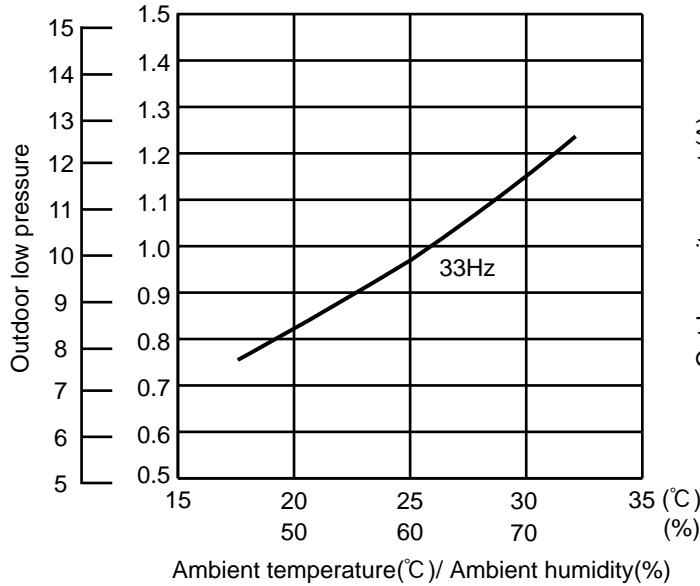

(2) HEAT operation

① Indoor	DB(°C)	20.0	Outdoor	DB(°C)	2	7	15	20.0
	WB(°C)	14.5		WB(°C)	1	6	12	14.5

- ② Set air flow to High speed.
③ Inverter output frequency is 45Hz.

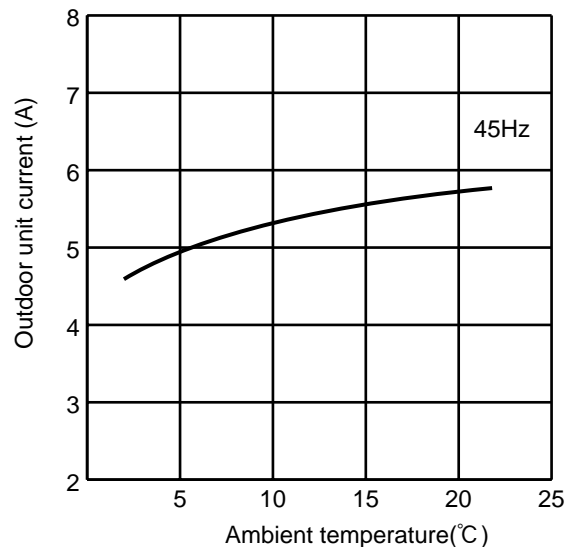

3. 12-class unit in single operation (OUTDOOR UNIT : MXZ-A14WV, MXZ-A18WV)

NOTE: The unit of pressure has been changed to MPa on the international system of units(SI unit system).

The conversion factor is : **1(MPa[Gauge]) =10.2(kgf/cm²[Gauge])**

(1) COOL operation

①Both indoor and outdoor units are under the same temperature/humidity condition.

Dry-bulb temperature(°C)	Relative humidity(%)
20	50
25	60
30	70

②Air flow speed : High

③Inverter output frequency : 33Hz

<How to work fixed-frequency operation>

- 1.Set emergency switch to COOL or HEAT. The switch is located on indoor unit.
- 2.Press emergency operation button.
- 3.Compressor starts running at fixed-frequency.
- 4.Indoor fan runs at High speed and continues for 30 minutes.
- 5.To cancel this operation, press emergency operation button or any button on remote controller.

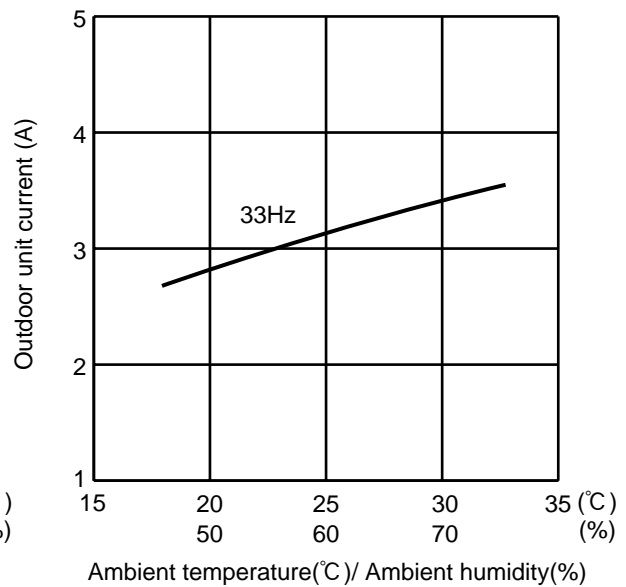
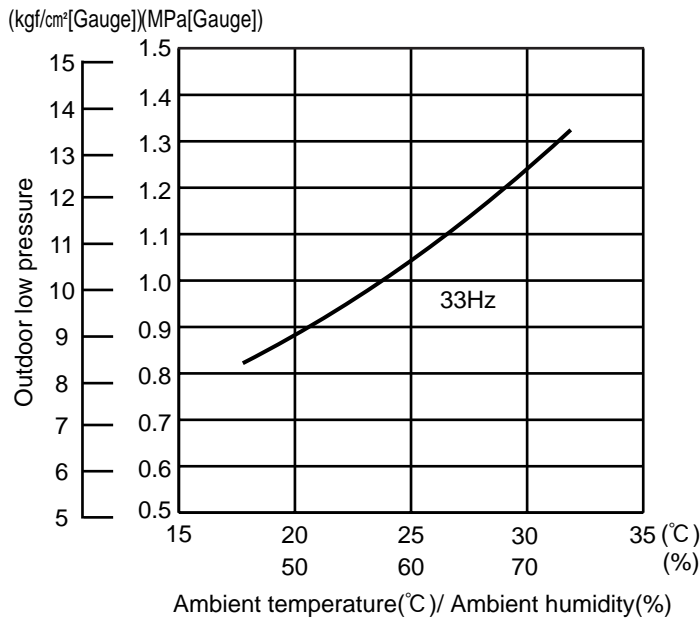

(2) HEAT operation

Indoor	DB(°C)	20.0	Outdoor	DB(°C)	2	7	15	20.0
	WB(°C)	14.5		WB(°C)	1	6	12	14.5

②Set air flow to High speed.

③Inverter output frequency is 45Hz.

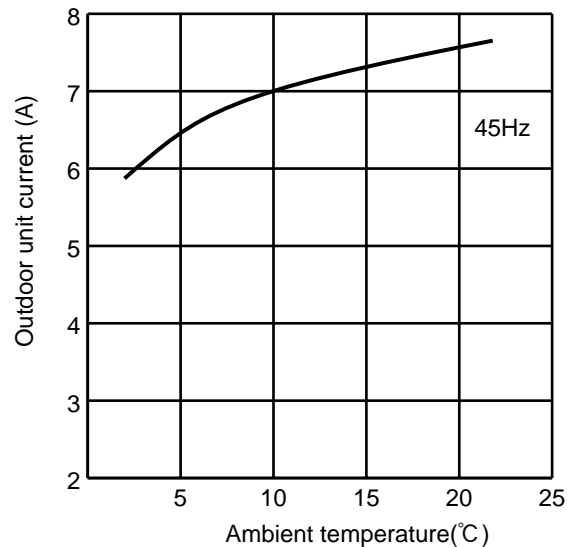

4. 07-class unit in single operation (OUTDOOR UNIT : MXZ-A26WV, MXZ-A32WV)

NOTE:The unit of pressure has been changed to MPa on the international system of units(SI unit system).

The conversion factor is : $1(\text{MPa}[\text{Gauge}]) = 10.2(\text{kgf}/\text{cm}^2[\text{Gauge}])$

(1) COOL operation

①Both indoor and outdoor units are under the same temperature/humidity condition.

Dry-bulb temperature(°C)	Relative humidity(%)
20	50
25	60
30	70

②Air flow speed : High

③Inverter output frequency : 24Hz

<How to work fixed-frequency operation>

- 1.Set emergency switch to COOL or HEAT. The switch is located on indoor unit.
- 2.Press emergency operation button.
- 3.Compressor starts running at fixed-frequency.
- 4.Indoor fan runs at High speed and continues for 30 minutes.
- 5.To cancel this operation, press emergency operation button or any button on remote controller.

(kgf/cm²[Gauge])(MPa[Gauge])

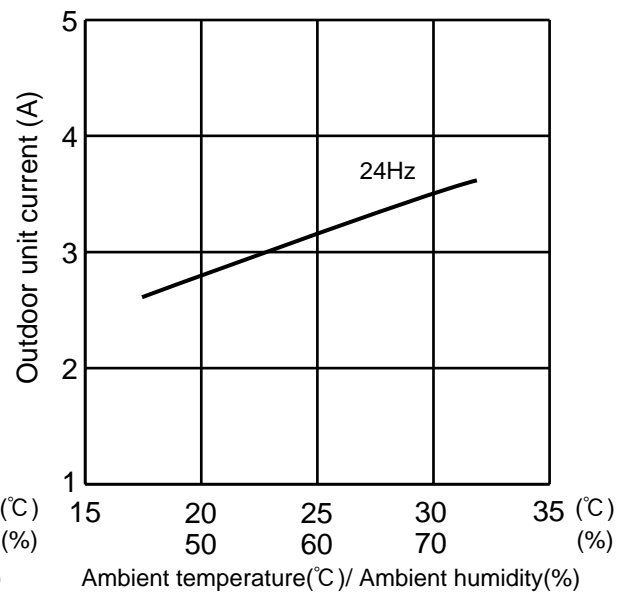
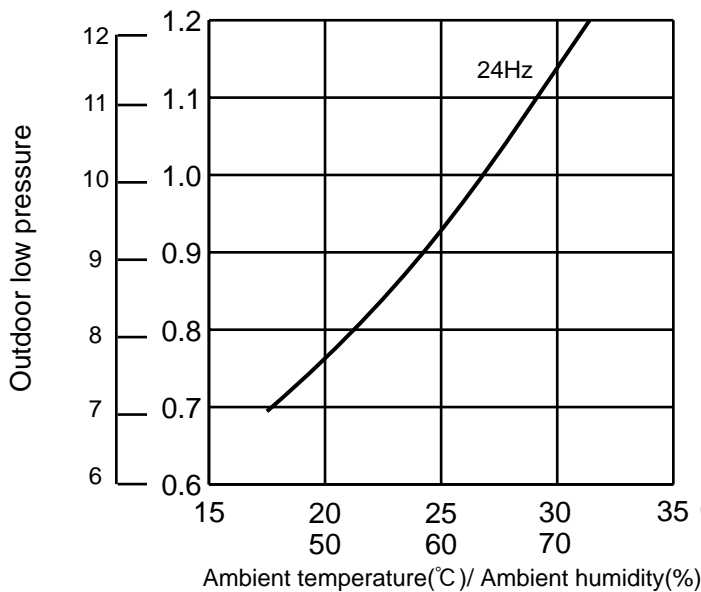

(2) HEAT operation

①Indoor	DB(°C)	20.0	Outdoor	DB(°C)	2	7	15	20.0
	WB(°C)	14.5		WB(°C)	1	6	12	14.5

②Set air flow to High speed.

③Inverter output frequency is 32Hz.

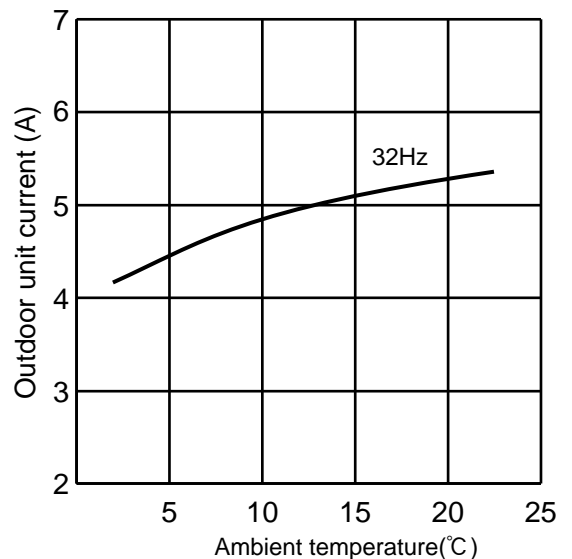

5. 09-class unit in single operation (OUTDOOR UNIT : MXZ-A26WV, MXZ-A32WV)

NOTE:The unit of pressure has been changed to MPa on the international system of units(SI unit system).

The conversion factor is : **1(MPa[Gauge]) =10.2(kgf/cm²[Gauge])**

(1) COOL operation

- ①Both indoor and outdoor units are under the same temperature/humidity condition.

Dry-bulb temperature(°C)	Relative humidity(%)
20	50
25	60
30	70

②Air flow speed : High

③Inverter output frequency : 24Hz

<How to work fixed-frequency operation>

- 1.Set emergency switch to COOL or HEAT. The switch is located on indoor unit.
- 2.Press emergency operation button.
- 3.Compressor starts running at fixed-frequency.
- 4.Indoor fan runs at High speed and continues for 30 minutes.
- 5.To cancel this operation, press emergency operation button or any button on remote controller.

(kgf/cm²[Gauge])(MPa[Gauge])

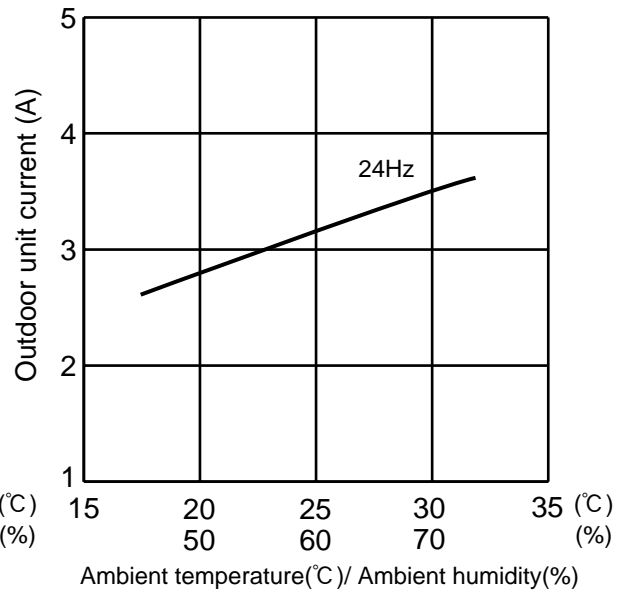
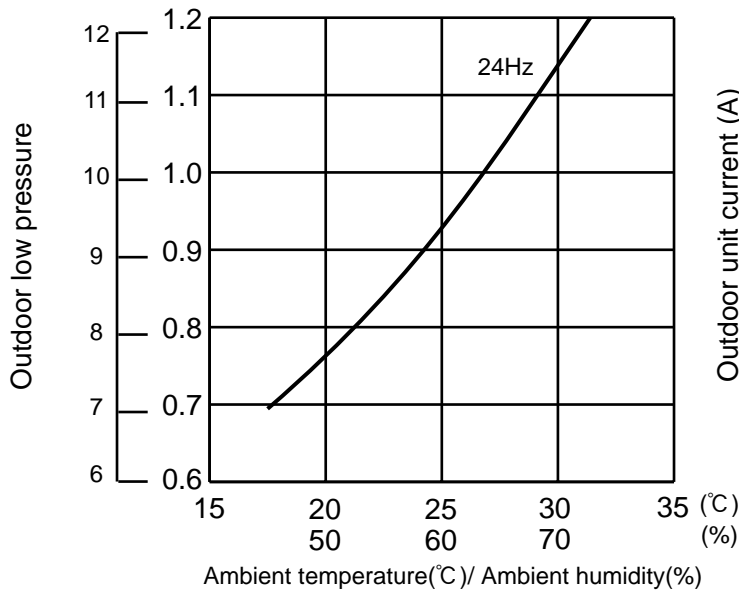

(2) HEAT operation

①Indoor	DB(°C)	20.0	Outdoor	DB(°C)	2	7	15	20.0
	WB(°C)	14.5		WB(°C)	1	6	12	14.5

②Set air flow to High speed.

③Inverter output frequency is 32Hz.

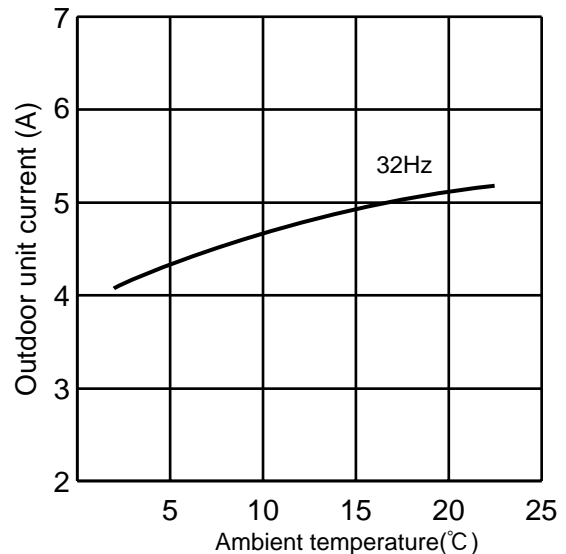

6. 12-class unit in single operation (OUTDOOR UNIT : MXZ-A26WV, MXZ-A32WV)

NOTE:The unit of pressure has been changed to MPa on the international system of units(SI unit system).

The conversion factor is : $1(\text{MPa[Gauge]}) = 10.2(\text{kgf/cm}^2[\text{Gauge}])$

(1) COOL operation

- ①Both indoor and outdoor units are under the same temperature/humidity condition.

Dry-bulb temperature(°C)	Relative humidity(%)
20	50
25	60
30	70

- ②Air flow speed : High

- ③Inverter output frequency : 24Hz

<How to work fixed-frequency operation>

- 1.Set emergency switch to COOL or HEAT. The switch is located on indoor unit.
- 2.Press emergency operation button.
- 3.Compressor starts running at fixed-frequency.
- 4.Indoor fan runs at High speed and continues for 30 minutes.
- 5.To cancel this operation, press emergency operation button or any button on remote controller.

(kgf/cm²[Gauge])(MPa[Gauge])

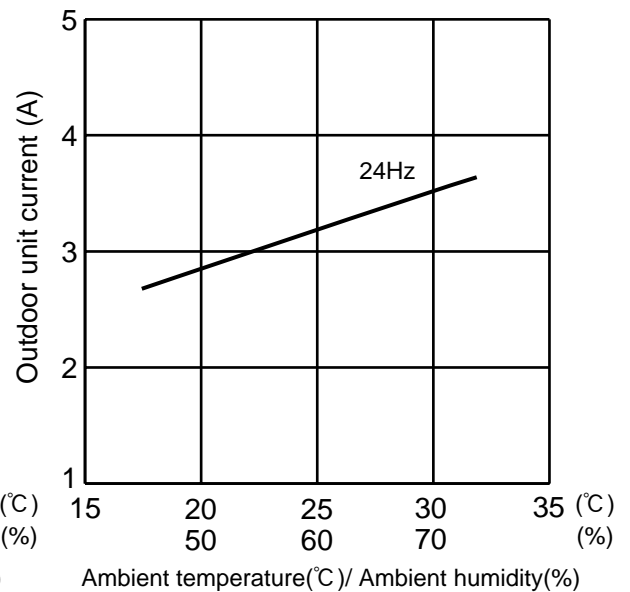
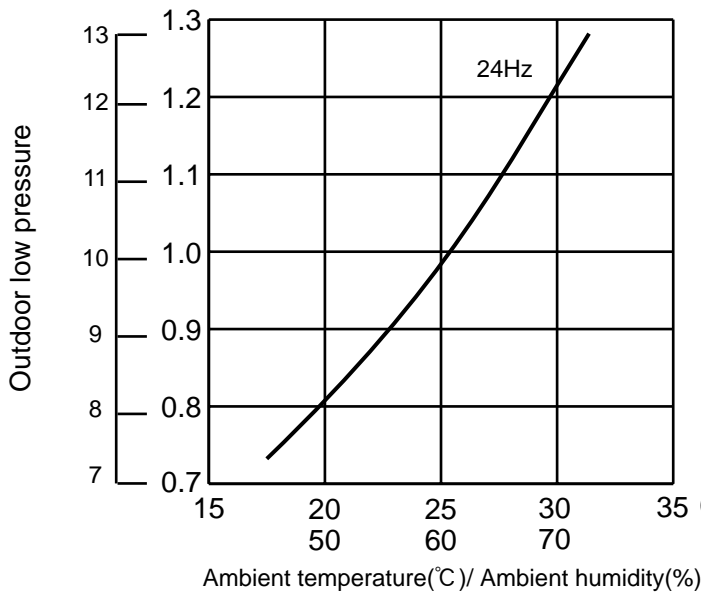

(2) HEAT operation

①Indoor	DB(°C)	20.0	Outdoor	DB(°C)	2	7	15	20.0
	WB(°C)	14.5		WB(°C)	1	6	12	14.5

- ②Set air flow to High speed.

- ③Inverter output frequency is 32Hz.

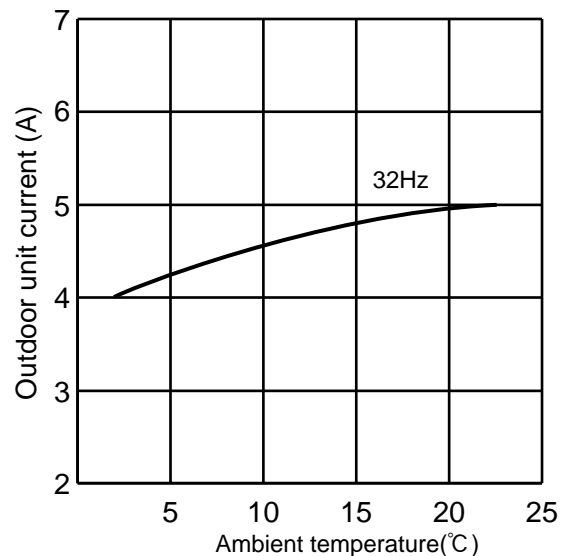

7. 18-class unit in single operation (OUTDOOR UNIT : MXZ-A26WV, MXZ-A32WV)

NOTE:The unit of pressure has been changed to MPa on the international system of units(SI unit system).

The conversion factor is : **1(MPa[Gauge]) =10.2(kgf/cm²[Gauge])**

(1) COOL operation

- ①Both indoor and outdoor units are under the same temperature/humidity condition.

Dry-bulb temperature(°C)	Relative humidity(%)
20	50
25	60
30	70

- ②Air flow speed : High

- ③Inverter output frequency : 24Hz

<How to work fixed-frequency operation>

- 1.Set emergency switch to COOL or HEAT. The switch is located on indoor unit.
- 2.Press emergency operation button.
- 3.Compressor starts running at fixed-frequency.
- 4.Indoor fan runs at High speed.
- 5.To cancel this operation, press emergency operation button or any button on remote controller.

(kgf/cm²[Gauge])(MPa[Gauge])

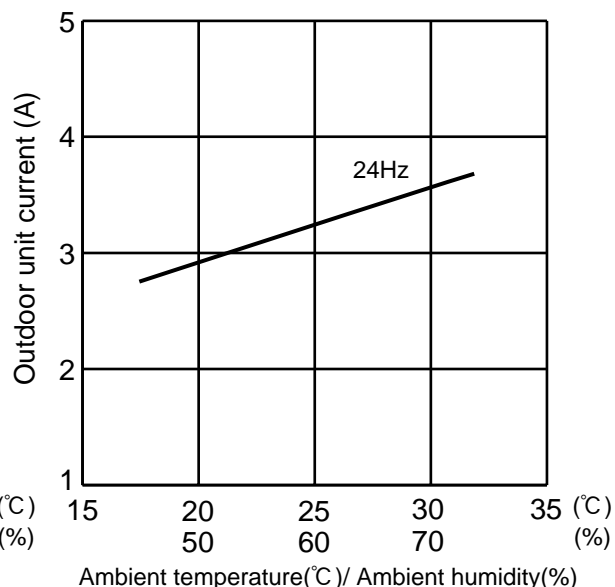
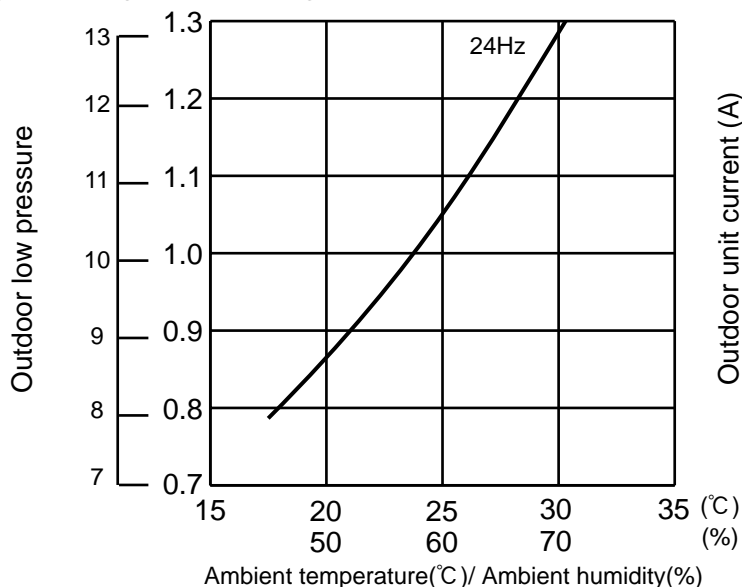

(2) HEAT operation

Indoor	DB(°C)	20.0	Outdoor				
	WB(°C)	14.5	DB(°C)	2	7	15	20.0
			WB(°C)	1	6	12	14.5

- ②Set air flow to High speed.

- ③Inverter output frequency is 32Hz.

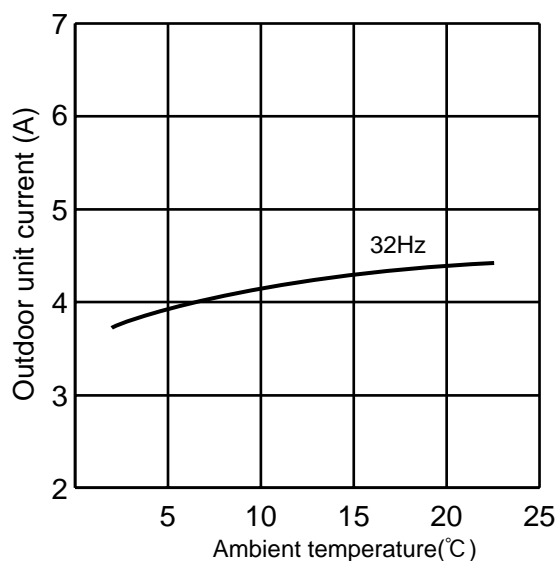

8. 24-class unit in single operation (OUTDOOR UNIT : MXZ-A26WV, MXZ-A32WV)

NOTE:The unit of pressure has been changed to MPa on the international system of units(SI unit system).

The conversion factor is : **1(MPa[Gauge]) =10.2(kgf/cm²[Gauge])**

(1) COOL operation

- ①Both indoor and outdoor units are under the same temperature/humidity condition.

Dry-bulb temperature(°C)	Relative humidity(%)
20	50
25	60
30	70

- ②Air flow speed : High
③Inverter output frequency : 24Hz

<How to work fixed-frequency operation>

- 1.Set emergency switch to COOL or HEAT. The switch is located on indoor unit.
- 2.Press emergency operation button.
- 3.Compressor starts running at fixed-frequency.
- 4.Indoor fan runs at High speed.
- 5.To cancel this operation, press emergency operation button or any button on remote controller.

(kgf/cm²[Gauge])(MPa[Gauge])

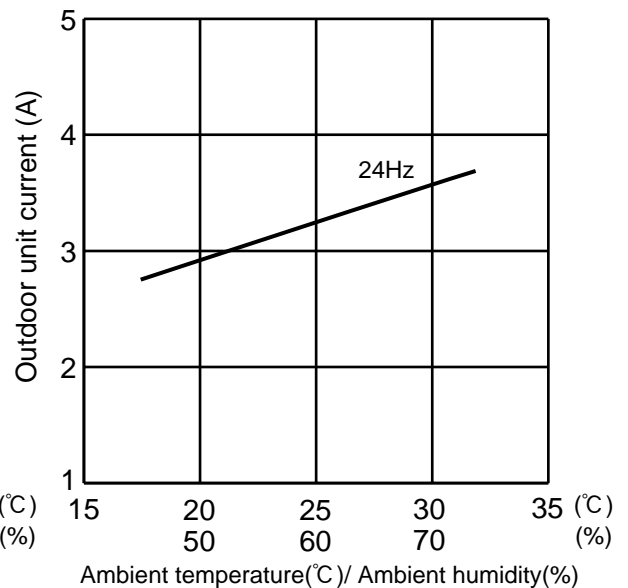
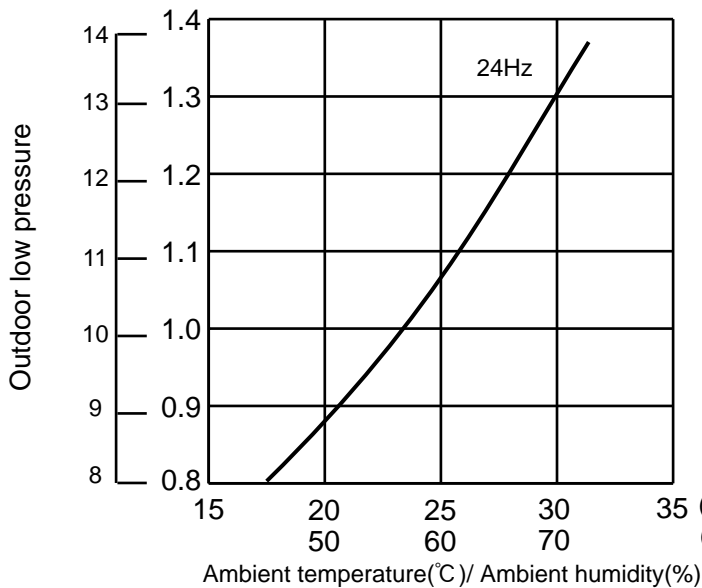

(2) HEAT operation

Indoor	DB(°C)	20.0	Outdoor	DB(°C)	2	7	15	20.0
	WB(°C)	14.5		WB(°C)	1	6	12	14.5

- ②Set air flow to High speed.
③Inverter output frequency is 32Hz.

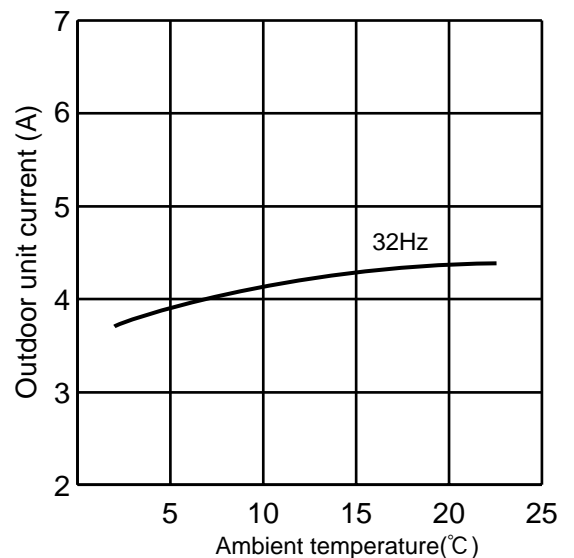

9. 26-class unit in single operation (OUTDOOR UNIT : MXZ-A26WV, MXZ-A32WV)

NOTE:The unit of pressure has been changed to MPa on the international system of units(SI unit system).

The conversion factor is : **1(MPa[Gauge]) =10.2(kgf/cm²[Gauge])**

(1) COOL operation

- ①Both indoor and outdoor units are under the same temperature/humidity condition.

Dry-bulb temperature(°C)	Relative humidity(%)
20	50
25	60
30	70

- ②Air flow speed : High

- ③Inverter output frequency : 24Hz

<How to work fixed-frequency operation>

- 1.Set emergency switch to COOL or HEAT. The switch is located on indoor unit.
- 2.Press emergency operation button.
- 3.Compressor starts running at fixed-frequency.
- 4.Indoor fan runs at High speed.
- 5.To cancel this operation, press emergency operation button or any button on remote controller.

(kgf/cm²[Gauge])(MPa[Gauge])

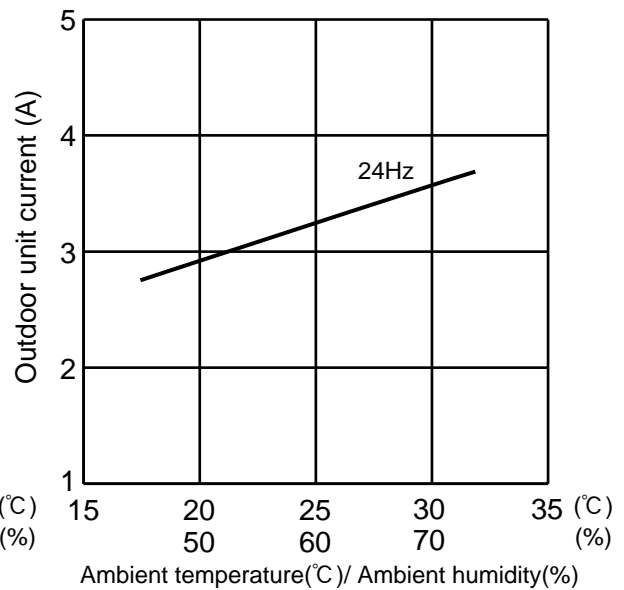
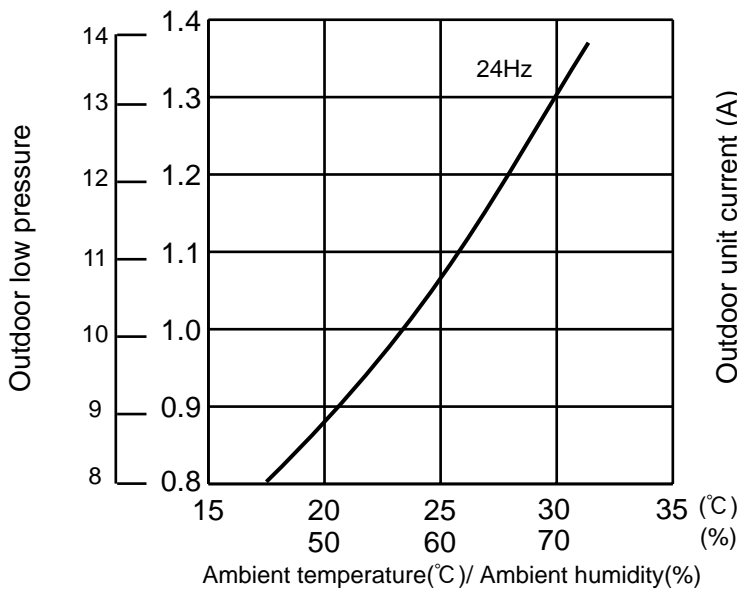

(2) HEAT operation

①Indoor	DB(°C)	20.0	Outdoor	DB(°C)	2	7	15	20.0
	WB(°C)	14.5		WB(°C)	1	6	12	14.5

- ②Set air flow to High speed.

- ③Inverter output frequency is 32Hz.

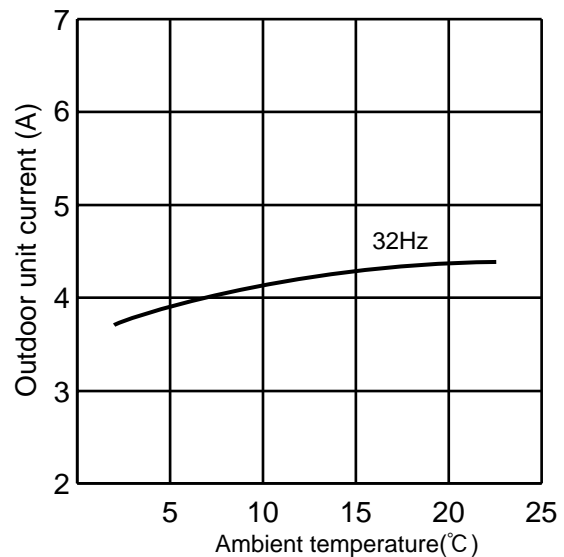

11-1. INVERTER MULTI SYSTEM CONTROL

MXZ-A14WV -E1

MXZ-A18WV -E1

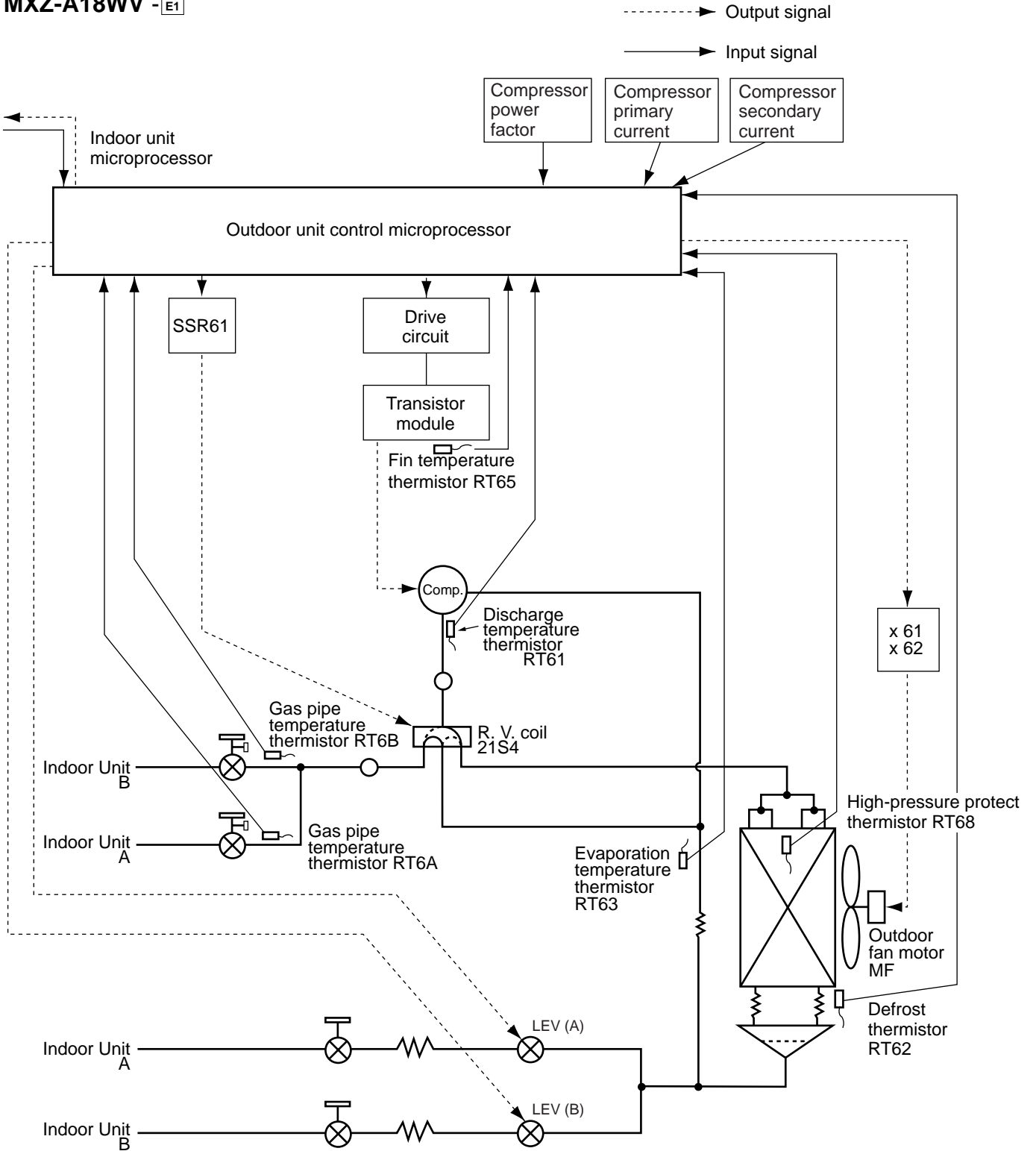

MXZ-A26WV - [E1]

-----> Output signal
 ———> Input signal

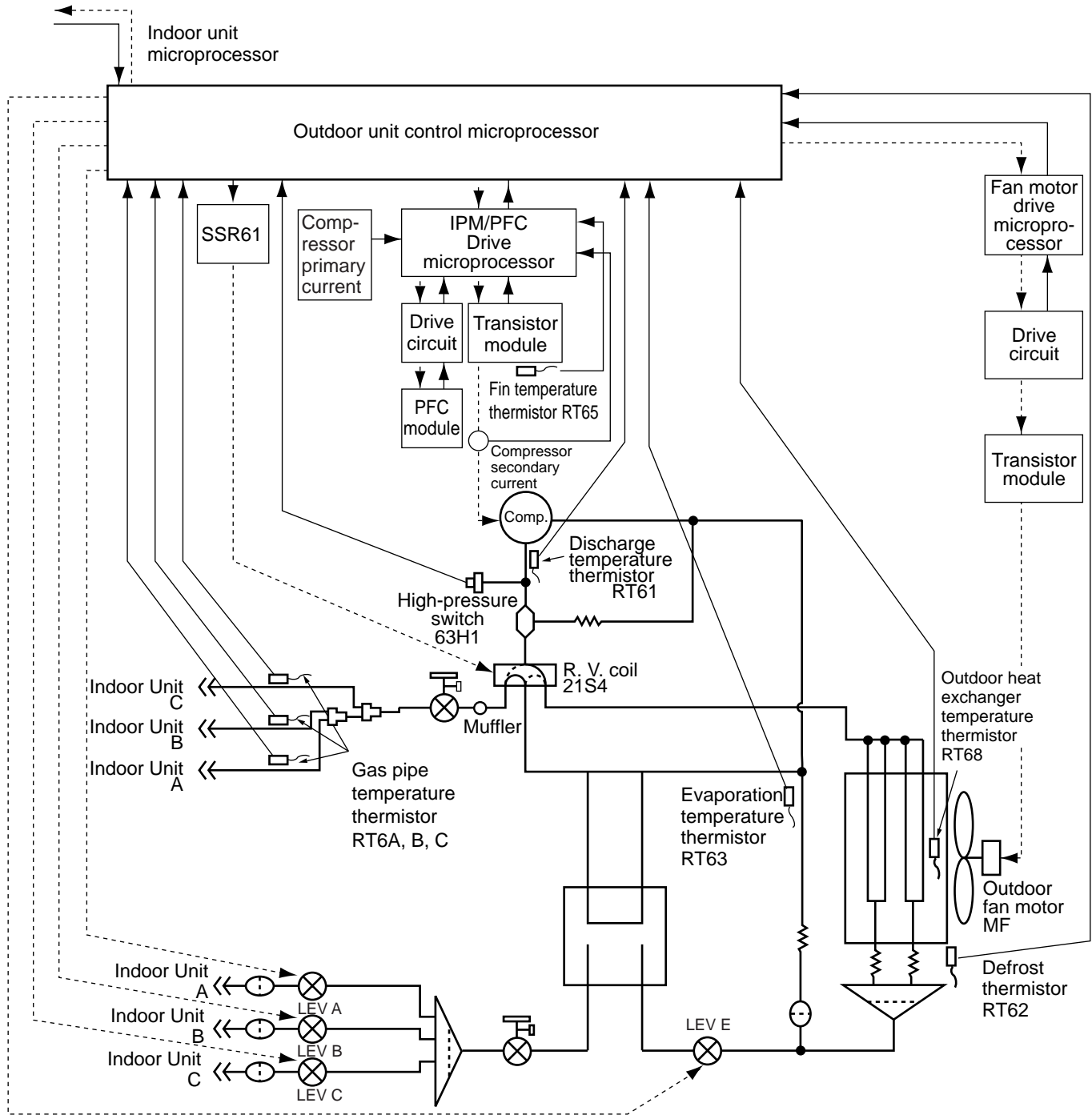

MXZ-A32WV -E1

-----> Output signal
 —————> Input signal

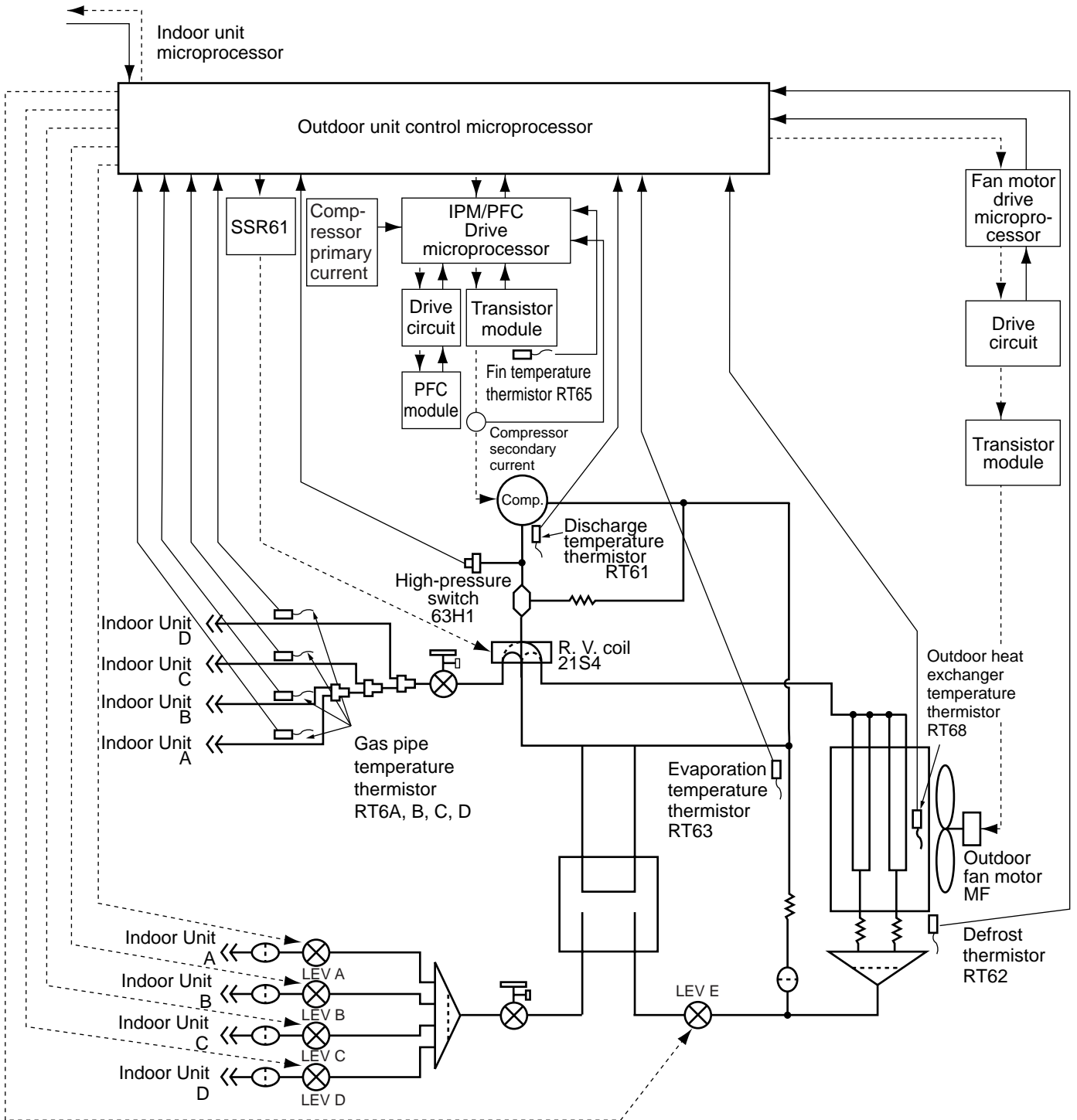

11-2.HEAT DEFROSTING CONTROL

(1) Conditions to enter defrosting mode

- ①. When temperature of defrosting thermistor is -3°C or less.
- ②. When specified non-defrosting time, is counted in the control p.c.board is satisfied.
(Total time of compressor operating)

Going to defrosting mode at both condition of ① and ②.

(2) Defrosting operation

- ①. Compressor stops for 50 seconds, Indoor fan is off, Defrosting lamp lights.
- ②. 4-way valve reverses flow, Compressor operates by the frequency in heat defrosting control.
- ③. After compressor stops for 35 seconds, 4-way valve reverses flow, then defrosting finishes.

(3) Conditions to finish defrosting mode

- ①. When the defrosting thermistor temperature is 13.2°C or more.
- ②. When it has spent 10 minutes for defrosting.

Defrosting finishes at condition of ① or ②.

11-3.DISCHARGE TEMPERATURE PROTECTION CONTROL

This protection controls the compressor ON/OFF and operation frequency according to temperature of the discharge temperature thermistor.

(1) Compressor ON/OFF

When temperature of the discharge temperature thermistor exceeds 116°C , the control stops the compressor.

When temperature of the discharge temperature thermistor is 80°C or less, the controls starts the compressor.

(2) Compressor operation frequency

When temperature of the discharge temperature thermistor is expected to be higher than 116°C , the control decreases 12Hz from the current frequency.

When temperature of the discharge temperature thermistor is expected to be higher than 111°C and less than 116°C , the control decreases 6Hz from the current frequency.

When temperature of the discharge temperature thermistor is expected to be higher than 104°C and less than 111°C , the control is set at the current frequency.

11-4.REFRIGERANT RECOVERY CONTROL ON HEATING

<Control status>

The control performs when the all the following status are satisfied;

- When one or more indoor units are operating in HEAT mode. (Excluding thermostat OFF)
- When discharge temperature becomes 107°C or more.
- When it passed 60 minutes or more since the operation has started or the last refrigerant recovery has controlled.

<Control details>

LEV opening of indoor unit not operating is controlled to be 80 pulse.

<Control finish status>

The control finishes either as follows. However, the LEV opening is considered to be 59 pulse.

- When it passed 60 seconds since the control has started.
- When the discharge temperature is 90°C or less.

11-5.OUTDOOR FAN CONTROL

Fan speed is switched according to the number of operating indoor unit and the compressor frequency.

Fan speed

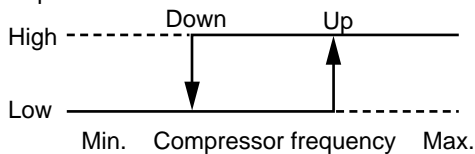

<Relation between compressor frequency and fan speed.>

MXZ-A14WV, MXZ-A18WV

Mode	Fan speed	Indoor unit operation	
		1 unit	2 units
COOL	Up	60Hz	60Hz
	Down	50Hz	50Hz
HEAT	Up	60Hz	60Hz
	Down	50Hz	50Hz

MXZ-A26WV, MXZ-A32WV

Mode	Fan speed	Indoor unit operation		
		1 unit	2 units	3, 4 units
COOL	Up	45Hz	50Hz	55Hz
	Down	35Hz	40Hz	45Hz
HEAT	Up	50Hz	55Hz	60Hz
	Down	40Hz	45Hz	50Hz

Note

- When the indoor coil thermistor is 57°C or more on HEAT operation, fan speed is fixed to Low speed.
Or, the indoor coil thermistor is 45°C or less on HEAT operation, fan speed is back to normal.

11-6.LOW OUTSIDE TEMPERATURE OPERATION

Unlike the usual fan control, the number of rotation is controlled to let the temperature of the outdoor heat exchanger become around 40°C when the unit is operating in COOL mode at low outside temperature.

<Details of Fan Control>

- (a) The number of rotation will be increased when the temperature of the outdoor heat exchanger is high.
- (b) The number of rotation will be decreased when the temperature of the outdoor heat exchanger is low.

The number of rotation will be lowered to around 100 rpm (rotation per minute) when just a few indoor units are operating or when the outside temperature is low.

When the number of rotation is lowered to around 100 rpm, the fan may stop by the influence of wind, but restarts 30 seconds later.

11-7.RELATION BETWEEN MAIN SENSOR AND ACTUATOR

Relation between main sensor and actuator.

MXZ-A14WV, MXZ-A18WV

Sensor	Purpose	Actuator			
		Compressor	LEV	Outdoor fan motor	Reversing valve
Discharge temperature thermistor	Protection	○	○		
Indoor pipe temperature thermistor	Defrosting Protection	○	○	○	
Defrost thermistor	Defrosting	○	○		○
Evaporation temperature thermistor	Control		○		
Gas pipe temperature thermistor	Control		○		
Fin temperature thermistor	Protection	○		○	
High-pressure protect thermistor	Protection	○			
Capacity code	Control	○	○	○	

MXZ-A26WV, MXZ-A32WV

Sensor	Purpose	Actuator			
		Compressor	LEV	Outdoor fan motor	Reversing valve
Discharge temperature thermistor	Protection	○	○		
Indoor pipe temperature thermistor	Defrosting Protection	○	○	○	
Defrost thermistor	Defrosting	○	○	○	○
Evaporation temperature thermistor	Control		○		
Gas pipe temperature thermistor	Control		○		
Fin temperature thermistor	Protection	○		○	
Outdoor heat exchanger temperature	Protection	○	○	○	
Capacity code	Control	○	○		

MXZ-A14WV-E1MXZ-A18WV-E1MXZ-A26WV-E1MXZ-A32WV-E1**12-1. Cautions on troubleshooting****1. Before troubleshooting, check the following:**

- 1) Check the power supply voltage.
- 2) Check the indoor/outdoor connecting wire for mis-wiring.

2. Take care the following during servicing.

- 1) Before servicing the air conditioner, be sure to first turn off the remote controller to stop the unit, and then after confirming the horizontal vane is closed, turn off the breaker and/or disconnect the power plug.
- 2) Be sure to turn OFF the power supply before removing the front panel, the cabinet, the top panel, and the electronic control P.C. board.
- 3) When removing the electrical parts, be careful to the residual voltage of smoothing capacitor.
- 4) When removing the electronic control P.C. board, hold the edge of the board with care NOT to apply stress on the components.
- 5) When connecting or disconnecting the connectors, hold the housing of the connector. DO NOT pull the lead wires.

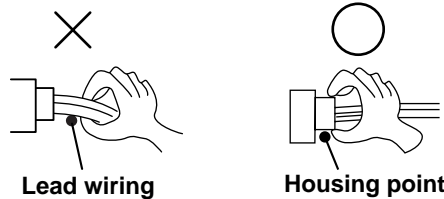
**3. Troubleshooting procedure**

- 1) First, check if the OPERATION INDICATOR lamp on the indoor unit is flashing on and off to indicate an abnormality. To make sure, check how many times the abnormality indication is flashing on and off before starting service work.
- 2) If the electronic control P.C. board is supposed to be defective, check the copper foil pattern for disconnection and the components for bursting and discoloration.
- 3) When troubleshooting, refer to 12-2. and 12-3..

12-2. Instruction of troubleshooting

- Check the indoor unit with referring to the indoor unit service manual, and confirm that there is any problem in the indoor unit.
- Then, check the outdoor unit with referring to this page.

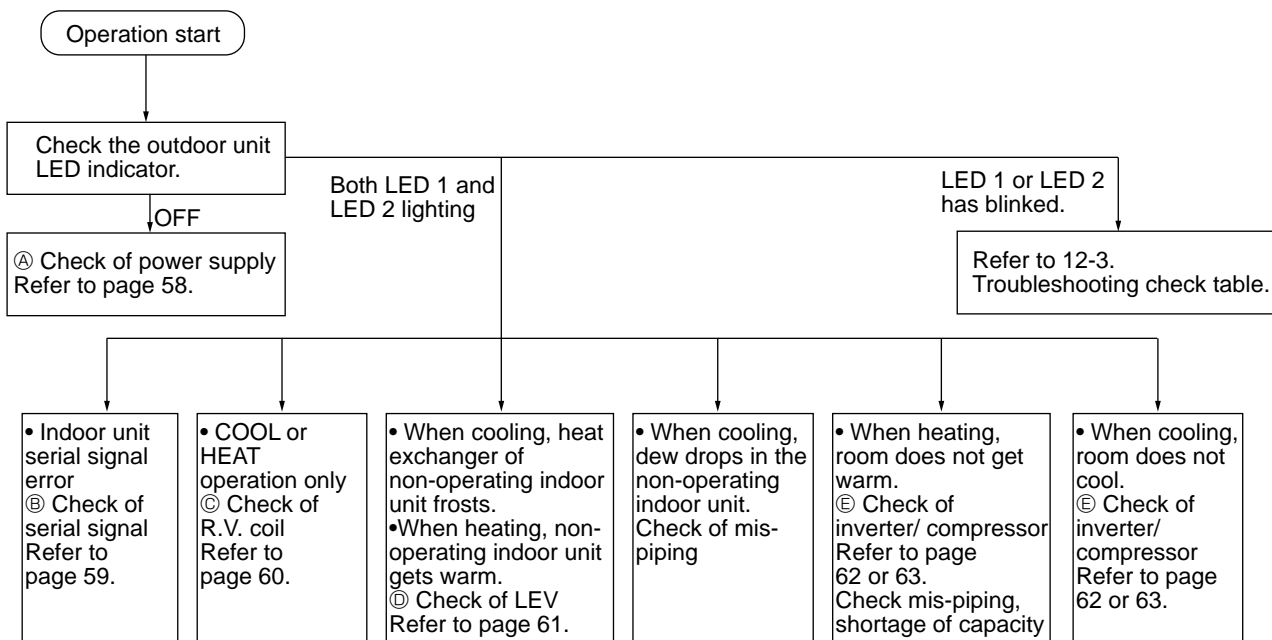
MXZ-A14WV -E1MXZ-A18WV -E1MXZ-A26WV -E1MXZ-A32WV -E1

12-3. Troubleshooting check table

MXZ-A14WV - [E1]

MXZ-A18WV - [E1]

LED 1 (Red)	LED 2 (Yellow)	Error mode
Lighting	Lighting	Normal

Symptom: Outdoor unit does not operate.				
Indication		Abnormal point	Detecting method	Check points
LED 1 (Red)	LED 2 (Yellow)			
Lighting	Once	Indoor unit and LEV	When the drain abnormality is detected in the indoor unit and the indoor unit coil temperature is too low, or when any abnormality is detected in the components of indoor unit.	<ul style="list-style-type: none"> Check the abnormality indication on the indoor unit. Check the LEV.
Lighting	Twice	Outdoor power system	When the compressor operation has been interrupted by over current protection continuously three times within 1 minute after start-up.	<ul style="list-style-type: none"> Check the inverter/compressor.
Lighting	7 times	Outdoor control system	When the nonvolatile memory data cannot be read properly on the outdoor electronic control P.C. board.	<ul style="list-style-type: none"> Replace the outdoor electronic control P.C. board.
Lighting	8 times	Active filter module	When active filter module self-protection has been performed continuously three times.	<ul style="list-style-type: none"> Replace the outdoor electronic control P.C. board.
Lighting	9 times	DC voltage sensing circuit	When DC voltage sensing circuit detects 57V or below or 395V or above.	<ul style="list-style-type: none"> Replace the outdoor electronic control P.C. board.

Symptom: It is repeated that outdoor unit stops and restarts 3 minutes later.				
Indication		Abnormal point	Detecting method	Check points
LED 1 (Red)	LED 2 (Yellow)			
Lighting	3 times	Discharge temperature thermistor	When a short or open circuit occurs in the discharge temperature thermistor during compressor operating.	<ul style="list-style-type: none"> Check the characteristic of the discharge temperature thermistor. Check the connector. (CN662)
Lighting	4 times	Fin temperature thermistor	When a short or open circuit occurs in the fin temperature thermistor during compressor operating.	<ul style="list-style-type: none"> Check the characteristic of the fin temperature thermistor. Check the connector. (CN663)
		P.C. board temperature thermistor	When a short or open circuit occurs in the P.C. board temperature thermistor during compressor operating.	<ul style="list-style-type: none"> Replace the outdoor electronic control P.C. board.
Lighting	5 times	Evaporation temperature thermistor	When a short or open circuit occurs in the evaporation temperature thermistor during compressor operating.	<ul style="list-style-type: none"> Check the characteristic of the evaporation temperature thermistor. Check the connector. (CN662)
Lighting	5 times	High-pressure protect thermistor	When high-pressure protect thermistor is short or open while compressor is operating.	<ul style="list-style-type: none"> Check the characteristic of the high pressure protect thermistor. Check the connector. (CN662)
Lighting	10 times	Gas pipe temperature A thermistor	When a short or open circuit occurs in the gas pipe temperature A thermistor during compressor operating.	<ul style="list-style-type: none"> Check the characteristic of the gas pipe temperature A thermistor. Check the connector. (CN661)
		Gas pipe temperature B thermistor	When a short or open circuit occurs in the gas pipe temperature B thermistor during compressor operating.	<ul style="list-style-type: none"> Check the characteristic of the gas pipe temperature B thermistor. Check the connector. (CN661)
Twice	Goes out	Overcurrent protection	When overcurrent is applied to the power module.	<ul style="list-style-type: none"> Check the inverter/compressor. Check the amount of gas. Check the indoor/outdoor air flow for short cycle. Check the indoor unit air filter for clogging.
3 times	Goes out	Discharge temperature overheat protection	When the discharge temperature thermistor detects 116°C or above. (Protection will be released at 100°C or below.)	<ul style="list-style-type: none"> Check the amount of gas and the refrigerant cycle. Check the outdoor unit air passage.
4 times	Goes out	Fin temperature overheat protection	When the fin temperature thermistor detects 87°C or above.	<ul style="list-style-type: none"> Check the outdoor unit air passage. Check the outdoor fan motor. Check the power module.
4 times	Goes out	P.C. board temperature overheat protection	When the P.C. board temperature thermistor detects 70°C or above.	<ul style="list-style-type: none"> Check the outdoor unit air passage. Check the outdoor fan motor. Replace the outdoor electronic control P.C. board.
5 times	Goes out	High-pressure protection	When high-pressure protect thermistor detects 69°C or more.	<ul style="list-style-type: none"> Check the outdoor unit air passage. Check the outdoor fan motor.



Symptom: Outdoor unit operates (The compressor operates at reduced frequency)				
Indication		Abnormal point	Detecting method	Check points
LED 1 (Red)	LED 2 (Yellow)			
Once	Lighting	Current protection	When the outdoor unit input current exceeds 13A.	These symptoms do not mean any abnormality of the product, but check the following points. <ul style="list-style-type: none"> • Air filter clogging • Amount of gas • Short cycle of indoor/outdoor air flow
Twice	Lighting	High-pressure protection	When indoor gas pipe temperature exceeds 55°C during heating.	
Twice	Lighting	Defrosting in cooling	When indoor gas pipe temperature falls to 6°C or below during cooling.	
3 times	Lighting	Discharge temperature protection	When the discharge temperature exceeds 104°C.	
4 times	Lighting	Low discharge temperature protection	When the state with low discharge temperature of which 37°C or below in COOL and 35°C or below in HEAT for lasts 20 minutes.	
5 times	Lighting	High-pressure protection	When high-pressure protect thermistor detects 58°C or more.	
6 times	Lighting	Overload protection	When the compressor load exceeds the specified value.	

Symptom: Outdoor unit operates.				
Indication		Abnormal point	Detecting method	Check points
LED 1 (Red)	LED 2 (Yellow)			
Lighting	5 times	Defrost thermistor	When a short or open circuit occurs in the defrost thermistor during heating.	<ul style="list-style-type: none"> • Check the characteristic of the defrost temperature thermistor. • Check the connector. (CN662)
Lighting	6 times	Power factor detection	When the compressor power factor cannot be detected.	<ul style="list-style-type: none"> • Check the compressor wiring.
8 times	Lighting	Active filter module protection	When active filter module self-protection has been performed.	
9 times	Lighting	Service mode	When operating unit with compressor relay connector disconnected.	

MXZ-A26WV - [E1]

MXZ-A32WV - [E1]

LED 1 (Red)	LED 2 (Yellow)	Error mode
Lighting	Lighting	Normal

Symptom: Outdoor unit does not operate.				
Indication		Abnormal point	Detecting method	Check points
LED 1 (Red)	LED 2 (Yellow)			
Lighting	Once	Indoor unit and LEV	When the drain abnormality is detected in the indoor unit and the indoor unit coil temperature is too low, or when any abnormality is detected in the components of indoor unit.	<ul style="list-style-type: none"> • Check the abnormality indication on the indoor unit. • Check the LEV.
Lighting	Twice	Outdoor power system	When the compressor operation has been interrupted by over current protection continuously three times within 1 minute after start-up, or when power factor control module protection or DC control protection is activated three times within 3 minutes after the compressor get started.	<ul style="list-style-type: none"> • Check the inverter/compressor.
Lighting	7 times	Outdoor control system	When the nonvolatile memory data cannot be read properly on the outdoor electronic control P.C. board.	<ul style="list-style-type: none"> • Replace the outdoor electronic control P.C. board.

Symptom: It is repeated that outdoor unit stops and restarts 3 minutes later.				
Indication		Abnormal point	Detecting method	Check points
LED 1 (Red)	LED 2 (Yellow)			
Lighting	3 times	Discharge temperature thermistor	When a short or open circuit occurs in the discharge temperature thermistor during compressor operating.	<ul style="list-style-type: none"> • Check the characteristic of the discharge temperature thermistor. • Check the connector. (CN661)
Lighting	4 times	Fin temperature thermistor	When a short or open circuit occurs in the fin temperature thermistor during compressor operating.	<ul style="list-style-type: none"> • Check the characteristic of the fin temperature thermistor. • Check the connector. (CN3)
		P.C. board temperature thermistor	When a short or open circuit occurs in the P.C. board temperature thermistor during compressor operating.	<ul style="list-style-type: none"> • Replace the outdoor electronic control P.C. board.
Lighting	5 times	Evaporation temperature thermistor	When a short or open circuit occurs in the evaporation temperature thermistor during compressor operating.	<ul style="list-style-type: none"> • Check the characteristic of the evaporation temperature thermistor. • Check the connector. (CN661)
Lighting	5 times	Outdoor heat exchanger temperature thermistor	When outdoor heat exchanger temperature thermistor is short or open while compressor is operating.	<ul style="list-style-type: none"> • Check the characteristic of the outdoor heat exchanger temperature thermistor. • Check the connector. (CN661)
Lighting	6 times	Current sensor	When the output from compressor current sensor becomes 25A or more while the compressor is operating.	<ul style="list-style-type: none"> • Check if the connection lead wires of compressor are correctly connected.
Lighting	10 times	Gas pipe temperature A thermistor	When a short or open circuit occurs in the gas pipe temperature A thermistor during compressor operating.	<ul style="list-style-type: none"> • Check the characteristic of the gas pipe temperature A thermistor. • Check the connector. (CN662)
		Gas pipe temperature B thermistor	When a short or open circuit occurs in the gas pipe temperature B thermistor during compressor operating.	<ul style="list-style-type: none"> • Check the characteristic of the gas pipe temperature B thermistor. • Check the connector. (CN662)
		Gas pipe temperature C thermistor	When a short or open circuit occurs in the gas pipe temperature C thermistor during compressor operating.	<ul style="list-style-type: none"> • Check the characteristic of the gas pipe temperature C thermistor. • Check the connector. (CN662)
		Gas pipe temperature D thermistor	When a short or open circuit occurs in the gas pipe temperature D thermistor during compressor operating.	<ul style="list-style-type: none"> • Check the characteristic of the gas pipe temperature D thermistor. • Check the connector. (CN662)
Lighting	11 times	Communication error between P.C. boards	When the communication failure between the outdoor electronic control P.C. board and power board occurs twice consecutively.	<ul style="list-style-type: none"> • Check if the connection wires between outdoor electronic control P.C. board and power board are correctly connected.
Lighting	12 times	Zero cross signal error	When zero cross signal cannot be detected while the compressor is operating.	<ul style="list-style-type: none"> • Check if the connection wires between noise filter P.C. board and power board are correctly connected.
Twice	Goes out	Overcurrent protection	When overcurrent is applied to the power module.	<ul style="list-style-type: none"> • Check the inverter/compressor. • Check the amount of gas. • Check the indoor/outdoor air flow for short cycle. • Check the indoor unit air filter for clogging.
3 times	Goes out	Discharge temperature overheat protection	When the discharge temperature thermistor detects 116°C or above. (Protection will be released at 100°C or below.)	<ul style="list-style-type: none"> • Check the amount of gas and the refrigerant cycle. • Check the outdoor unit air passage.
4 times	Goes out	Fin temperature overheat protection	When the fin temperature thermistor detects 87°C or above.	<ul style="list-style-type: none"> • Check the outdoor unit air passage. • Check the outdoor fan motor. • Check the power module.



Symptom: It is repeated that outdoor unit stops and restarts 3 minutes later				
Indication		Abnormal point	Detecting method	Check points
LED 1 (Red)	LED 2 (Yellow)			
4 times	Goes out	P.C. board temperature overheat protection	When the P.C. board temperature thermistor detects 70°C or above.	<ul style="list-style-type: none"> • Check the outdoor unit air passage. • Check the outdoor fan motor. • Replace the outdoor electronic control P.C. board.
5 times	Goes out	High-pressure protection	When outdoor heat exchanger temperature thermistor detects 69°C or more. When high-pressure switch detects 4MPa or more.	<ul style="list-style-type: none"> • Check the outdoor unit air passage. • Check the outdoor fan motor.
8 times	Goes out	Power factor control module protection	When the overcurrent to power factor controller occurs or the output voltage from power factor controller becomes 400V or more.	<ul style="list-style-type: none"> • Check the input voltage. • Check the inverter.
9 times	Goes out	DC voltage protection	When it's detected that DC voltage becomes 200V or less, or reaches 400V or more.	<ul style="list-style-type: none"> • Check the voltage of power supply. • Check the inverter.
13 times	Goes out	Fan motor protection	When fan motor current is 2A or more, or when the abnormality is detected in the feedback signal from fan motor.	<ul style="list-style-type: none"> • Check the outdoor fan motor. • Check the fan motor connector.

Symptom: Outdoor unit operates (The compressor operates at reduced frequency)				
Indication		Abnormal point	Detecting method	Check points
LED 1 (Red)	LED 2 (Yellow)			
Once	Lighting	Current protection	When the outdoor unit input current exceeds 14.5A.	These symptoms do not mean any abnormality of the product, but check the following points. <ul style="list-style-type: none"> • Air filter clogging • Amount of gas • Short cycle of indoor/outdoor air flow
Twice	Lighting	High-pressure protection	When indoor gas pipe temperature exceeds 55°C during heating.	
Twice	Lighting	Defrosting in cooling	When indoor gas pipe temperature falls to 6°C or below during cooling.	
3 times	Lighting	Discharge temperature protection	When the discharge temperature exceeds 104°C.	
4 times	Lighting	Low discharge temperature protection	When the state with low discharge temperature of which 37°C or below in COOL and 35°C or below in HEAT lasts for 20 minutes.	
5 times	Lighting	High-pressure protection	When outdoor heat exchanger temperature thermistor detects 58°C or more.	

Symptom: Outdoor unit operates.				
Indication		Abnormal point	Detecting method	Check points
LED 1 (Red)	LED 2 (Yellow)			
Lighting	5 times	Defrost thermistor	When a short or open circuit occurs in the defrost thermistor during heating.	<ul style="list-style-type: none"> • Check the characteristic of the defrost temperature thermistor. • Check the connector. (CN661)
9 times	Lighting	Service mode	When the unit operates EMERGENCY OPERATION.	

MXZ-A14WV -[E1] MXZ-A18WV -[E1] MXZ-A26WV -[E1] MXZ-A32WV -[E1]

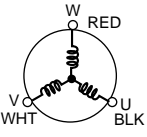
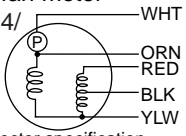
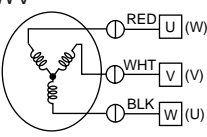
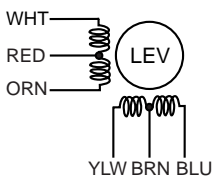
Part name	Check method and criterion																		
Defrost thermistor Evaporation/ Gas pipe/ High-pressure protect/ Outdoor heat exchanger temperature thermistor	Measure the resistance using a tester. (Part temperature : -10°C ~ 40°C) <table border="1" style="width: 100%; text-align: center;"> <tr> <td>Normal</td> <td>abnormal</td> </tr> <tr> <td>5kΩ ~ 55kΩ</td> <td>Open or short-circuit</td> </tr> </table>			Normal	abnormal	5kΩ ~ 55kΩ	Open or short-circuit												
Normal	abnormal																		
5kΩ ~ 55kΩ	Open or short-circuit																		
Discharge temperature thermistor	Measure the resistance using a tester, after warming up the thermistor by holding by hand. (Part temperature : 20°C ~ 40°C) <table border="1" style="width: 100%; text-align: center;"> <tr> <td>Normal</td> <td>abnormal</td> </tr> <tr> <td>100kΩ ~ 250kΩ</td> <td>Opened or short-circuit</td> </tr> </table>			Normal	abnormal	100kΩ ~ 250kΩ	Opened or short-circuit												
Normal	abnormal																		
100kΩ ~ 250kΩ	Opened or short-circuit																		
Fin temperature thermistor	Measure the resistance using a tester. (Part temperature : 10°C ~ 40°C) <table border="1" style="width: 100%; text-align: center;"> <tr> <td>Normal</td> <td>abnormal</td> </tr> <tr> <td>25kΩ ~ 100kΩ</td> <td>Open or short-circuit</td> </tr> </table>			Normal	abnormal	25kΩ ~ 100kΩ	Open or short-circuit												
Normal	abnormal																		
25kΩ ~ 100kΩ	Open or short-circuit																		
Compressor 	Measure the resistance between terminals using a tester. (Winding temperature : -10°C ~ 40°C) <table border="1" style="width: 100%; text-align: center;"> <tr> <td colspan="2">Normal</td> <td>abnormal</td> </tr> <tr> <td>MXZ-A14/A18WV</td> <td>MXZ-A26/A32WV</td> <td rowspan="2">Open or short-circuit</td> </tr> <tr> <td>1Each phase 2.25Ω ~ 2.76Ω</td> <td>1Each phase 1.29Ω ~ 1.49Ω</td> </tr> </table>			Normal		abnormal	MXZ-A14/A18WV	MXZ-A26/A32WV	Open or short-circuit	1Each phase 2.25Ω ~ 2.76Ω	1Each phase 1.29Ω ~ 1.49Ω								
Normal		abnormal																	
MXZ-A14/A18WV	MXZ-A26/A32WV	Open or short-circuit																	
1Each phase 2.25Ω ~ 2.76Ω	1Each phase 1.29Ω ~ 1.49Ω																		
Outdoor fan motor MXZ-A14/ A18WV  Protector specification Short 87±15°C Open 135±5°C MXZ-A26/ A32WV 	Measure the resistance between lead wires using a tester. (Part temperature : -10°C ~ 40°C) <table border="1" style="width: 100%; text-align: center;"> <tr> <td rowspan="4">Color of lead wire</td> <td>Normal</td> <td rowspan="4">abnormal</td> </tr> <tr> <td>MXZ-A14/A18WV</td> </tr> <tr> <td>WHT - BLK</td> <td rowspan="3">Open or short-circuit</td> </tr> <tr> <td>BLK - YLW</td> </tr> <tr> <td>BLK - RED</td> </tr> <tr> <td rowspan="4">Color of lead wire</td> <td>Normal</td> <td rowspan="4">abnormal</td> </tr> <tr> <td>MXZ-A26/A32WV</td> </tr> <tr> <td>RED - BLK</td> <td rowspan="3">Open or short-circuit (Not including WHT - ORN)</td> </tr> <tr> <td>BLK - WHT</td> </tr> <tr> <td>WHT - RED</td> </tr> </table>			Color of lead wire	Normal	abnormal	MXZ-A14/A18WV	WHT - BLK	Open or short-circuit	BLK - YLW	BLK - RED	Color of lead wire	Normal	abnormal	MXZ-A26/A32WV	RED - BLK	Open or short-circuit (Not including WHT - ORN)	BLK - WHT	WHT - RED
Color of lead wire	Normal	abnormal																	
	MXZ-A14/A18WV																		
	WHT - BLK		Open or short-circuit																
	BLK - YLW																		
BLK - RED																			
Color of lead wire	Normal	abnormal																	
	MXZ-A26/A32WV																		
	RED - BLK		Open or short-circuit (Not including WHT - ORN)																
	BLK - WHT																		
WHT - RED																			
R.V. coil	Measure the resistance using a tester. (Part temperature : -10°C ~ 40°C) <table border="1" style="width: 100%; text-align: center;"> <tr> <td>Normal</td> <td>abnormal</td> </tr> <tr> <td>2.6kΩ ~ 3.3kΩ</td> <td>Open or short-circuit</td> </tr> </table>			Normal	abnormal	2.6kΩ ~ 3.3kΩ	Open or short-circuit												
Normal	abnormal																		
2.6kΩ ~ 3.3kΩ	Open or short-circuit																		
Linear expansion valve 	Measure the resistance using a tester. (Part temperature : -10°C ~ 40°C) <table border="1" style="width: 100%; text-align: center;"> <tr> <td rowspan="5">Color of lead wire</td> <td>Normal</td> <td rowspan="5">Abnormal</td> </tr> <tr> <td>WHT - RED</td> </tr> <tr> <td>RED - ORN</td> <td rowspan="3">Open or short-circuit</td> </tr> <tr> <td>YLW - BRN</td> </tr> <tr> <td>BRN - BLU</td> </tr> </table>			Color of lead wire	Normal	Abnormal	WHT - RED	RED - ORN	Open or short-circuit	YLW - BRN	BRN - BLU								
Color of lead wire	Normal	Abnormal																	
	WHT - RED																		
	RED - ORN		Open or short-circuit																
	YLW - BRN																		
	BRN - BLU																		
High pressure switch (HPS)	MXZ-A26/A32WV <table border="1" style="width: 100%; text-align: center;"> <tr> <td colspan="2">Pressure</td> <td>Normal</td> <td>abnormal</td> </tr> <tr> <td colspan="2">Operation OFF</td> <td rowspan="2">Short</td> <td rowspan="2">Other than those listed at left</td> </tr> <tr> <td rowspan="2">HPS1</td> <td>3.7 ± 0.15MPa</td> </tr> <tr> <td>4.8 ± 0.15MPa</td> <td>Open</td> </tr> </table>			Pressure		Normal	abnormal	Operation OFF		Short	Other than those listed at left	HPS1	3.7 ± 0.15MPa	4.8 ± 0.15MPa	Open				
Pressure		Normal	abnormal																
Operation OFF		Short	Other than those listed at left																
HPS1	3.7 ± 0.15MPa																		
	4.8 ± 0.15MPa	Open																	

Outdoor unit does not operate. (LED display: display OFF)

Ⓐ Check of power supply

MXZ-A14/A18WV

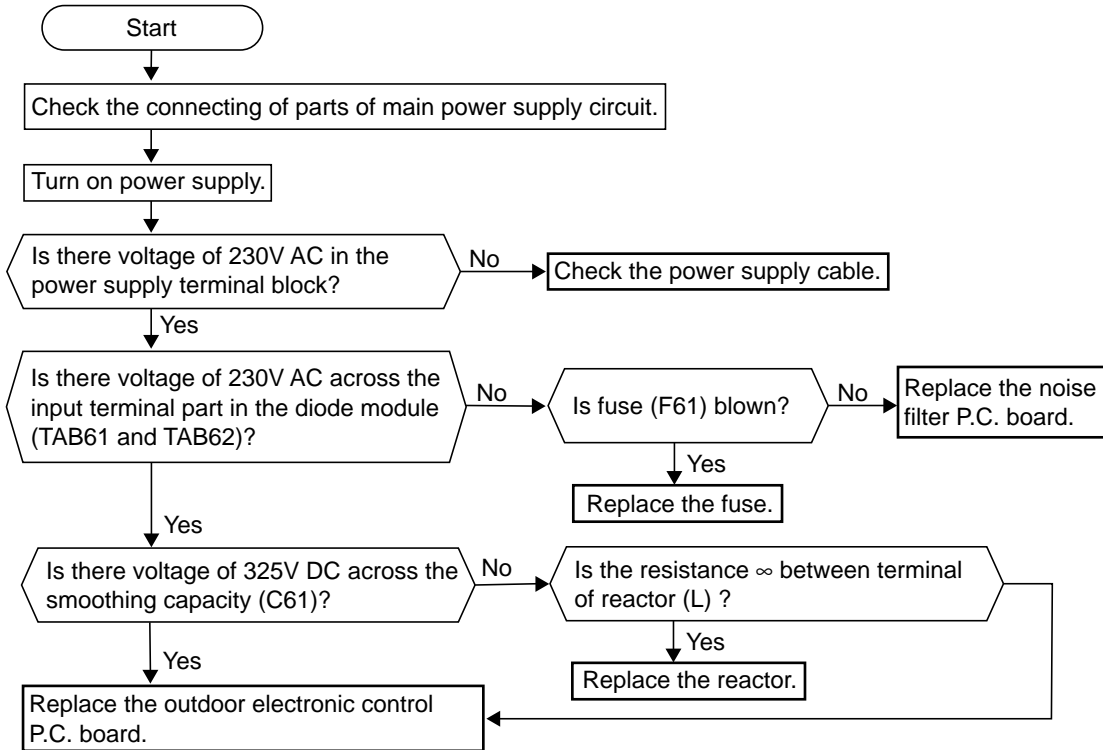

MXZ-A26/A32WV

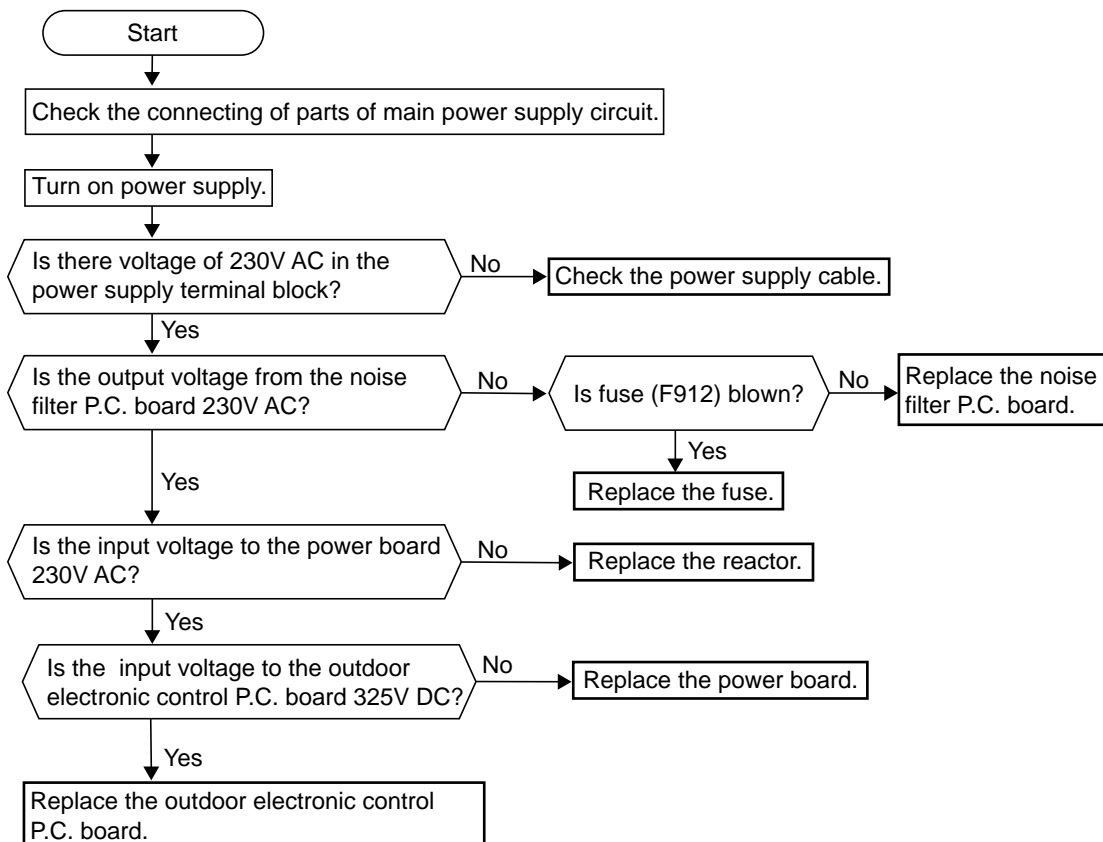

Outdoor unit does not operate. (LED display: Both LED1 and LED2 lighting)

Ⓑ Check of outdoor unit serial signal

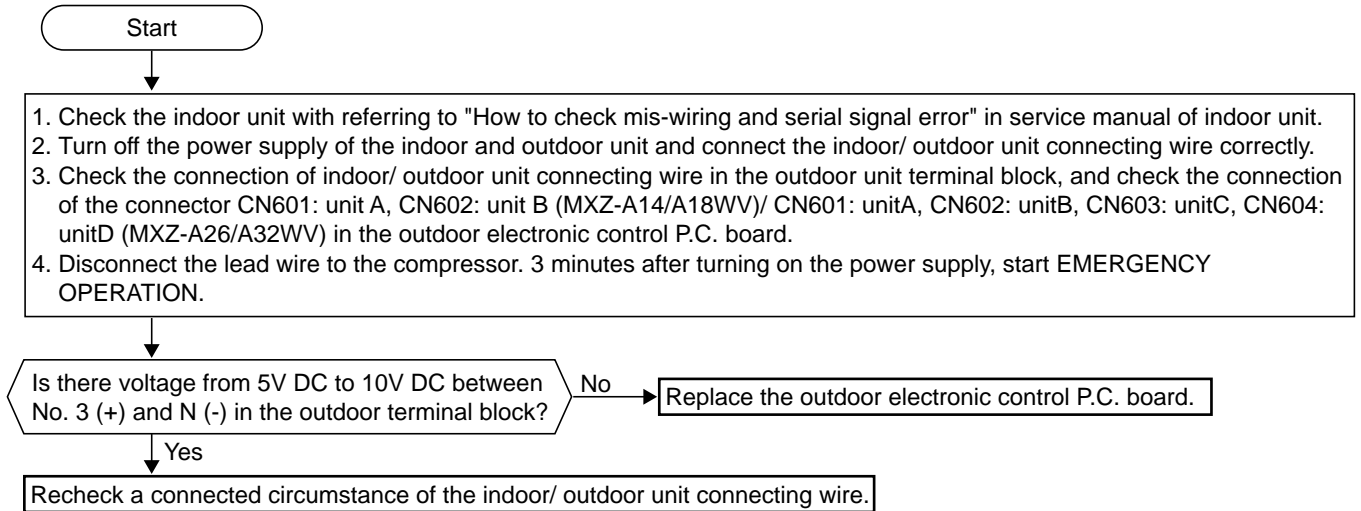

The cooling operation or heating operation does not operate. (LED display: Both LED1 and LED2 lighting)

© Check of R.V. coil

• When heating operation does not work.

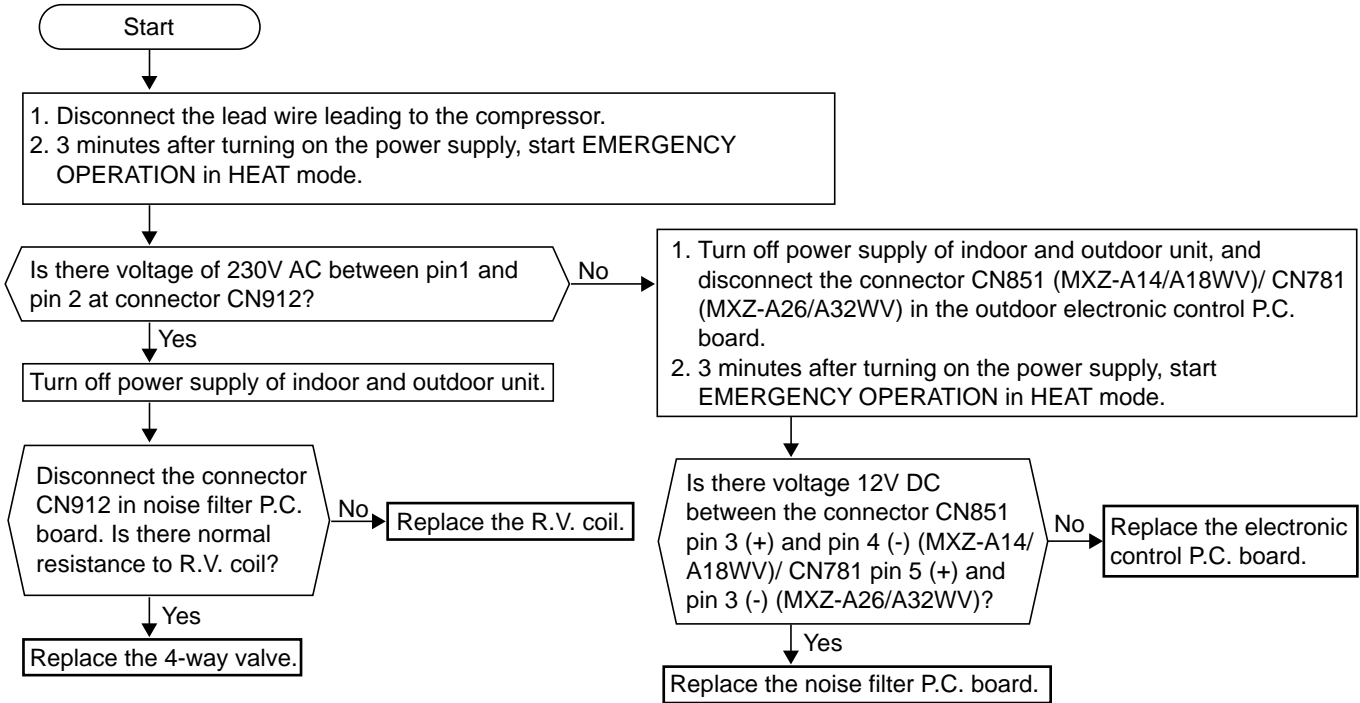

• When cooling operation does not work.

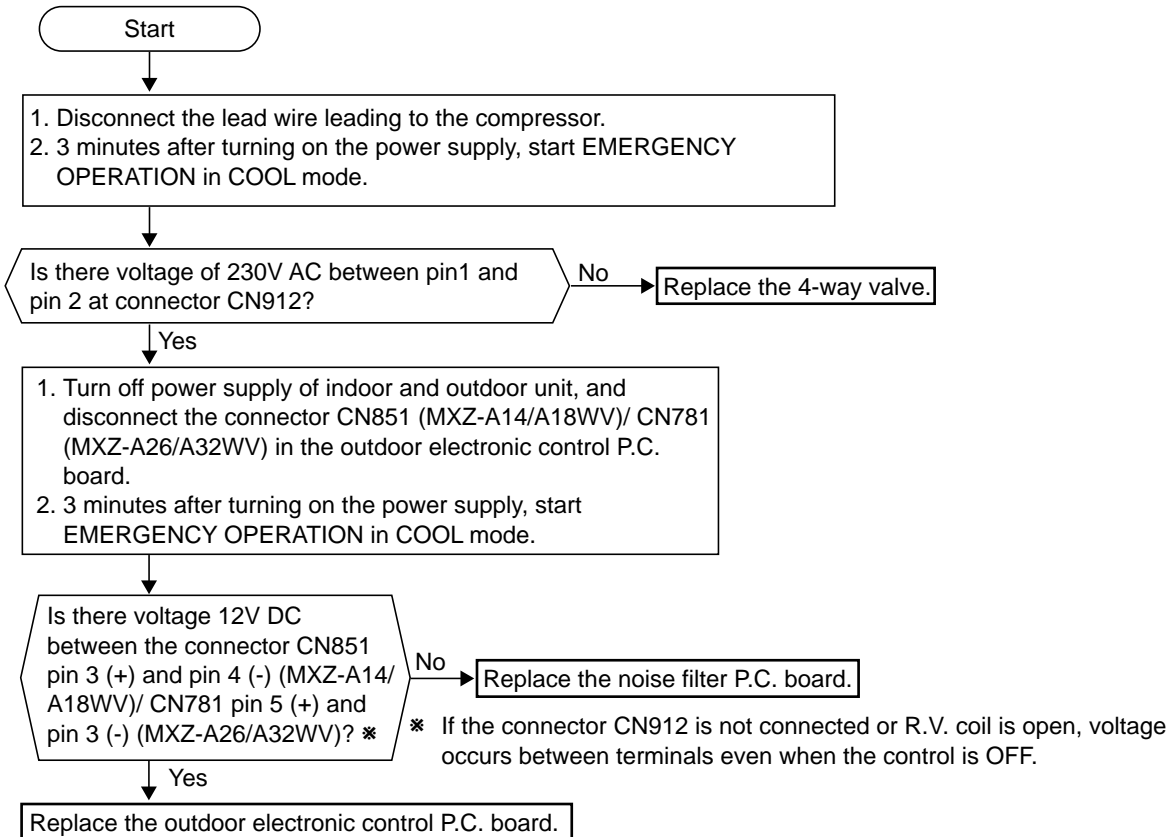

- When cooling, heat exchanger of non-operating indoor unit frosts.
- When heating, non-operating indoor unit get warm.

④ Check of LEV

LED display:

LED1	LED2
Lighting	Lighting
Lighting	Once

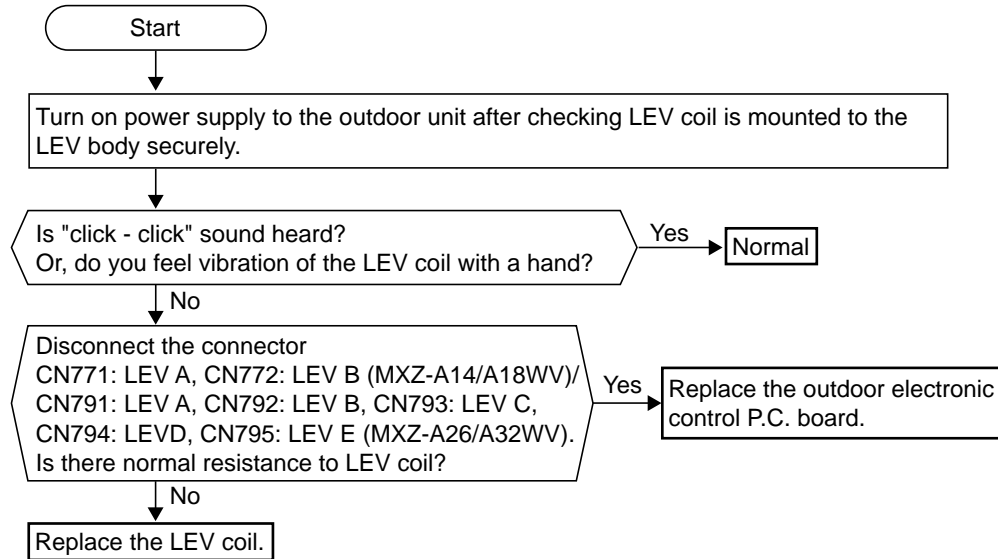

- When heating, room does not get warm.
- When cooling, room does not get cool.

Ⓔ Check of inverter/ compressor

MXZ-A14/A18WV

LED display:

LED1	LED2
Lighting	Lighting
Lighting	Twice
Twice	Goes out

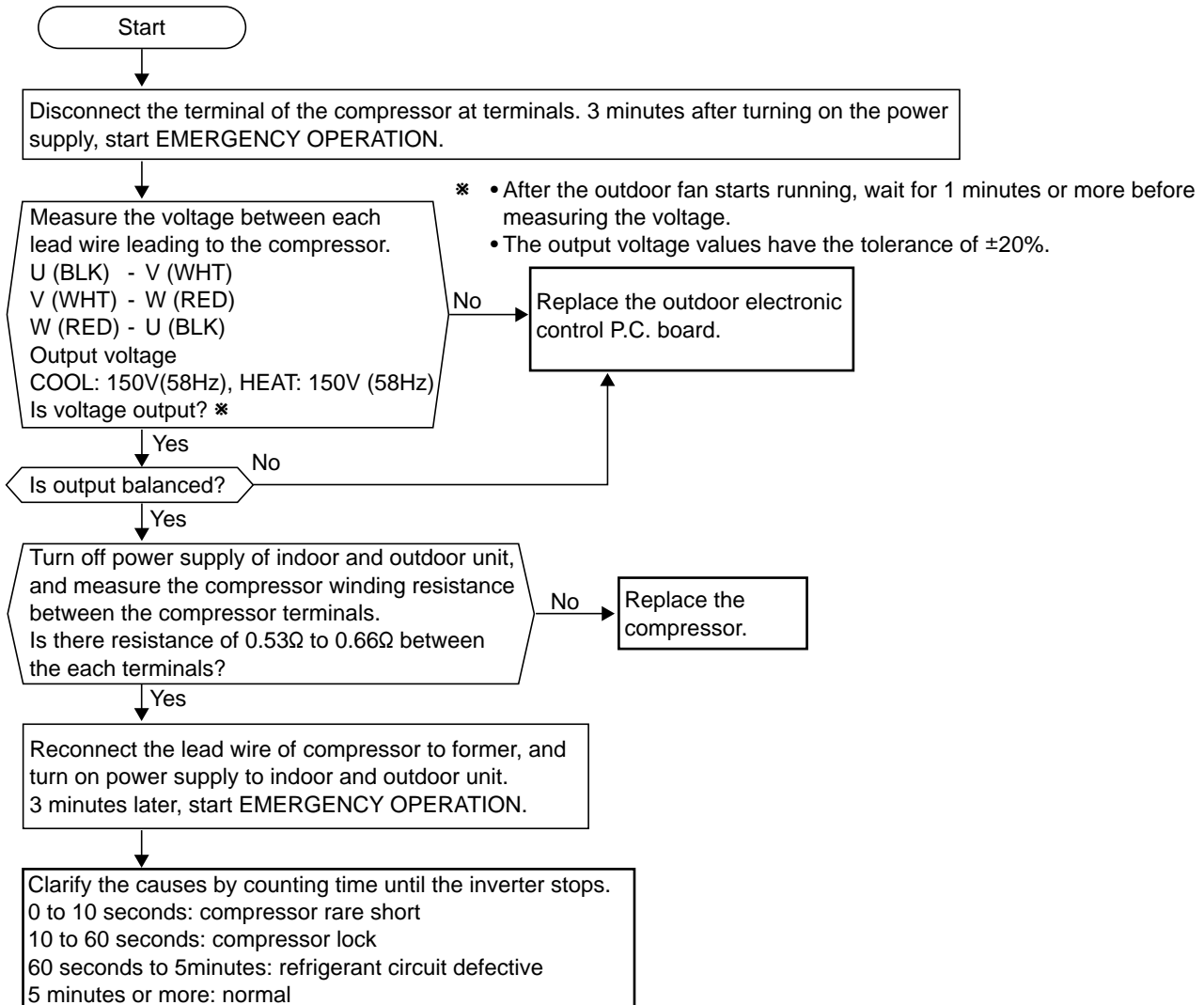

MXZ-A26/A32WV

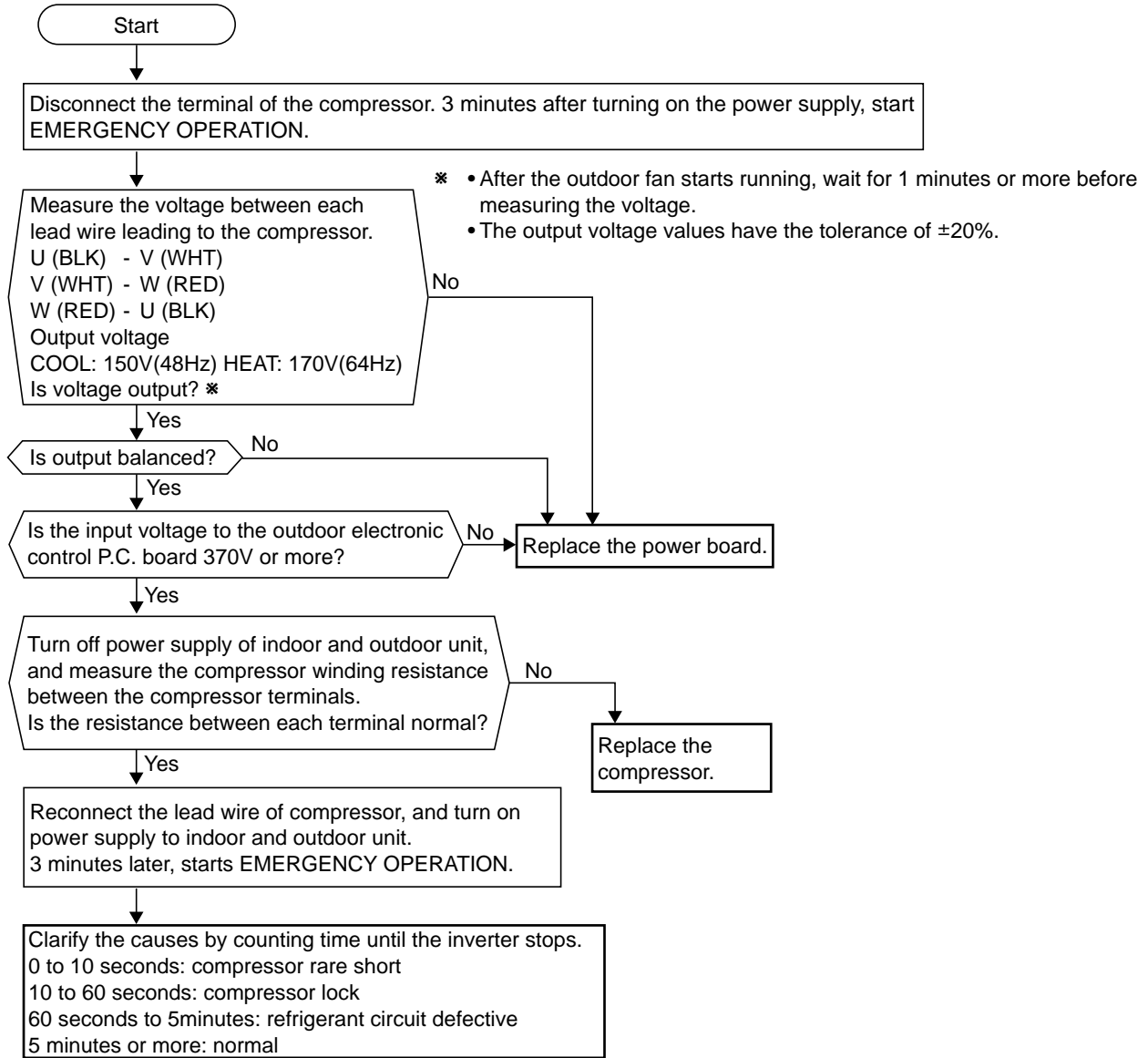

• When thermistor is abnormal. (When the LED display is a table below.)

⑤ Check of outdoor unit thermistors

MXZ-A14/A18WV

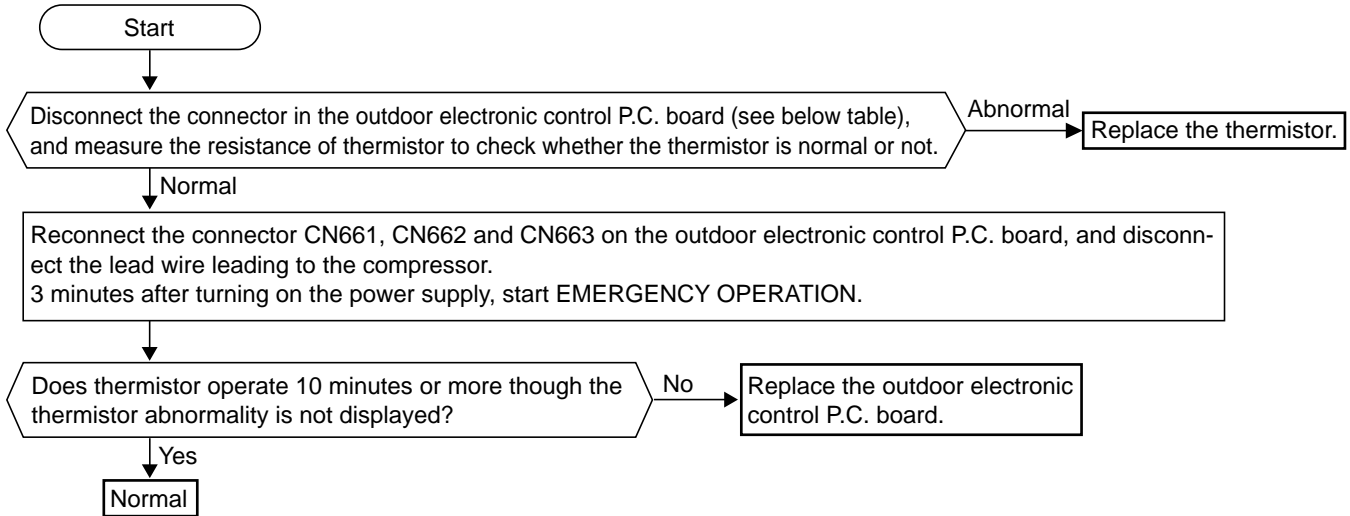

Thermistor	Symbol	Connector, Pin No.
Discharge temperature thermistor	RT61	Between CN662 pin3 and pin4
Defrost thermistor	RT62	Between CN662 pin1 and pin2
Evaporation temperature thermistor	RT63	Between CN662 pin5 and pin6
High-pressure protect thermistor	RT68	Between CN662 pin7 and pin8
Gas pipe temperature A thermistor	RT6A	Between CN661 pin1 and pin2
Gas pipe temperature B thermistor	RT6B	Between CN661 pin3 and pin4
Fin temperature thermistor	RT65	Between CN663 pin1 and pin2

MXZ-A26/A32WV

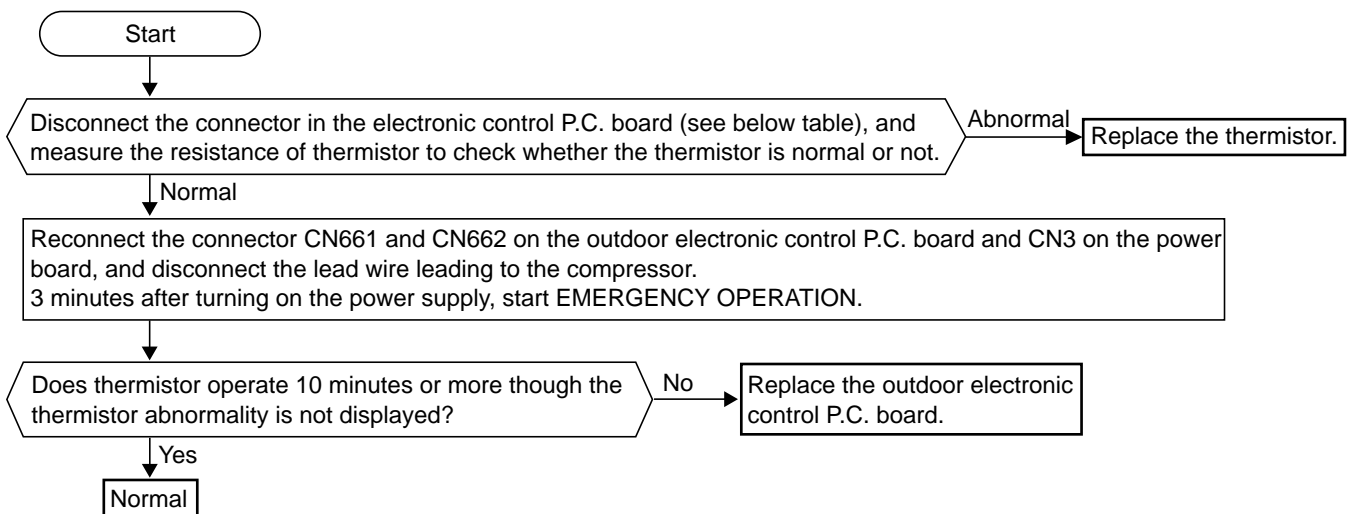

Thermistor	Symbol	Connector, Pin No.
Discharge temperature thermistor	RT61	Between CN661 pin3 and pin4
Defrost thermistor	RT62	Between CN661 pin1 and pin2
Evaporation temperature thermistor	RT63	Between CN661 pin5 and pin6
Outdoor heat exchanger temperature thermistor	RT68	Between CN661 pin7 and pin8
Gas pipe temperature thermistor (Unit A)	RT6A	Between CN662 pin1 and pin2
Gas pipe temperature thermistor (Unit B)	RT6B	Between CN662 pin3 and pin4
Gas pipe temperature thermistor (Unit C)	RT6C	Between CN662 pin5 and pin6
Gas pipe temperature thermistor (Unit D)	RT6D	Between CN662 pin7 and pin8
Fin temperature thermistor	RT65	Between CN3 pin1 and pin2

• Fan motor does not operate or stops operating shortly after starting the operation.

Ⓒ Check of outdoor fan motor

MXZ-A14/A18WV

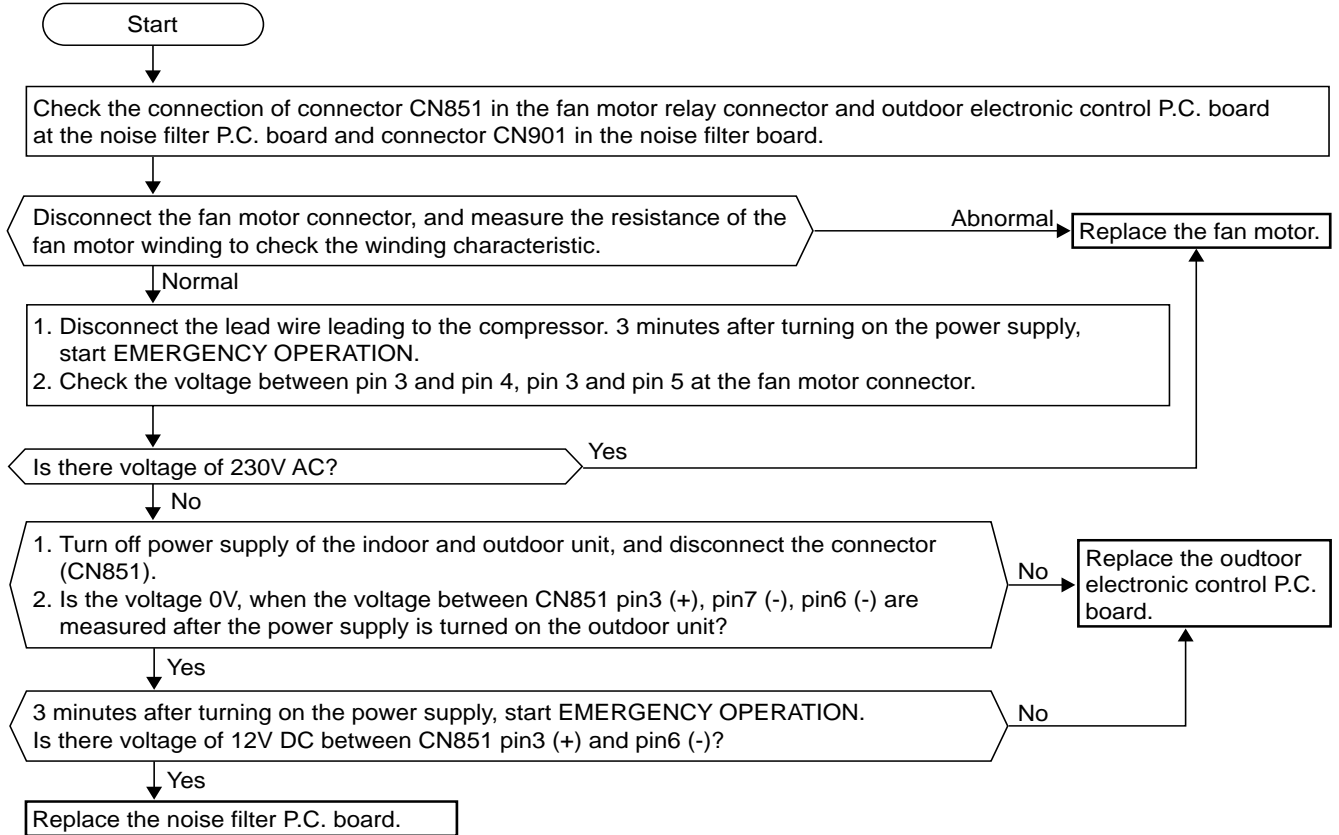

MXZ-A26/A32WV

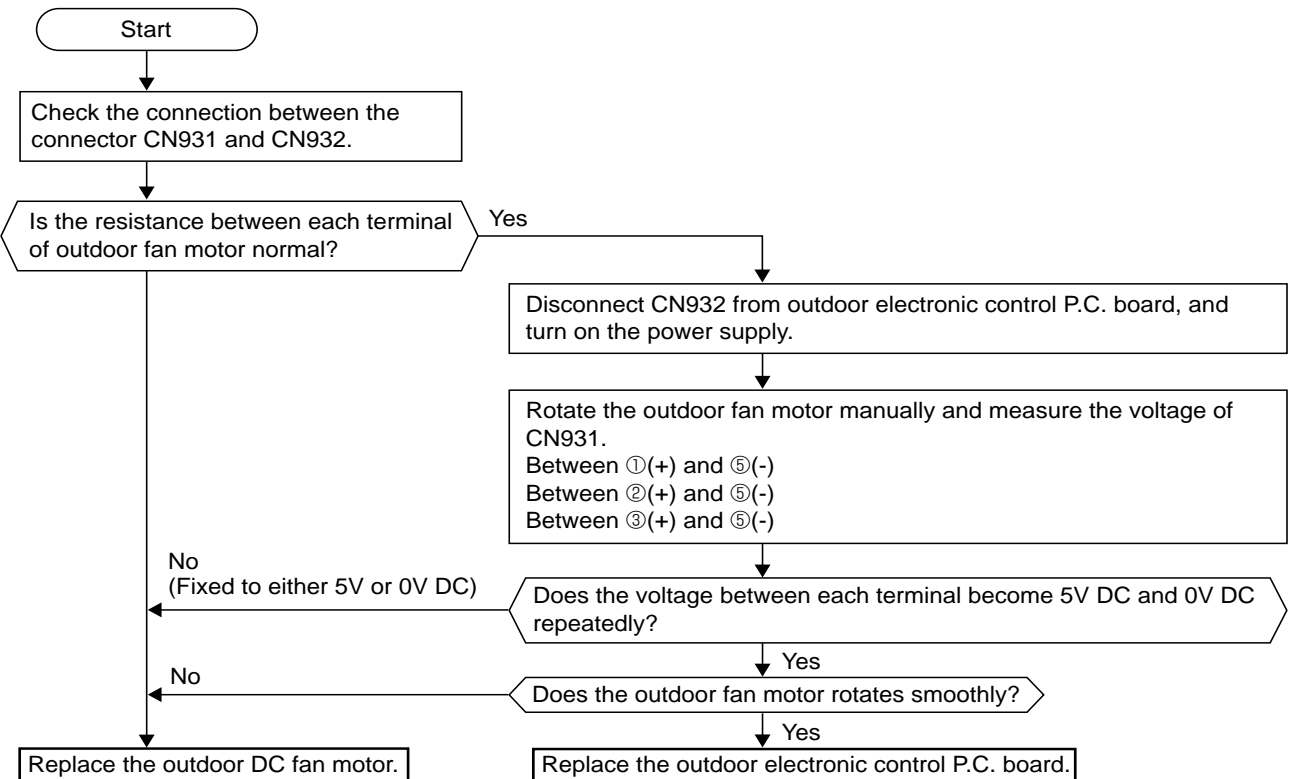

• When the operation frequency does not go up from lowest frequency.

⊕ Check of HPS

MXZ-A26/A32WV

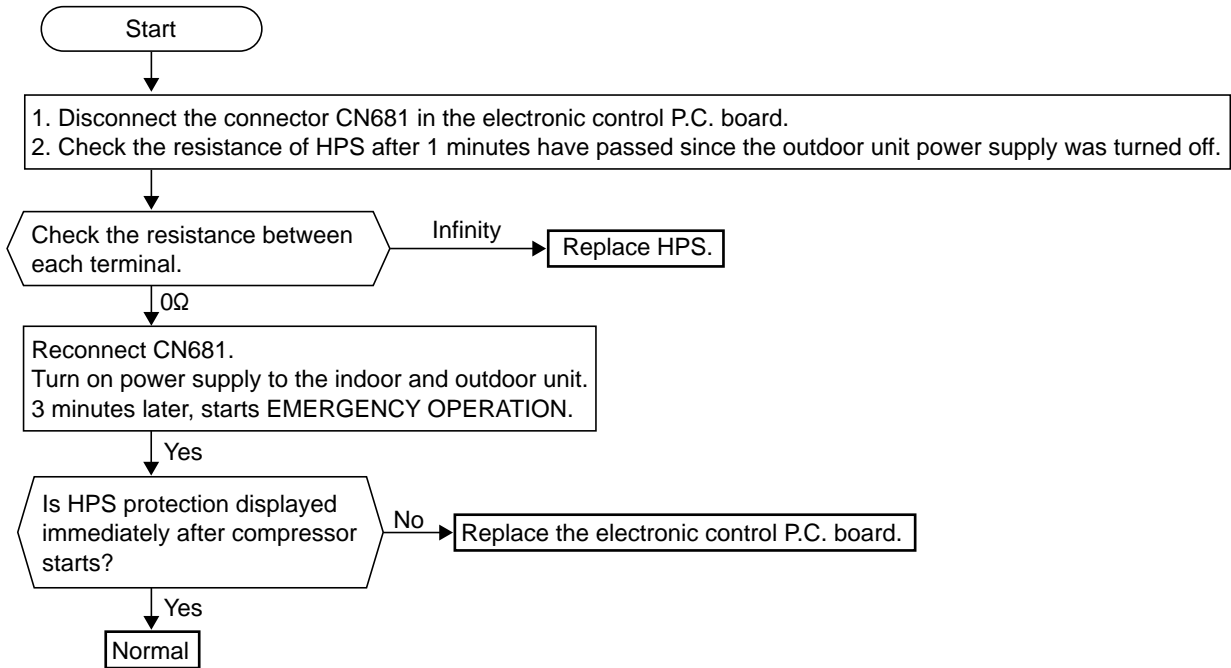

① The other cases

Indoor unit dose not operate. (different operating models in multisystem)

- When you try to run two indoor unit simultaneously, one for cooling and the other for heating, the unit which transmits signal to the outdoor units earlier decides the operation mode. The other unit indicates as shown in the figure below.
- When the above situation occurs, set all the indoor units to the same mode, turn OFF the indoor units, and then turn them back ON.
- Though the top of the indoor unit sometimes gets warm, this does not mean malfunction. The reason is that the refrigerant gas continuously flows into the indoor unit even while it is not operating.

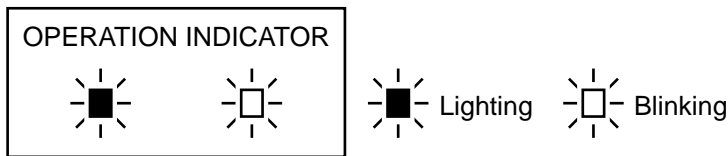

MXZ-A14WV -E1 MXZ-A18WV -E1
Outdoor electronic control P.C. board

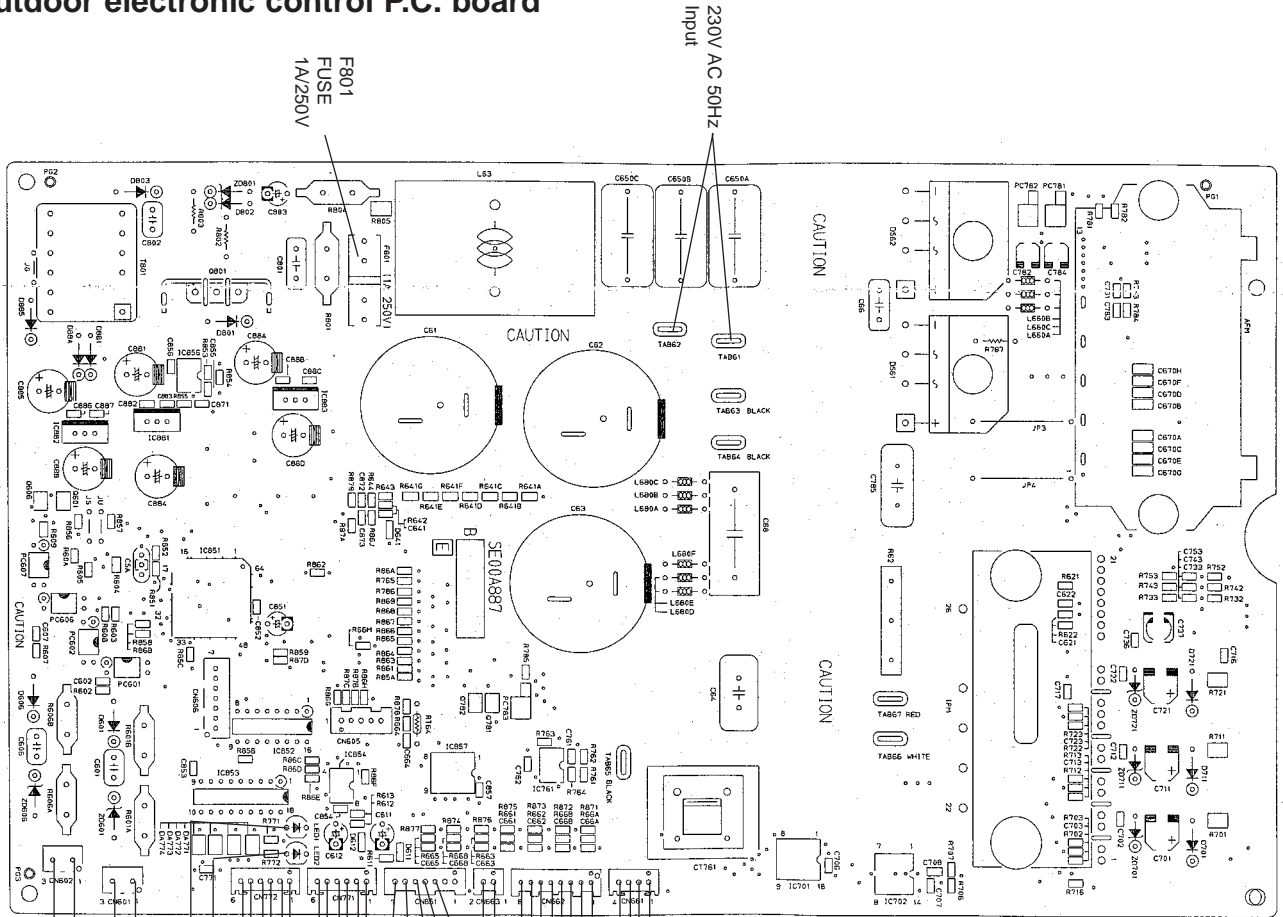

- Gas pipe temperature A thermistor (RT6A) CN661
- Gas pipe temperature B thermistor (RT6B) 661
- Defrost thermistor (RT62) CN662
- Discharge temperature thermistor (RT61) CN661
- Evaporation temperature thermistor (RT63) 662
- High-pressure protect thermistor (RT68) 662
- Fin temperature thermistor (RT65) CN663
- Common (+) CN663
- R.V. coil (-) CN851
- Rush current relay (-) 12V DC
- Outdoor fan "High" (-) 12V DC
- Outdoor fan "Low" (-) 12V DC
- Common (+) CN771 Room A
- Linear expansion valve (LEV) CN772 Room B
- Common (-) 12V DC pulse wave
- Common (+) CN771 Room A
- Linear expansion valve (LEV) CN772 Room B
- Common (-) 12V DC pulse wave
- LED 2
- LED 1
- CN601 5~10V DC Serial signal Room A
- CN602 5~10V DC Serial signal Room B

- Defrost temperature thermistor (RT62)
- Evaporation temperature thermistor (RT63)
- Gas pipe temperature thermistor (RT6A,6B)
- High-pressure protection thermistor (RT68)

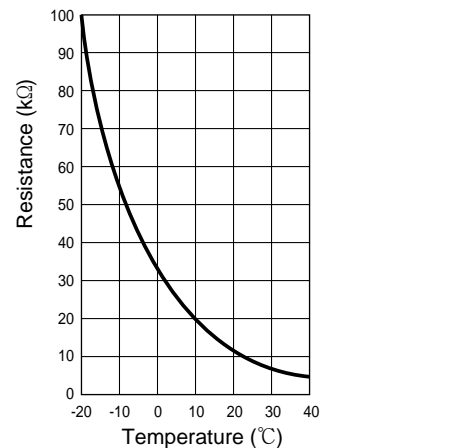
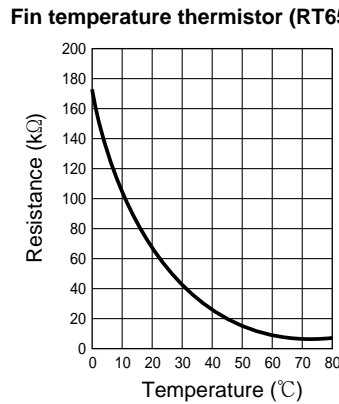
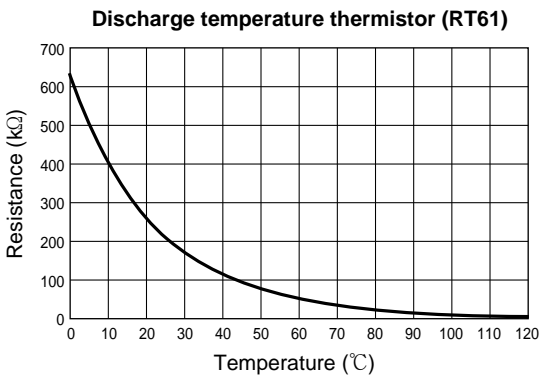

MXZ-A26WV -E1 MXZ-A32WV -E1 Outdoor electronic control P.C. board

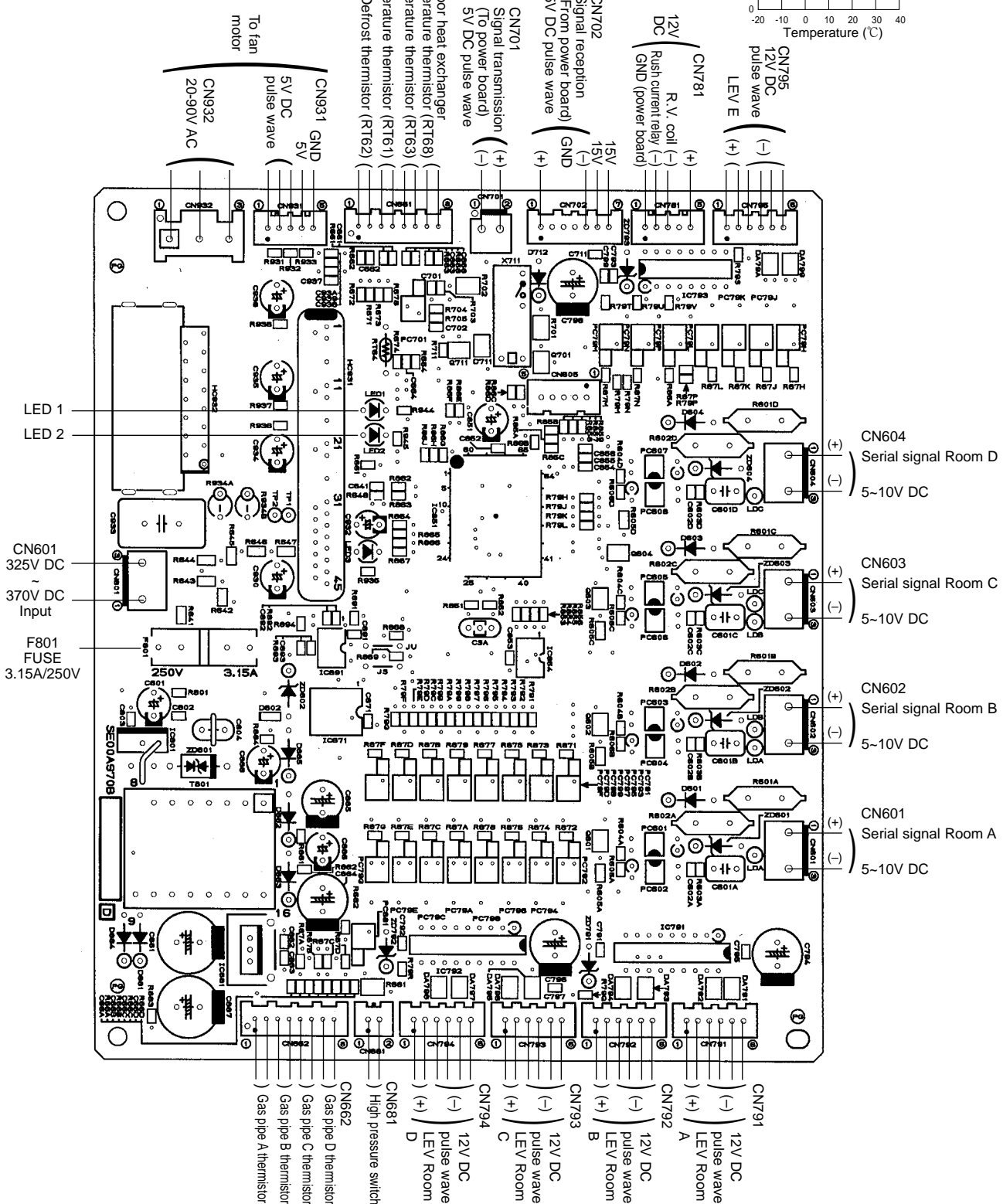
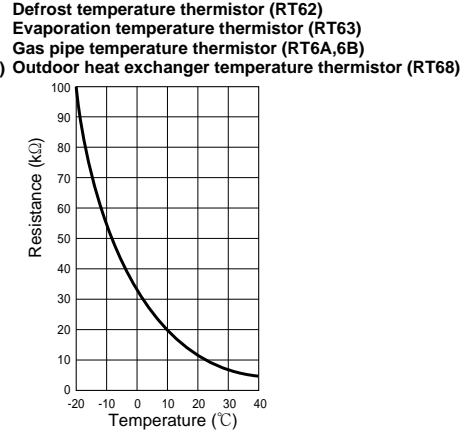
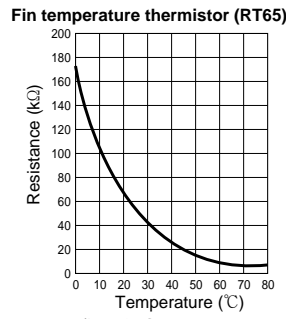
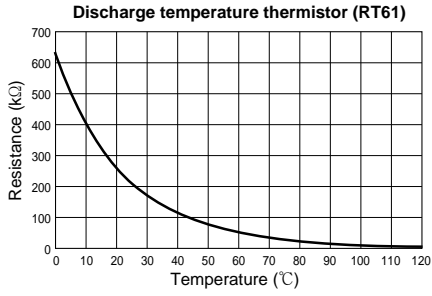

MXZ-A14WV - [E1]
MXZ-A18WV - [E1]
Noise filter P.C. board

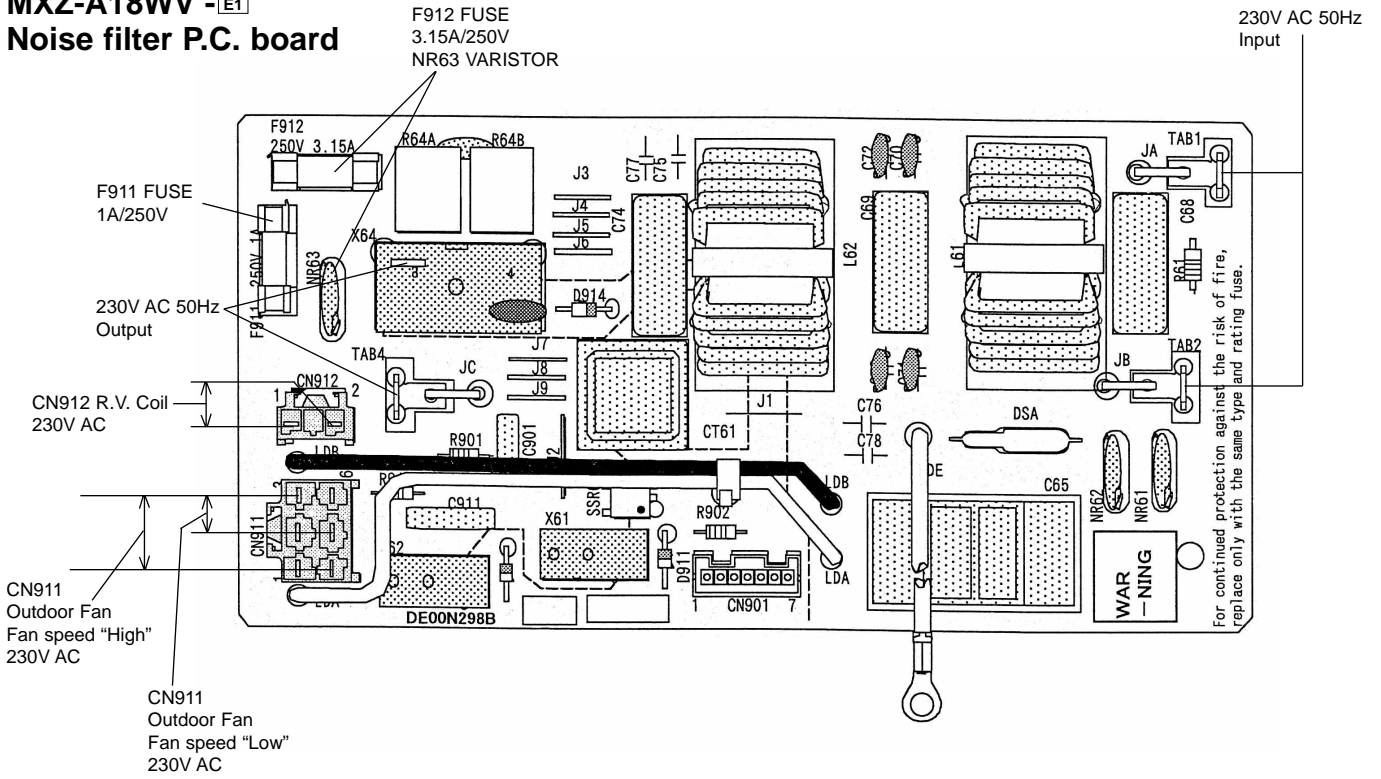

MXZ-A26WV - [E1]
MXZ-A32WV - [E1]
Noise filter P.C. board

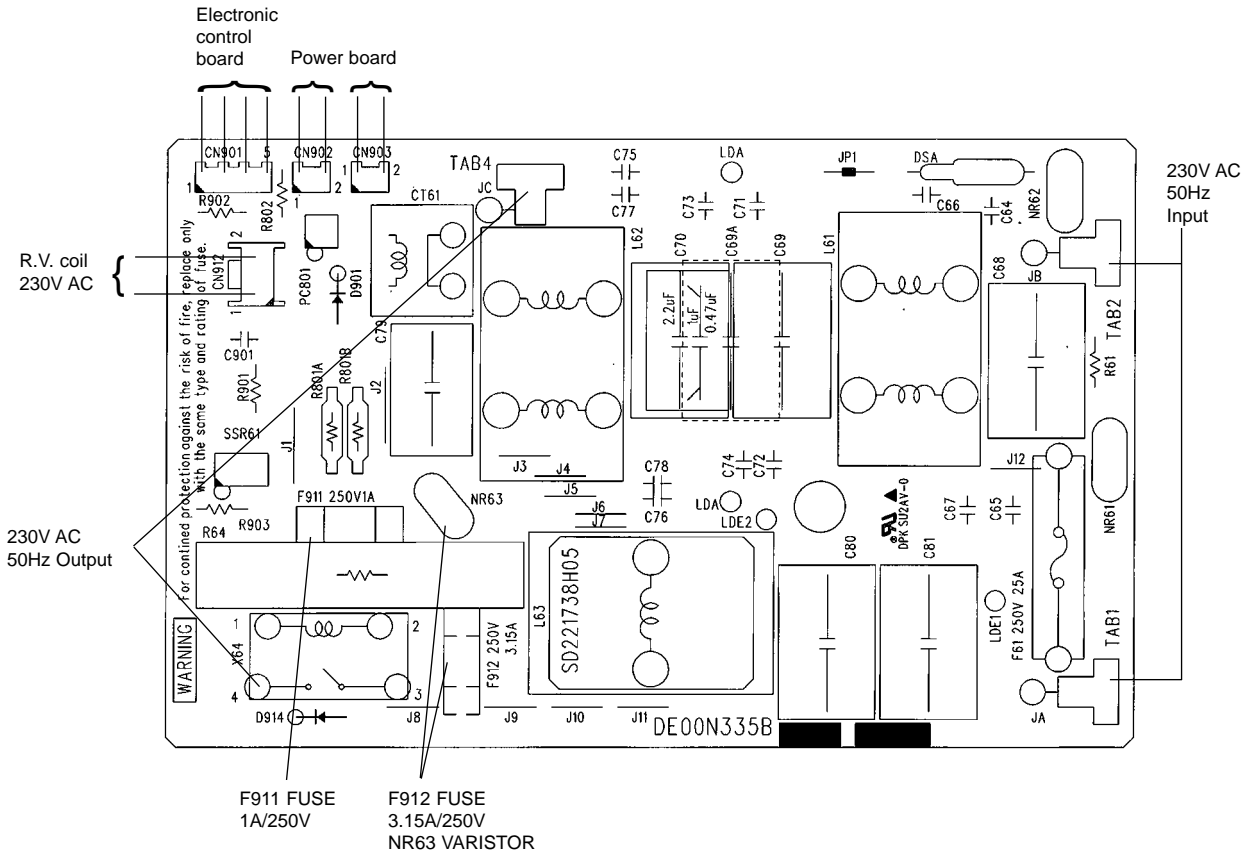

MXZ-A26WV -E1
MXZ-A32WV -E1
Outdoor Power board

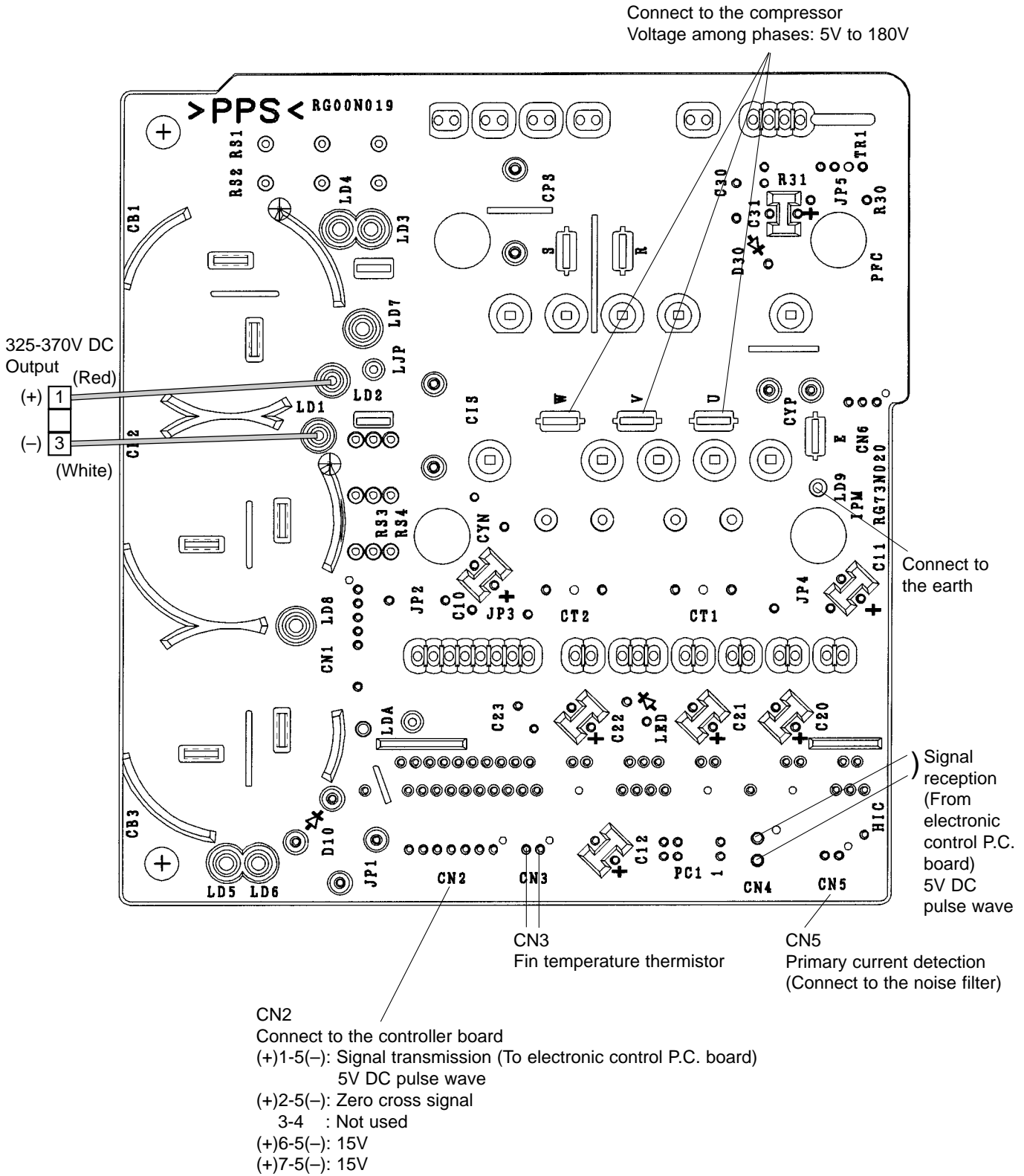

13-1. MXZ-A14WV -E1 MXZ-A18WV -E1 OUTDOOR UNIT

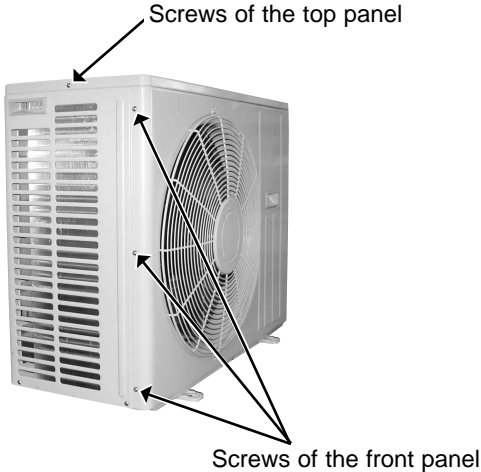
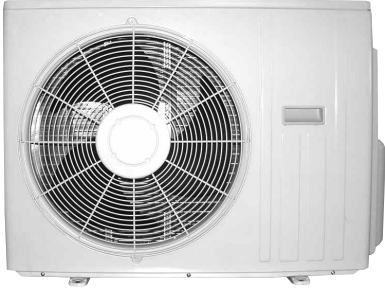
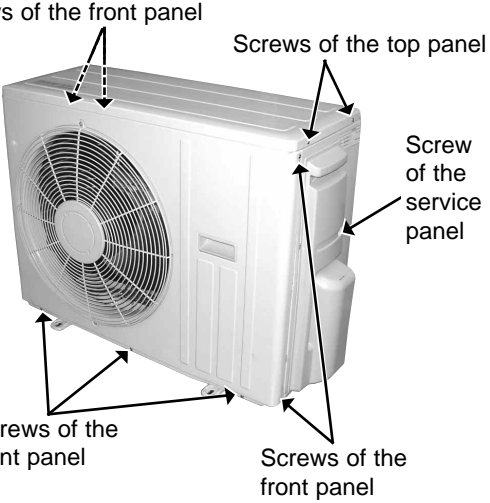
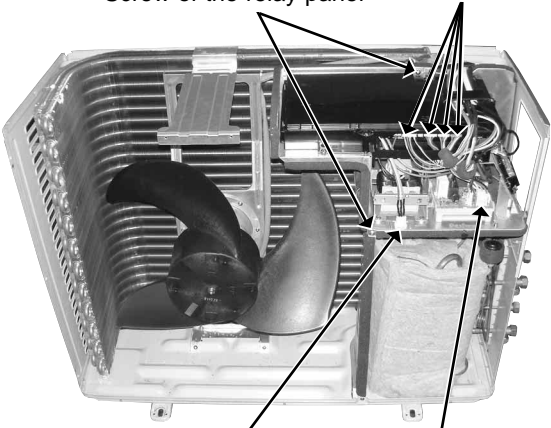
OPERATING PROCEDURE	PHOTOS
<p>1. Removing the cabinet.</p> <p>1. Removing the cabinet.</p> <ol style="list-style-type: none"> (1) Remove the screws of the top panel. (2) Remove the top panel. (3) Remove the screw of the service panel. (4) Remove the service panel. (5) Remove the screws of the front panel. <p>Photo 3</p>  <p>Screws of the top panel</p> <p>Screws of the front panel</p>	<p>Photo 1</p>  <p>Photo 2</p>  <p>Screws of the front panel</p> <p>Screws of the top panel</p> <p>Screw of the service panel</p> <p>Screws of the front panel</p> <p>Screws of the front panel</p>
<p>2. Removing the inverter assembly</p> <ol style="list-style-type: none"> (1) Remove the top panel, service panel and front panel. (2) Remove indoor/outdoor connecting wire and power supply cable. (3) Remove the compressor connector on the compressor side. (4) Remove the connectors for fan motor, LEV, thermistor and R.V. coil from the electronic control P.C. board. (5) Remove the screws of the inverter assembly. (6) Remove the inverter assembly. 	<p>Photo 4</p>  <p>Screw of the relay panel</p> <p>LEV, R.V. coil and thermistor connectors</p> <p>Compressor connector</p> <p>Fan motor connector</p>

OPERATING PROCEDURE

3. Removing the Outdoor Electronic control P.C. board.

- (1) Remove the top panel, service panel and front panel.
- (2) Remove the connector coming out of the compressor.
- (3) Remove the compressor connector, compressor relay connector on the electronic control P.C. board side, terminal of reactor and terminals of TAB4 and X64 of the noise filter P.C. board coming out of the electronic control P.C. board. (Fig. 1)
- (4) Remove the screw fixing the cover of the electronic control P.C. board.
- (5) Remove the cover of the electronic control P.C. board.
- (6) Remove the screw fixing the heat sink.
- (7) Remove the hooks fixing the electronic control P.C. board.
- (8) Disconnect all the connectors and the terminal on the electronic control P.C. board.
- (9) Remove the electronic control P.C. board.

Fig. 1

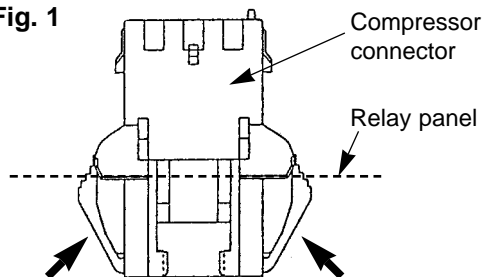

Push up the connector by holding the part shown by the arrows.

4. Removing the propeller and fan motor

- (1) Remove the top panel, service panel and front panel.
- (2) Remove the fan motor connector (CN911) from the noise filter P.C. board.
Remove the inverter assembly and then lead wires from cable clamp.
- (3) Remove the propeller nut.
- (4) Remove the propeller.
- (5) Remove the screws of fan motor.
- (6) Remove the fan motor

PHOTOS

Photo 5

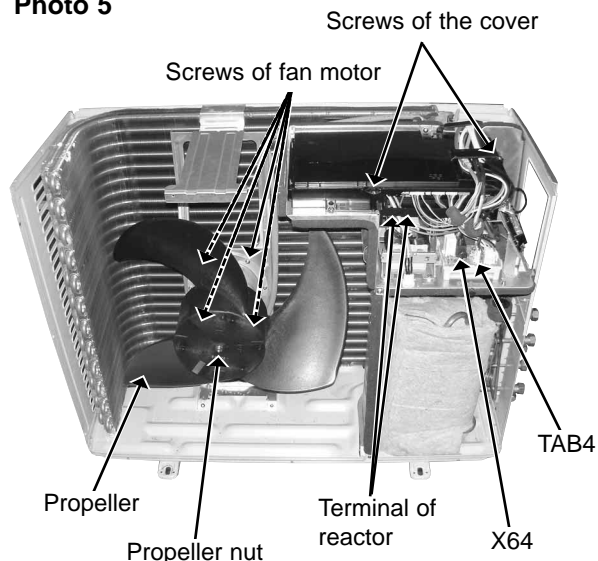

Photo 6

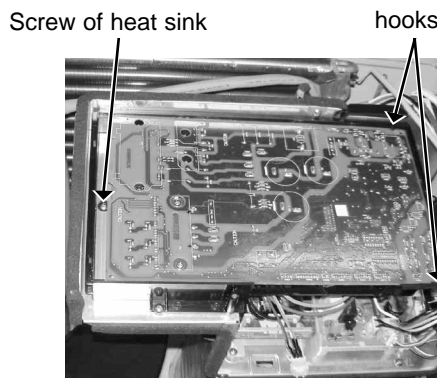
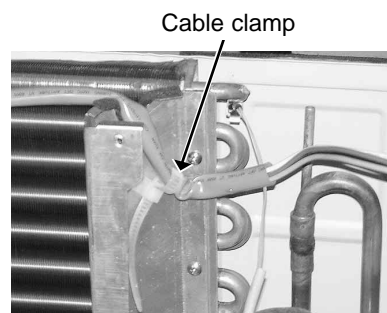

Photo 7



OPERATING PROCEDURE

5. Removing the thermistor

- Discharge temperature thermistor, defrost, evaporator temperature, high-pressure protect, gas pipe temperature A and gas pipe temperature B
- (1) Remove the top panel, service panel, front panel.
 - (2) Remove indoor/outdoor connecting wire and power supply cable.
 - (3) Remove thermistor connector (CN661, CN662) from the electronic control P.C. board.
 - (4) Remove the inverter assembly.
 - (5) Remove the thermistor in the upper part of compressor.
 - (6) Remove the back panel.
 - (7) Remove the thermistors for defrost, evaporator temperature, gas pipe temperature A and gas pipe temperature B.

Do not wipe off silicon oil.
Otherwise the temperature of the electronic control P.C. board may rise unusually.

PHOTOS

Photo 8

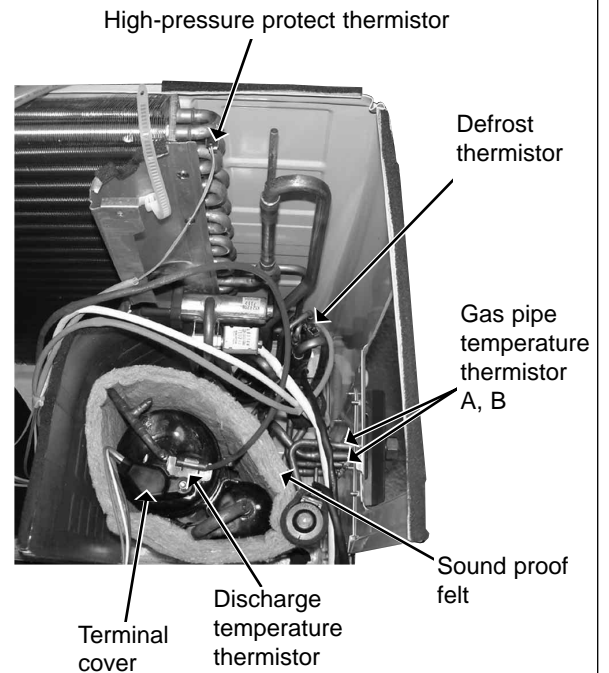
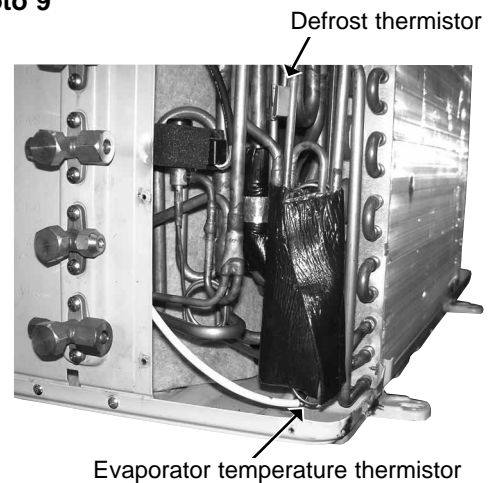

Photo 9



OPERATING PROCEDURE

6. Removing the compressor/4-way valve

- (1) Collect refrigerant from refrigerant circuit.
Caution: If collecting has not been done enough, refrigerating machine oil may spout out or harmful substance may be generated during welding work.
- (2) Remove indoor/outdoor connecting wire and power supply cable.
- (3) Remove the top panel, service panel, front panel and back panel.
- (4) Remove the inverter assembly.
- (5) In case of removing 4-way valve, detach welded parts first.
- (6) Remove the terminal cover then pull out the lead wire from the terminal of compressor.
- Remove the soundproof felt.
- (7) Detach welded parts of compressor suction and discharge pipes.
- (8) Remove the compressor nuts and remove the compressor.

PHOTOS

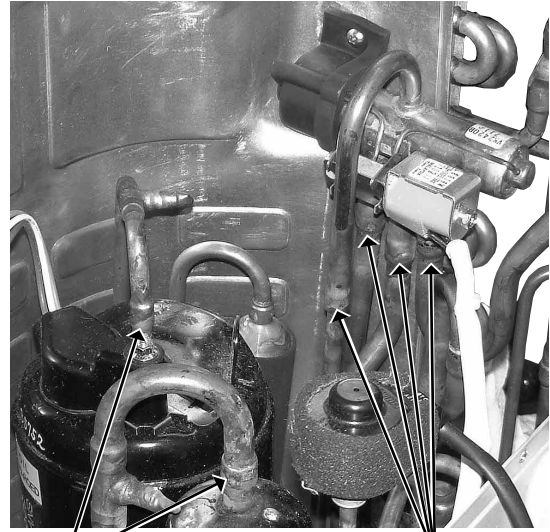
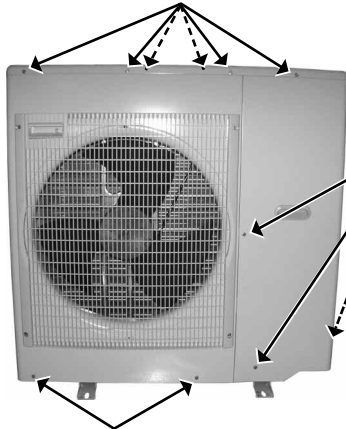
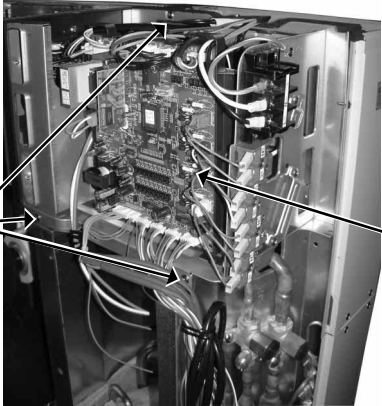

Photo 10



Welded parts of compressor suction and discharge pipes

4-way valve welded parts

13-2. MXZ-A26WV -^{E1} MXZ-A32WV -^{E1}
OUTDOOR UNIT

OPERATING PROCEDURE	PHOTOS
<p>1. Removing the compressor</p> <p>(1) Remove the screws of the top panel, and remove it.</p> <p>(2) Remove the screws of the service panel, and remove it. Recover refrigerant gas.</p> <p>(3) Remove the screws of the front panel, and remove it.</p> <p>(4) Disconnect the compressor lead wire from terminal of compressor. (U, V, W)</p> <p>(5) Disconnect the outdoor electronic control P.C. board connectors. CN661, CN662, CN681, CN791, CN792, CN793, CN794 (MXZ-A32WV), CN795, CN931, CN932 Disconnect the noise filter P.C. board connector. CN912</p> <p>(6) Remove the screws of the electrical parts, and remove the electrical parts.</p> <p>(7) Remove the propeller.</p> <p>(8) Remove the screws of the separator, and remove the separator.</p> <p>(9) Remove the sound proof felt.</p> <p>(10) Detach the welded parts of the compressor suction and discharge pipes. (Photo 3)</p> <p>(11) Remove the compressor nuts and remove the compressor.</p>	<p>Photo 1</p>  <p>Screws of the top panel</p> <p>Screws of service panel</p> <p>Screws of the front panel</p> <p>Photo 2</p>  <p>Screws of the electrical parts</p> <p>Electronic control P.C. board</p> <p>Photo 3</p>  <p>LEV coil</p> <p>Expansion valve</p> <p>Suction pipe welded part</p> <p>Discharge pipe welded part</p> <p>Terminal</p>

OPERATING PROCEDURE

2. Removing the fan motor

- (1) Remove the top panel, the service panel, and the front panel. (Photo 1)
- (2) Disconnect the connector CN911 on the outdoor electronic control P.C. board.
- (3) Remove the propeller.
- (4) Remove the fan motor.

PHOTOS

Photo 4

Screws of the outdoor fan motor

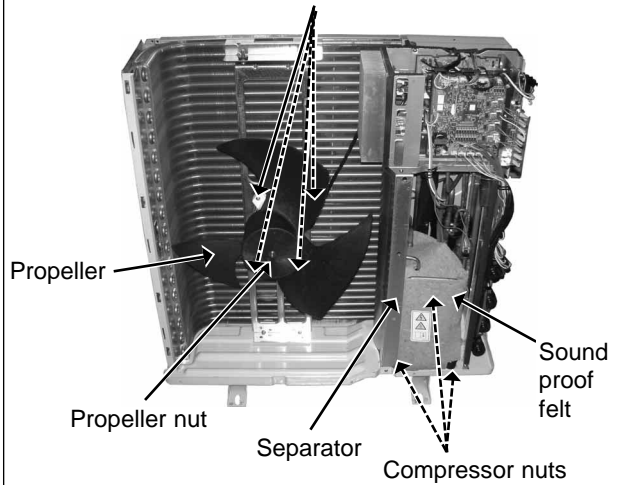

3. Removing the 4-way valve

- (1) Remove the top panel. (Photo 1)
- (2) Remove the service panel, rear panel, and pipe cover. Recover refrigerant gas.
- (3) Remove the electrical parts. (Photo 2)
- (4) Detach the welded parts of 4-way valve and pipe. (Photo 5)

Photo 5

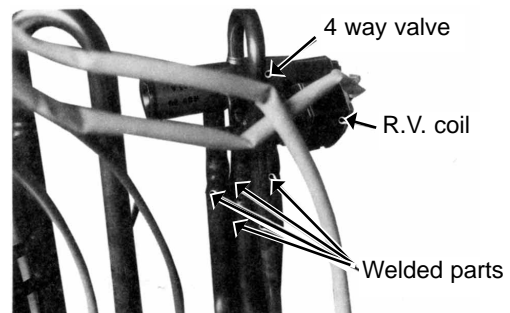

4. Removing the expansion valve

- (1) Remove the top panel. (Photo 1)
- (2) Remove the service panel. (Photo 1) (Gas recovery is not required if the unit is pumped down.)
- (3) Remove the LEV coil.
- (4) Detach the welded parts of expansion valves and pipes.

Photo 6

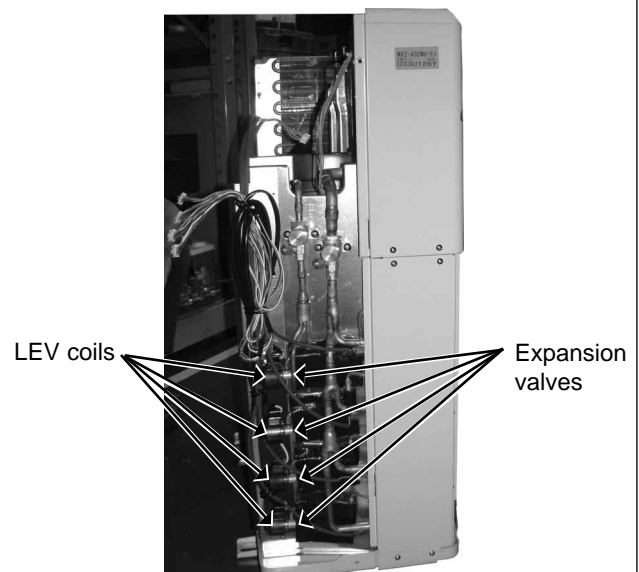

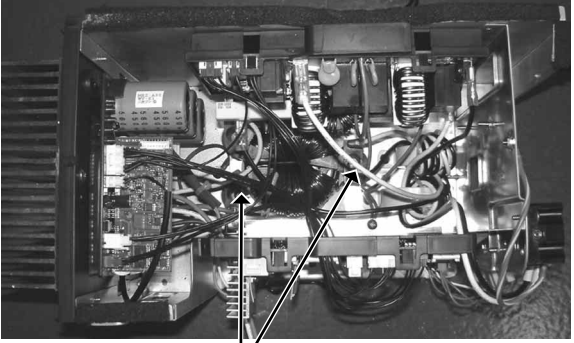

OPERATING PROCEDURE	PHOTOS
<p>5. Removing the reactor</p> <ul style="list-style-type: none">(1) Remove the top panel. (Photo 1)(2) Disconnect the reactor lead wire.(3) Remove the screws of the reactor, and remove the reactor.	<p>Photo 7</p>  <p>Screws of the reactor</p>

MXZ-A14WV -E1

MXZ-A18WV -E1

14-1. OUTDOOR UNIT FUNCTIONAL PARTS AND STRUCTURAL PARTS

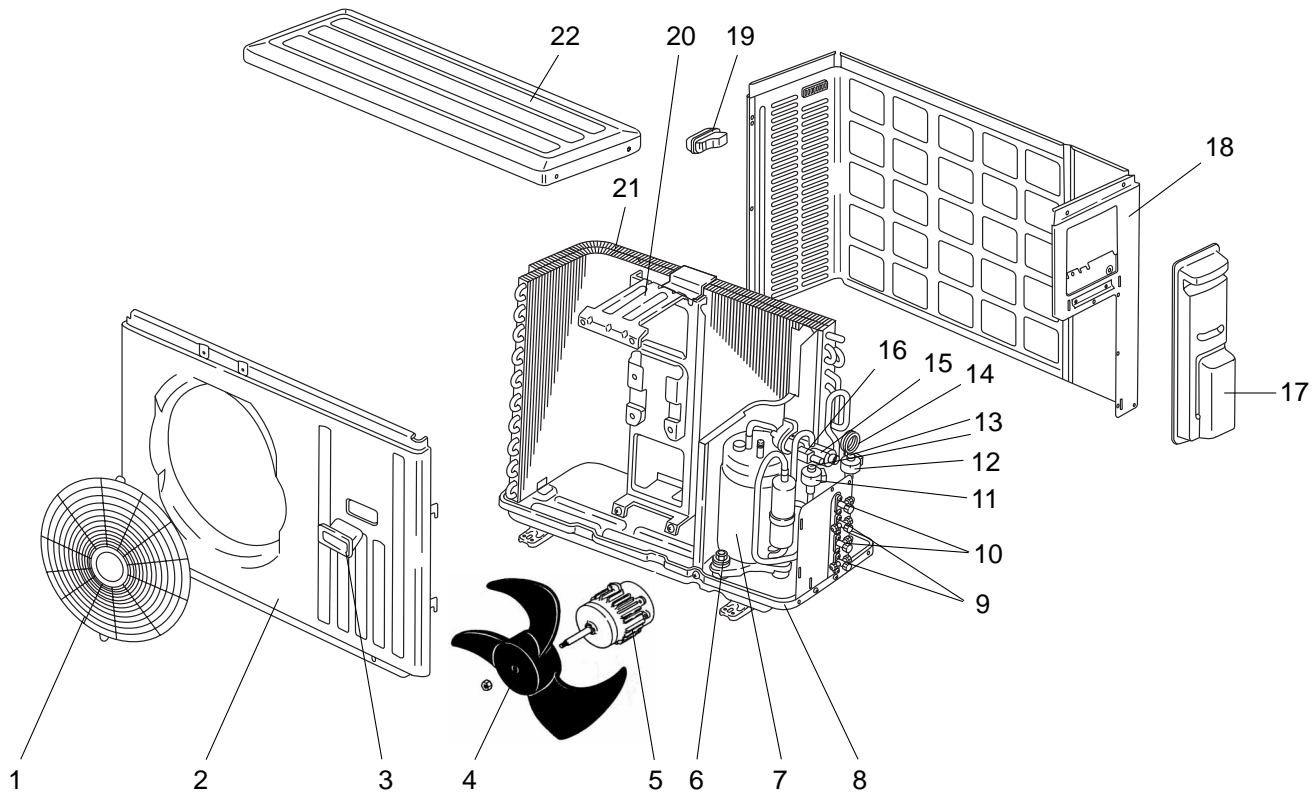

Part numbers that are circled are not shown in the illustration.

No.	Parts No.	Parts Name	Symbol in Wiring Diagram	Q'ty/unit		Remarks
				MXZ- A14WV- <u>E1</u>	MXZ- A18WV- <u>E1</u>	
1	E02 819 521	FAN GUARD		1	1	
2	E02 737 232	CABINET		1	1	
3	E02 819 009	HANDLE		1	1	
4	E02 214 501	PROPELLER		1	1	
5	E02 735 301	OUTDOOR FAN MOTOR	MF	1	1	RA6V49-□□
6	E02 065 506	COMPRESSOR RUBBER SET		3	3	3RUBBERS/SET
7	E02 735 900	COMPRESSOR	MC	1	1	SNV-092FJYH
8	E02 737 290	BASE		1	1	
9	E02 735 661	STOP VALVE (GAS)		2	2	
10	E02 735 662	STOP VALVE (LIQUID)		2	2	
11	E02 736 493	LEV COIL	B	1	1	
12	E02 735 493	LEV COIL	A	1	1	
13	E02 735 640	EXPANSION VALVE	LEV A,B	2	2	
14	E02 735 937	CAPILLARY TUBE		1	1	φ1.8×φ0.6×750
15	E02 735 961	4-WAY VALVE		1	1	
16	E02 735 490	R.V. COIL	21S4	1	1	
17	E02 737 245	SERVICE PANEL		1	1	
18	E02 737 233	BACK PANEL (OUT)		1	1	
19	E02 817 009	HANDLE		1	1	
20	E02 636 515	MOTOR SUPPORT		1	1	
21	E02 735 630	OUTDOOR HEAT EXCHANGER		1	1	
22	E02 819 297	TOP PANEL		1	1	
23	E02 735 933	MUFFLER		2	2	
24	E02 069 936	CAPILLARY TUBE		2	2	φ3.0×φ2.0×400
25	E02 735 936	CAPILLARY TUBE		2	2	φ3.0×φ1.8×600

MXZ-A14WV -E1

MXZ-A18WV -E1

14-2. OUTDOOR UNIT ELECTRICAL PARTS

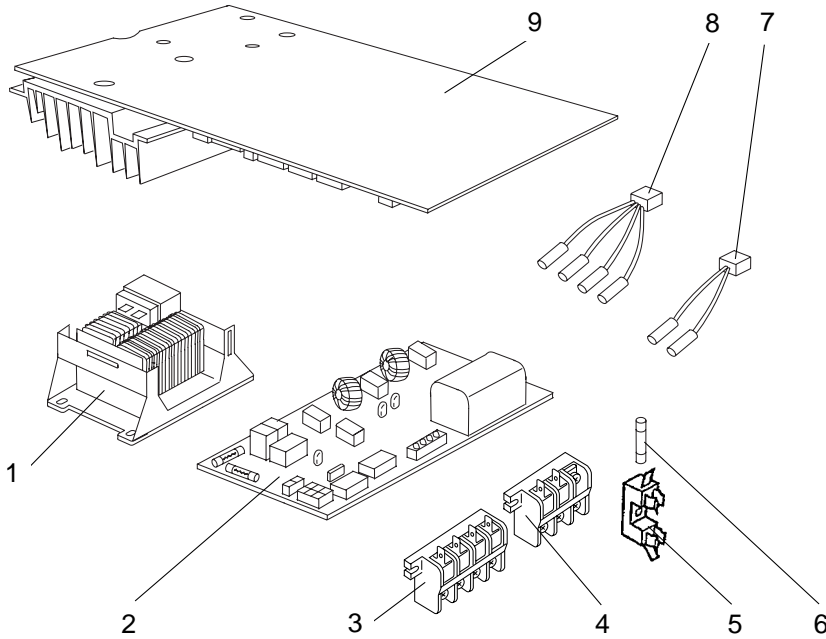

14-3. ACCESSORY

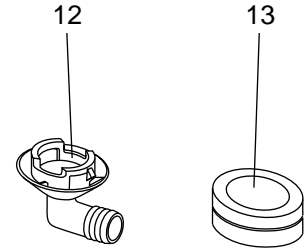

14-2. OUTDOOR UNIT ELECTRICAL PARTS

Part numbers that are circled are not shown in the illustration.

No.	Parts No.	Parts Name	Symbol in Wiring Diagram	Q'ty/unit		Remarks
				MXZ-A14WV-E1	MXZ-A18WV-E1	
1	E02 735 337	REACTOR	L	1	1	
2	E02 735 444	NOISE FILTER P.C. BOARD		1	1	
3	E02 735 374	TERMINAL BLOCK	TB2	1	1	
4	E02 573 375	TERMINAL BLOCK	TB1	1	1	
5	E02 735 241	FUSE HOLDER		1	1	
6	E02 735 382	FUSE	F61	1	1	20A 250VAC
7	E02 735 306	GAS PIPE TEMPERATURE THERMISTOR SET	RT6A,RT6B	1	1	
8	E02 735 308	THERMISTOR SET	RT61,RT62,RT63,RT68	1	1	DISCHARGE,DEFROST EVAPORATOR,HIGH-PRESSURE PROTECT
9	E02 887 450	ELECTRONIC CONTROL P.C. BOARD		1		Including heat sink and RT65
	E02 735 450	ELECTRONIC CONTROL P.C. BOARD			1	Including heat sink and RT65
⑩	E02 735 385	FUSE&VARISTOR	F912,NR63	1	1	3.15A 250V
⑪	E02 737 382	FUSE	F801,F911	1	1	1A 250V

14-3. ACCESSORY

12	E02 817 704	DRAIN SOCKET		1	1	
13	E02 444 705	DRAIN CAP		2	2	2PCS/SET

MXZ-A26WV -E1

MXZ-A32WV -E1

14-4. OUTDOOR UNIT STRUCTURAL PARTS AND FUNCTIONAL PARTS

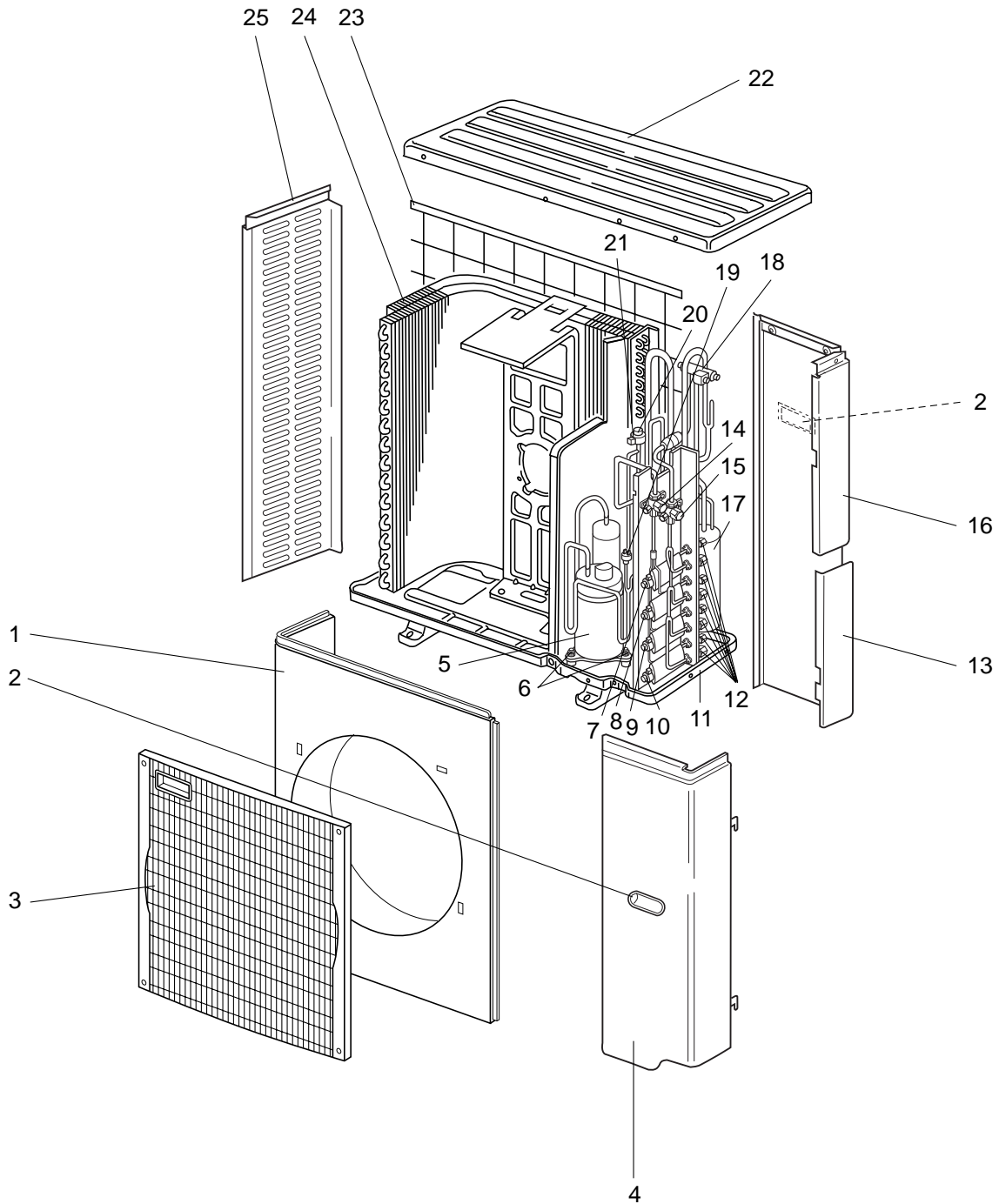

14-4. OUTDOOR UNIT STRUCTURAL PARTS AND FUNCTIONAL PARTS

Part numbers that are circled are not shown in the illustration.

No.	Parts No.	Parts Name	Symbol in Wiring Diagram	Q'ty/unit		Remarks
				MXZ-A26WV- E1	MXZ-A32WV- E1	
1	M21 TK0 232	FRONT PANLE		1	1	
2	M21 TK0 027	HANDLE ASSEMBLY		2	2	
3	M21 TK5 010	GRILLE		1	1	
4	M21 TK0 245	SERVICE PANEL		1	1	
5	T92 500 801	COMPRESSOR	MC	1	1	TNB220FMCH
6	T2W TK0 505	COMPRESSOR RUBBER SET		3	3	3RUBBERS SET
7	M21 TK5 646	EXPANSION VALVE	LEV D		1	D room
	T2W TK0 654	LEV COIL			1	D room
8	M21 TK5 646	EXPANSION VALVE	LEV C	1	1	C room
	T2W TK0 653	LEV COIL		1	1	C room
9	R01 E39 401	EXPANSION VALVE	LEV B	1	1	B room
	T2W TK0 652	LEV COIL		1	1	B room
10	R01 E39 401	EXPANSION VALVE	LEV A	1	1	A room
	T2W TK0 651	LEV COIL		1	1	A room
11	M21 TK0 290	BASE ASSEMBLY		1	1	
12	M21 42E 644	UNION		1	1	1/2,3/8,1/4 SET
13	T2W TK0 247	PIPE COVER		1	1	
14	M21 TK5 667	BALL VALVE 3/8		1	1	
15	M21 TK0 667	BALL VALVE 5/8		1	1	
16	M21 TK0 248	REAR PANEL		1	1	
17	T2W TK0 959	POWER RECEIVER		1	1	
18	M21 20A 961	4-WAY VALVE		1	1	
19	M21 NT1 646	HIGH PRESSURE SWICH	HPS	1	1	4.8MPa(48.9kg/cm ²)
20	T2W WW8 401	EXPANSION VALVE	LEV E	1	1	
21	T2W TK0 651	LEV COIL	LEV E	1	1	
22	M21 TK0 297	TOP PANEL		1	1	
23	T2W E40 523	REAR GUARD		1	1	
24	M21 TK0 630	HEAT EXCHANGER		1	1	
25	M21 TK0 249	SIDE PANEL		1	1	
②6	M21 SJ4 937	CAPILLARY TUBE		2	2	φ4.0×φ2.4×400
②7	M21 TK0 936	CAPILLARY TUBE SET		3	4	φ4.0×φ2.8×90
②8	T2W E59 936	CAPILLARY TUBE		1	1	φ2.5×φ0.6×1000
②9	T2W E70 936	CAPILLARY TUBE		1	1	φ2.0×φ0.6×750

MXZ-A26WV -E1

MXZ-A32WV -E1

14-5. OUTDOOR UNIT FUNCTIONAL PARTS AND ELECTRICAL PARTS

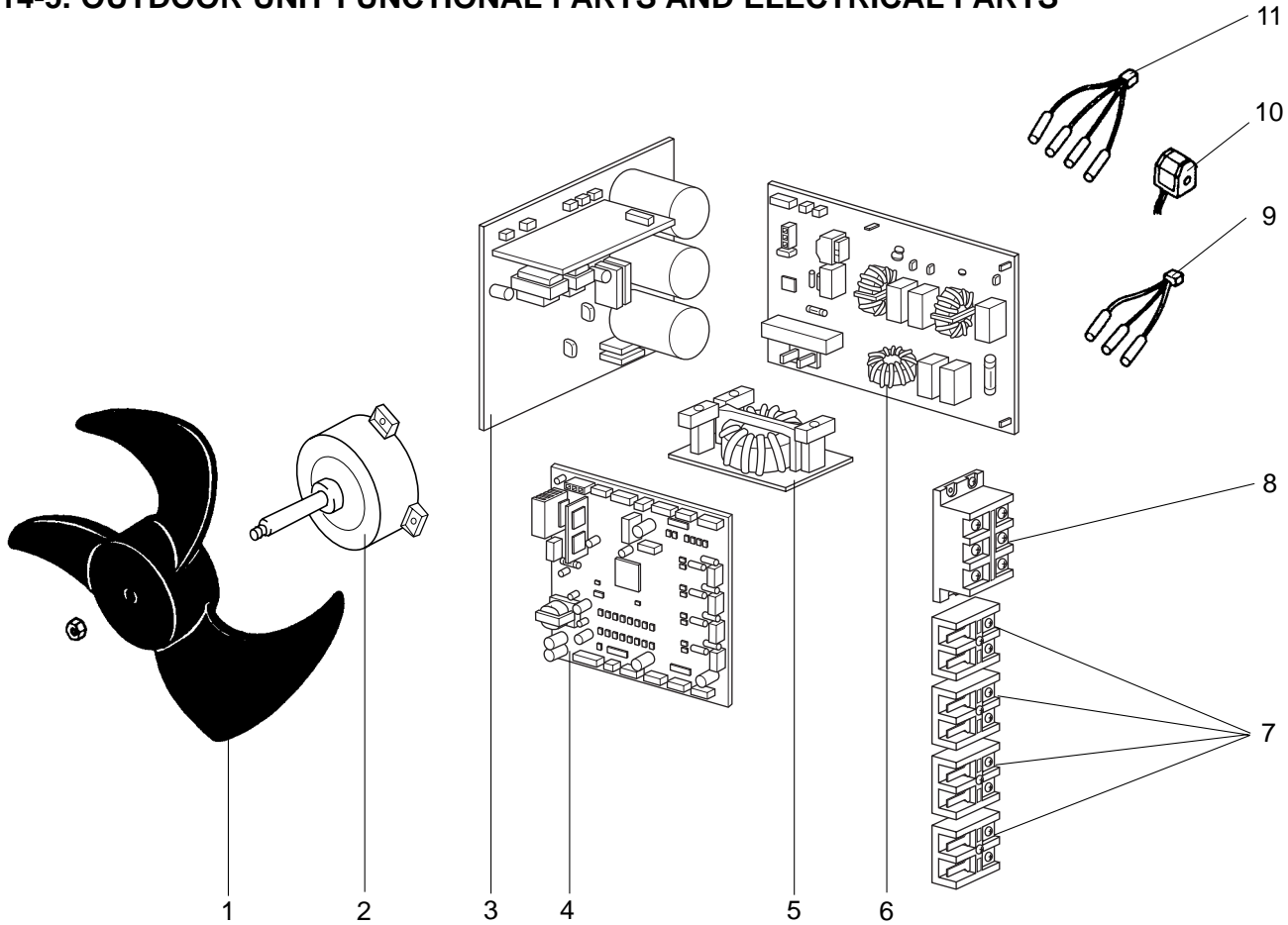

Part numbers that are circled are not shown in the illustration.

No.	Parts No.	Parts Name	Symbol in Wiring Diagram	Q'ty/unit		Remarks
				MXZ-A26WV- E1	MXZ-A32WV- E1	
1	M21 TK0 501	PROPELLER		1	1	
2	M21 TK0 301	OUTDOOR FAN MOTOR	MF	1	1	PM8H60-□□
3	T2W TK0 440	POWER BOARD		1	1	Including heat sink and RT65
4	T2W TK1 451	ELECTRONIC CONTROL P.C. BOARD		1		
	T2W TK0 451	ELECTRONIC CONTROL P.C. BOARD			1	
5	M21 TK0 337	REACTOR	L	1	1	220 μ F 400V
6	T2W TK0 424	NOISE FILTER P.C. BOARD		1	1	
7	T2W E58 376	TERMINAL BLOCK	TB2~5	3	4	Indoor unit connecting
8	T2W TK0 375	TERMINAL BLOCK	TB1	1	1	Power supply
9	T2W E88 307	GAS PIPE TEMPERATURE THERMISTOR	RT6A,B,C	1		
	T2W E70 307	GAS PIPE TEMPERATURE THERMISTOR	RT6A,B,C,D		1	
10	T2W TK0 398	R.V. COIL	21S4	1	1	
11	M21 TK0 308	THERMISTOR SET	RT61,62,63,68	1	1	DISCHARGE, DEFROST EVAPORATION, OUTDOOR HEAT EXCHANGER
12	T2W E08 381	FUSE	F801	1	1	3.15A 250V
13	T2W E66 382	FUSE	F911	1	1	1A 250V
14	T2W E89 313	FUSE&VARISTOR SET	F912,NR63	1	1	3.15A 250V

MXZ-A26WV-^{E1}
MXZ-A32WV-^{E1}
14-6. ACCESSORY

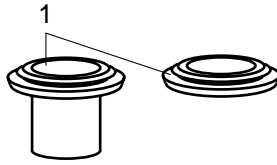

No.	Parts No.	Parts Name	Symbol in Wiring Diagram	Q'ty/unit		Remarks
				MXZ-A26WV- ^{E1}	MXZ-A32WV- ^{E1}	
1	T2W E59 704	DRAIN SOCKET ASSEMBLY		1	1	DRAIN SOCKET x1 DRAIN CAP x2

15 OPTIONAL PARTS

15-1. Different-diameter pipe

MXZ-A14WV MXZ-A18WV	Model name	Connected pipes diameter (mm)	Length A	Length B	Length C
For different-diameter pipes	MAC-A454JP	φ9.52 — φ12.7 (3/8) (1/2)	φ9.52 (3/8)	φ12.7 (1/2)	69

MXZ-A26WV MXZ-A32WV	Model name	Connected pipes diameter (mm)	Length A	Length B	Length C
For different-diameter pipes	MAC-A454JP	φ9.52 — φ12.7 (3/8) (1/2)	φ9.52 (3/8)	φ12.7 (1/2)	69
	MAC-A455JP	φ12.7 — φ9.52 (1/2) (3/8)	φ12.7 (1/2)	φ9.52 (3/8)	65
	MAC-A456JP	φ12.7 — φ15.88 (1/2) (5/8)	φ12.7 (1/2)	φ15.88 (5/8)	66.5

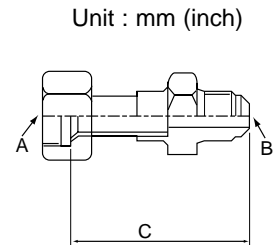

15-2. Outlet guide

Changes air discharge direction.

Applied unit	Model name	Model code
MXZ-A26WV MXZ-A32WV	MAC-855SG	51H-855

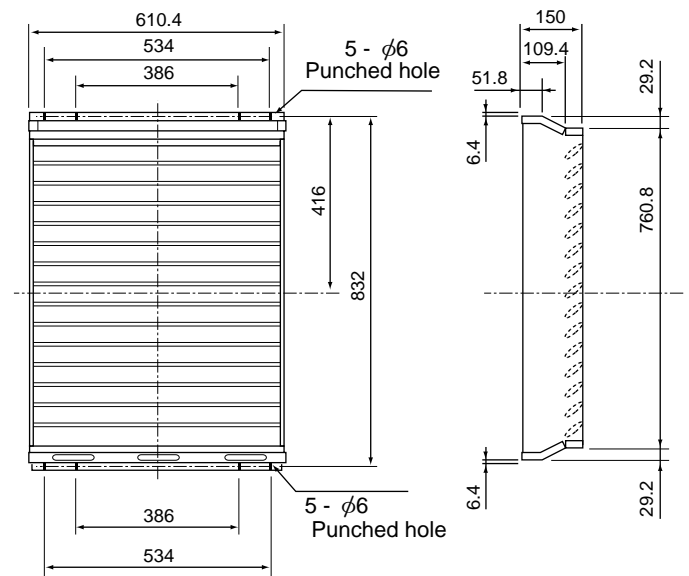

MAC-855SG



HEAD OFFICE: MITSUBISHI DENKI BLDG.,2-2-3, MARUNOUCHI, CHIYODA-KU, TOKYO100-8310, JAPAN

© Copyright 2004 MITSUBISHI ELECTRIC ENGINEERING CO.,LTD
Distributed in Aug. 2004. No.OB319 REVISED EDITION-A 8
Distributed in Dec. 2003. No.OB319 7
Made in Japan

New publication, effective Aug. 2004
Specifications subject to change without notice.