

Revision B:

- The fan guard for MUCFH-GA 60VB-**E1** has been changed.

Please void OB381 REVISED EDITION-A.

OUTDOOR UNIT SERVICE MANUAL



**No. OB381
REVISED EDITION-B**

Models

MUCFH-GA35VB - **E1**

MUCFH-GA50VB - **E1**

MUCFH-GA60VB - **E1**

Indoor unit service manual
MCFH-GA·VB Series (OB380)

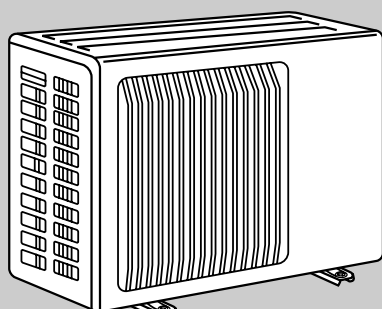

MUCFH-GA50VB

CONTENTS

1. TECHNICAL CHANGES	2
2. PART NAMES AND FUNCTIONS	5
3. SPECIFICATION	6
4. NOISE CRITERIA CURVES	7
5. OUTLINES AND DIMENSIONS	8
6. WIRING DIAGRAM	10
7. REFRIGERANT SYSTEM DIAGRAM	11
8. PERFORMANCE CURVES	13
9. ACTUATOR CONTROL	24
10. SERVICE FUNCTIONS	24
11. TROUBLESHOOTING	25
12. DISASSEMBLY INSTRUCTIONS	35
13. PARTS LIST	42
14. RoHS PARTS LIST	48

NOTE:

This service manual describes technical data of the outdoor units.
RoHS compliant products have <G> mark on the spec name plate.
For servicing of RoHS compliant products, refer to the RoHS PARTS LIST (RoHS compliant).



Revision A :

- RoHS PARTS LIST has been added.

Revision B :

- The fan guard for MUCFH-GA 60VB-^[E1] has been changed.

1 TECHNICAL CHANGES

MUH-A12YV -^[E1] → MUCFH-GA35VB -^[E1]

1. Indication of capacity has been changed. (BTU base → kW)

MUCFH-A18WV -^[E1] → MUCFH-GA50VB -^[E1]

1. Indication of capacity has been changed. (BTU base → kW)

MUCFH-A24WV -^[E1] → MUCFH-GA60VB -^[E1]

1. Indication of capacity has been changed. (BTU base → kW)

INFORMATION FOR THE AIR CONDITIONER WITH R410A REFRIGERANT

- This room air conditioner adopts HFC refrigerant (R410A) which never destroys the ozone layer.
 - Pay particular attention to the following points, though the basic installation procedure is same as that for R22 conditioners.
- ① As R410A has working pressure approximate 1.6 times as high as that of R22, some special tools and piping parts/materials are required. Refer to the table below.
 - ② Take sufficient care not to allow water and other contaminations to enter the R410A refrigerant during storage and installation, since it is more susceptible to contaminations than R22.
 - ③ For refrigerant piping, use clean, pressure-proof parts/materials specifically designed for R410A. (Refer to 2. Refrigerant piping.)
 - ④ Composition change may occur in R410A since it is a mixed refrigerant. When charging, charge liquid refrigerant to prevent composition change.

		New refrigerant	Previous refrigerant
Refrigerant	Refrigerant	R410A	R22
	Composition (Ratio)	HFC-32: HFC-125 (50%:50%)	R22 (100%)
	Refrigerant handling	Pseudo-azeotropic refrigerant	Single refrigerant
	Chlorine	Not included	Included
	Safety group (ASHRAE)	A1/A1	A1
	Molecular weight	72.6	86.5
	Boiling point (°C)	-51.4	-40.8
	Steam pressure [25°C](Mpa)	1.557	0.94
	Saturated steam density [25°C](Kg/m³)	64	44.4
	Combustibility	Non combustible	Non combustible
	ODP ※1	0	0.055
	GWP ※2	1730	1700
	Refrigerant charge method	From liquid phase in cylinder	Gas phase
	Additional charge on leakage	Possible	Possible
Refrigeration oil	Kind	Incompatible oil	Compatible oil
	Color	Non	Light yellow
	Smell	Non	Non

※1 :Ozone Destruction Parameter : based on CFC-11

※2 :Global Warmth Parameter : based on CO₂

	New Specification	Current Specification
Compressor	<p>The incompatible refrigeration oil easily separates from refrigerant and is in the upper layer inside the suction muffler. Raising position of the oil back hole enables to back the refrigeration oil of the upper layer to flow back to the compressor.</p>	<p>Since refrigerant and refrigerating oil are compatible each, refrigeration oil goes back to the compressor through the lower position oil back hole.</p>

NOTE : The unit of pressure has been changed to MPa on the international system of units(SI unit system).
The conversion factor is: **1(MPa [Gauge]) =10.2(kgf/cm² [Gauge])**

Conversion chart of refrigerant temperature and pressure

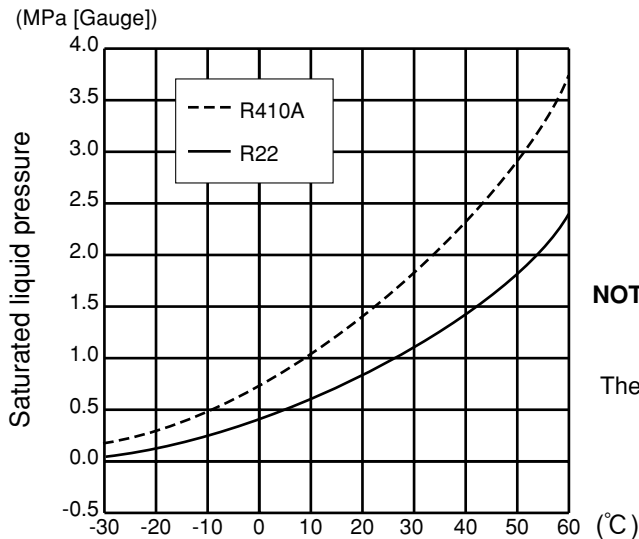

NOTE : The unit of pressure has been changed to MPa on the international system of units(SI unit system).
The conversion factor is: **1(MPa [Gauge]) =10.2(kgf/cm² [Gauge])**

1.Tools dedicated for the air conditioner with R410A refrigerant

The following tools are required for R410A refrigerant. Some R22 tools can be substituted for R410A tools. The diameter of the service port on the stop valve in outdoor unit has been changed to prevent any other refrigerant being charged into the unit. Cap size has been changed from 7/16 UNF with 20 threads to 1/2 UNF with 20 threads.

R410A tools	Can R22 tools be used?	Description
Gauge manifold	No	R410A has high pressures beyond the measurement range of existing gauges. Port diameters have been changed to prevent any other refrigerant from being charged into the unit.
Charge hose	No	Hose material and cap size have been changed to improve the pressure resistance.
Gas leak detector	No	Dedicated for HFC refrigerant.
Torque wrench	Yes	6.35 mm and 9.52 mm
	No	12.7 mm and 15.88 mm
Flare tool	Yes	Clamp bar hole has been enlarged to reinforce the spring strength in the tool.
Flare gauge	New	Provided for flaring work (to be used with R22 flare tool).
Vacuum pump adapter	New	Provided to prevent the back flow of oil. This adapter enables you to use vacuum pumps.
Electronic scale for refrigerant charging	New	It is difficult to measure R410A with a charging cylinder because the refrigerant bubbles due to high pressure and high-speed vaporization

No : Not Substitutable for R410A Yes : Substitutable for R410A

2.Refrigerant piping

① Specifications

Use the refrigerant pipes that meet the following specifications.

Pipe	Outside diameter	Wall thickness	Insulation material
	mm		
For liquid	6.35	0.8 mm	Heat resisting foam plastic Specific gravity 0.045 Thickness 8 mm
	9.52	0.8 mm	
For gas	12.7	0.8 mm	
	15.88	1.0 mm	

- Use a copper pipe or a copper-alloy seamless pipe with a thickness of 0.8 mm (6.35, 9.52, 12.7), 1.0 mm (15.88). Never use any pipe with a thickness less than 0.8 mm (6.35, 9.52, 12.7), 1.0 mm (15.88), as the pressure resistance is insufficient.

② Flaring work and flare nut

Flaring work for R410A pipe differs from that for R22 pipe.

For details of flaring work, refer to Installation manual "FLARING WORK".

Pipe diameter mm	Dimension of flare nut	
	R410A	R22
6.35	17	17
9.52	22	22
12.7	26	24
15.88	29	27

3.Refrigerant oil

Apply the special refrigeration oil (accessories: packed with indoor unit) to the flare and the union seat surfaces.

4.Air purge

- Do not discharge the refrigerant into the atmosphere. Take care not to discharge refrigerant into the atmosphere during installation, reinstallation, or repairs to the refrigerant circuit.
- Use the vacuum pump for air purging for the purpose of environmental protection.

5.Additional charge

For additional charging, charge the refrigerant from liquid phase of the gas cylinder.

If the refrigerant is charged from the gas phase, composition change may occur in the refrigerant inside the cylinder and the outdoor unit. In this case, ability of the refrigeration cycle decreases or normal operation can be impossible. However, charging the liquid refrigerant all at once may cause the compressor to be locked. Thus, charge the refrigerant slowly.

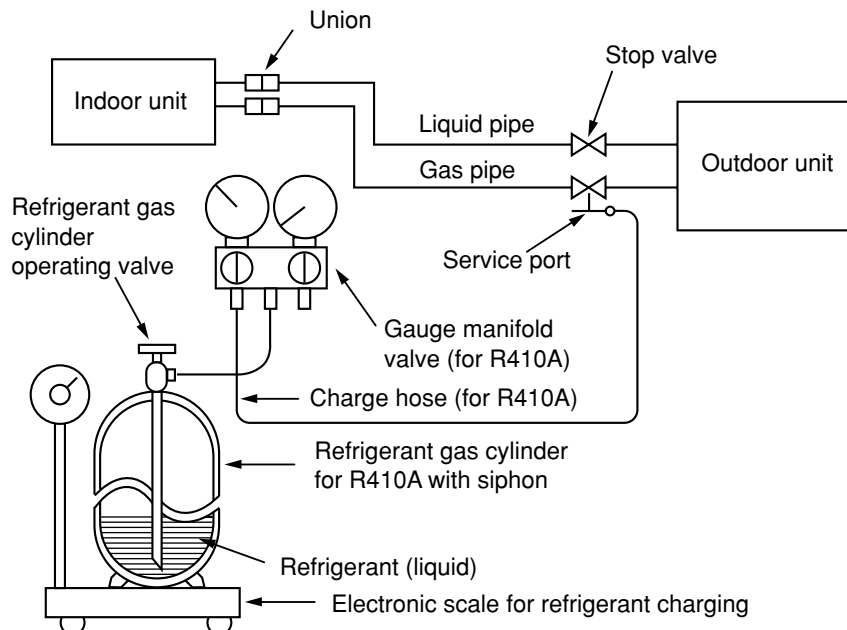

MUCFH-GA35VB

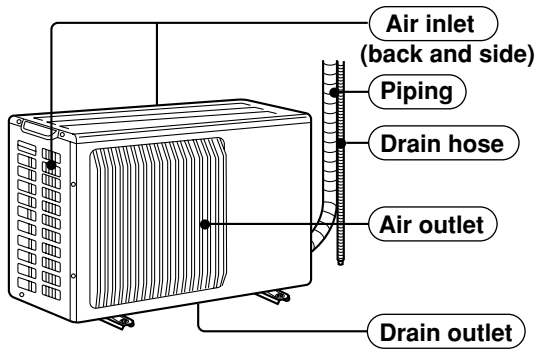

MUCFH-GA50VB

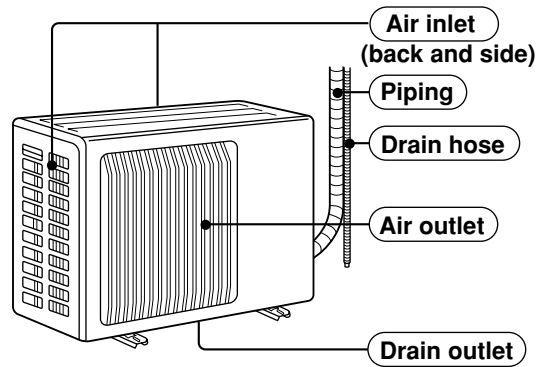

MUCFH-GA60VB

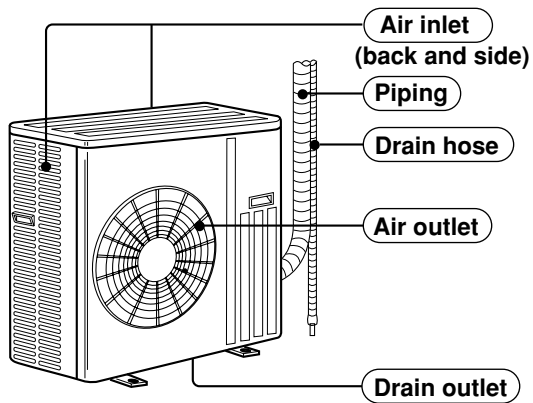

ACCESSORIES

	Item	Q'ty		
		MUCFH-GA35VB	MUCFH-GA50VB	MUCFH-GA60VB
①	Drain socket	1	1	1
②	Drain cap ϕ 33	2	2	2
③	Drain cap ϕ 16	-	1	-

3

SPECIFICATION

Outdoor model			MUCFH-GA35VB		MUCFH-GA50VB		MUCFH-GA60VB	
Function			Cooling	Heating	Cooling	Heating	Cooling	Heating
Power supply			Single phase 230V, 50Hz		Single phase 230V, 50Hz		Single phase 230V, 50Hz	
Capacity	Capacity	kW	3.5	3.7	4.8	5.0	6.0	6.8
	Dehumidification	ℓ /h	1.5	—	2.4	—	3.1	—
	Air flow(High)	m³ /h	1,710		2,196		2,760	
Electrical data	Power outlet	A	10		15		25	
	Running current	A	4.85	4.23	8.01	8.38	10.51	11.71
	Power input	W	1,094	954	1,730	1,810	2,370	2,640
	Power factor	%	98		94		98	
	Starting current	A	29		37		74	
	Compressor motor current	A	4.54	3.92	7.62	7.99	9.93	11.13
	Fan motor current	A	0.31		0.39		0.58	
	Coefficient of performance(C.O.P)			3.02	3.63	2.65	2.65	2.45
Compressor	Model		RN135VHSHT		RN196VHSHT		NN29VBAHT	
	Output	W	900		1,300		1,900	
	Winding resistance(at 20°C)	Ω	C-R 2.79 C-S 3.36		C-R 1.80 C-S 3.00		C-R 0.80 C-S 1.64	
Fan motor	Model		RA6V33-JB		RA6V50-PA		RA6V85-DA	
	Winding resistance(at 20°C)	Ω	WHT-BLK 215.1 BLK-RED 306.9		WHT-BLK 79.5 BLK-RED 83.0		WHT-BLK 68.8 BLK-RED 93.1	
Dimensions W×H×D			780×540×255		850×605×290		840×850×330	
Weight			40		47		74	
Special remarks	Sound level(High)	dB	49		52		53	
	Fan speed(High)	rpm	825		828		730	
	Fan speed regulator		1		1		1	
	Refrigerant filling capacity(R410A)	kg	1.00		1.85		2.20	
	Refrigeration oil (Model)	cc	620 (NEO22)		520 (NEO22)		1,200 (NEO22)	
	Thermistor RT61(at 0°C)	kΩ	33.18		33.18		33.18	

NOTE: Test conditions are based on ISO 5151.

Cooling : Indoor DB27°C WB19°C

Outdoor DB35°C WB(24°C)

Indoor-Outdoor piping length : 5m

Heating : Indoor DB20°C WB 15.5°C

Outdoor DB 7°C WB 6°C

4

NOISE CRITERIA CURVES

MUCFH-GA35VB

FUNCTION	SPL(dB(A))	LINE
COOLING	49	● — ●
HEATING		

Test conditions,

Cooling : Dry-bulb temperature 35°C Wet-bulb temperature (24°C)
 Heating : Dry-bulb temperature 7°C Wet-bulb temperature 6°C

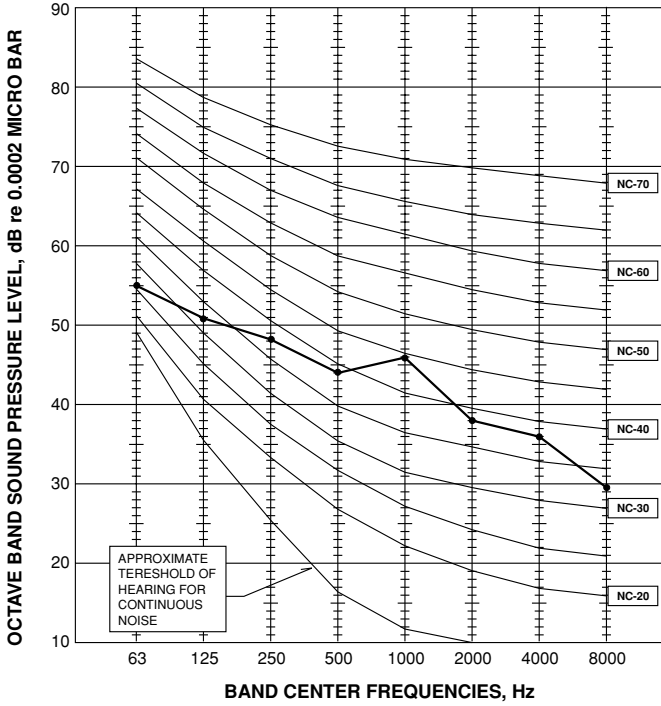

MUCFH-GA50VB

FUNCTION	SPL(dB(A))	LINE
COOLING	52	● — ●
HEATING		

Test conditions,

Cooling : Dry-bulb temperature 35°C Wet-bulb temperature (24°C)
 Heating : Dry-bulb temperature 7°C Wet-bulb temperature 6°C

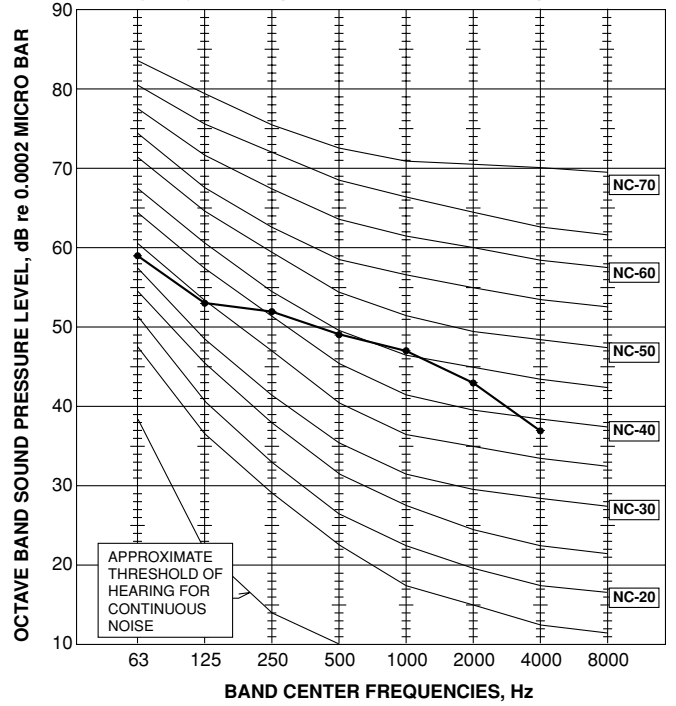

MUCFH-GA60VB

FUNCTION	SPL(dB(A))	LINE
COOLING	53	● — ●
HEATING		

Test conditions,

Cooling : Dry-bulb temperature 35°C Wet-bulb temperature (24°C)
 Heating : Dry-bulb temperature 7°C Wet-bulb temperature 6°C

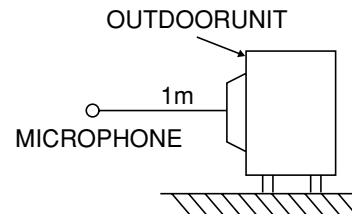
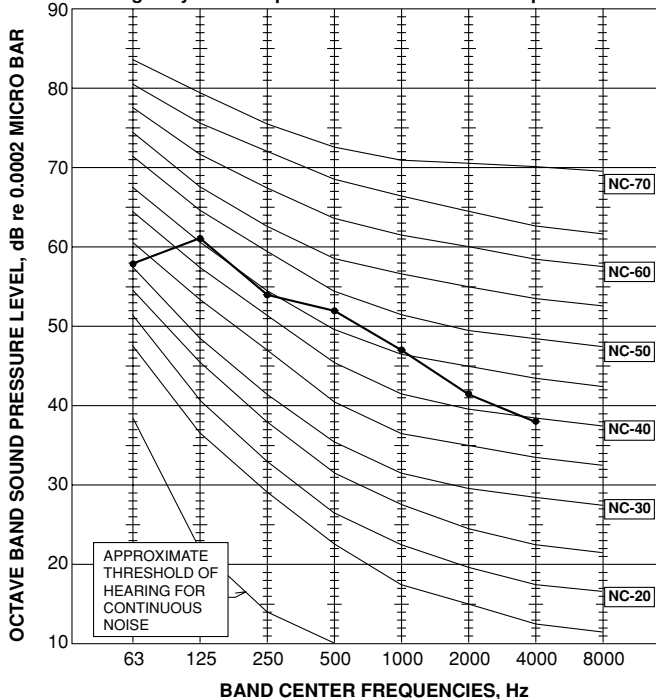

MUCFH-GA35VB

Unit: mm

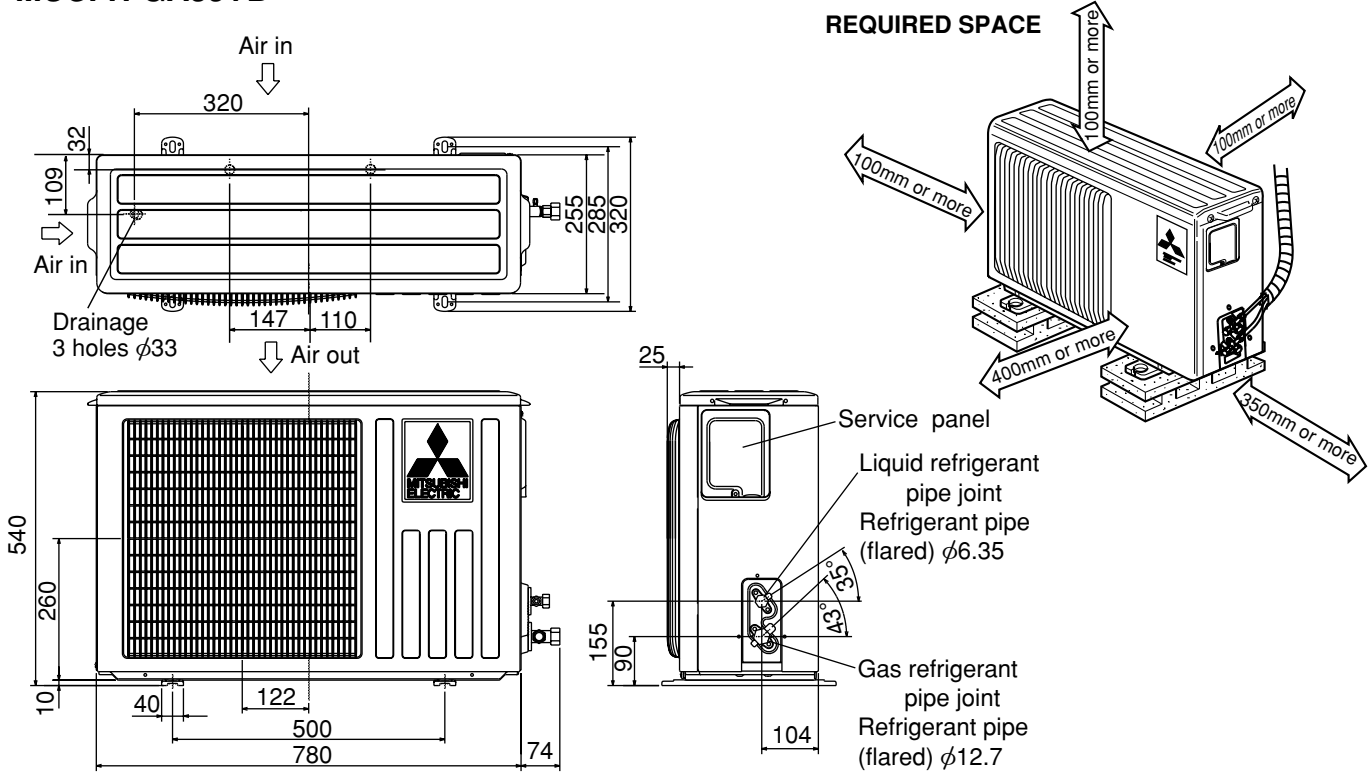

MUCFH-GA50VB

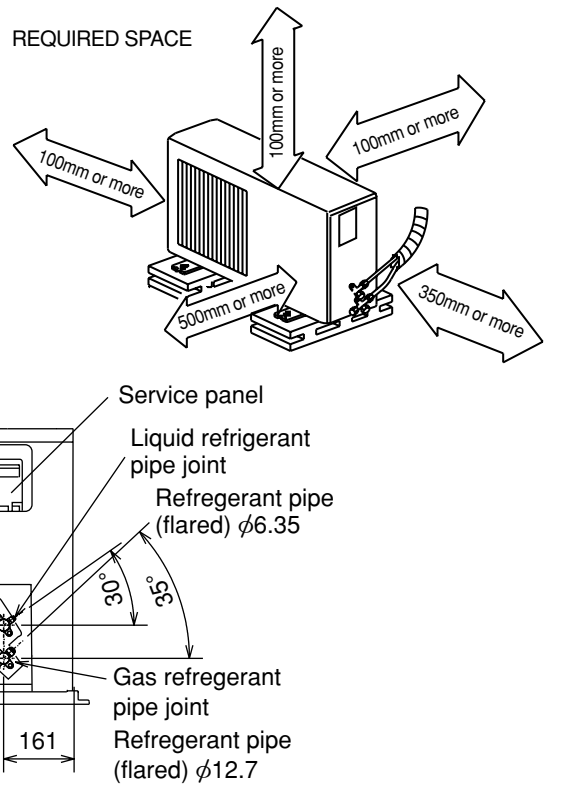

MUCFH-GA60VB

Unit: mm

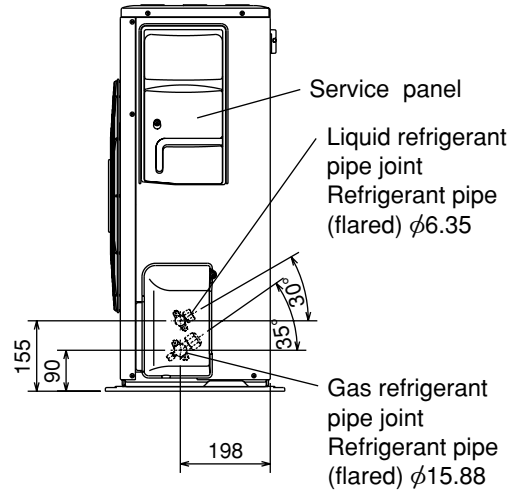
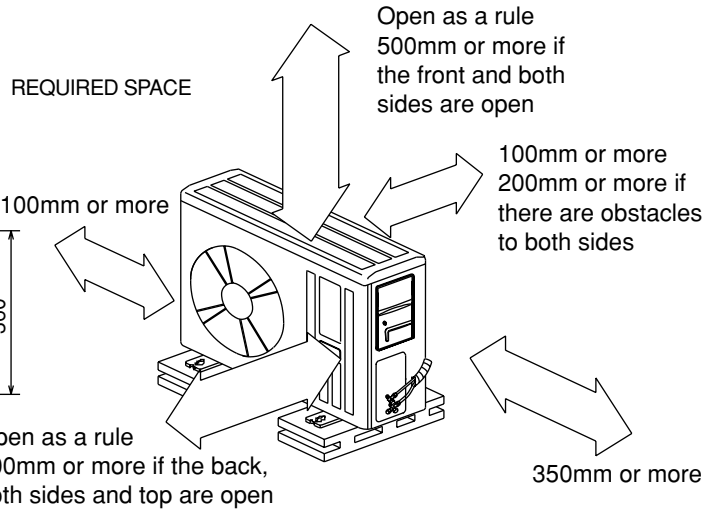
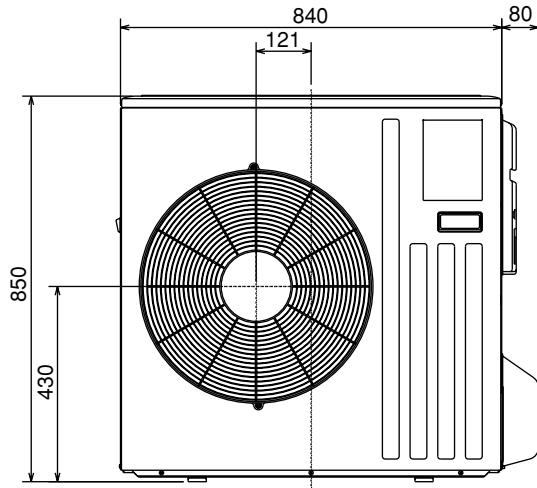
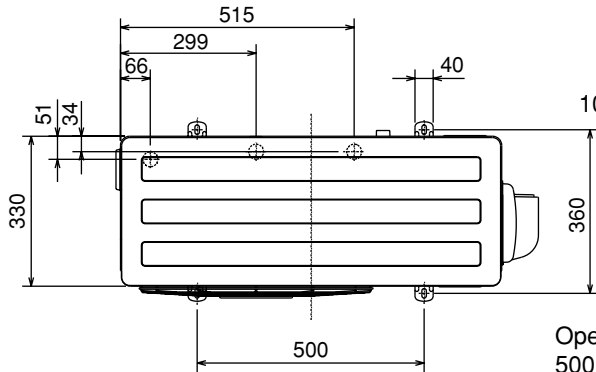

6

WIRING DIAGRAM

MUCFH-GA35VB

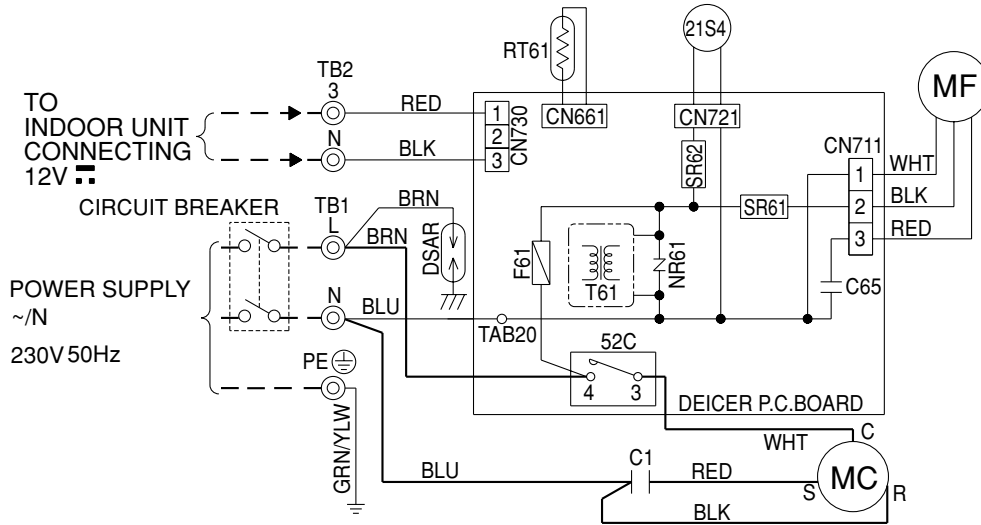

SYMBOL	NAME	SYMBOL	NAME	SYMBOL	NAME
C1	COMPRESSOR CAPACITOR	MF	OUTDOOR FAN MOTOR (INNER FUSE)	T61	TRANSFORMER
C65	OUTDOOR FAN CAPACITOR			TB1, TB2	TERMINAL BLOCK
DSAR	SURGE ABSORBER	NR61	VARISTOR	21S4	R.V. COIL
F61	FUSE(2A)	RT61	DEFROST THERMISTOR	52C	COMPRESSOR CONTACTOR
MC	COMPRESOR(INNER PROTECTOR)	SR61, SR62	SOLID STATE RELAY		

NOTE:1. About the indoor side electric wiring refer to the indoor unit electric wiring diagram for servicing.

2. Use copper conductors only. (For field wiring)

3. Symbols below indicate.

⊙: Terminal block, □□□□: Connector

MUCFH-GA50VB

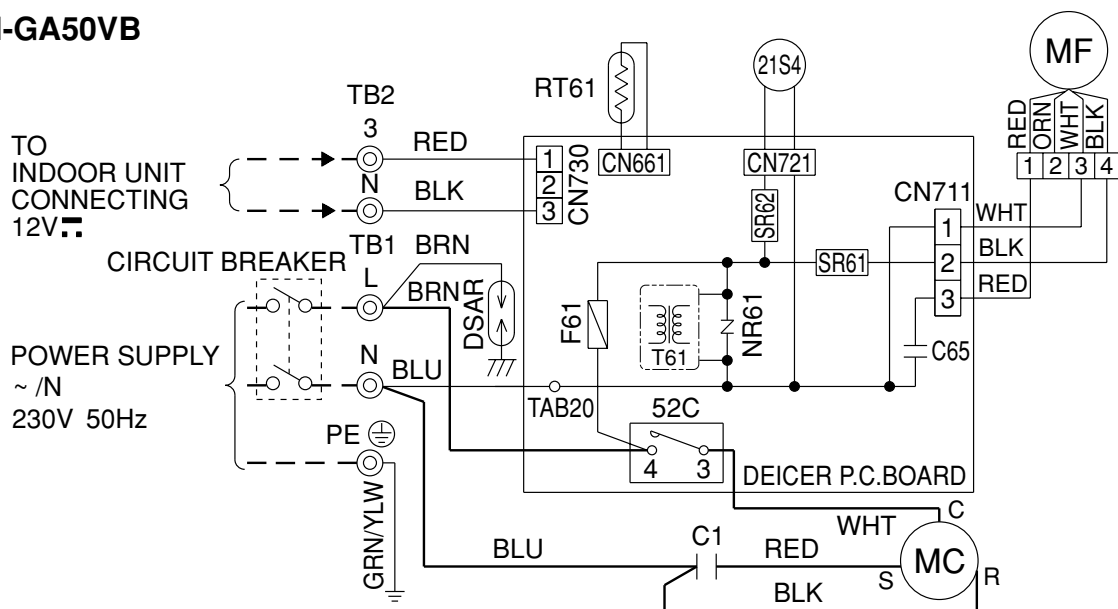

SYMBOL	NAME	SYMBOL	NAME	SYMBOL	NAME
C1	COMPRESSOR CAPACITOR	MF	OUTDOOR FAN MOTOR (INNER PROTECTOR)	TB1, TB2	TERMINAL BLOCK
C65	OUTDOOR FAN CAPACITOR			21S4	R.V. COIL
DSAR	SURGE ABSORBER	NR61	VARISTOR	52C	COMPRESSOR CONTACTOR
F61	FUSE (2A)	RT61	DEFROST THERMISTOR		
MC	COMPRESOR (INNER PROTECTOR)	SR61, SR62	SOLID STATE RELAY	T61	TRANSFORMER

NOTES: 1. About the indoor side electric wiring refer to the indoor unit electric wiring diagram for servicing.

2. Use copper conductors only. (For field wiring)

3. Symbols below indicate.

⊙: Terminal block □□□□: Connector

MUCFH-GA60VB

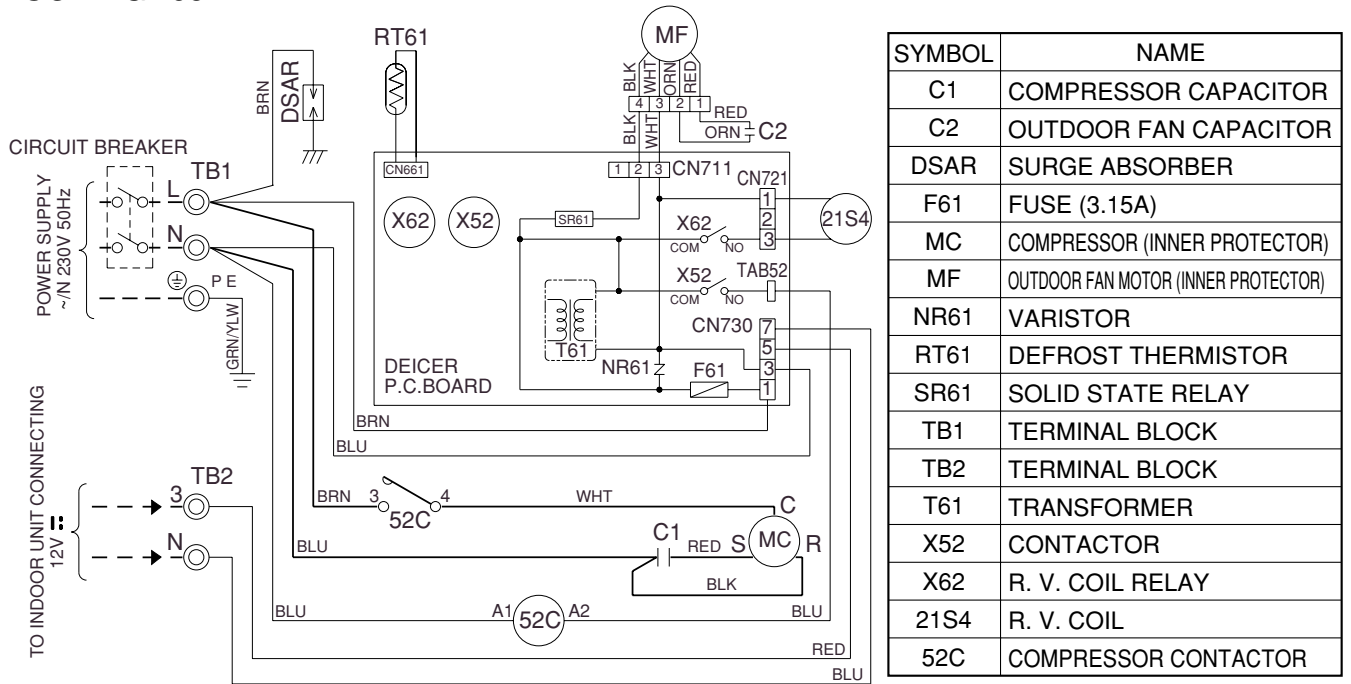

- NOTES: 1. Use copper conductors only (For field wiring).
 2. Since the indoor and outdoor unit connecting wires have polarity, connect them according to the numbers (3,N).
 3. Symbols below indicate.
 ○ : Terminal block, □ : Connector

7

REFRIGERANT SYSTEM DIAGRAM

MUCFH-GA35VB

Unit:mm

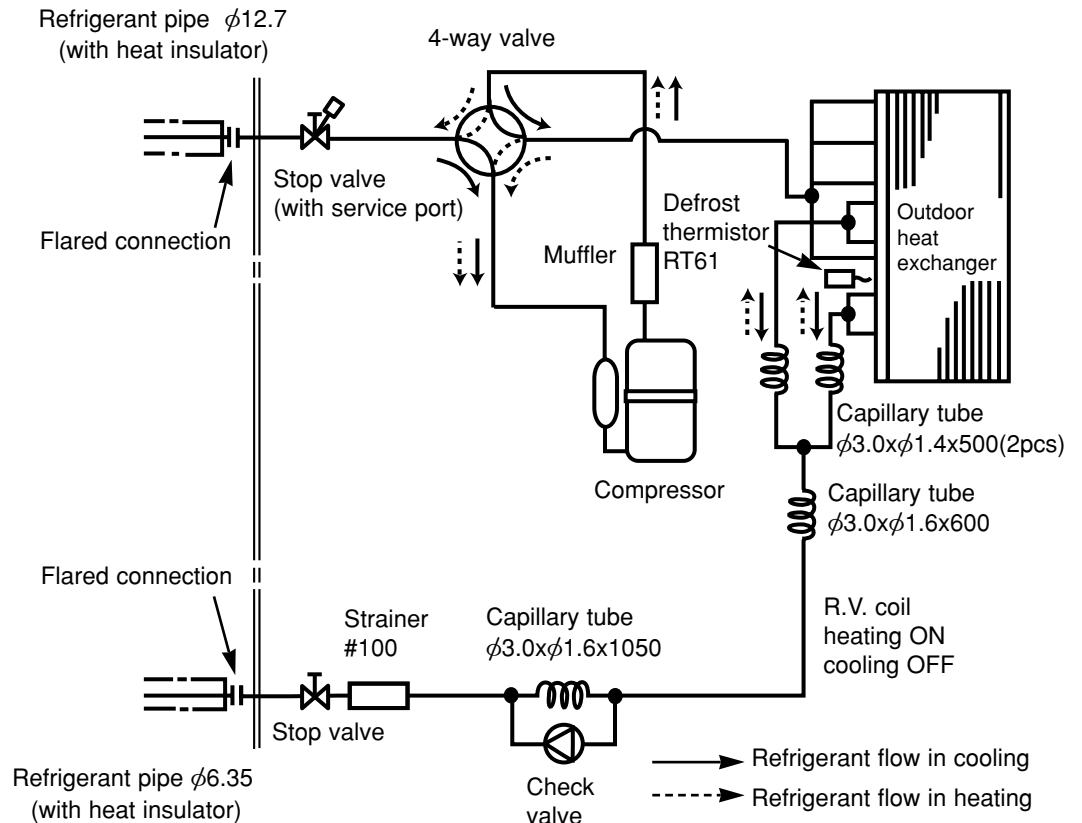

MUCFH-GA50VB

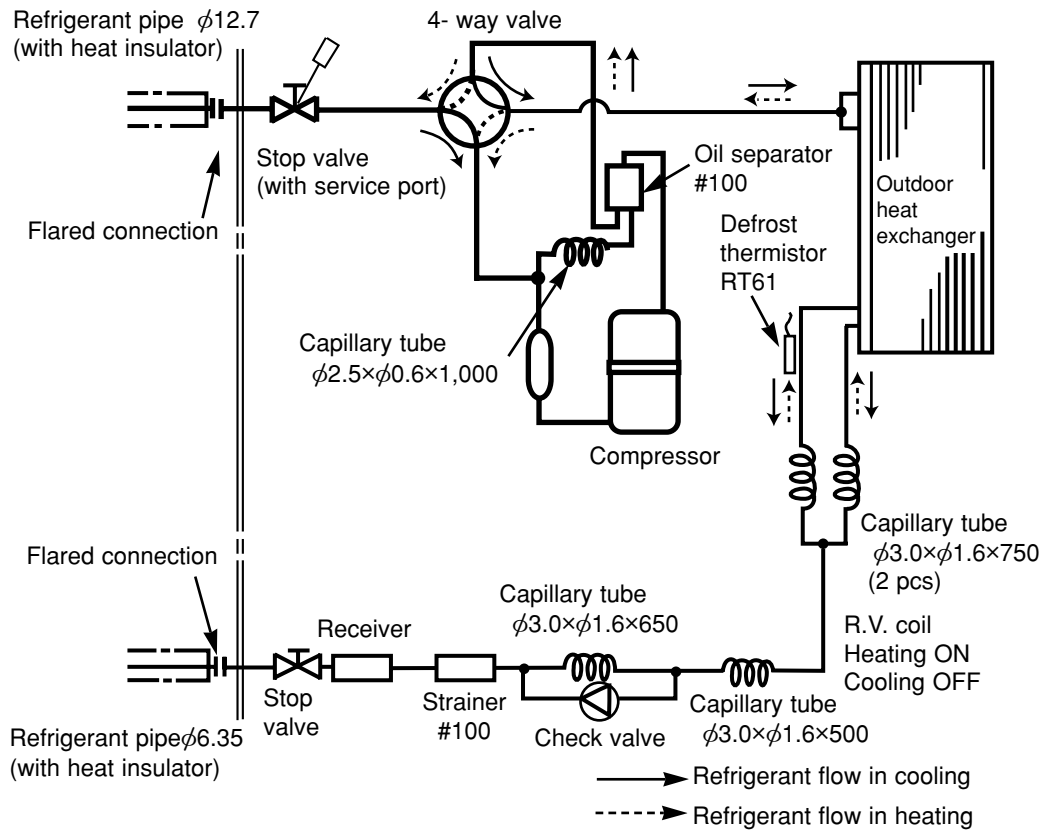

MUCFH-GA60VB

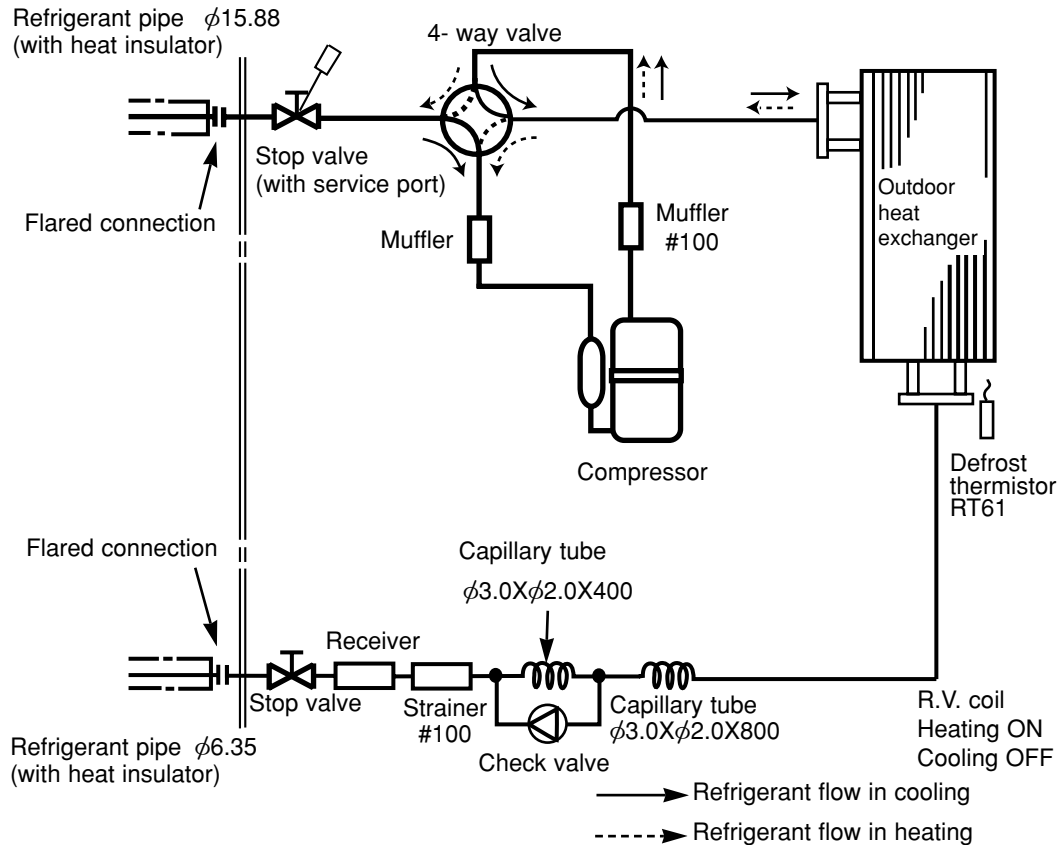

MAX. REFRIGERANT PIPING LENGTH & MAX. HEIGHT DIFFERENCE

Model	Refrigerant piping MAX. length : m A	Piping size O.D. : mm	
		Gas	Liquid
MUCFH-GA35VB	25	φ12.7	φ6.35
MUCFH-GA50VB			
MUCFH-GA60VB		φ15.88	

*It does not matter which unit is higher.

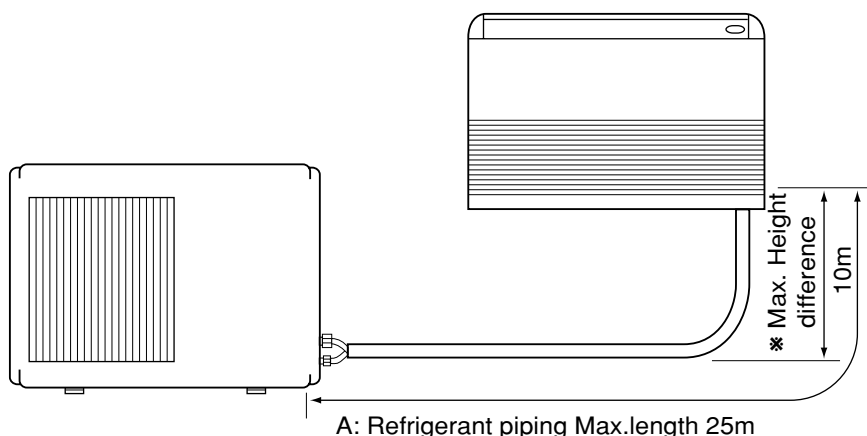

ADDITIONAL REFRIGERANT CHARGE (R410A : g)

If pipe length exceeds 7m, additional refrigerant (R410A) charge is required.

Models	Outdoor unit: precharged	Refrigerant piping length (one way)				
		7m	10m	15m	20m	25m
MUCFH-GA35VB	1,000	0	60	160	260	360
MUCFH-GA50VB	1,850					
MUCFH-GA60VB	2,200					

Calculation : $\times g = 20g/m \times (\text{Refrigerant piping length (m)} - 7)$

8

PERFORMANCE CURVES

MUCFH-GA35VB MUCFH-GA50VB MUCFH-GA60VB

The standard data contained in these specifications apply only to the operation of the air conditioner under normal condition. Operating conditions vary according to the areas where these units are installed. The following information has been provided to clarify the operating characteristics of the air conditioner under the conditions indicated by the performance curve.

(1) GUARANTEED VOLTAGE

198~264V, 50Hz

(2) AIR FLOW

Air flow should be set at MAX.

(3) MAIN READINGS

COOLING

- (1) Indoor intake air wet-bulb temperature : °CWB
- (2) Indoor outlet air wet-bulb temperature : °CWB
- (3) Outdoor intake air dry-bulb temperature : °CDB
- (4) Total input : W

HEATING

- (1) Indoor intake air dry-bulb temperature : °CDB
- (2) Indoor outlet air dry-bulb temperature : °CDB
- (3) Outdoor intake air wet-bulb temperature : °CWB
- (4) Total input : W

Indoor air wet/dry-bulb temperature difference on the left side of the chart on next page shows the difference between the indoor intake air wet/dry-bulb temperature and the indoor outlet air wet/dry-bulb temperature for your reference at service.

How to measure the indoor air wet-bulb/dry-bulb temperature difference

1. Attach at least 2 sets of wet and dry-bulb thermometers to the indoor air inlet as shown in the figure, and at least 2 sets of wet and dry bulb thermometers to the indoor air outlet. The thermometers must be attached to the position where air speed is high.
2. Attach at least 2 sets of wet and dry-bulb thermometers to the outdoor air inlet. Cover the thermometers to prevent direct rays of the sun.
3. Check that the air filter is cleaned.
4. Open windows and doors of the room.
5. Press the EMERGENCY OPERATION switch once(twice) to start the EMERGENCY COOL(HEAT) MODE.
6. When system stabilizes after more than 15 minutes, measure temperature and take an average temperature.
7. 10 minutes later, measure temperature again and check that the temperature does not change.

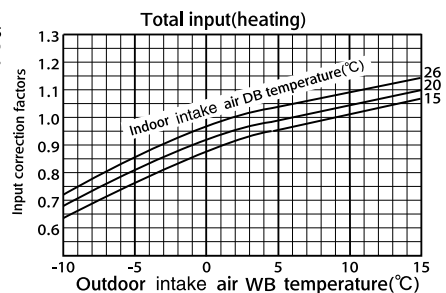
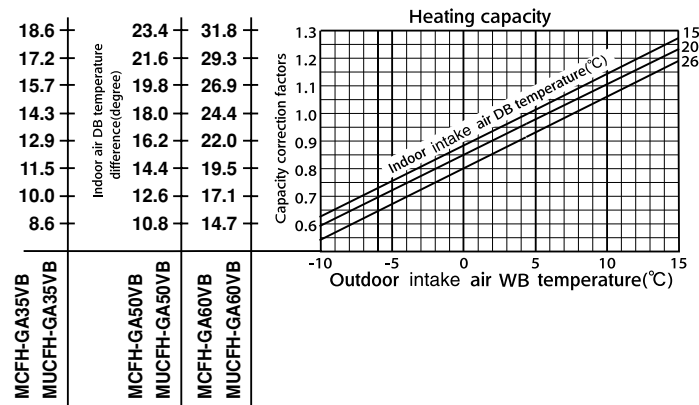
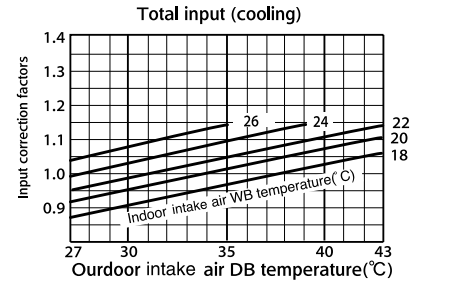
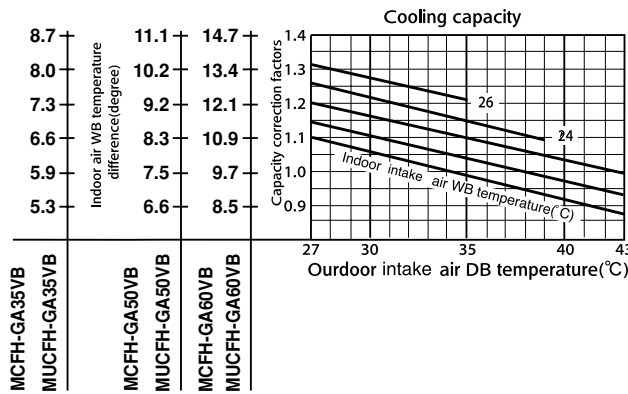
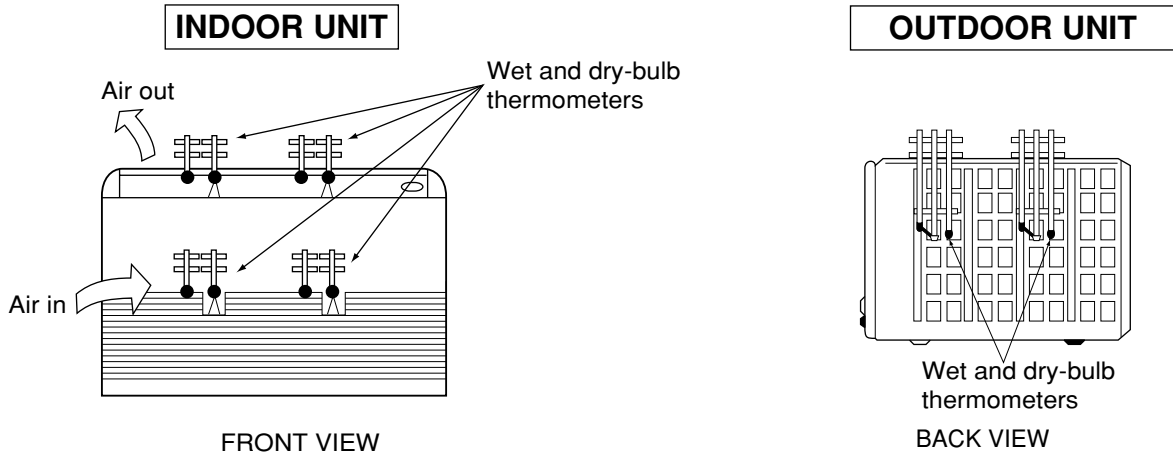

OUTDOOR LOW PRESSURE AND OUTDOOR UNIT CURRENT

COOL operation

① Both indoor and outdoor units are under the same temperature/humidity condition.

Dry Bulb temperature (°C)	Relative humidity (%)
20	50
25	60
30	70

- ② Air flow should be set at MAX.
- ③ The unit of pressure has been changed to MPa on the international system of units(SI unit system).
The conversion factor is : **1(MPa [Gauge]) =10.2(kgf/cm² [Gauge])**

MUCFH-GA35VB

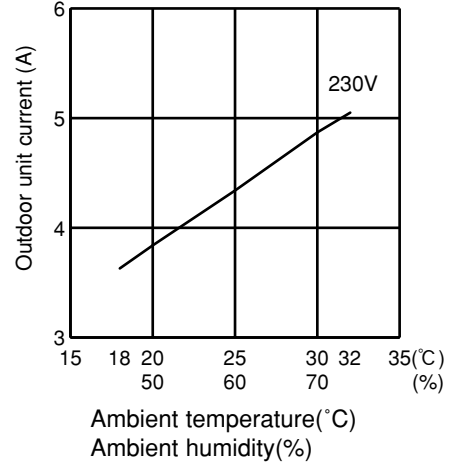
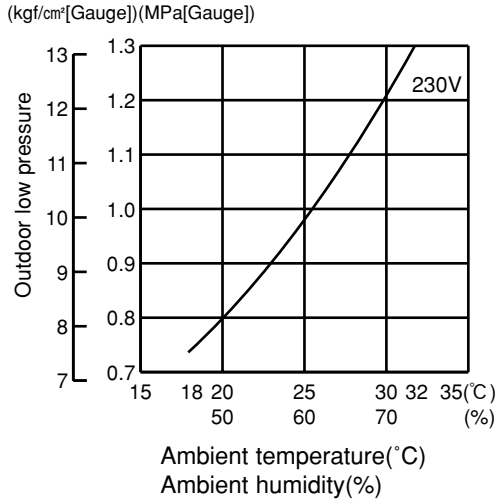

MUCFH-GA50VB

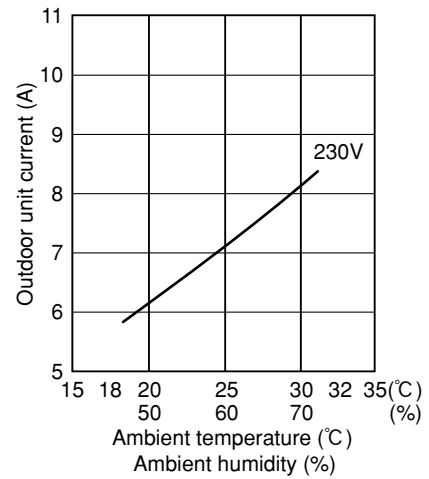
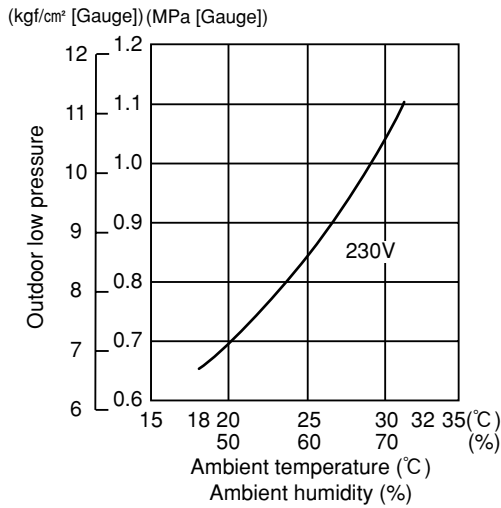

MUCFH-GA60VB

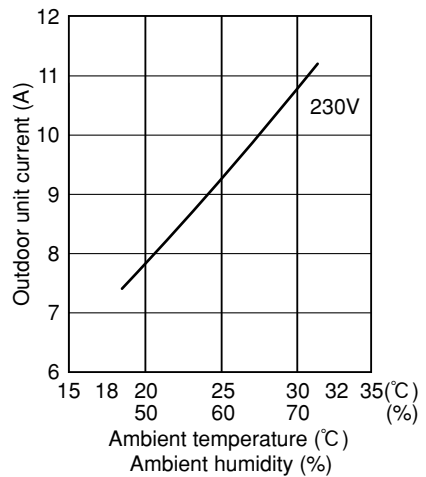
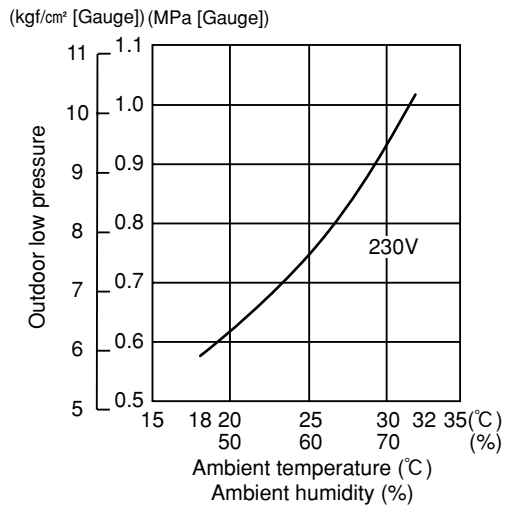

HEAT operation

Condition Indoor : Dry bulb temperature 20.0°C
Wet bulb temperature 14.5°C

Outdoor : Dry bulb temperature 7,15,20°C
Wet bulb temperature 6,12,14.5°C

MUCFH-GA35VB

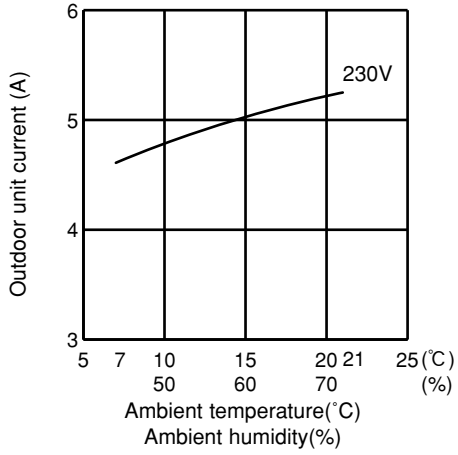

MUCFH-GA50VB

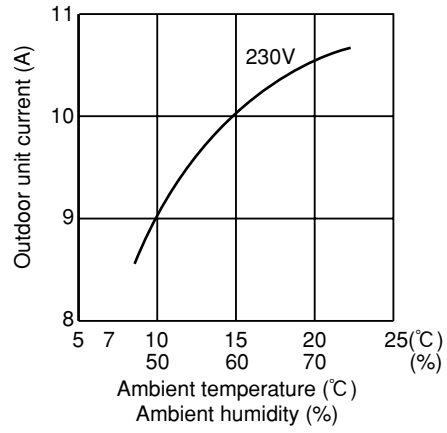

MUCFH-GA60VB

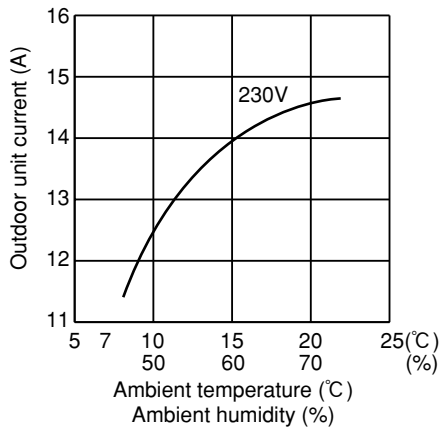

PERFORMANCE DATA

COOL operation (230V)

MCFH-GA35VB : MUCFH-GA35VB

CAPACITY :3.5(kW) SHF :0.70 INPUT :1160(W)

		OUTDOOR DB(°C)															
INDOOR DB(°C)	INDOOR WB(°C)	21				25				27				30			
		Q	SHC	SHF	INPUT	Q	SHC	SHF	INPUT	Q	SHC	SHF	INPUT	Q	SHC	SHF	INPUT
21	18	4.11	2.14	0.52	928	3.94	2.05	0.52	974	3.78	1.97	0.52	1021	3.64	1.89	0.52	1067
21	20	4.29	1.72	0.40	974	4.11	1.65	0.40	1032	3.99	1.60	0.40	1056	3.85	1.54	0.40	1102
22	18	4.11	2.30	0.56	928	3.94	2.21	0.56	974	3.78	2.12	0.56	1021	3.64	2.04	0.56	1067
22	20	4.29	1.89	0.44	974	4.11	1.81	0.44	1032	3.99	1.76	0.44	1056	3.85	1.69	0.44	1102
22	22	4.46	1.43	0.32	1009	4.31	1.38	0.32	1073	4.20	1.34	0.32	1102	4.03	1.29	0.32	1148
23	18	4.11	2.47	0.60	928	3.94	2.36	0.60	974	3.78	2.27	0.60	1021	3.64	2.18	0.60	1067
23	20	4.29	2.06	0.48	974	4.11	1.97	0.48	1032	3.99	1.92	0.48	1056	3.85	1.85	0.48	1102
23	22	4.46	1.61	0.36	1009	4.31	1.55	0.36	1073	4.20	1.51	0.36	1102	4.03	1.45	0.36	1148
24	18	4.11	2.63	0.64	928	3.94	2.52	0.64	974	3.78	2.42	0.64	1021	3.64	2.33	0.64	1067
24	20	4.29	2.23	0.52	974	4.11	2.14	0.52	1032	3.99	2.07	0.52	1056	3.85	2.00	0.52	1102
24	22	4.46	1.79	0.40	1009	4.31	1.72	0.40	1073	4.20	1.68	0.40	1102	4.03	1.61	0.40	1148
24	24	4.69	1.31	0.28	1056	4.52	1.26	0.28	1114	4.41	1.23	0.28	1148	4.27	1.20	0.28	1206
25	18	4.11	2.80	0.68	928	3.94	2.68	0.68	974	3.78	2.57	0.68	1021	3.64	2.48	0.68	1067
25	20	4.29	2.40	0.56	974	4.11	2.30	0.56	1032	3.99	2.23	0.56	1056	3.85	2.16	0.56	1102
25	22	4.46	1.96	0.44	1009	4.31	1.89	0.44	1073	4.20	1.85	0.44	1102	4.03	1.77	0.44	1148
25	24	4.69	1.50	0.32	1056	4.52	1.44	0.32	1114	4.41	1.41	0.32	1148	4.27	1.37	0.32	1206
26	18	4.11	2.96	0.72	928	3.94	2.84	0.72	974	3.78	2.72	0.72	1021	3.64	2.62	0.72	1067
26	20	4.29	2.57	0.60	974	4.11	2.47	0.60	1032	3.99	2.39	0.60	1056	3.85	2.31	0.60	1102
26	22	4.46	2.14	0.48	1009	4.31	2.07	0.48	1073	4.20	2.02	0.48	1102	4.03	1.93	0.48	1148
26	24	4.69	1.69	0.36	1056	4.52	1.63	0.36	1114	4.41	1.59	0.36	1148	4.27	1.54	0.36	1206
26	26	4.83	1.16	0.24	1114	4.69	1.13	0.24	1172	4.62	1.11	0.24	1206	4.48	1.08	0.24	1241
27	18	4.11	3.13	0.76	928	3.94	2.99	0.76	974	3.78	2.87	0.76	1021	3.64	2.77	0.76	1067
27	20	4.29	2.74	0.64	974	4.11	2.63	0.64	1032	3.99	2.55	0.64	1056	3.85	2.46	0.64	1102
27	22	4.46	2.32	0.52	1009	4.31	2.24	0.52	1073	4.20	2.18	0.52	1102	4.03	2.09	0.52	1148
27	24	4.69	1.88	0.40	1056	4.52	1.81	0.40	1114	4.41	1.76	0.40	1148	4.27	1.71	0.40	1206
27	26	4.83	1.35	0.28	1114	4.69	1.31	0.28	1172	4.62	1.29	0.28	1206	4.48	1.25	0.28	1241
28	18	4.11	3.29	0.80	928	3.94	3.15	0.80	974	3.78	3.02	0.80	1021	3.64	2.91	0.80	1067
28	20	4.29	2.92	0.68	974	4.11	2.80	0.68	1032	3.99	2.71	0.68	1056	3.85	2.62	0.68	1102
28	22	4.46	2.50	0.56	1009	4.31	2.41	0.56	1073	4.20	2.35	0.56	1102	4.03	2.25	0.56	1148
28	24	4.69	2.06	0.44	1056	4.52	1.99	0.44	1114	4.41	1.94	0.44	1148	4.27	1.88	0.44	1206
28	26	4.83	1.55	0.32	1114	4.69	1.50	0.32	1172	4.62	1.48	0.32	1206	4.48	1.43	0.32	1241
29	18	4.11	3.45	0.84	928	3.94	3.31	0.84	974	3.78	3.18	0.84	1021	3.64	3.06	0.84	1067
29	20	4.29	3.09	0.72	974	4.11	2.96	0.72	1032	3.99	2.87	0.72	1056	3.85	2.77	0.72	1102
29	22	4.46	2.68	0.60	1009	4.31	2.58	0.60	1073	4.20	2.52	0.60	1102	4.03	2.42	0.60	1148
29	24	4.69	2.25	0.48	1056	4.52	2.17	0.48	1114	4.41	2.12	0.48	1148	4.27	2.05	0.48	1206
29	26	4.83	1.74	0.36	1114	4.69	1.69	0.36	1172	4.62	1.66	0.36	1206	4.48	1.61	0.36	1241
30	18	4.11	3.62	0.88	928	3.94	3.47	0.88	974	3.78	3.33	0.88	1021	3.64	3.20	0.88	1067
30	20	4.29	3.26	0.76	974	4.11	3.13	0.76	1032	3.99	3.03	0.76	1056	3.85	2.93	0.76	1102
30	22	4.46	2.86	0.64	1009	4.31	2.76	0.64	1073	4.20	2.69	0.64	1102	4.03	2.58	0.64	1148
30	24	4.69	2.44	0.52	1056	4.52	2.35	0.52	1114	4.41	2.29	0.52	1148	4.27	2.22	0.52	1206
30	26	4.83	1.93	0.40	1114	4.69	1.88	0.40	1172	4.62	1.85	0.40	1206	4.48	1.79	0.40	1241
31	18	4.11	3.78	0.92	928	3.94	3.62	0.92	974	3.78	3.48	0.92	1021	3.64	3.35	0.92	1067
31	20	4.29	3.43	0.80	974	4.11	3.29	0.80	1032	3.99	3.19	0.80	1056	3.85	3.08	0.80	1102
31	22	4.46	3.03	0.68	1009	4.31	2.93	0.68	1073	4.20	2.86	0.68	1102	4.03	2.74	0.68	1148
31	24	4.69	2.63	0.56	1056	4.52	2.53	0.56	1114	4.41	2.47	0.56	1148	4.27	2.39	0.56	1206
31	26	4.83	2.13	0.44	1114	4.69	2.06	0.44	1172	4.62	2.03	0.44	1206	4.48	1.97	0.44	1241
32	18	4.11	3.95	0.96	928	3.94	3.78	0.96	974	3.78	3.63	0.96	1021	3.64	3.49	0.96	1067
32	20	4.29	3.60	0.84	974	4.11	3.45	0.84	1032	3.99	3.35	0.84	1056	3.85	3.23	0.84	1102
32	22	4.46	3.21	0.72	1009	4.31	3.10	0.72	1073	4.20	3.02	0.72	1102	4.03	2.90	0.72	1148
32	24	4.69	2.81	0.60	1056	4.52	2.71	0.60	1114	4.41	2.65	0.60	1148	4.27	2.56	0.60	1206
32	26	4.83	2.32	0.48	1114	4.69	2.25	0.48	1172	4.62	2.22	0.48	1206	4.48	2.15	0.48	1241

NOTE Q :Total capacity (kW) SHF :Sensible heat factor DB :Dry-bulb temperature
 SHC :Sensible heat capacity (kW) INPUT :Total power input (W) WB :Wet-bulb temperature

PERFORMANCE DATA

COOL operation (230V)

MCFH-GA35VB : MUCFH-GA35VB

CAPACITY :3.5(kW) SHF :0.70 INPUT :1160(W)

		OUTDOOR DB(°C)											
INDOOR DB(°C)	INDOOR WB(°C)	35				40				43			
		Q	SHC	SHF	INPUT	Q	SHC	SHF	INPUT	Q	SHC	SHF	INPUT
21	18	3.43	1.78	0.52	1137	3.15	1.64	0.52	1206	3.03	1.57	0.52	1230
21	20	3.61	1.44	0.40	1183	3.36	1.34	0.40	1241	3.24	1.30	0.40	1276
22	18	3.43	1.92	0.56	1137	3.15	1.76	0.56	1206	3.03	1.70	0.56	1230
22	20	3.61	1.59	0.44	1183	3.36	1.48	0.44	1241	3.24	1.42	0.44	1276
22	22	3.82	1.22	0.32	1230	3.57	1.14	0.32	1299	3.45	1.10	0.32	1322
23	18	3.43	2.06	0.60	1137	3.15	1.89	0.60	1206	3.03	1.82	0.60	1230
23	20	3.61	1.73	0.48	1183	3.36	1.61	0.48	1241	3.24	1.55	0.48	1276
23	22	3.82	1.37	0.36	1230	3.57	1.29	0.36	1299	3.45	1.24	0.36	1322
24	18	3.43	2.20	0.64	1137	3.15	2.02	0.64	1206	3.03	1.94	0.64	1230
24	20	3.61	1.87	0.52	1183	3.36	1.75	0.52	1241	3.24	1.68	0.52	1276
24	22	3.82	1.53	0.40	1230	3.57	1.43	0.40	1299	3.45	1.38	0.40	1322
24	24	4.03	1.13	0.28	1276	3.78	1.06	0.28	1334	3.68	1.03	0.28	1363
25	18	3.43	2.33	0.68	1137	3.15	2.14	0.68	1206	3.03	2.06	0.68	1230
25	20	3.61	2.02	0.56	1183	3.36	1.88	0.56	1241	3.24	1.81	0.56	1276
25	22	3.82	1.68	0.44	1230	3.57	1.57	0.44	1299	3.45	1.52	0.44	1322
25	24	4.03	1.29	0.32	1276	3.78	1.21	0.32	1334	3.68	1.18	0.32	1363
26	18	3.43	2.47	0.72	1137	3.15	2.27	0.72	1206	3.03	2.18	0.72	1230
26	20	3.61	2.16	0.60	1183	3.36	2.02	0.60	1241	3.24	1.94	0.60	1276
26	22	3.82	1.83	0.48	1230	3.57	1.71	0.48	1299	3.45	1.65	0.48	1322
26	24	4.03	1.45	0.36	1276	3.78	1.36	0.36	1334	3.68	1.32	0.36	1363
26	26	4.24	1.02	0.24	1322	3.99	0.96	0.24	1380	3.87	0.93	0.24	1409
27	18	3.43	2.61	0.76	1137	3.15	2.39	0.76	1206	3.03	2.30	0.76	1230
27	20	3.61	2.31	0.64	1183	3.36	2.15	0.64	1241	3.24	2.07	0.64	1276
27	22	3.82	1.98	0.52	1230	3.57	1.86	0.52	1299	3.45	1.79	0.52	1322
27	24	4.03	1.61	0.40	1276	3.78	1.51	0.40	1334	3.68	1.47	0.40	1363
27	26	4.24	1.19	0.28	1322	3.99	1.12	0.28	1380	3.87	1.08	0.28	1409
28	18	3.43	2.74	0.80	1137	3.15	2.52	0.80	1206	3.03	2.42	0.80	1230
28	20	3.61	2.45	0.68	1183	3.36	2.28	0.68	1241	3.24	2.20	0.68	1276
28	22	3.82	2.14	0.56	1230	3.57	2.00	0.56	1299	3.45	1.93	0.56	1322
28	24	4.03	1.77	0.44	1276	3.78	1.66	0.44	1334	3.68	1.62	0.44	1363
28	26	4.24	1.36	0.32	1322	3.99	1.28	0.32	1380	3.87	1.24	0.32	1409
29	18	3.43	2.88	0.84	1137	3.15	2.65	0.84	1206	3.03	2.54	0.84	1230
29	20	3.61	2.60	0.72	1183	3.36	2.42	0.72	1241	3.24	2.33	0.72	1276
29	22	3.82	2.29	0.60	1230	3.57	2.14	0.60	1299	3.45	2.07	0.60	1322
29	24	4.03	1.93	0.48	1276	3.78	1.81	0.48	1334	3.68	1.76	0.48	1363
29	26	4.24	1.52	0.36	1322	3.99	1.44	0.36	1380	3.87	1.39	0.36	1409
30	18	3.43	3.02	0.88	1137	3.15	2.77	0.88	1206	3.03	2.66	0.88	1230
30	20	3.61	2.74	0.76	1183	3.36	2.55	0.76	1241	3.24	2.46	0.76	1276
30	22	3.82	2.44	0.64	1230	3.57	2.28	0.64	1299	3.45	2.21	0.64	1322
30	24	4.03	2.09	0.52	1276	3.78	1.97	0.52	1334	3.68	1.91	0.52	1363
30	26	4.24	1.69	0.40	1322	3.99	1.60	0.40	1380	3.87	1.55	0.40	1409
31	18	3.43	3.16	0.92	1137	3.15	2.90	0.92	1206	3.03	2.79	0.92	1230
31	20	3.61	2.88	0.80	1183	3.36	2.69	0.80	1241	3.24	2.59	0.80	1276
31	22	3.82	2.59	0.68	1230	3.57	2.43	0.68	1299	3.45	2.34	0.68	1322
31	24	4.03	2.25	0.56	1276	3.78	2.12	0.56	1334	3.68	2.06	0.56	1363
31	26	4.24	1.86	0.44	1322	3.99	1.76	0.44	1380	3.87	1.70	0.44	1409
32	18	3.43	3.29	0.96	1137	3.15	3.02	0.96	1206	3.03	2.91	0.96	1230
32	20	3.61	3.03	0.84	1183	3.36	2.82	0.84	1241	3.24	2.72	0.84	1276
32	22	3.82	2.75	0.72	1230	3.57	2.57	0.72	1299	3.45	2.48	0.72	1322
32	24	4.03	2.42	0.60	1276	3.78	2.27	0.60	1334	3.68	2.21	0.60	1363
32	26	4.24	2.03	0.48	1322	3.99	1.92	0.48	1380	3.87	1.86	0.48	1409

NOTE Q :Total capacity (kW) SHF :Sensible heat factor DB :Dry-bulb temperature
 SHC :Sensible heat capacity (kW) INPUT :Total power input (W) WB :Wet-bulb temperature

PERFORMANCE DATA COOL operation(230V)
MCFH-GA50VB : MUCFH-GA50VB

CAPACITY :4.8(kW) SHF :0.65 INPUT :1810(W)

		OUTDOOR DB(°C)															
INDOOR DB(°C)	INDOOR WB(°C)	21				25				27				30			
		Q	SHC	SHF	INPUT	Q	SHC	SHF	INPUT	Q	SHC	SHF	INPUT	Q	SHC	SHF	INPUT
21	18	5.64	2.65	0.47	1448	5.40	2.54	0.47	1520	5.18	2.44	0.47	1593	4.99	2.35	0.47	1665
21	20	5.88	2.06	0.35	1520	5.64	1.97	0.35	1611	5.47	1.92	0.35	1647	5.28	1.85	0.35	1720
22	18	5.64	2.88	0.51	1448	5.40	2.75	0.51	1520	5.18	2.64	0.51	1593	4.99	2.55	0.51	1665
22	20	5.88	2.29	0.39	1520	5.64	2.20	0.39	1611	5.47	2.13	0.39	1647	5.28	2.06	0.39	1720
22	22	6.12	1.65	0.27	1575	5.90	1.59	0.27	1674	5.76	1.56	0.27	1720	5.52	1.49	0.27	1792
23	18	5.64	3.10	0.55	1448	5.40	2.97	0.55	1520	5.18	2.85	0.55	1593	4.99	2.75	0.55	1665
23	20	5.88	2.53	0.43	1520	5.64	2.43	0.43	1611	5.47	2.35	0.43	1647	5.28	2.27	0.43	1720
23	22	6.12	1.90	0.31	1575	5.90	1.83	0.31	1674	5.76	1.79	0.31	1720	5.52	1.71	0.31	1792
24	18	5.64	3.33	0.59	1448	5.40	3.19	0.59	1520	5.18	3.06	0.59	1593	4.99	2.95	0.59	1665
24	20	5.88	2.76	0.47	1520	5.64	2.65	0.47	1611	5.47	2.57	0.47	1647	5.28	2.48	0.47	1720
24	22	6.12	2.14	0.35	1575	5.90	2.07	0.35	1674	5.76	2.02	0.35	1720	5.52	1.93	0.35	1792
24	24	6.43	1.48	0.23	1647	6.19	1.42	0.23	1738	6.05	1.39	0.23	1792	5.86	1.35	0.23	1882
25	18	5.64	3.55	0.63	1448	5.40	3.40	0.63	1520	5.18	3.27	0.63	1593	4.99	3.14	0.63	1665
25	20	5.88	3.00	0.51	1520	5.64	2.88	0.51	1611	5.47	2.79	0.51	1647	5.28	2.69	0.51	1720
25	22	6.12	2.39	0.39	1575	5.90	2.30	0.39	1674	5.76	2.25	0.39	1720	5.52	2.15	0.39	1792
25	24	6.43	1.74	0.27	1647	6.19	1.67	0.27	1738	6.05	1.63	0.27	1792	5.86	1.58	0.27	1882
26	18	5.64	3.78	0.67	1448	5.40	3.62	0.67	1520	5.18	3.47	0.67	1593	4.99	3.34	0.67	1665
26	20	5.88	3.23	0.55	1520	5.64	3.10	0.55	1611	5.47	3.01	0.55	1647	5.28	2.90	0.55	1720
26	22	6.12	2.63	0.43	1575	5.90	2.54	0.43	1674	5.76	2.48	0.43	1720	5.52	2.37	0.43	1792
26	24	6.43	1.99	0.31	1647	6.19	1.92	0.31	1738	6.05	1.87	0.31	1792	5.86	1.82	0.31	1882
26	26	6.62	1.26	0.19	1738	6.43	1.22	0.19	1828	6.34	1.20	0.19	1882	6.14	1.17	0.19	1937
27	18	5.64	4.00	0.71	1448	5.40	3.83	0.71	1520	5.18	3.68	0.71	1593	4.99	3.54	0.71	1665
27	20	5.88	3.47	0.59	1520	5.64	3.33	0.59	1611	5.47	3.23	0.59	1647	5.28	3.12	0.59	1720
27	22	6.12	2.88	0.47	1575	5.90	2.77	0.47	1674	5.76	2.71	0.47	1720	5.52	2.59	0.47	1792
27	24	6.43	2.25	0.35	1647	6.19	2.17	0.35	1738	6.05	2.12	0.35	1792	5.86	2.05	0.35	1882
27	26	6.62	1.52	0.23	1738	6.43	1.48	0.23	1828	6.34	1.46	0.23	1882	6.14	1.41	0.23	1937
28	18	5.64	4.23	0.75	1448	5.40	4.05	0.75	1520	5.18	3.89	0.75	1593	4.99	3.74	0.75	1665
28	20	5.88	3.70	0.63	1520	5.64	3.55	0.63	1611	5.47	3.45	0.63	1647	5.28	3.33	0.63	1720
28	22	6.12	3.12	0.51	1575	5.90	3.01	0.51	1674	5.76	2.94	0.51	1720	5.52	2.82	0.51	1792
28	24	6.43	2.51	0.39	1647	6.19	2.41	0.39	1738	6.05	2.36	0.39	1792	5.86	2.28	0.39	1882
28	26	6.62	1.79	0.27	1738	6.43	1.74	0.27	1828	6.34	1.71	0.27	1882	6.14	1.66	0.27	1937
29	18	5.64	4.46	0.79	1448	5.40	4.27	0.79	1520	5.18	4.10	0.79	1593	4.99	3.94	0.79	1665
29	20	5.88	3.94	0.67	1520	5.64	3.78	0.67	1611	5.47	3.67	0.67	1647	5.28	3.54	0.67	1720
29	22	6.12	3.37	0.55	1575	5.90	3.25	0.55	1674	5.76	3.17	0.55	1720	5.52	3.04	0.55	1792
29	24	6.43	2.77	0.43	1647	6.19	2.66	0.43	1738	6.05	2.60	0.43	1792	5.86	2.52	0.43	1882
29	26	6.62	2.05	0.31	1738	6.43	1.99	0.31	1828	6.34	1.96	0.31	1882	6.14	1.90	0.31	1937
30	18	5.64	4.68	0.83	1448	5.40	4.48	0.83	1520	5.18	4.30	0.83	1593	4.99	4.14	0.83	1665
30	20	5.88	4.17	0.71	1520	5.64	4.00	0.71	1611	5.47	3.89	0.71	1647	5.28	3.75	0.71	1720
30	22	6.12	3.61	0.59	1575	5.90	3.48	0.59	1674	5.76	3.40	0.59	1720	5.52	3.26	0.59	1792
30	24	6.43	3.02	0.47	1647	6.19	2.91	0.47	1738	6.05	2.84	0.47	1792	5.86	2.75	0.47	1882
30	26	6.62	2.32	0.35	1738	6.43	2.25	0.35	1828	6.34	2.22	0.35	1882	6.14	2.15	0.35	1937
31	18	5.64	4.91	0.87	1448	5.40	4.70	0.87	1520	5.18	4.51	0.87	1593	4.99	4.34	0.87	1665
31	20	5.88	4.41	0.75	1520	5.64	4.23	0.75	1611	5.47	4.10	0.75	1647	5.28	3.96	0.75	1720
31	22	6.12	3.86	0.63	1575	5.90	3.72	0.63	1674	5.76	3.63	0.63	1720	5.52	3.48	0.63	1792
31	24	6.43	3.28	0.51	1647	6.19	3.16	0.51	1738	6.05	3.08	0.51	1792	5.86	2.99	0.51	1882
31	26	6.62	2.58	0.39	1738	6.43	2.51	0.39	1828	6.34	2.47	0.39	1882	6.14	2.40	0.39	1937
32	18	5.64	5.13	0.91	1448	5.40	4.91	0.91	1520	5.18	4.72	0.91	1593	4.99	4.54	0.91	1665
32	20	5.88	4.65	0.79	1520	5.64	4.46	0.79	1611	5.47	4.32	0.79	1647	5.28	4.17	0.79	1720
32	22	6.12	4.10	0.67	1575	5.90	3.96	0.67	1674	5.76	3.86	0.67	1720	5.52	3.70	0.67	1792
32	24	6.43	3.54	0.55	1647	6.19	3.41	0.55	1738	6.05	3.33	0.55	1792	5.86	3.22	0.55	1882
32	26	6.62	2.85	0.43	1738	6.43	2.77	0.43	1828	6.34	2.72	0.43	1882	6.14	2.64	0.43	1937

NOTE Q : Total capacity (kW) SHF : Sensible heat factor DB : Dry-bulb temperature
SHC : Sensible heat capacity (kW) INPUT : Total power input (W) WB : Wet-bulb temperature

PERFORMANCE DATA COOL operation(230V)

MCFH-GA50VB : MUCFH-GA50VB

CAPACITY :4.8(kW) SHF :0.65 INPUT :1810(W)

		OUTDOOR DB(°C)											
INDOOR DB(°C)	INDOOR WB(°C)	35				40				43			
		Q	SHC	SHF	INPUT	Q	SHC	SHF	INPUT	Q	SHC	SHF	INPUT
21	18	4.70	2.21	0.47	1774	4.32	2.03	0.47	1882	4.15	1.95	0.47	1919
21	20	4.94	1.73	0.35	1846	4.61	1.61	0.35	1937	4.44	1.55	0.35	1991
22	18	4.70	2.40	0.51	1774	4.32	2.20	0.51	1882	4.15	2.12	0.51	1919
22	20	4.94	1.93	0.39	1846	4.61	1.80	0.39	1937	4.44	1.73	0.39	1991
22	22	5.23	1.41	0.27	1919	4.90	1.32	0.27	2027	4.73	1.28	0.27	2063
23	18	4.70	2.59	0.55	1774	4.32	2.38	0.55	1882	4.15	2.28	0.55	1919
23	20	4.94	2.13	0.43	1846	4.61	1.98	0.43	1937	4.44	1.91	0.43	1991
23	22	5.23	1.62	0.31	1919	4.90	1.52	0.31	2027	4.73	1.47	0.31	2063
24	18	4.70	2.78	0.59	1774	4.32	2.55	0.59	1882	4.15	2.45	0.59	1919
24	20	4.94	2.32	0.47	1846	4.61	2.17	0.47	1937	4.44	2.09	0.47	1991
24	22	5.23	1.83	0.35	1919	4.90	1.71	0.35	2027	4.73	1.65	0.35	2063
24	24	5.52	1.27	0.23	1991	5.18	1.19	0.23	2082	5.04	1.16	0.23	2127
25	18	4.70	2.96	0.63	1774	4.32	2.72	0.63	1882	4.15	2.62	0.63	1919
25	20	4.94	2.52	0.51	1846	4.61	2.35	0.51	1937	4.44	2.26	0.51	1991
25	22	5.23	2.04	0.39	1919	4.90	1.91	0.39	2027	4.73	1.84	0.39	2063
25	24	5.52	1.49	0.27	1991	5.18	1.40	0.27	2082	5.04	1.36	0.27	2127
26	18	4.70	3.15	0.67	1774	4.32	2.89	0.67	1882	4.15	2.78	0.67	1919
26	20	4.94	2.72	0.55	1846	4.61	2.53	0.55	1937	4.44	2.44	0.55	1991
26	22	5.23	2.25	0.43	1919	4.90	2.11	0.43	2027	4.73	2.03	0.43	2063
26	24	5.52	1.71	0.31	1991	5.18	1.61	0.31	2082	5.04	1.56	0.31	2127
26	26	5.81	1.10	0.19	2063	5.47	1.04	0.19	2154	5.30	1.01	0.19	2199
27	18	4.70	3.34	0.71	1774	4.32	3.07	0.71	1882	4.15	2.95	0.71	1919
27	20	4.94	2.92	0.59	1846	4.61	2.72	0.59	1937	4.44	2.62	0.59	1991
27	22	5.23	2.46	0.47	1919	4.90	2.30	0.47	2027	4.73	2.22	0.47	2063
27	24	5.52	1.93	0.35	1991	5.18	1.81	0.35	2082	5.04	1.76	0.35	2127
27	26	5.81	1.34	0.23	2063	5.47	1.26	0.23	2154	5.30	1.22	0.23	2199
28	18	4.70	3.53	0.75	1774	4.32	3.24	0.75	1882	4.15	3.11	0.75	1919
28	20	4.94	3.11	0.63	1846	4.61	2.90	0.63	1937	4.44	2.80	0.63	1991
28	22	5.23	2.67	0.51	1919	4.90	2.50	0.51	2027	4.73	2.41	0.51	2063
28	24	5.52	2.15	0.39	1991	5.18	2.02	0.39	2082	5.04	1.97	0.39	2127
28	26	5.81	1.57	0.27	2063	5.47	1.48	0.27	2154	5.30	1.43	0.27	2199
29	18	4.70	3.72	0.79	1774	4.32	3.41	0.79	1882	4.15	3.28	0.79	1919
29	20	4.94	3.31	0.67	1846	4.61	3.09	0.67	1937	4.44	2.97	0.67	1991
29	22	5.23	2.88	0.55	1919	4.90	2.69	0.55	2027	4.73	2.60	0.55	2063
29	24	5.52	2.37	0.43	1991	5.18	2.23	0.43	2082	5.04	2.17	0.43	2127
29	26	5.81	1.80	0.31	2063	5.47	1.70	0.31	2154	5.30	1.64	0.31	2199
30	18	4.70	3.90	0.83	1774	4.32	3.59	0.83	1882	4.15	3.45	0.83	1919
30	20	4.94	3.51	0.71	1846	4.61	3.27	0.71	1937	4.44	3.15	0.71	1991
30	22	5.23	3.09	0.59	1919	4.90	2.89	0.59	2027	4.73	2.79	0.59	2063
30	24	5.52	2.59	0.47	1991	5.18	2.44	0.47	2082	5.04	2.37	0.47	2127
30	26	5.81	2.03	0.35	2063	5.47	1.92	0.35	2154	5.30	1.86	0.35	2199
31	18	4.70	4.09	0.87	1774	4.32	3.76	0.87	1882	4.15	3.61	0.87	1919
31	20	4.94	3.71	0.75	1846	4.61	3.46	0.75	1937	4.44	3.33	0.75	1991
31	22	5.23	3.30	0.63	1919	4.90	3.08	0.63	2027	4.73	2.98	0.63	2063
31	24	5.52	2.82	0.51	1991	5.18	2.64	0.51	2082	5.04	2.57	0.51	2127
31	26	5.81	2.27	0.39	2063	5.47	2.13	0.39	2154	5.30	2.07	0.39	2199
32	18	4.70	4.28	0.91	1774	4.32	3.93	0.91	1882	4.15	3.78	0.91	1919
32	20	4.94	3.91	0.79	1846	4.61	3.64	0.79	1937	4.44	3.51	0.79	1991
32	22	5.23	3.51	0.67	1919	4.90	3.28	0.67	2027	4.73	3.17	0.67	2063
32	24	5.52	3.04	0.55	1991	5.18	2.85	0.55	2082	5.04	2.77	0.55	2127
32	26	5.81	2.50	0.43	2063	5.47	2.35	0.43	2154	5.30	2.28	0.43	2199

NOTE Q : Total capacity (kW) SHF : Sensible heat factor DB : Dry-bulb temperature
 SHC : Sensible heat capacity (kW) INPUT : Total power input (W) WB : Wet-bulb temperature

PERFORMANCE DATA COOL operation(230V)
MCFH-GA60VB : MUCFH-GA60VB

CAPACITY :6.0(kW) SHF :0.64 INPUT :2450(W)

		OUTDOOR DB(°C)															
INDOOR DB(°C)	INDOOR WB(°C)	21				25				27				30			
		Q	SHC	SHF	INPUT	Q	SHC	SHF	INPUT	Q	SHC	SHF	INPUT	Q	SHC	SHF	INPUT
21	18	7.05	3.24	0.46	1960	6.75	3.11	0.46	2058	6.48	2.98	0.46	2156	6.24	2.87	0.46	2254
21	20	7.35	2.50	0.34	2058	7.05	2.40	0.34	2181	6.84	2.33	0.34	2230	6.60	2.24	0.34	2328
22	18	7.05	3.53	0.50	1960	6.75	3.38	0.50	2058	6.48	3.24	0.50	2156	6.24	3.12	0.50	2254
22	20	7.35	2.79	0.38	2058	7.05	2.68	0.38	2181	6.84	2.60	0.38	2230	6.60	2.51	0.38	2328
22	22	7.65	1.99	0.26	2132	7.38	1.92	0.26	2266	7.20	1.87	0.26	2328	6.90	1.79	0.26	2426
23	18	7.05	3.81	0.54	1960	6.75	3.65	0.54	2058	6.48	3.50	0.54	2156	6.24	3.37	0.54	2254
23	20	7.35	3.09	0.42	2058	7.05	2.96	0.42	2181	6.84	2.87	0.42	2230	6.60	2.77	0.42	2328
23	22	7.65	2.30	0.30	2132	7.38	2.21	0.30	2266	7.20	2.16	0.30	2328	6.90	2.07	0.30	2426
24	18	7.05	4.09	0.58	1960	6.75	3.92	0.58	2058	6.48	3.76	0.58	2156	6.24	3.62	0.58	2254
24	20	7.35	3.38	0.46	2058	7.05	3.24	0.46	2181	6.84	3.15	0.46	2230	6.60	3.04	0.46	2328
24	22	7.65	2.60	0.34	2132	7.38	2.51	0.34	2266	7.20	2.45	0.34	2328	6.90	2.35	0.34	2426
24	24	8.04	1.77	0.22	2230	7.74	1.70	0.22	2352	7.56	1.66	0.22	2426	7.32	1.61	0.22	2548
25	18	7.05	4.37	0.62	1960	6.75	4.19	0.62	2058	6.48	4.02	0.62	2156	6.24	3.87	0.62	2254
25	20	7.35	3.68	0.50	2058	7.05	3.53	0.50	2181	6.84	3.42	0.50	2230	6.60	3.30	0.50	2328
25	22	7.65	2.91	0.38	2132	7.38	2.80	0.38	2266	7.20	2.74	0.38	2328	6.90	2.62	0.38	2426
25	24	8.04	2.09	0.26	2230	7.74	2.01	0.26	2352	7.56	1.97	0.26	2426	7.32	1.90	0.26	2548
26	18	7.05	4.65	0.66	1960	6.75	4.46	0.66	2058	6.48	4.28	0.66	2156	6.24	4.12	0.66	2254
26	20	7.35	3.97	0.54	2058	7.05	3.81	0.54	2181	6.84	3.69	0.54	2230	6.60	3.56	0.54	2328
26	22	7.65	3.21	0.42	2132	7.38	3.10	0.42	2266	7.20	3.02	0.42	2328	6.90	2.90	0.42	2426
26	24	8.04	2.41	0.30	2230	7.74	2.32	0.30	2352	7.56	2.27	0.30	2426	7.32	2.20	0.30	2548
26	26	8.28	1.49	0.18	2352	8.04	1.45	0.18	2475	7.92	1.43	0.18	2548	7.68	1.38	0.18	2622
27	18	7.05	4.94	0.70	1960	6.75	4.73	0.70	2058	6.48	4.54	0.70	2156	6.24	4.37	0.70	2254
27	20	7.35	4.26	0.58	2058	7.05	4.09	0.58	2181	6.84	3.97	0.58	2230	6.60	3.83	0.58	2328
27	22	7.65	3.52	0.46	2132	7.38	3.39	0.46	2266	7.20	3.31	0.46	2328	6.90	3.17	0.46	2426
27	24	8.04	2.73	0.34	2230	7.74	2.63	0.34	2352	7.56	2.57	0.34	2426	7.32	2.49	0.34	2548
27	26	8.28	1.82	0.22	2352	8.04	1.77	0.22	2475	7.92	1.74	0.22	2548	7.68	1.69	0.22	2622
28	18	7.05	5.22	0.74	1960	6.75	5.00	0.74	2058	6.48	4.80	0.74	2156	6.24	4.62	0.74	2254
28	20	7.35	4.56	0.62	2058	7.05	4.37	0.62	2181	6.84	4.24	0.62	2230	6.60	4.09	0.62	2328
28	22	7.65	3.83	0.50	2132	7.38	3.69	0.50	2266	7.20	3.60	0.50	2328	6.90	3.45	0.50	2426
28	24	8.04	3.06	0.38	2230	7.74	2.94	0.38	2352	7.56	2.87	0.38	2426	7.32	2.78	0.38	2548
28	26	8.28	2.15	0.26	2352	8.04	2.09	0.26	2475	7.92	2.06	0.26	2548	7.68	2.00	0.26	2622
29	18	7.05	5.50	0.78	1960	6.75	5.27	0.78	2058	6.48	5.05	0.78	2156	6.24	4.87	0.78	2254
29	20	7.35	4.85	0.66	2058	7.05	4.65	0.66	2181	6.84	4.51	0.66	2230	6.60	4.36	0.66	2328
29	22	7.65	4.13	0.54	2132	7.38	3.99	0.54	2266	7.20	3.89	0.54	2328	6.90	3.73	0.54	2426
29	24	8.04	3.38	0.42	2230	7.74	3.25	0.42	2352	7.56	3.18	0.42	2426	7.32	3.07	0.42	2548
29	26	8.28	2.48	0.30	2352	8.04	2.41	0.30	2475	7.92	2.38	0.30	2548	7.68	2.30	0.30	2622
30	18	7.05	5.78	0.82	1960	6.75	5.54	0.82	2058	6.48	5.31	0.82	2156	6.24	5.12	0.82	2254
30	20	7.35	5.15	0.70	2058	7.05	4.94	0.70	2181	6.84	4.79	0.70	2230	6.60	4.62	0.70	2328
30	22	7.65	4.44	0.58	2132	7.38	4.28	0.58	2266	7.20	4.18	0.58	2328	6.90	4.00	0.58	2426
30	24	8.04	3.70	0.46	2230	7.74	3.56	0.46	2352	7.56	3.48	0.46	2426	7.32	3.37	0.46	2548
30	26	8.28	2.82	0.34	2352	8.04	2.73	0.34	2475	7.92	2.69	0.34	2548	7.68	2.61	0.34	2622
31	18	7.05	6.06	0.86	1960	6.75	5.81	0.86	2058	6.48	5.57	0.86	2156	6.24	5.37	0.86	2254
31	20	7.35	5.44	0.74	2058	7.05	5.22	0.74	2181	6.84	5.06	0.74	2230	6.60	4.88	0.74	2328
31	22	7.65	4.74	0.62	2132	7.38	4.58	0.62	2266	7.20	4.46	0.62	2328	6.90	4.28	0.62	2426
31	24	8.04	4.02	0.50	2230	7.74	3.87	0.50	2352	7.56	3.78	0.50	2426	7.32	3.66	0.50	2548
31	26	8.28	3.15	0.38	2352	8.04	3.06	0.38	2475	7.92	3.01	0.38	2548	7.68	2.92	0.38	2622
32	18	7.05	6.35	0.90	1960	6.75	6.08	0.90	2058	6.48	5.83	0.90	2156	6.24	5.62	0.90	2254
32	20	7.35	5.73	0.78	2058	7.05	5.50	0.78	2181	6.84	5.34	0.78	2230	6.60	5.15	0.78	2328
32	22	7.65	5.05	0.66	2132	7.38	4.87	0.66	2266	7.20	4.75	0.66	2328	6.90	4.55	0.66	2426
32	24	8.04	4.34	0.54	2230	7.74	4.18	0.54	2352	7.56	4.08	0.54	2426	7.32	3.95	0.54	2548
32	26	8.28	3.48	0.42	2352	8.04	3.38	0.42	2475	7.92	3.33	0.42	2548	7.68	3.23	0.42	2622

NOTE Q : Total capacity (kW) SHF : Sensible heat factor DB : Dry-bulb temperature
 SHC : Sensible heat capacity (kW) INPUT : Total power input (W) WB : Wet-bulb temperature

PERFORMANCE DATA COOL operation(230V)
MCFH-GA60VB : MUCFH-GA60VB

CAPACITY :6.0(kW) SHF :0.64 INPUT :2450(W)

		OUTDOOR DB(°C)											
INDOOR DB(°C)	INDOOR WB(°C)	35				40				43			
		Q	SHC	SHF	INPUT	Q	SHC	SHF	INPUT	Q	SHC	SHF	INPUT
21	18	5.88	2.70	0.46	2401	5.40	2.48	0.46	2548	5.19	2.39	0.46	2597
21	20	6.18	2.10	0.34	2499	5.76	1.96	0.34	2622	5.55	1.89	0.34	2695
22	18	5.88	2.94	0.50	2401	5.40	2.70	0.50	2548	5.19	2.60	0.50	2597
22	20	6.18	2.35	0.38	2499	5.76	2.19	0.38	2622	5.55	2.11	0.38	2695
22	22	6.54	1.70	0.26	2597	6.12	1.59	0.26	2744	5.91	1.54	0.26	2793
23	18	5.88	3.18	0.54	2401	5.40	2.92	0.54	2548	5.19	2.80	0.54	2597
23	20	6.18	2.60	0.42	2499	5.76	2.42	0.42	2622	5.55	2.33	0.42	2695
23	22	6.54	1.96	0.30	2597	6.12	1.84	0.30	2744	5.91	1.77	0.30	2793
24	18	5.88	3.41	0.58	2401	5.40	3.13	0.58	2548	5.19	3.01	0.58	2597
24	20	6.18	2.84	0.46	2499	5.76	2.65	0.46	2622	5.55	2.55	0.46	2695
24	22	6.54	2.22	0.34	2597	6.12	2.08	0.34	2744	5.91	2.01	0.34	2793
24	24	6.90	1.52	0.22	2695	6.48	1.43	0.22	2818	6.30	1.39	0.22	2879
25	18	5.88	3.65	0.62	2401	5.40	3.35	0.62	2548	5.19	3.22	0.62	2597
25	20	6.18	3.09	0.50	2499	5.76	2.88	0.50	2622	5.55	2.78	0.50	2695
25	22	6.54	2.49	0.38	2597	6.12	2.33	0.38	2744	5.91	2.25	0.38	2793
25	24	6.90	1.79	0.26	2695	6.48	1.68	0.26	2818	6.30	1.64	0.26	2879
26	18	5.88	3.88	0.66	2401	5.40	3.56	0.66	2548	5.19	3.43	0.66	2597
26	20	6.18	3.34	0.54	2499	5.76	3.11	0.54	2622	5.55	3.00	0.54	2695
26	22	6.54	2.75	0.42	2597	6.12	2.57	0.42	2744	5.91	2.48	0.42	2793
26	24	6.90	2.07	0.30	2695	6.48	1.94	0.30	2818	6.30	1.89	0.30	2879
26	26	7.26	1.31	0.18	2793	6.84	1.23	0.18	2916	6.63	1.19	0.18	2977
27	18	5.88	4.12	0.70	2401	5.40	3.78	0.70	2548	5.19	3.63	0.70	2597
27	20	6.18	3.58	0.58	2499	5.76	3.34	0.58	2622	5.55	3.22	0.58	2695
27	22	6.54	3.01	0.46	2597	6.12	2.82	0.46	2744	5.91	2.72	0.46	2793
27	24	6.90	2.35	0.34	2695	6.48	2.20	0.34	2818	6.30	2.14	0.34	2879
27	26	7.26	1.60	0.22	2793	6.84	1.50	0.22	2916	6.63	1.46	0.22	2977
28	18	5.88	4.35	0.74	2401	5.40	4.00	0.74	2548	5.19	3.84	0.74	2597
28	20	6.18	3.83	0.62	2499	5.76	3.57	0.62	2622	5.55	3.44	0.62	2695
28	22	6.54	3.27	0.50	2597	6.12	3.06	0.50	2744	5.91	2.96	0.50	2793
28	24	6.90	2.62	0.38	2695	6.48	2.46	0.38	2818	6.30	2.39	0.38	2879
28	26	7.26	1.89	0.26	2793	6.84	1.78	0.26	2916	6.63	1.72	0.26	2977
29	18	5.88	4.59	0.78	2401	5.40	4.21	0.78	2548	5.19	4.05	0.78	2597
29	20	6.18	4.08	0.66	2499	5.76	3.80	0.66	2622	5.55	3.66	0.66	2695
29	22	6.54	3.53	0.54	2597	6.12	3.30	0.54	2744	5.91	3.19	0.54	2793
29	24	6.90	2.90	0.42	2695	6.48	2.72	0.42	2818	6.30	2.65	0.42	2879
29	26	7.26	2.18	0.30	2793	6.84	2.05	0.30	2916	6.63	1.99	0.30	2977
30	18	5.88	4.82	0.82	2401	5.40	4.43	0.82	2548	5.19	4.26	0.82	2597
30	20	6.18	4.33	0.70	2499	5.76	4.03	0.70	2622	5.55	3.89	0.70	2695
30	22	6.54	3.79	0.58	2597	6.12	3.55	0.58	2744	5.91	3.43	0.58	2793
30	24	6.90	3.17	0.46	2695	6.48	2.98	0.46	2818	6.30	2.90	0.46	2879
30	26	7.26	2.47	0.34	2793	6.84	2.33	0.34	2916	6.63	2.25	0.34	2977
31	18	5.88	5.06	0.86	2401	5.40	4.64	0.86	2548	5.19	4.46	0.86	2597
31	20	6.18	4.57	0.74	2499	5.76	4.26	0.74	2622	5.55	4.11	0.74	2695
31	22	6.54	4.05	0.62	2597	6.12	3.79	0.62	2744	5.91	3.66	0.62	2793
31	24	6.90	3.45	0.50	2695	6.48	3.24	0.50	2818	6.30	3.15	0.50	2879
31	26	7.26	2.76	0.38	2793	6.84	2.60	0.38	2916	6.63	2.52	0.38	2977
32	18	5.88	5.29	0.90	2401	5.40	4.86	0.90	2548	5.19	4.67	0.90	2597
32	20	6.18	4.82	0.78	2499	5.76	4.49	0.78	2622	5.55	4.33	0.78	2695
32	22	6.54	4.32	0.66	2597	6.12	4.04	0.66	2744	5.91	3.90	0.66	2793
32	24	6.90	3.73	0.54	2695	6.48	3.50	0.54	2818	6.30	3.40	0.54	2879
32	26	7.26	3.05	0.42	2793	6.84	2.87	0.42	2916	6.63	2.78	0.42	2977

NOTE Q : Total capacity (kW) SHF : Sensible heat factor DB : Dry-bulb temperature
 SHC : Sensible heat capacity (kW) INPUT : Total power input (W) WB : Wet-bulb temperature

PERFORMANCE DATA

HEAT operation(230V)

MCFH-GA35VB : MUCFH-GA35VB

CAPACITY : 3.7(kW) INPUT : 1020(W)

INDOOR DB(°C)	OUTDOOR WB(°C)													
	-10		-5		0		5		10		15		20	
	Q	INPUT	Q	INPUT	Q	INPUT	Q	INPUT	Q	INPUT	Q	INPUT	Q	INPUT
15	2.33	663	2.81	796	3.29	898	3.77	969	4.26	1030	4.70	1061	5.18	1081
21	2.22	714	2.66	847	3.15	938	3.59	1010	4.07	1061	4.51	1091	4.98	1132
26	2.00	765	2.48	898	2.92	989	3.40	1061	3.89	1112	4.33	1142	4.81	1173

HEAT operation(230V)

MCFH-GA50VB : MUCFH-GA50VB

CAPACITY :5.0(kW) INPUT :1890(W)

INDOOR DB(°C)	OUTDOOR WB(°C)													
	-10		-5		0		5		10		15		20	
	Q	INPUT	Q	INPUT	Q	INPUT	Q	INPUT	Q	INPUT	Q	INPUT	Q	INPUT
15	3.15	1229	3.80	1474	4.45	1663	5.10	1796	5.75	1909	6.35	1966	7.00	2003
21	3.00	1323	3.60	1569	4.25	1739	4.85	1871	5.50	1966	6.10	2022	6.73	2098
26	2.70	1418	3.35	1663	3.95	1833	4.60	1966	5.25	2060	5.85	2117	6.50	2174

HEAT operation(230V)

MCFH-GA60VB : MUCFH-GA60VB

CAPACITY :6.8(kW) INPUT :2720(W)

INDOOR DB(°C)	OUTDOOR WB(°C)													
	-10		-5		0		5		10		15		20	
	Q	INPUT	Q	INPUT	Q	INPUT	Q	INPUT	Q	INPUT	Q	INPUT	Q	INPUT
15	4.28	1768	5.17	2122	6.05	2394	6.94	2584	7.82	2747	8.64	2829	9.52	2883
21	4.08	1904	4.90	2258	5.78	2502	6.60	2693	7.48	2829	8.30	2910	9.15	3019
26	3.67	2040	4.56	2394	5.37	2638	6.26	2829	7.14	2965	7.96	3046	8.84	3128

NOTE Q :Total capacity (kW) INPUT:Total power input (W) DB : Dry-bulb temperature WB : Wet-bulb temperature

9

ACTUATOR CONTROL

MUCFH-GA35VB MUCFH-GA50VB MUCFH-GA60VB

R.V. coil control

Heating ON
 Cooling OFF
 Dry OFF

NOTE. : The 4-way valve reverses for 5 seconds right before start-up of the compressor.

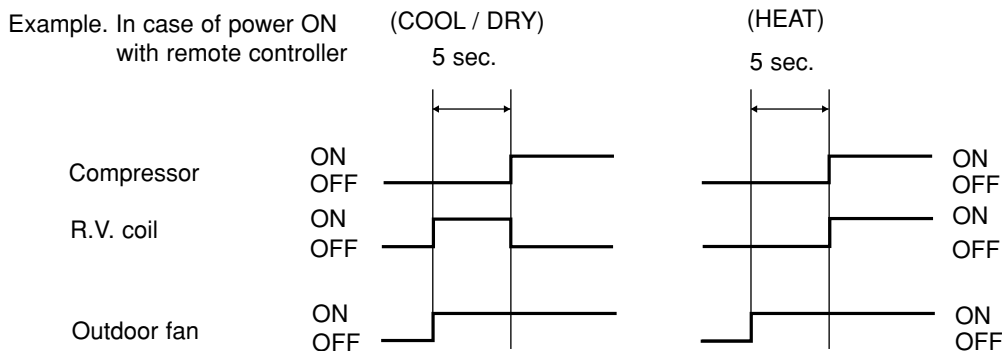

10

SERVICE FUNCTIONS

MUCFH-GA35VB MUCFH-GA50VB MUCFH-GA60VB

10-1. COMPULSORY DEFROSTING MODE FOR SERVICE

By short circuit of the connector JPDS and JPSG (MUCFH-GA35VB/GA50VB) / JPG1 and R871 (MUCFH-GA60VB) on the outdoor deicer P.C. board, defrosting mode can be accomplished regardless of the defrost interval restriction. Defrost thermistor RT61 must read below -3°C. (Refer to 11-5.)

10-2. CHANGE IN DEFROST SETTING

<JRF> When the JRF wire of the deicer P.C. board is cut, the defrost interval time will be changed.
 <JRG> When the JRG wire of the deicer P.C. board is cut, the defrost temperature will be changed.
 (Refer to 11-5.)

Model	Jumper wire	Change point
MUCFH-GA35VB	JRF	Defrost interval time changes from 40 minutes to 15 minutes.
MUCFH-GA50VB	JRG	Defrost start temperature changes from -3°C to 0°C. (MUCFH-GA35VB/GA50VB)
MUCFH-GA60VB		Defrost start temperature does not change. (-3.0°C) (MUCFH-GA60VB)
MUCFH-GA35VB		Defrost finish temperature changes 10.1°C. (MUCFH-GA35VB)
MUCFH-GA50VB		Defrost finish temperature changes from 3.1°C to 10.1°C. (MUCFH-GA50VB)
MUCFH-GA60VB		Defrost finish temperature changes from 3.1°C to 15°C. (MUCFH-GA60VB)

MUCFH-GA35VB MUCFH-GA50VB MUCFH-GA60VB
11-1. CAUTIONS ON TROUBLESHOOTING
1. Before troubleshooting, check the following:

- (1) Check the power supply voltage.
- (2) Check the indoor/outdoor connecting wire for mis-wiring.

2. Take care the following during service.

- (1) Before servicing the air conditioner, be sure to turn OFF the main unit first with the remote controller, and then after confirming the horizontal vane has completely closed, turn OFF the breaker.
- (2) Be sure to unplug the power cord before removing the air inlet grille, the front panel, the cabinet, the top panel and the electronic control P.C. boards.
- (3) When removing the electronic control P.C. board, hold the edge of the board with care NOT to apply stress on the components.
- (4) When connecting or disconnecting the connectors, hold the housing of the connector. DO NOT pull the lead wires.

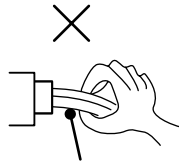

Lead wiring

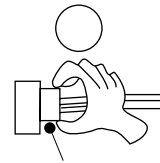

Housing point

3. Troubleshooting procedure

- (1) First, check if the OPERATION INDICATOR lamp on the indoor unit is flashing on and off to indicate an abnormality. To make sure, check how many times the abnormality indication is flashing on and off before starting service work.
- (2) If the electronic control P.C. board is supposed to be defective, check the copper foil pattern for disconnection and the components for bursting and discoloration.
- (3) When troubleshooting, refer to 11-2. "Instruction of troubleshooting".

11-2. INSTRUCTION OF TROUBLESHOOTING

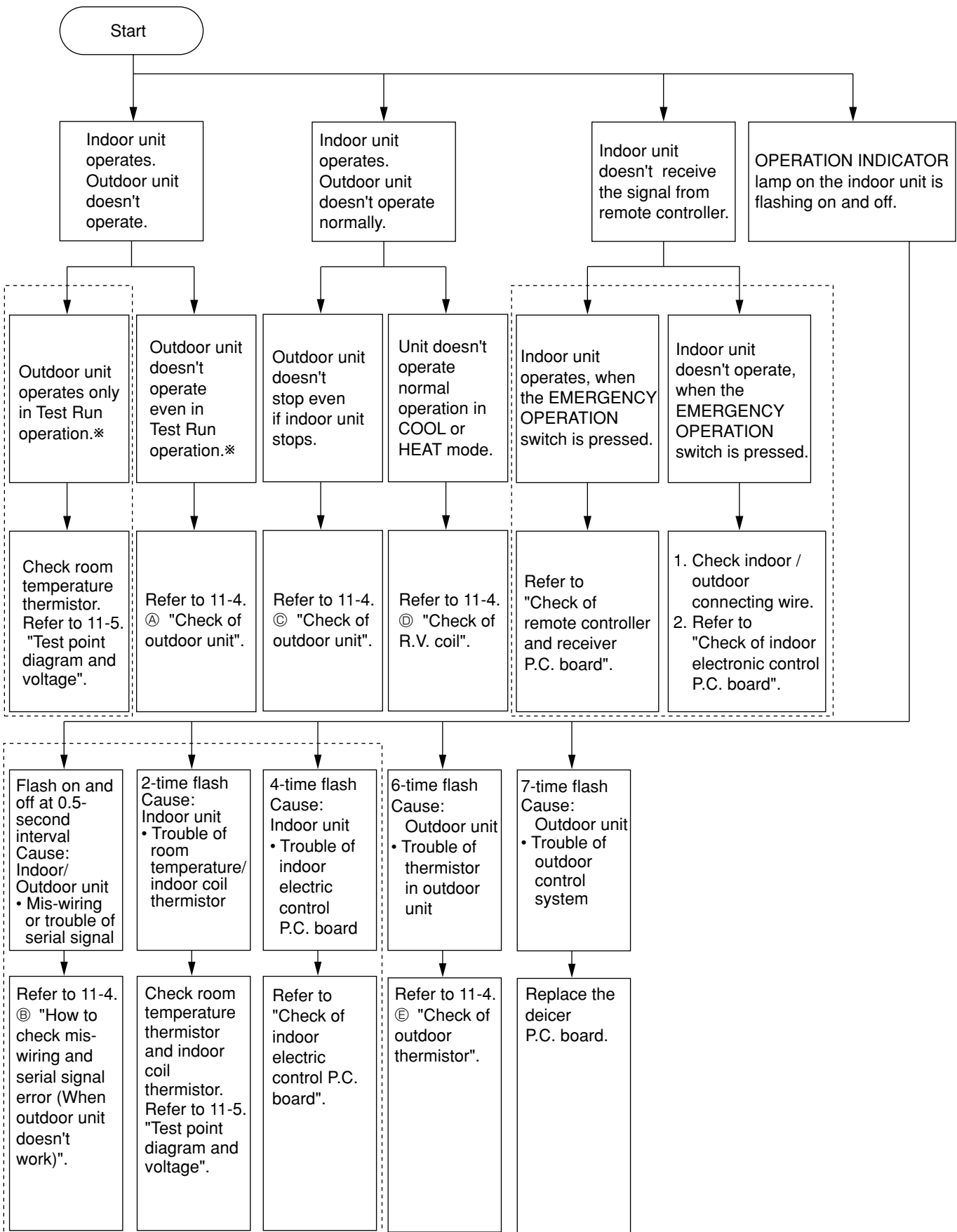

Refer to indoor unit service manual.

* "Test Run operation" means the operation within 30 minutes after EMERGENCY OPERATION switch is pressed.

11-3. TRUBLE CRITERION OF MAIN PARTS
MUCFH-GA35VB MUCFH-GA50VB MUCFH-GA60VB

Part name	Check method and criterion	Figure																									
Defrost thermistor (RT61)	Measure the resistance with a tester. (Part temperature -10°C ~ 40°C) <table border="1" style="margin-left: 20px;"> <thead> <tr> <th>Normal</th> <th>Abnormal</th> </tr> </thead> <tbody> <tr> <td>5kΩ ~ 60kΩ</td> <td>Open or short-circuit</td> </tr> </tbody> </table>	Normal	Abnormal	5kΩ ~ 60kΩ	Open or short-circuit																						
Normal	Abnormal																										
5kΩ ~ 60kΩ	Open or short-circuit																										
Compressor (MC) INNER PROTECTOR MUCFH-GA35VB 155± 5°C OPEN 90±10°C CLOSE MUCFH-GA50VB /GA60VB 160± 5°C OPEN 90±10°C CLOSE	Measure the resistance between the terminals with a tester. (Part temperature -10°C ~ 40°C) <table border="1" style="margin-left: 20px;"> <thead> <tr> <th rowspan="2">Color of lead wire</th> <th colspan="3">Normal</th> <th rowspan="2">Abnormal</th> </tr> <tr> <th>MUCFH-GA35VB</th> <th>MUCFH-GA50VB</th> <th>MUCFH-GA60VB</th> </tr> </thead> <tbody> <tr> <td>C-R</td> <td>2.46 ~ 3.01Ω</td> <td>1.05 ~ 1.30Ω</td> <td>0.84 ~ 1.04Ω</td> <td rowspan="2">Open or short-circuit</td> </tr> <tr> <td>C-S</td> <td>2.96 ~ 3.63Ω</td> <td>2.38 ~ 2.92Ω</td> <td>1.82 ~ 2.24Ω</td> </tr> </tbody> </table>	Color of lead wire	Normal			Abnormal	MUCFH-GA35VB	MUCFH-GA50VB	MUCFH-GA60VB	C-R	2.46 ~ 3.01Ω	1.05 ~ 1.30Ω	0.84 ~ 1.04Ω	Open or short-circuit	C-S	2.96 ~ 3.63Ω	2.38 ~ 2.92Ω	1.82 ~ 2.24Ω									
Color of lead wire	Normal			Abnormal																							
	MUCFH-GA35VB	MUCFH-GA50VB	MUCFH-GA60VB																								
C-R	2.46 ~ 3.01Ω	1.05 ~ 1.30Ω	0.84 ~ 1.04Ω	Open or short-circuit																							
C-S	2.96 ~ 3.63Ω	2.38 ~ 2.92Ω	1.82 ~ 2.24Ω																								
Outdoor fan motor (MF) MUCFH-GA35VB INNER FUSE 145±2°C CUT OFF MUCFH-GA50VB /GA60VB INNER PROTECTOR 145± 8°C OPEN (88±15°C CLOSE*)	Measure the resistance between the terminals with a tester. (Part temperature -10°C ~ 40°C) <table border="1" style="margin-left: 20px;"> <thead> <tr> <th rowspan="2">Color of lead wire</th> <th colspan="3">Normal</th> <th rowspan="2">Abnormal</th> </tr> <tr> <th>MUCFH-GA35VB</th> <th>MUCFH-GA50VB</th> <th>MUCFH-GA60VB</th> </tr> </thead> <tbody> <tr> <td>WHT-BLK</td> <td>191 ~ 231 Ω</td> <td>70 ~ 86 Ω</td> <td>61 ~ 74 Ω</td> <td rowspan="4">Open or short-circuit</td> </tr> <tr> <td>BLK-RED</td> <td>272 ~ 330 Ω</td> <td>74 ~ 89 Ω</td> <td>83 ~ 100 Ω</td> </tr> <tr> <td>BLK-YLW</td> <td>—</td> <td>—</td> <td>—</td> </tr> <tr> <td>YLW-RED</td> <td>—</td> <td>—</td> <td>—</td> </tr> </tbody> </table>	Color of lead wire	Normal			Abnormal	MUCFH-GA35VB	MUCFH-GA50VB	MUCFH-GA60VB	WHT-BLK	191 ~ 231 Ω	70 ~ 86 Ω	61 ~ 74 Ω	Open or short-circuit	BLK-RED	272 ~ 330 Ω	74 ~ 89 Ω	83 ~ 100 Ω	BLK-YLW	—	—	—	YLW-RED	—	—	—	<p>MUCFH-GA35VB</p> <p>MUCFH-GA50VB</p> <p>MUCFH-GA60VB</p>
Color of lead wire	Normal			Abnormal																							
	MUCFH-GA35VB	MUCFH-GA50VB	MUCFH-GA60VB																								
WHT-BLK	191 ~ 231 Ω	70 ~ 86 Ω	61 ~ 74 Ω	Open or short-circuit																							
BLK-RED	272 ~ 330 Ω	74 ~ 89 Ω	83 ~ 100 Ω																								
BLK-YLW	—	—	—																								
YLW-RED	—	—	—																								
R.V. coil (21S4)	Measure the resistance using a tester. (Part temperature -10°C ~ 40°C) <table border="1" style="margin-left: 20px;"> <thead> <tr> <th>Normal</th> <th>Abnormal</th> </tr> </thead> <tbody> <tr> <td>1.94 kΩ ~ 2.39 kΩ</td> <td>Open or short-circuit</td> </tr> </tbody> </table>	Normal	Abnormal	1.94 kΩ ~ 2.39 kΩ	Open or short-circuit																						
Normal	Abnormal																										
1.94 kΩ ~ 2.39 kΩ	Open or short-circuit																										

* Reference value

Ⓟ : INNER PROTECTOR

11-4. TROUBLESHOOTING FLOW

Compressor and/or outdoor fan motor doesn't operate.

Ⓐ Check of outdoor unit

MUCFH-GA35VB

MUCFH-GA50VB

Operate the unit in COOL or HEAT mode by pressing the EMERGENCY OPERATION switch.
3-minute time delay works.
Test run operation operates for 30 minutes.

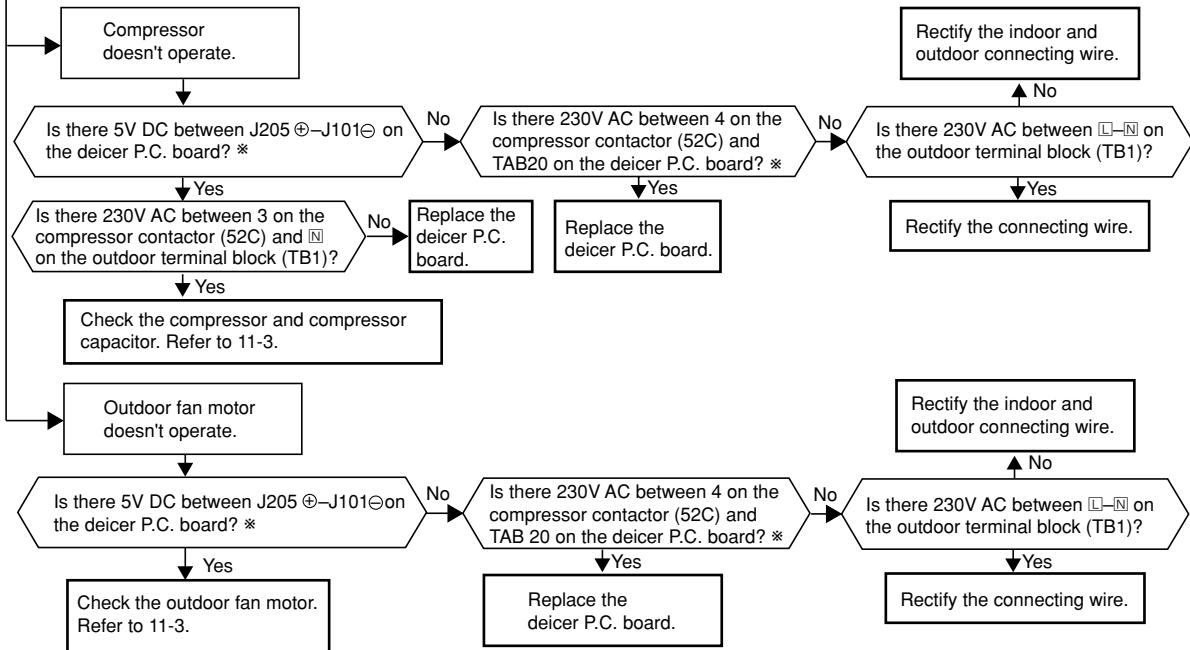

* Refer to 11-5.

Compressor and/or outdoor fan motor doesn't operate.

A Check of outdoor unit

MUCFH-GA60VB

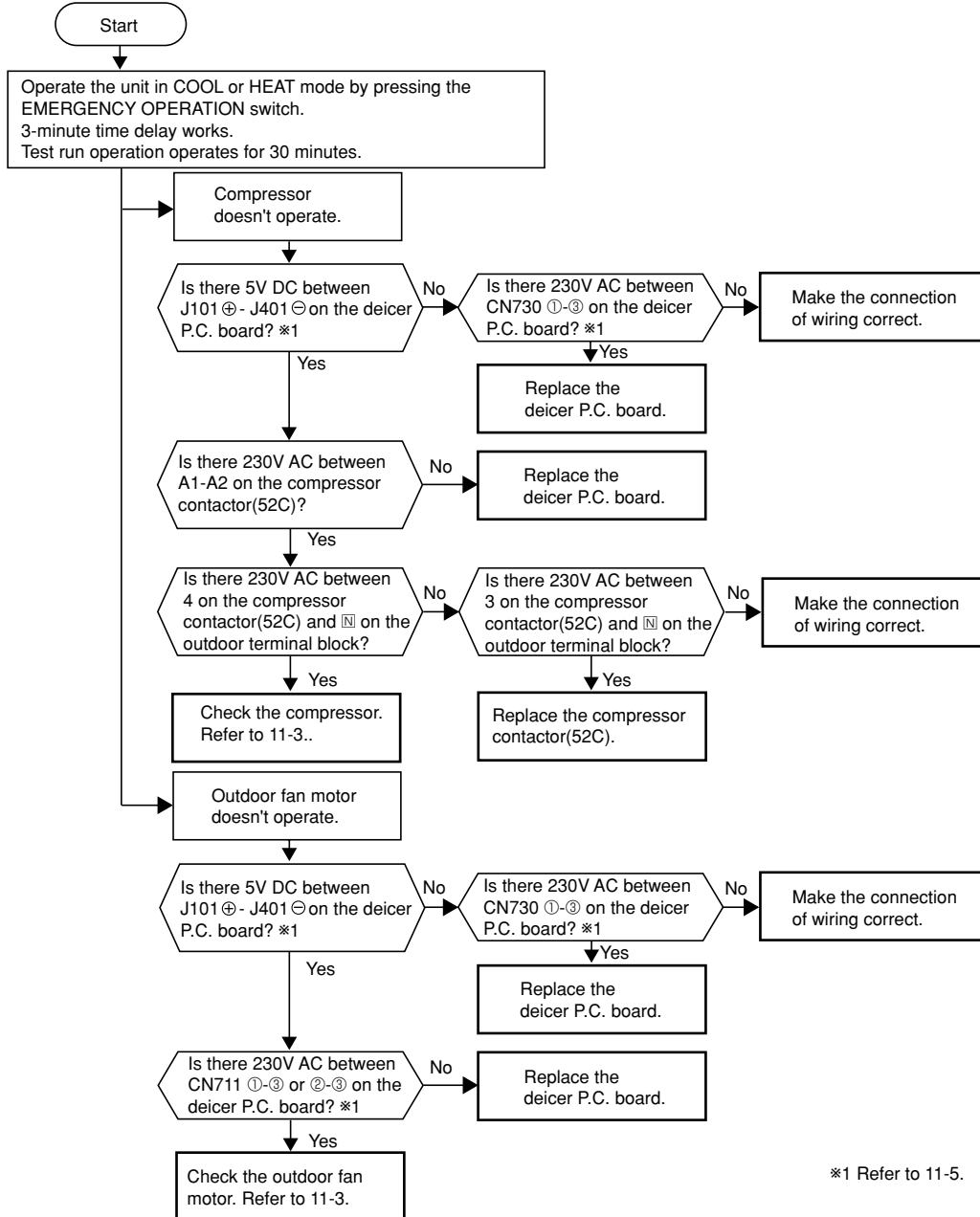

When OPERATION INDICATOR lamp flashes ON and OFF in every 0.5-second.
Outdoor unit does not operate.

Ⓑ How to check mis-wiring and serial signal error (when outdoor unit does not work)

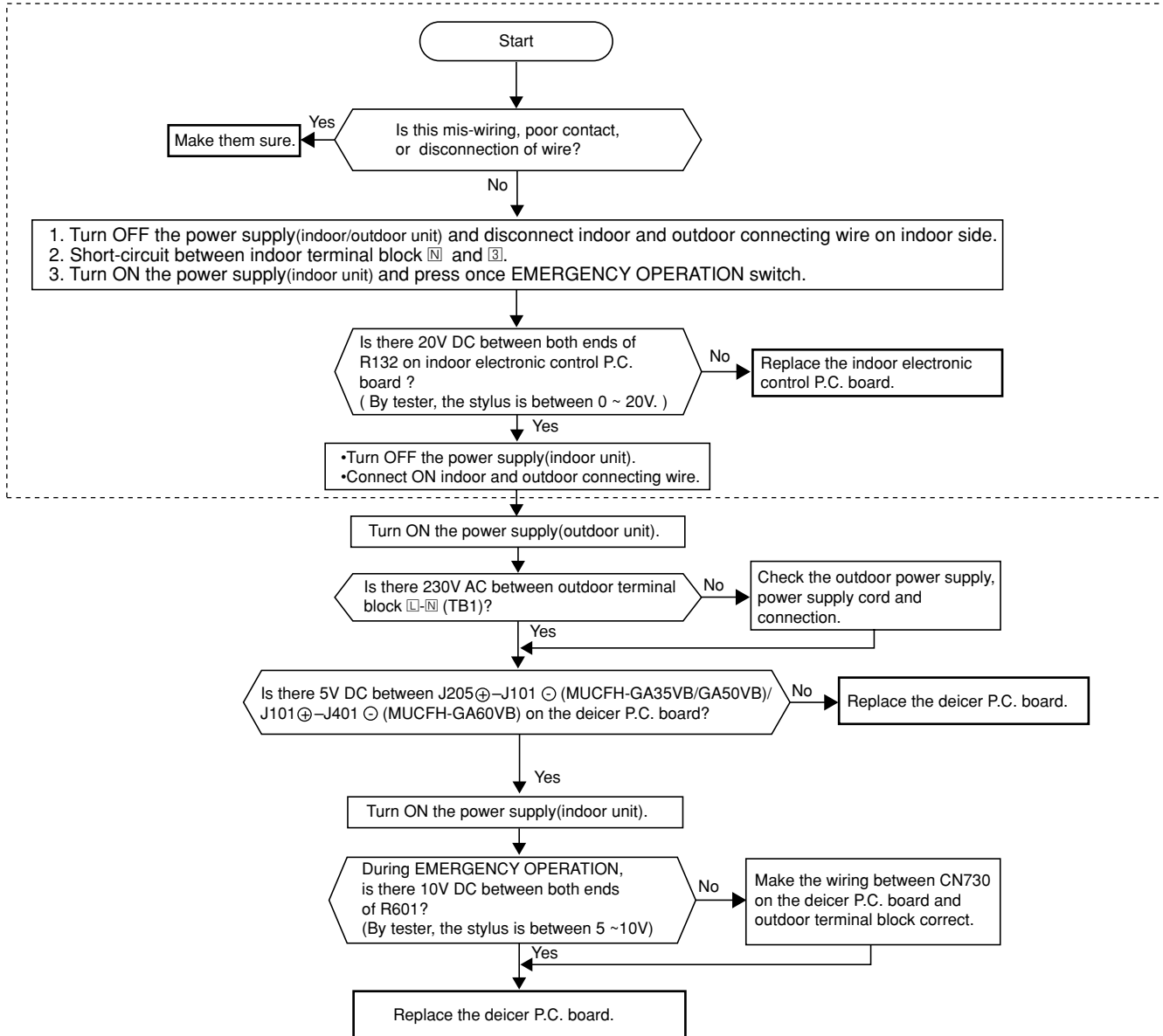

Refer to indoor unit service manual.

Compressor and/or outdoor fan motor doesn't stop.

Ⓒ Check of outdoor unit

MUCFH-GA35VB MUCFH-GA50VB

- ① Turn OFF the power supply.
- ② After 30 seconds, turn ON the power supply again.
- ③ Operate the unit in COOL or HEAT mode by pressing the EMERGENCY OPERATION switch.
- ④ Operate the unit for 1 minute or more and stop it by pressing the EMERGENCY OPERATION switch again.

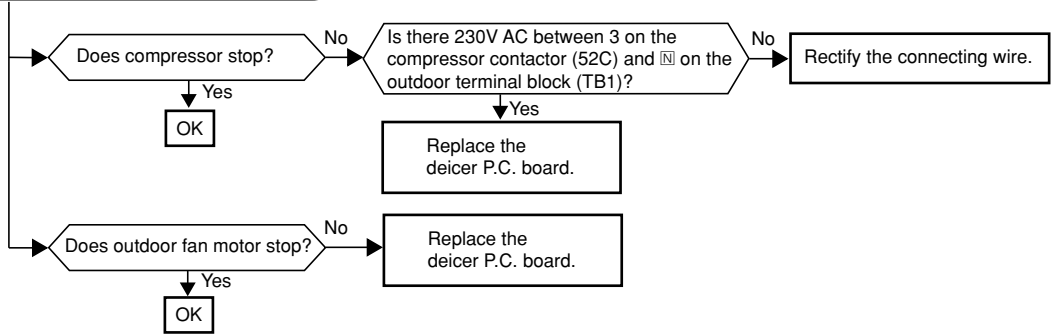

MUCFH-GA60VB

- ① Turn OFF the power supply.
- ② After 30 seconds, turn ON the power supply again.
- ③ Operate the unit in COOL or HEAT mode by pressing the EMERGENCY OPERATION switch.
- ④ Operate the unit for 1 minute or more and stop it by pressing the EMERGENCY OPERATION switch again.

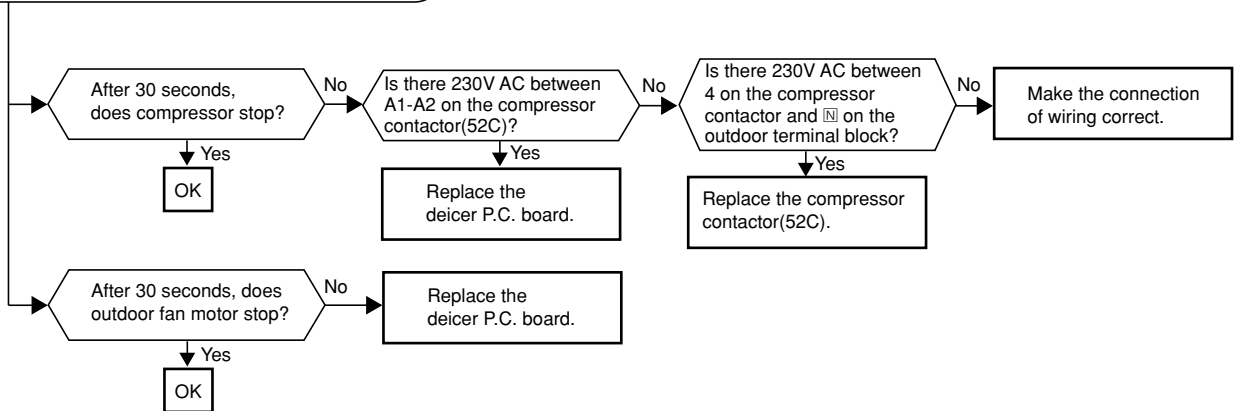

Unit operates HEAT mode even if it is set to COOL mode.

Ⓓ Check of R.V. coil

* First, measure the resistance of R.V. coil to confirm it is disconnected or is not short-circuit.

Disconnect the TAB52 on the deicer P.C. board. (MUCFH-GA60VB)
Turn ON the power supply and operate the indoor unit in COOL mode by pressing the EMERGENCY OPERATION switch.

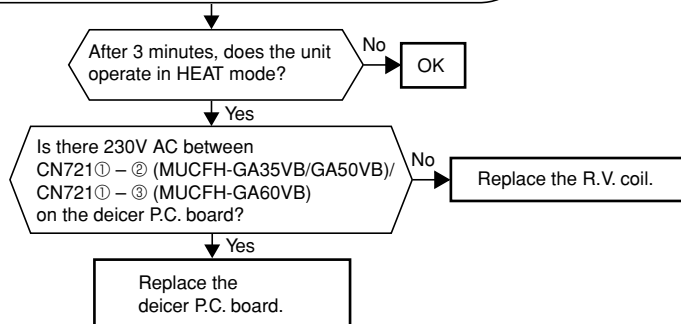

Unit operates COOL mode even if it is set to HEAT mode.

④ Check of R.V. coil

* First, measure the resistance of R.V. coil to confirm it is disconnected or is not short-circuit.

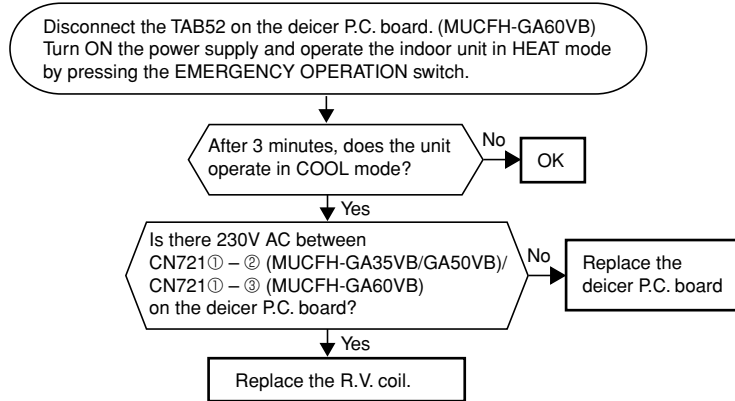

**When OPERATION INDICATOR lamp flashes 6-time.
Thermistors in the outdoor unit are abnormal.**

⑤ Check of outdoor thermistor

* Disconnect the connectors CN661 from the deicer P.C. board.
(Check the characteristics of each thermistor.)

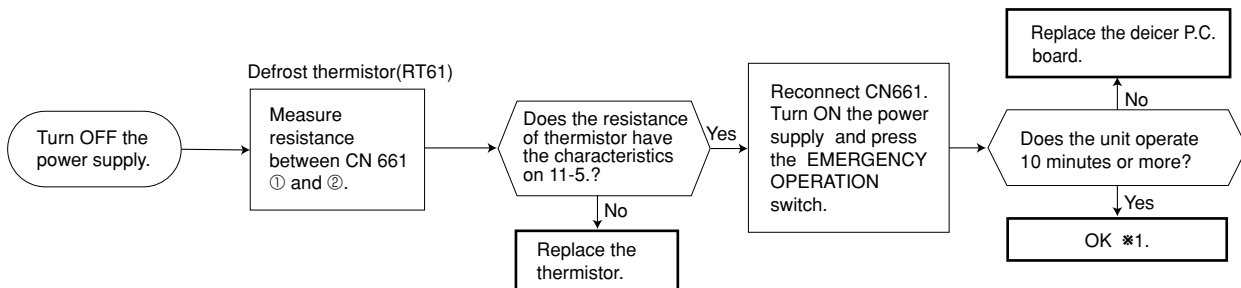

*1. It is thought defective contact of the connector.

11-5. TEST POINT DIAGRAM AND VOLTAGE

MUCFH-GA35VB

MUCFH-GA50VB

Outdoor deicer P.C. board

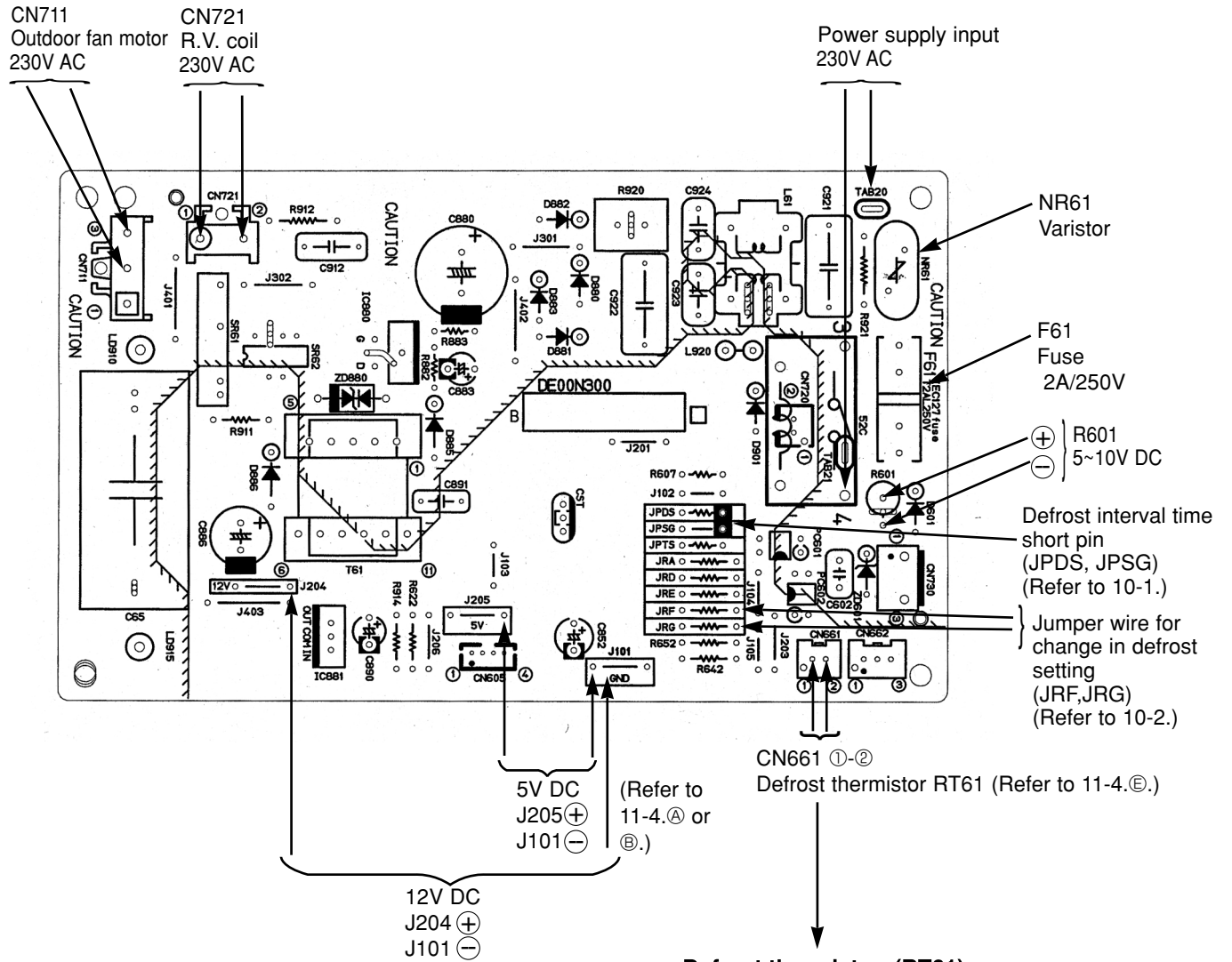

Defrost thermistor (RT61)

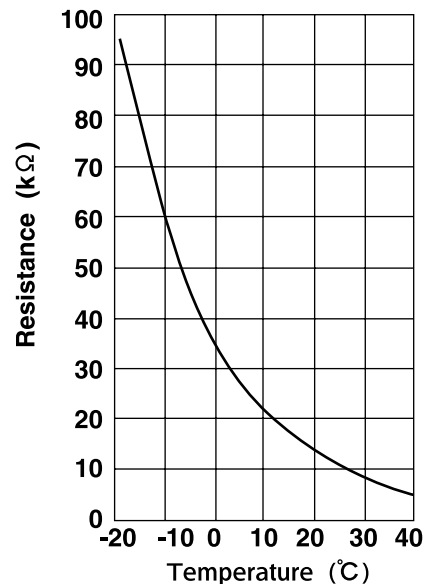

MUCFH-GA60VB

Outdoor deicer P.C. board

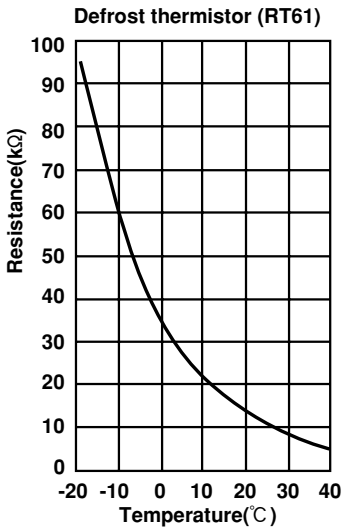

CN661 ①-②
 Defrost thermistor (RT61)
 (Refer to 11-4.Ⓔ.)

Fan motor
 (CN711) 230V
 Varistor
 (NR62)

Defrost interval
 time short
 pin(JPG1,
 R871)
 (Refer to
 10-1.)

J101 (+)
 5V
 DC
 J401 (-)
 (Refer to
 11-4.Ⓐ or
 Ⓑ.)

Jumper wire for
 change in defrost
 setting (JRF, JRG)
 (Refer to 10-2.)

R.V. coil
 (CN721)
 230V

12V DC

Fuse (F61)
 3.15A / 250V

Varistor
 (NR61)

Power supply
 input
 CN730 ①-③
 230V AC
 (Refer to
 11-4.Ⓐ.)

R601
 10V DC
 (Refer to
 11-4.Ⓔ.)

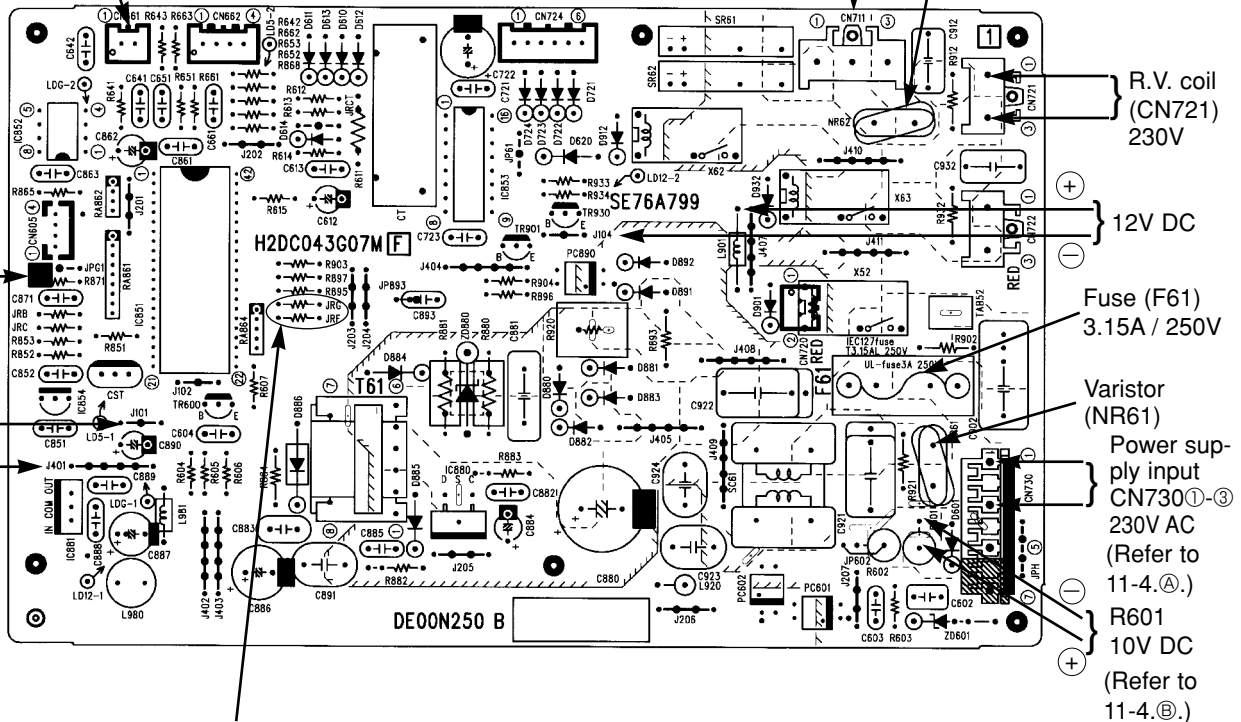

<"Terminal with locking mechanism" Detaching points>

The terminal which has the locking mechanism can be detached as shown below. There are two types (Refer to (1) and (2)) of the terminal with locking mechanism. The terminal without locking mechanism can be detached by pulling it out. Check the shape of the terminal before detaching.

(1) Slide the sleeve and check if there is a locking lever or not.

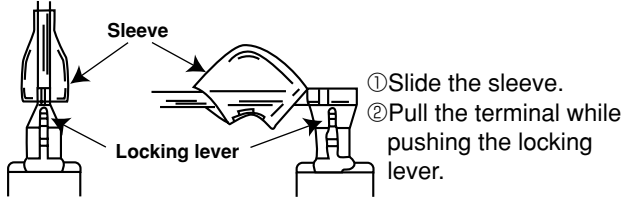

(2) The terminal with this connector has the locking mechanism.

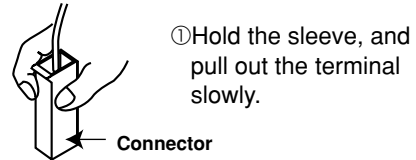

12-1. MUCFH-GA35VB

OPERATING PROCEDURE	PHOTOS
<p>1. Removing the cabinet</p> <ol style="list-style-type: none"> (1) Remove the screws of the top panel. (2) Remove the screw of the service panel. (3) Remove the screws of the cabinet. (4) Remove the screws of the front panel and motor support. (5) Remove the service panel, and remove the screw from the insides. (6) Remove the top panel. (7) Remove the cabinet. <p>Photo 3</p> <p>Screws of the service panel Screws of the top panel</p> <p>Service panel</p>	<p>Photo 1</p> <p>Screws of the front panel and motor support</p> <p>Screws of the cabinet</p> <p>Screws of the cabinet</p> <p>Photo 2</p> <p>Screw of the top panel</p> <p>Screws of the cabinet</p>

OPERATING PROCEDURE

2. Removing the deicer P.C. board

- (1) Remove the service panel and the cabinet.
- (2) Disconnect all the connectors and the terminals on the deicer P.C. board.
- (3) Remove the deicer P.C. board.

PHOTOS

Photo 4

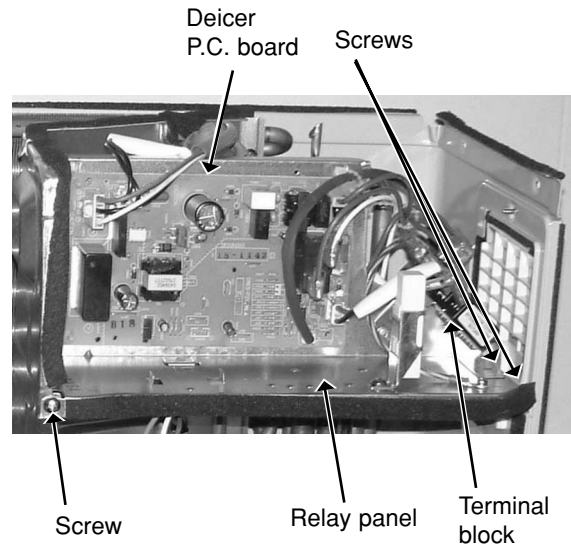

3. Removing the propeller and the outdoor fan motor

- (1) Remove the cabinet. (Refer to 1.)
- (2) Remove the propeller nut.
- (3) Remove the propeller.

NOTE : Loose the propeller in the rotating direction for removal.

When attaching the propeller, align the mark on the propeller and the motor shaft cut section.

Set the propeller in position by using the cut on the shaft and the mark on the propeller.

- (4) Remove lead clamps and disconnect the outdoor fan motor connector.
- (5) Remove screws fixing the fan motor.
- (6) Remove the outdoor fan motor.

Photo 5

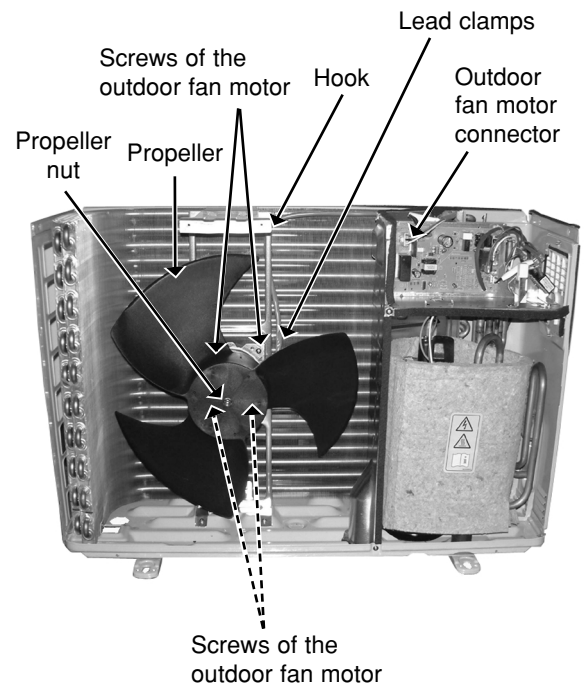

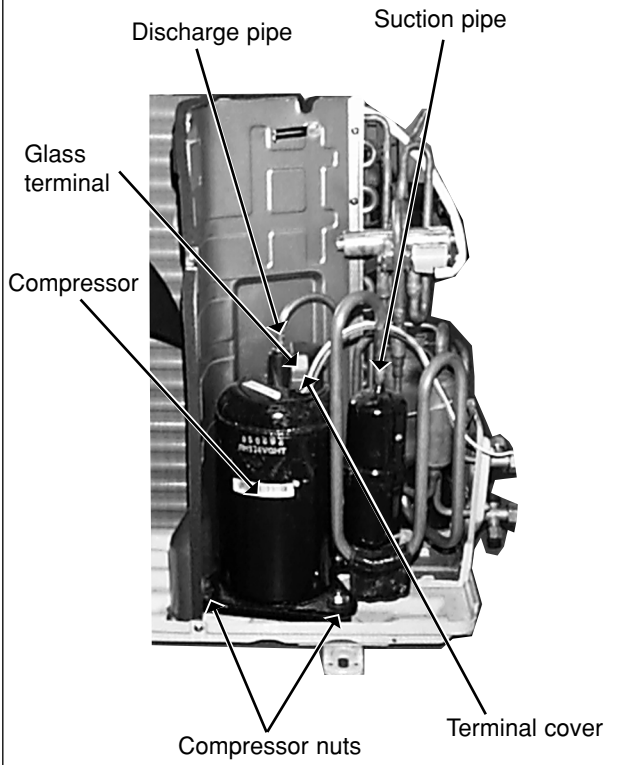

OPERATING PROCEDURE	PHOTOS
<p>4. Removing the compressor</p> <ol style="list-style-type: none">(1) Remove the cabinet. (Refer to 1.)(2) Remove the relay panel.(3) Remove the soundproof felt.(4) Remove the terminal cover on the compressor.(5) Disconnect lead wires from the glass terminal of the compressor.(6) Recover gas from the refrigerant circuit. <p>NOTE : Recover gas from the pipes until the pressure gauge shows 0 kg/cm² (0 MPa).</p> <ol style="list-style-type: none">(7) Disconnect the welded part of the discharge pipe.(8) Disconnect the welded part of the suction pipe.(9) Remove nuts fixing the compressor.(10) Remove the compressor.	<p>Photo 6</p>  <p>Discharge pipe Suction pipe</p> <p>Glass terminal</p> <p>Compressor</p> <p>Compressor nuts Terminal cover</p>

12-2. MUCFH-GA50VB

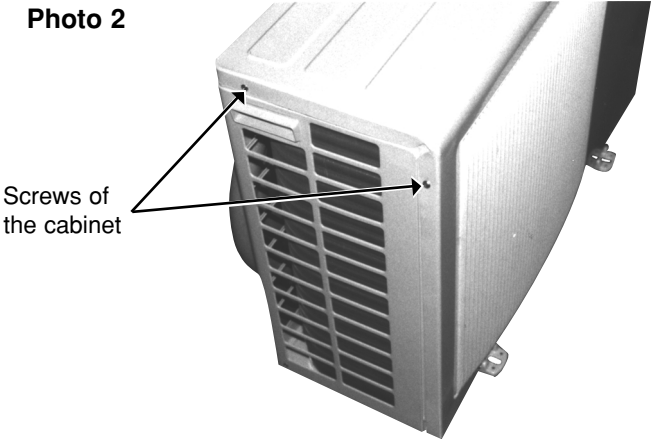
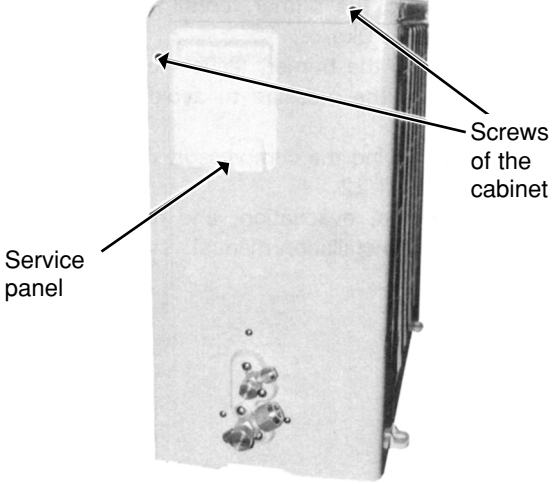
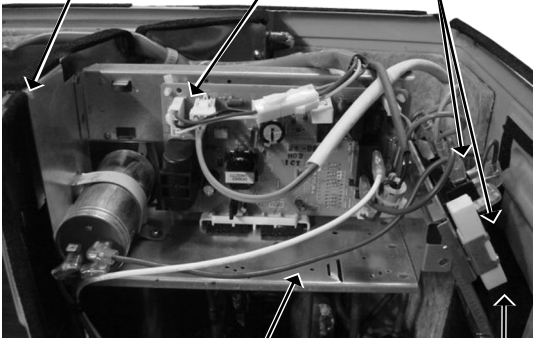
OPERATING PROCEDURE	PHOTOS
<p>1. Removing the cabinet</p> <p>(1) Remove the screws of the cabinet.</p> <p>(2) Hold the bottom of the cabinet on both sides and remove the cabinet.</p> <p>Photo 2</p>  <p>Screws of the cabinet</p>	<p>Photo 1</p>  <p>Service panel</p> <p>Screws of the cabinet</p>
<p>2. Removing the deicer P.C. board</p> <p>(1) Remove the service panel and the cabinet.</p> <p>(2) Disconnect all the connectors and the terminals on the deicer P.C. board.</p> <p>(3) Remove the deicer P.C. board.</p>	<p>Photo 3</p>  <p>Screw of the relay panel</p> <p>Deicer P.C. board</p> <p>Terminal blocks</p> <p>Relay panel</p> <p>Screw of the relay panel</p>



OPERATING PROCEDURE

3. Removing the propeller and the outdoor fan motor

- (1) Remove the cabinet. (Refer to 1.)
- (2) Remove the propeller nut and the propeller.

NOTE : Loose the propeller in the rotating direction for removal.

When attaching the propeller, align the mark on the propeller and the motor shaft cut section.

Set the propeller in position by using the cut on the shaft and the mark on the propeller.

- (3) Remove the clamp of outdoor fan motor lead wire and disconnect the outdoor fan motor connector.
- (4) Remove the screws fixing the outdoor fan motor.
- (5) Remove the outdoor fan motor.

PHOTOS

Photo 4

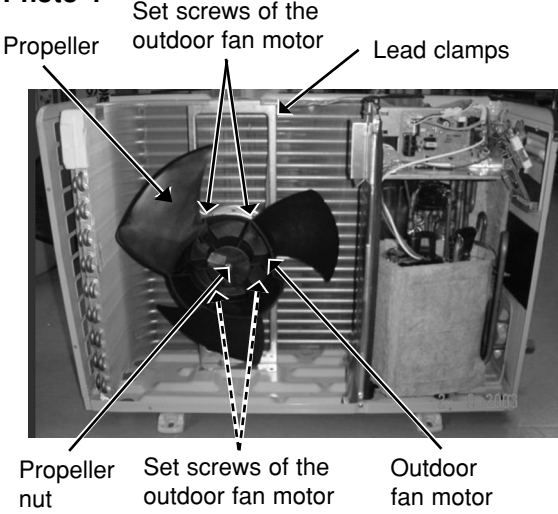

4. Removing the compressor

- (1) Remove the cabinet. (Refer to 1.)
- (2) Remove the relay panel.
- (3) Remove the soundproof felt.
- (4) Remove the terminal cover on the compressor.
- (5) Disconnect lead wires from the compressor.
- (6) Recover gas from the refrigerant circuit.

NOTE : Recover gas from the pipes until the pressure gauge shows 0 kg/cm² (0 MPa).

- (7) Disconnect the welded part of the discharge pipe.
- (8) Disconnect the welded part of the suction pipe.
- (9) Remove nuts fixing the compressor.
- (10) Remove the compressor.

Photo 5

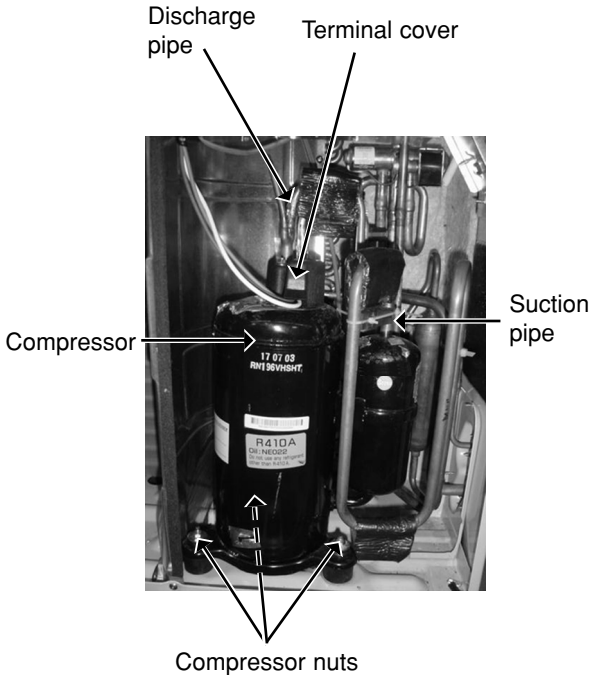

12-3. MUCFH-GA60VB

OPERATING PROCEDURE

1. Removing the cabinet

- (1) Remove the screws of the service panel.
- (2) Remove the screws of the top panel.
- (3) Remove the screw of the valve cover.
- (4) Remove the service panel.
- (5) Remove the top panel.
- (6) Remove the valve cover.
- (7) Remove the screws of the front panel.
- (8) Remove the front panel.
- (9) Remove the screws of the back panel.
- (10) Remove the back panel.

Photo 3

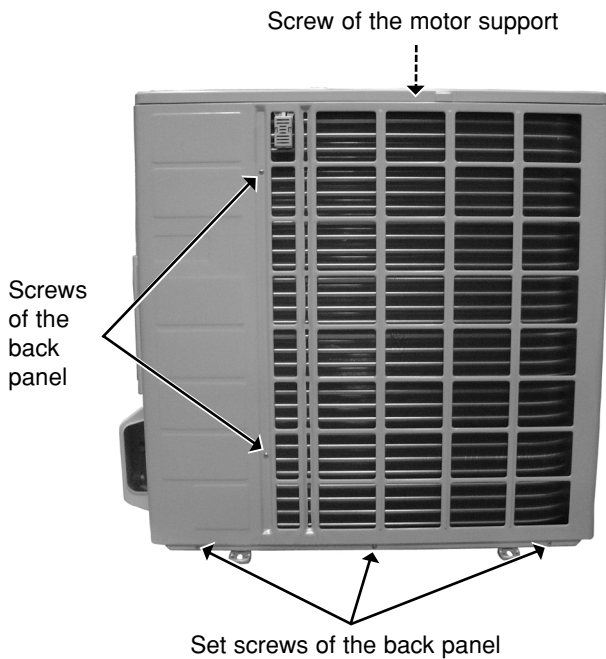

PHOTOS

Photo 1

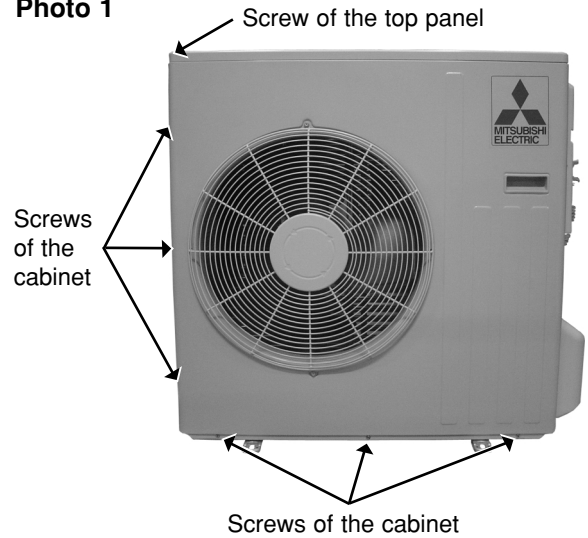
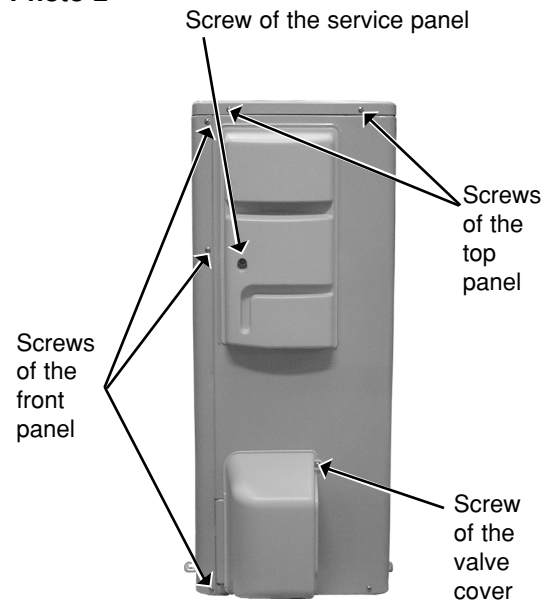

Photo 2



2. Removing the deicer P.C. board

- (1) Remove the service panel and the cabinet.
- (2) Disconnect all the connectors and the terminals on the deicer P.C. board.
- (3) Remove the deicer P.C. board.

Photo 4

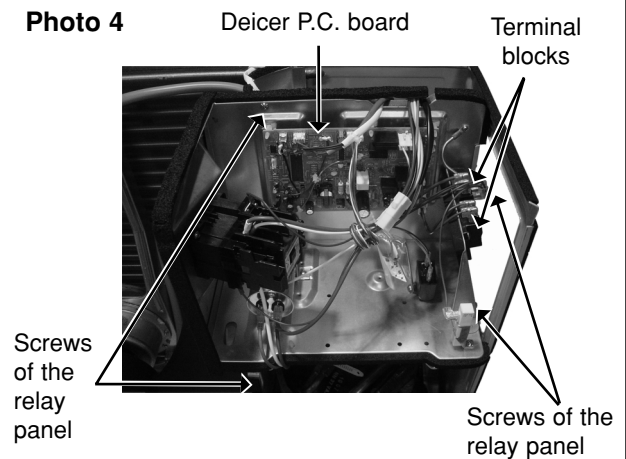



OPERATING PROCEDURE	PHOTOS
<p>3. Removing the propeller and the outdoor fan motor</p> <p>(1) Remove the cabinet. (Refer to 1.)</p> <p>(2) Remove the propeller nut and the propeller.</p> <p>NOTE : Loose the propeller in the rotating direction for removal.</p> <p>When attaching the propeller, align the mark on the propeller and the motor shaft cut section.</p> <p>Set the propeller in position by using the cut on the shaft and the mark on the propeller.</p> <p>(3) Remove the clamp of outdoor fan motor lead wire and disconnect the outdoor fan motor connector.</p> <p>(4) Remove the screws fixing the outdoor fan motor.</p> <p>(5) Remove the outdoor fan motor.</p>	<p>Photo 5</p> <p>Set screws of the outdoor fan motor</p> <p>Propeller nut</p> <p>Propeller</p> <p>Set screws of the outdoor fan motor</p>
<p>4. Removing the compressor</p> <p>(1) Remove the cabinet. (Refer to 1.)</p> <p>(2) Remove the relay panel.</p> <p>(3) Remove the soundproof felt.</p> <p>(4) Remove the terminal cover on the compressor.</p> <p>(5) Disconnect lead wires from the compressor.</p> <p>(6) Recover gas from the refrigerant circuit.</p> <p>NOTE : Recover gas from the pipes until the pressure gauge shows 0 kg/cm² (0 MPa).</p> <p>(7) Disconnect the welded part of the discharge pipe.</p> <p>(8) Disconnect the welded part of the suction pipe.</p> <p>(9) Remove nuts fixing the compressor.</p> <p>(10) Remove the compressor.</p>	<p>Photo 6</p> <p>Discharge pipe</p> <p>Suction pipe</p> <p>Terminal cover</p> <p>Compressor nuts</p>

MUCFH-GA35VB

13-1. OUTDOOR UNIT STRUCTURAL PARTS

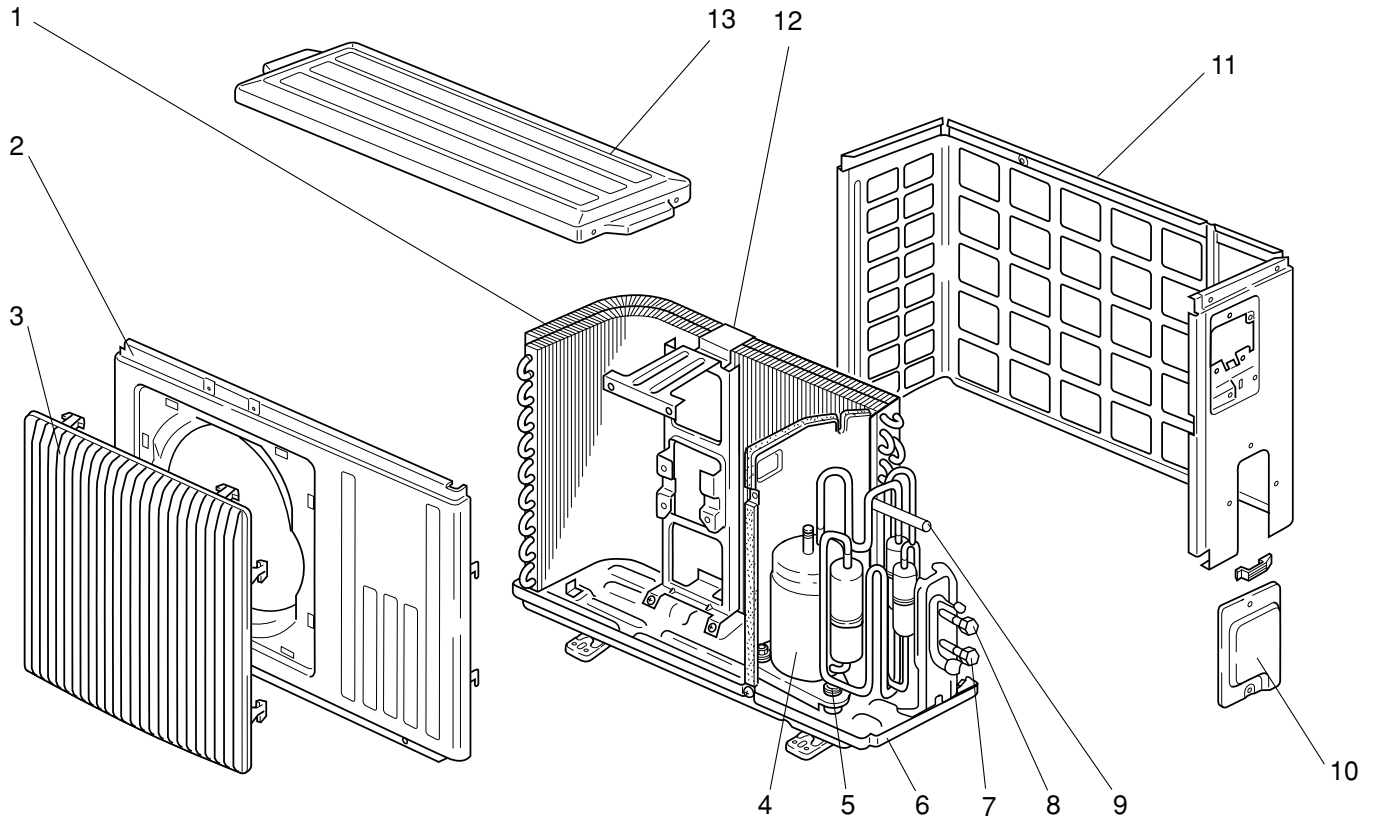

PARTS LIST (non-RoHS compliant)

MUCFH-GA35VB

13-1. OUTDOOR UNIT STRUCTURAL PARTS

Part numbers that are circled are not shown in the illustration.

No.	Part No.	Part name	Symbol in Wiring Diagram	Q'ty/unit	Remarks
				MUCFH-GA35VB- E1	
1	E02 837 630	OUTDOOR HEAT EXCHANGER		1	
2	E02 815 232	CABINET		1	
3	E02 815 521	GRILLE (OUT)		1	
4	E02 754 900	COMPRESSOR	MC	1	RN135VHSHT
5	E02 075 506	COMPRESSOR RUBBER SET		3	3RUBBERS/SET
6	E02 832 290	BASE		1	
7	E02 910 661	STOP VALVE (GAS)		1	φ12.7
8	E02 910 662	STOP VALVE (LIQUID)		1	φ6.35
9	E02 931 961	4-WAY VALVE		1	
10	E02 815 245	SERVICE PANEL		1	
11	E02 836 233	BACK PANEL		1	
12	E02 442 515	MOTOR SUPPORT		1	
13	E02 815 297	TOP PANEL		1	
⑭	E02 156 936	CAPILLARY TUBE		2	φ3.0xφ1.4x500
	E02 726 936	CAPILLARY TUBE		1	φ3.0xφ1.6x600
	E02 837 936	CAPILLARY TUBE		1	φ3.0xφ1.6x1050
⑮	E02 891 642	CHECK VALVE		1	

PARTS LIST (non-RoHS compliant)

MUCFH-GA35VB

13-2. OUTDOOR UNIT ELECTRICAL PARTS AND FUNCTIONAL PARTS

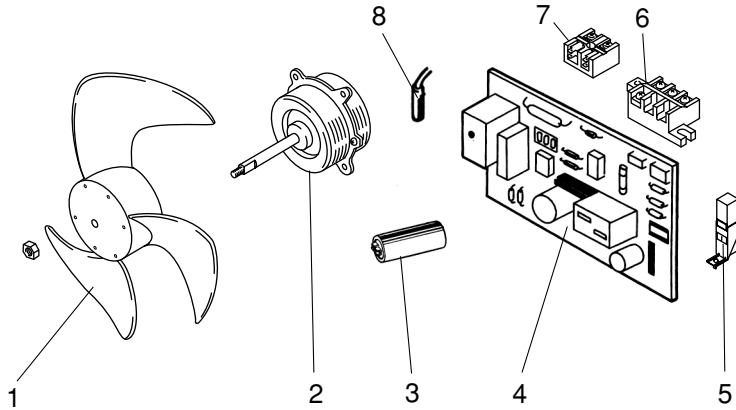

13-3. ACCESSORY

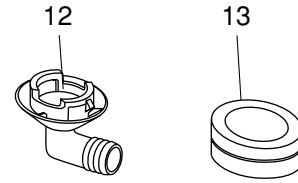

13-2. OUTDOOR UNIT ELECTRICAL PARTS AND FUNCTIONAL PARTS

Part numbers that are circled are not shown in the illustration.

No.	Part No.	Part name	Symbol in Wiring Diagram	Q'ty/unit	Remarks
				MUCFH-GA35VB- E1	
1	E02 665 501	PROPELLER		1	
2	E02 672 301	OUTDOOR FAN MOTOR	MF	1	RA6V33-□□
3	E02 696 353	COMPRESSOR CAPACITOR	C1	1	30 μ F /440V AC
4	E02 836 451	DEICER P.C. BOARD		1	
5	E02 890 383	SURGE ABSORBER	DSAR	1	
6	E02 817 374	TERMINAL BLOCK	TB1	1	3P
7	E02 836 374	TERMINAL BLOCK	TB2	1	2P
8	E02 699 310	DEFROST THERMISTOR	RT61	1	
⑨	E02 910 490	R. V. COIL	21S4	1	
⑩	E02 095 382	FUSE	F61	1	250V /2A
⑪	E02 820 385	VARISTOR	NR61	1	

13-3. ACCESSORY

12	E02 817 704	DRAIN SOCKET		1	
13	E02 444 705	DRAIN CAP		2	φ33 2PCS/SET

PARTS LIST (non-RoHS compliant)

MUCFH-GA50VB

13-4. OUTDOOR UNIT STRUCTURAL PARTS, ELECTRICAL PARTS AND FUNCTIONAL PARTS

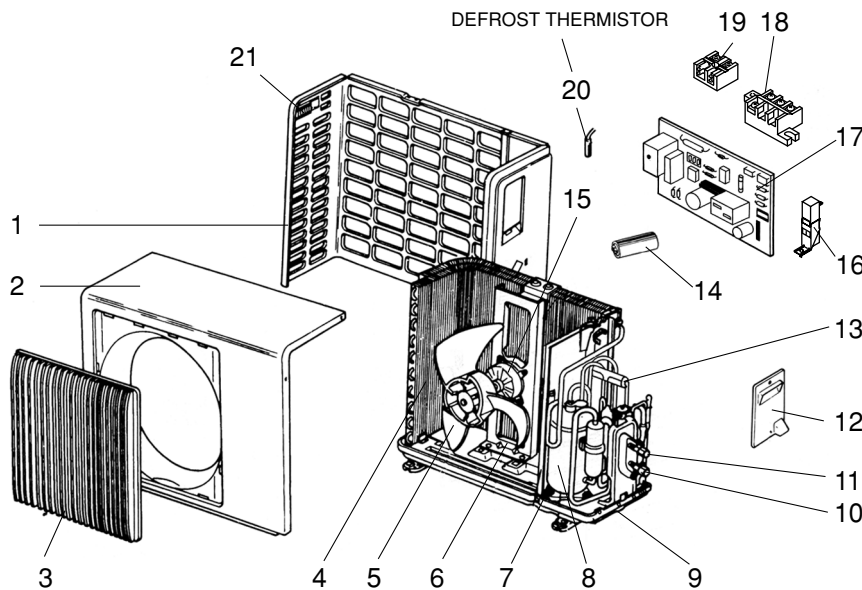

13-5. ACCESSORY

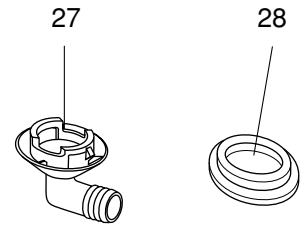

13-4. OUTDOOR UNIT STRUCTURAL PARTS, ELECTRICAL PARTS AND FUNCTIONAL PARTS

Part numbers that are circled are not shown in the illustration.

No.	Part No.	Part Name	Symbol in Wiring Diagram	Q'ty/unit		Remarks
					MUCFH-GA50VB- E1	
1	E02 817 233	BACK PANEL		1		
2	E02 817 232	CABINET		1		
3	E02 817 521	GRILLE		1		
4	E02 643 630	OUTDOOR HEAT EXCHANGER		1		
5	E02 141 501	PROPELLER		1		
6	E02 139 515	MOTOR SUPPORT		1		
7	E02 075 506	COMPRESSOR RUBBER SET		3		3RUBBERS/SET
8	E02 817 900	COMPRESSOR	MC	1		RN196VHSHT
9	E02 817 290	BASE		1		
10	E02 817 661	STOP VALVE (GAS)		1		φ12.7
11	E02 820 662	STOP VALVE (LIQUID)		1		φ 6.35
12	E02 817 245	SERVICE PANEL		1		
13	E02 891 961	4-WAY VALVE		1		
14	E02 888 353	COMPRESSOR CAPACITOR	C1	1		40μF/440V AC
15	E02 816 301	OUTDOOR FAN MOTOR	MF	1		RA6V50 - □□
16	E02 895 383	SURGE ABSORBER	DSAR	1		
17	E02 820 451	DEICER P.C. BOARD		1		
18	E02 817 374	TERMINAL BLOCK	TB1	1		3P
19	E02 821 374	TERMINAL BLOCK	TB2	1		2P
20	E02 820 310	DEFROST THERMISTOR	RT61	1		
21	E02 817 009	HANDLE		1		
22	E02 139 936	CAPILLARY TUBE		2		φ3.0×φ1.6×750
	E02 746 937	CAPILLARY TUBE		1		φ3.0×φ1.6×650
	E02 289 937	CAPILLARY TUBE		1		φ3.0×φ1.6×500
	E02 820 936	CAPILLARY TUBE		1		φ2.5×φ0.6×1000
23	E02 095 382	FUSE	F61	1		250V / 2A
24	E02 821 490	R.V. COIL	21S4	1		
25	E02 891 642	CHECK VALVE		1		
26	E02 820 385	VARISTOR	NR61	1		

13-5. ACCESSORY

27	E02 817 704	DRAIN SOCKET		1		
28	E02 444 705	DRAIN CAP		2		φ33 2PCS/SET
	E02 444 706	DRAIN CAP		1		φ16

PARTS LIST (non-RoHS compliant)

MUCFH-GA60VB

13-6. OUTDOOR UNIT STRUCTURAL PARTS, ELECTRICAL PARTS AND FUNCTIONAL PARTS

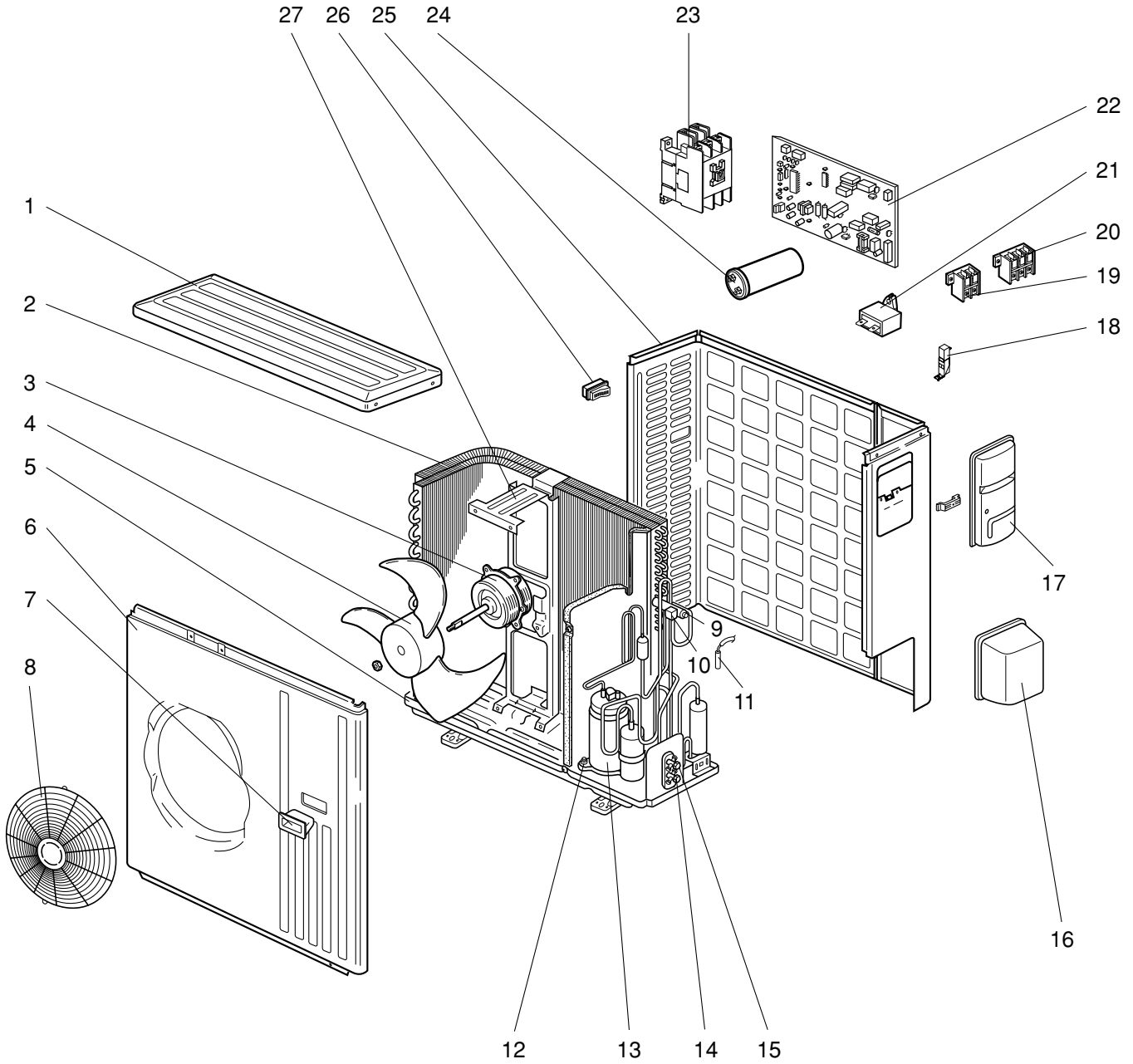

13-7. ACCESSORY

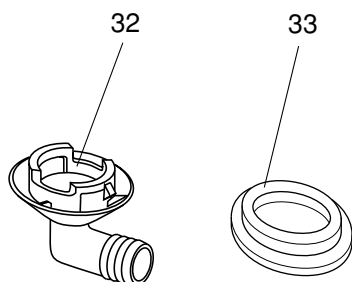

PARTS LIST (non-RoHS compliant)

MUCFH-GA60VB

13-6. OUTDOOR UNIT STRUCTURAL PARTS, ELECTRICAL PARTS AND FUNCTIONAL PARTS

Part numbers that are circled are not shown in the illustration.

No.	Part No.	Part Name	Symbol in Wiring Diagram	Q'ty/unit	Remarks
				MUCFH-GA60VB - E1	
1	E02 819 297	TOP PANEL		1	
2	E02 821 630	OUTDOOR HEAT EXCHANGER		1	
3	E02 892 301	OUTDOOR FAN MOTOR	MF	1	RA6V85- □□
4	E02 214 501	PROPELLER		1	
5	E02 821 290	BASE		1	
6	E02 819 232	CABINET		1	
7	E02 819 009	HANDLE		1	
8	E02 819 521	FAN GUARD		1	
9	E02 891 961	4-WAY VALVE		1	
10	E02 821 490	R.V. COIL	21S4	1	
11	E02 821 310	DEFROST THERMISTOR	RT61	1	
12	E02 527 506	COMPRESSOR RUBBER SET		4	4RUBBERS/SET
13	E02 821 900	COMPRESSOR	MC	1	NN29VBAHT
14	E02 819 661	STOP VALVE (GAS)		1	φ15.88
15	E02 821 662	STOP VALVE (LIQUID)		1	φ6.35
16	E02 819 650	VALVE COVER		1	
17	E02 819 245	SERVICE PANEL		1	
18	E02 890 383	SURGE ABSORBER	DSAR	1	
19	E02 821 374	TERMINAL BLOCK	TB2	1	2P
20	E02 817 374	TERMINAL BLOCK	TB1	1	3P
21	E02 895 351	OUTDOOR FAN CAPACITOR	C2	1	3.0μF/440V AC
22	E02 912 451	DEICER P.C. BOARD		1	
23	E07 012 340	COMPRESSOR CONTACTOR	52C	1	
24	E02 889 353	COMPRESSOR CAPACITOR	C1	1	55μF/440V AC
25	E02 819 233	BACK PANEL (OUT)		1	
26	E02 817 009	HANDLE		1	
27	E02 726 515	MOTOR SUPPORT		1	
28	E02 127 382	FUSE	F61	1	250V/3.15A
29	E02 336 385	VARISTOR	NR61	1	
30	E02 891 642	CHECK VALVE		1	
31	E02 069 936	CAPILLARY TUBE		1	φ3.0xφ2.0x400
	E02 139 937	CAPILLARY TUBE		1	φ3.0xφ2.0x800

13-7. ACCESSORY

32	E02 817 704	DRAIN SOCKET		1	
33	E02 444 705	DRAIN CAP		2	φ33 2PCS/SET

MUCFH-GA35VB

14-1. OUTDOOR UNIT STRUCTURAL PARTS

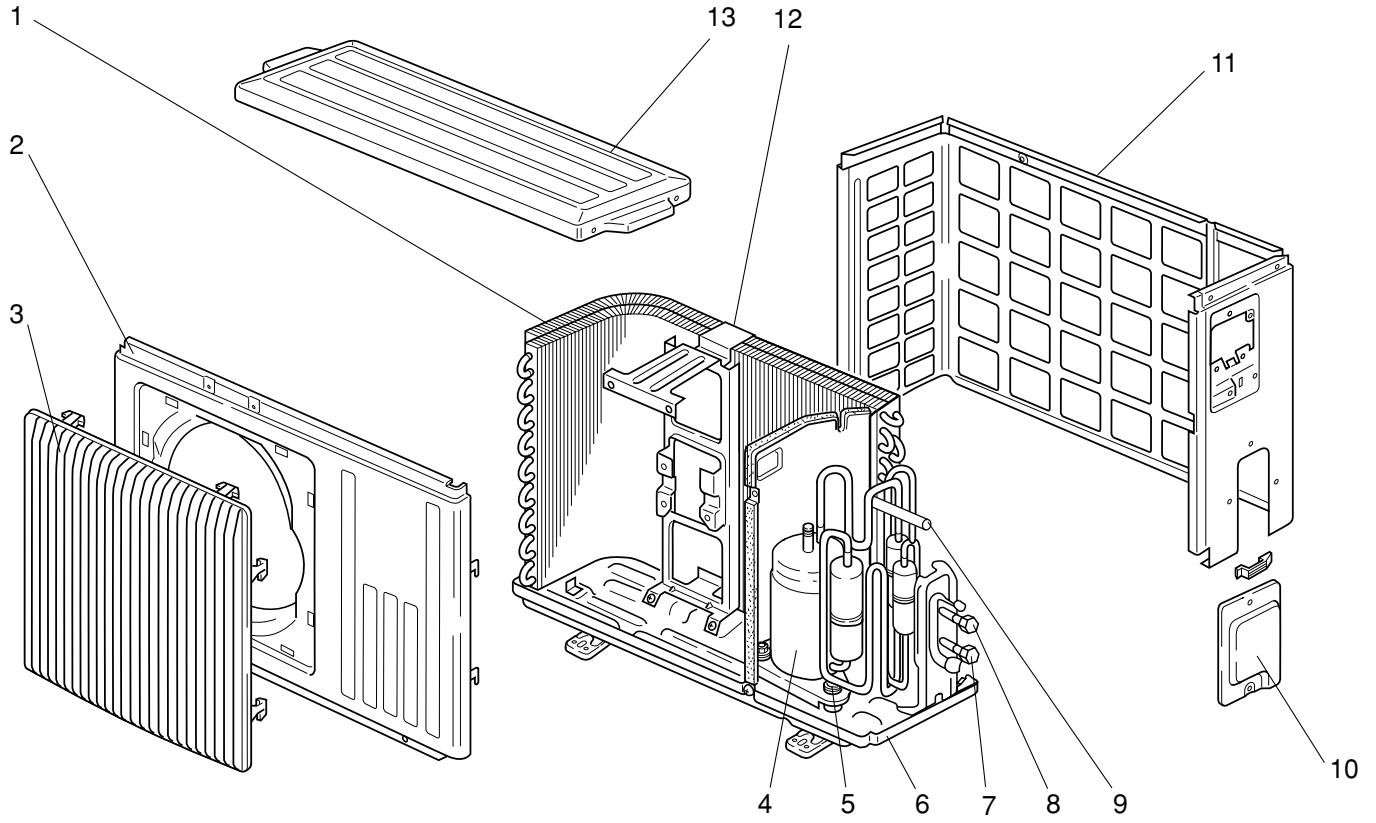

PARTS LIST (non-RoHS compliant)

MUCFH-GA35VB

14-1. OUTDOOR UNIT STRUCTURAL PARTS

Part numbers that are circled are not shown in the illustration.

No.	RoHS	Part No.	Part name	Symbol in Wiring Diagram	Q'ty/unit		Remarks
						MUCFH-GA35VB- E1	
1	G	E12 837 630	OUTDOOR HEAT EXCHANGER			1	
2	G	E12 815 232	CABINET			1	
3	G	E12 815 521	GRILLE(OUT)			1	
4	G	E12 754 900	COMPRESSOR	MC		1	RN135VHSHT
5	G	E12 075 506	COMPRESSOR RUBBER SET			3	3RUBBERS/SET
6	G	E12 832 290	BASE			1	
7	G	E12 910 661	STOP VALVE (GAS)			1	φ12.7
8	G	E12 910 662	STOP VALVE (LIQUID)			1	φ6.35
9	G	E12 931 961	4-WAY VALVE			1	
10	G	E12 815 245	SERVICE PANEL			1	
11	G	E12 836 233	BACK PANEL			1	
12	G	E12 442 515	MOTOR SUPPORT			1	
13	G	E12 815 297	TOP PANEL			1	
⑭	G	E12 156 936	CAPILLARY TUBE			2	φ3.0xφ1.4x500
	G	E12 726 936	CAPILLARY TUBE			1	φ3.0xφ1.6x600
	G	E12 837 936	CAPILLARY TUBE			1	φ3.0xφ1.6x1050
⑮	G	E12 891 642	CHECK VALVE			1	

RoHS PARTS LIST (RoHS compliant)

MUCFH-GA35VB

14-2. OUTDOOR UNIT ELECTRICAL PARTS AND FUNCTIONAL PARTS

14-3. ACCESSORY

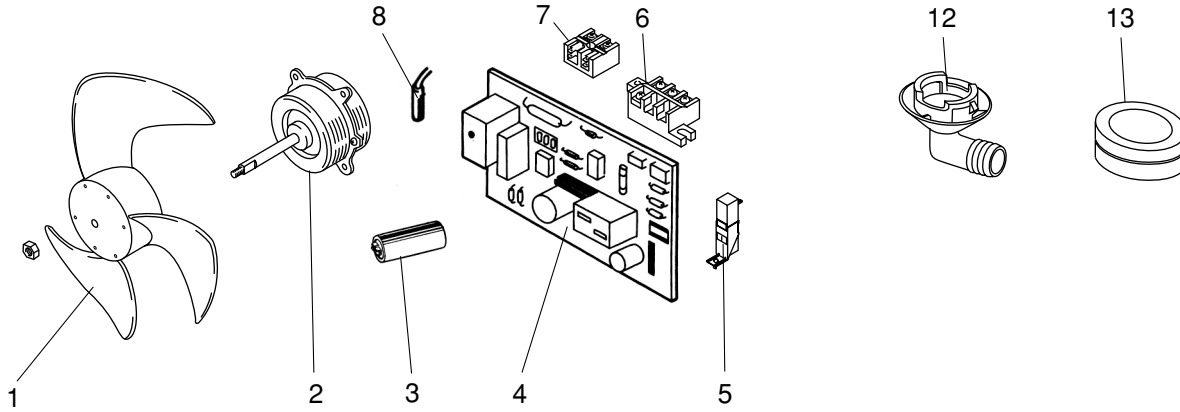

14-2. OUTDOOR UNIT ELECTRICAL PARTS AND FUNCTIONAL PARTS

Part numbers that are circled are not shown in the illustration.

No.	RoHS	Part No.	Part name	Symbol in Wiring Diagram	Q'ty/unit		Remarks
						MUCFH-GA35VB- E1	
1	G	E12 665 501	PROPELLER			1	
2	G	E12 672 301	OUTDOOR FAN MOTOR	MF		1	RA6V33-□□
3	G	E12 900 353	COMPRESSOR CAPACITOR	C1		1	30 μ F /440V AC
4	G	E12 836 451	DEICER P.C. BOARD			1	
5	G	E12 890 383	SURGE ABSORBER	DSAR		1	
6	G	E12 817 374	TERMINAL BLOCK	TB1		1	3P
7	G	E12 836 374	TERMINAL BLOCK	TB2		1	2P
8	G	E12 699 310	DEFROST THERMISTOR	RT61		1	
⑨	G	E12 910 490	R. V. COIL	21S4		1	
⑩	G	E12 095 382	FUSE	F61		1	250V /2A
⑪	G	E12 820 385	VARISTOR	NR61		1	

14-3. ACCESSORY

12	G	E12 817 704	DRAIN SOCKET			1	
13	G	E12 444 705	DRAIN CAP			2	ϕ 33 2PCS/SET

RoHS PARTS LIST (RoHS compliant)

MUCFH-GA50VB

14-4. OUTDOOR UNIT STRUCTURAL PARTS, ELECTRICAL PARTS AND FUNCTIONAL PARTS

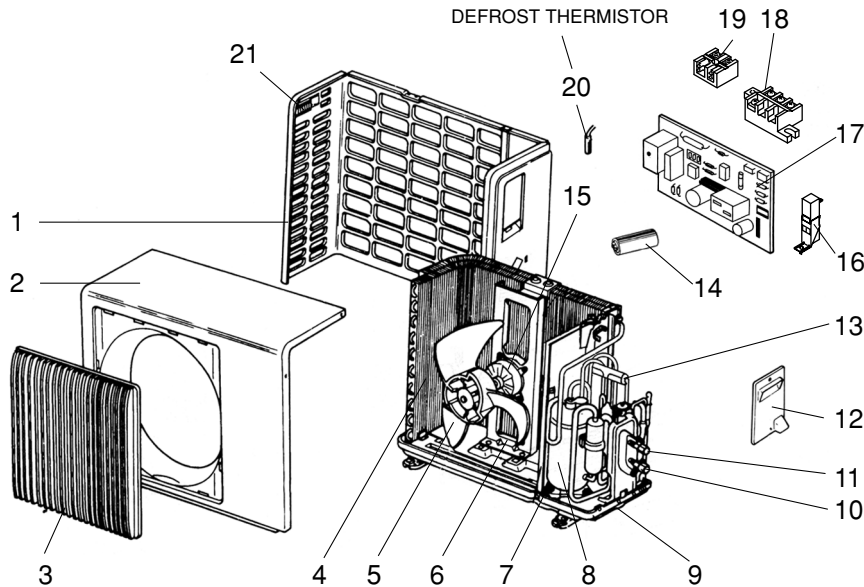

14-5. ACCESSORY

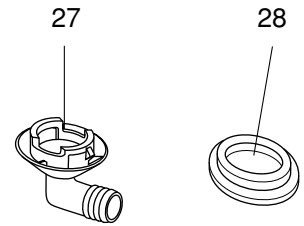

14-4. OUTDOOR UNIT STRUCTURAL PARTS, ELECTRICAL PARTS AND FUNCTIONAL PARTS

Part numbers that are circled are not shown in the illustration.

No.	RoHS	Part No.	Part Name	Symbol in Wiring Diagram	Q'ty/unit		Remarks
					MUCFH-GA50VB- E1		
1	G	E12 817 233	BACK PANEL			1	
2	G	E12 817 232	CABINET			1	
3	G	E12 817 521	GRILLE			1	
4	G	E12 643 630	OUTDOOR HEAT EXCHANGER			1	
5	G	E12 141 501	PROPELLER			1	
6	G	E12 139 515	MOTOR SUPPORT			1	
7	G	E12 075 506	COMPRESSOR RUBBER SET			3	3RUBBERS/SET
8	G	E12 817 900	COMPRESSOR	MC		1	RN196VHSHT
9	G	E12 817 290	BASE			1	
10	G	E12 817 661	STOP VALVE (GAS)			1	φ12.7
11	G	E12 820 662	STOP VALVE (LIQUID)			1	φ 6.35
12	G	E12 817 245	SERVICE PANEL			1	
13	G	E12 891 961	4-WAY VALVE			1	
14	G	E12 888 353	COMPRESSOR CAPACITOR	C1		1	40μF/440V AC
15	G	E12 816 301	OUTDOOR FAN MOTOR	MF		1	RA6V50 - □□
16	G	E12 895 383	SURGE ABSORBER	DSAR		1	
17	G	E12 820 451	DEICER P.C. BOARD			1	
18	G	E12 817 374	TERMINAL BLOCK	TB1		1	3P
19	G	E12 821 374	TERMINAL BLOCK	TB2		1	2P
20	G	E12 820 310	DEFROST THERMISTOR	RT61		1	
21	G	E12 817 009	HANDLE			1	
22	G	E12 139 936	CAPILLARY TUBE			2	φ3.0×φ1.6×750
	G	E12 746 937	CAPILLARY TUBE			1	φ3.0×φ1.6×650
	G	E12 289 937	CAPILLARY TUBE			1	φ3.0×φ1.6×500
	G	E12 820 936	CAPILLARY TUBE			1	φ2.5×φ0.6×1000
23	G	E12 095 382	FUSE	F61		1	250V / 2A
24	G	E12 821 490	R.V. COIL	21S4		1	
25	G	E12 891 642	CHECK VALVE			1	
26	G	E12 820 385	VARIATOR	NR61		1	

14-5. ACCESSORY

27	G	E12 817 704	DRAIN SOCKET			1	
28	G	E12 444 705	DRAIN CAP			2	φ33 2PCS/SET
	G	E12 444 706	DRAIN CAP			1	φ16

RoHS PARTS LIST (RoHS compliant)

MUCFH-GA60VB

14-6. OUTDOOR UNIT STRUCTURAL PARTS, ELECTRICAL PARTS AND FUNCTIONAL PARTS

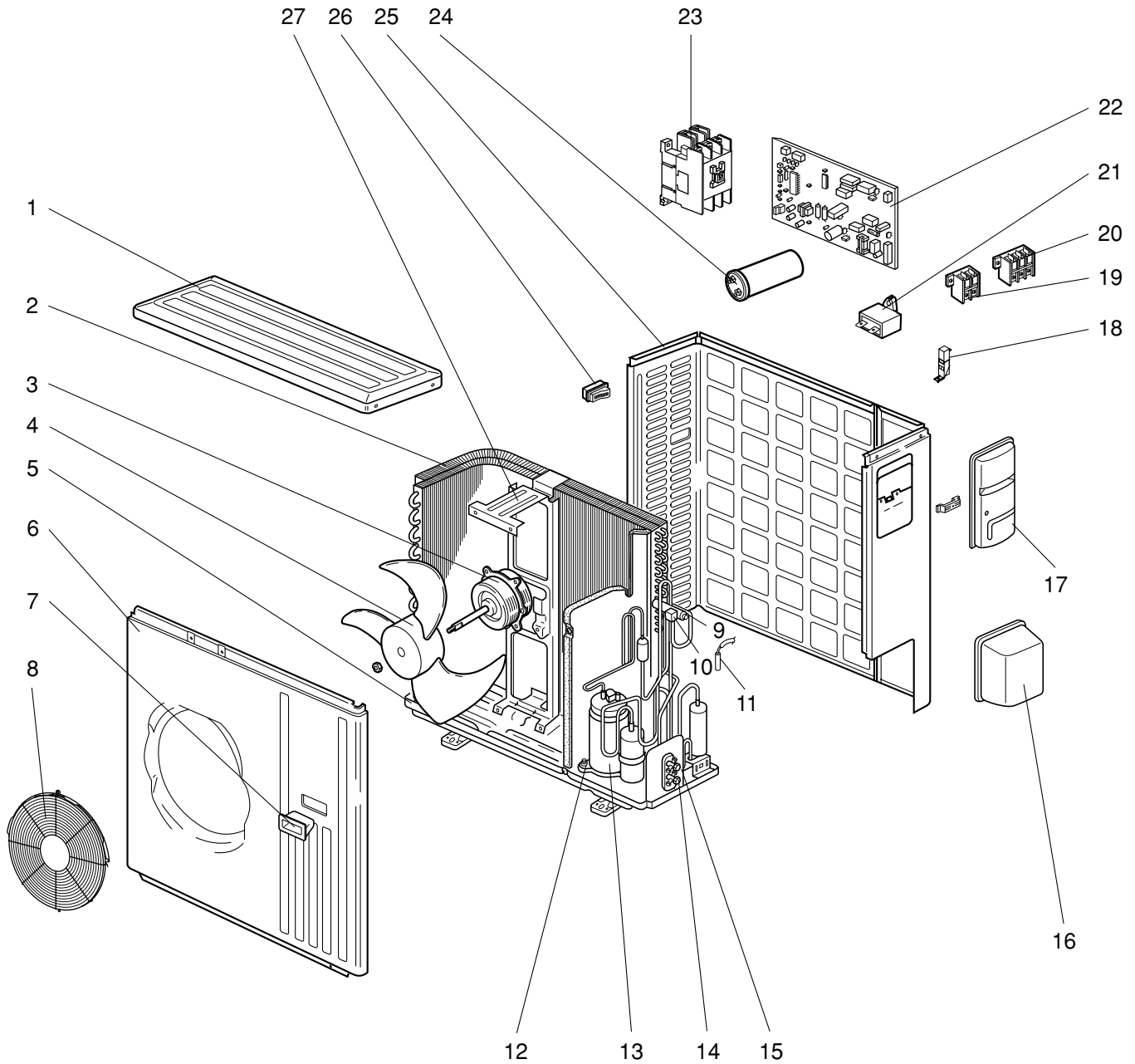

14-7. ACCESSORY

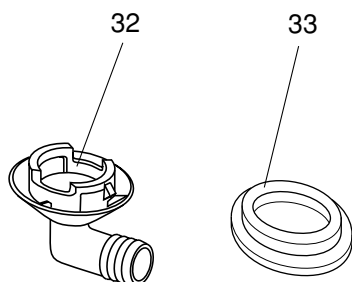

RoHS PARTS LIST (RoHS compliant)

MUCFH-GA60VB

14-6. OUTDOOR UNIT STRUCTURAL PARTS, ELECTRICAL PARTS AND FUNCTIONAL PARTS

Part numbers that are circled are not shown in the illustration.

No.	ROHS	Part No.	Part Name	Symbol in Wiring Diagram	Q'ty/unit	Remarks
					MUCFH-GA60VB - E1	
1	G	E12 819 297	TOP PANEL		1	
2	G	E12 821 630	OUTDOOR HEAT EXCHANGER		1	
3	G	E12 892 301	OUTDOOR FAN MOTOR	MF	1	RA6V85-□□
4	G	E12 214 501	PROPELLER		1	
5	G	E12 821 290	BASE		1	
6	G	E12 819 232	CABINET		1	
7	G	E12 819 009	HANDLE		1	
8	G	E12 D84 521	FAN GUARD		1	Including ice guard
9	G	E12 891 961	4-WAY VALVE		1	
10	G	E12 821 490	R.V. COIL	21S4	1	
11	G	E12 821 310	DEFROST THERMISTOR	RT61	1	
12	G	E12 527 506	COMPRESSOR RUBBER SET		4	4RUBBERS/SET
13	G	E12 821 900	COMPRESSOR	MC	1	NN29VBAHT
14	G	E12 819 661	STOP VALVE (GAS)		1	φ15.88
15	G	E12 821 662	STOP VALVE (LIQUID)		1	φ6.35
16	G	E12 819 650	VALVE COVER		1	
17	G	E12 819 245	SERVICE PANEL		1	
18	G	E12 890 383	SURGE ABSORBER	DSAR	1	
19	G	E12 821 374	TERMINAL BLOCK	TB2	1	2P
20	G	E12 817 374	TERMINAL BLOCK	TB1	1	3P
21	G	E12 895 351	OUTDOOR FAN CAPACITOR	C2	1	3.0μF/440V AC
22	G	E12 912 451	DEICER P.C. BOARD		1	
23	G	E17 012 340	COMPRESSOR CONTACTOR	52C	1	
24	G	E12 889 353	COMPRESSOR CAPACITOR	C1	1	55μF/440V AC
25	G	E12 819 233	BACK PANEL (OUT)		1	
26	G	E12 817 009	HANDLE		1	
27	G	E12 726 515	MOTOR SUPPORT		1	
28	G	E12 A49 382	FUSE	F61	1	T3.15AL250V
29	G	E12 336 385	VARISTOR	NR61	1	
30	G	E12 891 642	CHECK VALVE		1	
31	G	E12 069 936	CAPILLARY TUBE		1	φ3.0xφ2.0x400
	G	E12 139 937	CAPILLARY TUBE		1	φ3.0xφ2.0x800

14-7. ACCESSORY

32	G	E12 817 704	DRAIN SOCKET		1	
33	G	E12 444 705	DRAIN CAP		2	φ33 2PCS/SET



HEAD OFFICE: TOKYO BLDG., 2-7-3, MARUNOUCHI, CHIYODA-KU, TOKYO 100-8310, JAPAN

© Copyright 2005 MITSUBISHI ELECTRIC ENGINEERING CO.,LTD
Distributed in Jun 2010. No.OB381 REVISED EDITION-B 5
Distributed in May 2006. No.OB381 REVISED EDITION-A 6
Distributed in Jan. 2005. No.OB381 6
Made in Japan

New publication, effective Jun. 2010
Specifications subject to change without notice.