

Revision J:

- FAILURE MODE RECALL FUNCTION has been corrected.
- Some descriptions have been modified.

Please void OB377 REVISED EDITION-I.

OUTDOOR UNIT SERVICE MANUAL



**No. OB377
REVISED EDITION-J**

Models

MXZ-2A30VA - E1
MXZ-2A30VA - E2
MXZ-2A40VA - E1
MXZ-2A40VA - E2
MXZ-2A52VA - E1
MXZ-2A52VA - E2
MXZ-3A54VA - E1
MXZ-3A54VA - E2
MXZ-3A54VA - E3
MXZ-3A54VA - E4
MXZ-3A54VA - E5
MXZ-3A54VA - E6
MXZ-3A54VA - E7
MXZ-4A71VA - E1

MXZ-4A71VA - E2
MXZ-4A71VA - E3
MXZ-4A71VA - E4
MXZ-4A71VA - E5
MXZ-4A71VA - E6
MXZ-4A71VA - E7
MXZ-4A80VA - E1
MXZ-4A80VA - E2
MXZ-5A100VA - E1

Indoor unit service manual
MSZ-FA•VA Series (OB371)
MSZ-GA•VA Series (OB378, OB388)
MSZ-CB•VA Series (OB441)
MSZ-GC•VA Series (OBH468)
MSZ-GE•VA Series (OBH515)
MSZ-FD•VA Series (OBH488)

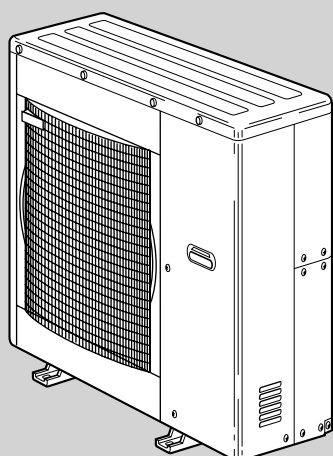

MXZ-4A80VA - E1

CONTENTS

1. TECHNICAL CHANGES	2
2. PART NAMES AND FUNCTIONS	8
3. INDOOR/OUTDOOR CORRESPONDENCE TABLE	10
4. INDOOR UNITS COMBINATION	14
5. SPECIFICATION	61
6. NOISE CRITERIA CURVES	66
7. OUTLINES AND DIMENSIONS	68
8. WIRING DIAGRAM	75
9. REFRIGERANT SYSTEM DIAGRAM	87
10. PERFORMANCE CURVES	97
11. ACTUATOR CONTROL	115
12. SERVICE FUNCTIONS	116
13. TROUBLESHOOTING	120
14. DISASSEMBLY INSTRUCTIONS	147
15. PARTS LIST	162
16. RoHS PARTS LIST	174
17. OPTIONAL PARTS	BACK COVER

NOTE:

- RoHS compliant products have <G> mark on the spec name plate.
- For servicing of RoHS compliant products, refer to the RoHS Parts List.



Use the specified refrigerant only

Never use any refrigerant other than that specified.

Doing so may cause a burst, an explosion, or fire when the unit is being used, serviced, or disposed of.

Correct refrigerant is specified in the manuals and on the spec labels provided with our products.

We will not be held responsible for mechanical failure, system malfunction, unit breakdown or accidents caused by failure to follow the instructions.

Revision A :

- MXZ-3A54VA-[E1] and MXZ-4A71VA-[E2] have been added.
Quick clean kit has been removed. (Refer to 2.)
- MXZ-2A40VA-[E1] and MXZ-2A52VA-[E2] have been added.

Revision B :

- MXZ-2A30VA-[E1] and MXZ-2A40VA-[E2] have been added.
- "Check of HPS" has been corrected.
- RoHS PARTS LIST has been added.

Revision C :

- MXZ-2A52VA-[E2], MXZ-3A54VA-[E3], MXZ-4A71VA-[E3], MXZ-4A80VA-[E2] and MXZ-5A100VA-[E1] have been added.

Revision D:

- MXZ-3A54VA-[E4], and MXZ-4A71VA-[E4] have been added.
- The content of pre-heat control (12-3) has been corrected.
- **5. SPECIFICATION** has been corrected.

Revision E:

- MXZ-2A30VA-[E1] has been added.
- **4. INDOOR UNITS COMBINATION** of MXZ-5A100VA-[E2] has been changed.

Revision F:

- MXZ-3A54VA-[E5] and MXZ-4A71VA-[E5] have been added.

Revision G:

- MXZ-3A54VA-[E6] and MXZ-4A71VA-[E6] have been added.

Revision H:

- Indoor units combinations for 42 class have been added.
- MXZ-3A54VA-[E7] and MXZ-4A71VA-[E7] have been added.

Revision I:

- Errors in TROUBLESHOOTING have been corrected.

Revision J:

- FAILURE MODE RECALL FUNCTION has been corrected.
- Some descriptions have been modified.

1

TECHNICAL CHANGES

MXZ-A26WV -[E1] → MXZ-3A54VA -[E1]

1. Indication of capacity has been changed. (BTU → kW)
2. Capacity specification has been changed. (Cooling capacity 7.1kW → 5.4kW)
3. Dimensions of unit have been changed. (W900 × H900 × D320 → W840 × H710 × D330)
4. Combinations of connectable indoor units have been changed.
5. Capacity class of connectable indoor units has been changed.
6. Communication system has been changed.
7. Power supply way has been changed (change to supply to outdoor unit).
8. Compressor has been changed. (TNB220FMCH → SNB130FLDH1)
9. High-pressure switch has been removed.
10. Outdoor fan motor has been changed. (PM8H60-UA → RC0J60-AA)
11. Evaporation temperature thermistor has been removed.
12. Ambient temperature thermistor has been added.
13. New dip switch has been added to the controller board for "Locking the operation "mode and "Lowering the operating noise "mode.
14. A Quick Clean Kit has been added.

MXZ-A32WV -[E1] → MXZ-4A71VA -[E1]

1. Indication of capacity has been changed. (BTU → kW)
2. Capacity specification has been changed. (Cooling capacity 8.0kW → 7.1kW)
3. Dimensions of unit have been changed. (W900 × H900 × D320 → W840 × H710 × D330)
4. Combinations of connectable indoor units have been changed.
5. Capacity class of connectable indoor units has been changed.
6. Communication system has been changed.
7. Power supply way has been changed (change to supply to outdoor unit).
8. Compressor has been changed. (TNB220FMCH → SNB130FLDH1)
9. High-pressure switch has been removed.
10. Outdoor fan motor has been changed. (PM8H60-UA → RC0J60-AA)
11. Evaporation temperature thermistor has been removed.
12. Ambient temperature thermistor has been added.
13. New dip switch has been added to the controller board for "Locking the operation "mode and "Lowering the operating noise "mode.
14. A Quick Clean Kit has been added.

MXZ-A32WV -[E1] → MXZ-4A80VA -[E1]

1. Indication of capacity has been changed. (BTU → kW)
2. Communication system has been changed.
3. Power supply way has been changed (change to supply to outdoor unit).
4. Evaporation temperature thermistor has been removed.
5. Ambient temperature thermistor has been added.
6. New dip switch has been added to the controller board for "Locking the operation "mode and "Lowering the operating noise "mode.
7. A Quick Clean Kit has been added.

MXZ-A14WV -[E2] → MXZ-2A40VA -[E1]

1. Indication of capacity has been changed. (BTU → kW)
2. Dimensions of unit have been changed. (W840 × H640 × D330 → W800 × H550 × D285)
3. Communication system has been changed.
4. Power supply way has been changed (change to supply to outdoor unit).
5. Compressor has been changed. (SNV092FJYH → SNB130FKCH)
6. Outdoor fan motor has been changed. (RA6V49 → RC0J50-CF)
7. Evaporation temperature thermistor has been removed.
8. Gas pipe temperature thermistor has been removed.
9. Ambient temperature thermistor has been added.

MXZ-A18WV -[E2] → MXZ-2A52VA -[E1]

1. Indication of capacity has been changed. (BTU → kW)
2. Cooling capacity specification has been changed. (5.4 kW → 5.2 kW)
3. Heating capacity specification has been changed. (6.6 kW → 6.4 kW)
4. Dimensions of unit have been changed. (W840 × H640 × D330 → W800 × H550 × D285)
5. Communication system has been changed.
6. Power supply way has been changed (change to supply to outdoor unit).
7. Compressor has been changed. (SNV092FJYH → SNB130FKCH)
8. Outdoor fan motor has been changed. (RA6V49 → RC0J50-CF)
9. Evaporation temperature thermistor has been removed.
10. Gas pipe temperature thermistor has been removed.
11. Ambient temperature thermistor has been added.

MXZ-3A54VA -[E1] → MXZ-3A54VA -[E2]

MXZ-4A71VA -[E1] → MXZ-4A71VA -[E2]

1. Quick clean kit has been removed.

MXZ-2A30VA -[E1]

1. New model

MXZ-2A40VA -[E1] → MXZ-2A40VA -[E2]

1. Compressor has been changed. (SNB130FKCH → KNB092FEDH)
2. Outdoor heat exchanger has been changed.

MXZ-2A52VA -[E1] → MXZ-2A52VA -[E2]

1. Compressor has been changed. (SNB130FKCH → SNB130FKMH)
2. Inverter P.C. board has been changed.

MXZ-3A54VA -[E2] → MXZ-3A54VA -[E3]

1. Compressor has been changed. (SNB130FLDH1 → SNB130FLEH1)
2. Electronic control P.C. board has been changed.

MXZ-4A71VA -[E2] → MXZ-4A71VA -[E3]

1. Compressor has been changed. (SNB130FLDH1 → SNB130FLEH1)
2. Electronic control P.C. board has been changed.

MXZ-4A80VA -[E1] → MXZ-4A80VA -[E2]

1. Ball valve has been changed to stop valve.
2. Gas pipe temperature thermistor has been removed.
3. Pre-heat control has been added.
4. Auto line correcting function has been added.
5. Noise filter P.C. board has been changed.
6. Electronic control P.C. board has been changed.
7. Weight has been changed. (70kg → 67kg)

MXZ-5A100VA -[E1]

1. New model

MXZ-3A54VA -[E3] → MXZ-3A54VA -[E4]

1. Compressor has been changed. (SNB130FLEH1 → SNB130FGBH1)
2. Electronic control P.C. board has been changed.
3. Gas pipe temperature thermistor has been removed.
4. Pre-heat control has been added.
5. Power board has been changed.

MXZ-4A71VA -[E3] → MXZ-4A71VA -[E4]

1. Compressor has been changed. (SNB130FLEH1 → SNB130FGBH1)
2. Electronic control P.C. board has been changed.
3. Gas pipe temperature thermistor has been removed.
4. Pre-heat control has been added.
5. Power board has been changed.

MXZ-2A30VA -[E1] → MXZ-2A30VA -[E2]

1. Compressor has been changed. (KNB092FEDH → KNB073FGDH)
2. Inverter P.C. board has been changed.

MXZ-3A54VA -[E4] → MXZ-3A54VA -[E5]

1. Electronic control P.C. board has been changed.
2. Noise filter P.C. board has been changed.
3. Ball valve has been changed to stop valve.
4. Sub panel has been added.

MXZ-4A71VA -[E4] → MXZ-4A71VA -[E5]

1. Electronic control P.C. board has been changed.
2. Noise filter P.C. board has been changed.
3. Ball valve has been changed to stop valve.
4. Sub panel has been added.

MXZ-3A54VA -[E5] → MXZ-3A54VA -[E6]

MXZ-4A71VA -[E5] → MXZ-4A71VA -[E6]

1. Electronic control P.C. board has been changed.

MXZ-3A54VA -^[E6] → MXZ-3A54VA -^[E7]

MXZ-4A71VA -^[E6] → MXZ-4A71VA -^[E7]

1. Electronic control P.C. board has been changed.
2. Compressor has been changed. (SNB130FGBH1 → SNB130FGBH1T)

INFORMATION FOR THE AIR CONDITIONER WITH R410A REFRIGERANT

- This room air conditioner adopts HFC refrigerant (R410A) which never destroys the ozone layer.
 - Pay particular attention to the following points, though the basic installation procedure is same as that for R22 air conditioners.
- ① As R410A has working pressure approximately 1.6 times as high as that of R22, some special tools and piping parts/materials are required. Refer to the table below.
 - ② Take sufficient care not to allow water and other contaminations to enter the R410A refrigerant during storage and installation, since it is more susceptible to contaminations than R22.
 - ③ For refrigerant piping, use clean, pressure-proof parts/materials specifically designed for R410A. (Refer to 2. Refrigerant piping.)
 - ④ Composition change may occur in R410A since it is a mixed refrigerant. When charging, charge liquid refrigerant to prevent composition change.

		New refrigerant	Previous refrigerant
Refrigerant	Refrigerant	R410A	R22
	Composition (Ratio)	HFC-32: HFC-125 (50%:50%)	R22 (100%)
	Refrigerant handling	Pseudo-azeotropic refrigerant	Single refrigerant
	Chlorine	Not included	Included
	Safety group (ASHRAE)	A1/A1	A1
	Molecular weight	72.6	86.5
	Boiling point (°C)	-51.4	-40.8
	Steam pressure [25°C](Mpa)	1.557	0.94
	Saturated steam density [25°C](Kg/m ³)	64	44.4
	Combustibility	Non combustible	Non combustible
	ODP ※1	0	0.055
	GWP※ 2	1730	1700
	Refrigerant charge method	From liquid phase in cylinder	Gas phase
	Additional charge on leakage	Possible	Possible
Refrigeration oil	Kind	Incompatible oil	Compatible oil
	Color	Non	Light yellow
	Smell	Non	Non

※1 :Ozone Depletion Potential : based on CFC-11

※2 :Global Warming Potential : based on CO₂



	New Specification	Current Specification
Compressor	<p>The incompatible refrigeration oil easily separates from refrigerant and is in the upper layer inside the suction muffler. Raising position of the oil back hole enables to back the refrigeration oil of the upper layer to flow back to the compressor.</p>	<p>Since refrigerant and refrigeration oil are compatible, refrigeration oil goes back to the compressor through the lower position oil back hole.</p>

NOTE : The unit of pressure has been changed to MPa on the international system of units (SI unit system).
 The conversion factor is: **1(MPa [Gauge]) =10.2(kgf/cm² [Gauge])**

Conversion chart of refrigerant temperature and pressure

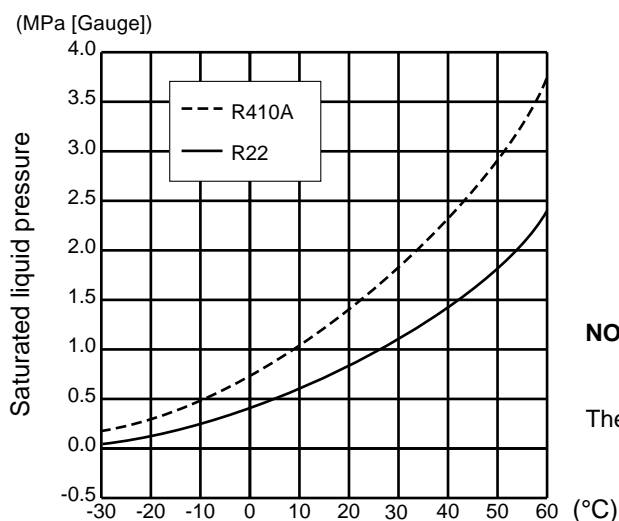

NOTE : The unit of pressure has been changed to MPa on the international system of units (SI unit system).

The conversion factor is: **1(MPa [Gauge]) =10.2(kgf/cm² [Gauge])**

1. Tools dedicated for the air conditioner with R410A refrigerant

The following tools are required for R410A refrigerant. Some R22 tools can be substituted for R410A tools.

The diameter of the service port on the stop valve in outdoor unit has been changed to prevent any other refrigerant from being charged into the unit. Cap size has been changed from 7/16 UNF with 20 threads to 1/2 UNF with 20 threads.

R410A tools	Can R22 tools be used?	Description
Gauge manifold	No	R410A has high pressures beyond the measurement range of existing gauges. Port diameters have been changed to prevent any other refrigerant from being charged into the unit.
Charge hose	No	Hose material and cap size have been changed to improve the pressure resistance.
Gas leak detector	No	Dedicated for HFC refrigerant.
Torque wrench	Yes	6.35 mm and 9.52 mm
	No	12.7 mm and 15.88 mm
Flare tool	Yes	Clamp bar hole has been enlarged to reinforce the spring strength in the tool.
Flare gauge	New	Provided for flaring work (to be used with R22 flare tool).
Vacuum pump adapter	New	Provided to prevent the back flow of oil. This adapter enables you to use vacuum pumps.
Electronic scale for refrigerant charging	New	It is difficult to measure R410A with a charging cylinder because the refrigerant bubbles due to high pressure and high-speed vaporization

No: Not Substitutable for R410A Yes: Substitutable for R410A

2. Refrigerant piping

① Specifications

Use the copper or copper-alloy seamless pipe for refrigerant that meet the following specifications.

Outside diameter	Wall thickness	Insulation material
mm		
6.35	0.8 mm	Heat resisting foam plastic Specific gravity 0.045 Thickness 8 mm
9.52	0.8 mm	
12.7	0.8 mm	
15.88	1.0 mm	

② Flaring work and flare nut

Flaring work for R410A pipe differs from that for R22 pipe.

For details of flaring work, refer to Installation manual "FLARING WORK".

Pipe diameter	Dimension of flare nut	
	R410A	R22
mm		
6.35	17	17
9.52	22	22
12.7	26	24
15.88	29	27

3. Refrigeration oil

Apply the special refrigeration oil (accessories: packed with indoor unit) to the flare and the union seat surfaces.

4. Air purge

- Do not discharge the refrigerant into the atmosphere.
Take care not to discharge refrigerant into the atmosphere during installation, reinstallation, or repairs to the refrigerant circuit.
- Use the vacuum pump for air purging for the purpose of environmental protection.

5. Additional charge

For additional charging, charge the refrigerant from liquid phase of the gas cylinder.

If the refrigerant is charged from the gas phase, composition change may occur in the refrigerant inside the cylinder and the outdoor unit. In this case, ability of the refrigeration cycle decreases or normal operation can be impossible. However, charging the liquid refrigerant all at once may cause the compressor to be locked. Thus, charge the refrigerant slowly.

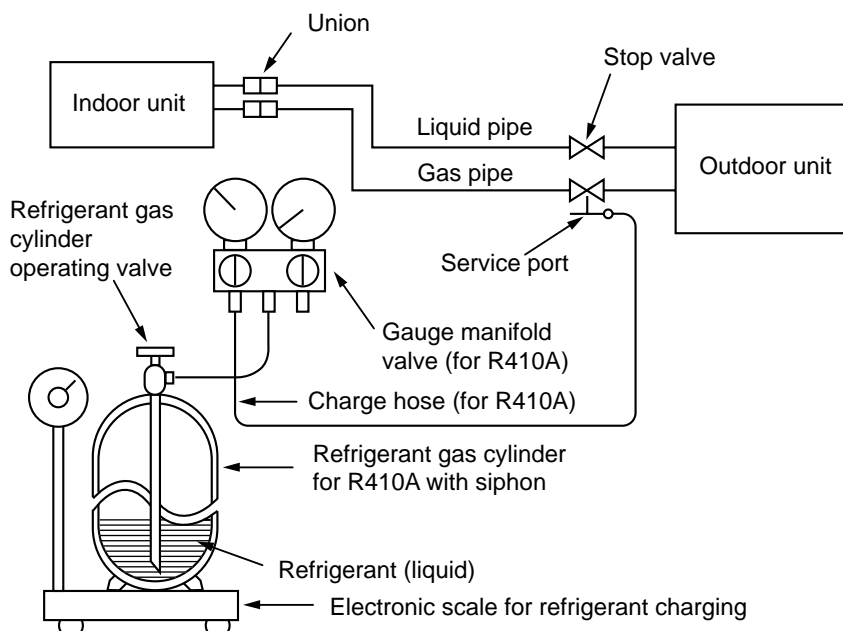

PART NAMES AND FUNCTIONS

MXZ-2A30VA
MXZ-2A40VA
MXZ-2A52VA

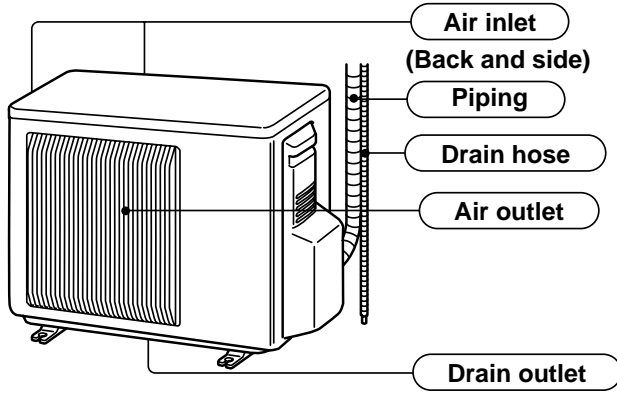

MXZ-3A54VA-E1, E2, E3, E4
MXZ-4A71VA-E1, E2, E3, E4

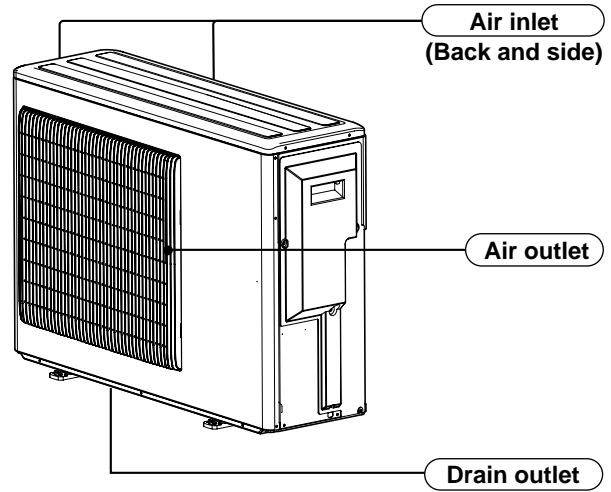

MXZ-3A54VA-E5, E6, E7
MXZ-4A71VA-E5, E6, E7

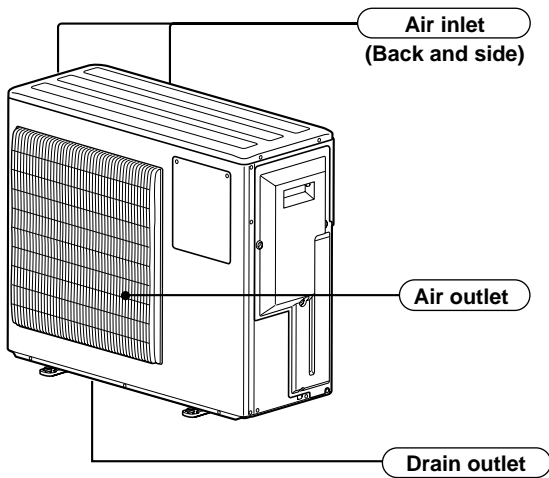

MXZ-4A80VA- E1

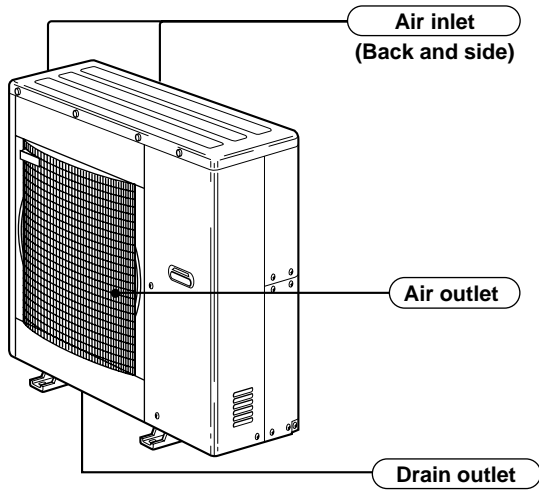

**MXZ-4A80VA- E2
MXZ-5A100VA**

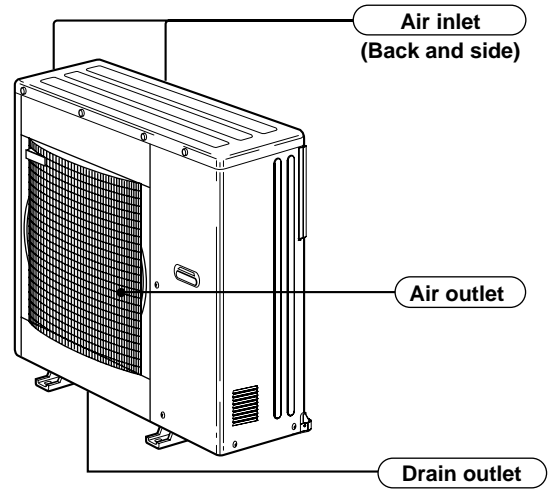

ACCESSORIES

	MXZ-2A30VA MXZ-2A40VA MXZ-2A52VA	MXZ-3A54VA -E1 MXZ-4A71VA -E1	MXZ-3A54VA -E2, E3, E4, E5, E6, E7 MXZ-4A71VA -E2, E3, E4, E5, E6, E7 MXZ-4A80VA MXZ-5A100VA
① Drain socket	1	1	1
② Drain cap	-	2	2
③ Quick Clean kit	-	1	-

3 INDOOR/OUTDOOR CORRESPONDENCE TABLE

* There is no combination other than this table.

	MXZ-2A30VA
Indoor units combination	22+22
	22+25
	25+25

	MXZ-2A40VA
Indoor units combination	22+22
	22+25
	22+35
	25+25
	25+35

	MXZ-2A52VA
Indoor units combination	22+22
	22+25
	22+35
	25+25
	25+35
	35+35

	MXZ-3A54VA
Indoor units combination	22+22
	22+25
	22+35
	22+42
	22+50
	25+25
	25+35
	25+42
	25+50
	35+35
	35+42
	35+50
	42+42
	42+50
	50+50
	22+22+22
	22+22+25
	22+22+35
	22+22+42
	22+22+50
	22+25+25
	22+25+35
	22+25+42
	22+25+50
	22+35+35
	22+35+42
	25+25+25
	25+25+35
	25+25+42
	25+25+50
25+35+35	

	MXZ-4A71VA
Indoor units combination	22+22
	22+25
	22+35
	22+42
	22+50
	22+60
	25+25
	25+35
	25+42
	25+50
	25+60
	35+35
	35+42
	35+50
	35+60
	42+42
	42+50
	42+60
	50+50
	50+60
	60+60
	22+22+22
	22+22+25
	22+22+35
	22+22+42
	22+22+50
	22+22+60
	22+25+25
	22+25+35
	22+25+42
	22+25+50
	22+25+60
	22+35+35
	22+35+42
	22+35+50
	22+35+60
	22+42+42
	22+42+50
	22+42+60
	22+50+50
	25+25+25
	25+25+35
25+25+42	
25+25+50	
25+25+60	
25+35+35	
25+35+42	
25+35+50	
25+35+60	
25+42+42	
25+42+50	
25+50+50	
35+35+35	
35+35+42	

	MXZ-4A71VA
Indoor units combination	35+35+50
	35+42+42
	22+22+22+22
	22+22+22+25
	22+22+22+35
	22+22+22+42
	22+22+22+50
	22+22+25+25
	22+22+25+35
	22+22+25+42
	22+22+25+50
	22+22+35+35
	22+22+35+42
	22+25+25+25
	22+25+25+35
	22+25+25+42
	22+25+25+50
	22+25+35+35
	22+25+35+42
	25+25+25+25
	25+25+25+35
	25+25+25+42
	25+25+25+50
	25+25+35+35

* There is no combination other than this table.

	MXZ-4A80VA
Indoor units combination	22+22
	22+25
	22+35
	22+42
	22+50
	22+60
	22+71
	25+25
	25+35
	25+42
	25+50
	25+60
	25+71
	35+35
	35+42
	35+50
	35+60
	35+71
	42+42
	42+50
	42+60
	42+71
	50+50
	50+60
	50+71
	60+60
	60+71
	22+22+22
	22+22+25
	22+22+35
	22+22+42
	22+22+50
	22+22+60
	22+22+71
	22+25+25
	22+25+35
	22+25+42
	22+25+50
	22+25+60
	22+25+71
	22+35+35
	22+35+42
	22+35+50
	22+35+60
	22+35+71
	22+42+42
	22+42+50
	22+42+60
	22+42+71
	22+50+50
22+50+60	
22+50+71	
25+25+25	
25+25+35	

	MXZ-4A80VA
Indoor units combination	25+25+42
	25+25+50
	25+25+60
	25+25+71
	25+35+35
	25+35+42
	25+35+50
	25+35+60
	25+35+71
	25+42+42
	25+42+50
	25+42+60
	25+42+71
	25+50+50
	25+50+60
	35+35+35
	35+35+42
	35+35+50
	35+35+60
	35+35+71
	35+42+42
	35+42+50
	35+42+60
	35+50+50
	35+50+60
	22+22+22+22
	22+22+22+25
	22+22+22+35
	22+22+22+42
	22+22+22+50
	22+22+22+60
	22+22+22+71
	22+22+25+25
	22+22+25+35
	22+22+25+42
	22+22+25+50
	22+22+25+60
	22+22+25+71
	22+22+35+35
	22+22+35+42
	22+22+35+50
	22+22+35+60
	22+22+42+42
	22+22+42+50
	22+22+50+50
	22+25+25+25
	22+25+25+35
	22+25+25+42
	22+25+25+50
	22+25+25+60
22+25+35+35	
22+25+35+42	
22+25+35+50	
22+25+35+60	

	MXZ-4A80VA
Indoor units combination	22+35+35+35
	22+35+35+42
	22+35+35+50
	22+35+42+42
	25+25+25+25
	25+25+25+35
	25+25+25+42
	25+25+25+50
	25+25+25+60
	25+25+35+35
	25+25+35+42
	25+25+35+50
	25+35+35+35
	25+35+35+42
	35+35+35+35

*There is no combination other than this table.

	MXZ-5A100VA
Indoor units combination	22+22
	22+25
	22+35
	22+42
	22+50
	22+60
	22+71
	25+25
	25+35
	25+42
	25+50
	25+60
	25+71
	35+35
	35+42
	35+50
	35+60
	35+71
	42+42
	42+50
	42+60
	42+71
	50+50
	50+60
	50+71
	60+60
	60+71
	71+71
	22+22+22
	22+22+25
	22+22+35
	22+22+42
	22+22+50
	22+22+60
	22+22+71
	22+25+25
	22+25+35
	22+25+42
	22+25+50
	22+25+60
	22+25+71
	22+35+35
22+35+42	
22+35+50	
22+35+60	
22+35+71	
22+42+42	
22+42+50	
22+42+60	
22+42+71	
22+50+50	
22+50+60	
22+50+71	

	MXZ-5A100VA
Indoor units combination	22+60+60
	22+60+71
	25+25+25
	25+25+35
	25+25+42
	25+25+50
	25+25+60
	25+25+71
	25+35+35
	25+35+42
	25+35+50
	25+35+60
	25+35+71
	25+42+42
	25+42+50
	25+42+60
	25+42+71
	25+50+50
	25+50+60
	25+50+71
	25+60+60
	25+60+71
	35+35+35
	35+35+42
	35+35+50
	35+35+60
	35+35+71
	35+42+42
	35+42+50
	35+42+60
	35+42+71
	35+50+50
	35+50+60
	35+50+71
	35+60+60
	35+60+71
	42+42+42
	42+42+50
	42+42+60
	42+42+71
	42+50+50
	42+50+60
42+50+71	
42+60+60	
50+50+50	
50+50+60	
50+50+71	
22+22+22+22	
22+22+22+25	
22+22+22+35	
22+22+22+42	
22+22+22+50	
22+22+22+60	

	MXZ-5A100VA
Indoor units combination	22+22+22+71
	22+22+25+25
	22+22+25+35
	22+22+25+42
	22+22+25+50
	22+22+25+60
	22+22+25+71
	22+22+35+35
	22+22+35+42
	22+22+35+50
	22+22+35+60
	22+22+35+71
	22+22+42+42
	22+22+42+50
	22+22+42+60
	22+22+42+71
	22+22+50+50
	22+22+50+60
	22+22+50+71
	22+25+25+25
	22+25+25+35
	22+25+25+42
	22+25+25+50
	22+25+25+60
	22+25+25+71
	22+25+35+35
	22+25+35+42
	22+25+35+50
	22+25+35+60
	22+25+35+71
	22+25+42+42
	22+25+42+50
	22+25+42+60
	22+25+42+71
	22+25+50+50
	22+25+50+60
	22+25+50+71
	22+35+35+35
	22+35+35+42
	22+35+35+50
	22+35+35+60
	22+35+35+71
22+35+42+42	
22+35+42+50	
22+35+42+60	
22+35+42+71	
22+35+50+50	
22+35+50+60	
22+35+50+71	
22+42+42+42	
22+42+42+50	
22+42+42+60	
22+42+42+71	
22+42+50+50	
22+42+50+60	
22+42+50+71	
25+25+25+25	

	MXZ-5A100VA
Indoor units combination	25+25+25+35
	25+25+25+42
	25+25+25+50
	25+25+25+60
	25+25+25+71
	25+25+35+35
	25+25+35+42
	25+25+35+50
	25+25+35+60
	25+25+35+71
	25+25+42+42
	25+25+42+50
	25+25+42+60
	25+25+42+71
	25+25+50+50
	25+25+50+60
	25+25+50+71
	25+35+35+35
	25+35+35+42
	25+35+35+50
	25+35+35+60
	25+35+35+71
	25+35+42+42
	25+35+42+50
	25+35+42+60
	25+35+42+71
	25+42+42+42
	25+42+42+50
	25+42+42+60
	25+42+50+50
	35+35+35+35
	35+35+35+42
	35+35+35+50
	35+35+35+60
	35+35+42+42
	35+35+42+50
	35+35+42+60
	35+35+42+71
	22+22+22+22+22
	22+22+22+22+25
	22+22+22+22+35
	22+22+22+22+42
22+22+22+22+50	
22+22+22+22+60	
22+22+22+22+71	
22+22+22+25+25	
22+22+22+25+35	
22+22+22+25+42	
22+22+22+25+50	
22+22+22+25+60	
22+22+22+25+71	
22+22+22+35+35	
22+22+22+35+42	



*There is no combination other than this table.

Indoor units combination	MXZ-5A100VA	Indoor units combination	MXZ-5A100VA
	22+22+22+35+50		25+25+25+42+42
	22+22+22+35+60		25+25+25+42+50
	22+22+22+35+71		25+25+35+35+35
	22+22+22+42+42		25+25+35+35+42
	22+22+22+42+50		25+25+35+35+50
	22+22+22+42+60		25+25+35+42+42
	22+22+25+25+25		
	22+22+25+25+35		
	22+22+25+25+42		
	22+22+25+25+50		
	22+22+25+25+60		
	22+22+25+25+71		
	22+22+25+35+35		
	22+22+25+35+42		
	22+22+25+35+50		
	22+22+25+35+60		
	22+22+25+42+42		
	22+22+25+42+50		
	22+22+25+42+60		
	22+22+35+35+35		
	22+22+35+35+42		
	22+22+35+35+50		
	22+22+35+42+42		
	22+22+35+42+50		
	22+22+42+42+42		
	22+25+25+25+25		
	22+25+25+25+35		
	22+25+25+25+42		
	22+25+25+25+50		
	22+25+25+25+60		
	22+25+25+25+71		
	22+25+25+35+35		
	22+25+25+35+42		
	22+25+25+35+50		
	22+25+25+35+60		
	22+25+25+42+42		
	22+25+25+42+50		
	22+25+35+35+35		
	22+25+35+35+42		
	22+25+35+35+50		
	22+25+35+42+42		
	22+35+35+35+35		
	22+35+35+35+42		
	25+25+25+25+25		
	25+25+25+25+35		
	25+25+25+25+42		
	25+25+25+25+50		
	25+25+25+25+60		
	25+25+25+25+71		
25+25+25+35+35			
25+25+25+35+42			
25+25+25+35+50			
25+25+25+35+60			

MXZ-2A30VA

NOTE: Electrical data is for outdoor unit only.

Indoor units combination	Cooling capacity (kW)			Outdoor unit power consumption (kW)	Current (A)	Power factor (%)
	Unit A	Unit B	Total			
22	2.20	–	2.2 (0.9 - 3.0)	0.430 (0.120 - 0.620)	2.08	90
25	2.50	–	2.5 (0.9 - 3.3)	0.490 (0.120 - 0.690)	2.37	90
22+22	1.40	1.40	2.8 (1.1 - 3.8)	0.540 (0.250 - 0.970)	2.61	90
22+25	1.40	1.50	2.9 (1.1 - 3.9)	0.565 (0.250 - 1.020)	2.73	90
25+25	1.50	1.50	3.0 (1.1 - 4.0)	0.595 (0.250 - 1.070)	2.87	90

NOTE: Electrical data is for outdoor unit only.

Indoor units combination	Heating capacity (kW)			Outdoor unit power consumption (kW)	Current (A)	Power factor (%)
	Unit A	Unit B	Total			
22	3.30	–	3.3 (0.9 - 4.0)	0.670 (0.110 - 0.910)	3.24	90
25	3.60	–	3.6 (0.9 - 4.5)	0.730 (0.110 - 1.050)	3.53	90
22+22	1.90	1.90	3.8 (1.0 - 4.3)	0.705 (0.200 - 0.770)	3.41	90
22+25	1.90	2.00	3.9 (1.0 - 4.4)	0.725 (0.200 - 0.795)	3.50	90
25+25	2.00	2.00	4.0 (1.0 - 4.5)	0.745 (0.200 - 0.810)	3.60	90

MXZ-2A40VA

NOTE: Electrical data is for outdoor unit only.

Indoor units combination	Cooling capacity (kW)			Outdoor unit power consumption (kW)	Current (A)	Power factor (%)
	Unit A	Unit B	Total			
22	2.20	–	2.2 (0.9 - 3.0)	0.430 (0.120 - 0.620)	2.08	90
25	2.50	–	2.5 (0.9 - 3.3)	0.490 (0.120 - 0.690)	2.37	90
35	3.50	–	3.5 (0.9 - 4.0)	0.730 (0.120 - 0.900)	3.53	90
22+22	1.90	1.90	3.8 (1.1 - 4.3)	0.830 (0.250 - 1.110)	3.80	95
22+25	1.83	2.07	3.9 (1.1 - 4.3)	0.970 (0.250 - 1.110)	4.44	95
22+35	1.51	2.39	3.9 (1.1 - 4.4)	0.970 (0.250 - 1.130)	4.44	95
25+25	1.95	1.95	3.9 (1.1 - 4.4)	0.970 (0.250 - 1.130)	4.44	95
25+35	1.67	2.33	4.0 (1.1 - 4.5)	1.045 (0.250 - 1.170)	4.78	95

NOTE: Electrical data is for outdoor unit only.

Indoor units combination	Heating capacity (kW)			Outdoor unit power consumption (kW)	Current (A)	Power factor (%)
	Unit A	Unit B	Total			
22	3.30	–	3.3 (0.9 - 4.0)	0.670 (0.110 - 0.910)	3.24	90
25	3.60	–	3.6 (0.9 - 4.5)	0.730 (0.110 - 1.050)	3.53	90
35	4.00	–	4.0 (0.9 - 4.8)	0.870 (0.110 - 1.150)	4.20	90
22+22	2.20	2.20	4.4 (1.0 - 4.8)	0.910 (0.200 - 1.010)	4.16	95
22+25	2.06	2.34	4.4 (1.0 - 4.8)	0.910 (0.200 - 1.010)	4.16	95
22+35	1.70	2.70	4.4 (1.0 - 4.9)	0.910 (0.200 - 1.030)	4.16	95
25+25	2.20	2.20	4.4 (1.0 - 4.9)	0.910 (0.200 - 1.030)	4.16	95
25+35	1.85	2.65	4.5 (1.0 - 5.0)	0.945 (0.200 - 1.050)	4.32	95

MXZ-2A52VA**NOTE:** Electrical data is for outdoor unit only.

Indoor units combination	Cooling capacity (kW)			Outdoor unit power consumption (kW)	Current (A)	Power factor (%)
	Unit A	Unit B	Total			
22	2.20	–	2.2 (0.9 - 3.0)	0.430 (0.120 - 0.620)	2.08	90
25	2.50	–	2.5 (0.9 - 3.3)	0.490 (0.120 - 0.690)	2.37	90
35	3.50	–	3.5 (0.9 - 4.0)	0.730 (0.120 - 0.900)	3.53	90
22+22	2.20	2.20	4.4 (1.1 - 5.3)	1.130 (0.250 - 1.510)	5.12	96
22+25	2.20	2.50	4.7 (1.1 - 5.4)	1.250 (0.250 - 1.560)	5.66	96
22+35	1.93	3.07	5.0 (1.1 - 5.6)	1.400 (0.250 - 1.650)	6.28	97
25+25	2.50	2.50	5.0 (1.1 - 5.6)	1.400 (0.250 - 1.650)	6.28	97
25+35	2.13	2.97	5.1 (1.1 - 5.8)	1.450 (0.250 - 1.740)	6.50	97
35+35	2.60	2.60	5.2 (1.1 - 6.0)	1.505 (0.250 - 1.830)	6.75	97

NOTE: Electrical data is for outdoor unit only.

Indoor units combination	Heating capacity (kW)			Outdoor unit power consumption (kW)	Current (A)	Power factor (%)
	Unit A	Unit B	Total			
22	3.30	–	3.3 (0.9 - 4.0)	0.670 (0.110 - 0.910)	3.24	90
25	3.60	–	3.6 (0.9 - 4.5)	0.730 (0.110 - 1.050)	3.53	90
35	4.00	–	4.0 (0.9 - 4.8)	0.870 (0.110 - 1.150)	4.20	90
22+22	3.05	3.05	6.1 (1.0 - 6.7)	1.550 (0.200 - 1.730)	6.95	97
22+25	2.90	3.30	6.2 (1.0 - 6.8)	1.600 (0.200 - 1.750)	7.17	97
22+35	2.43	3.87	6.3 (1.0 - 7.0)	1.650 (0.200 - 1.790)	7.40	97
25+25	3.15	3.15	6.3 (1.0 - 7.0)	1.650 (0.200 - 1.790)	7.40	97
25+35	2.63	3.67	6.3 (1.0 - 7.1)	1.650 (0.200 - 1.820)	7.40	97
35+35	3.20	3.20	6.4 (1.0 - 7.2)	1.705 (0.200 - 1.840)	7.64	97

MXZ-3A54VA

NOTE: Electrical data is for outdoor unit only.

Indoor units combination	Cooling capacity (kW)				Outdoor unit power consumption (kW)	Current (A)	Power factor (%)
	Unit A	Unit B	Unit C	Total			
22	2.2	-	-	2.2 (1.4 - 3.0)	0.590 (0.420 - 0.740)	2.59	99
25	2.5	-	-	2.5 (1.4 - 3.3)	0.660 (0.420 - 0.830)	2.90	99
35	3.5	-	-	3.5 (1.5 - 4.3)	0.950 (0.430 - 1.180)	4.17	99
42	4.2	-	-	4.2 (1.6 - 5.0)	1.220 (0.450 - 1.420)	5.36	99
50	5.0	-	-	5.0 (1.6 - 5.6)	1.500 (0.480 - 1.660)	6.59	99
22+22	2.2	2.2	-	4.4 (2.0 - 5.4)	1.180 (0.540 - 1.450)	5.18	99
22+25	2.2	2.5	-	4.7 (2.0 - 5.8)	1.300 (0.540 - 1.630)	5.71	99
22+35	2.08	3.32	-	5.4 (2.0 - 6.8)	1.600 (0.540 - 2.550)	7.03	99
22+42	1.86	3.54	-	5.4 (2.0 - 6.8)	1.590 (0.540 - 2.490)	6.98	99
22+50	1.65	3.75	-	5.4 (2.0 - 6.8)	1.580 (0.550 - 2.440)	6.94	99
25+25	2.5	2.5	-	5.0 (2.0 - 6.0)	1.420 (0.540 - 1.750)	6.24	99
25+35	2.25	3.15	-	5.4 (2.0 - 6.8)	1.600 (0.540 - 2.550)	7.03	99
25+42	2.01	3.39	-	5.4 (2.0 - 6.8)	1.590 (0.540 - 2.490)	6.98	99
25+50	1.8	3.6	-	5.4 (2.0 - 6.8)	1.580 (0.550 - 2.440)	6.94	99
35+35	2.7	2.7	-	5.4 (2.0 - 6.8)	1.600 (0.540 - 2.550)	7.03	99
35+42	2.4	3.0	-	5.4 (2.0 - 6.8)	1.560 (0.540 - 2.490)	6.85	99
35+50	2.22	3.18	-	5.4 (2.0 - 6.8)	1.530 (0.550 - 2.440)	6.72	99
42+42	2.7	2.7	-	5.4 (2.0 - 6.8)	1.530 (0.550 - 2.440)	6.72	99
42+50	2.47	2.93	-	5.4 (2.1 - 6.8)	1.540 (0.550 - 2.390)	6.76	99
50+50	2.7	2.7	-	5.4 (2.1 - 6.8)	1.550 (0.560 - 2.340)	6.81	99
22+22+22	1.8	1.8	1.8	5.4 (2.9 - 6.8)	1.295 (0.670 - 1.770)	5.69	99
22+22+25	1.72	1.72	1.96	5.4 (2.9 - 6.8)	1.295 (0.670 - 1.770)	5.69	99
22+22+35	1.5	1.5	2.4	5.4 (2.9 - 6.8)	1.295 (0.670 - 1.770)	5.69	99
22+22+42	1.38	1.38	2.64	5.4 (2.9 - 6.8)	1.280 (0.670 - 1.780)	5.62	99
22+22+50	1.26	1.26	2.88	5.4 (2.9 - 6.8)	1.265 (0.680 - 1.790)	5.56	99
22+25+25	1.64	1.88	1.88	5.4 (2.9 - 6.8)	1.295 (0.670 - 1.770)	5.69	99

MXZ-3A54VA**NOTE:** Electrical data is for outdoor unit only.

Indoor units combination	Cooling capacity (kW)				Outdoor unit power consumption (kW)	Current (A)	Power factor (%)
	Unit A	Unit B	Unit C	Total			
22+25+35	1.45	1.65	2.3	5.4 (2.9 - 6.8)	1.295 (0.670 - 1.770)	5.69	99
22+25+42	1.33	1.52	2.55	5.4 (2.9 - 6.8)	1.280 (0.670 - 1.780)	5.62	99
22+25+50	1.23	1.39	2.78	5.4 (2.9 - 6.8)	1.265 (0.680 - 1.790)	5.56	99
22+35+35	1.3	2.05	2.05	5.4 (2.9 - 6.8)	1.295 (0.670 - 1.770)	5.69	99
22+35+42	1.2	1.91	2.29	5.4 (2.9 - 6.8)	1.290 (0.670 - 1.770)	5.67	99
25+25+25	1.8	1.8	1.8	5.4 (2.9 - 6.8)	1.295 (0.670 - 1.770)	5.69	99
25+25+35	1.59	1.59	2.22	5.4 (2.9 - 6.8)	1.295 (0.670 - 1.770)	5.69	99
25+25+42	1.47	1.47	2.46	5.4 (2.9 - 6.8)	1.280 (0.670 - 1.780)	5.62	99
25+25+50	1.35	1.35	2.7	5.4 (2.9 - 6.8)	1.265 (0.680 - 1.790)	5.56	99
25+35+35	1.42	1.99	1.99	5.4 (2.9 - 6.8)	1.295 (0.670 - 1.770)	5.69	99

MXZ-3A54VA

NOTE: Electrical data is for outdoor unit only.

Indoor units combination	Heating capacity (kW)				Outdoor unit power consumption (kW)	Current (A)	Power factor (%)
	Unit A	Unit B	Unit C	Total			
22	3.3	-	-	3.3 (1.2 - 4.2)	0.820 (0.380 - 1.090)	3.60	99
25	3.6	-	-	3.6 (1.2 - 4.5)	0.910 (0.380 - 1.190)	4.00	99
35	4.0	-	-	4.0 (1.2 - 4.8)	1.040 (0.380 - 1.300)	4.57	99
42	5.4	-	-	5.4 (1.3 - 6.5)	1.400 (0.370 - 1.800)	6.15	99
50	6.8	-	-	6.8 (1.4 - 8.2)	1.770 (0.370 - 2.300)	7.77	99
22+22	3.3	3.3	-	6.6 (1.8 - 7.2)	1.500 (0.410 - 1.710)	6.59	99
22+25	3.18	3.62	-	6.8 (1.8 - 8.7)	1.580 (0.410 - 2.350)	6.94	99
22+35	2.62	4.18	-	6.8 (1.8 - 9.0)	1.580 (0.410 - 2.390)	6.94	99
22+42	2.34	4.46	-	6.8 (1.8 - 9.0)	1.510 (0.400 - 2.300)	6.63	99
22+50	2.08	4.72	-	6.8 (1.8 - 9.0)	1.440 (0.390 - 2.220)	6.32	99
25+25	3.4	3.4	-	6.8 (1.8 - 9.0)	1.580 (0.410 - 2.390)	6.94	99
25+35	2.83	3.97	-	6.8 (1.8 - 9.0)	1.580 (0.410 - 2.390)	6.94	99
25+42	2.54	4.26	-	6.8 (1.8 - 9.0)	1.510 (0.400 - 2.300)	6.63	99
25+50	2.27	4.53	-	6.8 (1.8 - 9.0)	1.440 (0.390 - 2.220)	6.32	99
35+35	3.4	3.4	-	6.8 (1.8 - 9.0)	1.580 (0.410 - 2.390)	6.94	99
35+42	3.09	3.71	-	6.8 (1.8 - 9.0)	1.510 (0.410 - 2.300)	6.63	99
35+50	2.8	4.0	-	6.8 (1.8 - 9.0)	1.440 (0.410 - 2.220)	6.32	99
42+42	3.4	3.4	-	6.8 (1.8 - 9.0)	1.440 (0.410 - 2.220)	6.32	99
42+50	3.1	3.7	-	6.8 (1.9 - 9.0)	1.410 (0.380 - 2.130)	6.19	99
50+50	3.4	3.4	-	6.8 (1.9 - 9.0)	1.390 (0.360 - 2.040)	6.10	99
22+22+22	2.27	2.27	2.27	6.8 (2.6 - 9.0)	1.455 (0.500 - 2.120)	6.39	99
22+22+25	2.17	2.17	2.46	6.8 (2.6 - 9.0)	1.455 (0.500 - 2.120)	6.39	99
22+22+35	1.89	1.89	3.02	6.8 (2.6 - 9.0)	1.455 (0.500 - 2.120)	6.39	99
22+22+42	1.74	1.74	3.32	6.8 (2.6 - 9.0)	1.380 (0.490 - 2.040)	6.06	99
22+22+50	1.59	1.59	3.62	6.8 (2.6 - 9.0)	1.310 (0.480 - 1.960)	5.75	99
22+25+25	2.08	2.36	2.36	6.8 (2.6 - 9.0)	1.455 (0.500 - 2.120)	6.39	99

MXZ-3A54VA**NOTE:** Electrical data is for outdoor unit only.

Indoor units combination	Heating capacity (kW)				Outdoor unit power consumption (kW)	Current (A)	Power factor (%)
	Unit A	Unit B	Unit C	Total			
22+25+35	1.83	2.07	2.9	6.8 (2.6 - 9.0)	1.455 (0.500 - 2.120)	6.39	99
22+25+42	1.68	1.91	3.21	6.8 (2.6 - 9.0)	1.380 (0.490 - 2.040)	6.06	99
22+25+50	1.54	1.75	3.51	6.8 (2.6 - 9.0)	1.310 (0.480 - 1.960)	5.75	99
22+35+35	1.62	2.59	2.59	6.8 (2.6 - 9.0)	1.455 (0.500 - 2.120)	6.39	99
22+35+42	1.51	2.41	2.88	6.8 (2.6 - 9.0)	1.455 (0.500 - 2.120)	6.39	99
25+25+25	2.27	2.27	2.27	6.8 (2.6 - 9.0)	1.455 (0.500 - 2.120)	6.39	99
25+25+35	2.0	2.0	2.8	6.8 (2.6 - 9.0)	1.455 (0.500 - 2.120)	6.39	99
25+25+42	1.85	1.85	3.1	6.8 (2.6 - 9.0)	1.380 (0.490 - 2.040)	6.06	99
25+25+50	1.7	1.7	3.4	6.8 (2.6 - 9.0)	1.310 (0.480 - 1.960)	5.75	99
25+35+35	1.78	2.51	2.51	6.8 (2.6 - 9.0)	1.455 (0.460 - 2.120)	6.39	99

MXZ-4A71VA
NOTE: Electrical data is for outdoor unit only.

Indoor units combination	Cooling capacity (kW)					Outdoor unit power consumption (kW)	Current (A)	Power factor (%)
	Unit A	Unit B	Unit C	Unit D	Total			
22	2.2	-	-	-	2.2 (1.4 - 3.0)	0.590 (0.420 - 0.740)	2.59	99
25	2.5	-	-	-	2.5 (1.4 - 3.3)	0.660 (0.420 - 0.830)	2.90	99
35	3.5	-	-	-	3.5 (1.5 - 4.3)	0.950 (0.430 - 1.180)	4.17	99
42	4.2	-	-	-	4.2 (1.6 - 5.0)	1.220 (0.450 - 1.420)	5.36	99
50	5.0	-	-	-	5.0 (1.6 - 5.6)	1.500 (0.480 - 1.660)	6.59	99
60	6.0	-	-	-	6.0 (1.6 - 6.6)	2.110 (0.480 - 2.290)	9.27	99
22+22	2.2	2.2	-	-	4.4 (2.0 - 5.4)	1.180 (0.540 - 1.450)	5.18	99
22+25	2.2	2.5	-	-	4.7 (2.0 - 5.8)	1.300 (0.540 - 1.630)	5.71	99
22+35	2.2	3.5	-	-	5.7 (2.0 - 6.6)	1.800 (0.540 - 2.100)	7.91	99
22+42	2.2	4.2	-	-	6.4 (2.0 - 7.1)	2.120 (0.540 - 2.540)	9.31	99
22+50	2.08	4.72	-	-	6.8 (2.0 - 7.1)	2.440 (0.550 - 2.570)	10.72	99
22+60	1.82	4.98	-	-	6.8 (2.0 - 7.1)	2.460 (0.550 - 2.600)	10.80	99
25+25	2.5	2.5	-	-	5.0 (2.0 - 6.0)	1.420 (0.540 - 1.750)	6.24	99
25+35	2.5	3.5	-	-	6.0 (2.0 - 7.1)	2.010 (0.540 - 2.540)	8.83	99
25+42	2.5	4.2	-	-	6.7 (2.0 - 7.1)	2.220 (0.540 - 2.560)	9.75	99
25+50	2.27	4.53	-	-	6.8 (2.0 - 7.1)	2.440 (0.550 - 2.590)	10.72	99
25+60	2.0	4.8	-	-	6.8 (2.0 - 7.1)	2.460 (0.550 - 2.600)	10.80	99
35+35	3.4	3.4	-	-	6.8 (2.0 - 7.1)	2.570 (0.540 - 2.600)	11.29	99
35+42	3.09	3.71	-	-	6.8 (2.0 - 7.1)	2.500 (0.540 - 2.600)	10.98	99
35+50	2.8	4.0	-	-	6.8 (2.0 - 7.1)	2.440 (0.550 - 2.600)	10.72	99
35+60	2.51	4.29	-	-	6.8 (2.0 - 7.1)	2.460 (0.550 - 2.610)	10.80	99
42+42	3.4	3.4	-	-	6.8 (2.0 - 7.1)	2.500 (0.540 - 2.600)	10.98	99
42+50	3.1	3.7	-	-	6.8 (2.0 - 7.1)	2.440 (0.550 - 2.600)	10.72	99
42+60	2.8	4.0	-	-	6.8 (2.0 - 7.1)	2.460 (0.550 - 2.610)	10.80	99
50+50	3.4	3.4	-	-	6.8 (2.1 - 7.1)	2.380 (0.560 - 2.610)	10.45	99
50+60	3.09	3.71	-	-	6.8 (2.1 - 7.1)	2.400 (0.570 - 2.620)	10.54	99



Indoor units combination	Cooling capacity (kW)					Outdoor unit power consumption (kW)	Current (A)	Power factor (%)
	Unit A	Unit B	Unit C	Unit D	Total			
60+60	3.4	3.4	-	-	6.8 (2.1 - 7.1)	2.420 (0.580 - 2.630)	10.63	99
22+22+22	2.2	2.2	2.2	-	6.6 (2.9 - 8.1)	1.750 (0.670 - 2.390)	7.69	99
22+22+25	2.2	2.2	2.5	-	6.9 (2.9 - 8.3)	1.880 (0.670 - 2.510)	8.26	99
22+22+35	1.98	1.98	3.14	-	7.1 (2.9 - 8.5)	1.990 (0.670 - 2.690)	8.74	99
22+22+42	1.81	1.81	3.48	-	7.1 (2.9 - 8.5)	1.970 (0.670 - 2.700)	8.65	99
22+22+50	1.66	1.66	3.78	-	7.1 (2.9 - 8.5)	1.960 (0.680 - 2.720)	8.61	99
22+22+60	1.5	1.5	4.1	-	7.1 (2.9 - 8.5)	1.950 (0.680 - 2.740)	8.56	99
22+25+25	2.16	2.47	2.47	-	7.1 (2.9 - 8.5)	1.990 (0.670 - 2.690)	8.74	99
22+25+35	1.91	2.16	3.03	-	7.1 (2.9 - 8.5)	1.990 (0.670 - 2.690)	8.74	99
22+25+42	1.76	1.99	3.35	-	7.1 (2.9 - 8.5)	1.970 (0.670 - 2.700)	8.65	99
22+25+50	1.61	1.83	3.66	-	7.1 (2.9 - 8.5)	1.960 (0.680 - 2.720)	8.61	99
22+25+60	1.46	1.66	3.98	-	7.1 (2.9 - 8.5)	1.950 (0.680 - 2.740)	8.56	99
22+35+35	1.7	2.7	2.7	-	7.1 (2.9 - 8.5)	1.990 (0.670 - 2.690)	8.74	99
22+35+42	1.58	2.51	3.01	-	7.1 (2.9 - 8.5)	1.970 (0.670 - 2.700)	8.65	99
22+35+50	1.46	2.32	3.32	-	7.1 (2.9 - 8.5)	1.960 (0.680 - 2.720)	8.61	99
22+35+60	1.34	2.12	3.64	-	7.1 (2.9 - 8.5)	1.950 (0.680 - 2.740)	8.56	99
22+42+42	1.5	2.8	2.8	-	7.1 (2.9 - 8.5)	1.970 (0.670 - 2.700)	8.65	99
22+42+50	1.4	2.6	3.1	-	7.1 (2.9 - 8.5)	1.960 (0.680 - 2.720)	8.61	99
22+42+60	1.3	2.4	3.4	-	7.1 (2.9 - 8.5)	1.950 (0.680 - 2.740)	8.56	99
22+50+50	1.28	2.91	2.91	-	7.1 (2.9 - 8.5)	1.940 (0.690 - 2.770)	8.52	99
25+25+25	2.36	2.36	2.36	-	7.1 (2.9 - 8.5)	1.990 (0.670 - 2.690)	8.74	99
25+25+35	2.09	2.09	2.92	-	7.1 (2.9 - 8.5)	1.99 (0.670 - 2.690)	8.74	99
25+25+42	1.93	1.93	3.24	-	7.1 (2.9 - 8.5)	1.97 (0.670 - 2.700)	8.65	99
25+25+50	1.78	1.78	3.54	-	7.1 (2.9 - 8.5)	1.96 (0.680 - 2.720)	8.61	99
25+25+60	1.61	1.61	3.88	-	7.1 (2.9 - 8.5)	1.95 (0.680 - 2.740)	8.56	99
25+35+35	1.86	2.62	2.62	-	7.1 (2.9 - 8.5)	1.99 (0.670 - 2.690)	8.74	99



Indoor units combination	Cooling capacity (kW)					Outdoor unit power consumption (kW)	Current (A)	Power factor (%)
	Unit A	Unit B	Unit C	Unit D	Total			
25+35+42	1.74	2.44	2.92	-	7.1 (2.9 - 8.5)	1.97 (0.670 - 2.700)	8.65	99
25+35+50	1.61	2.26	3.23	-	7.1 (2.9 - 8.5)	1.96 (0.680 - 2.720)	8.61	99
25+35+60	1.48	2.07	3.55	-	7.1 (2.9 - 8.5)	1.95 (0.680 - 2.740)	8.56	99
25+42+42	1.62	2.74	2.74	-	7.1 (2.9 - 8.5)	1.97 (0.670 - 2.700)	8.65	99
25+42+50	1.52	2.55	3.03	-	7.1 (2.9 - 8.5)	1.96 (0.680 - 2.720)	8.61	99
25+50+50	1.42	2.84	2.84	-	7.1 (2.9 - 8.5)	1.94 (0.690 - 2.770)	8.52	99
35+35+35	2.36	2.36	2.36	-	7.1 (2.9 - 8.5)	1.99 (0.670 - 2.690)	8.74	99
35+35+42	2.22	2.22	2.66	-	7.1 (2.9 - 8.5)	1.97 (0.670 - 2.700)	8.65	99
35+35+50	2.07	2.07	2.96	-	7.1 (2.9 - 8.5)	1.96 (0.680 - 2.720)	8.61	99
35+42+42	1.48	2.07	3.55	-	7.1 (2.9 - 8.5)	1.97 (0.670 - 2.700)	8.65	99
22+22+22+22	1.77	1.77	1.77	1.77	7.1 (3.7 - 8.8)	1.93 (0.800 - 2.750)	8.48	99
22+22+22+25	1.72	1.72	1.72	1.94	7.1 (3.7 - 8.8)	1.93 (0.800 - 2.750)	8.48	99
22+22+22+35	1.55	1.55	1.55	2.45	7.1 (3.7 - 8.8)	1.93 (0.800 - 2.750)	8.48	99
22+22+22+42	1.44	1.44	1.44	2.78	7.1 (3.7 - 8.8)	1.92 (0.800 - 2.760)	8.43	99
22+22+22+50	1.35	1.35	1.35	3.05	7.1 (3.7 - 8.8)	1.91 (0.810 - 2.780)	8.39	99
22+22+25+25	1.66	1.66	1.89	1.89	7.1 (3.7 - 8.8)	1.93 (0.800 - 2.750)	8.48	99
22+22+25+35	1.50	1.50	1.71	2.39	7.1 (3.7 - 8.8)	1.93 (0.800 - 2.750)	8.48	99
22+22+25+42	1.40	1.40	1.59	2.71	7.1 (3.7 - 8.8)	1.92 (0.800 - 2.760)	8.43	99
22+22+25+50	1.31	1.31	1.50	2.98	7.1 (3.7 - 8.8)	1.91 (0.810 - 2.780)	8.39	99
22+22+35+35	1.37	1.37	2.18	2.18	7.1 (3.7 - 8.8)	1.93 (0.800 - 2.750)	8.48	99
22+22+35+42	1.29	1.29	2.05	2.47	7.1 (3.7 - 8.8)	1.92 (0.800 - 2.760)	8.43	99
22+25+25+25	1.61	1.83	1.83	1.83	7.1 (3.7 - 8.8)	1.93 (0.800 - 2.750)	8.48	99
22+25+25+35	1.46	1.66	1.66	2.32	7.1 (3.7 - 8.8)	1.93 (0.800 - 2.750)	8.48	99
22+25+25+42	1.36	1.55	1.55	2.64	7.1 (3.7 - 8.8)	1.92 (0.800 - 2.760)	8.43	99
22+25+25+50	1.29	1.45	1.45	2.91	7.1 (3.7 - 8.8)	1.91 (0.810 - 2.780)	8.39	99
22+25+35+35	1.34	1.52	2.12	2.12	7.1 (3.7 - 8.8)	1.93 (0.800 - 2.750)	8.48	99



Indoor units combination	Cooling capacity (kW)					Outdoor unit power consumption (kW)	Current (A)	Power factor (%)
	Unit A	Unit B	Unit C	Unit D	Total			
22+25+35+42	1.26	1.43	2.00	2.41	7.1 (3.7 - 8.8)	1.92 (0.800 - 2.760)	8.43	99
25+25+25+25	1.77	1.77	1.77	1.77	7.1 (3.7 - 8.8)	1.93 (0.800 - 2.750)	8.48	99
25+25+25+35	1.61	1.61	1.61	2.27	7.1 (3.7 - 8.8)	1.93 (0.800 - 2.750)	8.48	99
25+25+25+42	1.51	1.51	1.51	2.57	7.1 (3.7 - 8.8)	1.92 (0.800 - 2.760)	8.43	99
25+25+25+50	1.42	1.42	1.42	2.84	7.1 (3.7 - 8.8)	1.91 (0.810 - 2.780)	8.39	99
25+25+35+35	1.48	1.48	2.07	2.07	7.1 (3.7 - 8.8)	1.93 (0.800 - 2.750)	8.48	99

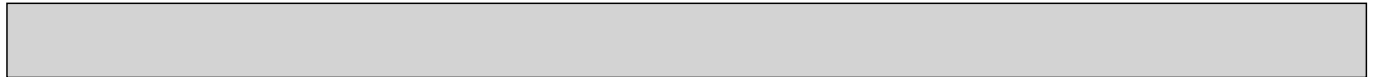

Indoor units combination	Heating capacity (kW)					Outdoor unit power consumption (kW)	Current (A)	Power factor (%)
	Unit A	Unit B	Unit C	Unit D	Total			
22	3.3	-	-	-	3.3 (1.2 - 4.2)	0.820 (0.380 - 1.090)	3.60	99
25	3.6	-	-	-	3.6 (1.2 - 4.5)	0.910 (0.380 - 1.190)	4.00	99
35	4.0	-	-	-	4.0 (1.2 - 4.8)	1.040 (0.380 - 1.300)	4.57	99
42	5.4	-	-	-	5.4 (1.3 - 6.5)	1.460 (0.370 - 1.800)	6.41	99
50	7.2	-	-	-	7.2 (1.4 - 8.2)	1.880 (0.370 - 2.300)	8.26	99
60	7.9	-	-	-	7.9 (1.4 - 8.6)	2.150 (0.360 - 2.410)	9.44	99
22+22	3.3	3.3	-	-	6.6 (1.8 - 7.2)	1.500 (0.410 - 1.710)	6.59	99
22+25	3.23	3.67	-	-	6.9 (1.8 - 8.7)	1.610 (0.410 - 2.350)	7.07	99
22+35	2.82	4.48	-	-	7.3 (1.8 - 9.0)	1.770 (0.410 - 2.390)	7.77	99
22+42	3.26	5.34	-	-	8.6 (1.8 - 9.0)	1.940 (0.400 - 2.300)	8.52	99
22+50	2.63	5.97	-	-	8.6 (1.8 - 9.0)	2.110 (0.390 - 2.220)	9.27	99
22+60	2.31	6.29	-	-	8.6 (1.8 - 9.0)	2.090 (0.380 - 2.220)	9.18	99
25+25	3.6	3.6	-	-	7.2 (1.8 - 9.0)	1.710 (0.410 - 2.390)	7.51	99
25+35	3.17	4.43	-	-	7.6 (1.8 - 9.0)	1.890 (0.410 - 2.390)	8.30	99
25+42	3.21	5.39	-	-	8.6 (1.8 - 9.0)	2.000 (0.400 - 2.300)	8.78	99
25+50	2.87	5.73	-	-	8.6 (1.8 - 9.0)	2.110 (0.390 - 2.220)	9.27	99
25+60	2.53	6.07	-	-	8.6 (1.8 - 9.0)	2.090 (0.380 - 2.220)	9.18	99
35+35	4.3	4.3	-	-	8.6 (1.8 - 9.0)	2.030 (0.410 - 2.390)	8.92	99
35+42	3.91	4.69	-	-	8.6 (1.8 - 9.0)	2.070 (0.400 - 2.300)	9.09	99
35+50	3.54	5.06	-	-	8.6 (1.8 - 9.0)	2.110 (0.390 - 2.220)	9.27	99
35+60	3.17	5.43	-	-	8.6 (1.8 - 9.0)	2.090 (0.380 - 2.220)	9.18	99
42+42	4.3	4.3	-	-	8.6 (1.8 - 9.0)	2.090 (0.400 - 2.300)	9.18	99
42+50	3.9	4.7	-	-	8.6 (1.8 - 9.0)	2.110 (0.390 - 2.220)	9.27	99
42+60	3.5	5.1	-	-	8.6 (1.8 - 9.0)	2.090 (0.380 - 2.220)	9.18	99
50+50	4.3	4.3	-	-	8.6 (1.9 - 9.0)	1.820 (0.360 - 2.040)	7.99	99
50+60	3.91	4.69	-	-	8.6 (1.9 - 9.0)	1.820 (0.360 - 2.040)	7.99	99



Indoor units combination	Heating capacity (kW)					Outdoor unit power consumption (kW)	Current (A)	Power factor (%)
	Unit A	Unit B	Unit C	Unit D	Total			
60+60	4.3	4.3	-	-	8.6 (1.9 - 9.0)	1.820 (0.360 - 2.040)	7.99	99
22+22+22	2.87	2.87	2.87	-	8.6 (2.6 - 9.0)	2.020 (0.500 - 2.120)	8.87	99
22+22+25	2.74	2.74	3.12	-	8.6 (2.6 - 9.0)	2.020 (0.500 - 2.120)	8.87	99
22+22+35	2.39	2.39	3.82	-	8.6 (2.6 - 9.0)	2.020 (0.500 - 2.120)	8.87	99
22+22+42	2.2	2.2	4.2	-	8.6 (2.6 - 9.0)	1.940 (0.490 - 2.040)	8.52	99
22+22+50	2.01	2.01	4.58	-	8.6 (2.6 - 9.0)	1.860 (0.480 - 1.960)	8.17	99
22+22+60	1.82	1.82	4.96	-	8.6 (2.6 - 9.0)	1.850 (0.480 - 1.960)	8.12	99
22+25+25	2.62	2.99	2.99	-	8.6 (2.6 - 9.0)	2.020 (0.500 - 2.120)	8.87	99
22+25+35	2.31	2.62	3.67	-	8.6 (2.6 - 9.0)	2.020 (0.500 - 2.120)	8.87	99
22+25+42	2.12	2.42	4.06	-	8.6 (2.6 - 9.0)	1.940 (0.490 - 2.040)	8.52	99
22+25+50	1.95	2.22	4.43	-	8.6 (2.6 - 9.0)	1.860 (0.480 - 1.960)	8.17	99
22+25+60	1.77	2.01	4.82	-	8.6 (2.6 - 9.0)	1.850 (0.480 - 1.960)	8.12	99
22+35+35	2.06	3.27	3.27	-	8.6 (2.6 - 9.0)	2.020 (0.500 - 2.120)	8.87	99
22+35+42	1.91	3.04	3.65	-	8.6 (2.6 - 9.0)	1.940 (0.490 - 2.040)	8.52	99
22+35+50	1.77	2.81	4.02	-	8.6 (2.6 - 9.0)	1.860 (0.480 - 1.960)	8.17	99
22+35+60	1.62	2.57	4.41	-	8.6 (2.6 - 9.0)	1.850 (0.480 - 1.960)	8.12	99
22+42+42	1.8	3.4	3.4	-	8.6 (2.6 - 9.0)	1.940 (0.490 - 2.040)	8.52	99
22+42+50	1.66	3.17	3.77	-	8.6 (2.6 - 9.0)	1.860 (0.480 - 1.960)	8.17	99
22+42+60	1.5	2.9	4.2	-	8.6 (2.6 - 9.0)	1.850 (0.480 - 1.960)	8.12	99
22+50+50	1.56	3.52	3.52	-	8.6 (2.6 - 9.0)	1.670 (0.460 - 1.830)	7.33	99
25+25+25	2.86	2.86	2.86	-	8.6 (2.6 - 9.0)	2.020 (0.500 - 2.120)	8.87	99
25+25+35	2.53	2.53	3.54	-	8.6 (2.6 - 9.0)	2.020 (0.500 - 2.120)	8.87	99
25+25+42	2.33	2.33	3.94	-	8.6 (2.6 - 9.0)	1.940 (0.490 - 2.040)	8.52	99
25+25+50	2.15	2.15	4.30	-	8.6 (2.6 - 9.0)	1.860 (0.480 - 1.960)	8.17	99
25+25+60	1.95	1.95	4.68	-	8.6 (2.6 - 9.0)	1.850 (0.480 - 1.960)	8.12	99
25+35+35	2.26	3.17	3.17	-	8.6 (2.6 - 9.0)	2.020 (0.500 - 2.120)	8.87	99

Indoor units combination	Heating capacity (kW)					Outdoor unit power consumption (kW)	Current (A)	Power factor (%)
	Unit A	Unit B	Unit C	Unit D	Total			
25+35+42	2.11	2.95	3.54	-	8.6 (2.6 - 9.0)	1.940 (0.490 - 2.040)	8.52	99
25+35+50	1.95	2.74	3.91	-	8.6 (2.6 - 9.0)	1.860 (0.480 - 1.960)	8.17	99
25+35+60	1.79	2.51	4.30	-	8.6 (2.6 - 9.0)	1.850 (0.480 - 1.960)	8.12	99
25+42+42	2.0	3.3	3.3	-	8.6 (2.6 - 9.0)	1.940 (0.490 - 2.040)	8.52	99
25+42+50	1.8	3.1	3.7	-	8.6 (2.6 - 9.0)	1.860 (0.480 - 1.960)	8.17	99
25+50+50	1.72	3.44	3.44	-	8.6 (2.6 - 9.0)	1.670 (0.460 - 1.830)	7.33	99
35+35+35	2.86	2.86	2.86	-	8.6 (2.6 - 9.0)	2.020 (0.500 - 2.120)	8.87	99
35+35+42	2.68	2.68	3.24	-	8.6 (2.6 - 9.0)	1.940 (0.500 - 2.040)	8.52	99
35+35+50	2.51	2.51	3.58	-	8.6 (2.6 - 9.0)	1.860 (0.500 - 1.960)	8.17	99
35+42+42	2.52	3.04	3.04	-	8.6 (2.6 - 9.0)	1.940 (0.490 - 2.040)	8.52	99
22+22+22+22	2.15	2.15	2.15	2.15	8.6 (3.4 - 9.0)	1.950 (0.600 - 1.960)	8.56	99
22+22+22+25	2.08	2.08	2.08	2.36	8.6 (3.4 - 9.0)	1.950 (0.600 - 1.960)	8.56	99
22+22+22+35	1.87	1.87	1.87	2.98	8.6 (3.4 - 9.0)	1.950 (0.600 - 1.960)	8.56	99
22+22+22+42	1.75	1.75	1.75	3.35	8.6 (3.4 - 9.0)	1.860 (0.600 - 1.940)	8.17	99
22+22+22+50	1.63	1.63	1.63	3.71	8.6 (3.4 - 9.0)	1.770 (0.600 - 1.930)	7.77	99
22+22+25+25	2.01	2.01	2.29	2.29	8.6 (3.4 - 9.0)	1.950 (0.600 - 1.960)	8.56	99
22+22+25+35	1.82	1.82	2.07	2.89	8.6 (3.4 - 9.0)	1.950 (0.600 - 1.960)	8.56	99
22+22+25+42	1.70	1.70	1.94	3.26	8.6 (3.4 - 9.0)	1.860 (0.600 - 1.940)	8.17	99
22+22+25+50	1.59	1.59	1.81	3.61	8.6 (3.4 - 9.0)	1.770 (0.600 - 1.930)	7.77	99
22+22+35+35	1.66	1.66	2.64	2.64	8.6 (3.4 - 9.0)	1.950 (0.600 - 1.960)	8.56	99
22+22+35+42	1.56	1.56	2.49	2.99	8.6 (3.4 - 9.0)	1.860 (0.600 - 1.940)	8.17	99
22+25+25+25	1.94	2.22	2.22	2.22	8.6 (3.4 - 9.0)	1.950 (0.600 - 1.960)	8.56	99
22+25+25+35	1.77	2.01	2.01	2.81	8.6 (3.4 - 9.0)	1.950 (0.600 - 1.960)	8.56	99
22+25+25+42	1.65	1.89	1.89	3.17	8.6 (3.4 - 9.0)	1.860 (0.600 - 1.940)	8.17	99
22+25+25+50	1.56	1.76	1.76	3.52	8.6 (3.4 - 9.0)	1.770 (0.600 - 1.930)	7.77	99
22+25+35+35	1.62	1.84	2.57	2.57	8.6 (3.4 - 9.0)	1.950 (0.600 - 1.960)	8.56	99

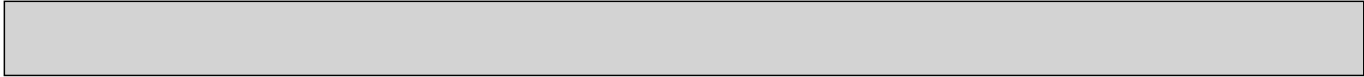

Indoor units combination	Heating capacity (kW)					Outdoor unit power consumption (kW)	Current (A)	Power factor (%)
	Unit A	Unit B	Unit C	Unit D	Total			
22+25+35+42	1.53	1.73	2.43	2.91	8.6 (3.4 - 9.0)	1.860 (0.600 - 1.940)	8.17	99
25+25+25+25	2.15	2.15	2.15	2.15	8.6 (3.4 - 9.0)	1.950 (0.600 - 1.960)	8.56	99
25+25+25+35	1.95	1.95	1.95	2.75	8.6 (3.4 - 9.0)	1.950 (0.600 - 1.960)	8.56	99
25+25+25+42	1.83	1.83	1.83	3.11	8.6 (3.4 - 9.0)	1.860 (0.600 - 1.940)	8.17	99
25+25+25+50	1.72	1.72	1.72	3.44	8.6 (3.4 - 9.0)	1.770 (0.600 - 1.930)	7.77	99
25+25+35+35	1.79	1.79	2.51	2.51	8.6 (3.4 - 9.0)	1.950 (0.600 - 1.960)	8.56	99

MXZ-4A80VA

NOTE: Electrical data is for outdoor unit only.

Indoor units combination	Cooling capacity (kW)				Total	Outdoor unit power consumption (kW)	Current (A)	Power factor (%)
	Unit A	Unit B	Unit C	Unit D				
22	2.2	-	-	-	2.2 (1.4 - 3.0)	0.680 (0.400 - 0.920)	2.99	99
25	2.5	-	-	-	2.5 (1.4 - 3.3)	0.760 (0.400 - 1.010)	3.34	99
35	3.5	-	-	-	3.5 (1.5 - 4.3)	1.030 (0.400 - 1.290)	4.52	99
42	4.2	-	-	-	4.2 (1.6 - 5.0)	1.230 (0.410 - 1.460)	5.40	99
50	5.0	-	-	-	5.0 (1.6 - 5.6)	1.440 (0.420 - 1.630)	6.32	99
60	6.0	-	-	-	6.0 (1.6 - 6.6)	1.930 (0.400 - 2.130)	8.48	99
71	7.1	-	-	-	7.1 (1.7 - 7.4)	2.580 (0.410 - 2.710)	11.33	99
22+22	2.2	2.2	-	-	4.4 (2.0 - 5.4)	1.130 (0.600 - 1.600)	4.96	99
22+25	2.2	2.5	-	-	4.7 (2.0 - 5.8)	1.270 (0.600 - 1.770)	5.58	99
22+35	2.2	3.5	-	-	5.7 (2.0 - 6.6)	1.710 (0.600 - 2.200)	7.51	99
22+42	2.2	4.2	-	-	6.4 (2.0 - 7.2)	2.080 (0.580 - 2.450)	9.13	99
22+50	2.2	5.0	-	-	7.2 (2.0 - 7.7)	2.450 (0.560 - 2.710)	10.76	99
22+60	1.75	6.00	-	-	7.75 (2.0 - 8.0)	2.750 (0.560 - 3.050)	12.08	99
22+71	1.66	6.19	-	-	7.9 (2.0 - 8.2)	2.810 (0.560 - 3.200)	12.34	99
25+25	2.5	2.5	-	-	5.0 (2.0 - 6.2)	1.360 (0.580 - 1.950)	5.97	99
25+35	2.5	3.5	-	-	6.0 (2.0 - 7.1)	2.010 (0.580 - 2.540)	8.83	99
25+42	2.5	4.2	-	-	6.7 (2.0 - 7.8)	2.290 (0.570 - 2.870)	10.06	99
25+50	2.5	5.0	-	-	7.5 (2.0 - 8.5)	2.580 (0.560 - 3.200)	11.33	99
25+60	2.11	5.64	-	-	7.75 (2.0 - 8.6)	2.750 (0.560 - 3.280)	12.08	99
25+71	2.01	5.84	-	-	7.85 (2.0 - 8.7)	2.810 (0.560 - 3.320)	12.34	99
35+35	3.5	3.5	-	-	7.0 (2.0 - 7.1)	2.400 (0.580 - 2.550)	10.54	99
35+42	3.5	4.2	-	-	7.7 (2.0 - 8.0)	2.580 (0.570 - 2.880)	11.33	99
35+50	3.10	4.65	-	-	7.75 (2.0 - 8.8)	2.760 (0.560 - 3.220)	12.12	99
35+60	2.61	5.24	-	-	7.85 (2.0 - 8.8)	2.730 (0.560 - 3.180)	11.99	99
35+71	2.51	5.44	-	-	7.95 (2.0 - 8.8)	2.780 (0.560 - 3.180)	12.21	99
42+42	3.95	3.95	-	-	7.9 (2.0 - 8.2)	2.860 (0.570 - 2.890)	12.56	99



Indoor units combination	Cooling capacity (kW)					Outdoor unit power consumption (kW)	Current (A)	Power factor (%)
	Unit A	Unit B	Unit C	Unit D	Total			
42+50	3.6	4.3	-	-	7.9 (2.0 - 8.8)	2.860 (0.560 - 3.190)	12.56	99
42+60	3.3	4.7	-	-	8.0 (2.0 - 8.8)	2.880 (0.560 - 3.150)	12.65	99
42+71	3.0	5.0	-	-	8.0 (2.0 - 8.8)	2.880 (0.560 - 3.150)	12.65	99
50+50	3.95	3.95	-	-	7.9 (2.1 - 8.8)	2.780 (0.590 - 3.160)	12.21	99
50+60	3.43	4.57	-	-	8.0 (2.1 - 8.8)	2.800 (0.570 - 3.120)	12.30	99
50+71	3.27	4.73	-	-	8.0 (2.1 - 8.8)	2.800 (0.570 - 3.120)	12.30	99
60+60	4.00	4.00	-	-	8.0 (2.1 - 8.8)	2.690 (0.550 - 3.080)	11.81	99
60+71	3.84	4.16	-	-	8.0 (2.1 - 8.8)	2.690 (0.550 - 3.080)	11.81	99
22+22+22	2.2	2.2	2.2	-	6.6 (2.9 - 8.1)	1.860 (0.690 - 2.410)	8.17	99
22+22+25	2.2	2.2	2.5	-	6.9 (2.9 - 8.3)	1.970 (0.670 - 2.510)	8.65	99
22+22+35	2.14	2.14	3.42	-	7.7 (2.9 - 8.3)	2.310 (0.690 - 2.970)	10.14	99
22+22+42	2.01	2.01	3.83	-	7.85 (2.9 - 8.7)	2.310 (0.690 - 2.940)	10.14	99
22+22+50	1.72	1.72	4.41	-	7.85 (2.9 - 9.0)	2.320 (0.700 - 2.920)	10.19	99
22+22+60	1.46	1.46	5.03	-	7.95 (2.9 - 9.0)	2.370 (0.680 - 2.880)	10.41	99
22+22+71	1.4	1.4	5.2	-	8.0 (2.9 - 9.0)	2.390 (0.680 - 2.880)	10.50	99
22+25+25	2.2	2.5	2.5	-	7.2 (2.9 - 8.9)	2.100 (0.690 - 2.940)	9.22	99
22+25+35	2.08	2.36	3.31	-	7.75 (2.9 - 8.9)	2.350 (0.690 - 2.970)	10.32	99
22+25+42	1.95	2.22	3.73	-	7.9 (2.9 - 9.0)	2.360 (0.690 - 2.940)	10.36	99
22+25+50	1.79	2.04	4.07	-	7.9 (2.9 - 9.0)	2.370 (0.700 - 2.920)	10.41	99
22+25+60	1.64	1.87	4.49	-	8.0 (2.9 - 9.0)	2.390 (0.680 - 2.880)	10.50	99
22+25+71	1.49	1.69	4.82	-	8.0 (2.9 - 9.0)	2.390 (0.680 - 2.880)	10.50	99
22+35+35	1.87	2.99	2.99	-	7.85 (2.9 - 9.0)	2.350 (0.690 - 2.920)	10.32	99
22+35+42	1.76	2.79	3.35	-	7.9 (2.9 - 9.0)	2.330 (0.690 - 2.900)	10.23	99
22+35+50	1.63	2.58	3.69	-	7.9 (2.9 - 9.0)	2.320 (0.700 - 2.890)	10.19	99
22+35+60	1.5	2.4	4.1	-	8.0 (2.9 - 9.0)	2.350 (0.680 - 2.860)	10.32	99
22+35+71	1.38	2.18	4.44	-	8.0 (2.9 - 9.0)	2.350 (0.680 - 2.860)	10.32	99



Indoor units combination	Cooling capacity (kW)					Outdoor unit power consumption (kW)	Current (A)	Power factor (%)
	Unit A	Unit B	Unit C	Unit D	Total			
22+42+42	1.65	3.15	3.15	-	7.95 (2.9 - 9.0)	2.300 (0.680 - 2.880)	10.10	99
22+42+50	1.53	2.93	3.49	-	7.95 (2.9 - 9.0)	2.290 (0.690 - 2.870)	10.06	99
22+42+60	1.4	2.7	3.9	-	8.0 (2.9 - 9.0)	2.320 (0.670 - 2.840)	10.19	99
22+42+71	1.3	2.5	4.2	-	8.0 (2.9 - 9.0)	2.320 (0.670 - 2.840)	10.19	99
22+50+50	1.44	3.28	3.28	-	8.0 (2.9 - 9.0)	2.330 (0.680 - 2.860)	10.23	99
22+50+60	1.33	3.03	3.64	-	8.0 (2.9 - 9.0)	2.300 (0.660 - 2.830)	10.10	99
22+50+71	1.23	2.80	3.97	-	8.0 (2.9 - 9.0)	2.300 (0.660 - 2.830)	10.10	99
25+25+25	2.5	2.5	2.5	-	7.5 (2.9 - 9.0)	2.250 (0.690 - 3.010)	9.88	99
25+25+35	2.28	2.28	3.19	-	7.75 (2.9 - 9.0)	2.350 (0.690 - 2.970)	10.32	99
25+25+42	2.14	2.14	3.62	-	7.9 (2.9 - 9.0)	2.360 (0.690 - 2.940)	10.36	99
25+25+50	1.98	1.98	3.94	-	7.9 (2.9 - 9.0)	2.370 (0.700 - 2.920)	10.41	99
25+25+60	1.82	1.82	4.36	-	8.0 (2.9 - 9.0)	2.390 (0.680 - 2.880)	10.50	99
25+25+71	1.65	1.65	4.70	-	8.0 (2.9 - 9.0)	2.390 (0.680 - 2.880)	10.50	99
25+35+35	2.07	2.89	2.89	-	7.85 (2.9 - 9.0)	2.350 (0.690 - 2.920)	10.32	99
25+35+42	1.96	2.75	3.29	-	8.0 (2.9 - 9.0)	2.360 (0.690 - 2.900)	10.36	99
25+35+50	1.82	2.54	3.64	-	8.0 (2.9 - 9.0)	2.380 (0.700 - 2.890)	10.45	99
25+35+60	1.67	2.33	4.00	-	8.0 (2.9 - 9.0)	2.350 (0.680 - 2.860)	10.32	99
25+35+71	1.53	2.14	4.33	-	8.0 (2.9 - 9.0)	2.350 (0.680 - 2.860)	10.32	99
25+42+42	1.8	3.1	3.1	-	8.0 (2.9 - 9.0)	2.330 (0.670 - 2.870)	10.23	99
25+42+50	1.7	2.9	3.4	-	8.0 (2.9 - 9.0)	2.350 (0.680 - 2.860)	10.32	99
25+42+60	1.6	2.6	3.8	-	8.0 (2.9 - 9.0)	2.320 (0.670 - 2.840)	10.19	99
25+42+71	1.45	2.43	4.12	-	8.0 (2.9 - 9.0)	2.320 (0.670 - 2.840)	10.19	99
25+50+50	1.6	3.2	3.2	-	8.0 (2.9 - 9.0)	2.330 (0.660 - 2.840)	10.23	99
25+50+60	1.48	2.96	3.56	-	8.0 (2.9 - 9.0)	2.300 (0.660 - 2.830)	10.10	99
35+35+35	2.65	2.65	2.65	-	7.95 (2.9 - 9.0)	2.280 (0.720 - 2.910)	10.01	99
35+35+42	2.5	2.5	3.0	-	8.0 (2.9 - 9.0)	2.270 (0.710 - 2.890)	9.97	99



Indoor units combination	Cooling capacity (kW)					Outdoor unit power consumption (kW)	Current (A)	Power factor (%)
	Unit A	Unit B	Unit C	Unit D	Total			
35+35+50	2.33	2.33	3.34	-	8.0 (2.9 - 9.0)	2.260 (0.700 - 2.870)	9.93	99
35+35+60	2.15	2.15	3.70	-	8.0 (2.9 - 9.0)	2.260 (0.680 - 2.840)	9.93	99
35+35+71	1.99	1.99	4.02	-	8.0 (2.9 - 9.0)	2.260 (0.680 - 2.840)	9.93	99
35+42+42	2.4	2.8	2.8	-	8.0 (2.9 - 9.0)	2.260 (0.700 - 2.870)	9.93	99
35+42+50	2.20	2.65	3.15	-	8.0 (2.9 - 9.0)	2.250 (0.690 - 2.850)	9.88	99
35+42+60	2.0	2.5	3.5	-	8.0 (2.9 - 9.0)	2.240 (0.670 - 2.820)	9.84	99
35+50+50	2.08	2.96	2.96	-	8.0 (2.9 - 9.0)	2.240 (0.680 - 2.840)	9.84	99
35+50+60	1.93	2.76	3.31	-	8.0 (2.9 - 9.0)	2.220 (0.660 - 2.810)	9.75	99
22+22+22+22	1.95	1.95	1.95	1.95	7.8 (3.7 - 9.2)	2.180 (0.810 - 2.670)	9.57	99
22+22+22+25	1.90	1.90	1.90	2.15	7.85 (3.7 - 9.2)	2.190 (0.810 - 2.670)	9.62	99
22+22+22+35	1.73	1.73	1.73	2.76	7.95 (3.7 - 9.2)	2.210 (0.810 - 2.650)	9.71	99
22+22+22+42	1.63	1.63	1.63	3.11	8.0 (3.7 - 9.2)	2.180 (0.800 - 2.630)	9.57	99
22+22+22+50	1.52	1.52	1.52	3.44	8.0 (3.7 - 9.2)	2.150 (0.790 - 2.620)	9.44	99
22+22+22+60	1.4	1.4	1.4	3.8	8.0 (3.7 - 9.2)	2.130 (0.770 - 2.590)	9.35	99
22+22+22+71	1.28	1.28	1.28	4.16	8.0 (3.7 - 9.2)	2.130 (0.770 - 2.590)	9.35	99
22+22+25+25	1.87	1.87	2.13	2.13	8.0 (3.7 - 9.2)	2.190 (0.810 - 2.670)	9.62	99
22+22+25+35	1.68	1.68	1.91	1.91	7.18 (3.7 - 9.2)	2.210 (0.810 - 2.650)	9.71	99
22+22+25+42	1.58	1.58	1.80	3.04	8.0 (3.7 - 9.2)	2.180 (0.800 - 2.630)	9.57	99
22+22+25+50	1.48	1.48	1.68	3.36	8.0 (3.7 - 9.2)	2.150 (0.790 - 2.620)	9.44	99
22+22+25+60	1.36	1.36	1.55	3.73	8.0 (3.7 - 9.2)	2.130 (0.770 - 2.590)	9.35	99
22+22+25+71	1.26	1.26	1.43	4.05	8.0 (3.7 - 9.2)	2.130 (0.770 - 2.590)	9.35	99
22+22+35+35	1.54	1.54	2.46	2.46	8.0 (3.7 - 9.2)	2.210 (0.810 - 2.620)	9.71	99
22+22+35+42	1.45	1.45	2.31	2.79	8.0 (3.7 - 9.2)	2.160 (0.800 - 2.600)	9.49	99
22+22+35+50	1.36	1.36	2.18	3.10	8.0 (3.7 - 9.2)	2.120 (0.790 - 2.590)	9.31	99
22+22+35+60	1.12	1.12	1.92	3.84	8.0 (3.7 - 9.2)	2.100 (0.770 - 2.560)	9.22	99
22+22+42+42	1.4	1.4	2.6	2.6	8.0 (3.7 - 9.2)	2.130 (0.790 - 2.580)	9.35	99

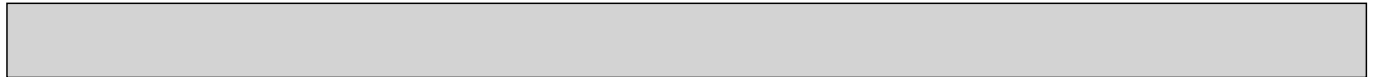

Indoor units combination	Cooling capacity (kW)					Outdoor unit power consumption (kW)	Current (A)	Power factor (%)
	Unit A	Unit B	Unit C	Unit D	Total			
22+22+42+50	1.3	1.3	2.5	2.9	8.0 (3.7 - 9.2)	2.090 (0.780 - 2.570)	9.18	99
22+22+50+50	1.22	1.22	2.78	2.78	8.0 (3.7 - 9.2)	2.070 (0.770 - 2.560)	9.09	99
22+25+25+25	1.78	2.04	2.04	2.04	7.9 (3.7 - 9.2)	2.140 (0.810 - 2.670)	9.40	99
22+25+25+35	1.63	1.86	1.86	2.60	7.95 (3.7 - 9.2)	2.210 (0.810 - 2.650)	9.71	99
22+25+25+42	1.54	1.75	1.75	2.96	8.0 (3.7 - 9.2)	2.180 (0.800 - 2.630)	9.57	99
22+25+25+50	1.44	1.64	1.64	3.28	8.0 (3.7 - 9.2)	2.150 (0.790 - 2.620)	9.44	99
22+25+25+60	1.33	1.52	1.52	3.64	8.0 (3.7 - 9.2)	2.130 (0.770 - 2.590)	9.35	99
22+25+35+35	1.51	1.71	2.39	2.39	8.0 (3.7 - 9.2)	2.210 (0.810 - 2.620)	9.71	99
22+25+35+42	1.42	1.61	2.26	2.71	8.0 (3.7 - 9.2)	2.160 (0.800 - 2.600)	9.49	99
22+25+35+50	1.33	1.52	2.12	3.03	8.0 (3.7 - 9.2)	2.120 (0.790 - 2.590)	9.31	99
22+25+35+60	1.24	1.41	1.97	3.38	8.0 (3.7 - 9.2)	2.100 (0.770 - 2.560)	9.22	99
22+35+35+35	1.4	2.2	2.2	2.2	8.0 (3.7 - 9.2)	2.200 (0.810 - 2.610)	9.66	99
22+35+35+42	1.31	2.09	2.09	2.51	8.0 (3.7 - 9.2)	2.140 (0.800 - 2.600)	9.40	99
22+35+35+50	1.24	1.97	1.97	2.82	8.0 (3.7 - 9.2)	2.080 (0.790 - 2.590)	9.13	99
22+35+42+42	1.2	2.0	2.4	2.4	8.0 (3.7 - 9.2)	2.080 (0.790 - 2.590)	9.13	99
25+25+25+25	1.98	1.98	1.98	1.98	7.92 (3.7 - 9.2)	2.150 (0.810 - 2.670)	9.44	99
25+25+25+35	1.82	1.82	1.82	2.54	8.0 (3.7 - 9.2)	2.220 (0.810 - 2.650)	9.75	99
25+25+25+42	1.71	1.71	1.71	2.87	8.0 (3.7 - 9.2)	2.180 (0.800 - 2.630)	9.57	99
25+25+25+50	1.6	1.6	1.6	3.2	8.0 (3.7 - 9.2)	2.150 (0.790 - 2.620)	9.44	99
25+25+25+60	1.48	1.48	1.48	3.56	8.0 (3.7 - 9.2)	2.130 (0.770 - 2.590)	9.35	99
25+25+35+35	1.67	1.67	2.33	2.33	8.0 (3.7 - 9.2)	2.210 (0.810 - 2.620)	9.71	99
25+25+35+42	1.57	1.57	2.20	2.66	8.0 (3.7 - 9.2)	2.160 (0.800 - 2.600)	9.49	99
25+25+35+50	1.48	1.48	2.08	2.96	8.0 (3.7 - 9.2)	2.120 (0.790 - 2.590)	9.31	99
25+35+35+35	1.55	2.15	2.15	2.15	8.0 (3.7 - 9.2)	2.200 (0.810 - 2.610)	9.66	99
25+35+35+42	1.46	2.04	2.04	2.46	8.0 (3.7 - 9.2)	2.150 (0.800 - 2.590)	9.44	99
35+35+35+35	2.0	2.0	2.0	2.0	8.0 (3.7 - 9.2)	2.190 (0.810 - 2.580)	9.62	99



Indoor units combination	Heating capacity (kW)					Outdoor unit power consumption (kW)	Current (A)	Power factor (%)
	Unit A	Unit B	Unit C	Unit D	Total			
22	3.3	-	-	-	3.3 (1.3 - 4.2)	1.050 (0.340 - 1.380)	4.61	99
25	3.6	-	-	-	3.6 (1.2 - 4.5)	1.110 (0.340 - 1.510)	4.87	99
35	4.0	-	-	-	4.0 (1.2 - 4.8)	1.210 (0.330 - 1.570)	5.31	99
42	5.4	-	-	-	5.4 (1.3 - 6.5)	1.990 (0.330 - 2.140)	8.74	99
50	7.2	-	-	-	7.2 (1.4 - 8.2)	2.770 (0.330 - 2.710)	12.17	99
60	7.9	-	-	-	7.9 (1.4 - 8.6)	2.700 (0.330 - 3.060)	11.86	99
71	8.6	-	-	-	8.6 (1.6 - 9.2)	3.220 (0.360 - 3.520)	14.14	99
22+22	3.3	3.3	-	-	6.6 (1.8 - 7.2)	2.020 (0.480 - 2.760)	8.87	99
22+25	3.23	3.67	-	-	6.9 (1.8 - 8.7)	2.120 (0.480 - 3.000)	9.31	99
22+35	2.82	4.48	-	-	7.3 (1.8 - 9.2)	2.130 (0.480 - 3.110)	9.35	99
22+42	2.78	5.32	-	-	8.1 (1.8 - 9.6)	2.300 (0.470 - 3.120)	10.10	99
22+50	2.72	6.18	-	-	8.9 (1.8 - 9.9)	2.470 (0.460 - 3.140)	10.85	99
22+60	2.52	6.88	-	-	9.4 (1.8 - 9.9)	2.710 (0.460 - 3.140)	11.90	99
22+71	2.22	7.18	-	-	9.4 (1.8 - 9.9)	2.710 (0.460 - 3.140)	11.90	99
25+25	3.6	3.6	-	-	7.2 (1.8 - 9.1)	2.170 (0.480 - 3.140)	9.53	99
25+35	3.17	4.43	-	-	7.6 (1.8 - 9.5)	2.210 (0.480 - 3.230)	9.71	99
25+42	3.1	5.2	-	-	8.3 (1.8 - 9.8)	2.360 (0.470 - 3.240)	10.36	99
25+50	3.0	6.0	-	-	9.0 (1.8 - 10.1)	2.520 (0.460 - 3.260)	11.07	99
25+60	2.76	6.64	-	-	9.4 (1.8 - 10.1)	2.710 (0.460 - 3.260)	11.90	99
25+71	2.45	6.95	-	-	9.4 (1.8 - 10.1)	2.710 (0.460 - 3.260)	11.90	99
35+35	4.0	4.0	-	-	8.0 (1.8 - 9.8)	2.370 (0.480 - 3.230)	10.41	99
35+42	3.95	4.75	-	-	8.7 (1.8 - 10.2)	2.460 (0.470 - 3.320)	10.80	99
35+50	3.87	5.53	-	-	9.4 (1.8 - 10.5)	2.560 (0.460 - 3.420)	11.24	99
35+60	3.46	5.94	-	-	9.4 (1.8 - 10.5)	2.560 (0.460 - 3.420)	11.24	99
35+71	3.1	6.3	-	-	9.4 (1.8 - 10.5)	2.560 (0.460 - 3.420)	11.24	99
42+42	4.7	4.7	-	-	9.4 (1.8 - 10.9)	2.460 (0.470 - 3.370)	10.80	99



Indoor units combination	Heating capacity (kW)				Total	Outdoor unit power consumption (kW)	Current (A)	Power factor (%)
	Unit A	Unit B	Unit C	Unit D				
42+50	4.3	5.1	-	-	9.4 (1.8 - 10.9)	2.460 (0.460 - 3.370)	10.80	99
42+60	3.9	5.5	-	-	9.4 (1.8 - 10.9)	2.460 (0.460 - 3.370)	10.80	99
42+71	3.5	5.9	-	-	9.4 (1.8 - 10.9)	2.460 (0.460 - 3.370)	10.80	99
50+50	4.7	4.7	-	-	9.4 (1.9 - 11.2)	2.370 (0.440 - 3.320)	10.41	99
50+60	4.3	5.1	-	-	9.4 (1.9 - 11.2)	2.370 (0.440 - 3.320)	10.41	99
50+71	3.88	5.52	-	-	9.4 (1.9 - 11.2)	2.370 (0.440 - 3.320)	10.41	99
60+60	4.7	4.7	-	-	9.4 (1.9 - 11.2)	2.370 (0.440 - 3.320)	10.41	99
60+71	4.31	5.09	-	-	9.4 (1.9 - 11.2)	2.370 (0.440 - 3.320)	10.41	99
22+22+22	2.9	2.9	2.9	-	8.7 (2.6 - 10.6)	2.150 (0.530 - 3.060)	9.44	99
22+22+25	2.81	2.81	3.18	-	8.8 (2.6 - 11.1)	2.170 (0.530 - 3.300)	9.53	99
22+22+35	2.62	2.62	4.16	-	9.4 (2.6 - 11.6)	2.310 (0.530 - 3.400)	10.14	99
22+22+42	2.4	2.4	4.6	-	9.4 (2.6 - 11.6)	2.210 (0.520 - 3.360)	9.71	99
22+22+50	2.2	2.2	5.0	-	9.4 (2.6 - 11.6)	2.120 (0.510 - 3.330)	9.31	99
22+22+60	1.99	1.99	5.42	-	9.4 (2.6 - 11.6)	2.120 (0.510 - 3.330)	9.31	99
22+22+71	1.8	1.8	5.8	-	9.4 (2.6 - 11.6)	2.120 (0.510 - 3.330)	9.31	99
22+25+25	2.72	3.09	3.09	-	8.9 (2.6 - 11.6)	2.170 (0.530 - 3.420)	9.53	99
22+25+35	2.52	2.87	4.01	-	9.4 (2.6 - 11.6)	2.270 (0.530 - 3.410)	9.97	99
22+25+42	2.32	2.64	4.44	-	9.4 (2.6 - 11.6)	2.180 (0.520 - 3.370)	9.57	99
22+25+50	2.13	2.42	4.85	-	9.4 (2.6 - 11.6)	2.100 (0.510 - 3.330)	9.22	99
22+25+60	1.93	2.20	5.27	-	9.4 (2.6 - 11.6)	2.100 (0.510 - 3.330)	9.22	99
22+25+71	1.75	1.99	5.66	-	9.4 (2.6 - 11.6)	2.100 (0.510 - 3.330)	9.22	99
22+35+35	2.24	3.58	3.58	-	9.4 (2.6 - 11.6)	2.210 (0.530 - 3.400)	9.71	99
22+35+42	2.09	3.32	3.99	-	9.4 (2.7 - 11.6)	2.130 (0.520 - 3.310)	9.35	99
22+35+50	1.93	3.07	4.39	-	9.4 (2.7 - 11.6)	2.050 (0.510 - 3.230)	9.00	99
22+35+60	1.77	2.81	4.82	-	9.4 (2.7 - 11.6)	2.050 (0.510 - 3.230)	9.00	99
22+35+71	1.62	2.57	5.21	-	9.4 (2.7 - 11.6)	2.050 (0.510 - 3.230)	9.00	99



Indoor units combination	Heating capacity (kW)					Outdoor unit power consumption (kW)	Current (A)	Power factor (%)
	Unit A	Unit B	Unit C	Unit D	Total			
22+42+42	2.0	3.7	3.7	-	9.4 (2.7 - 11.6)	2.080 (0.510 - 3.240)	9.13	99
22+42+50	1.8	3.5	4.1	-	9.4 (2.7 - 11.6)	2.000 (0.500 - 3.160)	8.78	99
22+42+60	1.7	3.2	4.5	-	9.4 (2.7 - 11.6)	2.000 (0.500 - 3.160)	8.78	99
22+42+71	1.53	2.92	4.95	-	9.4 (2.7 - 11.6)	2.000 (0.500 - 3.160)	8.78	99
22+50+50	1.70	3.85	3.85	-	9.4 (2.7 - 11.6)	1.960 (0.490 - 3.100)	8.61	99
22+50+60	1.57	3.56	4.27	-	9.4 (2.7 - 11.6)	1.960 (0.490 - 3.100)	8.61	99
22+50+71	1.45	3.29	4.66	-	9.4 (2.7 - 11.6)	1.960 (0.490 - 3.100)	8.61	99
25+25+25	3.0	3.0	3.0	-	9.0 (2.6 - 11.6)	2.170 (0.530 - 3.420)	9.53	99
25+25+35	2.76	2.76	3.87	-	9.4 (2.6 - 11.6)	2.250 (0.530 - 3.410)	9.88	99
25+25+42	2.55	2.55	4.30	-	9.4 (2.6 - 11.6)	2.170 (0.520 - 3.360)	9.53	99
25+25+50	2.35	2.35	4.70	-	9.4 (2.6 - 11.6)	2.090 (0.510 - 3.320)	9.18	99
25+25+60	2.14	2.14	5.12	-	9.4 (2.6 - 11.6)	2.090 (0.510 - 3.320)	9.18	99
25+25+71	1.94	1.94	5.52	-	9.4 (2.6 - 11.6)	2.090 (0.510 - 3.320)	9.18	99
25+35+35	2.48	3.46	3.46	-	9.4 (2.6 - 11.6)	2.190 (0.530 - 3.400)	9.62	99
25+35+42	2.30	3.23	3.87	-	9.4 (2.7 - 11.6)	2.110 (0.520 - 3.310)	9.27	99
25+35+50	2.14	2.99	4.27	-	9.4 (2.7 - 11.6)	2.030 (0.510 - 3.230)	8.92	99
25+35+60	1.96	2.74	4.70	-	9.4 (2.7 - 11.6)	2.030 (0.510 - 3.230)	8.92	99
25+35+71	1.8	2.5	5.1	-	9.4 (2.7 - 11.6)	2.030 (0.510 - 3.230)	8.92	99
25+42+42	2.2	3.6	3.6	-	9.4 (2.7 - 11.6)	2.060 (0.510 - 3.240)	9.05	99
25+42+50	2.0	3.4	4.0	-	9.4 (2.7 - 11.6)	1.980 (0.500 - 3.160)	8.70	99
25+42+60	1.9	3.1	4.4	-	9.4 (2.7 - 11.6)	1.980 (0.500 - 3.160)	8.70	99
25+42+71	1.7	2.9	4.8	-	9.4 (2.7 - 11.6)	1.980 (0.500 - 3.160)	8.70	99
25+50+50	1.88	3.76	3.76	-	9.4 (2.7 - 11.6)	1.940 (0.490 - 3.100)	8.52	99
25+50+60	1.74	3.48	4.18	-	9.4 (2.7 - 11.6)	1.940 (0.490 - 3.100)	8.52	99
35+35+35	3.13	3.13	3.13	-	9.4 (2.6 - 11.6)	2.170 (0.530 - 3.380)	9.53	99
35+35+42	2.93	2.93	3.54	-	9.4 (2.7 - 11.6)	2.090 (0.520 - 3.270)	9.18	99



Indoor units combination	Heating capacity (kW)					Outdoor unit power consumption (kW)	Current (A)	Power factor (%)
	Unit A	Unit B	Unit C	Unit D	Total			
35+35+50	2.74	2.74	3.92	-	9.4 (2.7 - 11.6)	2.010 (0.510 - 3.160)	8.83	99
35+35+60	2.53	2.53	4.34	-	9.4 (2.7 - 11.6)	2.010 (0.510 - 3.160)	8.83	99
35+35+71	2.33	2.33	4.74	-	9.4 (2.7 - 11.6)	2.010 (0.510 - 3.160)	8.83	99
35+42+42	2.8	3.3	3.3	-	9.4 (2.7 - 11.6)	2.040 (0.510 - 3.200)	8.96	99
35+42+50	2.6	3.1	3.7	-	9.4 (2.7 - 11.6)	1.960 (0.500 - 3.090)	8.61	99
35+42+60	2.4	2.9	4.1	-	9.4 (2.7 - 11.6)	1.960 (0.500 - 3.090)	8.61	99
35+50+50	2.44	3.48	3.48	-	9.4 (2.7 - 11.6)	1.920 (0.490 - 3.030)	8.43	99
35+50+60	2.27	3.24	3.89	-	9.4 (2.7 - 11.6)	1.920 (0.490 - 3.030)	8.43	99
22+22+22+22	2.35	2.35	2.35	2.35	9.4 (3.4 - 11.6)	2.020 (0.590 - 3.420)	8.87	99
22+22+22+25	2.27	2.27	2.27	2.59	9.4 (3.4 - 11.6)	1.990 (0.590 - 3.410)	8.74	99
22+22+22+35	2.05	2.05	2.05	3.25	9.4 (3.4 - 11.6)	1.960 (0.590 - 3.390)	8.61	99
22+22+22+42	1.91	1.91	1.91	3.67	9.4 (3.5 - 11.6)	1.930 (0.580 - 3.320)	8.48	99
22+22+22+50	1.78	1.78	1.78	4.06	9.4 (3.5 - 11.6)	1.910 (0.580 - 3.260)	8.39	99
22+22+22+60	1.64	1.64	1.64	4.48	9.4 (3.5 - 11.6)	1.910 (0.580 - 3.260)	8.39	99
22+22+22+71	1.51	1.51	1.51	4.87	9.4 (3.5 - 11.6)	1.910 (0.580 - 3.260)	8.39	99
22+22+25+25	2.2	2.2	2.5	2.5	9.4 (3.5 - 11.6)	1.980 (0.590 - 3.400)	8.70	99
22+22+25+35	1.99	1.99	2.26	3.16	9.4 (3.4 - 11.6)	1.940 (0.590 - 3.390)	8.52	99
22+22+25+42	1.86	1.86	2.12	3.56	9.4 (3.5 - 11.6)	1.910 (0.580 - 3.330)	8.39	99
22+22+25+50	1.74	1.74	1.97	3.95	9.4 (3.5 - 11.6)	1.890 (0.580 - 3.270)	8.30	99
22+22+25+60	1.60	1.60	1.83	4.37	9.4 (3.5 - 11.6)	1.890 (0.580 - 3.270)	8.30	99
22+22+25+71	1.48	1.48	1.68	4.76	9.4 (3.5 - 11.6)	1.890 (0.580 - 3.270)	8.30	99
22+22+35+35	1.81	1.81	2.89	2.89	9.4 (3.4 - 11.6)	1.910 (0.590 - 3.340)	8.39	99
22+22+35+42	1.71	1.71	2.72	3.26	9.4 (3.5 - 11.6)	1.860 (0.580 - 3.280)	8.17	99
22+22+35+50	1.60	1.60	2.55	3.65	9.4 (3.5 - 11.6)	1.820 (0.580 - 3.220)	7.99	99
22+22+35+60	1.49	1.49	2.37	4.05	9.4 (3.5 - 11.6)	1.820 (0.580 - 3.220)	7.99	99
22+22+42+42	1.6	1.6	3.1	3.1	9.4 (3.4 - 11.6)	1.820 (0.560 - 3.230)	7.99	99



Indoor units combination	Heating capacity (kW)					Outdoor unit power consumption (kW)	Current (A)	Power factor (%)
	Unit A	Unit B	Unit C	Unit D	Total			
22+22+42+50	1.5	1.5	2.9	3.5	9.4 (3.4 - 11.6)	1.780 (0.560 - 3.170)	7.82	99
22+22+50+50	1.44	1.44	3.26	3.26	9.4 (3.4 - 11.6)	1.750 (0.550 - 3.130)	7.69	99
22+25+25+25	2.14	2.42	2.42	2.42	9.4 (3.4 - 11.6)	1.960 (0.590 - 3.390)	8.61	99
22+25+25+35	1.93	2.20	2.20	3.07	9.4 (3.4 - 11.6)	1.920 (0.590 - 3.370)	8.43	99
22+25+25+42	1.81	2.06	2.06	3.47	9.4 (3.5 - 11.6)	1.890 (0.580 - 3.300)	8.30	99
22+25+25+50	1.70	1.93	1.93	3.84	9.4 (3.5 - 11.6)	1.870 (0.580 - 3.230)	8.21	99
22+25+25+60	1.57	1.78	1.78	4.27	9.4 (3.5 - 11.6)	1.870 (0.580 - 3.230)	8.21	99
22+25+35+35	1.77	2.01	2.81	2.81	9.4 (3.4 - 11.6)	1.890 (0.590 - 3.320)	8.30	99
22+25+35+42	1.67	1.90	2.65	3.18	9.4 (3.5 - 11.6)	1.840 (0.580 - 3.260)	8.08	99
22+25+35+50	1.57	1.78	2.49	3.56	9.4 (3.5 - 11.6)	1.800 (0.580 - 3.200)	7.91	99
22+25+35+50	1.46	1.65	2.32	3.97	9.4 (3.5 - 11.6)	1.800 (0.580 - 3.200)	7.91	99
22+35+35+35	1.63	2.59	2.59	2.59	9.4 (3.4 - 11.6)	1.860 (0.590 - 3.280)	8.17	99
22+35+35+42	1.53	2.46	2.46	2.95	9.4 (3.5 - 11.6)	1.820 (0.580 - 3.240)	7.99	99
22+35+35+50	1.45	2.32	2.32	3.31	9.4 (3.5 - 11.6)	1.780 (0.580 - 3.210)	7.82	99
22+35+42+42	1.5	2.3	2.8	2.8	9.4 (3.4 - 11.6)	1.780 (0.560 - 3.200)	7.82	99
25+25+25+25	2.35	2.35	2.35	2.35	9.4 (3.4 - 11.6)	1.950 (0.590 - 3.390)	8.56	99
25+25+25+35	2.14	2.14	2.14	2.98	9.4 (3.4 - 11.6)	1.910 (0.590 - 3.350)	8.39	99
25+25+25+42	2.01	2.01	2.01	3.37	9.4 (3.5 - 11.6)	1.880 (0.580 - 3.280)	8.26	99
25+25+25+50	1.88	1.88	1.88	3.76	9.4 (3.5 - 11.6)	1.860 (0.580 - 3.210)	8.17	99
25+25+25+60	1.74	1.74	1.74	4.18	9.4 (3.5 - 11.6)	1.860 (0.580 - 3.210)	8.17	99
25+25+35+35	1.96	1.96	2.74	2.74	9.4 (3.4 - 11.6)	1.870 (0.590 - 3.300)	8.21	99
25+25+35+42	1.85	1.85	2.59	3.11	9.4 (3.5 - 11.6)	1.820 (0.580 - 3.240)	7.99	99
25+25+35+50	1.74	1.74	2.44	3.48	9.4 (3.5 - 11.6)	1.780 (0.580 - 3.190)	7.82	99
25+35+35+35	1.81	2.53	2.53	2.53	9.4 (3.4 - 11.6)	1.840 (0.590 - 3.260)	8.08	99
25+35+35+42	1.72	2.40	2.40	2.88	9.4 (3.5 - 11.6)	1.790 (0.580 - 3.200)	7.86	99
35+35+35+35	2.35	2.35	2.35	2.35	9.4 (3.4 - 11.6)	1.930 (0.590 - 3.230)	8.48	99

MXZ-5A100VA

NOTE: Electrical data is for outdoor unit only.

Indoor units combination	Cooling capacity (kW)						Outdoor unit power consumption (kW)	Current (A)	Power factor (%)
	Unit A	Unit B	Unit C	Unit D	Unit E	Total			
22	2.20	-	-	-	-	2.2 (1.4 - 3.0)	0.680 (0.400 - 0.920)	2.99	99
25	2.50	-	-	-	-	2.5 (1.4 - 3.3)	0.760 (0.400 - 1.010)	3.34	99
35	3.50	-	-	-	-	3.5 (1.5 - 4.3)	1.030 (0.400 - 1.290)	4.52	99
42	4.20	-	-	-	-	4.2 (1.6 - 5.0)	1.230 (0.410 - 1.460)	5.40	99
50	5.00	-	-	-	-	5.0 (1.6 - 5.6)	1.440 (0.420 - 1.630)	6.32	99
60	6.00	-	-	-	-	6.0 (0.6 - 6.6)	1.930 (0.400 - 2.130)	8.48	99
71	7.10	-	-	-	-	7.1 (1.7 - 7.4)	2.580 (0.410 - 2.710)	11.33	99
22+22	2.20	2.20	-	-	-	4.4 (2.0 - 5.4)	1.130 (0.600 - 1.600)	4.96	99
22+25	2.20	2.50	-	-	-	4.7 (2.0 - 5.8)	1.270 (0.600 - 1.770)	5.58	99
22+35	2.20	3.50	-	-	-	5.7 (2.0 - 6.6)	1.710 (0.600 - 2.200)	7.51	99
22+42	2.20	4.20	-	-	-	6.4 (2.0 - 7.2)	2.080 (0.580 - 2.450)	9.13	99
22+50	2.20	5.00	-	-	-	7.2 (2.0 - 7.7)	2.450 (0.560 - 2.710)	10.76	99
22+60	2.09	5.71	-	-	-	7.8 (2.0 - 8.0)	2.750 (0.560 - 3.050)	12.08	99
22+71	1.87	6.03	-	-	-	7.9 (2.0 - 8.2)	2.810 (0.560 - 3.200)	12.34	99
25+25	2.50	2.50	-	-	-	5.0 (2.0 - 6.2)	1.360 (0.580 - 1.950)	5.97	99
25+35	2.50	3.50	-	-	-	6.0 (2.0 - 7.1)	2.010 (0.540 - 2.540)	8.83	99
25+42	2.50	4.20	-	-	-	6.7 (2.0 - 7.8)	2.290 (0.550 - 2.870)	10.06	99
25+50	2.50	5.00	-	-	-	7.5 (2.0 - 8.5)	2.580 (0.560 - 3.200)	11.33	99
25+60	2.29	5.51	-	-	-	7.8 (2.0 - 8.6)	2.750 (0.560 - 3.280)	12.08	99
25+71	2.06	5.84	-	-	-	7.9 (2.0 - 8.7)	2.810 (0.560 - 3.320)	12.34	99
35+35	3.50	3.50	-	-	-	7.0 (2.0 - 7.1)	2.400 (0.540 - 2.550)	10.54	99
35+42	3.36	4.04	-	-	-	7.4 (2.0 - 8.0)	2.580 (0.550 - 2.910)	11.33	99
35+50	3.21	4.59	-	-	-	7.8 (2.0 - 8.8)	2.760 (0.560 - 3.280)	12.12	99
35+60	2.91	4.99	-	-	-	7.9 (2.0 - 8.8)	2.730 (0.560 - 3.280)	11.99	99
35+71	2.74	5.56	-	-	-	8.3 (2.0 - 8.8)	3.050 (0.560 - 3.280)	13.39	99
42+42	3.90	3.90	-	-	-	7.8 (2.0 - 8.8)	2.760 (0.560 - 3.280)	12.12	99



Indoor units combination	Cooling capacity (kW)						Outdoor unit power consumption (kW)	Current (A)	Power factor (%)
	Unit A	Unit B	Unit C	Unit D	Unit E	Total			
42+50	3.61	4.29	-	-	-	7.9 (2.0 - 8.8)	2.740 (0.560 - 3.280)	12.03	99
42+60	3.34	4.76	-	-	-	8.1 (2.0 - 8.8)	2.890 (0.560 - 3.280)	12.69	99
42+71	3.20	5.40	-	-	-	8.6 (2.1 - 9.1)	3.170 (0.550 - 3.440)	13.92	99
50+50	4.15	4.15	-	-	-	8.3 (2.1 - 9.1)	3.050 (0.590 - 3.480)	13.39	99
50+60	3.91	4.69	-	-	-	8.6 (2.1 - 9.2)	3.250 (0.570 - 3.600)	14.27	99
50+71	3.68	5.22	-	-	-	8.9 (2.1 - 9.3)	3.300 (0.550 - 3.600)	14.49	99
60+60	4.45	4.45	-	-	-	8.9 (2.1 - 9.3)	3.300 (0.550 - 3.600)	14.49	99
60+71	4.17	4.93	-	-	-	9.1 (2.1 - 9.4)	3.450 (0.550 - 3.700)	15.15	99
71+71	4.55	4.55	-	-	-	9.1 (2.1 - 9.5)	3.400 (0.550 - 3.700)	14.93	99
22+22+22	2.20	2.20	2.20	-	-	6.6 (2.9 - 8.1)	1.860 (0.690 - 2.410)	8.17	99
22+22+25	2.20	2.20	2.50	-	-	6.9 (2.9 - 8.3)	1.970 (0.670 - 2.510)	8.65	99
22+22+35	2.14	2.14	3.42	-	-	7.7 (2.9 - 9.0)	2.310 (0.690 - 2.970)	10.14	99
22+22+42	1.99	1.99	3.82	-	-	7.8 (2.9 - 9.0)	2.310 (0.690 - 2.940)	10.14	99
22+22+50	1.85	1.85	4.20	-	-	7.9 (2.9 - 9.0)	2.320 (0.700 - 2.920)	10.19	99
22+22+60	1.82	1.82	4.96	-	-	8.6 (2.9 - 9.4)	2.650 (0.680 - 3.000)	11.64	99
22+22+71	1.65	1.65	5.30	-	-	8.6 (2.9 - 9.4)	2.680 (0.680 - 3.000)	11.77	99
22+25+25	2.20	2.50	2.50	-	-	7.2 (2.9 - 8.9)	2.100 (0.690 - 2.940)	9.22	99
22+25+35	2.09	2.38	3.33	-	-	7.8 (2.9 - 9.0)	2.350 (0.690 - 2.970)	10.32	99
22+25+42	2.03	2.30	3.87	-	-	8.2 (2.9 - 9.2)	2.500 (0.690 - 3.000)	10.98	99
22+25+50	1.93	2.19	4.38	-	-	8.5 (2.9 - 9.4)	2.650 (0.700 - 3.040)	11.64	99
22+25+60	1.77	2.01	4.82	-	-	8.6 (2.9 - 9.4)	2.680 (0.680 - 3.000)	11.77	99
22+25+71	1.62	1.84	5.24	-	-	8.7 (2.9 - 9.4)	2.680 (0.680 - 3.000)	11.77	99
22+35+35	1.88	3.01	3.01	-	-	7.9 (2.9 - 9.0)	2.350 (0.690 - 2.920)	10.32	99
22+35+42	1.82	2.90	3.48	-	-	8.2 (2.9 - 9.2)	2.470 (0.690 - 2.960)	10.85	99
22+35+50	1.75	2.78	3.97	-	-	8.5 (2.9 - 9.4)	2.600 (0.700 - 3.010)	11.42	99
22+35+60	1.64	2.60	4.46	-	-	8.7 (2.9 - 9.4)	2.630 (0.680 - 2.970)	11.55	99



Indoor units combination	Cooling capacity (kW)						Outdoor unit power consumption (kW)	Current (A)	Power factor (%)
	Unit A	Unit B	Unit C	Unit D	Unit E	Total			
22+35+71	1.58	2.52	5.10	-	-	9.2 (2.9 - 9.8)	2.810 (0.680 - 3.120)	12.34	99
22+42+42	1.70	3.25	3.25	-	-	8.2 (2.9 - 9.4)	2.600 (0.700 - 3.010)	11.42	99
22+42+50	1.66	3.17	3.77	-	-	8.6 (2.9 - 9.4)	2.610 (0.690 - 2.990)	11.46	99
22+42+60	1.60	3.05	4.35	-	-	9.0 (2.9 - 9.6)	2.720 (0.680 - 3.040)	11.95	99
22+42+71	1.50	2.86	4.84	-	-	9.2 (2.9 - 9.9)	2.890 (0.670 - 3.140)	12.69	99
22+50+50	1.62	3.69	3.69	-	-	9.0 (2.9 - 9.8)	2.690 (0.680 - 3.170)	11.81	99
22+50+60	1.53	3.48	4.19	-	-	9.2 (2.9 - 9.9)	2.800 (0.660 - 3.140)	12.30	99
22+50+71	1.41	3.22	4.57	-	-	9.2 (2.9 - 10.0)	2.970 (0.660 - 3.170)	13.04	99
22+60+60	1.42	3.89	3.89	-	-	9.2 (2.9 - 10.0)	2.970 (0.660 - 3.170)	13.04	99
22+60+71	1.33	3.65	4.32	-	-	9.3 (2.9 - 10.5)	3.000 (0.600 - 3.340)	13.18	99
25+25+25	2.50	2.50	2.50	-	-	7.5 (2.9 - 9.0)	2.250 (0.690 - 3.010)	9.88	99
25+25+35	2.29	2.29	3.22	-	-	7.8 (2.9 - 9.0)	2.350 (0.690 - 2.970)	10.32	99
25+25+42	2.23	2.23	3.74	-	-	8.2 (2.9 - 9.2)	2.500 (0.690 - 3.000)	10.98	99
25+25+50	2.13	2.13	4.24	-	-	8.5 (2.9 - 9.4)	2.650 (0.700 - 3.040)	11.64	99
25+25+60	1.95	1.95	4.70	-	-	8.6 (2.9 - 9.4)	2.680 (0.680 - 3.000)	11.77	99
25+25+71	1.86	1.86	5.28	-	-	9.0 (2.9 - 9.8)	2.680 (0.680 - 3.170)	11.77	99
25+35+35	2.08	2.91	2.91	-	-	7.9 (2.9 - 9.0)	2.350 (0.690 - 2.920)	10.32	99
25+35+42	2.03	2.85	3.42	-	-	8.3 (2.9 - 9.2)	2.510 (0.690 - 2.960)	11.02	99
25+35+50	1.95	2.74	3.91	-	-	8.6 (2.9 - 9.4)	2.670 (0.700 - 3.010)	11.73	99
25+35+60	1.87	2.63	4.50	-	-	9.0 (2.9 - 9.8)	2.690 (0.680 - 3.120)	11.81	99
25+35+71	1.75	2.46	4.99	-	-	9.2 (2.9 - 9.9)	2.820 (0.680 - 3.140)	12.38	99
25+42+42	1.98	3.31	3.31	-	-	8.6 (2.9 - 9.4)	2.670 (0.700 - 3.010)	11.73	99
25+42+50	1.88	3.16	3.76	-	-	8.8 (2.9 - 9.6)	2.680 (0.690 - 3.060)	11.77	99
25+42+60	1.79	3.01	4.30	-	-	9.1 (2.9 - 9.9)	2.750 (0.680 - 3.130)	12.08	99
25+42+71	1.67	2.80	4.73	-	-	9.2 (2.9 - 10.0)	2.770 (0.670 - 3.150)	12.17	99
25+50+50	1.84	3.68	3.68	-	-	9.2 (2.9 - 9.9)	2.820 (0.660 - 3.140)	12.38	99



Indoor units combination	Cooling capacity (kW)					Outdoor unit power consumption (kW)	Current (A)	Power factor (%)	
	Unit A	Unit B	Unit C	Unit D	Unit E				Total
25+50+60	1.70	3.41	4.09	-	-	9.2 (2.9 - 9.9)	2.800 (0.660 - 3.140)	12.30	99
25+50+71	1.58	3.15	4.47	-	-	9.2 (2.9 - 10.0)	2.730 (0.660 - 3.170)	11.99	99
25+60+60	1.58	3.81	3.81	-	-	9.2 (2.9 - 10.0)	2.730 (0.660 - 3.170)	11.99	99
25+60+71	1.51	3.62	4.27	-	-	9.4 (2.9 - 10.5)	2.800 (0.660 - 3.330)	12.30	99
35+35+35	2.87	2.87	2.87	-	-	8.6 (2.9 - 9.4)	2.550 (0.720 - 3.030)	11.20	99
35+35+42	2.70	2.70	3.40	-	-	8.8 (2.9 - 9.6)	2.620 (0.710 - 3.070)	11.51	99
35+35+50	2.63	2.63	3.74	-	-	9.0 (2.9 - 9.8)	2.690 (0.700 - 3.120)	11.81	99
35+35+60	2.48	2.48	4.24	-	-	9.2 (2.9 - 9.9)	2.810 (0.680 - 3.140)	12.34	99
35+35+71	2.26	2.26	4.58	-	-	9.1 (2.9 - 10.0)	2.740 (0.680 - 3.170)	12.03	99
35+42+42	2.64	3.18	3.18	-	-	9.0 (2.9 - 9.8)	2.690 (0.700 - 3.120)	11.81	99
35+42+50	2.51	3.01	3.58	-	-	9.1 (2.9 - 9.9)	2.750 (0.690 - 3.130)	12.08	99
35+42+60	2.35	2.82	4.03	-	-	9.2 (2.9 - 10.0)	2.770 (0.680 - 3.150)	12.17	99
35+42+71	2.20	2.64	4.46	-	-	9.3 (2.9 - 10.3)	2.760 (0.670 - 3.250)	12.12	99
35+50+50	2.34	3.33	3.33	-	-	9.0 (2.9 - 9.9)	2.720 (0.680 - 3.140)	11.95	99
35+50+60	2.22	3.17	3.81	-	-	9.2 (2.9 - 10.0)	2.730 (0.660 - 3.170)	11.99	99
35+50+71	2.11	3.01	4.28	-	-	9.4 (2.9 - 10.5)	2.790 (0.660 - 3.330)	12.25	99
35+60+60	2.12	3.64	3.64	-	-	9.4 (2.9 - 10.5)	2.790 (0.660 - 3.330)	12.25	99
35+60+71	2.00	3.43	4.07	-	-	9.5 (2.9 - 10.8)	2.780 (0.660 - 3.430)	12.21	99
42+42+42	3.00	3.00	3.00	-	-	9.0 (2.9 - 9.9)	2.750 (0.690 - 3.130)	12.08	99
42+42+50	2.88	2.88	3.44	-	-	9.2 (2.9 - 10.0)	2.760 (0.680 - 3.140)	12.12	99
42+42+60	2.71	2.71	3.88	-	-	9.3 (2.9 - 10.2)	2.760 (0.670 - 3.200)	12.12	99
42+42+71	2.54	2.54	4.32	-	-	9.4 (2.9 - 10.5)	2.790 (0.660 - 3.330)	12.25	99
42+50+50	2.76	3.27	3.27	-	-	9.3 (2.9 - 10.2)	2.760 (0.670 - 3.200)	12.12	99
42+50+60	2.60	3.09	3.71	-	-	9.4 (2.9 - 10.5)	2.760 (0.660 - 3.310)	12.12	99
42+50+71	2.45	2.91	4.14	-	-	9.5 (2.9 - 10.8)	2.810 (0.660 - 3.400)	12.34	99
42+60+60	2.46	3.52	3.52	-	-	9.5 (2.9 - 10.8)	2.810 (0.660 - 3.400)	12.34	99



Indoor units combination	Cooling capacity (kW)						Outdoor unit power consumption (kW)	Current (A)	Power factor (%)
	Unit A	Unit B	Unit C	Unit D	Unit E	Total			
50+50+50	3.13	3.13	3.13	-	-	9.4 (2.9 - 10.8)	2.790 (0.660 - 3.430)	12.25	99
50+50+60	2.97	2.97	3.56	-	-	9.5 (2.9 - 10.9)	2.790 (0.660 - 3.450)	12.25	99
50+50+71	2.81	2.81	3.98	-	-	9.6 (2.9 - 11.0)	2.830 (0.660 - 3.480)	12.43	99
22+22+22+22	1.95	1.95	1.95	1.95	-	7.8 (3.7 - 9.2)	2.180 (0.810 - 2.670)	9.57	99
22+22+22+25	1.91	1.91	1.91	2.17	-	7.9 (3.7 - 9.2)	2.190 (0.810 - 2.670)	9.62	99
22+22+22+35	1.76	1.76	1.76	2.82	-	8.1 (3.7 - 9.4)	2.280 (0.810 - 2.730)	10.01	99
22+22+22+42	1.71	1.71	1.71	3.27	-	8.4 (3.7 - 9.7)	2.340 (0.800 - 2.830)	10.28	99
22+22+22+50	1.63	1.63	1.63	3.71	-	8.6 (3.7 - 9.9)	2.410 (0.790 - 2.930)	10.58	99
22+22+22+60	1.57	1.57	1.57	4.29	-	9.0 (3.7 - 10.1)	2.510 (0.770 - 3.000)	11.02	99
22+22+22+71	1.48	1.48	1.48	4.76	-	9.2 (3.7 - 10.1)	2.570 (0.770 - 2.980)	11.29	99
22+22+25+25	1.87	1.87	2.13	2.13	-	8.0 (3.7 - 9.4)	2.260 (0.810 - 2.750)	9.93	99
22+22+25+35	1.82	1.82	2.07	2.89	-	8.6 (3.7 - 9.9)	2.480 (0.810 - 2.970)	10.89	99
22+22+25+42	1.74	1.74	1.98	3.34	-	8.8 (3.7 - 10.1)	2.470 (0.800 - 2.990)	10.85	99
22+22+25+50	1.65	1.65	1.87	3.73	-	8.9 (3.7 - 10.2)	2.460 (0.790 - 3.020)	10.80	99
22+22+25+60	1.53	1.53	1.74	4.20	-	9.0 (3.7 - 10.1)	2.510 (0.770 - 2.950)	11.02	99
22+22+25+71	1.41	1.41	1.61	4.57	-	9.0 (3.7 - 10.0)	2.490 (0.770 - 2.920)	10.94	99
22+22+35+35	1.66	1.66	2.64	2.64	-	8.6 (3.7 - 9.9)	2.480 (0.810 - 2.930)	10.89	99
22+22+35+42	1.62	1.62	2.57	3.09	-	8.9 (3.7 - 10.1)	2.490 (0.800 - 2.940)	10.94	99
22+22+35+50	1.53	1.53	2.44	3.50	-	9.0 (3.7 - 10.1)	2.510 (0.790 - 2.950)	11.02	99
22+22+35+60	1.42	1.42	2.27	3.89	-	9.0 (3.7 - 10.0)	2.490 (0.770 - 2.920)	10.94	99
22+22+35+71	1.38	1.38	2.19	4.45	-	9.4 (3.7 - 10.5)	2.580 (0.770 - 3.060)	11.33	99
22+22+42+42	1.55	1.55	2.95	2.95	-	9.0 (3.7 - 10.1)	2.510 (0.790 - 2.950)	11.02	99
22+22+42+50	1.45	1.45	2.78	3.32	-	9.0 (3.7 - 10.1)	2.500 (0.780 - 2.930)	10.98	99
22+22+42+60	1.38	1.38	2.65	3.79	-	9.2 (3.7 - 10.3)	2.530 (0.770 - 2.990)	11.11	99
22+22+42+71	1.33	1.33	2.54	4.30	-	9.5 (3.7 - 10.5)	2.560 (0.770 - 3.040)	11.24	99
22+22+50+50	1.48	1.48	3.37	3.37	-	9.7 (3.7 - 10.9)	2.740 (0.770 - 3.250)	12.03	99



Indoor units combination	Cooling capacity (kW)						Outdoor unit power consumption (kW)	Current (A)	Power factor (%)
	Unit A	Unit B	Unit C	Unit D	Unit E	Total			
22+22+50+60	1.34	1.34	3.05	3.67	-	9.4 (3.7 - 10.5)	2.580 (0.770 - 3.060)	11.33	99
22+22+50+71	1.28	1.28	2.91	4.13	-	9.6 (3.7 - 10.5)	2.550 (0.770 - 3.030)	11.20	99
22+25+25+25	1.83	2.09	2.09	2.09	-	8.1 (3.7 - 9.4)	2.200 (0.810 - 2.750)	9.66	99
22+25+25+35	1.77	2.01	2.01	2.81	-	8.6 (3.7 - 9.9)	2.480 (0.810 - 2.970)	10.89	99
22+25+25+42	1.67	1.91	1.91	3.21	-	8.7 (3.7 - 10.1)	2.450 (0.800 - 2.960)	10.76	99
22+25+25+50	1.59	1.80	1.80	3.61	-	8.8 (3.7 - 10.1)	2.430 (0.790 - 2.950)	10.67	99
22+25+25+60	1.50	1.70	1.70	4.10	-	9.0 (3.7 - 10.2)	2.510 (0.770 - 3.000)	11.02	99
22+25+25+71	1.45	1.64	1.64	4.67	-	9.4 (3.7 - 10.5)	2.580 (0.770 - 3.060)	11.33	99
22+25+35+35	1.67	1.90	2.66	2.66	-	8.9 (3.7 - 10.2)	2.460 (0.810 - 3.020)	10.80	99
22+25+35+42	1.60	1.81	2.54	3.05	-	9.0 (3.7 - 10.2)	2.480 (0.810 - 3.010)	10.89	99
22+25+35+50	1.50	1.70	2.39	3.41	-	9.0 (3.7 - 10.2)	2.510 (0.810 - 3.000)	11.02	99
22+25+35+60	1.46	1.65	2.32	3.97	-	9.4 (3.7 - 10.5)	2.600 (0.770 - 3.060)	11.42	99
22+25+35+71	1.35	1.54	2.15	4.36	-	9.4 (3.7 - 10.6)	2.580 (0.770 - 3.100)	11.33	99
22+25+42+42	1.51	1.71	2.89	2.89	-	9.0 (3.7 - 10.2)	2.510 (0.810 - 3.000)	11.02	99
22+25+42+50	1.46	1.65	2.78	3.31	-	9.2 (3.7 - 10.4)	2.550 (0.790 - 3.030)	11.20	99
22+25+42+60	1.39	1.57	2.65	3.79	-	9.4 (3.7 - 10.6)	2.590 (0.770 - 3.080)	11.37	99
22+25+42+71	1.31	1.48	2.49	4.22	-	9.5 (3.7 - 10.8)	2.550 (0.770 - 3.130)	11.20	99
22+25+50+50	1.40	1.60	3.20	3.20	-	9.4 (3.7 - 10.5)	2.600 (0.770 - 3.060)	11.42	99
22+25+50+60	1.32	1.50	2.99	3.59	-	9.4 (3.7 - 11.0)	2.580 (0.770 - 3.210)	11.33	99
22+25+50+71	1.25	1.43	2.86	4.06	-	9.6 (3.7 - 11.0)	2.530 (0.770 - 3.170)	11.11	99
22+35+35+35	1.58	2.54	2.54	2.54	-	9.2 (3.7 - 10.3)	2.580 (0.810 - 3.040)	11.33	99
22+35+35+42	1.53	2.43	2.43	2.91	-	9.3 (3.7 - 10.2)	2.590 (0.800 - 2.980)	11.37	99
22+35+35+50	1.45	2.32	2.32	3.31	-	9.4 (3.7 - 10.0)	2.600 (0.790 - 2.920)	11.42	99
22+35+35+60	1.36	2.16	2.16	3.72	-	9.4 (3.7 - 10.5)	2.580 (0.770 - 3.060)	11.33	99
22+35+35+71	1.30	2.06	2.06	4.18	-	9.6 (3.7 - 10.9)	2.560 (0.770 - 3.170)	11.24	99
22+35+42+42	1.47	2.33	2.80	2.80	-	9.4 (3.7 - 10.0)	2.600 (0.790 - 2.920)	11.42	99



Indoor units combination	Cooling capacity (kW)						Outdoor unit power consumption (kW)	Current (A)	Power factor (%)
	Unit A	Unit B	Unit C	Unit D	Unit E	Total			
22+35+42+50	1.39	2.21	2.65	3.15	-	9.4 (3.7 - 10.3)	2.600 (0.800 - 3.000)	11.42	99
22+35+42+60	1.32	2.09	2.51	3.58	-	9.5 (3.7 - 10.7)	2.600 (0.800 - 3.200)	11.42	99
22+35+42+71	1.24	1.98	2.37	4.01	-	9.6 (3.7 - 11.0)	2.530 (0.770 - 3.170)	11.11	99
22+35+50+50	1.34	2.14	3.06	3.06	-	9.6 (3.7 - 10.9)	2.540 (0.770 - 3.170)	11.16	99
22+35+50+60	1.26	2.01	2.87	3.44	-	9.6 (3.7 - 11.0)	2.530 (0.770 - 3.170)	11.11	99
22+42+42+42	1.39	2.67	2.67	2.67	-	9.4 (3.7 - 10.3)	2.600 (0.800 - 3.000)	11.42	99
22+42+42+50	1.34	2.56	2.56	3.04	-	9.5 (3.7 - 10.7)	2.600 (0.800 - 3.200)	11.42	99
22+42+42+60	1.27	2.43	2.43	3.47	-	9.6 (3.7 - 11.0)	2.530 (0.770 - 3.170)	11.11	99
22+42+50+50	1.29	2.45	2.93	2.93	-	9.6 (3.7 - 11.0)	2.530 (0.770 - 3.170)	11.11	99
25+25+25+25	2.15	2.15	2.15	2.15	-	8.6 (3.7 - 9.9)	2.410 (0.810 - 2.990)	10.58	99
25+25+25+35	1.95	1.95	1.95	2.75	-	8.6 (3.7 - 9.9)	2.490 (0.810 - 2.970)	10.94	99
25+25+25+42	1.90	1.90	1.90	3.20	-	8.9 (3.7 - 10.1)	2.500 (0.800 - 2.960)	10.98	99
25+25+25+50	1.80	1.80	1.80	3.60	-	9.0 (3.7 - 10.1)	2.510 (0.790 - 2.950)	11.02	99
25+25+25+60	1.69	1.69	1.69	4.03	-	9.1 (3.7 - 10.2)	2.530 (0.770 - 3.000)	11.11	99
25+25+25+71	1.61	1.61	1.61	4.57	-	9.4 (3.7 - 10.5)	2.580 (0.770 - 3.060)	11.33	99
25+25+35+35	1.83	1.83	2.57	2.57	-	8.8 (3.7 - 10.1)	2.430 (0.810 - 2.950)	10.67	99
25+25+35+42	1.79	1.79	2.51	3.01	-	9.1 (3.7 - 10.2)	2.530 (0.800 - 2.970)	11.11	99
25+25+35+50	1.70	1.70	2.39	3.41	-	9.2 (3.7 - 10.2)	2.640 (0.790 - 3.000)	11.59	99
25+25+35+60	1.62	1.62	2.27	3.89	-	9.4 (3.7 - 10.5)	2.600 (0.770 - 3.060)	11.42	99
25+25+35+71	1.54	1.54	2.15	4.37	-	9.6 (3.7 - 11.0)	2.650 (0.770 - 3.210)	11.64	99
25+25+42+42	1.72	1.72	2.88	2.88	-	9.2 (3.7 - 10.2)	2.640 (0.790 - 3.000)	11.59	99
25+25+42+50	1.64	1.64	2.75	3.27	-	9.3 (3.7 - 10.4)	2.600 (0.800 - 3.100)	11.42	99
25+25+42+60	1.56	1.56	2.63	3.75	-	9.5 (3.7 - 10.8)	2.700 (0.800 - 3.200)	11.86	99
25+25+42+71	1.47	1.47	2.46	4.20	-	9.6 (3.7 - 11.0)	2.560 (0.770 - 3.170)	11.24	99
25+25+50+50	1.57	1.57	3.13	3.13	-	9.4 (3.7 - 10.5)	2.550 (0.770 - 3.060)	11.20	99
25+25+50+60	1.50	1.50	3.00	3.60	-	9.6 (3.7 - 11.0)	2.560 (0.770 - 3.170)	11.24	99



Indoor units combination	Cooling capacity (kW)						Outdoor unit power consumption (kW)	Current (A)	Power factor (%)
	Unit A	Unit B	Unit C	Unit D	Unit E	Total			
25+25+50+71	1.43	1.43	2.87	4.07	-	9.8 (3.7 - 11.0)	2.610 (0.770 - 3.170)	11.46	99
25+35+35+35	1.74	2.42	2.42	2.42	-	9.0 (3.7 - 10.2)	2.510 (0.810 - 2.840)	11.02	99
25+35+35+42	1.68	2.35	2.35	2.82	-	9.2 (3.7 - 10.4)	2.540 (0.800 - 2.950)	11.16	99
25+35+35+50	1.62	2.27	2.27	3.24	-	9.4 (3.7 - 10.5)	2.580 (0.790 - 3.060)	11.33	99
25+35+35+60	1.55	2.17	2.17	3.71	-	9.6 (3.7 - 10.5)	2.650 (0.790 - 3.060)	11.64	99
25+35+35+71	1.45	2.02	2.02	4.11	-	9.6 (3.7 - 10.9)	2.560 (0.770 - 3.170)	11.24	99
25+35+42+42	1.63	2.29	2.74	2.74	-	9.4 (3.7 - 10.5)	2.580 (0.790 - 3.060)	11.33	99
25+35+42+50	1.56	2.19	2.62	3.13	-	9.5 (3.7 - 10.5)	2.700 (0.800 - 3.100)	11.86	99
25+35+42+60	1.48	2.07	2.49	3.56	-	9.6 (3.7 - 10.7)	2.700 (0.800 - 3.200)	11.86	99
25+42+42+42	1.58	2.64	2.64	2.64	-	9.5 (3.7 - 10.5)	2.700 (0.800 - 3.100)	11.86	99
25+42+42+50	1.50	2.54	2.54	3.02	-	9.6 (3.7 - 10.7)	2.700 (0.800 - 3.200)	11.86	99
25+42+42+60	1.46	2.43	2.43	3.48	-	9.8 (3.7 - 11.0)	2.610 (0.770 - 3.170)	11.46	99
25+42+50+50	1.48	2.46	2.93	2.93	-	9.8 (3.7 - 11.0)	2.610 (0.770 - 3.170)	11.46	99
35+35+35+35	2.35	2.35	2.35	2.35	-	9.4 (3.7 - 10.5)	2.570 (0.810 - 3.100)	11.29	99
35+35+35+42	2.26	2.26	2.26	2.72	-	9.5 (3.7 - 10.8)	2.600 (0.790 - 3.150)	11.42	99
35+35+35+50	2.17	2.17	2.17	3.09	-	9.6 (3.7 - 11.0)	2.640 (0.770 - 3.210)	11.59	99
35+35+35+60	2.04	2.04	2.04	3.48	-	9.6 (3.7 - 10.9)	2.560 (0.770 - 3.170)	11.24	99
35+35+42+42	2.16	2.16	2.64	2.64	-	9.6 (3.7 - 11.0)	2.640 (0.770 - 3.210)	11.59	99
35+35+42+50	2.07	2.07	2.49	2.97	-	9.6 (3.7 - 11.0)	2.600 (0.800 - 3.200)	11.42	99
35+42+42+42	2.10	2.50	2.50	2.50	-	9.6 (3.7 - 11.0)	2.600 (0.800 - 3.200)	11.42	99
35+42+42+50	2.03	2.43	2.43	2.91	-	9.8 (3.7 - 11.0)	2.610 (0.770 - 3.170)	11.46	99
42+42+42+42	2.45	2.45	2.45	2.45	-	9.8 (3.7 - 11.0)	2.610 (0.770 - 3.170)	11.46	99
22+22+22+22+22	2.00	2.00	2.00	2.00	2.00	10.0 (3.9 - 11.0)	2.935 (0.780 - 3.500)	12.89	99
22+22+22+22+25	1.95	1.95	1.95	1.95	2.20	10.0 (3.9 - 11.0)	2.935 (0.780 - 3.500)	12.89	99
22+22+22+22+35	1.79	1.79	1.79	1.79	2.84	10.0 (3.9 - 11.0)	2.935 (0.780 - 3.500)	12.89	99
22+22+22+22+42	1.69	1.69	1.69	1.69	3.24	10.0 (3.9 - 11.0)	2.920 (0.780 - 3.490)	12.82	99



Indoor units combination	Cooling capacity (kW)						Outdoor unit power consumption (kW)	Current (A)	Power factor (%)
	Unit A	Unit B	Unit C	Unit D	Unit E	Total			
22+22+22+22+50	1.59	1.59	1.59	1.59	3.64	10.0 (3.9 - 11.0)	2.915 (0.790 - 3.490)	12.80	99
22+22+22+22+60	1.49	1.49	1.49	1.49	4.04	10.0 (3.9 - 11.0)	2.905 (0.800 - 3.480)	12.76	99
22+22+22+22+71	1.38	1.38	1.38	1.38	4.48	10.0 (3.9 - 11.0)	2.905 (0.800 - 3.480)	12.76	99
22+22+22+25+25	1.90	1.90	1.90	2.15	2.15	10.0 (3.9 - 11.0)	2.935 (0.780 - 3.500)	12.89	99
22+22+22+25+35	1.75	1.75	1.75	1.97	2.78	10.0 (3.9 - 11.0)	2.935 (0.780 - 3.500)	12.89	99
22+22+22+25+42	1.65	1.65	1.65	1.88	3.17	10.0 (3.9 - 11.0)	2.920 (0.780 - 3.490)	12.82	99
22+22+22+25+50	1.56	1.56	1.56	1.77	3.55	10.0 (3.9 - 11.0)	2.915 (0.790 - 3.490)	12.80	99
22+22+22+25+60	1.46	1.46	1.46	1.66	3.96	10.0 (3.9 - 11.0)	2.905 (0.800 - 3.480)	12.76	99
22+22+22+25+71	1.36	1.36	1.36	1.54	4.38	10.0 (3.9 - 11.0)	2.905 (0.800 - 3.480)	12.76	99
22+22+22+35+35	1.62	1.62	1.62	2.57	2.57	10.0 (3.9 - 11.0)	2.935 (0.780 - 3.500)	12.89	99
22+22+22+35+42	1.53	1.53	1.53	2.45	2.96	10.0 (3.9 - 11.0)	2.920 (0.780 - 3.490)	12.82	99
22+22+22+35+50	1.46	1.46	1.46	2.32	3.30	10.0 (3.9 - 11.0)	2.915 (0.790 - 3.490)	12.80	99
22+22+22+35+60	1.37	1.37	1.37	2.17	3.72	10.0 (3.9 - 11.0)	2.905 (0.800 - 3.480)	12.76	99
22+22+22+35+71	1.28	1.28	1.28	2.03	4.13	10.0 (3.9 - 11.0)	2.905 (0.780 - 3.500)	12.76	99
22+22+22+42+42	1.46	1.46	1.46	2.81	2.81	10.0 (3.9 - 11.0)	2.915 (0.790 - 3.490)	12.80	99
22+22+22+42+50	1.39	1.39	1.39	2.66	3.17	10.0 (3.9 - 11.0)	2.900 (0.800 - 3.500)	12.74	99
22+22+22+42+60	1.31	1.31	1.31	2.50	3.57	10.0 (3.9 - 11.0)	2.900 (0.800 - 3.500)	12.74	99
22+22+25+25+25	1.85	1.85	2.10	2.10	2.10	10.0 (3.9 - 11.0)	2.935 (0.780 - 3.500)	12.89	99
22+22+25+25+35	1.71	1.71	1.94	1.94	2.70	10.0 (3.9 - 11.0)	2.935 (0.780 - 3.500)	12.89	99
22+22+25+25+42	1.61	1.61	1.84	1.84	3.10	10.0 (3.9 - 11.0)	2.920 (0.780 - 3.490)	12.82	99
22+22+25+25+50	1.53	1.53	1.74	1.74	3.46	10.0 (3.9 - 11.0)	2.915 (0.790 - 3.490)	12.80	99
22+22+25+25+60	1.43	1.43	1.62	1.62	3.90	10.0 (3.9 - 11.0)	2.905 (0.800 - 3.480)	12.76	99
22+22+25+25+71	1.33	1.33	1.52	1.52	4.30	10.0 (3.9 - 11.0)	2.905 (0.780 - 3.500)	12.76	99
22+22+25+35+35	1.58	1.58	1.80	2.52	2.52	10.0 (3.9 - 11.0)	2.935 (0.780 - 3.500)	12.89	99
22+22+25+35+42	1.50	1.50	1.71	2.40	2.89	10.0 (3.9 - 11.0)	2.920 (0.780 - 3.490)	12.82	99
22+22+25+35+50	1.43	1.43	1.62	2.27	3.25	10.0 (3.9 - 11.0)	2.915 (0.790 - 3.490)	12.80	99



Indoor units combination	Cooling capacity (kW)						Outdoor unit power consumption (kW)	Current (A)	Power factor (%)
	Unit A	Unit B	Unit C	Unit D	Unit E	Total			
22+22+25+35+60	1.34	1.34	1.53	2.13	3.66	10.0 (3.9 - 11.0)	2.905 (0.780 - 3.500)	12.76	99
22+22+25+42+42	1.43	1.43	1.64	2.75	2.75	10.0 (3.9 - 11.0)	2.915 (0.790 - 3.490)	12.80	99
22+22+25+42+50	1.36	1.36	1.55	2.60	3.13	10.0 (3.9 - 11.0)	2.900 (0.800 - 3.500)	12.74	99
22+22+25+42+60	1.28	1.28	1.46	2.45	3.53	10.0 (3.9 - 11.0)	2.900 (0.800 - 3.500)	12.74	99
22+22+35+35+35	1.47	1.48	2.35	2.35	2.35	10.0 (3.9 - 11.0)	2.935 (0.780 - 3.500)	12.89	99
22+22+35+35+42	1.41	1.41	2.24	2.24	2.70	10.0 (3.9 - 11.0)	2.920 (0.780 - 3.500)	12.82	99
22+22+35+35+50	1.34	1.34	2.13	2.13	3.06	10.0 (3.9 - 11.0)	2.905 (0.780 - 3.500)	12.76	99
22+22+35+42+42	1.35	1.35	2.14	2.58	2.58	10.0 (3.9 - 11.0)	2.900 (0.800 - 3.500)	12.74	99
22+22+35+42+50	1.28	1.28	2.05	2.47	2.92	10.0 (3.9 - 11.0)	2.900 (0.800 - 3.500)	12.74	99
22+22+42+42+42	1.28	1.28	2.48	2.48	2.48	10.0 (3.9 - 11.0)	2.900 (0.800 - 3.500)	12.74	99
22+25+25+25+25	1.80	2.05	2.05	2.05	2.05	10.0 (3.9 - 11.0)	2.935 (0.780 - 3.500)	12.89	99
22+25+25+25+35	1.67	1.89	1.89	1.89	2.66	10.0 (3.9 - 11.0)	2.935 (0.780 - 3.500)	12.89	99
22+25+25+25+42	1.58	1.80	1.80	1.80	3.02	10.0 (3.9 - 11.0)	2.920 (0.780 - 3.490)	12.82	99
22+25+25+25+50	1.50	1.70	1.70	1.70	3.40	10.0 (3.9 - 11.0)	2.915 (0.790 - 3.490)	12.80	99
22+25+25+25+60	1.40	1.59	1.59	1.59	3.83	10.0 (3.9 - 11.0)	2.905 (0.800 - 3.480)	12.76	99
22+25+25+25+71	1.30	1.49	1.49	1.49	4.23	10.0 (3.9 - 11.0)	2.905 (0.780 - 3.500)	12.76	99
22+25+25+35+35	1.56	1.76	1.76	2.46	2.46	10.0 (3.9 - 11.0)	2.935 (0.780 - 3.500)	12.89	99
22+25+25+35+42	1.47	1.68	1.68	2.35	2.82	10.0 (3.9 - 11.0)	2.920 (0.780 - 3.490)	12.82	99
22+25+25+35+50	1.40	1.59	1.59	2.23	3.19	10.0 (3.9 - 11.0)	2.915 (0.790 - 3.490)	12.80	99
22+25+25+35+60	1.31	1.50	1.50	2.10	3.59	10.0 (3.9 - 11.0)	2.905 (0.780 - 3.500)	12.76	99
22+25+25+42+42	1.42	1.60	1.60	2.69	2.69	10.0 (3.9 - 11.0)	2.915 (0.790 - 3.490)	12.80	99
22+25+25+42+50	1.35	1.52	1.52	2.56	3.05	10.0 (3.9 - 11.0)	2.905 (0.780 - 3.500)	12.76	99
22+25+35+35+35	1.46	1.64	2.30	2.30	2.30	10.0 (3.9 - 11.0)	2.935 (0.780 - 3.500)	12.89	99
22+25+35+35+42	1.39	1.57	2.20	2.20	2.64	10.0 (3.9 - 11.0)	2.920 (0.780 - 3.500)	12.82	99
22+25+35+35+50	1.32	1.49	2.10	2.10	2.99	10.0 (3.9 - 11.0)	2.905 (0.780 - 3.500)	12.76	99
22+25+35+42+42	1.32	1.51	2.11	2.53	2.53	10.0 (3.9 - 11.0)	2.905 (0.780 - 3.500)	12.76	99



Indoor units combination	Cooling capacity (kW)						Outdoor unit power consumption (kW)	Current (A)	Power factor (%)
	Unit A	Unit B	Unit C	Unit D	Unit E	Total			
22+35+35+35+35	1.36	2.16	2.16	2.16	2.16	10.0 (3.9 - 11.0)	2.920 (0.780 - 3.500)	12.82	99
22+35+35+35+42	1.30	2.07	2.07	2.07	2.49	10.0 (3.9 - 11.0)	2.905 (0.780 - 3.500)	12.76	99
25+25+25+25+25	2.00	2.00	2.00	2.00	2.00	10.0 (3.9 - 11.0)	2.935 (0.780 - 3.500)	12.89	99
25+25+25+25+35	1.85	1.85	1.85	1.85	2.60	10.0 (3.9 - 11.0)	2.935 (0.780 - 3.500)	12.89	99
25+25+25+25+42	1.76	1.76	1.76	1.76	2.96	10.0 (3.9 - 11.0)	2.920 (0.780 - 3.490)	12.82	99
25+25+25+25+50	1.67	1.67	1.67	1.67	3.32	10.0 (3.9 - 11.0)	2.915 (0.790 - 3.490)	12.80	99
25+25+25+25+60	1.56	1.56	1.56	1.56	3.76	10.0 (3.9 - 11.0)	2.905 (0.780 - 3.500)	12.76	99
25+25+25+25+71	1.46	1.46	1.46	1.46	4.16	10.0 (3.9 - 11.0)	2.905 (0.780 - 3.500)	12.76	99
25+25+25+35+35	1.72	1.72	1.72	2.42	2.42	10.0 (3.9 - 11.0)	2.935 (0.780 - 3.500)	12.89	99
25+25+25+35+42	1.64	1.64	1.64	2.30	2.78	10.0 (3.9 - 11.0)	2.920 (0.780 - 3.500)	12.82	99
25+25+25+35+50	1.56	1.56	1.56	2.19	3.13	10.0 (3.9 - 11.0)	2.905 (0.780 - 3.500)	12.76	99
25+25+25+35+60	1.47	1.47	1.47	2.06	3.53	10.0 (3.9 - 11.0)	2.905 (0.780 - 3.500)	12.76	99
25+25+25+42+42	1.56	1.56	1.56	2.66	2.66	10.0 (3.9 - 11.0)	2.905 (0.780 - 3.500)	12.76	99
25+25+25+42+50	1.49	1.50	1.50	2.52	2.99	10.0 (3.9 - 11.0)	2.905 (0.780 - 3.500)	12.76	99
25+25+35+35+35	1.61	1.61	2.26	2.26	2.26	10.0 (3.9 - 11.0)	2.935 (0.780 - 3.500)	12.89	99
25+25+35+35+42	1.54	1.54	2.16	2.16	2.60	10.0 (3.9 - 11.0)	2.920 (0.780 - 3.490)	12.82	99
25+25+35+35+50	1.47	1.47	2.06	2.06	2.94	10.0 (3.9 - 11.0)	2.915 (0.790 - 3.490)	12.80	99
25+25+35+42+42	1.48	1.48	2.07	2.48	2.49	10.0 (3.9 - 11.0)	2.905 (0.780 - 3.500)	12.76	99



Indoor units combination	Heating capacity (kW)						Outdoor unit power consumption (kW)	Current (A)	Power factor (%)
	Unit A	Unit B	Unit C	Unit D	Unit E	Total			
22	3.30	-	-	-	-	3.3 (1.2 - 4.6)	1.050 (0.340 - 1.590)	4.61	99
25	3.60	-	-	-	-	3.6 (1.2 - 5.0)	1.110 (0.340 - 1.740)	4.87	99
35	4.00	-	-	-	-	4.0 (1.2 - 5.3)	1.210 (0.330 - 1.810)	5.31	99
42	5.40	-	-	-	-	5.4 (1.3 - 6.8)	1.740 (0.330 - 2.260)	7.64	99
50	7.20	-	-	-	-	7.2 (1.4 - 8.2)	2.270 (0.330 - 2.710)	9.97	99
60	7.90	-	-	-	-	7.9 (1.4 - 8.6)	2.700 (0.330 - 3.060)	11.86	99
71	8.60	-	-	-	-	8.6 (1.6 - 9.2)	3.220 (0.360 - 3.520)	14.14	99
22+22	3.30	3.30	-	-	-	6.6 (1.8 - 7.2)	2.020 (0.480 - 2.760)	8.87	99
22+25	3.23	3.67	-	-	-	6.9 (1.8 - 8.7)	2.120 (0.480 - 3.000)	9.31	99
22+35	2.82	4.48	-	-	-	7.3 (1.8 - 9.2)	2.130 (0.480 - 3.110)	9.35	99
22+42	2.78	5.32	-	-	-	8.1 (1.8 - 9.9)	2.300 (0.470 - 3.230)	10.10	99
22+50	2.72	6.18	-	-	-	8.9 (1.8 - 10.5)	2.470 (0.460 - 3.360)	10.85	99
22+60	2.68	7.32	-	-	-	10.0 (1.8 - 10.5)	2.900 (0.460 - 3.360)	12.74	99
22+71	2.37	7.63	-	-	-	10.0 (1.8 - 10.5)	2.900 (0.460 - 3.360)	12.74	99
25+25	3.60	3.60	-	-	-	7.2 (1.8 - 9.1)	2.170 (0.480 - 3.140)	9.53	99
25+35	3.17	4.43	-	-	-	7.6 (1.8 - 9.5)	2.210 (0.480 - 3.230)	9.71	99
25+42	3.10	5.20	-	-	-	8.3 (1.8 - 9.8)	2.360 (0.470 - 3.240)	10.36	99
25+50	3.00	6.00	-	-	-	9.0 (1.8 - 10.1)	2.520 (0.460 - 3.260)	11.07	99
25+60	3.09	7.41	-	-	-	10.5 (1.8 - 11.2)	3.390 (0.460 - 3.660)	14.89	99
25+71	2.73	7.77	-	-	-	10.5 (1.8 - 11.3)	3.390 (0.460 - 3.690)	14.89	99
35+35	4.00	4.00	-	-	-	8.0 (1.8 - 9.8)	2.370 (0.480 - 3.230)	10.41	99
35+42	4.23	5.07	-	-	-	9.3 (1.8 - 10.5)	2.770 (0.470 - 3.400)	12.17	99
35+50	4.32	6.18	-	-	-	10.5 (1.8 - 11.0)	3.180 (0.460 - 3.580)	13.97	99
35+60	3.87	6.63	-	-	-	10.5 (1.8 - 11.1)	3.180 (0.460 - 3.610)	13.97	99
35+71	3.50	7.10	-	-	-	10.6 (1.8 - 11.4)	3.210 (0.460 - 3.690)	14.10	99
42+42	5.25	5.25	-	-	-	10.5 (1.8 - 11.0)	3.180 (0.460 - 3.580)	13.97	99



Indoor units combination	Heating capacity (kW)						Outdoor unit power consumption (kW)	Current (A)	Power factor (%)
	Unit A	Unit B	Unit C	Unit D	Unit E	Total			
42+50	4.79	5.71	-	-	-	10.5 (1.8 - 11.1)	3.180 (0.460 - 3.590)	13.97	99
42+60	4.36	6.24	-	-	-	10.6 (1.8 - 11.3)	3.190 (0.460 - 3.650)	14.01	99
42+71	3.94	6.66	-	-	-	10.6 (1.9 - 11.7)	3.090 (0.450 - 3.780)	13.57	99
50+50	5.30	5.30	-	-	-	10.6 (1.9 - 11.9)	2.980 (0.440 - 3.770)	13.09	99
50+60	4.82	5.78	-	-	-	10.6 (1.9 - 11.9)	2.980 (0.440 - 3.770)	13.09	99
50+71	4.38	6.22	-	-	-	10.6 (1.9 - 12.0)	2.980 (0.440 - 3.870)	13.09	99
60+60	5.30	5.30	-	-	-	10.6 (1.9 - 12.0)	2.980 (0.440 - 3.870)	13.09	99
60+71	4.85	5.75	-	-	-	10.6 (1.9 - 12.1)	2.980 (0.440 - 3.910)	13.09	99
71+71	5.30	5.30	-	-	-	10.6 (1.9 - 12.2)	2.980 (0.440 - 3.960)	13.09	99
22+22+22	2.90	2.90	2.90	-	-	8.7 (2.6 - 10.6)	2.150 (0.530 - 3.060)	9.44	99
22+22+25	2.80	2.81	3.19	-	-	8.8 (2.6 - 11.1)	2.170 (0.530 - 3.330)	9.53	99
22+22+35	2.78	2.78	4.44	-	-	10.0 (2.6 - 12.6)	2.810 (0.530 - 3.710)	12.34	99
22+22+42	2.68	2.68	5.14	-	-	10.5 (2.6 - 12.6)	2.850 (0.520 - 3.530)	12.52	99
22+22+50	2.57	2.57	5.86	-	-	11.0 (2.6 - 12.6)	2.900 (0.510 - 3.350)	12.74	99
22+22+60	2.33	2.33	6.35	-	-	11.0 (2.6 - 12.6)	2.890 (0.510 - 3.340)	12.69	99
22+22+71	2.10	2.10	6.80	-	-	11.0 (2.6 - 12.6)	2.890 (0.510 - 3.340)	12.69	99
22+25+25	2.72	3.09	3.09	-	-	8.9 (2.6 - 12.6)	2.170 (0.530 - 3.420)	9.53	99
22+25+35	2.68	3.05	4.27	-	-	10.0 (2.6 - 12.6)	2.750 (0.530 - 3.700)	12.08	99
22+25+42	2.59	2.95	4.96	-	-	10.5 (2.6 - 12.6)	2.810 (0.520 - 3.520)	12.34	99
22+25+50	2.49	2.84	5.67	-	-	11.0 (2.6 - 12.6)	2.880 (0.510 - 3.340)	12.65	99
22+25+60	2.26	2.57	6.17	-	-	11.0 (2.6 - 12.6)	2.870 (0.510 - 3.330)	12.60	99
22+25+71	2.05	2.33	6.62	-	-	11.0 (2.6 - 12.6)	2.870 (0.510 - 3.330)	12.60	99
22+35+35	2.52	3.99	3.99	-	-	10.5 (2.6 - 12.6)	2.970 (0.530 - 3.700)	13.04	99
22+35+42	2.40	3.82	4.58	-	-	10.8 (2.7 - 12.6)	2.920 (0.520 - 3.510)	12.82	99
22+35+50	2.26	3.60	5.14	-	-	11.0 (2.7 - 12.6)	2.870 (0.510 - 3.330)	12.60	99
22+35+60	2.07	3.29	5.64	-	-	11.0 (2.7 - 12.6)	2.860 (0.510 - 3.320)	12.56	99

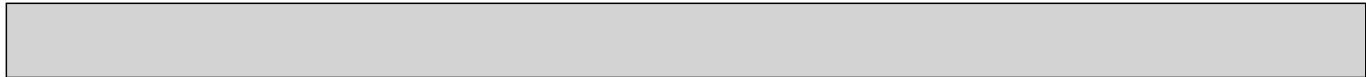

Indoor units combination	Heating capacity (kW)						Outdoor unit power consumption (kW)	Current (A)	Power factor (%)
	Unit A	Unit B	Unit C	Unit D	Unit E	Total			
22+35+71	1.89	3.01	6.10	-	-	11.0 (2.7 - 12.6)	2.860 (0.510 - 3.320)	12.56	99
22+42+42	2.28	4.36	4.36	-	-	11.0 (2.7 - 12.6)	2.870 (0.510 - 3.330)	12.60	99
22+42+50	2.12	4.06	4.82	-	-	11.0 (2.7 - 12.6)	2.860 (0.510 - 3.320)	12.56	99
22+42+60	1.95	3.73	5.32	-	-	11.0 (2.7 - 12.6)	2.860 (0.510 - 3.320)	12.56	99
22+42+71	1.79	3.42	5.79	-	-	11.0 (2.7 - 12.6)	2.780 (0.500 - 3.350)	12.21	99
22+50+50	1.98	4.51	4.51	-	-	11.0 (2.7 - 12.6)	2.720 (0.490 - 3.270)	11.95	99
22+50+60	1.83	4.17	5.00	-	-	11.0 (2.7 - 12.6)	2.710 (0.490 - 3.390)	11.90	99
22+50+71	1.69	3.85	5.46	-	-	11.0 (2.7 - 12.6)	2.710 (0.490 - 3.380)	11.90	99
22+60+60	1.70	4.65	4.65	-	-	11.0 (2.7 - 12.6)	2.710 (0.490 - 3.380)	11.90	99
22+60+71	1.58	4.31	5.11	-	-	11.0 (2.7 - 12.6)	2.710 (0.490 - 3.380)	11.90	99
25+25+25	3.00	3.00	3.00	-	-	9.0 (2.6 - 12.6)	2.170 (0.530 - 3.750)	9.53	99
25+25+35	2.97	2.97	4.16	-	-	10.1 (2.6 - 12.6)	2.480 (0.530 - 3.750)	10.89	99
25+25+42	2.88	2.88	4.84	-	-	10.6 (2.6 - 12.6)	2.670 (0.520 - 3.600)	11.73	99
25+25+50	2.75	2.75	5.50	-	-	11.0 (2.6 - 12.6)	2.870 (0.510 - 3.450)	12.60	99
25+25+60	2.50	2.50	6.00	-	-	11.0 (2.6 - 12.6)	2.860 (0.510 - 3.440)	12.56	99
25+25+71	2.27	2.27	6.46	-	-	11.0 (2.6 - 12.6)	2.860 (0.510 - 3.440)	12.56	99
25+35+35	2.76	3.87	3.87	-	-	10.5 (2.6 - 12.6)	2.890 (0.530 - 3.700)	12.69	99
25+35+42	2.65	3.70	4.45	-	-	10.8 (2.7 - 12.6)	2.720 (0.520 - 3.570)	11.95	99
25+35+50	2.50	3.50	5.00	-	-	11.0 (2.7 - 12.6)	2.550 (0.510 - 3.440)	11.20	99
25+35+60	2.29	3.21	5.50	-	-	11.0 (2.7 - 12.6)	2.860 (0.510 - 3.430)	12.56	99
25+35+71	2.10	2.94	5.96	-	-	11.0 (2.7 - 12.6)	2.850 (0.510 - 3.260)	12.52	99
25+42+42	2.52	4.24	4.24	-	-	11.0 (2.7 - 12.6)	2.550 (0.510 - 3.440)	11.20	99
25+42+50	2.35	3.95	4.70	-	-	11.0 (2.7 - 12.6)	2.700 (0.510 - 3.430)	11.86	99
25+42+60	2.16	3.64	5.20	-	-	11.0 (2.7 - 12.6)	2.850 (0.510 - 3.340)	12.52	99
25+42+71	1.99	3.35	5.66	-	-	11.0 (2.7 - 12.6)	2.770 (0.500 - 3.250)	12.17	99
25+50+50	2.20	4.40	4.40	-	-	11.0 (2.7 - 12.6)	2.700 (0.490 - 3.260)	11.86	99



Indoor units combination	Heating capacity (kW)						Outdoor unit power consumption (kW)	Current (A)	Power factor (%)
	Unit A	Unit B	Unit C	Unit D	Unit E	Total			
25+50+60	2.04	4.07	4.89	-	-	11.0 (2.7 - 12.6)	2.700 (0.490 - 3.380)	11.86	99
25+50+71	1.88	3.77	5.35	-	-	11.0 (2.7 - 12.6)	2.700 (0.490 - 3.250)	11.86	99
25+60+60	1.90	4.55	4.55	-	-	11.0 (2.7 - 12.6)	2.700 (0.490 - 3.250)	11.86	99
25+60+71	1.76	4.23	5.01	-	-	11.0 (2.7 - 12.6)	2.700 (0.490 - 3.250)	11.86	99
35+35+35	3.33	3.33	3.33	-	-	10.0 (2.6 - 12.6)	2.730 (0.530 - 3.700)	11.99	99
35+35+42	3.28	3.28	3.94	-	-	10.5 (2.7 - 12.6)	2.790 (0.520 - 3.560)	12.25	99
35+35+50	3.21	3.21	4.58	-	-	11.0 (2.7 - 12.6)	2.850 (0.510 - 3.430)	12.52	99
35+35+60	2.96	2.96	5.08	-	-	11.0 (2.7 - 12.6)	2.850 (0.510 - 3.430)	12.52	99
35+35+71	2.73	2.73	5.54	-	-	11.0 (2.7 - 12.6)	2.850 (0.510 - 3.430)	12.52	99
35+42+42	3.24	3.88	3.88	-	-	11.0 (2.7 - 12.6)	2.850 (0.510 - 3.430)	12.52	99
35+42+50	3.03	3.64	4.33	-	-	11.0 (2.7 - 12.6)	2.850 (0.510 - 3.430)	12.52	99
35+42+60	2.81	3.37	4.82	-	-	11.0 (2.7 - 12.6)	2.850 (0.510 - 3.430)	12.52	99
35+42+71	2.60	3.12	5.28	-	-	11.0 (2.7 - 12.6)	2.770 (0.500 - 3.340)	12.17	99
35+50+50	2.86	4.07	4.07	-	-	11.0 (2.7 - 12.6)	2.700 (0.490 - 3.250)	11.86	99
35+50+60	2.66	3.79	4.55	-	-	11.0 (2.7 - 12.6)	2.700 (0.490 - 3.250)	11.86	99
35+50+71	2.46	3.53	5.01	-	-	11.0 (2.7 - 12.6)	2.700 (0.490 - 3.250)	11.86	99
35+60+60	2.48	4.26	4.26	-	-	11.0 (2.7 - 12.6)	2.700 (0.490 - 3.250)	11.86	99
35+60+71	2.32	3.98	4.70	-	-	11.0 (2.7 - 12.6)	2.700 (0.490 - 3.250)	11.86	99
42+42+42	3.60	3.60	3.60	-	-	10.8 (2.7 - 12.6)	2.850 (0.510 - 3.430)	12.52	99
42+42+50	3.45	3.45	4.10	-	-	11.0 (2.7 - 12.6)	2.850 (0.510 - 3.430)	12.52	99
42+42+60	3.21	3.21	4.58	-	-	11.0 (2.7 - 12.6)	2.810 (0.500 - 3.380)	12.34	99
42+42+71	2.98	2.98	5.04	-	-	11.0 (2.7 - 12.6)	2.700 (0.490 - 3.250)	11.86	99
42+50+50	3.26	3.87	3.87	-	-	11.0 (2.7 - 12.6)	2.810 (0.500 - 3.380)	12.34	99
42+50+60	3.04	3.62	4.34	-	-	11.0 (2.7 - 12.6)	2.690 (0.490 - 3.240)	11.81	99
42+50+71	2.83	3.38	4.79	-	-	11.0 (2.7 - 12.6)	2.690 (0.490 - 3.240)	11.81	99
42+60+60	2.86	4.07	4.07	-	-	11.0 (2.7 - 12.6)	2.690 (0.490 - 3.240)	11.81	99



Indoor units combination	Heating capacity (kW)						Outdoor unit power consumption (kW)	Current (A)	Power factor (%)
	Unit A	Unit B	Unit C	Unit D	Unit E	Total			
50+50+50	3.67	3.67	3.67	-	-	11.0 (2.7 - 12.6)	2.700 (0.490 - 3.250)	11.86	99
50+50+60	3.43	3.44	4.13	-	-	11.0 (2.7 - 12.6)	2.690 (0.490 - 3.240)	11.81	99
50+50+71	3.22	3.22	4.56	-	-	11.0 (2.7 - 12.6)	2.690 (0.490 - 3.240)	11.81	99
22+22+22+22	2.50	2.50	2.50	2.50	-	10.0 (3.4 - 13.3)	2.180 (0.590 - 3.900)	9.57	99
22+22+22+25	2.42	2.42	2.42	2.74	-	10.0 (3.4 - 13.3)	2.170 (0.590 - 3.900)	9.53	99
22+22+22+35	2.29	2.29	2.29	3.64	-	10.5 (3.4 - 13.3)	2.290 (0.590 - 3.900)	10.06	99
22+22+22+42	2.20	2.20	2.20	4.20	-	10.8 (3.5 - 13.3)	2.340 (0.580 - 3.890)	10.28	99
22+22+22+50	2.09	2.09	2.09	4.73	-	11.0 (3.5 - 13.3)	2.390 (0.580 - 3.890)	10.50	99
22+22+22+60	1.92	1.92	1.92	5.24	-	11.0 (3.5 - 13.3)	2.380 (0.580 - 3.880)	10.45	99
22+22+22+71	1.77	1.77	1.77	5.69	-	11.0 (3.5 - 13.3)	2.380 (0.580 - 3.880)	10.45	99
22+22+25+25	2.34	2.34	2.66	2.66	-	10.0 (3.4 - 13.3)	2.160 (0.590 - 3.900)	9.49	99
22+22+25+35	2.22	2.22	2.52	3.54	-	10.5 (3.4 - 13.3)	2.280 (0.590 - 3.900)	10.01	99
22+22+25+42	2.14	2.14	2.43	4.09	-	10.8 (3.5 - 13.3)	2.330 (0.580 - 3.890)	10.23	99
22+22+25+50	2.03	2.03	2.31	4.63	-	11.0 (3.5 - 13.3)	2.380 (0.580 - 3.890)	10.45	99
22+22+25+60	1.88	1.88	2.13	5.11	-	11.0 (3.5 - 13.3)	2.370 (0.580 - 3.880)	10.41	99
22+22+25+71	1.73	1.73	1.96	5.58	-	11.0 (3.5 - 13.3)	2.370 (0.580 - 3.880)	10.41	99
22+22+35+35	2.03	2.03	3.22	3.22	-	10.5 (3.4 - 13.3)	2.280 (0.590 - 3.900)	10.01	99
22+22+35+42	1.96	1.96	3.12	3.76	-	10.8 (3.5 - 13.3)	2.320 (0.580 - 3.890)	10.19	99
22+22+35+50	1.88	1.88	2.98	4.26	-	11.0 (3.5 - 13.3)	2.370 (0.580 - 3.890)	10.41	99
22+22+35+60	1.74	1.74	2.77	4.75	-	11.0 (3.5 - 13.3)	2.360 (0.580 - 3.880)	10.36	99
22+22+35+71	1.61	1.61	2.57	5.21	-	11.0 (3.5 - 13.3)	2.360 (0.580 - 3.880)	10.36	99
22+22+42+42	1.89	1.89	3.61	3.61	-	11.0 (3.5 - 13.3)	2.370 (0.580 - 3.890)	10.41	99
22+22+42+50	1.78	1.78	3.40	4.04	-	11.0 (3.5 - 13.3)	2.360 (0.580 - 3.880)	10.36	99
22+22+42+60	1.66	1.66	3.16	4.52	-	11.0 (3.5 - 13.3)	2.360 (0.580 - 3.880)	10.36	99
22+22+42+71	1.54	1.54	2.94	4.98	-	11.0 (3.5 - 13.3)	2.310 (0.580 - 3.890)	10.14	99
22+22+50+50	1.68	1.68	3.82	3.82	-	11.0 (3.4 - 13.3)	2.270 (0.550 - 3.880)	9.97	99



Indoor units combination	Heating capacity (kW)						Outdoor unit power consumption (kW)	Current (A)	Power factor (%)
	Unit A	Unit B	Unit C	Unit D	Unit E	Total			
22+22+50+60	1.57	1.57	3.57	4.29	-	11.0 (3.5 - 13.3)	2.260 (0.580 - 3.870)	9.93	99
22+22+50+71	1.47	1.47	3.33	4.73	-	11.0 (3.5 - 13.3)	2.260 (0.580 - 3.900)	9.93	99
22+25+25+25	2.37	2.71	2.71	2.71	-	10.5 (3.4 - 13.3)	2.290 (0.590 - 3.900)	10.06	99
22+25+25+35	2.16	2.45	2.45	3.44	-	10.5 (3.4 - 13.3)	2.280 (0.590 - 3.900)	10.01	99
22+25+25+42	2.08	2.37	2.37	3.98	-	10.8 (3.5 - 13.3)	2.330 (0.580 - 3.890)	10.23	99
22+25+25+50	1.98	2.25	2.25	4.52	-	11.0 (3.5 - 13.3)	2.380 (0.580 - 3.890)	10.45	99
22+25+25+60	1.83	2.08	2.08	5.01	-	11.0 (3.5 - 13.3)	2.360 (0.580 - 3.880)	10.36	99
22+25+25+71	1.69	1.92	1.92	5.47	-	11.0 (3.5 - 13.3)	2.360 (0.580 - 3.880)	10.36	99
22+25+35+35	2.07	2.35	3.29	3.29	-	11.0 (3.4 - 13.3)	2.520 (0.590 - 3.900)	11.07	99
22+25+35+42	1.95	2.22	3.10	3.73	-	11.0 (3.5 - 13.3)	2.430 (0.580 - 3.890)	10.67	99
22+25+35+50	1.83	2.08	2.92	4.17	-	11.0 (3.5 - 13.3)	2.350 (0.580 - 3.890)	10.32	99
22+25+35+60	1.70	1.94	2.71	4.65	-	11.0 (3.5 - 13.3)	2.340 (0.580 - 3.880)	10.28	99
22+25+35+71	1.58	1.80	2.52	5.10	-	11.0 (3.5 - 13.3)	2.340 (0.580 - 3.880)	10.28	99
22+25+42+42	1.84	2.10	3.53	3.53	-	11.0 (3.5 - 13.3)	2.350 (0.580 - 3.890)	10.32	99
22+25+42+50	1.74	1.98	3.32	3.96	-	11.0 (3.5 - 13.3)	2.340 (0.580 - 3.880)	10.28	99
22+25+42+60	1.62	1.85	3.10	4.43	-	11.0 (3.5 - 13.3)	2.340 (0.580 - 3.880)	10.28	99
22+25+42+71	1.51	1.72	2.89	4.88	-	11.0 (3.5 - 13.3)	2.290 (0.580 - 3.890)	10.06	99
22+25+50+50	1.65	1.87	3.74	3.74	-	11.0 (3.5 - 13.3)	2.260 (0.580 - 3.880)	9.93	99
22+25+50+60	1.54	1.75	3.50	4.21	-	11.0 (3.5 - 13.3)	2.250 (0.580 - 3.870)	9.88	99
22+25+50+71	1.44	1.64	3.27	4.65	-	11.0 (3.5 - 13.3)	2.250 (0.580 - 3.900)	9.88	99
22+35+35+35	1.91	3.03	3.03	3.03	-	11.0 (3.4 - 13.3)	2.550 (0.590 - 3.900)	11.20	99
22+35+35+42	1.81	2.87	2.87	3.45	-	11.0 (3.5 - 13.3)	2.450 (0.580 - 3.890)	10.76	99
22+35+35+50	1.70	2.71	2.71	3.88	-	11.0 (3.5 - 13.3)	2.350 (0.580 - 3.890)	10.32	99
22+35+35+60	1.59	2.53	2.53	4.35	-	11.0 (3.5 - 13.3)	2.340 (0.580 - 3.880)	10.28	99
22+35+35+71	1.48	2.36	2.36	4.80	-	11.0 (3.5 - 13.3)	2.340 (0.580 - 3.900)	10.28	99
22+35+42+42	1.71	2.73	3.28	3.28	-	11.0 (3.5 - 13.3)	2.350 (0.580 - 3.890)	10.32	99



Indoor units combination	Heating capacity (kW)						Outdoor unit power consumption (kW)	Current (A)	Power factor (%)
	Unit A	Unit B	Unit C	Unit D	Unit E	Total			
22+35+42+50	1.61	2.59	3.10	3.69	-	11.0 (3.5 - 13.3)	2.400 (0.600 - 3.900)	10.54	99
22+35+42+60	1.52	2.42	2.91	4.15	-	11.0 (3.5 - 13.3)	2.300 (0.600 - 3.900)	10.10	99
22+35+42+71	1.42	2.27	2.72	4.59	-	11.0 (3.5 - 13.3)	2.250 (0.580 - 3.900)	9.88	99
22+35+50+50	1.54	2.45	3.50	3.51	-	11.0 (3.5 - 13.3)	2.240 (0.580 - 3.880)	9.84	99
22+35+50+60	1.45	2.31	3.29	3.95	-	11.0 (3.5 - 13.3)	2.250 (0.580 - 3.900)	9.88	99
22+42+42+42	7.88	3.12	3.12	3.12	-	17.2 (3.5 - 13.3)	2.400 (0.600 - 3.900)	10.54	99
22+42+42+50	1.55	2.96	2.96	3.53	-	11.0 (3.5 - 13.3)	2.300 (0.600 - 3.900)	10.10	99
22+42+42+60	1.46	2.79	2.79	3.96	-	11.0 (3.5 - 13.3)	2.250 (0.580 - 3.900)	9.88	99
22+42+50+50	1.48	2.82	3.35	3.35	-	11.0 (3.5 - 13.3)	2.250 (0.580 - 3.900)	9.88	99
25+25+25+25	2.50	2.50	2.50	2.50	-	10.0 (3.4 - 13.3)	2.160 (0.590 - 3.900)	9.49	99
25+25+25+35	2.27	2.27	2.27	3.19	-	10.0 (3.4 - 13.3)	2.150 (0.590 - 3.900)	9.44	99
25+25+25+42	2.24	2.24	2.24	3.78	-	10.5 (3.5 - 13.3)	2.250 (0.580 - 3.890)	9.88	99
25+25+25+50	2.20	2.20	2.20	4.40	-	11.0 (3.5 - 13.3)	2.360 (0.580 - 3.890)	10.36	99
25+25+25+60	2.04	2.04	2.04	4.88	-	11.0 (3.5 - 13.3)	2.350 (0.580 - 3.880)	10.32	99
25+25+25+71	1.88	1.88	1.88	5.36	-	11.0 (3.5 - 13.3)	2.350 (0.580 - 3.880)	10.32	99
25+25+35+35	2.29	2.29	3.21	3.21	-	11.0 (3.4 - 13.3)	2.550 (0.590 - 3.900)	11.20	99
25+25+35+42	2.16	2.16	3.03	3.65	-	11.0 (3.5 - 13.3)	2.440 (0.580 - 3.890)	10.72	99
25+25+35+50	2.04	2.04	2.85	4.07	-	11.0 (3.5 - 13.3)	2.330 (0.580 - 3.890)	10.23	99
25+25+35+60	1.90	1.90	2.66	4.54	-	11.0 (3.5 - 13.3)	2.300 (0.580 - 3.880)	10.10	99
25+25+35+71	1.76	1.76	2.47	5.01	-	11.0 (3.5 - 13.3)	2.300 (0.580 - 3.880)	10.10	99
25+25+42+42	2.05	2.05	3.45	3.45	-	11.0 (3.5 - 13.3)	2.330 (0.580 - 3.890)	10.23	99
25+25+42+50	1.93	1.93	3.25	3.88	-	11.0 (3.5 - 13.3)	2.300 (0.600 - 3.900)	10.10	99
25+25+42+60	1.81	1.81	3.04	4.34	-	11.0 (3.5 - 13.3)	2.300 (0.600 - 3.900)	10.10	99
25+25+42+71	1.68	1.68	2.83	4.80	-	11.0 (3.5 - 13.3)	2.240 (0.580 - 3.880)	9.84	99
25+25+50+50	1.83	1.83	3.67	3.67	-	11.0 (3.5 - 13.3)	2.250 (0.580 - 3.880)	9.88	99
25+25+50+60	1.72	1.72	3.44	4.12	-	11.0 (3.5 - 13.3)	2.240 (0.580 - 3.880)	9.84	99



Indoor units combination	Heating capacity (kW)						Outdoor unit power consumption (kW)	Current (A)	Power factor (%)
	Unit A	Unit B	Unit C	Unit D	Unit E	Total			
25+25+50+71	1.61	1.61	3.22	4.56	-	11.0 (3.5 - 13.3)	2.240 (0.580 - 3.880)	9.84	99
25+35+35+35	2.12	2.96	2.96	2.96	-	11.0 (3.4 - 13.3)	2.520 (0.590 - 3.900)	11.07	99
25+35+35+42	2.01	2.81	2.81	3.37	-	11.0 (3.5 - 13.3)	2.400 (0.580 - 3.890)	10.54	99
25+35+35+50	1.89	2.66	2.66	3.79	-	11.0 (3.5 - 13.3)	2.290 (0.580 - 3.890)	10.06	99
25+35+35+60	1.77	2.48	2.48	4.27	-	11.0 (3.5 - 13.3)	2.290 (0.580 - 3.880)	10.06	99
25+35+35+71	1.66	2.32	2.32	4.70	-	11.0 (3.5 - 13.3)	2.290 (0.580 - 3.900)	10.06	99
25+35+42+42	1.91	2.67	3.21	3.21	-	11.0 (3.5 - 13.3)	2.290 (0.580 - 3.890)	10.06	99
25+35+42+50	1.81	2.53	3.04	3.62	-	11.0 (3.5 - 13.3)	2.300 (0.600 - 3.900)	10.10	99
25+35+42+60	1.70	2.38	2.85	4.07	-	11.0 (3.5 - 13.3)	2.300 (0.600 - 3.900)	10.10	99
25+42+42+42	1.82	3.06	3.06	3.06	-	11.0 (3.5 - 13.3)	2.300 (0.600 - 3.900)	10.10	99
25+42+42+50	1.72	2.91	2.91	3.46	-	11.0 (3.5 - 13.3)	2.300 (0.600 - 3.900)	10.10	99
25+42+42+60	1.63	2.73	2.73	3.91	-	11.0 (3.5 - 13.3)	2.240 (0.580 - 3.880)	9.84	99
25+42+50+50	1.65	2.77	3.29	3.29	-	11.0 (3.5 - 13.3)	2.240 (0.580 - 3.880)	9.84	99
35+35+35+35	2.75	2.75	2.75	2.75	-	11.0 (3.4 - 13.3)	2.500 (0.590 - 3.900)	10.98	99
35+35+35+42	2.62	2.62	2.62	3.14	-	11.0 (3.5 - 13.3)	2.400 (0.580 - 3.890)	10.54	99
35+35+35+50	2.48	2.48	2.48	3.56	-	11.0 (3.5 - 13.3)	2.310 (0.580 - 3.890)	10.14	99
35+35+35+60	2.33	2.33	2.33	4.01	-	11.0 (3.5 - 13.3)	2.300 (0.590 - 3.880)	10.10	99
35+35+42+42	2.50	2.50	3.00	3.00	-	11.0 (3.5 - 13.3)	2.310 (0.580 - 3.890)	10.14	99
35+35+42+50	2.37	2.37	2.85	3.41	-	11.0 (3.5 - 13.3)	2.300 (0.600 - 3.900)	10.10	99
35+42+42+42	2.39	2.87	2.87	2.87	-	11.0 (3.5 - 13.3)	2.300 (0.600 - 3.900)	10.10	99
35+42+42+50	2.27	2.74	2.74	3.25	-	11.0 (3.5 - 13.3)	2.240 (0.580 - 3.880)	9.84	99
42+42+42+42	2.75	2.75	2.75	2.75	-	11.0 (3.5 - 13.3)	2.240 (0.580 - 3.880)	9.84	99
22+22+22+22+22	2.40	2.40	2.40	2.40	2.40	12.0 (4.1 - 14.0)	2.835 (0.780 - 4.100)	12.45	99
22+22+22+22+25	2.34	2.34	2.34	2.34	2.64	12.0 (4.1 - 14.0)	2.835 (0.780 - 4.100)	12.45	99
22+22+22+22+35	2.15	2.15	2.15	2.15	3.40	12.0 (4.1 - 14.0)	2.835 (0.780 - 4.100)	12.45	99
22+22+22+22+42	2.03	2.03	2.03	2.03	3.88	12.0 (4.1 - 14.0)	2.820 (0.780 - 4.090)	12.38	99



Indoor units combination	Heating capacity (kW)						Outdoor unit power consumption (kW)	Current (A)	Power factor (%)
	Unit A	Unit B	Unit C	Unit D	Unit E	Total			
22+22+22+22+50	1.91	1.91	1.91	1.91	4.36	12.0 (4.1 - 14.0)	2.815 (0.790 - 4.080)	12.36	99
22+22+22+22+60	1.78	1.78	1.78	1.78	4.88	12.0 (4.1 - 14.0)	2.805 (0.800 - 4.070)	12.32	99
22+22+22+22+71	1.66	1.66	1.66	1.66	5.36	12.0 (4.1 - 14.0)	2.805 (0.800 - 4.070)	12.32	99
22+22+22+25+25	2.28	2.28	2.28	2.58	2.58	12.0 (4.1 - 14.0)	2.835 (0.780 - 4.100)	12.45	99
22+22+22+25+35	2.10	2.10	2.10	2.38	3.32	12.0 (4.1 - 14.0)	2.835 (0.780 - 4.100)	12.45	99
22+22+22+25+42	1.98	1.98	1.98	2.26	3.80	12.0 (4.1 - 14.0)	2.820 (0.780 - 4.090)	12.38	99
22+22+22+25+50	1.87	1.87	1.87	2.13	4.26	12.0 (4.1 - 14.0)	2.815 (0.790 - 4.080)	12.36	99
22+22+22+25+60	1.75	1.75	1.75	1.99	4.76	12.0 (4.1 - 14.0)	2.805 (0.800 - 4.070)	12.32	99
22+22+22+25+71	1.63	1.63	1.63	1.85	5.26	12.0 (4.1 - 14.0)	2.805 (0.800 - 4.070)	12.32	99
22+22+22+35+35	1.94	1.94	1.94	3.09	3.09	12.0 (4.1 - 14.0)	2.835 (0.780 - 4.100)	12.45	99
22+22+22+35+42	1.84	1.84	1.84	2.94	3.54	12.0 (4.1 - 14.0)	2.820 (0.780 - 4.090)	12.38	99
22+22+22+35+50	1.75	1.75	1.75	2.78	3.97	12.0 (4.1 - 14.0)	2.815 (0.790 - 4.080)	12.36	99
22+22+22+35+60	1.64	1.64	1.64	2.61	4.47	12.0 (4.1 - 14.0)	2.805 (0.800 - 4.070)	12.32	99
22+22+22+35+71	1.53	1.53	1.53	2.44	4.97	12.0 (4.1 - 14.0)	2.805 (0.780 - 4.100)	12.32	99
22+22+22+42+42	1.76	1.76	1.76	3.36	3.36	12.0 (4.1 - 14.0)	2.815 (0.790 - 4.080)	12.36	99
22+22+22+42+50	1.67	1.67	1.67	3.19	3.80	12.0 (4.1 - 14.0)	2.800 (0.800 - 4.100)	12.30	99
22+22+22+42+60	1.57	1.57	1.57	3.00	4.29	12.0 (4.1 - 14.0)	2.800 (0.800 - 4.100)	12.30	99
22+22+25+25+25	2.22	2.22	2.52	2.52	2.52	12.0 (4.1 - 14.0)	2.835 (0.780 - 4.100)	12.45	99
22+22+25+25+35	2.04	2.04	2.33	2.33	3.26	12.0 (4.1 - 14.0)	2.835 (0.780 - 4.100)	12.45	99
22+22+25+25+42	1.94	1.94	2.20	2.20	3.72	12.0 (4.1 - 14.0)	2.820 (0.780 - 4.090)	12.38	99
22+22+25+25+50	1.83	1.83	2.08	2.08	4.18	12.0 (4.1 - 14.0)	2.815 (0.790 - 4.080)	12.36	99
22+22+25+25+60	1.71	1.71	1.95	1.95	4.68	12.0 (4.1 - 14.0)	2.805 (0.800 - 4.070)	12.32	99
22+22+25+25+71	1.60	1.60	1.82	1.82	5.16	12.0 (4.1 - 14.0)	2.805 (0.780 - 4.100)	12.32	99
22+22+25+35+35	1.90	1.90	2.16	3.02	3.02	12.0 (4.1 - 14.0)	2.835 (0.780 - 4.100)	12.45	99
22+22+25+35+42	1.81	1.81	2.05	2.88	3.45	12.0 (4.1 - 14.0)	2.820 (0.780 - 4.090)	12.38	99
22+22+25+35+50	1.71	1.71	1.95	2.73	3.90	12.0 (4.1 - 14.0)	2.815 (0.790 - 4.080)	12.36	99



Indoor units combination	Heating capacity (kW)					Total	Outdoor unit power consumption (kW)	Current (A)	Power factor (%)
	Unit A	Unit B	Unit C	Unit D	Unit E				
22+22+25+35+60	1.14	1.14	1.29	4.04	4.39	12.0 (4.1 - 14.0)	2.805 (0.780 - 4.100)	12.32	99
22+22+25+42+42	1.72	1.72	1.96	3.30	3.30	12.0 (4.1 - 14.0)	2.815 (0.790 - 4.080)	12.36	99
22+22+25+42+50	1.64	1.64	1.86	3.13	3.73	12.0 (4.1 - 14.0)	2.800 (0.800 - 4.100)	12.30	99
22+22+25+42+60	1.54	1.54	1.75	2.94	4.23	12.0 (4.1 - 14.0)	2.800 (0.800 - 4.100)	12.30	99
22+22+35+35+35	1.77	1.77	2.82	2.82	2.82	12.0 (4.1 - 14.0)	2.835 (0.780 - 4.100)	12.45	99
22+22+35+35+42	1.69	1.69	2.69	2.69	3.24	12.0 (4.1 - 14.0)	2.820 (0.780 - 4.100)	12.38	99
22+22+35+35+50	1.61	1.61	2.56	2.56	3.66	12.0 (4.1 - 14.0)	2.805 (0.780 - 4.100)	12.32	99
22+22+35+42+42	1.62	1.62	2.58	3.09	3.09	12.0 (4.1 - 14.0)	2.800 (0.800 - 4.100)	12.30	99
22+22+35+42+50	1.54	1.54	2.45	2.95	3.52	12.0 (4.1 - 14.0)	2.800 (0.800 - 4.100)	12.30	99
22+22+42+42+42	1.56	1.56	2.96	2.96	2.96	12.0 (4.1 - 14.0)	2.800 (0.800 - 4.100)	12.30	99
22+25+25+25+25	2.16	2.46	2.46	2.46	2.46	12.0 (4.1 - 14.0)	2.835 (0.780 - 4.100)	12.45	99
22+25+25+25+35	2.00	2.27	2.27	2.27	3.19	12.0 (4.1 - 14.0)	2.835 (0.780 - 4.100)	12.45	99
22+25+25+25+42	1.89	2.16	2.16	2.16	3.63	12.0 (4.1 - 14.0)	2.820 (0.780 - 4.090)	12.38	99
22+25+25+25+50	1.80	2.04	2.04	2.04	4.08	12.0 (4.1 - 14.0)	2.815 (0.790 - 4.080)	12.36	99
22+25+25+25+60	1.68	1.91	1.91	1.91	4.59	12.0 (4.1 - 14.0)	2.805 (0.800 - 4.070)	12.32	99
22+25+25+25+71	1.57	1.79	1.79	1.79	5.06	12.0 (4.1 - 14.0)	2.805 (0.780 - 4.100)	12.32	99
22+25+25+35+35	1.86	2.11	2.11	2.96	2.96	12.0 (4.1 - 14.0)	2.835 (0.780 - 4.100)	12.45	99
22+25+25+35+42	1.78	2.01	2.01	2.82	3.38	12.0 (4.1 - 14.0)	2.820 (0.780 - 4.090)	12.38	99
22+25+25+35+50	1.68	1.91	1.91	2.68	3.82	12.0 (4.1 - 14.0)	2.815 (0.790 - 4.080)	12.36	99
22+25+25+35+60	1.58	1.80	1.80	2.51	4.31	12.0 (4.1 - 14.0)	2.805 (0.780 - 4.100)	12.32	99
22+25+25+42+42	1.70	1.92	1.92	3.23	3.23	12.0 (4.1 - 14.0)	2.815 (0.790 - 4.080)	12.36	99
22+25+25+42+50	1.61	1.83	1.83	3.07	3.66	12.0 (4.1 - 14.0)	2.805 (0.780 - 4.100)	12.32	99
22+25+35+35+35	1.75	1.97	2.76	2.76	2.76	12.0 (4.1 - 14.0)	2.835 (0.780 - 4.100)	12.45	99
22+25+35+35+42	1.66	1.89	2.64	2.64	3.17	12.0 (4.1 - 14.0)	2.820 (0.780 - 4.100)	12.38	99
22+25+35+35+50	1.68	1.68	2.52	2.52	3.60	12.0 (4.1 - 14.0)	2.805 (0.780 - 4.100)	12.32	99
22+25+35+42+42	1.59	1.80	2.53	3.04	3.04	12.0 (4.1 - 14.0)	2.805 (0.780 - 4.100)	12.32	99



Indoor units combination	Heating capacity (kW)						Outdoor unit power consumption (kW)	Current (A)	Power factor (%)
	Unit A	Unit B	Unit C	Unit D	Unit E	Total			
22+35+35+35+35	1.64	2.59	2.59	2.59	2.59	12.0 (4.1 - 14.0)	2.820 (0.780 - 4.100)	12.38	99
22+35+35+35+42	1.55	2.49	2.49	2.49	2.98	12.0 (4.1 - 14.0)	2.805 (0.780 - 4.100)	12.32	99
25+25+25+25+25	2.40	2.40	2.40	2.40	2.40	12.0 (4.1 - 14.0)	2.835 (0.780 - 4.100)	12.45	99
25+25+25+25+35	2.22	2.22	2.22	2.22	3.12	12.0 (4.1 - 14.0)	2.835 (0.780 - 4.100)	12.45	99
25+25+25+25+42	2.11	2.11	2.11	2.11	3.56	12.0 (4.1 - 14.0)	2.820 (0.780 - 4.090)	12.38	99
25+25+25+25+50	2.00	2.00	2.00	2.00	4.00	12.0 (4.1 - 14.0)	2.815 (0.790 - 4.080)	12.36	99
25+25+25+25+60	1.88	1.88	1.88	1.88	4.48	12.0 (4.1 - 14.0)	2.805 (0.780 - 4.100)	12.32	99
25+25+25+25+71	1.75	1.75	1.75	1.75	5.00	12.0 (4.1 - 14.0)	2.805 (0.780 - 4.100)	12.32	99
25+25+25+35+35	2.07	2.07	2.07	2.90	2.90	12.0 (4.1 - 14.0)	2.835 (0.780 - 4.100)	12.45	99
25+25+25+35+42	1.97	1.97	1.97	2.76	3.33	12.0 (4.1 - 14.0)	2.820 (0.780 - 4.100)	12.38	99
25+25+25+35+50	1.87	1.87	1.87	2.63	3.76	12.0 (4.1 - 14.0)	2.805 (0.780 - 4.100)	12.32	99
25+25+25+35+60	1.76	1.76	1.76	2.47	4.25	12.0 (4.1 - 14.0)	2.805 (0.780 - 4.100)	12.32	99
25+25+25+42+42	1.88	1.88	1.88	3.18	3.18	12.0 (4.1 - 14.0)	2.805 (0.780 - 4.100)	12.32	99
25+25+25+42+50	1.79	1.79	1.79	3.03	3.60	12.0 (4.1 - 14.0)	2.805 (0.780 - 4.100)	12.32	99
25+25+35+35+35	1.94	1.94	2.71	2.71	2.71	12.0 (4.1 - 14.0)	2.835 (0.780 - 4.100)	12.45	99
25+25+35+35+42	1.85	1.85	2.59	2.59	3.12	12.0 (4.1 - 14.0)	2.820 (0.780 - 4.090)	12.38	99
25+25+35+35+50	1.76	1.76	2.47	2.47	3.54	12.0 (4.1 - 14.0)	2.815 (0.790 - 4.080)	12.36	99
25+25+35+42+42	1.77	1.77	2.50	2.98	2.98	12.0 (4.1 - 14.0)	2.805 (0.780 - 4.100)	12.32	99

5

SPECIFICATION

Outdoor model			MXZ-2A30VA		
Outdoor unit power supply			Single phase 230 V, 50 Hz		
System	Indoor units number		2		
	Piping total length	m	Max. 20		
	Connecting pipe length	m	Max. 15		
	Height difference (Indoor ~ Outdoor)	m	Refer to 9		
	Height difference (Indoor ~ Indoor)	m	Refer to 9		
Function			Cooling	Heating	
Capacity	Capacity [Rated (Min.-Max.) Hz]*1	kW	3.0 (1.1 - 4.0)		4.0 (1.0 - 4.5)
	Dehumidification	ℓ/h	—		—
	Outdoor air flow	m ³ /h	1,950		1,950
*2 Electrical data	Breaker capacity	A	10		
	Running current *1	A	2.87		3.6
	Power input	W	595		745
	Power factor *1	%	90		
	Starting current *1	A	3.60		
	Compressor motor current	A	2.67		3.40
	Fan motor current	A	0.2		
Coefficient of performance(C.O.P) *2			5.04		5.37
Compressor	Model		E1	KNB092FEDH	
			E2	KNB073FGDH	
	Output	W	750		
Fan motor	Winding resistance (at 20 °C)		Ω	U-V 1.70 V-W 1.70 W-U 1.70	
	Model		RC0J50-CF		
Fan motor	Winding resistance (at 20 °C)		Ω	BLK-WHT 14.2 WHT-RED 14.2 RED-BLK 14.2	
	Dimensions W x H x D		mm	800 x 550 x 285	
Weight		kg	34		
Special remarks	Sound level (High/Low) *3		dB	46/44	
	Fan speed (High/Low) *3		rpm	850/650	
	Fan speed regulator *3			2	
	Refrigerant filling capacity (R410A)		kg	1.15	
	Refrigeration oil (Model)		cc	320 (NEO22)	

NOTE: •Test conditions are based on ISO 5151. (Refrigerant piping length (one way): 5 m)

•Refer to 3 "INDOOR/OUTDOOR CORRESPONDENCE TABLE" for the combination.

*1 Measured under rated operating frequency.

*2 Electrical data is for only outdoor unit.

*3 These specifications are when all indoor units are operating.

TEST CONDITIONS COOLING INDOOR Dry-bulb temperature 27.0°C Wet-bulb temperature 19.0°C
 OUTDOOR Dry-bulb temperature 35.0°C Wet-bulb temperature 24.0°C
 HEATING INDOOR Dry-bulb temperature 20.0°C
 OUTDOOR Dry-bulb temperature 7.0°C Wet-bulb temperature 6.0°C



Outdoor model			MXZ-2A40VA - E1		MXZ-2A40VA - E2		
Outdoor unit power supply			Single phase 230 V, 50 Hz		Single phase 230 V, 50 Hz		
System	Indoor units number		2		2		
	Piping total length	m	Max. 30		Max. 30		
	Connecting pipe length	m	Max. 20		Max. 20		
	Height difference (Indoor ~ Outdoor)	m	Refer to 9		Refer to 9		
	Height difference (Indoor ~ Indoor)	m	Refer to 9		Refer to 9		
Function			Cooling	Heating	Cooling	Heating	
Capacity	Capacity [Rated (Min.-Max.) Hz]*1	kW	4.0 (1.1 - 4.5)	4.5 (1.0 - 5.0)	4.0 (1.1 - 4.5)	4.5 (1.0 - 5.0)	
	Dehumidification	ℓ/h	—		—		
	Outdoor air flow	m ³ /h	1,860	1,860	1,950	1,950	
*2 Electrical data	Breaker capacity	A	15		15		
	Running current *1	A	4.78	4.32	4.78	4.32	
	Power input	W	1,045	945	1,045	945	
	Power factor *1	%	95		95		
	Starting current *1	A	4.78		4.78		
	Compressor motor current	A	4.58	4.12	4.58	4.12	
	Fan motor current	A	0.2		0.2		
Coefficient of performance(C.O.P) *2			3.83	4.76	3.83	4.76	
Compressor	Model		SNB130FKCH		KNB092FEDH		
	Output	W	1,100		1,100		
	Winding resistance(at 20 °C)	Ω	U-V 0.64 V-W 0.64 W-U 0.64		U-V 1.70 V-W 1.70 W-U 1.70		
Fan motor	Model		RC0J50-CF		RC0J50-CF		
	Winding resistance(at 20 °C)	Ω	BLK-WHT 14.2 WHT-RED 14.2 RED-BLK 14.2		BLK-WHT 14.2 WHT-RED 14.2 RED-BLK 14.2		
Dimensions W x H x D		mm	800 x 550 x 285		800 x 550 x 285		
Weight		kg	40		34		
Special remarks	Sound level (High/Low) *3	dB	47/44	48/47	47/44	48/47	
	Fan speed (High/Low) *3	rpm	850/530	850/490	850/650	850/650	
	Fan speed regulator *3			2		2	
	Refrigerant filling capacity(R410A)	kg	1.3		1.15		
	Refrigeration oil (Model)	cc	450 (NEO22)		320 (NEO22)		

NOTE: •Test conditions are based on ISO 5151. (Refrigerant piping length (one way): 5 m)
 •Refer to 3 "INDOOR/OUTDOOR CORRESPONDENCE TABLE" for the combination.

*1 Measured under rated operating frequency.

*2 Electrical data is for only outdoor unit.

*3 These specifications are when all indoor units are operating.

TEST CONDITIONS COOLING INDOOR Dry-bulb temperature 27.0°C Wet-bulb temperature 19.0°C
 OUTDOOR Dry-bulb temperature 35.0°C Wet-bulb temperature 24.0°C
 HEATING INDOOR Dry-bulb temperature 20.0°C
 OUTDOOR Dry-bulb temperature 7.0°C Wet-bulb temperature 6.0°C



Outdoor model			MXZ-2A52VA		MXZ-3A54VA		
Outdoor unit power supply			Single phase 230 V, 50 Hz		Single phase 230 V, 50 Hz		
System	Indoor units number		2		2 to 3		
	Piping total length	m	Max. 30		Max. 50		
	Connecting pipe length	m	Max. 20		Max. 25		
	Height difference (Indoor ~ Outdoor)	m	Refer to 9		Refer to 9		
	Height difference (Indoor ~ Indoor)	m	Refer to 9		Refer to 9		
Function			Cooling	Heating	Cooling	Heating	
Capacity	Capacity [Rated (Min.-Max.) Hz]*1	kW	5.2 (1.1 - 6.0)	6.4 (1.0 - 7.2)	5.4 (2.9-6.8)	6.8 (2.6-9.0)	
	Dehumidification	ℓ/h	—	—	—	—	
	Outdoor air flow	m ³ /h	1,860	1,860	2,525	2,470	
*2 Electrical data	Breaker capacity	A	15		25		
	Running current *1	A	6.75	7.64	5.69	6.39	
	Power input	W	1,505	1,705	1,295	1,455	
	Power factor *1	%	97		99		
	Starting current *1	A	7.64		6.39		
	Compressor motor current	A	6.55	7.44	5.49	6.19	
	Fan motor current	A	0.2		0.2		
Coefficient of performance(C.O.P) *2			3.46	3.75	4.17	4.67	
Compressor	Model		E1	SNB130FKCH	E1 , E2	SNB130FLDH1	
					E3	SNB130FLEH1	
	Output	W	1,400		1,400		
		Winding resistance(at 20 °C)	Ω	U-V 0.64 V-W 0.64 W-U 0.64		E1 , E2 , E3	U-V 0.45 V-W 0.45 W-U 0.45
						E4 , E5 , E6 , E7	U-V 0.98 V-W 0.98 W-U 0.98
Model		RC0J50-CF		RC0J60-AA			
Fan motor	Winding resistance(at 20 °C)	Ω	BLK-WHT 14.2 WHT-RED 14.2 RED-BLK 14.2		BLK-WHT 15.2 WHT-RED 15.2 RED-BLK 15.2		
	Dimensions W x H x D	mm	800 x 550 x 285		840 x 710 x 330		
Weight	kg	40		57			
Special remarks	Sound level (High/Low) *3	dB	49/45	50/48	46/44	48/47	
	Fan speed (High/Low) *3	rpm	850/530	850/490	650/510	640/510	
	Fan speed regulator *3		2		2		
	Refrigerant filling capacity(R410A)	kg	1.3		2.7		
	Refrigeration oil (Model)	cc	450 (NEO22)		E1 , E2 , E3	600 (NEO22)	
				E4 , E5 , E6 , E7	700 (NEO22)		

NOTE: •Test conditions are based on ISO 5151. (Refrigerant piping length (one way): 5 m)
 •Refer to 3 "INDOOR/OUTDOOR CORRESPONDENCE TABLE" for the combination.

*1 Measured under rated operating frequency.

*2 Electrical data is for only outdoor unit.

*3 These specifications are when all indoor units are operating.

TEST CONDITIONS COOLING INDOOR Dry-bulb temperature 27.0°C Wet-bulb temperature 19.0°C
 OUTDOOR Dry-bulb temperature 35.0°C Wet-bulb temperature 24.0°C
 HEATING INDOOR Dry-bulb temperature 20.0°C
 OUTDOOR Dry-bulb temperature 7.0°C Wet-bulb temperature 6.0°C



Outdoor model			MXZ-4A71VA		MXZ-4A80VA	
Outdoor unit power supply			Single phase 230 V, 50 Hz		Single phase 230 V, 50 Hz	
System	Indoor units number		2 to 4		2 to 4	
	Piping total length	m	Max. 60		Max. 70	
	Connecting pipe length	m	Max. 25		Max. 25	
	Height difference (Indoor ~ Outdoor)	m	Refer to 9		Refer to 9	
	Height difference (Indoor ~ Indoor)	m	Refer to 9		Refer to 9	
Function			Cooling	Heating	Cooling	Heating
Capacity	Capacity [Rated (Min.-Max.) Hz]*1	kW	7.1 (3.7-8.8)	8.6 (3.4-9.0)	8.0 (3.7-9.2)	9.4 (3.4-11.6)
	Dehumidification	ℓ/h	—		—	
	Outdoor air flow	m ³ /h	2,525	2,790	2,530	2,630
*2 Electrical data	Breaker capacity	A	25		25	
	Running current *1	A	8.48	8.56	9.62	8.48
	Power input	W	1,930	1,950	2,190	1,930
	Power factor *1	%	99		99	
	Starting current *1	A	8.56		9.62	
	Compressor motor current	A	8.28	8.36	9.42	8.28
	Fan motor current	A	0.2		0.2	
Coefficient of performance(C.O.P) *2			3.68	4.41	3.65	4.87
Compressor	Model		[E1], [E2]	SNB130FLDH1	TNB220FMCH	
			[E3]	SNB130FLEH1		
			[E4], [E5], [E6]	SNB130FGBH1		
			[E7]	SNB130FGBH1T		
Output	W	2,000		2,100		
Winding resistance (at 20 °C)	Ω	[E1], [E2], [E3]	U-V 0.45 V-W 0.45 W-U 0.45		U-V 1.41 V-W 1.41 W-U 1.41	
		[E4], [E5], [E6], [E7]	U-V 0.98 V-W 0.98 W-U 0.98			
Fan motor	Model		RC0J60-AA		PM8H60-UA	
	Winding resistance (at 20°C)	Ω	BLK-WHT 15.2 WHT-RED 15.2 RED-BLK 15.2		BLK-WHT 15.2 WHT-RED 15.2 RED-BLK 15.2	
Dimensions W x H x D		mm	840 x 710 x 330		900 x 900 x 320	
Weight		kg	58		[E1] [E2]	70 67
Special remarks	Sound level (High/Low) *3	dB	48/45	50/48	46/44	48/46
	Fan speed (High/Low) *3	rpm	650/510	700/510	560/400	590/400
	Fan speed regulator *3		2		2	
	Refrigerant filling capacity (R410A)	kg	2.7		3.5	
	Refrigeration oil (Model)	cc	[E1], [E2], [E3]	600 (NEO22)		870 (NEO22)
[E4], [E5], [E6], [E7]			700 (NEO22)			

NOTE: •Test conditions are based on ISO 5151. (Refrigerant piping length (one way): 5 m)
 •Refer to 3 "INDOOR/OUTDOOR CORRESPONDENCE TABLE" for the combination.

*1 Measured under rated operating frequency.

*2 Electrical data is for only outdoor unit.

*3 These specifications are when all indoor units are operating.

TEST CONDITIONS COOLING INDOOR Dry-bulb temperature 27.0°C Wet-bulb temperature 19.0°C
 OUTDOOR Dry-bulb temperature 35.0°C Wet-bulb temperature 24.0°C
 HEATING INDOOR Dry-bulb temperature 20.0°C
 OUTDOOR Dry-bulb temperature 7.0°C Wet-bulb temperature 6.0°C

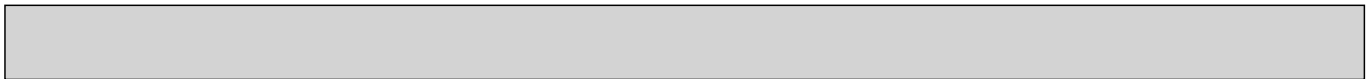

Outdoor model			MXZ-5A100VA	
Outdoor unit power supply			Single phase 230 V, 50 Hz	
System	Indoor units number		2 to 5	
	Piping total length	m	Max. 80	
	Connecting pipe length	m	Max. 25	
	Height difference (Indoor ~ Outdoor)	m	Refer to 9	
	Height difference (Indoor ~ Indoor)	m	Refer to 9	
Function			Cooling	Heating
Capacity	Capacity [Rated (Min.-Max.) Hz *1]	kW	10 (3.7 - 11)	12 (3.4 - 14)
	Dehumidification	ℓ/h	—	—
	Outdoor air flow	m ³ /h	3,396	3,558
*2 Electrical data	Breaker capacity	A	25	
	Running current *1	A	12.88	12.45
	Power input	W	2,935	2,835
	Power factor *1	%	99	
	Starting current *1	A	12.88	
	Compressor motor current	A	12.68	12.25
	Fan motor current	A	0.2	
Coefficient of performance(C.O.P) *2			3.41	4.23
Compressor	Model		TNB220FMCH	
	Output	W	2,700	
	Winding resistance(at 20 °C)	Ω	U-V 1.41 V-W 1.41 W-U 1.41	
Fan motor	Model		PM8H60-UA	
	Winding resistance(at 20 °C)	Ω	BLK-WHT 15.2 WHT-RED 15.2 RED-BLK 15.2	
Dimensions W x H x D		mm	900 x 900 x 320	
Weight		kg	68	
Special remarks	Sound level (High/Low) *3		51/45	54/46
	Fan speed (High/Low) *3		700/500	700/500
	Fan speed regulator *3		2	
	Refrigerant filling capacity(R410A)	kg	4.0	
	Refrigeration oil (Model)	cc	870 (NEO22)	

NOTE: •Test conditions are based on ISO 5151. (Refrigerant piping length (one way): 5 m)
 •Refer to 3 "INDOOR/OUTDOOR CORRESPONDENCE TABLE" for the combination.

*1 Measured under rated operating frequency.

*2 Electrical data is for only outdoor unit.

*3 These specifications are when all indoor units are operating.

TEST CONDITIONS COOLING INDOOR Dry-bulb temperature 27.0°C Wet-bulb temperature 19.0°C
 OUTDOOR Dry-bulb temperature 35.0°C Wet-bulb temperature 24.0°C
 HEATING INDOOR Dry-bulb temperature 20.0°C
 OUTDOOR Dry-bulb temperature 7.0°C Wet-bulb temperature 6.0°C

NOISE CRITERIA CURVES

MXZ-2A30VA

FAN SPEED	FUNCTION	SPL(dB(A))	LINE
High	Cooling	46	●—●
High	Heating	47	○—○

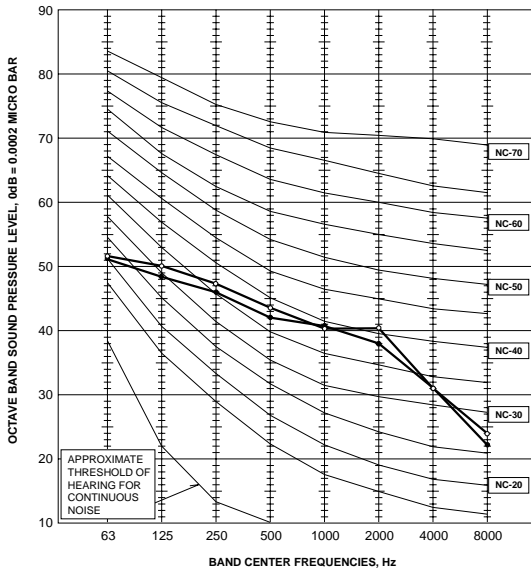

MXZ-2A40VA

FAN SPEED	FUNCTION	SPL(dB(A))	LINE
High	Cooling	47	●—●
High	Heating	48	○—○

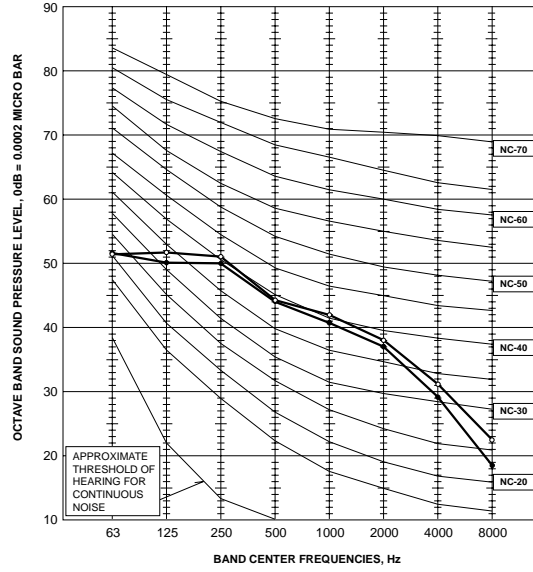

MXZ-2A52VA

FAN SPEED	FUNCTION	SPL(dB(A))	LINE
High	Cooling	49	●—●
High	Heating	50	○—○

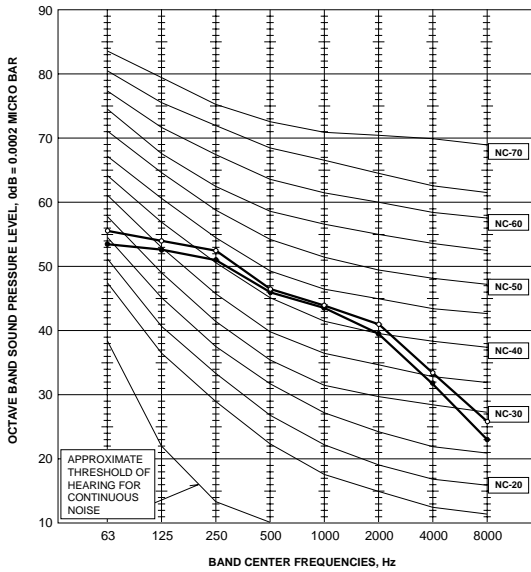

MXZ-3A54VA

FAN SPEED	FUNCTION	SPL(dB(A))	LINE
High	Cooling	46	●—●
High	Heating	48	○—○

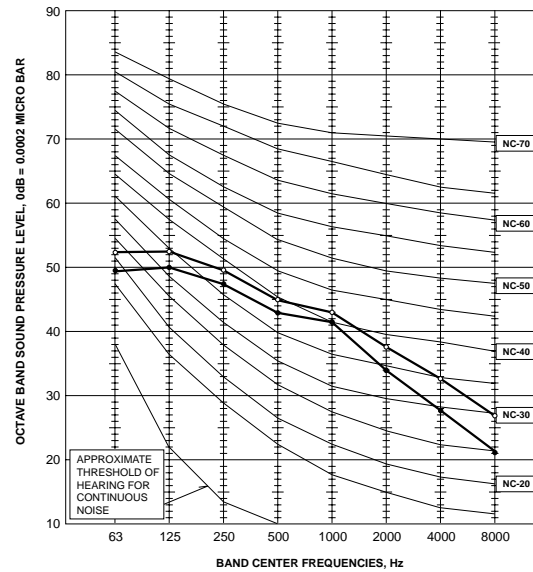

MXZ-4A71VA

FAN SPEED	FUNCTION	SPL(dB(A))	LINE
High	Cooling	48	●—●
High	Heating	50	○—○

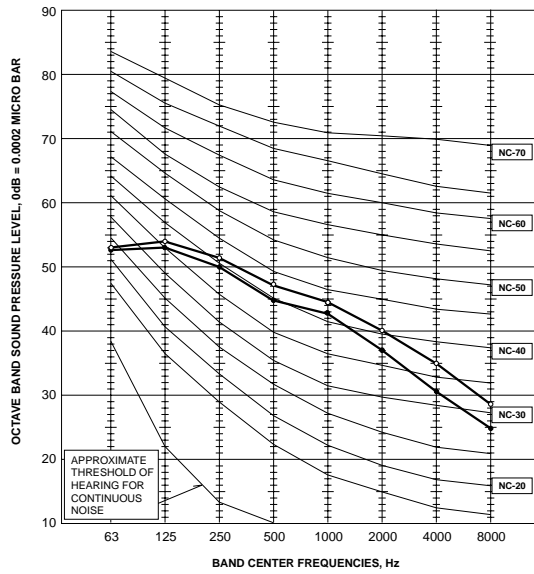

MXZ-4A80VA

FAN SPEED	FUNCTION	SPL(dB(A))	LINE
High	Cooling	46	●—●
High	Heating	48	○—○

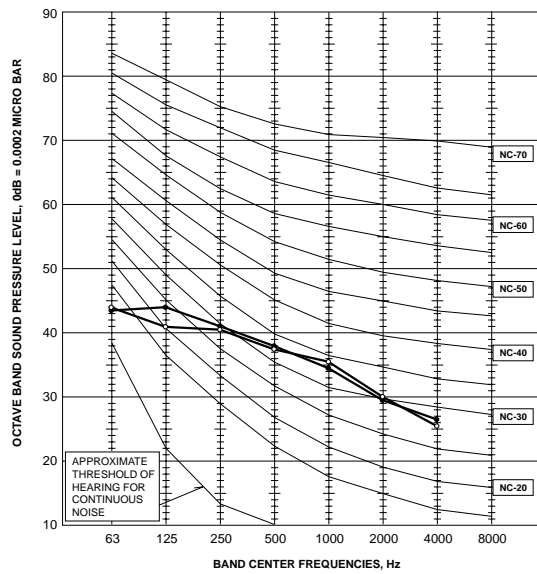

MXZ-5A100VA

FAN SPEED	FUNCTION	SPL(dB(A))	LINE
High	Cooling	51	●—●
High	Heating	54	○—○

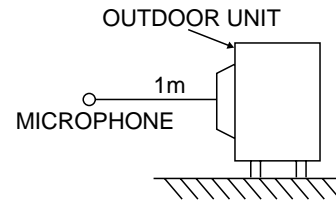
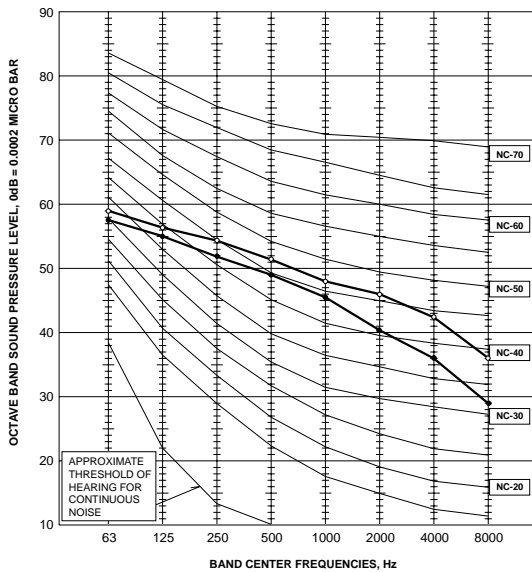

Test conditions

Cooling :Dry-bulb temperature 35°C Wet-bulb temperature 24°C
 Heating :Dry-bulb temperature 7°C Wet-bulb temperature 6°C

MXZ-2A30VA
MXZ-2A40VA
MXZ-2A52VA

Unit: mm

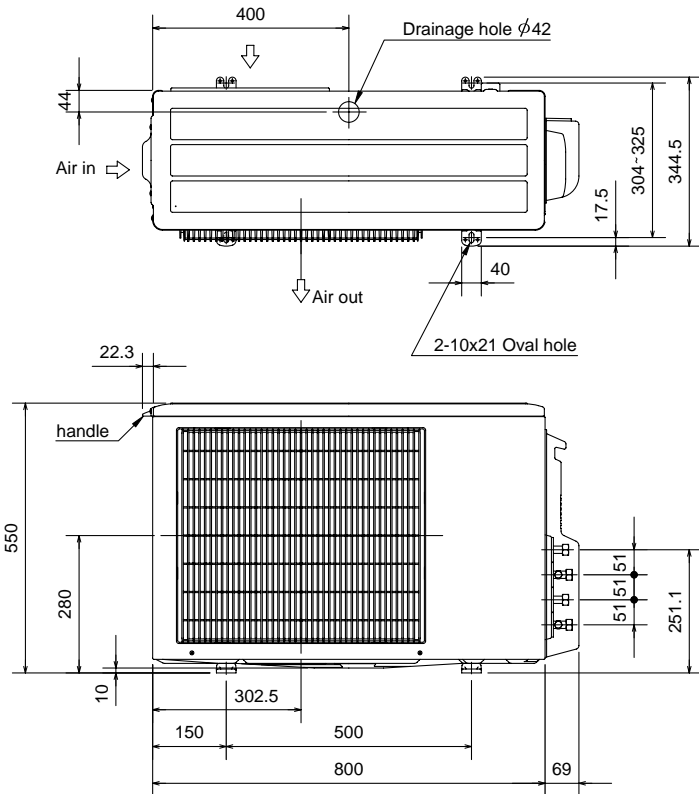

REQUIRED SPACE

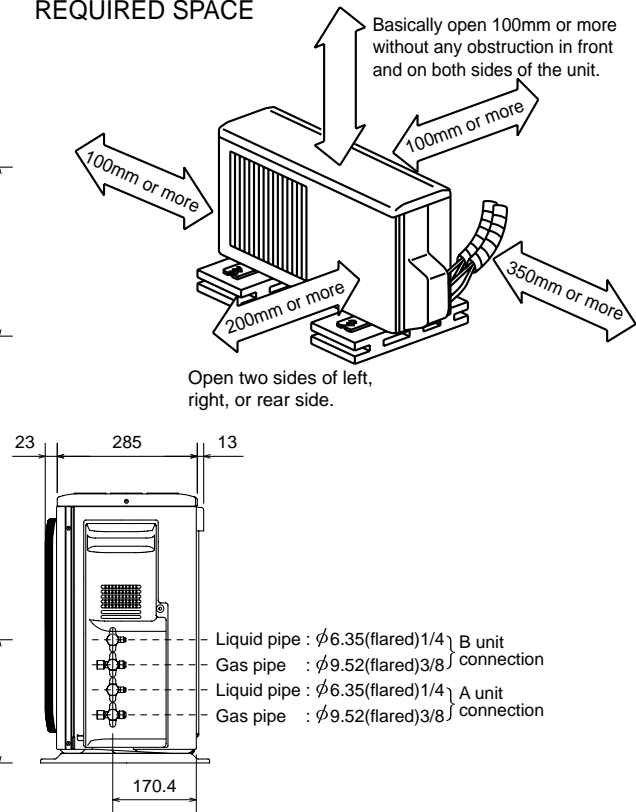

MXZ-3A54VA - E1, E2, E3, E4

Unit: mm

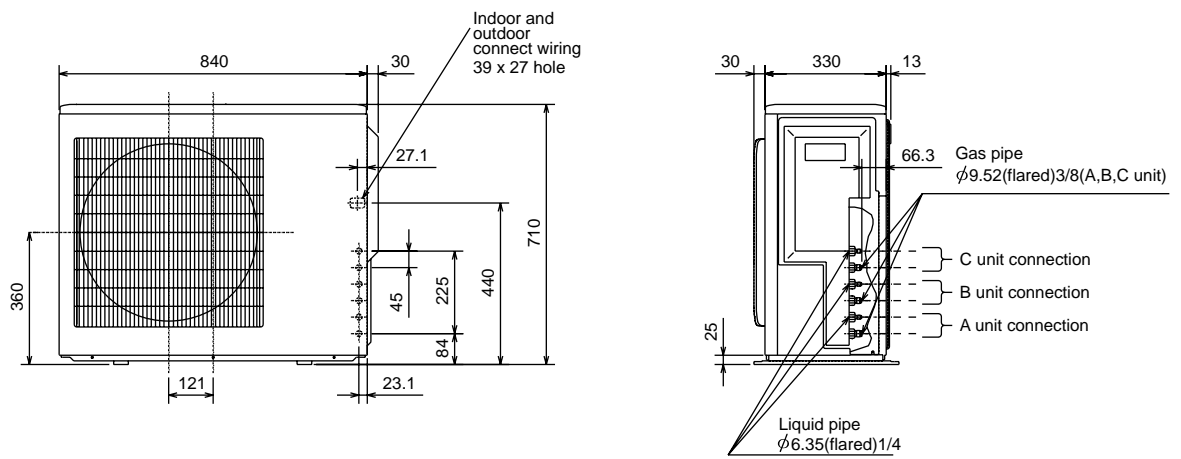
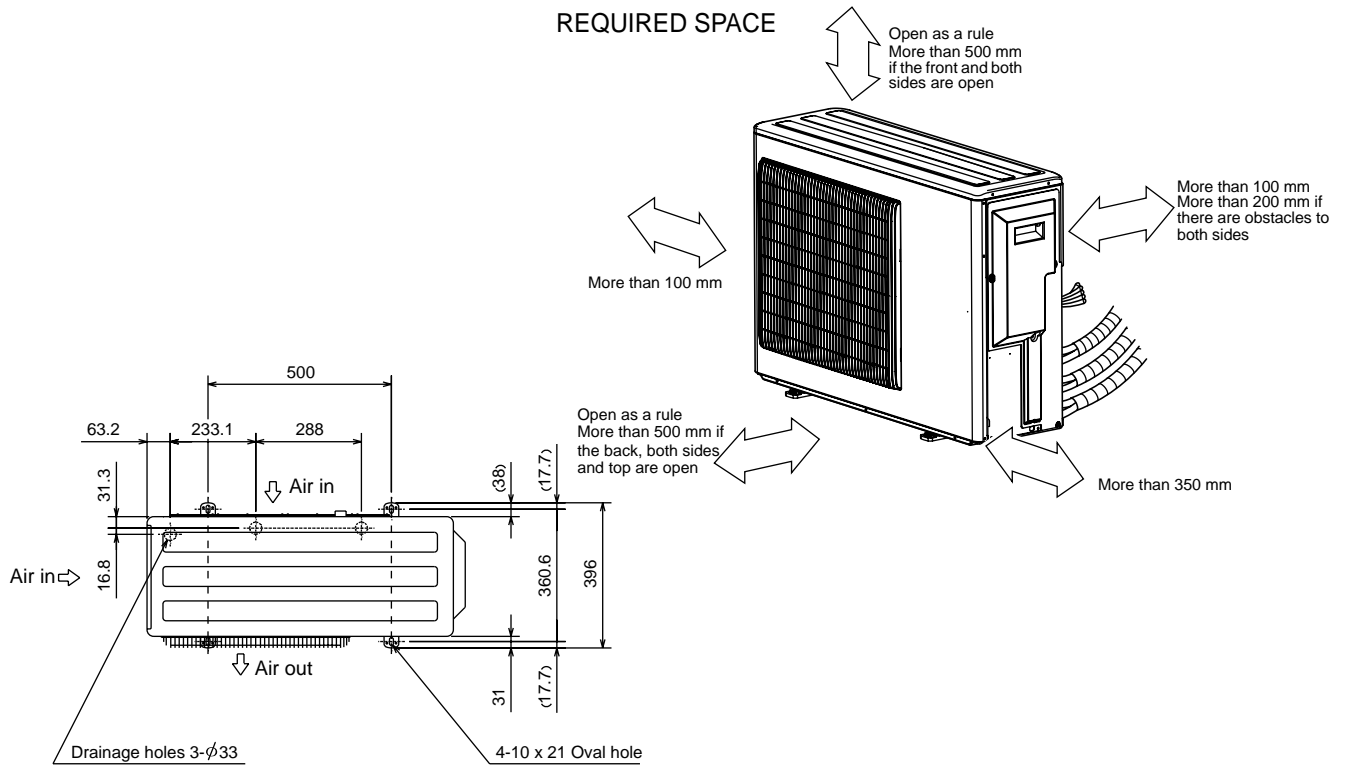

MXZ-3A54VA - [E5], [E6], [E7]

Unit: mm

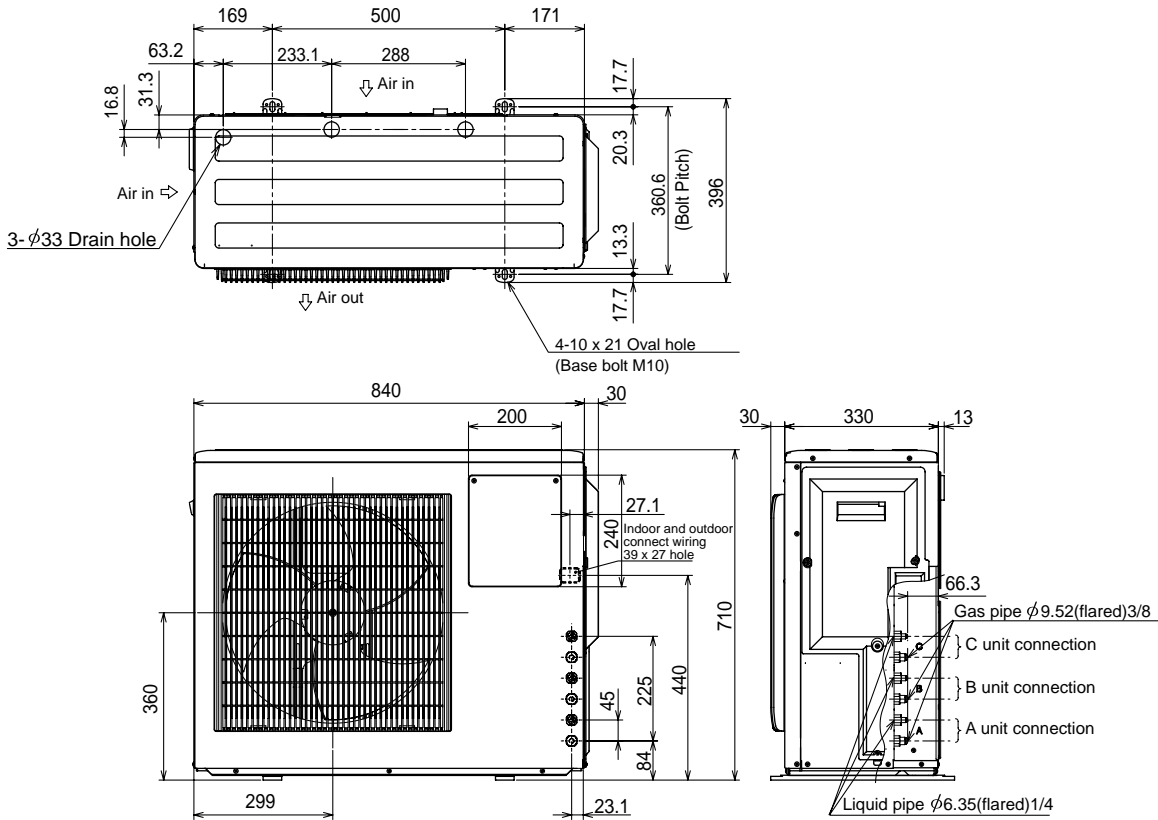

1. Installation space

Note : Leave front and both sides clearance fully.

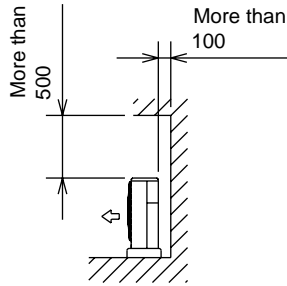

Note : Leave front and overhead clearance fully.

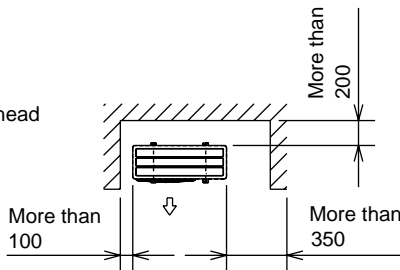

Note : Leave rear, overhead and both sides clearance fully.

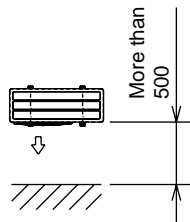

2. Service space

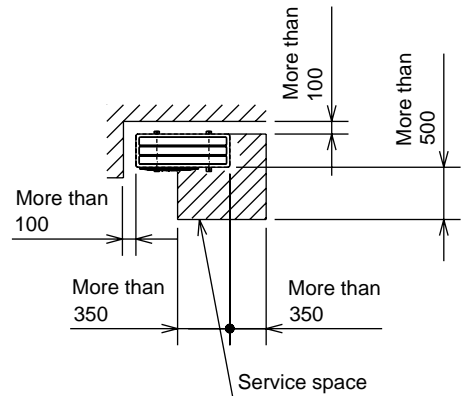

MXZ-4A71VA - [E1], [E2], [E3], [E4]

Unit: mm

REQUIRED SPACE

Open as a rule
More than 500 mm
if the front and both
sides are open

More than 100 mm

More than 100 mm
More than 200 mm if
there are obstacles to
both sides

Open as a rule
More than 500 mm if
the back, both sides
and top are open

More than 350 mm

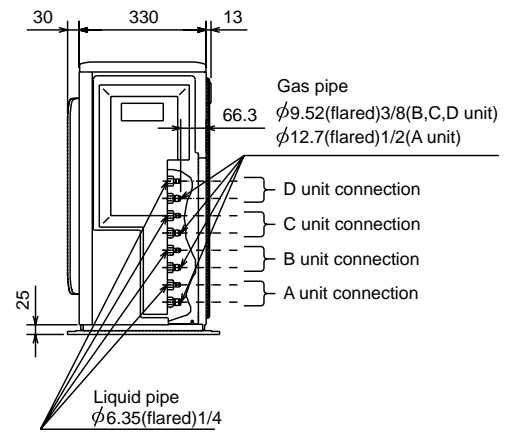
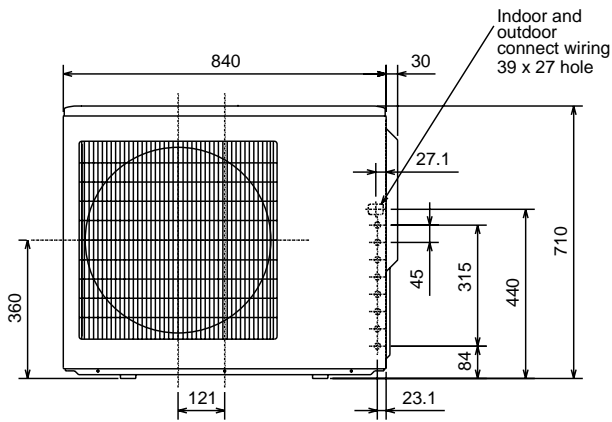
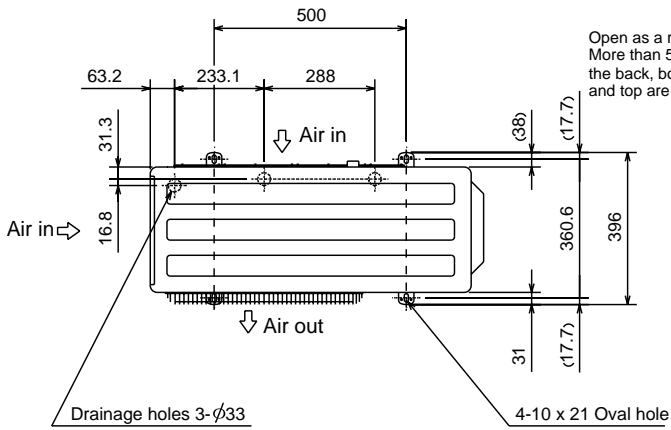

MXZ-4A71VA - E5, E6, E7

Unit: mm

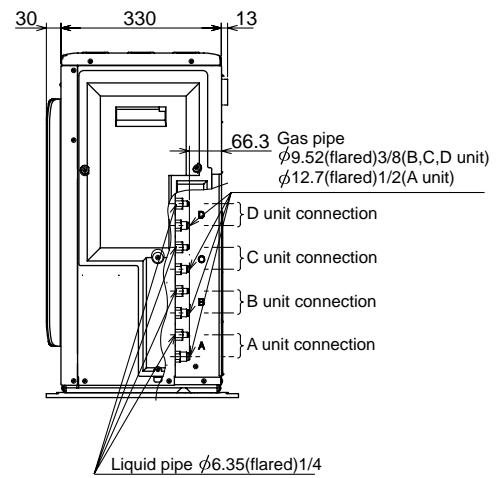
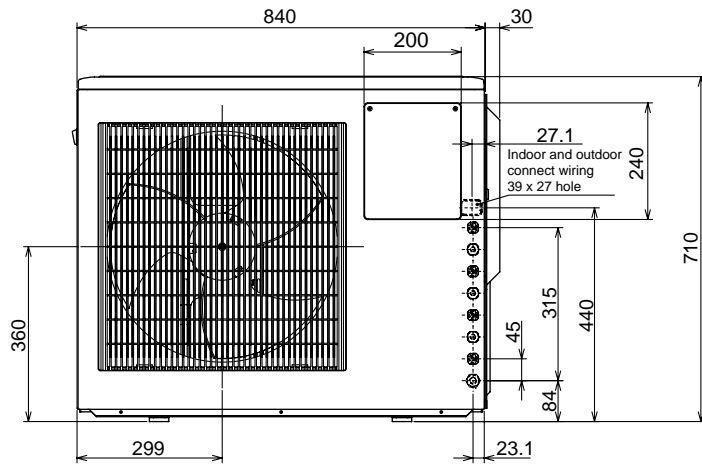
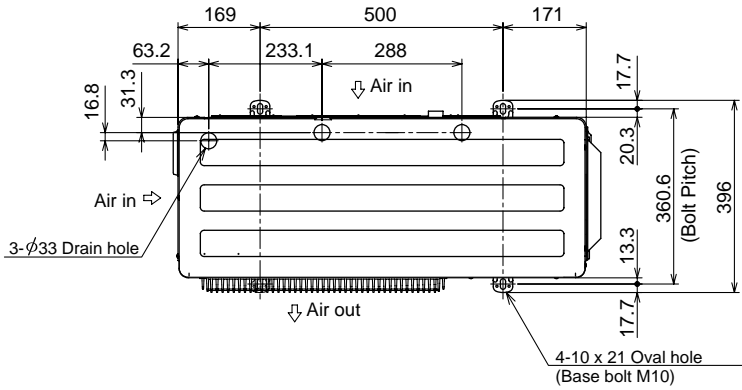

1. Installation space

Note : Leave front and both sides clearance fully.

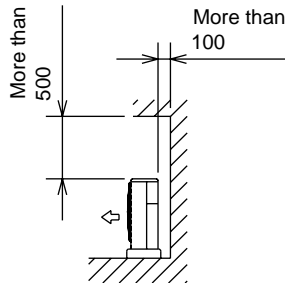

Note : Leave front and overhead clearance fully.

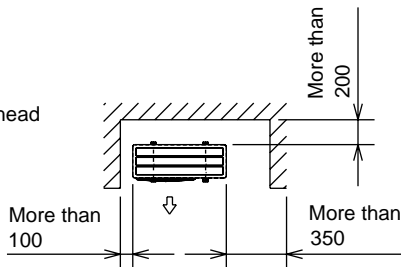

Note : Leave rear, overhead and both sides clearance fully.

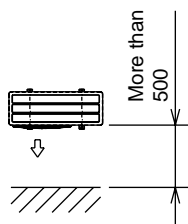

2. Service space

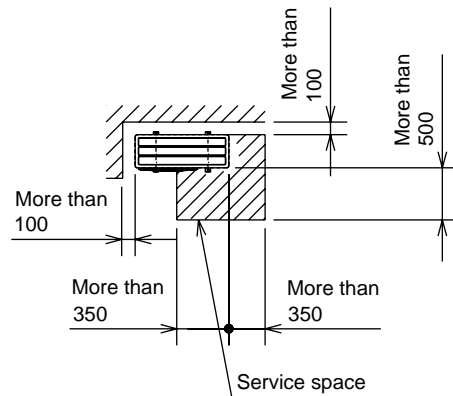

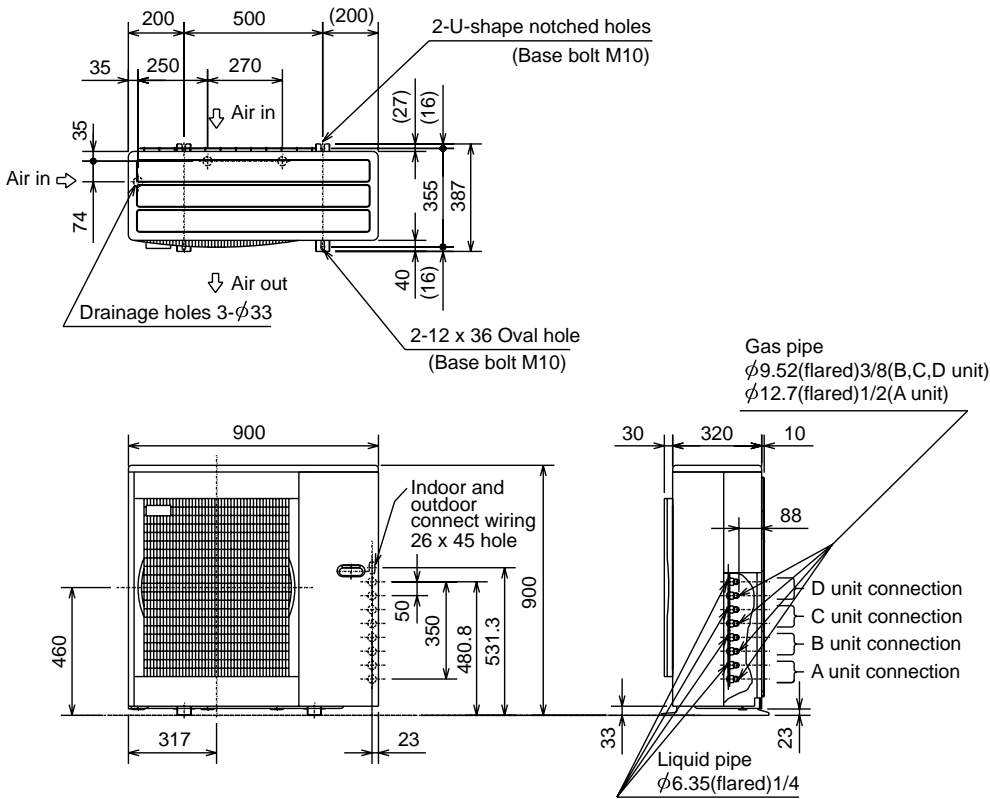

1. Installation space

Note : Leave front and both sides clearance fully.

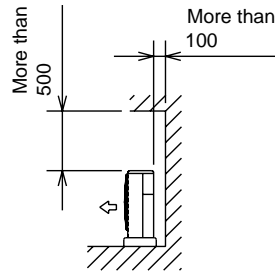

Note : Leave front and overhead clearance fully.

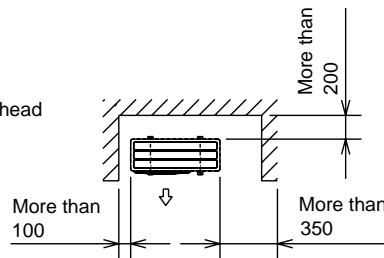

Note : Leave rear, overhead and both sides clearance fully.

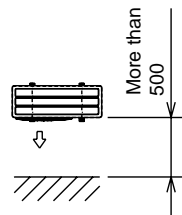

2. Service space

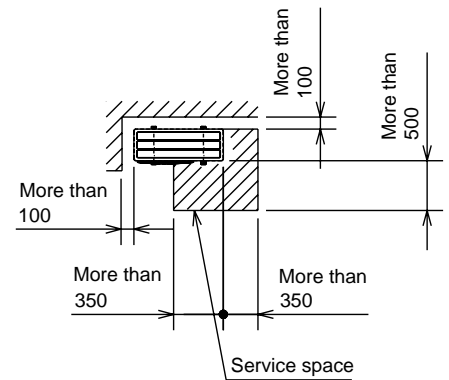

MXZ-4A80VA - E2 MXZ-5A100VA

Unit: mm

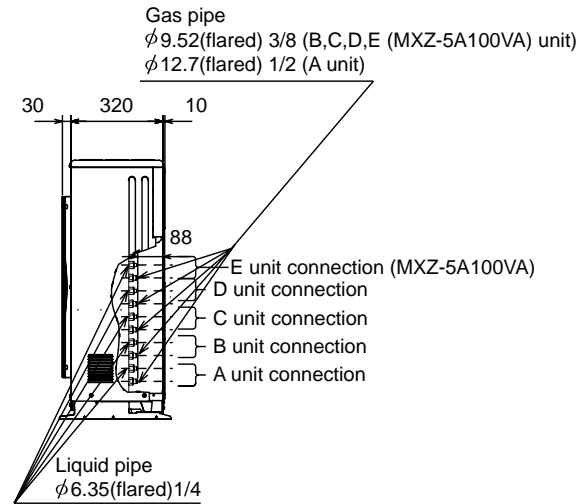
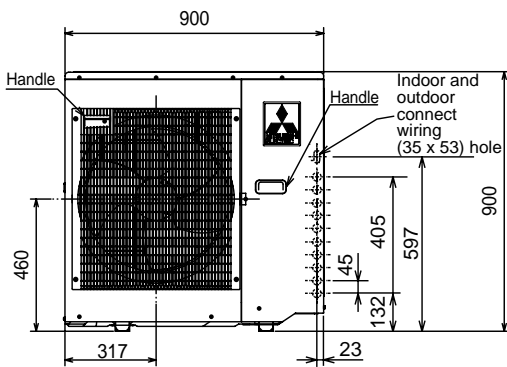
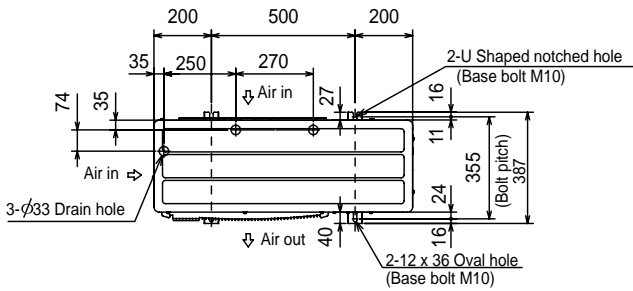

1. Installation space

Note : Leave front and both sides clearance fully.

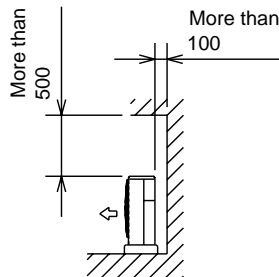

Note : Leave front and overhead clearance fully.

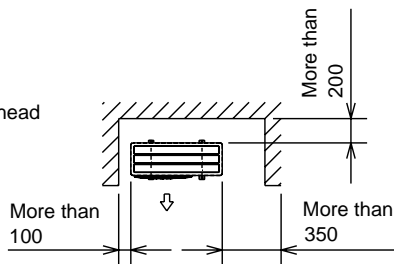

Note : Leave rear, overhead and both sides clearance fully.

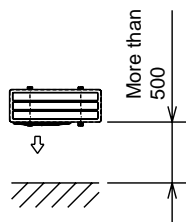

2. Service space

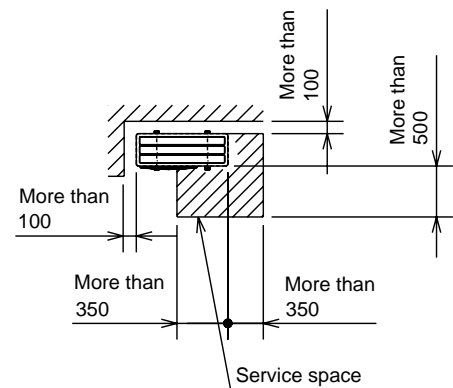

MXZ-2A30VA MXZ-2A40VA MXZ-2A52VA

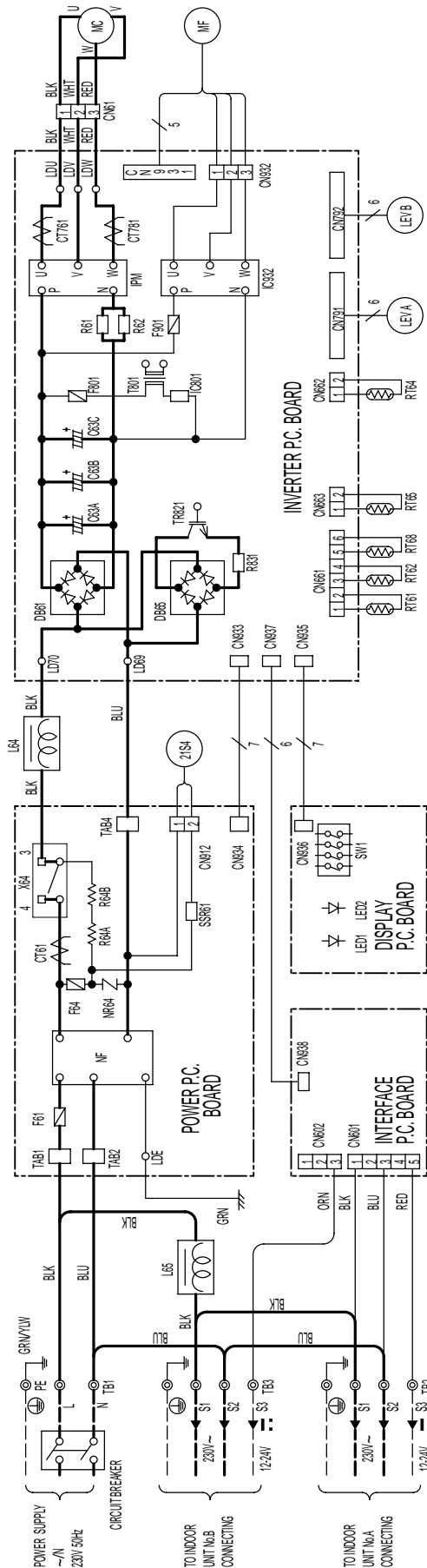

- NOTES: 1. About the indoor side electric wiring refer to the indoor unit electric wiring diagram for servicing.
 2. Use copper conductors only (for field wiring).
 3. Symbols below indicate.
 ◎: Terminal block □: Connector

SYMBOL	NAME	SYMBOL	NAME	SYMBOL	NAME
C761, C771	CURRENT TRANSFORMER	R61, R62, R63	CURRENT-DETECTING RESISTOR	RT61	SWITCHING POWER TRANSISTOR
C801, C832, C833	SMOOTHING CAPACITOR	R64A, R64B	RESISTOR	T801, T802, T803	TERMINAL BLOCK
DB61, DB65	DIODE MODULE	T801	SWITCHING POWER TRANSISTOR	LEVA, LEVB	SOLENOID COIL RELAY
F61	FUSE (T20AL/250V)	X64	RELAY		
F64, F801, F901	FUSE (T3.15AL/250V)	21S4	R.V. COIL		
IC801	INTELLIGENT POWER DEVICE	LEVA, LEVB	EXPANSION VALVE		
IPM, IC832	INTELLIGENT POWER MODULE	SSR61	SOLENOID COIL RELAY		
L64, L65	REACTOR				
MC	COMPRESSOR				

MXZ-3A54VA - E1, E2, E3

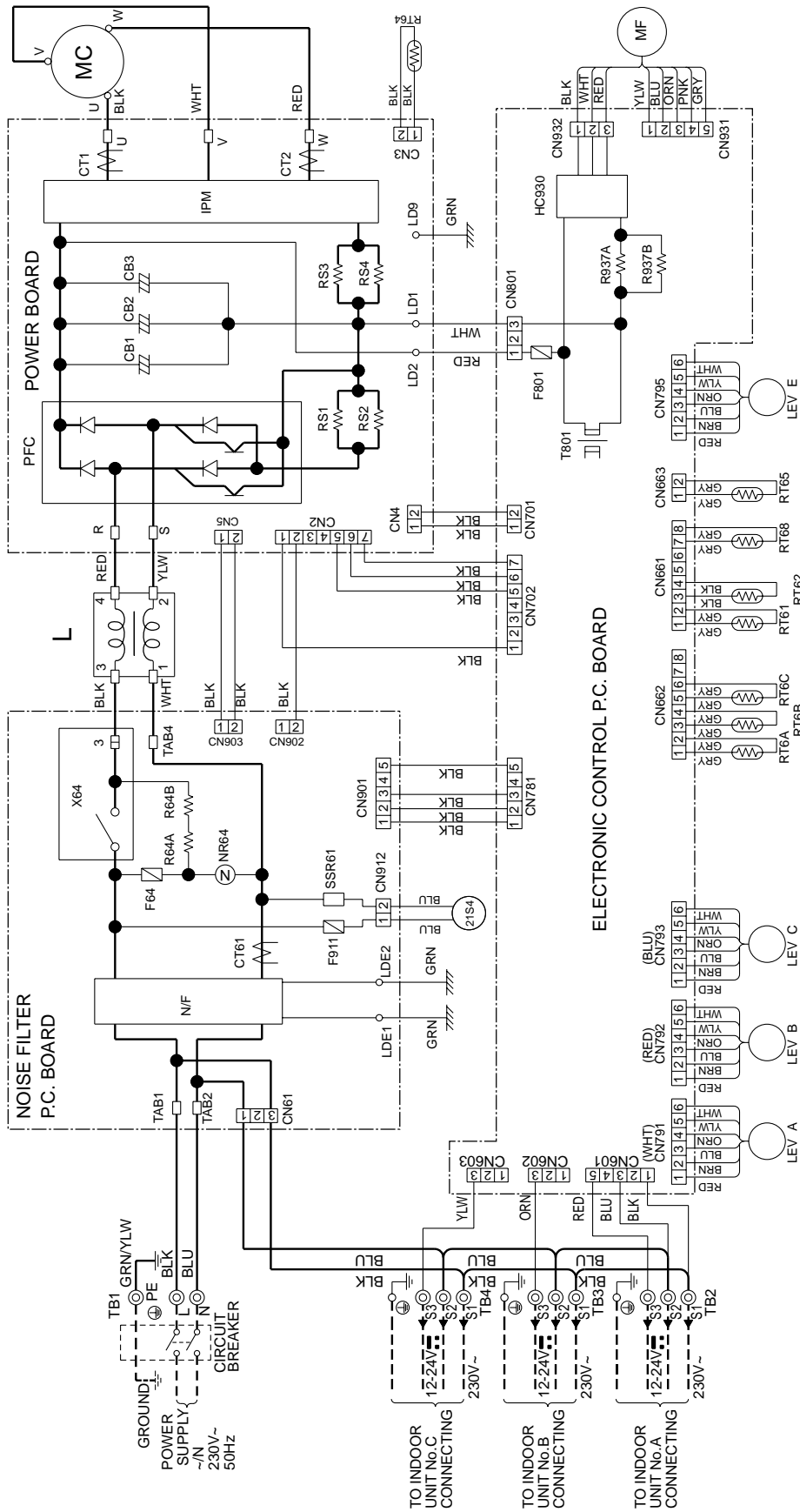

- NOTES:**
- 1. About the indoor side electric wiring refer to the indoor unit electric wiring diagram for servicing.
 - 2. Use copper conductors only (for field wiring).
 - 3. Symbols below indicate.
 - ⊙: Terminal block
 - : Connector

SYMBOL	NAME	SYMBOL	NAME	SYMBOL	NAME
CB1-3	SMOOTHING CAPACITOR	MC	COMPRESSOR	RT64	FIN TEMPERATURE THERMISTOR
CT1, 2	CURRENT TRANSFORMER	MF	OUTDOOR FAN MOTOR	RT65	AMBIENT TEMPERATURE THERMISTOR
CT61	CURRENT TRANSFORMER	NR64	VARIABLE	RT68	OUTDOOR HEAT EXCHANGER TEMPERATURE THERMISTOR
F64	FUSE (T2AL250V)	N/F	NOISE FILTER	SSR61	SOLENOID COIL RELAY
F801	FUSE (T3.15AL250V)	PFC	POWER FACTOR CONTROLLER	T801	TRANSFORMER
F911	FUSE (T1AL250V)	R64A, B	RESISTOR	TB1-4	TERMINAL BLOCK
HC930	INTELLIGENT POWER MODULE	R937A, B	RESISTOR	X64	RELAY
IPM	INTELLIGENT POWER MODULE	RS1-4	RESISTOR	21S4	R.V. COIL
L	REACTOR	RT6A-C	GAS PIPE TEMPERATURE THERMISTOR		
LEVA-C	EXPANSION VALVE	RT61	DEFROST THERMISTOR		
LEV E	EXPANSION VALVE	RT62	DISCHARGE TEMPERATURE THERMISTOR		

MXZ-3A54VA - E4

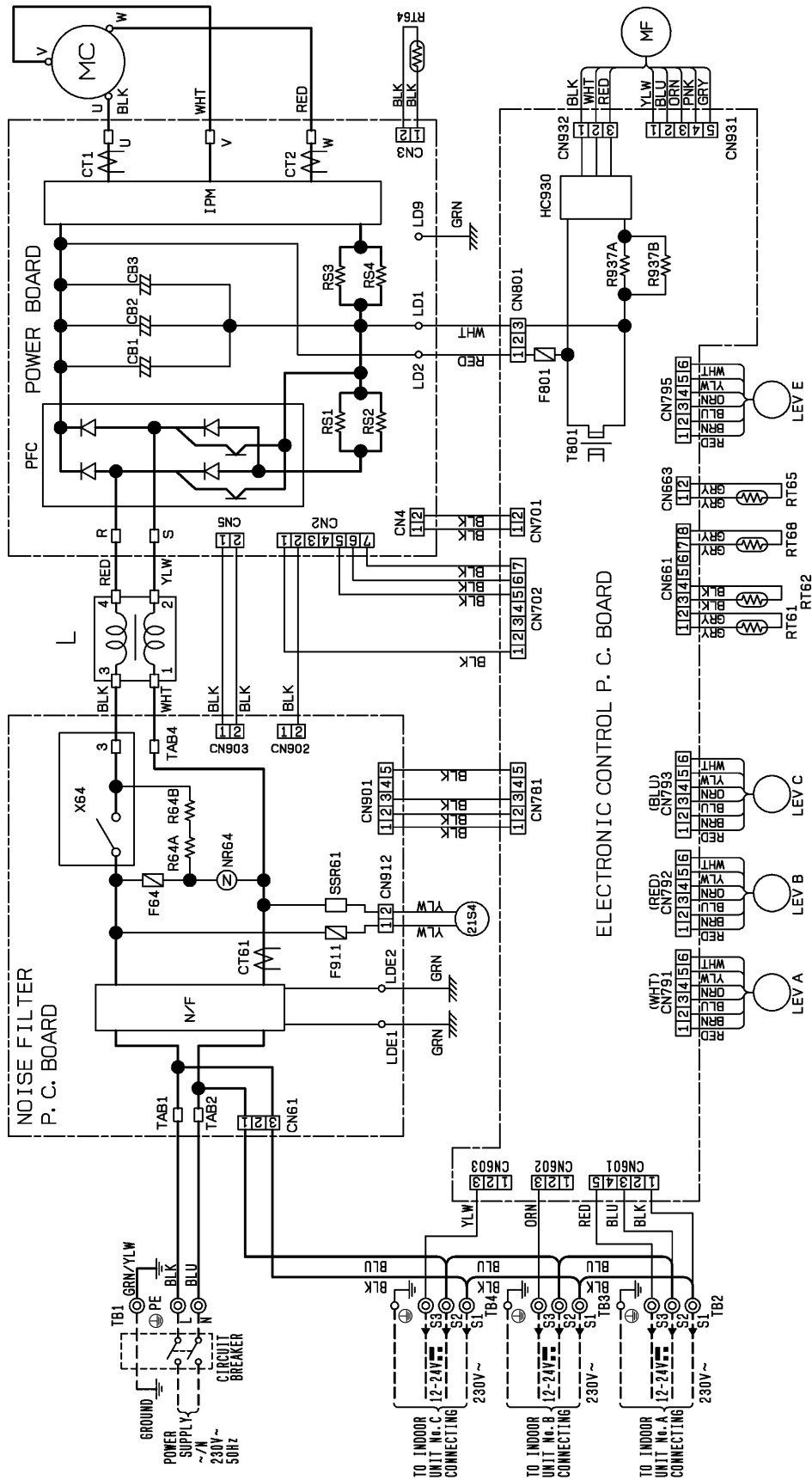

- NOTES:
1. About the indoor side electric wiring refer to the indoor unit electric wiring diagram for servicing.
 2. Use copper conductors only (for field wiring).
 3. Symbols below indicate.
 - ⊕: Terminal block
 - : Connector

SYMBOL	NAME	SYMBOL	NAME	SYMBOL	NAME
CB1-3	SMOOTHING CAPACITOR	MC	COMPRESSOR	RT65	AMBIENT TEMPERATURE THERMISTOR
CT1, 2	CURRENT TRANSFORMER	MF	OUTDOOR FAN MOTOR	RT66	OUTDOOR HEAT EXCHANGER TEMPERATURE THERMISTOR
CT61	CURRENT TRANSFORMER	NR64	VARIATOR	SSR61	SOLENOID COIL RELAY
F64	FUSE (T2AL250V)	N/F	NOISE FILTER	T801	POWER FACTOR CONTROLLER
F801	FUSE (T3.15A/250V)	PFC	POWER FACTOR CONTROLLER	TB1-4	TERMINAL BLOCK
F911	FUSE (T1A/250V)	R64A, B	RESISTOR	X64	RELAY
HC930	INTELLIGENT POWER MODULE	R937A, B	RESISTOR	21S4	R.V. COIL
IPM	INTELLIGENT POWER MODULE	RS1-4	RESISTOR		
L	REACTOR	RT61	DEFROST THERMISTOR		
LEVA-C	EXPANSION VALVE	RT62	DISCHARGE TEMPERATURE THERMISTOR		
LEVE	EXPANSION VALVE	RT64	FIN TEMPERATURE THERMISTOR		

MXZ-4A71VA - E1, E2, E3

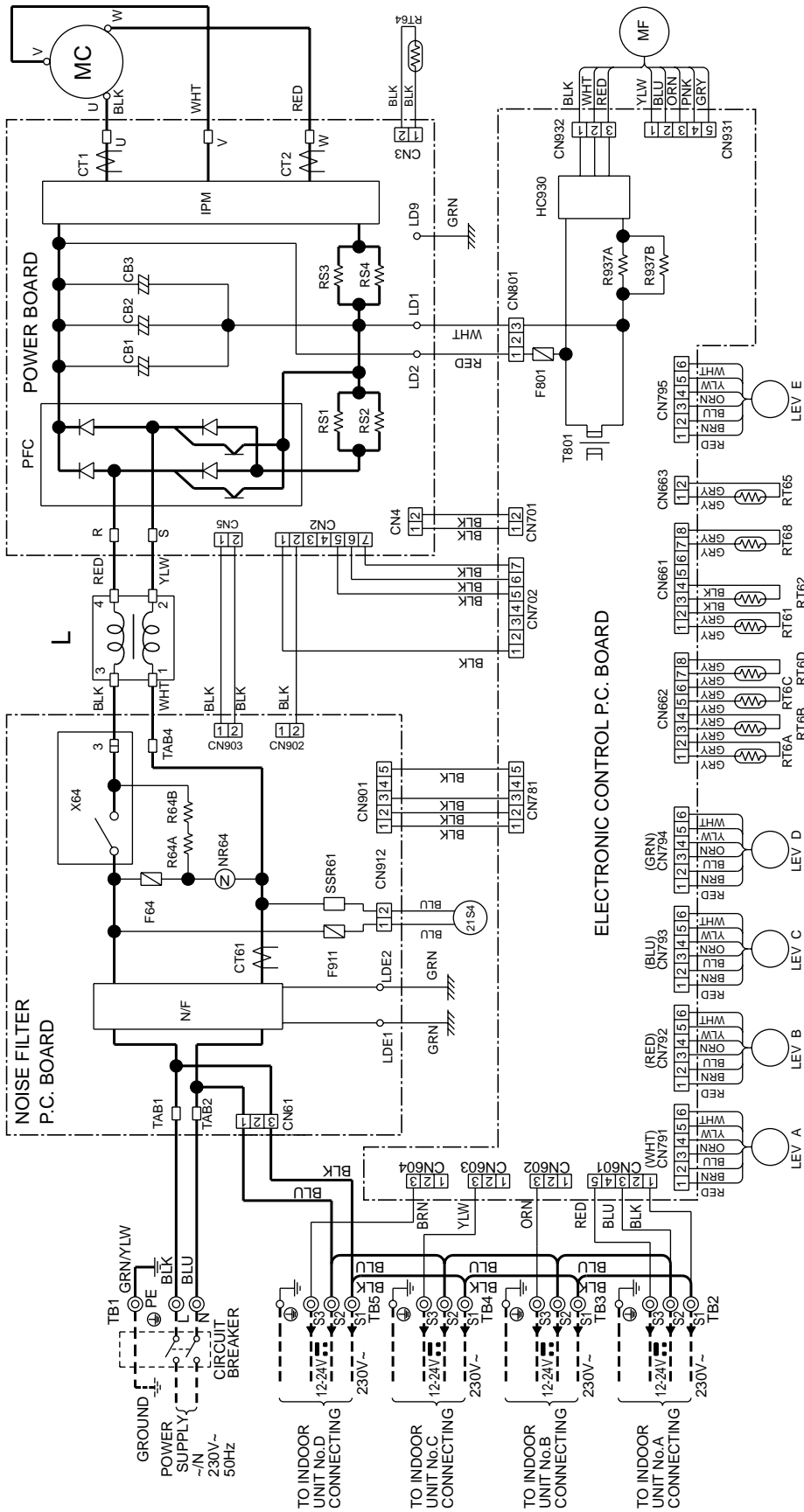

- NOTES:**
1. About the indoor side electric wiring refer to the indoor unit electric wiring diagram for servicing.
 2. Use copper conductors only (for field wiring).
 3. Symbols below indicate.
 ◎: Terminal block □: Connector

SYMBOL	NAME	SYMBOL	NAME	SYMBOL	NAME
CB1-3	SMOOTHING CAPACITOR	MC	COMPRESSOR	RT64	FIN TEMPERATURE THERMISTOR
CT1, 2	CURRENT TRANSFORMER	MF	OUTDOOR FAN MOTOR	RT65	AMBIENT TEMPERATURE THERMISTOR
CT61	CURRENT TRANSFORMER	NR64	VARIABLE	RT68	OUTDOOR HEAT EXCHANGER TEMPERATURE THERMISTOR
F64	FUSE (T2AL250V)	N/F	NOISE FILTER	SSR61	SOLENOID COIL RELAY
F911	FUSE (T3.15AL250V)	R64A, B	RESISTOR	T801	TRANSFORMER
HC930	INTELLIGENT POWER MODULE	R937A, B	RESISTOR	TB1-5	TERMINAL BLOCK
IPM	INTELLIGENT POWER MODULE	RS1-4	RESISTOR	X64	RELAY
L	REACTOR	RT6A-D	GAS PIPE TEMPERATURE THERMISTOR	21S4	R.V. COIL
LEV A-D	EXPANSION VALVE	RT61	DEFROST THERMISTOR		
LEV E	EXPANSION VALVE	RT62	DISCHARGE TEMPERATURE THERMISTOR		

MXZ-4A71VA - E4

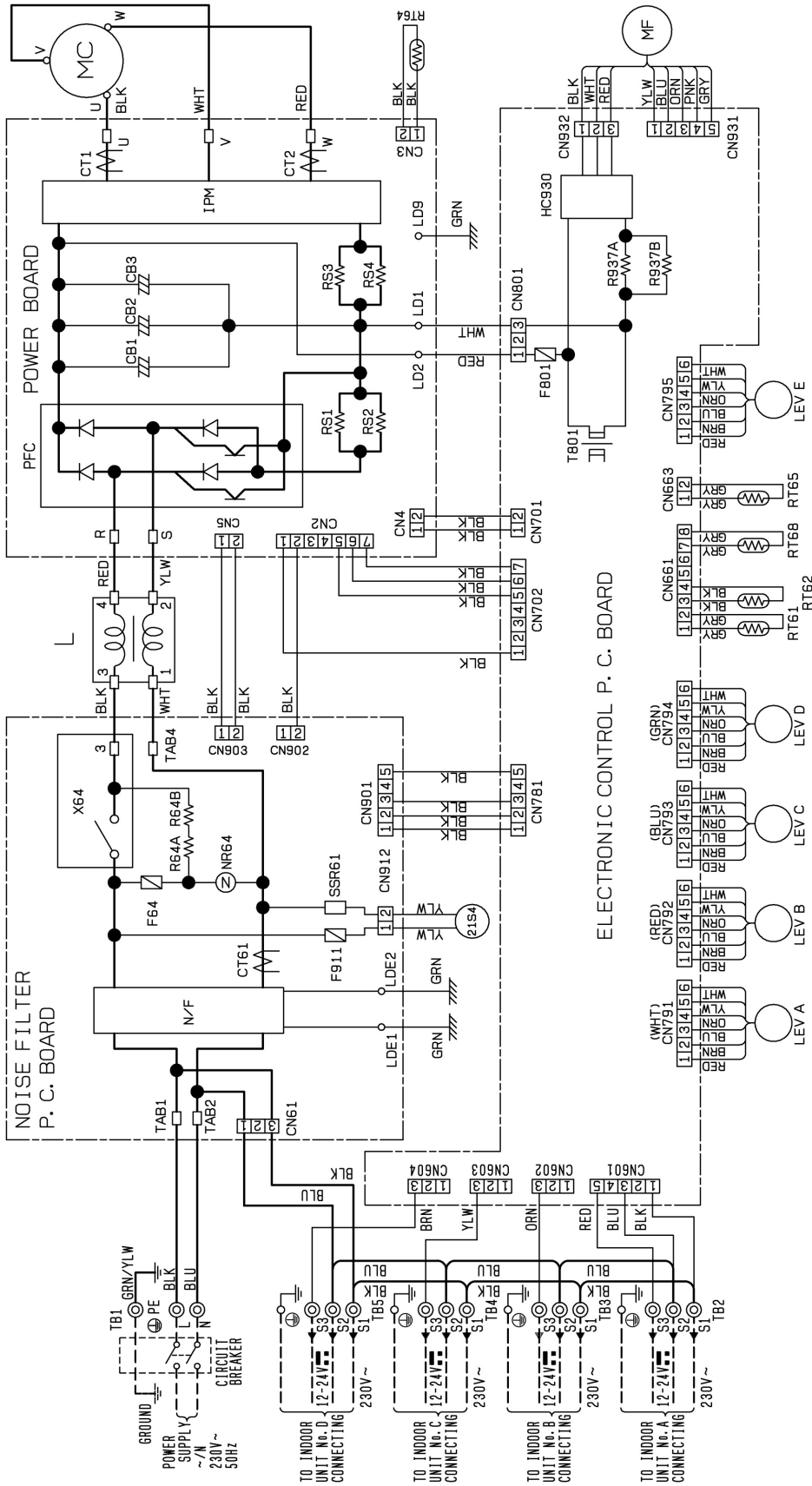

- NOTES:
1. About the indoor side electric wiring refer to the indoor unit electric wiring diagram for servicing.
 2. Use copper conductors only (for field wiring).
 3. Symbols below indicate.
 ○: Terminal block
 □: Connector

SYMBOL	NAME	SYMBOL	NAME	SYMBOL	NAME
CB1-3	SMOOTHING CAPACITOR	MC	COMPRESSOR	RT65	AMBIENT TEMPERATURE THERMISTOR
CT1, 2	CURRENT TRANSFORMER	MF	OUTDOOR FAN MOTOR	RT68	OUTDOOR HEAT EXCHANGER TEMPERATURE THERMISTOR
CT61	CURRENT TRANSFORMER	NR64	VARIABLE	SSR61	SOLENOID COIL RELAY
F64	FUSE (T2AL250V)	N/F	NOISE FILTER	T801	TRANSFORMER
F911	FUSE (T3.15AL250V)	PFC	POWER FACTOR CONTROLLER	TB1-5	TERMINAL BLOCK
HC930	INTELLIGENT POWER MODULE	R64A, B	RESISTOR	X64	REACTOR
IPM	INTELLIGENT POWER MODULE	RS1-4	RESISTOR	21S4	R.V. COIL
L	REACTOR	RT61	DEFROST THERMISTOR		
LEVA-D	EXPANSION VALVE	RT62	DISCHARGE TEMPERATURE THERMISTOR		
LEVE	EXPANSION VALVE	RT64	FIN TEMPERATURE THERMISTOR		

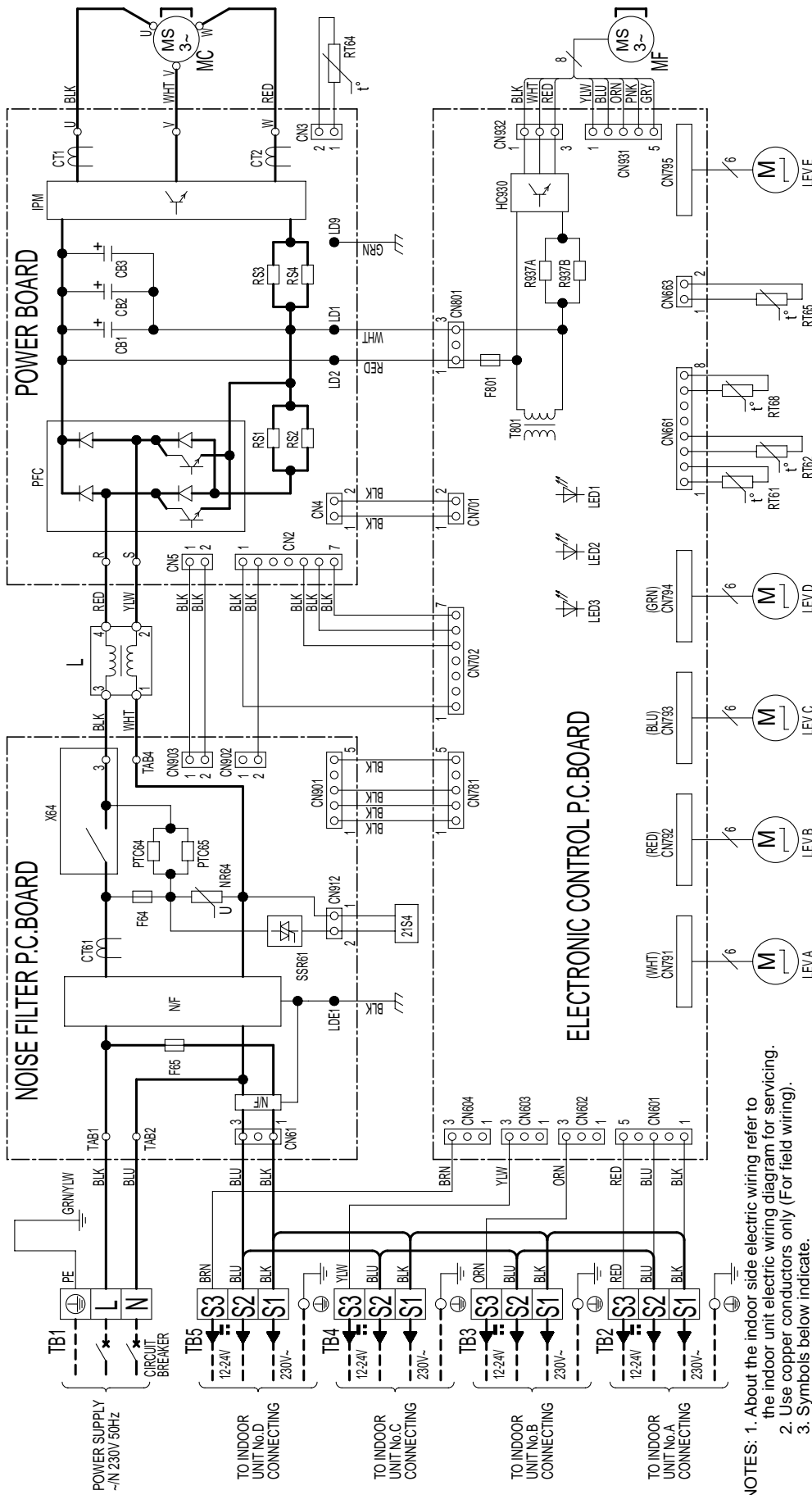

NOTES: 1. About the indoor side electric wiring refer to the indoor unit electric wiring diagram for servicing.
 2. Use copper conductors only (For field wiring).
 3. Symbols below indicate.
 □□□□ : Terminal block □□□□ : Connector

SYMBOL	NAME	SYMBOL	NAME	SYMBOL	NAME	SYMBOL	NAME
CB1-3	SMOOTHING CAPACITOR	HC930	INTELLIGENT POWER MODULE	RS1-4	RESISTOR	SSR61	SOLENOID COIL RELAY
CT1,2	CURRENT TRANSFORMER	IPM	INTELLIGENT POWER MODULE	RT61	DEFROST THERMISTOR	T801	TRANSFORMER
CT61	CURRENT TRANSFORMER	L	REACTOR	RT62	DISCHARGE TEMP.THERMISTOR	TB1-5	TERMINAL BLOCK
F64	FUSE(T2AL250V)	LEV A-D	EXPANSION VALVE	RT64	POWER FACTOR CONTROLLER	X64	RELAY
F65	FUSE(T6.3AL250V)	LEV E	EXPANSION VALVE	RT65	AMBIENT TEMP.THERMISTOR	Z1S4	REVERSING VALVE SOLENOID COIL
F801	FUSE(T3.15AL250V)	MC	COMPRESSOR	RT68	OUTDOOR HEAT EXCHANGER TEMP.THERMISTOR		

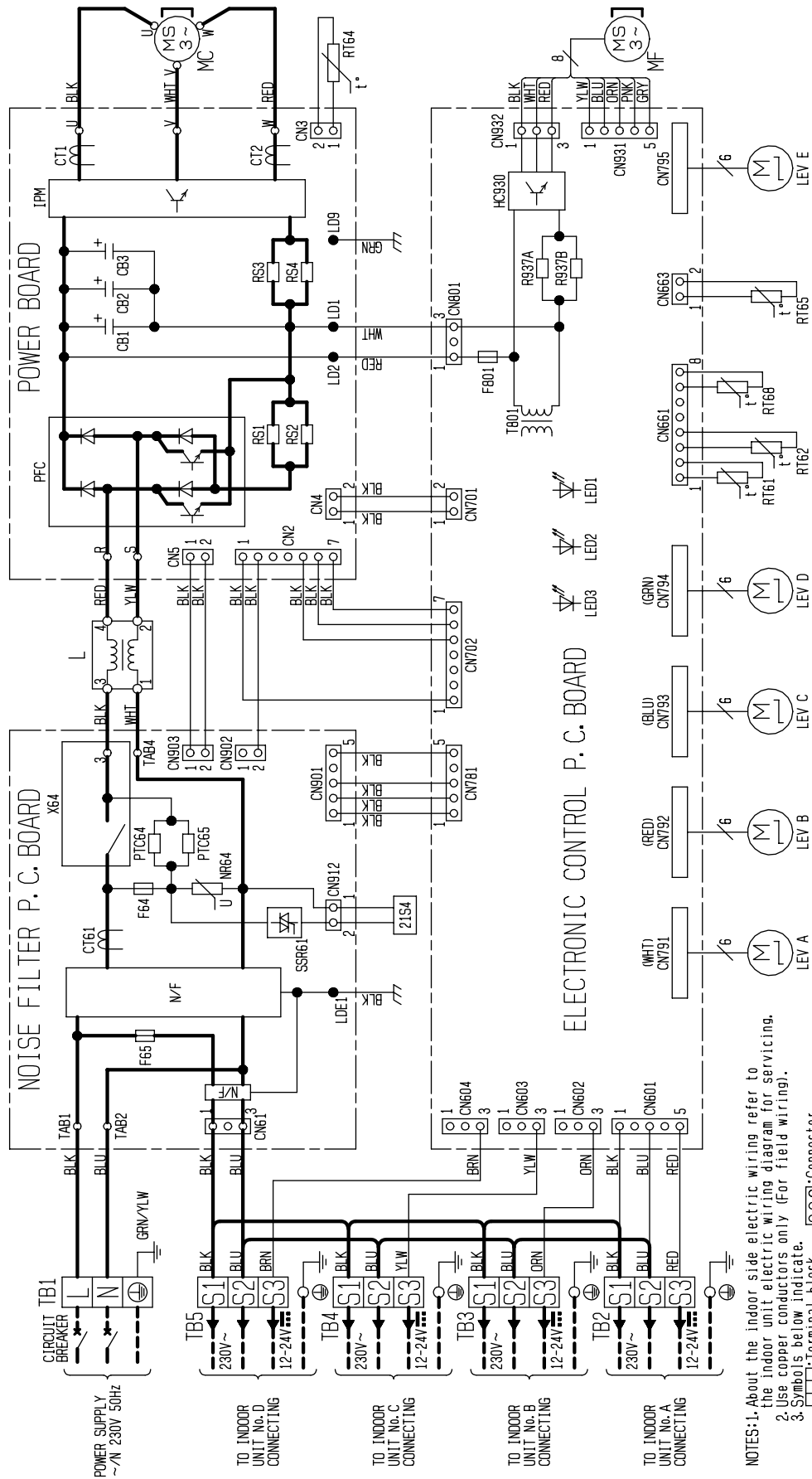

NOTES: 1. About the indoor side electric wiring refer to the indoor unit electric wiring diagram for servicing.
 2. Use copper conductors only (For field wiring).
 3. Symbols below indicate.
 □: Terminal block
 ○: Connector

SYMBOL	NAME	SYMBOL	NAME	SYMBOL	NAME	SYMBOL	NAME
HC930	INTELLIGENT POWER MODULE	MF	FAN MOTOR	RS1~4	RESISTOR	SSR61	SOLENOID COIL RELAY
IPM	CURRENT TRANSFORMER	NR64	VARIABLE RESISTOR	RT61	DEFROST THERMISTOR	T801	TRANSFORMER
L	REACTOR	N/F	NOISE FILTER	RT62	DISCHARGE TEMP. THERMISTOR	TB1~5	TERMINAL BLOCK
LEV A~D	EXPANSION VALVE	PTC64, 65	POWER FACTOR CONTROLLER	RT64	FIN TEMP. THERMISTOR	X64	RELAY
LEV E	FUSE (16, 3A/250V)	CIRCUIT PROTECTION	CIRCUIT PROTECTION	RT65	AMBIENT TEMP. THERMISTOR	2154	REVERSING VALVE SOLENOID COIL
MC	COMPRESSOR	R937A, B	RESISTOR	RT68	OUTDOOR HEAT EXCHANGER TEMP. THERMISTOR		

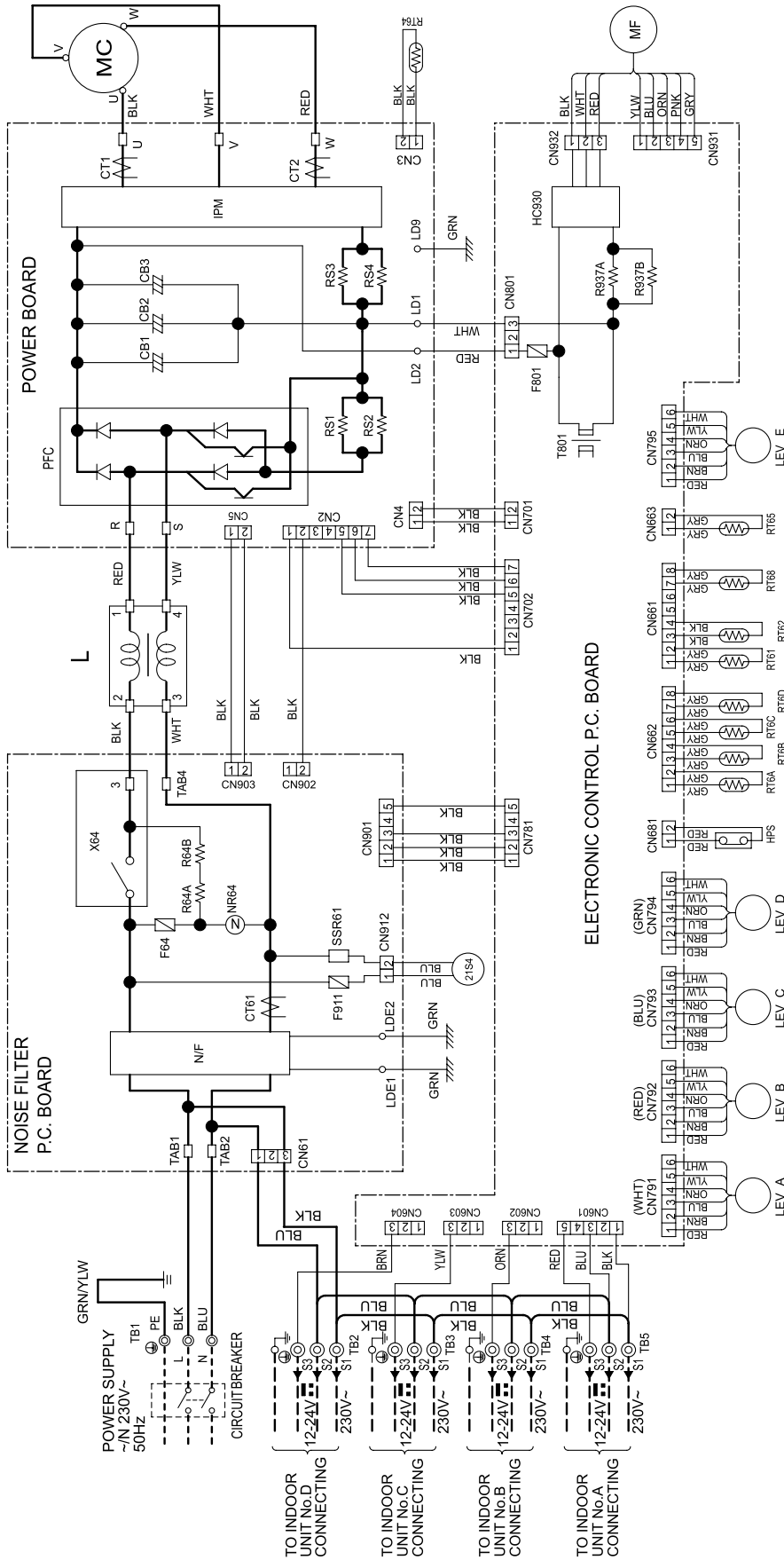

NOTES: 1. About the indoor side electric wiring refer to the indoor unit electric wiring diagram for servicing.
 2. Use copper conductors only (for field wiring).
 3. Symbols below indicate.
 ©: Terminal block □: Connector

SYMBOL	NAME	SYMBOL	NAME	SYMBOL	NAME
CB1-3	SMOOTHING CAPACITOR	LEV E	EXPANSION VALVE	RT62	DISCHARGE TEMPERATURE THERMISTOR
CT1, 2	CURRENT TRANSFORMER	MC	COMPRESSOR	RT64	FIN TEMPERATURE THERMISTOR
CT61	CURRENT TRANSFORMER	MF	OUTDOOR FAN MOTOR	RT65	AMBIENT TEMPERATURE THERMISTOR
F64	FUSE (T2AL250V)	NR64	VARIATOR	RT68	OUTDOOR HEAT EXCHANGER TEMPERATURE THERMISTOR
F801	FUSE (T3.15AL250V)	N/F	NOISE FILTER	SSR61	SOLENOID COIL RELAY
F911	FUSE (T1AL250V)	PFC	POWER FACTOR CONTROLLER	T801	TRANSFORMER
HC930	INTELLIGENT POWER MODULE	R64A/B	RESISTOR	TB1-5	TERMINAL BLOCK
IPM	HIGH PRESSURE SWITCH	R937A, B	RESISTOR	X64	RELAY
L	REACTOR	RS1-4	RESISTOR	21S4	R.V. COIL
LEV A-D	EXPANSION VALVE	RT6A-D	GAS PIPE TEMPERATURE THERMISTOR	RT61	DEFROST THERMISTOR

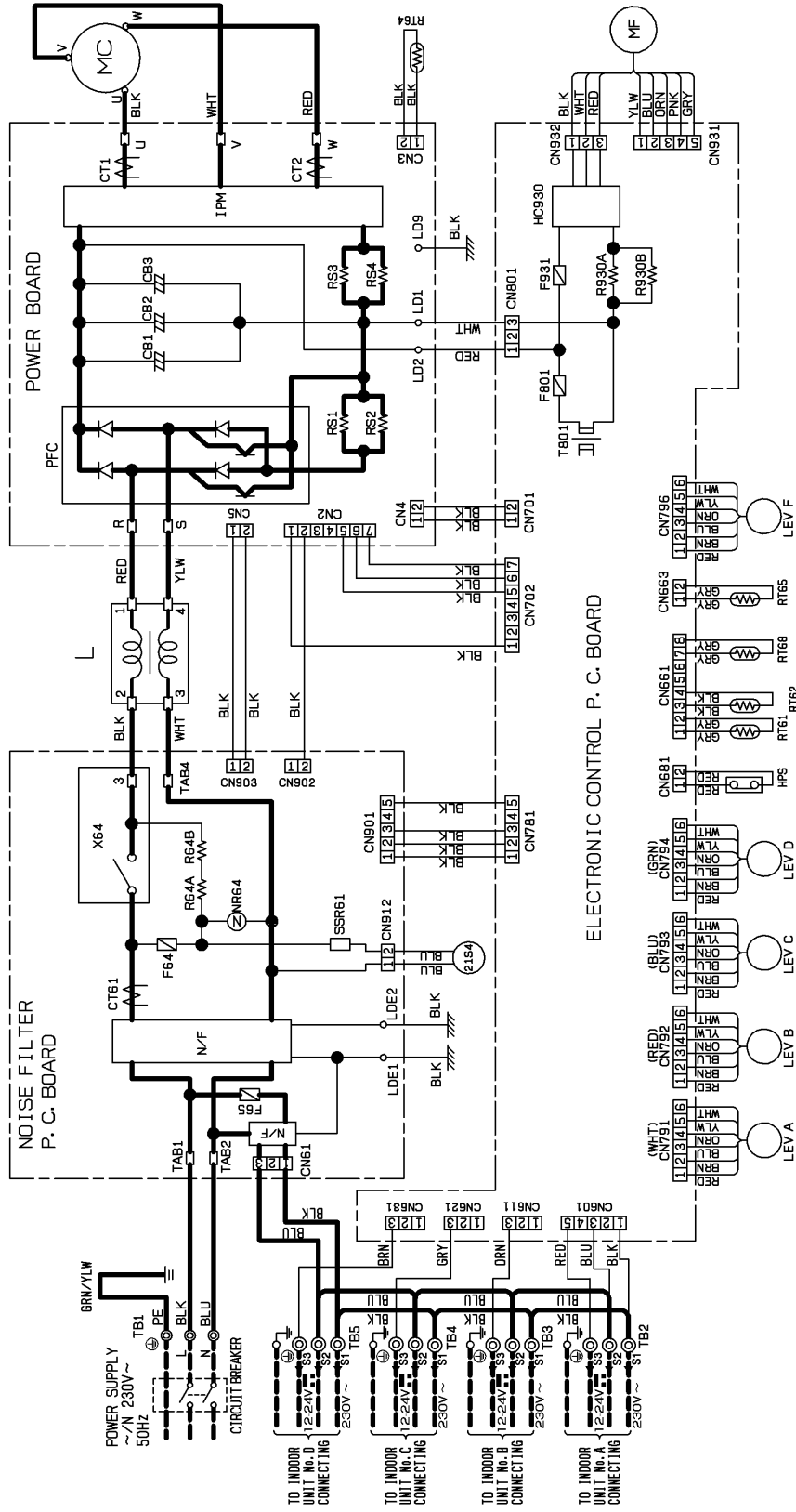

- NOTES:
1. About the indoor side electric wiring refer to the indoor unit electric wiring diagram for servicing.
 2. Use copper conductors only (for field wiring).
 3. Symbols below indicate.
 - ⊠: Terminal block
 - : Connector

SYMBOL	NAME	SYMBOL	NAME	SYMBOL	NAME
CB1-3	SMOOTHING CAPACITOR	LEV A-D	EXPANSION VALVE	RT62	DISCHARGE TEMPERATURE THERMISTOR
CT1, 2	CURRENT TRANSFORMER	LEV F	EXPANSION VALVE	RT64	FIN TEMPERATURE THERMISTOR
CT61	CURRENT TRANSFORMER	MC	COMPRESSOR	RT65	AMBIENT TEMPERATURE THERMISTOR
F64	FUSE (T2AL250V)	MF	OUTDOOR FAN MOTOR	RT68	OUTDOOR HEAT EXCHANGER TEMPERATURE THERMISTOR
F65	FUSE (T6.3AL250V)	NR64	VARIABLE	SSR61	SOLENOID COIL RELAY
F801	FUSE (T3.15AL250V)	N/F	NOISE FILTER	T801	TRANSFORMER
F931	FUSE (T3.15AL250V)	PFC	POWER FACTOR CONTROLLER	TB1-5	TERMINAL BLOCK
HC930	INTELLIGENT POWER MODULE	R64A, B	RESISTOR	X64	RELAY
HPS	HIGH PRESSURE SWITCH	R930A, B	RESISTOR	21S4	R.V. COIL
IPM	INTELLIGENT POWER MODULE	RS1-4	RESISTOR	RT61	DEFROST THERMISTOR
L	REACTOR	RT61	DEFROST THERMISTOR		

MXZ-5A100VA

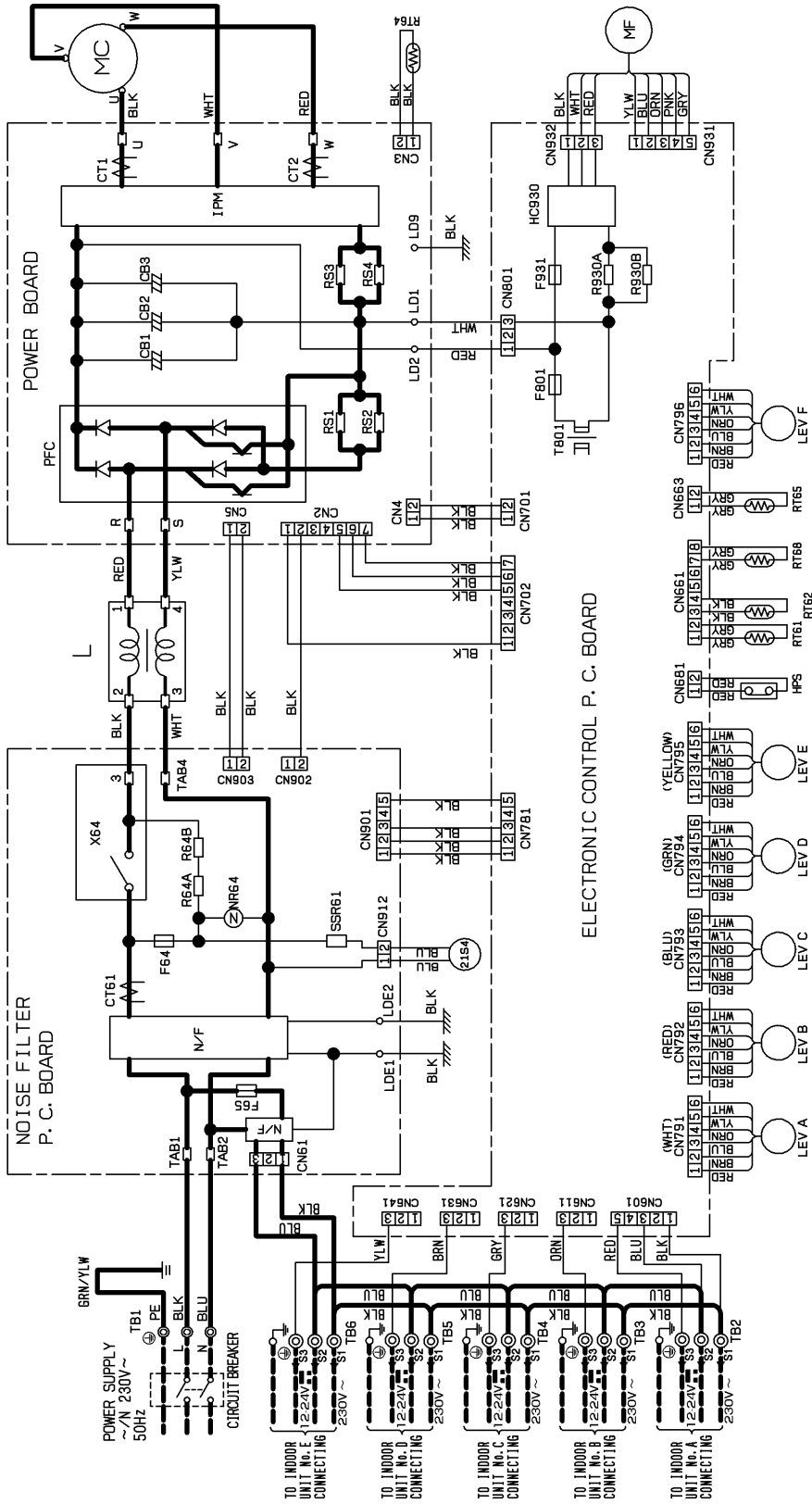

- NOTES: 1. About the indoor side electric wiring refer to the indoor unit electric wiring diagram for servicing.
 2. Use copper conductors only (for field wiring).
 3. Symbols below indicate.
 ◎:Terminal block □:Connector

SYMBOL	NAME	SYMBOL	NAME	SYMBOL	NAME
CB1-3	SMOOTHING CAPACITOR	LEV A-E	EXPANSION VALVE	RT62	DISCHARGE TEMPERATURE THERMISTOR
CT1, 2	CURRENT TRANSFORMER	LEV F	EXPANSION VALVE	RT64	FIN TEMPERATURE THERMISTOR
CT61	CURRENT TRANSFORMER	MC	COMPRESSOR	RT65	AMBIENT TEMPERATURE THERMISTOR
F64	FUSE (T2AL250V)	MF	OUTDOOR FAN MOTOR	RT68	OUTDOOR HEAT EXCHANGER TEMPERATURE THERMISTOR
F65	FUSE (T6.3AL250V)	NR64	VARIABLE	SSR61	SOLENOID COIL RELAY
F801	FUSE (T3.15AL250V)	N/F	NOISE FILTER	T801	TRANSFORMER
F931	FUSE (T3.15AL250V)	PFC	POWER FACTOR CONTROLLER	TB1-6	TERMINAL BLOCK
HC930	INTELLIGENT POWER MODULE	R64A,B	RESISTOR	X64	RELAY
IPM	HIGH PRESSURE SWITCH	R930A, B	RESISTOR	21S4	R.V. COIL
L	INTELLIGENT POWER MODULE	RS1-4	RESISTOR	RT61	DEFROST THERMISTOR
	REACTOR				

MXZ-2A30VA

UNIT: mm

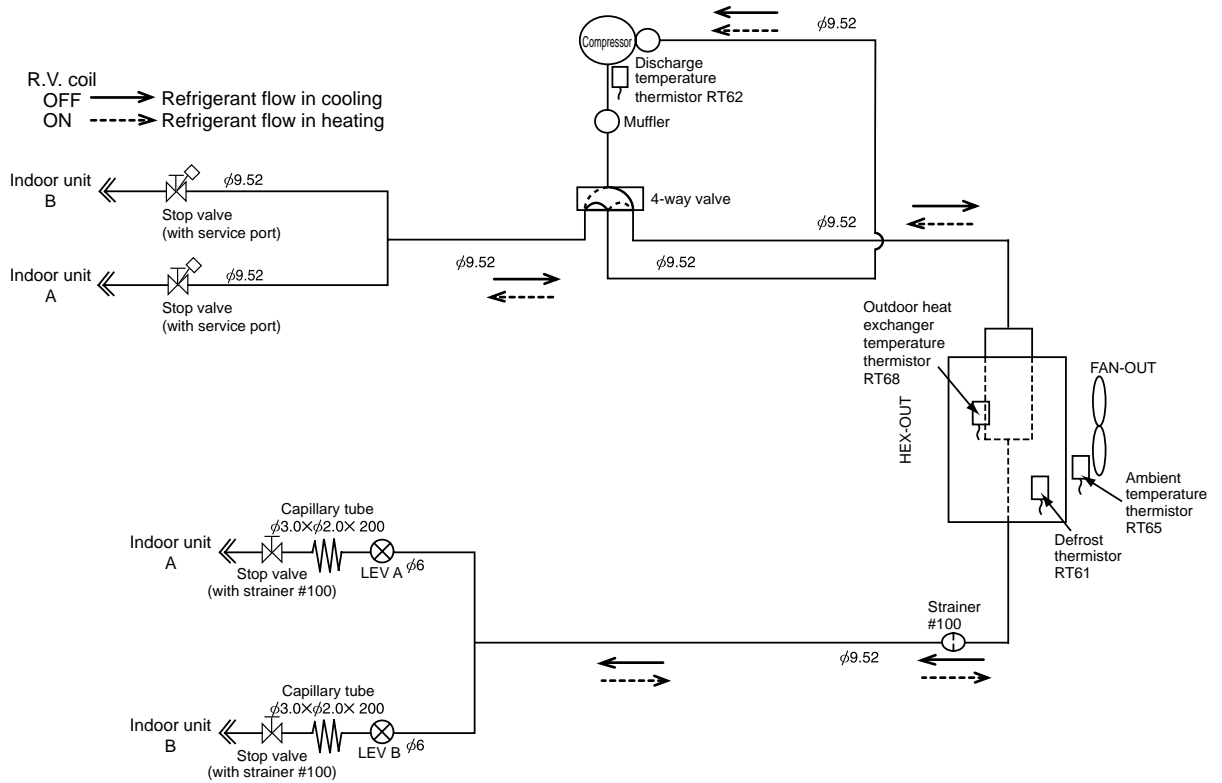

MAX REFRIGERANT PIPING LENGTH

Piping length each indoor unit (a, b)	15m
Total piping length (a+b)	20m
Bending point for each unit	15
Total bending point	20

*It is irrelevant which unit is higher.

ADDITIONAL REFRIGERANT CHARGE

Outdoor unit precharged (g)	Refrigerant piping length (one way, 2 unit total)	
	20m	
1,150	0	

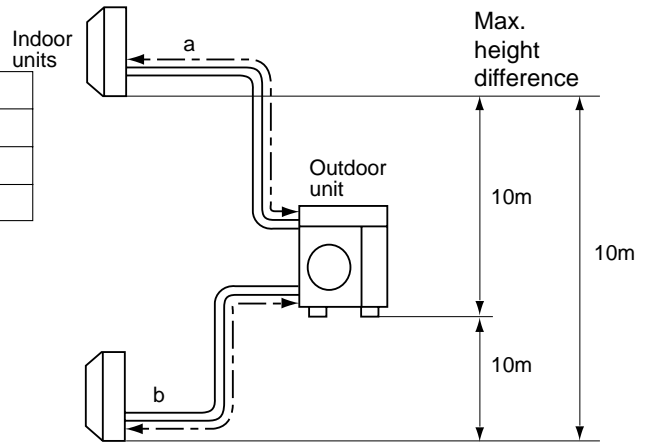

● Refrigerant pipe diameter is different according to indoor unit to be connected. When using extension pipes, refer to the tables below.

UNIT: mm (inch)

Outdoor unit union diameter		
For		
Indoor unit A	Liquid	6.35(1/4)
	Gas	9.52(3/8)
Indoor unit B	Liquid	6.35(1/4)
	Gas	9.52(3/8)

MXZ-2A40VA - E1 MXZ-2A52VA

UNIT: mm

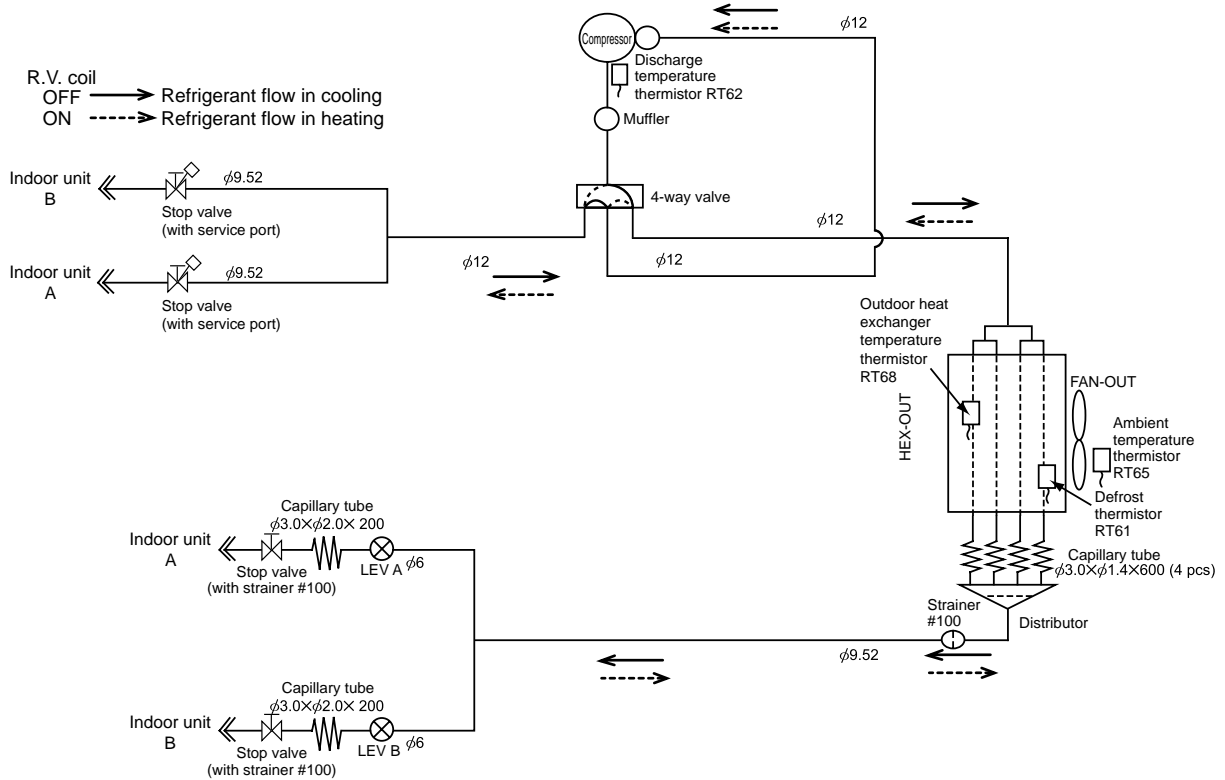

MAX REFRIGERANT PIPING LENGTH

Piping length each indoor unit (a, b)	20m
Total piping length (a+b)	30m
Bending point for each unit	20
Total bending point	30

*It is irrelevant which unit is higher.

ADDITIONAL REFRIGERANT CHARGE

Outdoor unit precharged (g)	Refrigerant piping length (one way, 2 unit total)	
	20m	30m
1,300	0	200

Calculation : $Xg = 20 \text{ g/m} \times (\text{Refrigerant piping length(m)} - 20)$

- Refrigerant pipe diameter is different according to indoor unit to be connected. When using extension pipes, refer to the tables below.

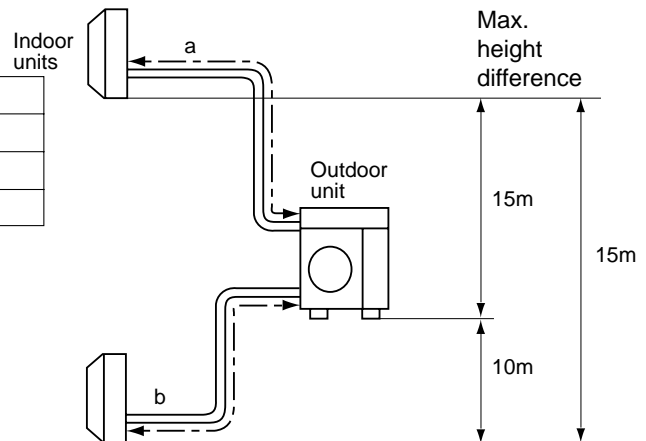

UNIT: mm (inch)

Outdoor unit union diameter		
For		
Indoor unit A	Liquid	6.35(1/4)
	Gas	9.52(3/8)
Indoor unit B	Liquid	6.35(1/4)
	Gas	9.52(3/8)

MXZ-2A40VA - E2

UNIT: mm

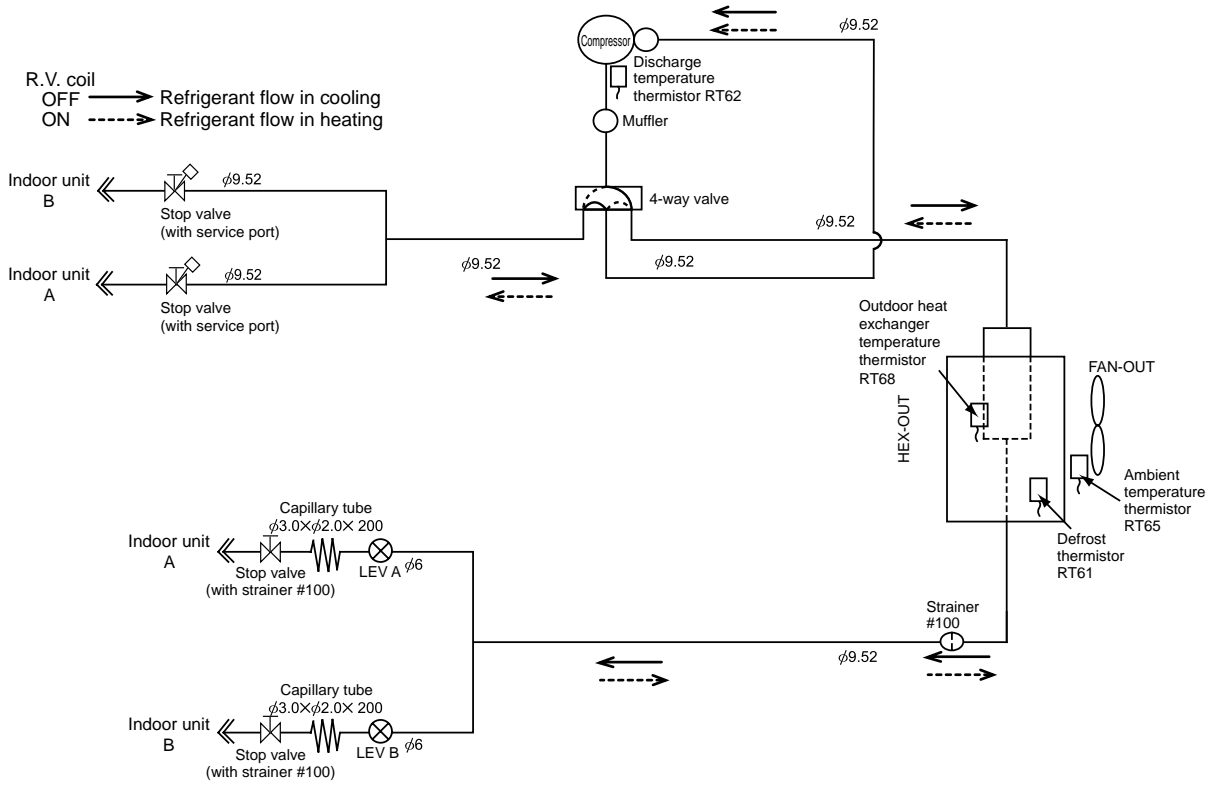

MAX REFRIGERANT PIPING LENGTH

Piping length each indoor unit (a, b)	20m
Total piping length (a+b)	30m
Bending point for each unit	20
Total bending point	30

*It is irrelevant which unit is higher.

ADDITIONAL REFRIGERANT CHARGE

Outdoor unit precharged (g)	Refrigerant piping length (one way, 2 unit total)	
	20m	30m
1,150	0	200

Calculation : $X_g = 20 \text{ g/m} \times (\text{Refrigerant piping length (m)} - 20)$

- Refrigerant pipe diameter is different according to indoor unit to be connected. When using extension pipes, refer to the tables below.

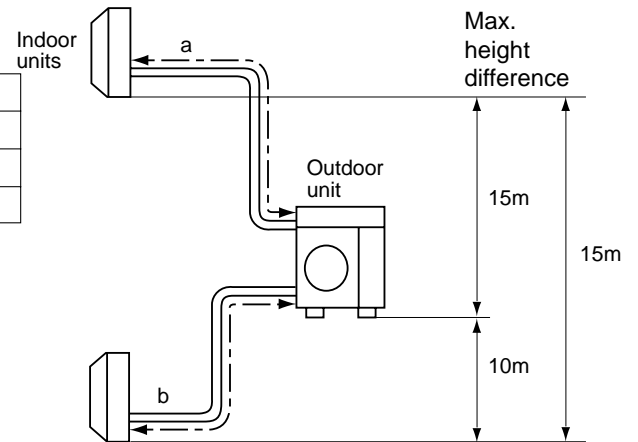

UNIT: mm (inch)

Outdoor unit union diameter		
For		
Indoor unit A	Liquid	6.35(1/4)
	Gas	9.52(3/8)
Indoor unit B	Liquid	6.35(1/4)
	Gas	9.52(3/8)

MXZ-3A54VA - [E1], [E2], [E3], [E4]

UNIT: mm

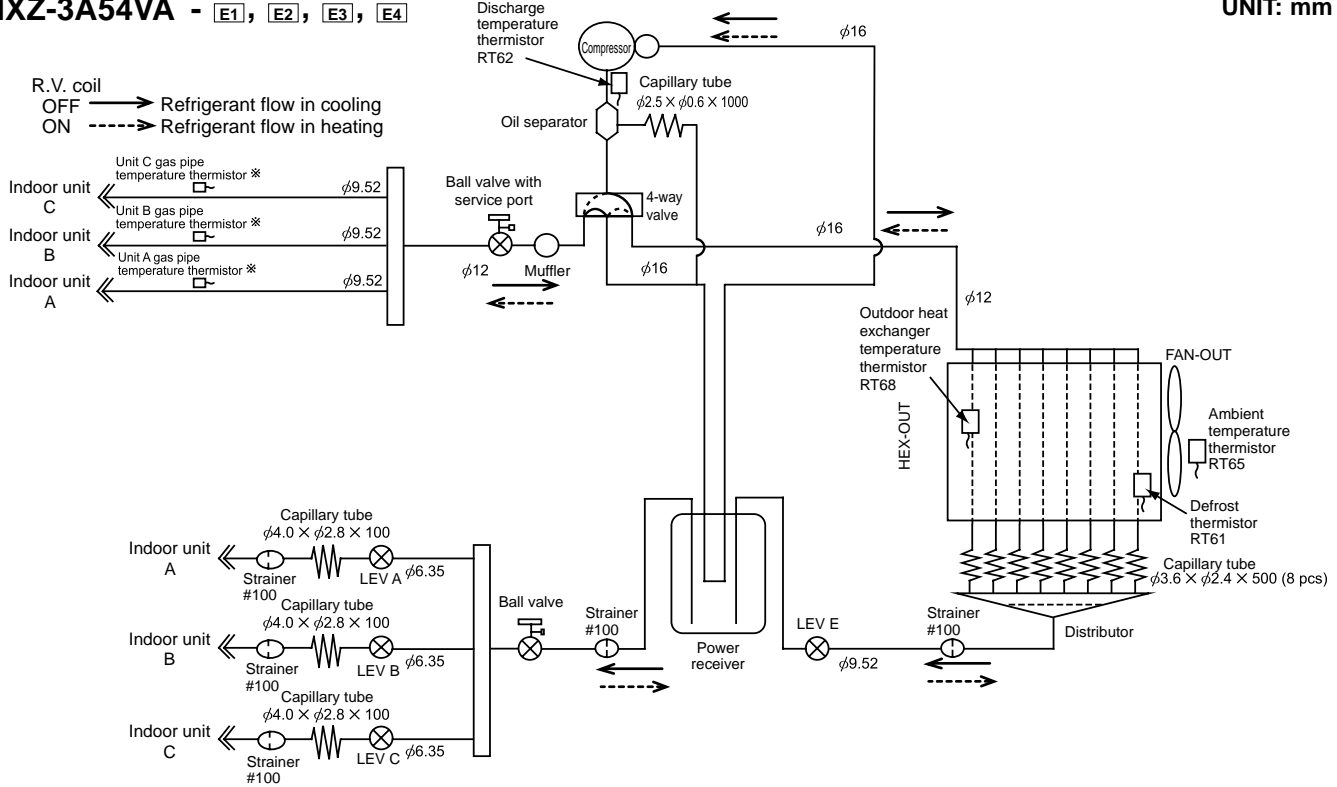

* Except MXZ-3A54VA-[E4]

MAX REFRIGERANT PIPING LENGTH

Piping length each indoor unit (a, b, c)	25m
Total piping length (a+b+c)	50m
Bending point for each unit	25
Total bending point	50

*It is irrelevant which unit is higher.

ADDITIONAL REFRIGERANT CHARGE

Outdoor unit precharged (g)	Refrigerant piping length (one way, 3 unit total)	
	40m	50m
2,700	0	200

Calculation : $Xg = 20 \text{ g/m} \times (\text{Refrigerant piping length (m)} - 40)$

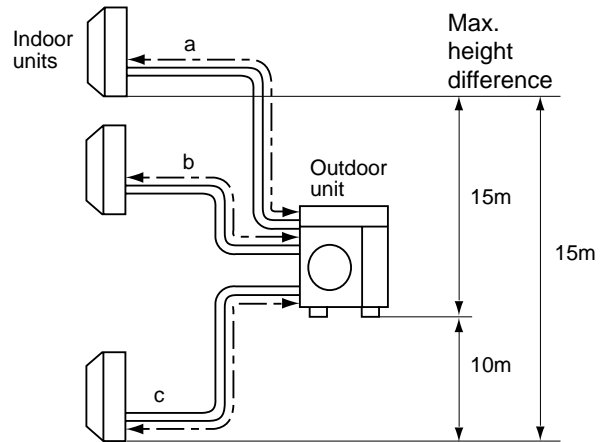

- Refrigerant pipe diameter is different according to indoor unit to be connected. When using extension pipes, refer to the tables below.
- When diameter of refrigerant pipe is different from that of outdoor unit union, use optional Different-diameter pipe. For further information on Different-diameter pipe, see 17-1.

UNIT: mm (inch)

Outdoor unit union diameter		
For		
Indoor unit A	Liquid	6.35(1/4)
	Gas	9.52(3/8)
Indoor unit B	Liquid	6.35(1/4)
	Gas	9.52(3/8)
Indoor unit C	Liquid	6.35(1/4)
	Gas	9.52(3/8)

MXZ-3A54VA - [E5], [E6], [E7]

UNIT: mm

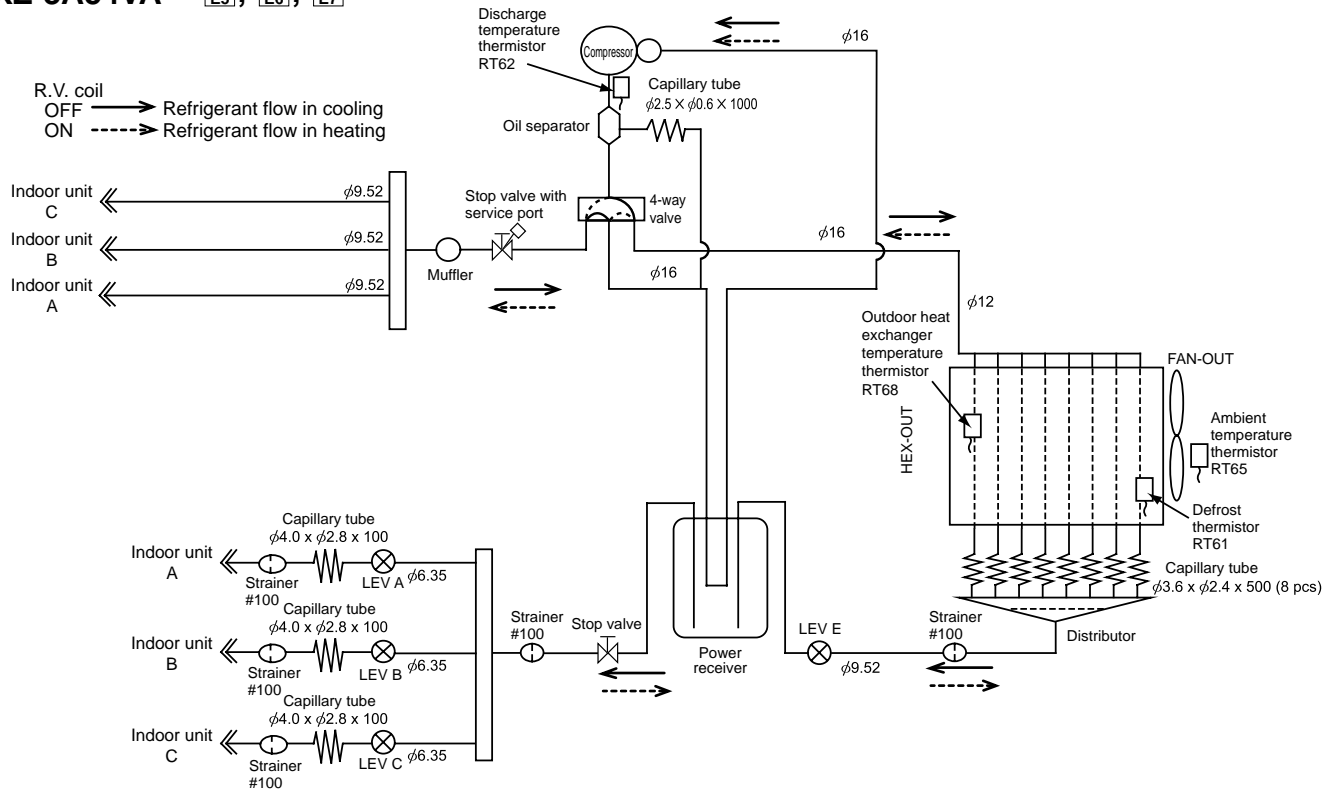

MAX REFRIGERANT PIPING LENGTH

Piping length each indoor unit (a, b, c)	25m
Total piping length (a+b+c)	50m
Bending point for each unit	25
Total bending point	50

*It is irrelevant which unit is higher.

ADDITIONAL REFRIGERANT CHARGE

Outdoor unit precharged (g)	Refrigerant piping length (one way, 3 unit total)	
	40m	50m
2,700	0	200

Calculation : $Xg = 20 \text{ g/m} \times (\text{Refrigerant piping length (m)} - 40)$

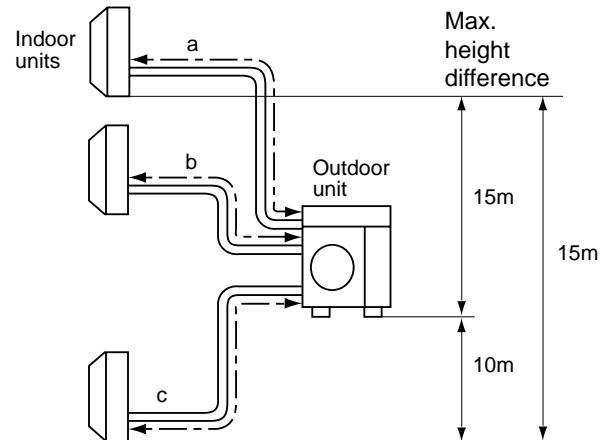

- Refrigerant pipe diameter is different according to indoor unit to be connected. When using extension pipes, refer to the tables below.
- When diameter of refrigerant pipe is different from that of outdoor unit union, use optional Different-diameter pipe. For further information on Different-diameter pipe, see 17-1.

UNIT: mm (inch)

Outdoor unit union diameter		
For		
Indoor unit A	Liquid	6.35(1/4)
	Gas	9.52(3/8)
Indoor unit B	Liquid	6.35(1/4)
	Gas	9.52(3/8)
Indoor unit C	Liquid	6.35(1/4)
	Gas	9.52(3/8)

MXZ-4A71VA - [E1], [E2], [E3], [E4]

UNIT: mm

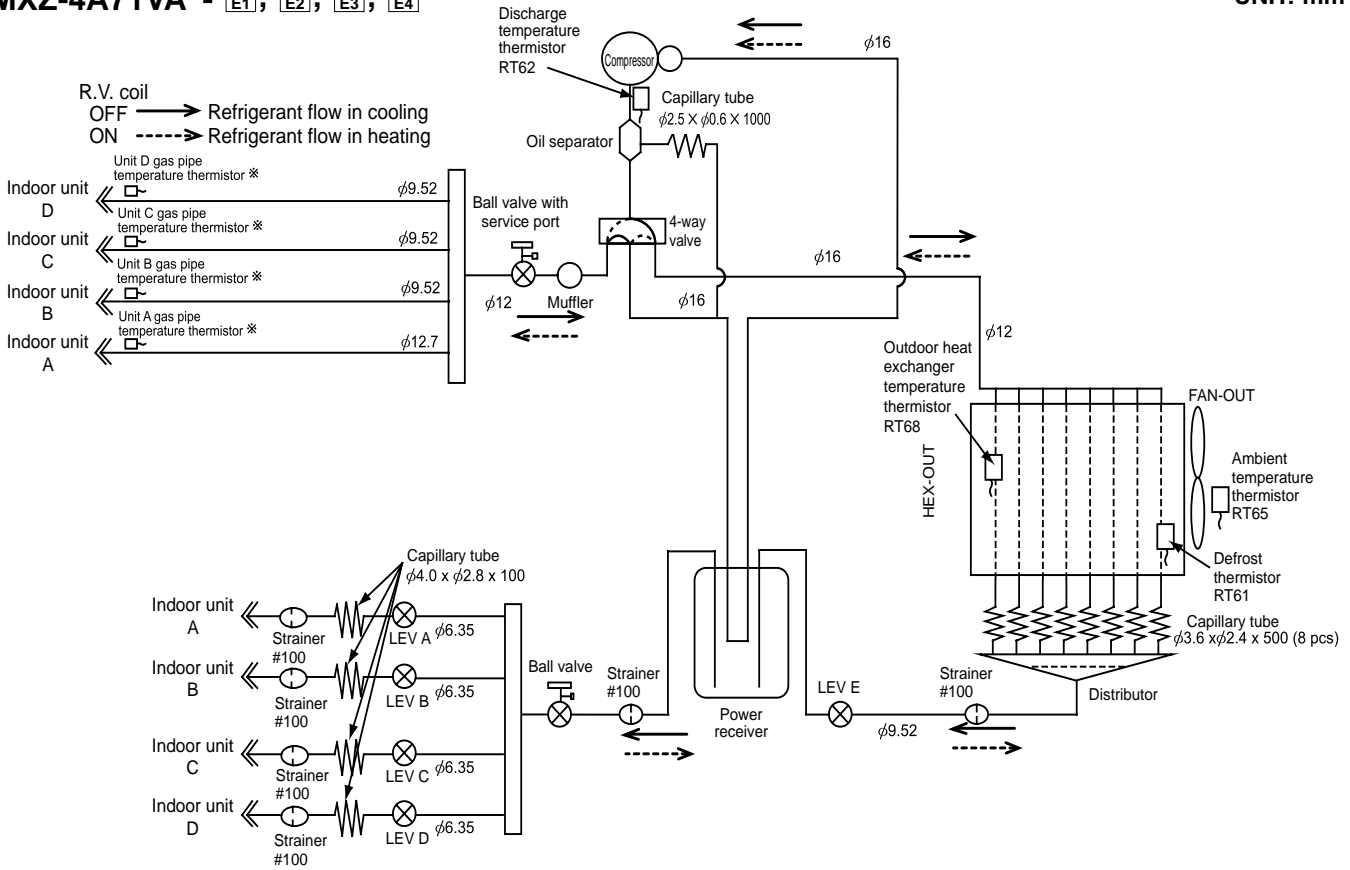

* Except MXZ-4A71VA [E4]

MAX REFRIGERANT PIPING LENGTH

Piping length each indoor unit (a, b, c, d)	25m
Total piping length (a+b+c+d)	60m
Bending point for each unit	25
Total bending point	60

*It is irrelevant which unit is higher.

ADDITIONAL REFRIGERANT CHARGE

Outdoor unit precharged (g)	Refrigerant piping length (one way, 4 unit total)		
	40m	50m	60m
2,700	0	200	400

Calculation : $Xg = 20 \text{ g/m} \times (\text{Refrigerant piping length (m)} - 40)$

- Refrigerant pipe diameter is different according to indoor unit to be connected. When using extension pipes, refer to the tables below.
- When diameter of refrigerant pipe is different from that of outdoor unit union, use optional Different-diameter pipe. For further information on Different-diameter pipe, see 17-1.

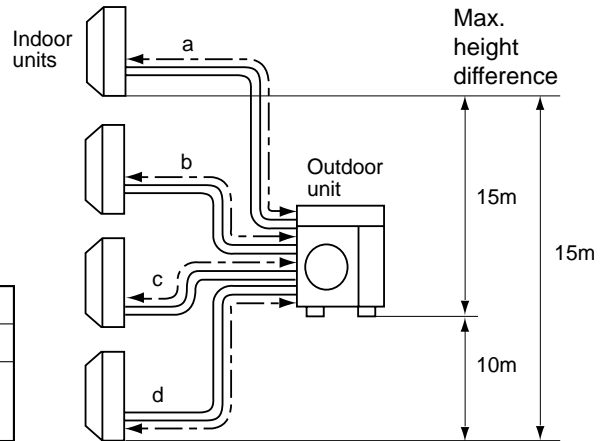

UNIT: mm (inch)

Outdoor unit union diameter		
For		
Indoor unit A	Liquid	6.35(1/4)
	Gas	12.7(1/2)
Indoor unit B	Liquid	6.35(1/4)
	Gas	9.52(3/8)
Indoor unit C	Liquid	6.35(1/4)
	Gas	9.52(3/8)
Indoor unit D	Liquid	6.35(1/4)
	Gas	9.52(3/8)

MXZ-4A71VA - [E5], [E6], [E7]

UNIT: mm

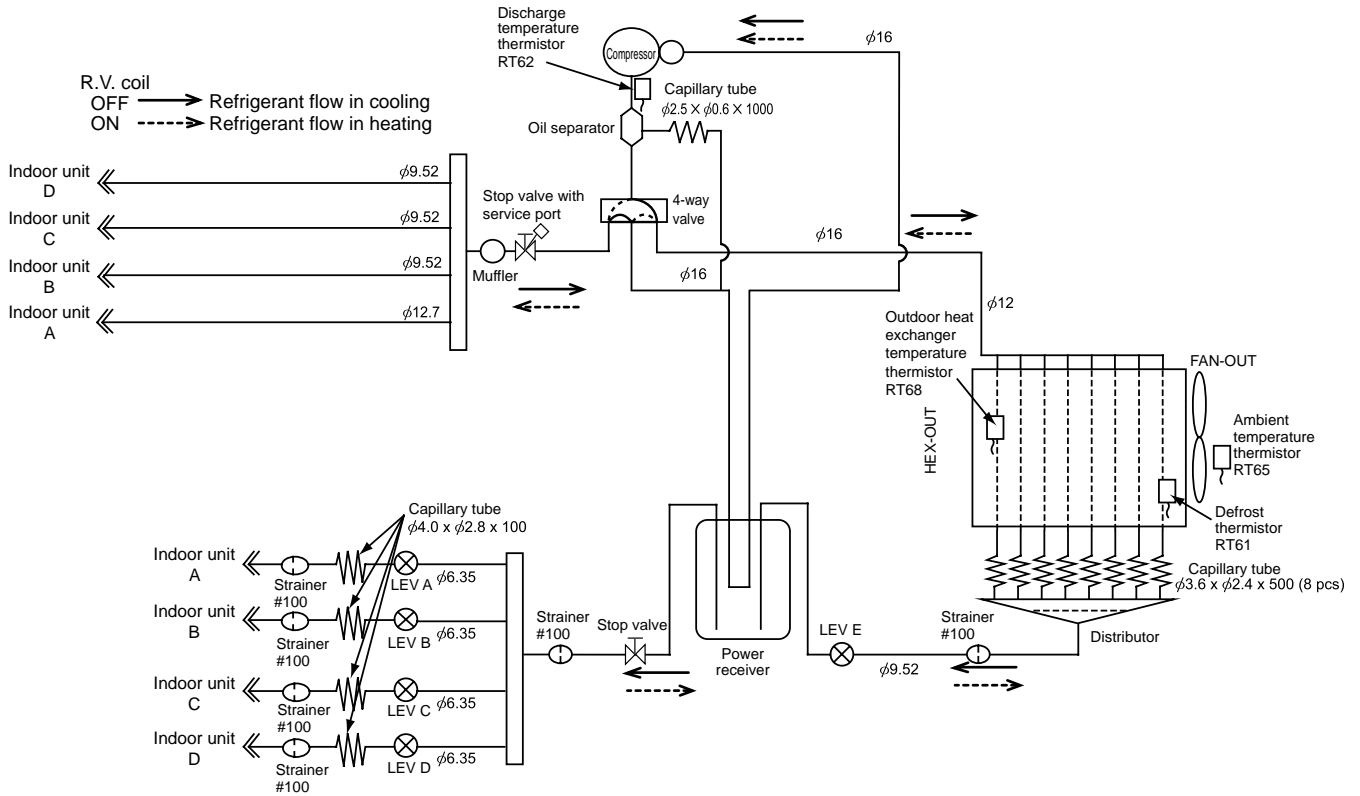

MAX REFRIGERANT PIPING LENGTH

Piping length each indoor unit (a, b, c, d)	25m
Total piping length (a+b+c+d)	60m
Bending point for each unit	25
Total bending point	60

*It is irrelevant which unit is higher.

ADDITIONAL REFRIGERANT CHARGE

Outdoor unit precharged (g)	Refrigerant piping length (one way, 4 unit total)		
	40m	50m	60m
2,700	0	200	400

Calculation : $Xg = 20 \text{ g/m} \times (\text{Refrigerant piping length (m)} - 40)$

- Refrigerant pipe diameter is different according to indoor unit to be connected. When using extension pipes, refer to the tables below.
- When diameter of refrigerant pipe is different from that of outdoor unit union, use optional Different-diameter pipe. For further information on Different-diameter pipe, see 17-1.

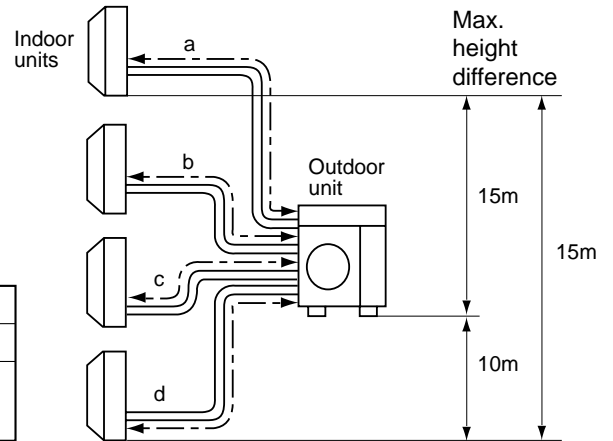

UNIT: mm (inch)

Outdoor unit union diameter		
For		
Indoor unit A	Liquid	6.35(1/4)
	Gas	12.7(1/2)
Indoor unit B	Liquid	6.35(1/4)
	Gas	9.52(3/8)
Indoor unit C	Liquid	6.35(1/4)
	Gas	9.52(3/8)
Indoor unit D	Liquid	6.35(1/4)
	Gas	9.52(3/8)

MXZ-4A80VA - E1

UNIT: mm

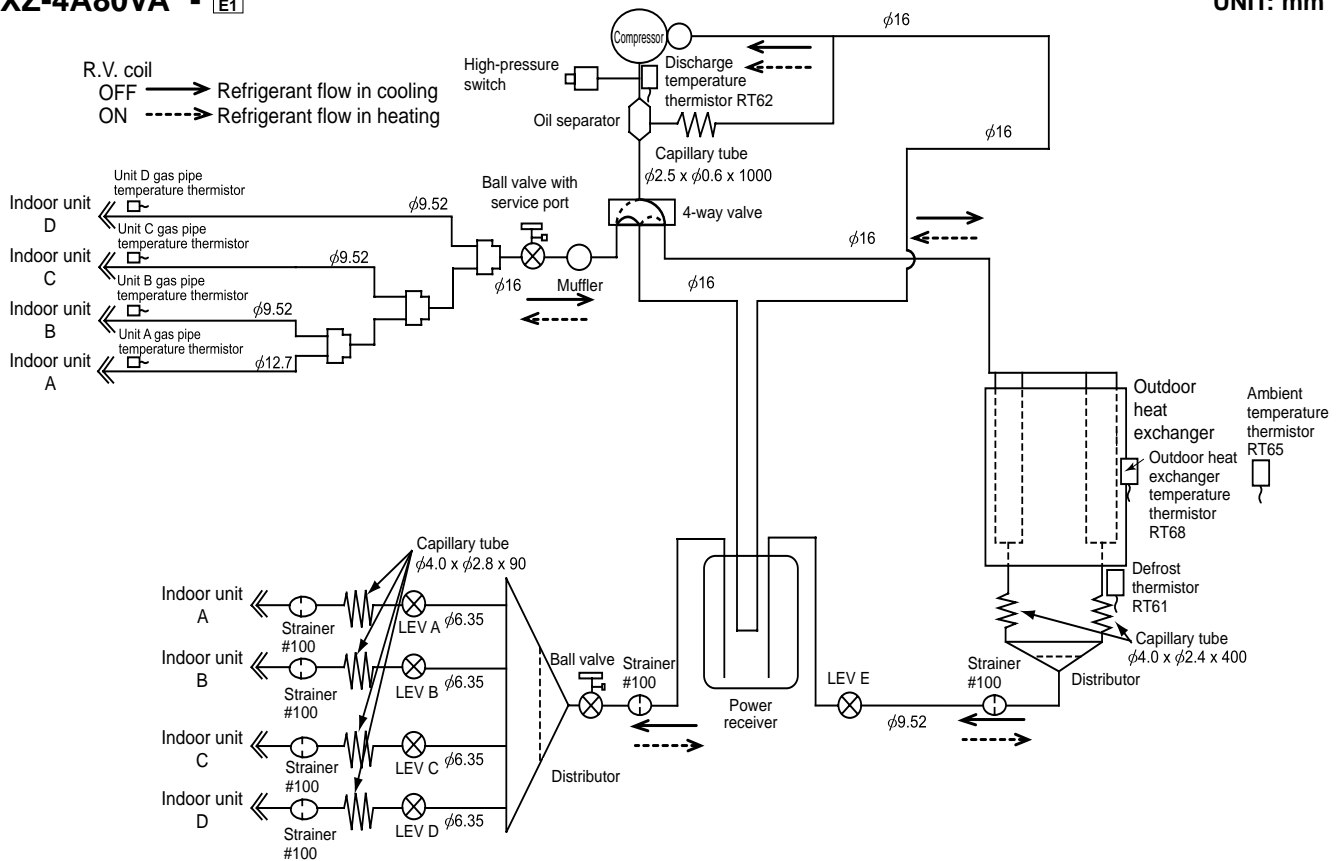

MAX REFRIGERANT PIPING LENGTH

Piping length each indoor unit (a, b, c, d)	25m
Total piping length (a+b+c+d)	70m
Bending point for each unit	25
Total bending point	70

*It is irrelevant which unit is higher.

ADDITIONAL REFRIGERANT CHARGE

Outdoor unit precharged (g)	Refrigerant piping length (one way, 4 unit total)			
	40m	50m	60m	70m
3,500	0	200	400	600

Calculation : $Xg = 20 \text{ g/m} \times (\text{Refrigerant piping length (m)} - 40)$

- Refrigerant pipe diameter is different according to indoor unit to be connected. When using extension pipes, refer to the tables below.
- When diameter of refrigerant pipe is different from that of outdoor unit union, use optional Different-diameter pipe. For further information on Different-diameter pipe, see 17-1.

UNIT: mm (inch)

Outdoor unit union diameter		
For		
Indoor unit A	Liquid	6.35(1/4)
	Gas	12.7(1/2)
Indoor unit B	Liquid	6.35(1/4)
	Gas	9.52(3/8)
Indoor unit C	Liquid	6.35(1/4)
	Gas	9.52(3/8)
Indoor unit D	Liquid	6.35(1/4)
	Gas	9.52(3/8)

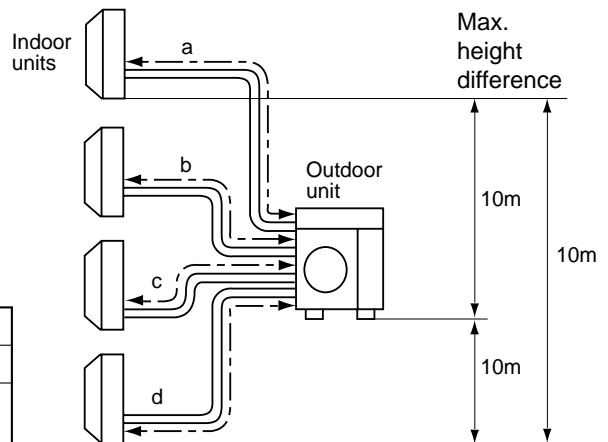

MXZ-4A80VA - E2

UNIT: mm

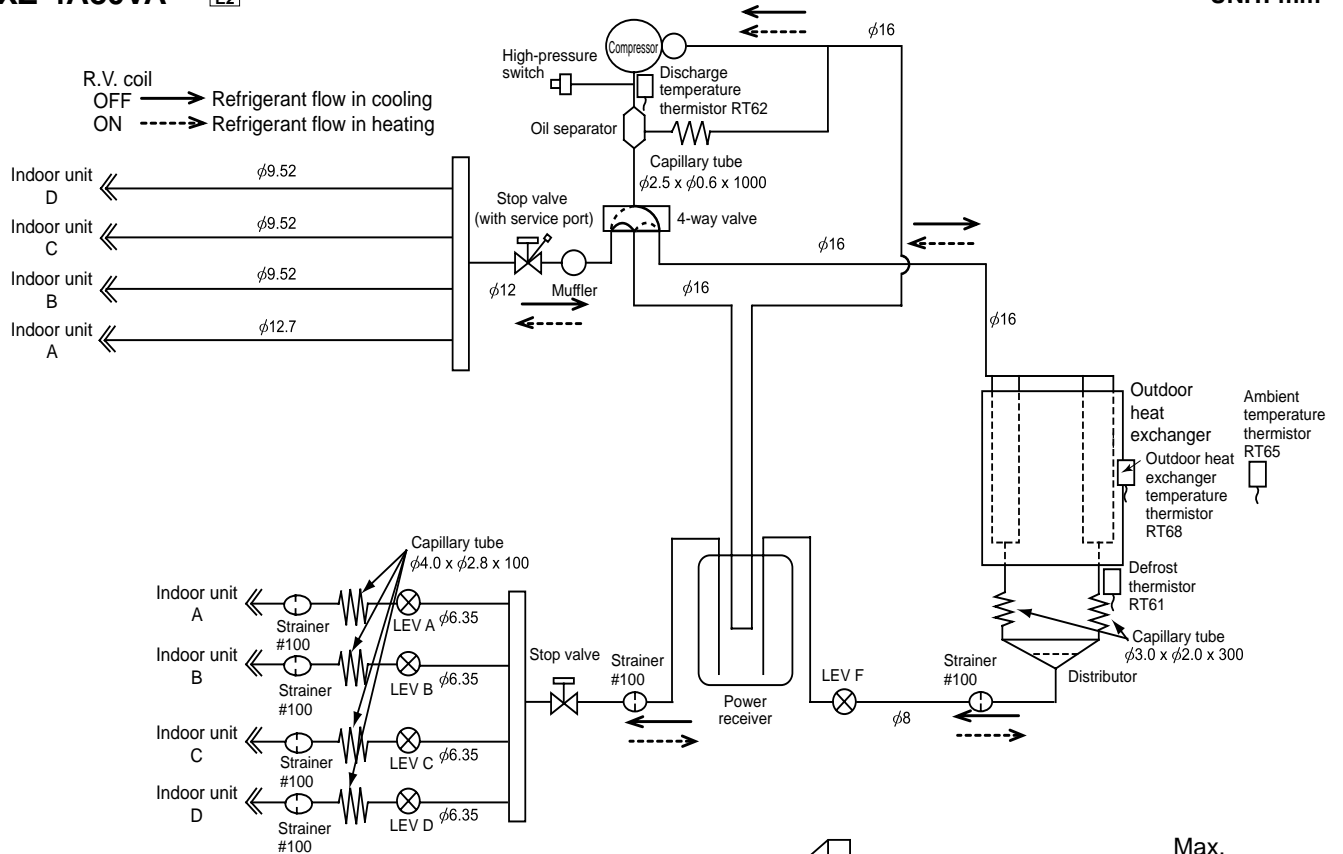

MAX REFRIGERANT PIPING LENGTH

Piping length each indoor unit (a, b, c, d)	25m
Total piping length (a+b+c+d)	70m
Bending point for each unit	25
Total bending point	70

*It is irrelevant which unit is higher.

ADDITIONAL REFRIGERANT CHARGE

Outdoor unit precharged (g)	Refrigerant piping length (one way, 4 unit total)			
	40m	50m	60m	70m
3,500	0	200	400	600

Calculation : $Xg = 20 \text{ g/m} \times (\text{Refrigerant piping length (m)} - 40)$

- Refrigerant pipe diameter is different according to indoor unit to be connected. When using extension pipes, refer to the tables below.
- When diameter of refrigerant pipe is different from that of outdoor unit union, use optional Different-diameter pipe. For further information on Different-diameter pipe, see 17-1.

UNIT: mm (inch)

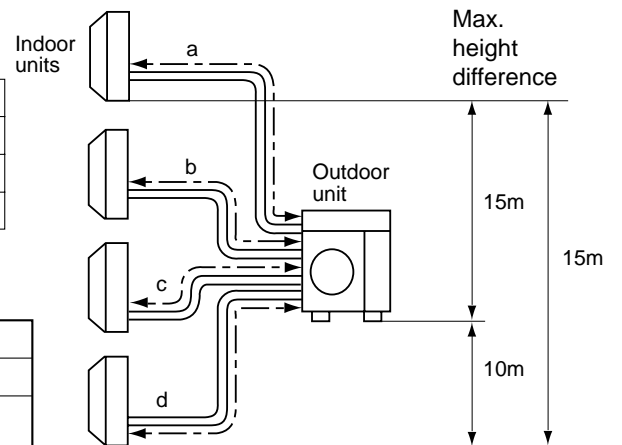

Outdoor unit union diameter		
For		
Indoor unit A	Liquid	6.35(1/4)
	Gas	12.7(1/2)
Indoor unit B	Liquid	6.35(1/4)
	Gas	9.52(3/8)
Indoor unit C	Liquid	6.35(1/4)
	Gas	9.52(3/8)
Indoor unit D	Liquid	6.35(1/4)
	Gas	9.52(3/8)

MXZ-5A100VA

UNIT: mm

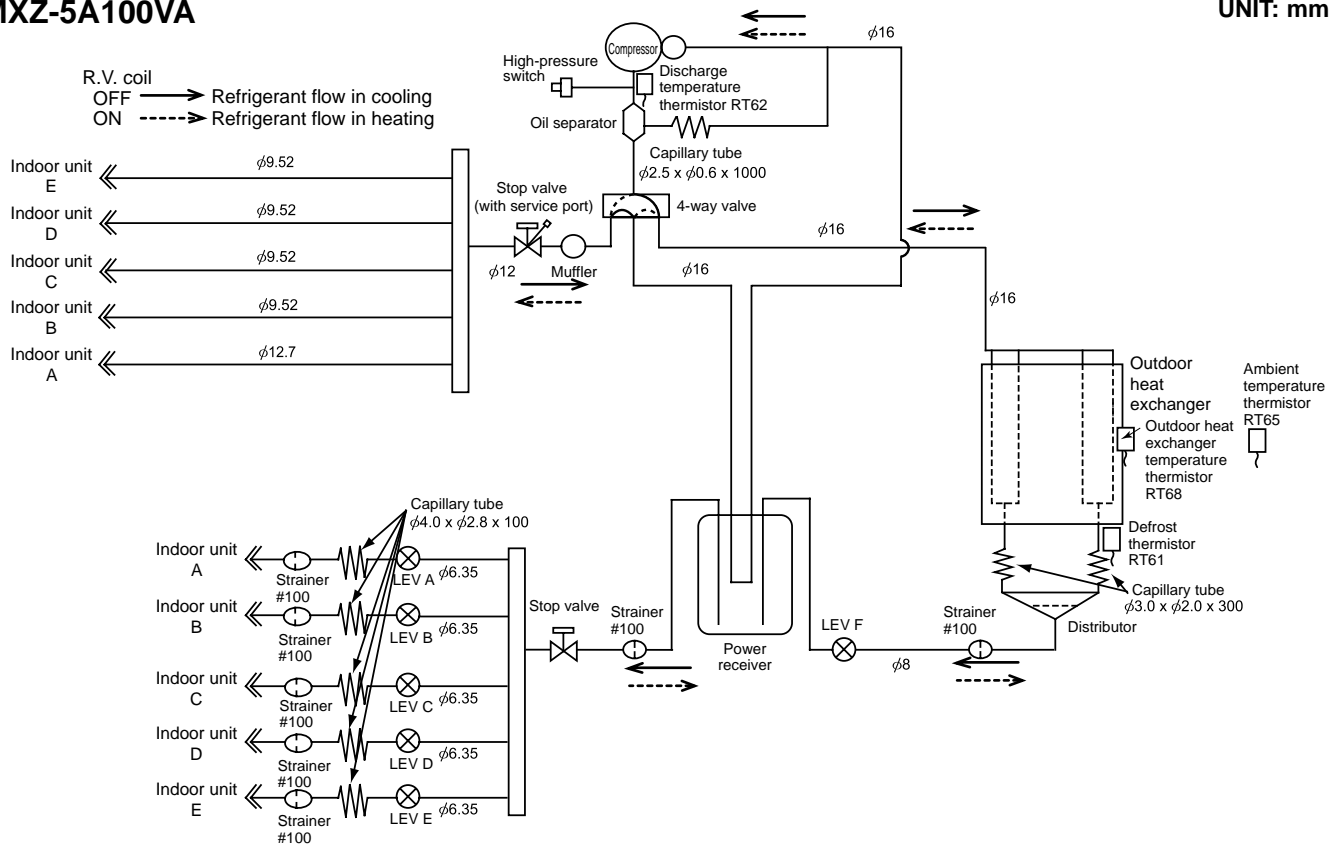

MAX REFRIGERANT PIPING LENGTH

Piping length each indoor unit (a, b, c, d, e)	25m
Total piping length (a+b+c+d+e)	80m
Bending point for each unit	25
Total bending point	80

*It is irrelevant which unit is higher.

ADDITIONAL REFRIGERANT CHARGE

Outdoor unit precharged (g)	Refrigerant piping length (one way, 5 unit total)				
	40m	50m	60m	70m	80m
4,000	0	200	400	600	800

Calculation : $Xg = 20 \text{ g/m} \times (\text{Refrigerant piping length (m)} - 40)$

- Refrigerant pipe diameter is different according to indoor unit to be connected. When using extension pipes, refer to the tables below.
- When diameter of refrigerant pipe is different from that of outdoor unit union, use optional Different-diameter pipe. For further information on Different-diameter pipe, see 17-1.

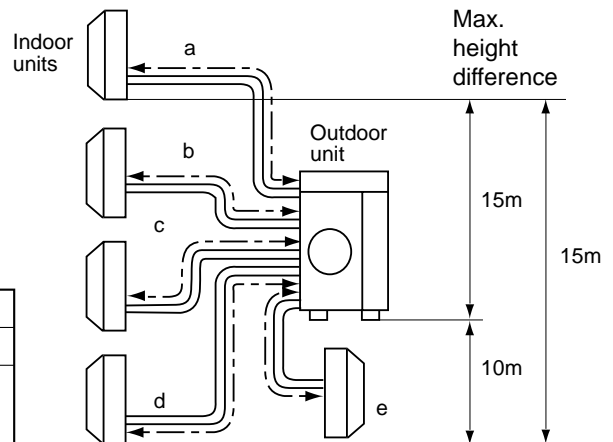

UNIT: mm (inch)

Outdoor unit union diameter		
For		
Indoor unit A	Liquid	6.35(1/4)
	Gas	12.7(1/2)
Indoor unit B	Liquid	6.35(1/4)
	Gas	9.52(3/8)
Indoor unit C	Liquid	6.35(1/4)
	Gas	9.52(3/8)
Indoor unit D	Liquid	6.35(1/4)
	Gas	9.52(3/8)
Indoor unit E	Liquid	6.35(1/4)
	Gas	9.52(3/8)

MXZ-2A30VA MXZ-3A54VA MXZ-5A100VA
MXZ-2A40VA MXZ-4A71VA
MXZ-2A52VA MXZ-4A80VA

The standard specifications apply only to the operation of the air conditioner under normal conditions. Since operating conditions vary according to the areas where these units are installed, the following information has been provided to clarify the operating characteristics of the air conditioner under the conditions indicated by the performance curve.

(1) GUARANTEED VOLTAGE

198~264 V 50 Hz

(2) AIR FLOW

Air flow should be set at MAX.

(3) MAIN READINGS

(1) Indoor intake air wet-bulb temperature :	°CWB	} Cooling
(2) Indoor outlet air wet-bulb temperature :	°CWB	
(3) Outdoor intake air dry-bulb temperature :	°CDB	
(4) Total input:	W	} Heating
(5) Indoor intake air dry-bulb temperature :	°CDB	
(6) Outdoor intake air wet-bulb temperature :	°CWB	
(7) Total input :	W	

Indoor air wet and dry bulb temperature difference on the left side of the following chart shows the difference between the indoor intake air wet and dry bulb temperature and the indoor outlet air wet and dry bulb temperature for your reference at service.

How to measure the indoor air wet and dry bulb temperature difference

1. Attach at least 2 sets of wet and dry bulb thermometers to the indoor air intake as shown in the figure, and at least 2 sets of wet and dry bulb thermometers to the indoor air outlet. The thermometers must be attached to the position where air speed is high.
2. Attach at least 2 sets of wet and dry bulb thermometers to the outdoor air intake. Cover the thermometers to prevent direct rays of the sun.
3. Check that the air filter is cleaned.
4. Open windows and doors of room.
5. Press the EMERGENCY OPERATION switch once (twice) to start the EMERGENCY COOL (HEAT) MODE.
6. When system stabilizes after more than 15 minutes, measure temperature and take an average temperature.
7. 10 minutes later, measure temperature again and check that the temperature does not change.

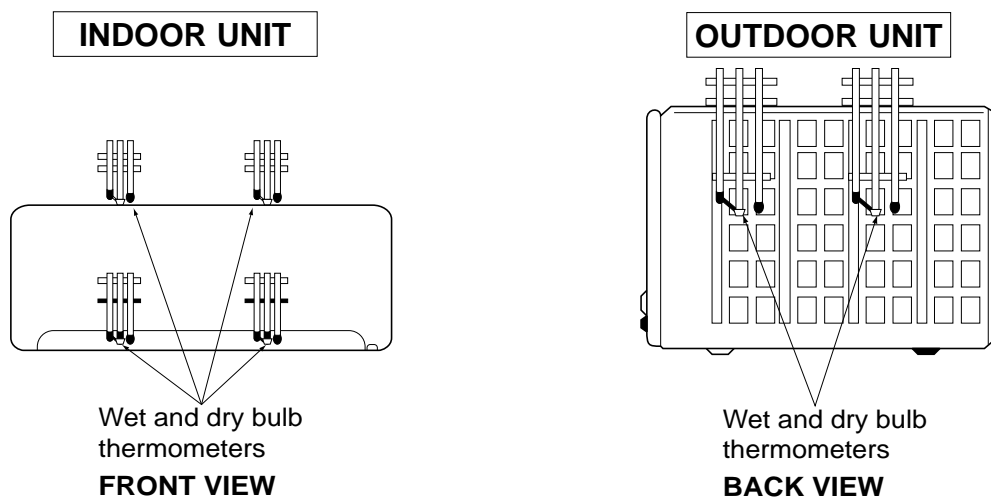

10-1. CAPACITY AND THE INPUT CURVES

MXZ-2A30VA

MXZ-2A40VA

MXZ-2A52VA

8.5	9.3	10.6
7.8	8.5	9.7
7.1	7.8	8.8
6.4	7.0	7.9
5.8	6.3	7.1
5.1	5.6	6.3
22 class	25 class	35 class

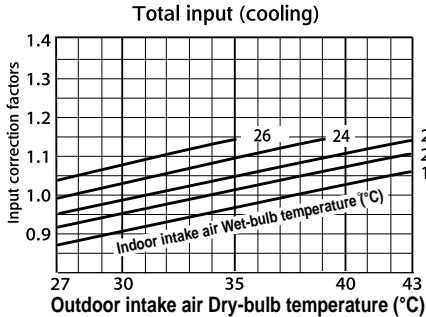
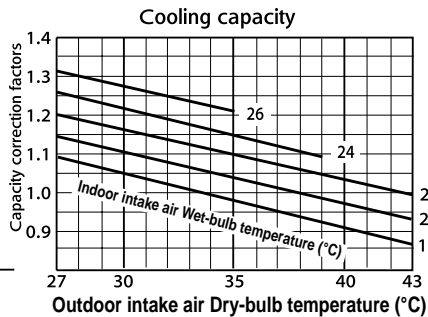

25.4	24.0	25.9
23.4	22.2	23.9
21.5	20.3	21.9
19.5	18.5	19.9
17.6	16.6	17.9
15.6	14.8	15.9
13.7	12.9	13.9
11.7	11.1	12.0
22 class	25 class	35 class

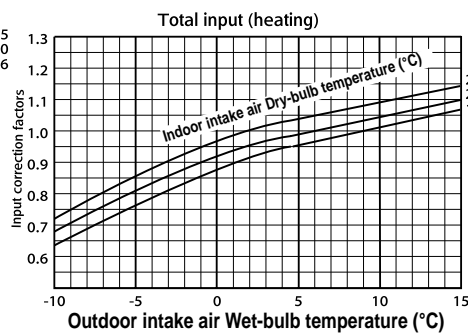
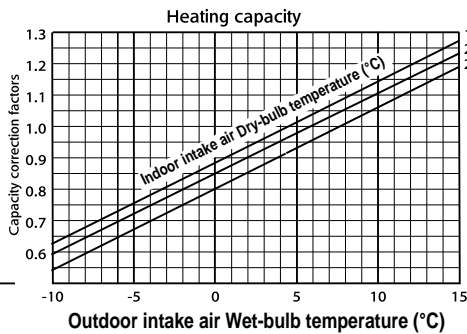

MXZ-3A54VA

MXZ-4A71VA

8.5	9.3	10.6	9.5	13.1	13.7
7.8	8.5	9.7	8.7	11.9	12.4
7.1	7.8	8.8	8.0	10.8	11.3
6.4	7.0	7.9	7.2	9.7	10.1
5.8	6.3	7.1	6.5	8.7	9.0
5.1	5.6	6.3	5.7	7.7	8.0
22 class	25 class	35 class	42 class	50 class	60 class

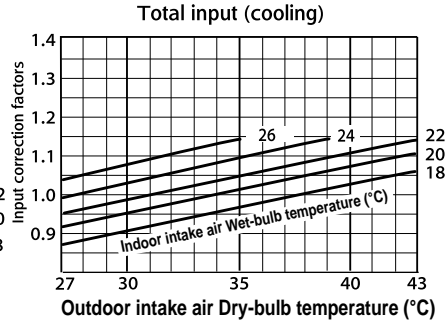
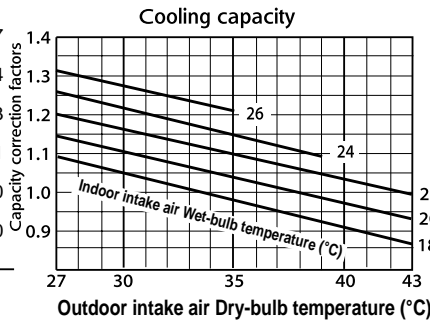

25.4	24.0	25.9	27.0	31.4	31.9
23.4	22.2	23.9	24.9	29.0	29.4
21.5	20.3	21.9	22.8	26.6	27.0
19.5	18.5	19.9	20.7	24.1	24.5
17.6	16.6	17.9	18.7	21.7	22.1
15.6	14.8	15.9	16.6	19.3	19.6
13.7	12.9	13.9	14.5	16.9	17.2
11.7	11.1	12.0	12.4	14.5	14.7
22 class	25 class	35 class	42 class	50 class	60 class

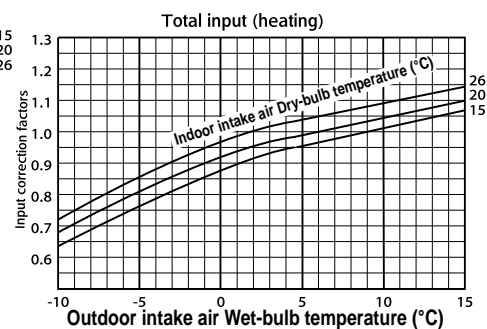
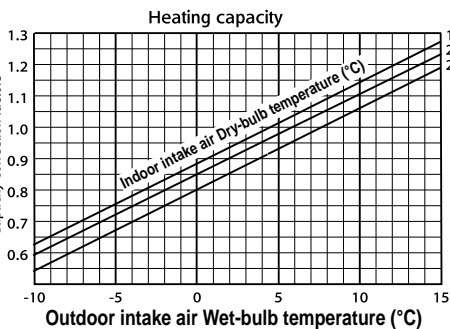

MXZ-4A80VA

8.5	9.3	10.6	9.5	13.1	13.7	17.0
7.8	8.5	9.7	8.7	11.9	12.4	15.4
7.1	7.8	8.8	8.0	10.8	11.3	13.9
6.4	7.0	7.9	7.2	9.7	10.1	12.5
5.8	6.3	7.1	6.5	8.7	9.0	11.1
5.1	5.6	6.3	5.7	7.7	8.0	9.7
22 class	25 class	35 class	42 class	50 class	60 class	71 class

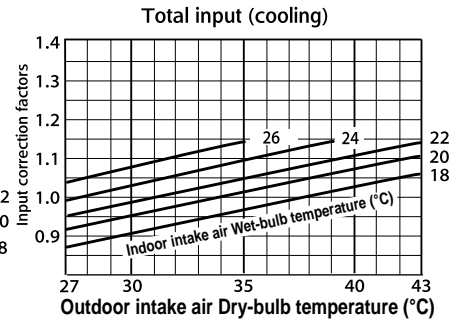
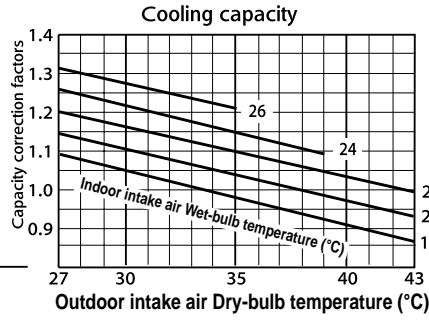

25.4	24.0	25.9	27.0	31.4	31.9	35.1
23.4	22.2	23.9	24.9	29.0	29.4	32.4
21.5	20.3	21.9	22.8	26.6	27.0	29.7
19.5	18.5	19.9	20.7	24.1	24.5	27.0
17.6	16.6	17.9	18.7	21.7	22.1	24.3
15.6	14.8	15.9	16.6	19.3	19.6	21.6
13.7	12.9	13.9	14.5	16.9	17.2	18.9
11.7	11.1	12.0	12.4	14.5	14.7	16.2
22 class	25 class	35 class	42 class	50 class	60 class	71 class

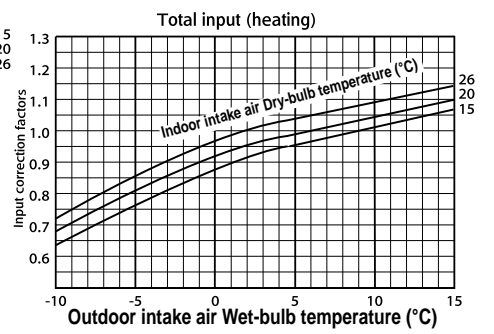
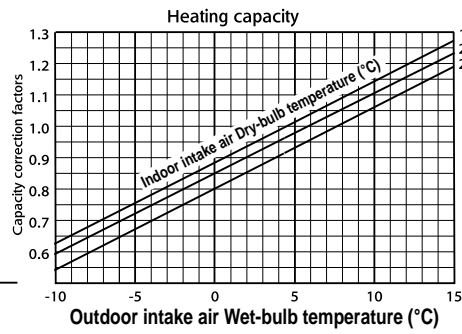

MXZ-5A100VA

8.5	9.3	10.6	9.5	13.1	13.7	17.0
7.8	8.5	9.7	8.7	11.9	12.4	15.4
7.1	7.8	8.8	8.0	10.8	11.3	13.9
6.4	7.0	7.9	7.2	9.7	10.1	12.5
5.8	6.3	7.1	6.5	8.7	9.0	11.1
5.1	5.6	6.3	5.7	7.7	8.0	9.7
22 class	25 class	35 class	42 class	50 class	60 class	71 class

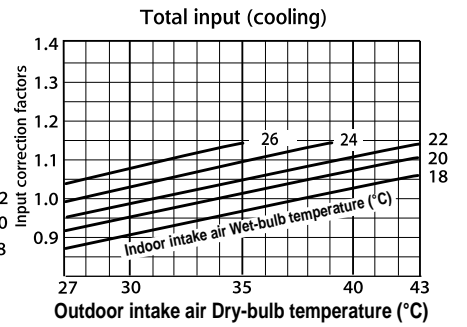
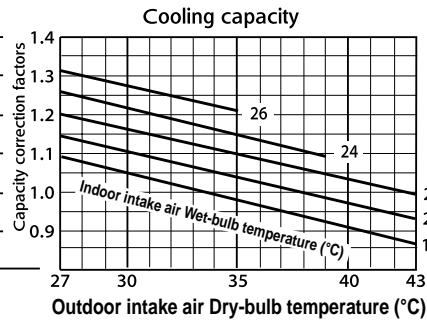

25.4	24.0	25.9	27.0	31.4	31.9	35.1
23.4	22.2	23.9	24.9	29.0	29.4	32.4
21.5	20.3	21.9	22.8	26.6	27.0	29.7
19.5	18.5	19.9	20.7	24.1	24.5	27.0
17.6	16.6	17.9	18.7	21.7	22.1	24.3
15.6	14.8	15.9	16.6	19.3	19.6	21.6
13.7	12.9	13.9	14.5	16.9	17.2	18.9
11.7	11.1	12.0	12.4	14.5	14.7	16.2
22 class	25 class	35 class	42 class	50 class	60 class	71 class

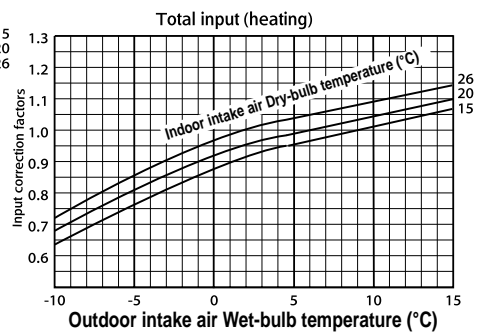
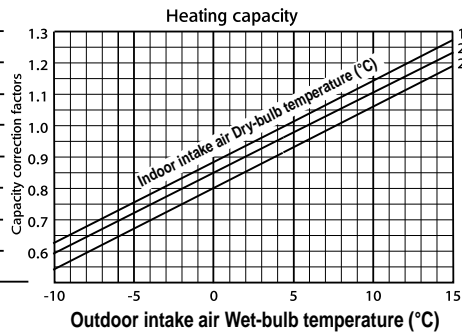

10-2. CAPACITY AND INPUT CORRECTION BY INVERTER OUTPUT FREQUENCY (OUTDOOR UNIT: MXZ-2A30VA/2A40VA - E2)

1. 22-class unit in single operation

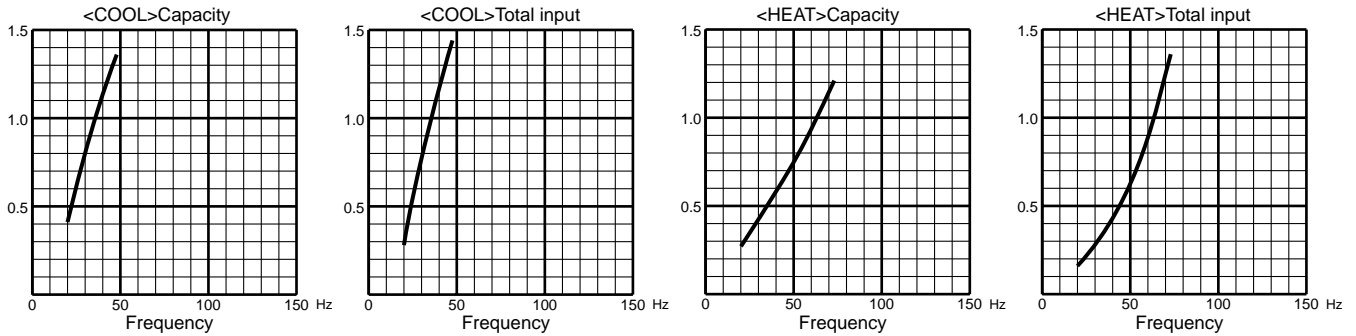

2. 25-class unit in single operation

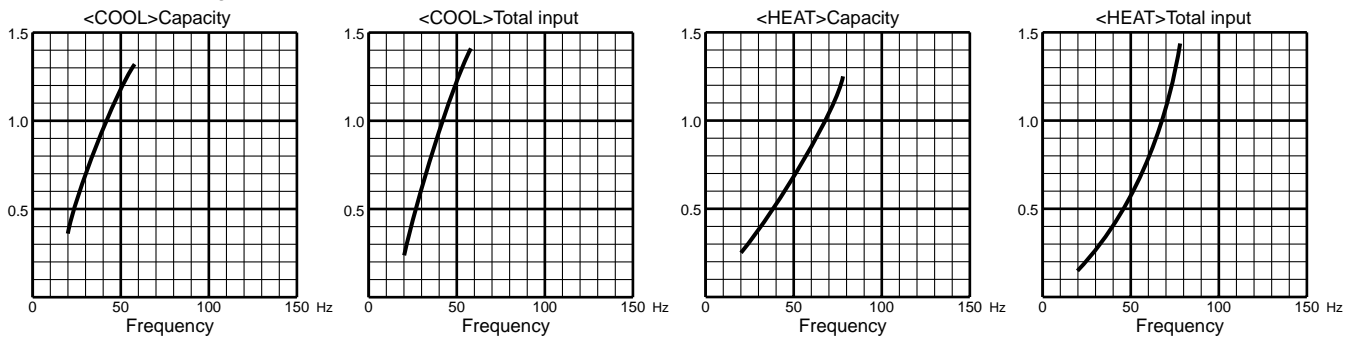

(OUTDOOR UNIT: MXZ-2A40VA - E2)

3. 35-class unit in single operation

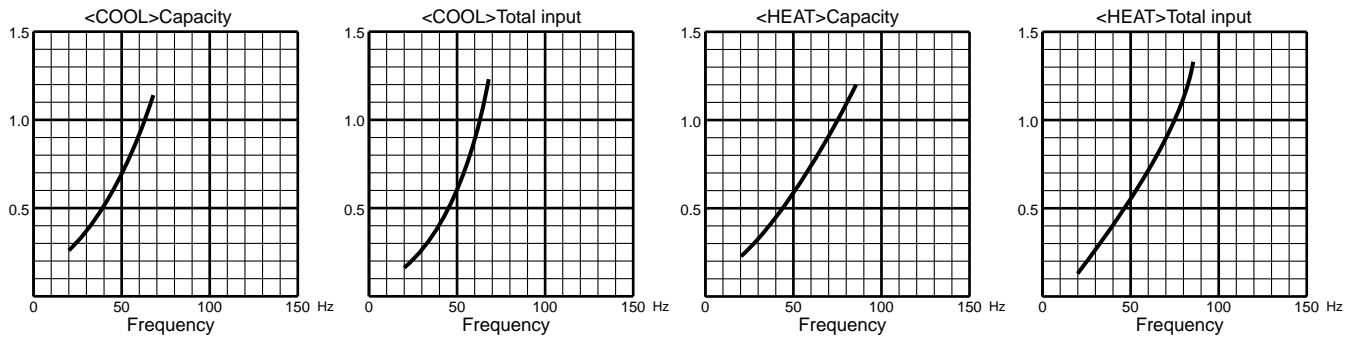

(OUTDOOR UNIT: MXZ-2A40VA - E1 , MXZ-2A52VA)

1. 22-class unit in single operation

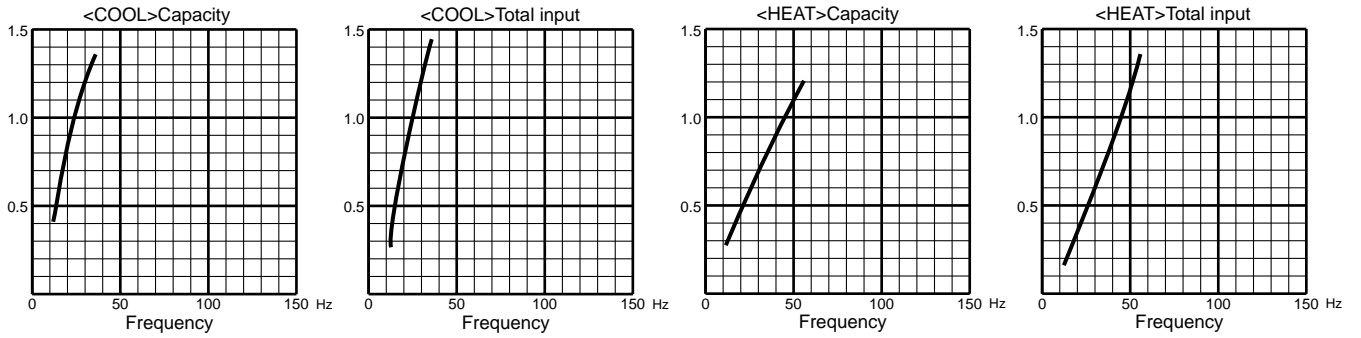

2. 25-class unit in single operation

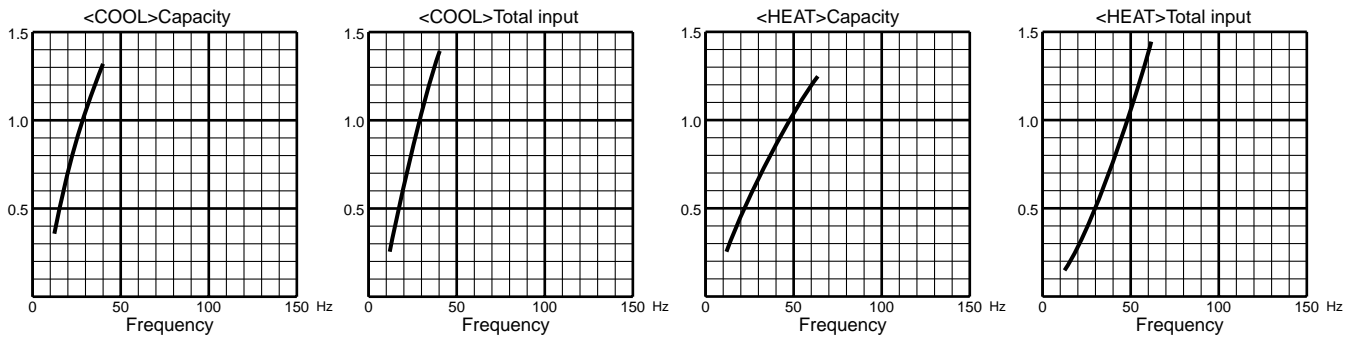

3. 35-class unit in single operation

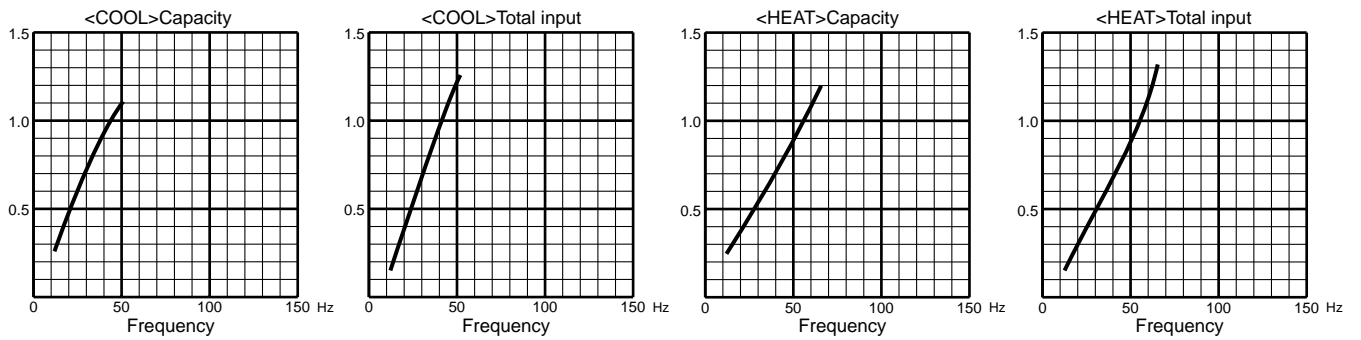

(OUTDOOR UNIT: MXZ-3A54VA)

1. 22-class unit in single operation

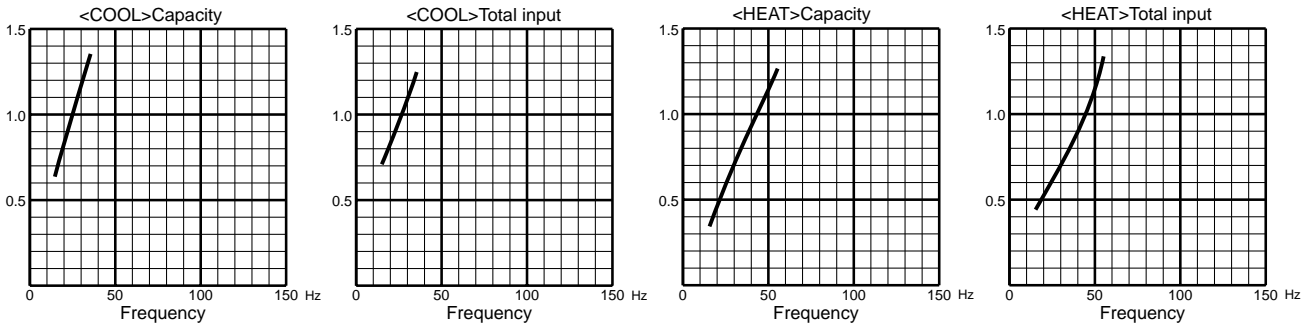

2. 25-class unit in single operation

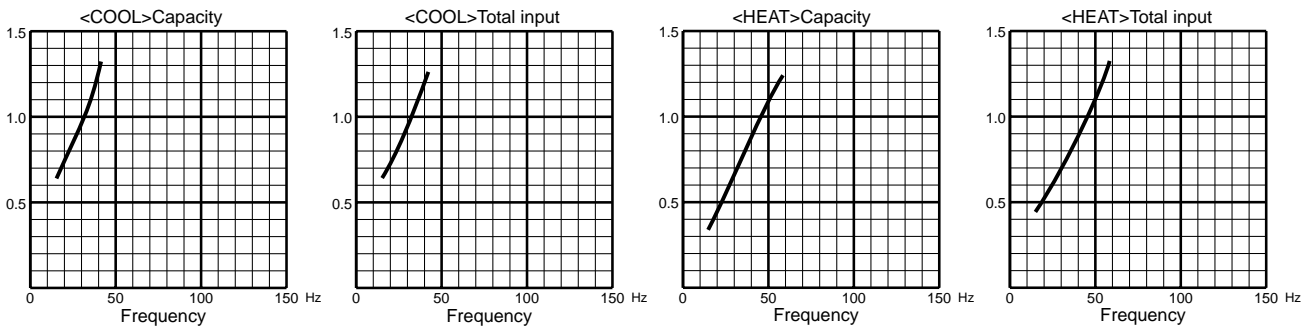

3. 35-class unit in single operation

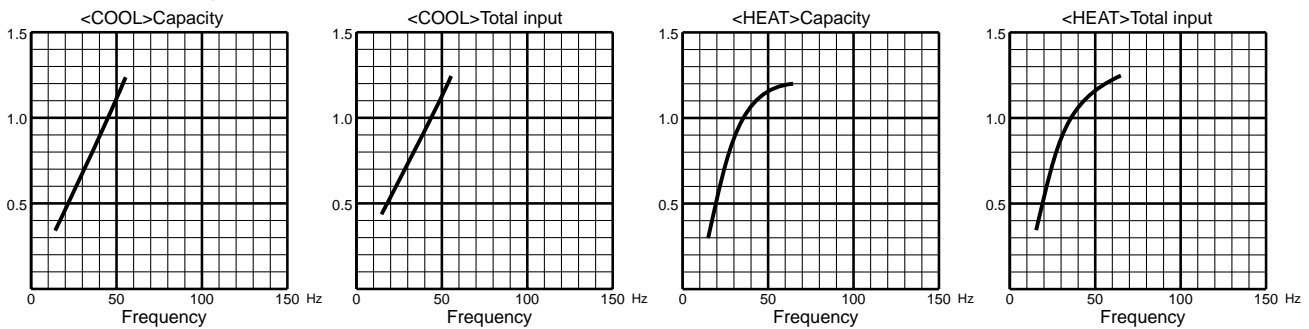

4. 42-class unit in single operation

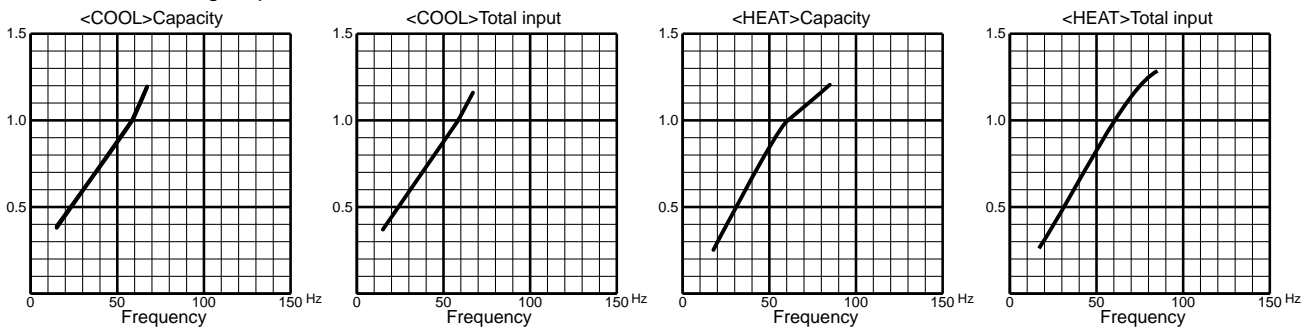

5. 50-class unit in single operation

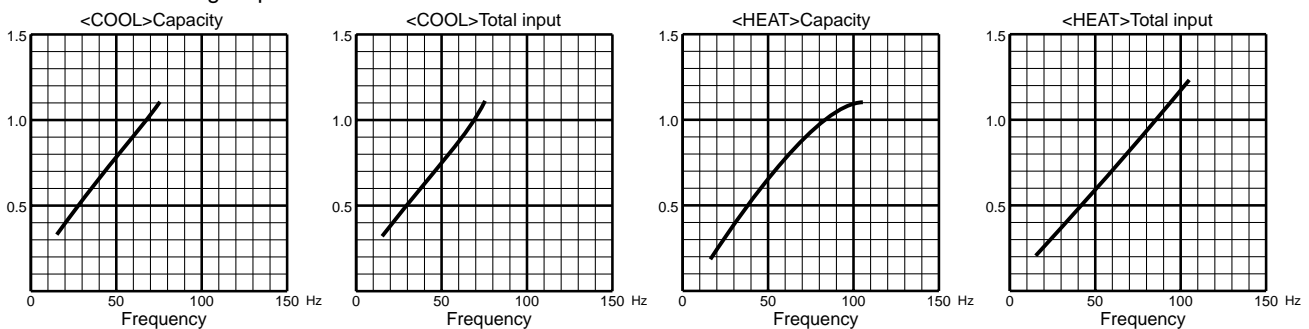

(OUTDOOR UNIT: MXZ-4A71VA)

1. 22-class unit in single operation

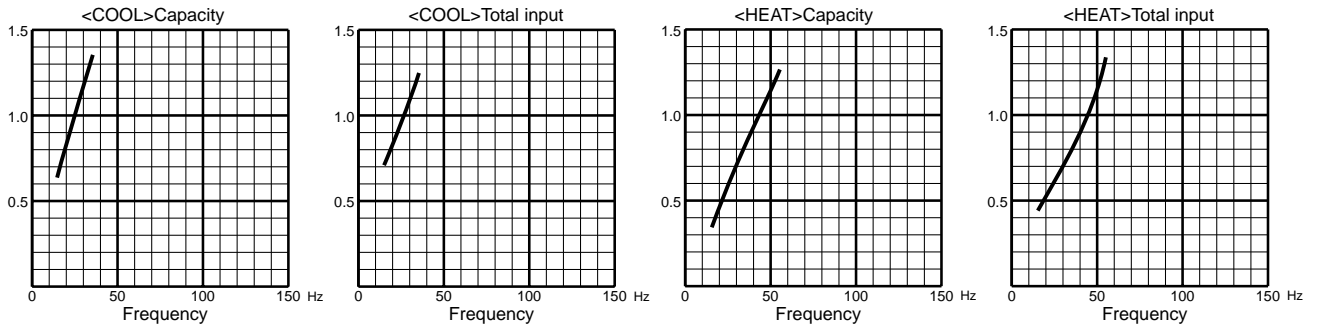

2. 25-class unit in single operation

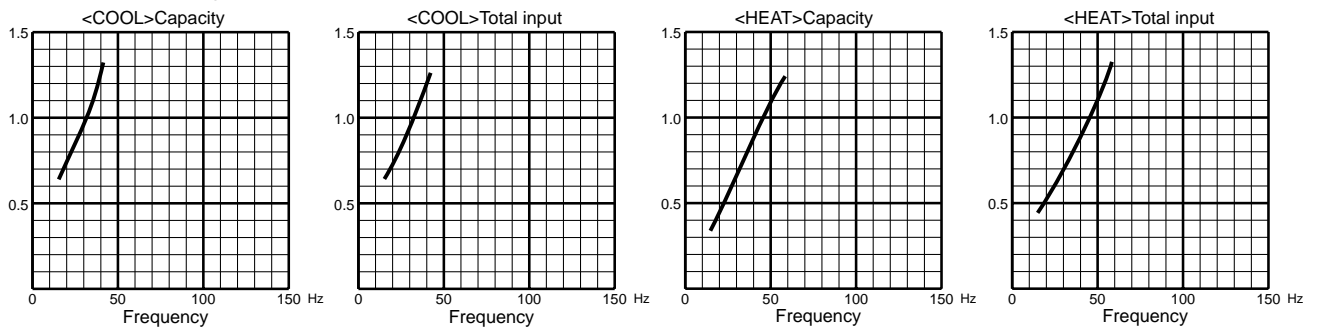

3. 35-class unit in single operation

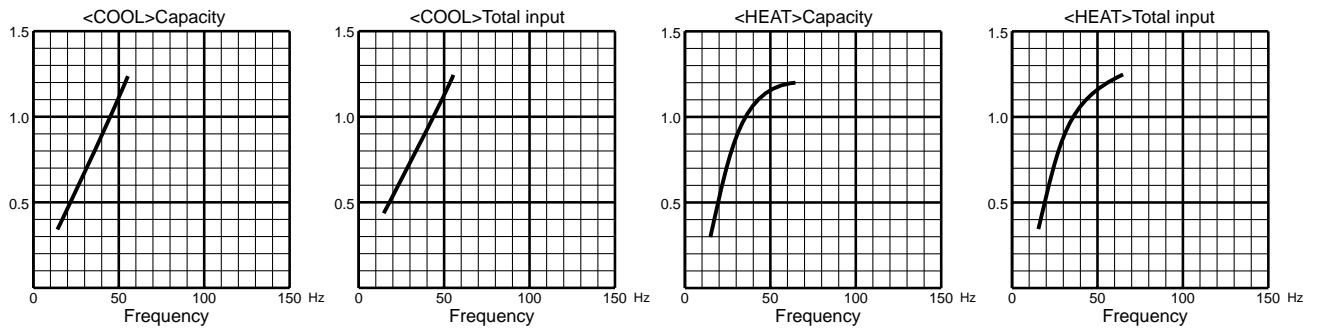

(OUTDOOR UNIT: MXZ-4A71VA)

4. 42-class unit in single operation

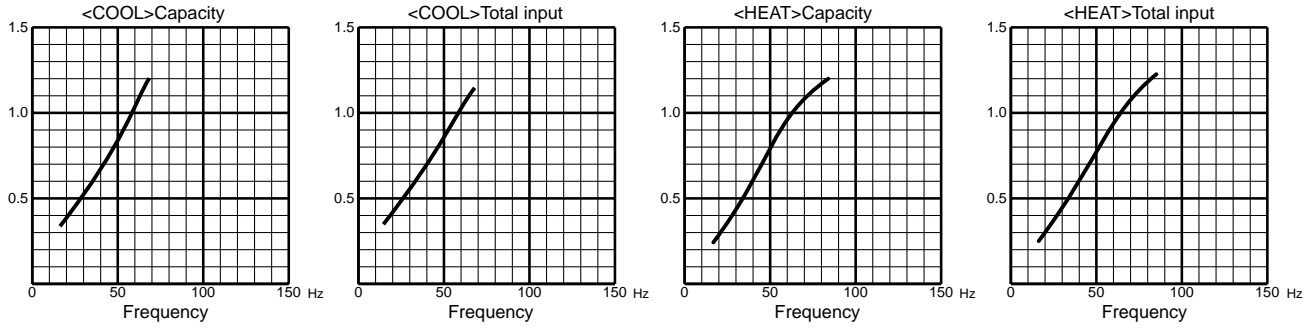

5. 50-class unit in single operation

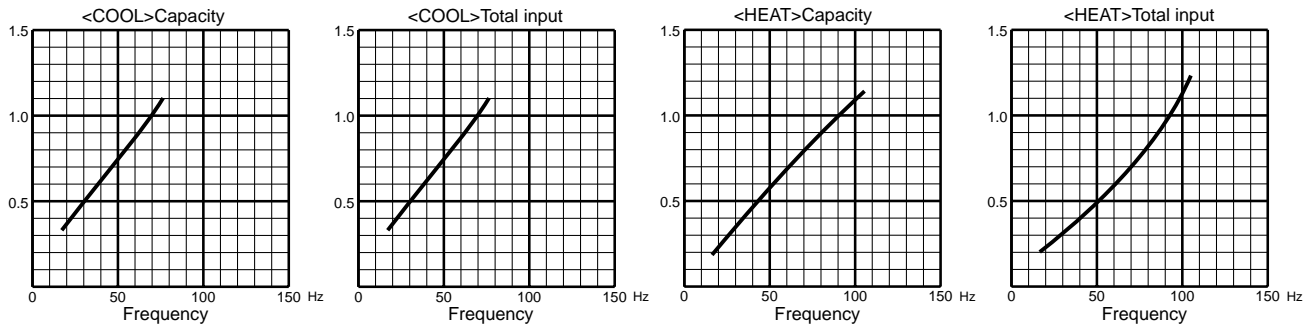

6. 60-class unit in single operation

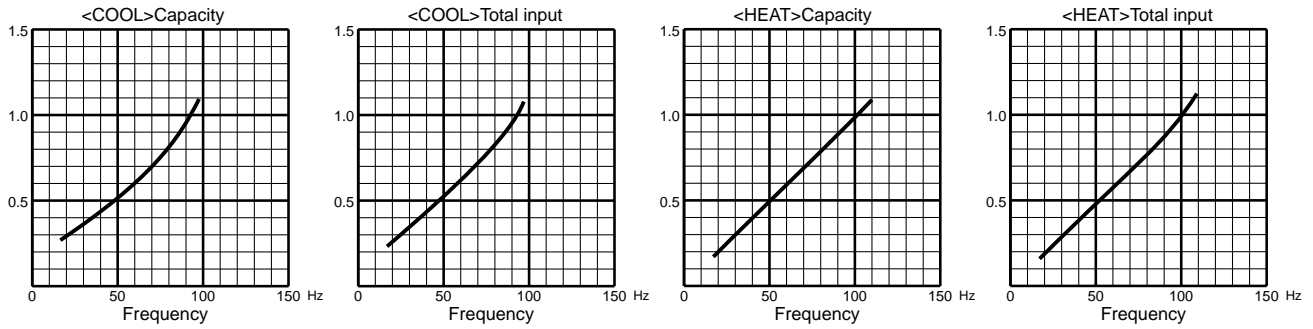

(OUTDOOR UNIT: MXZ-4A80VA)

1. 22-class unit in single operation

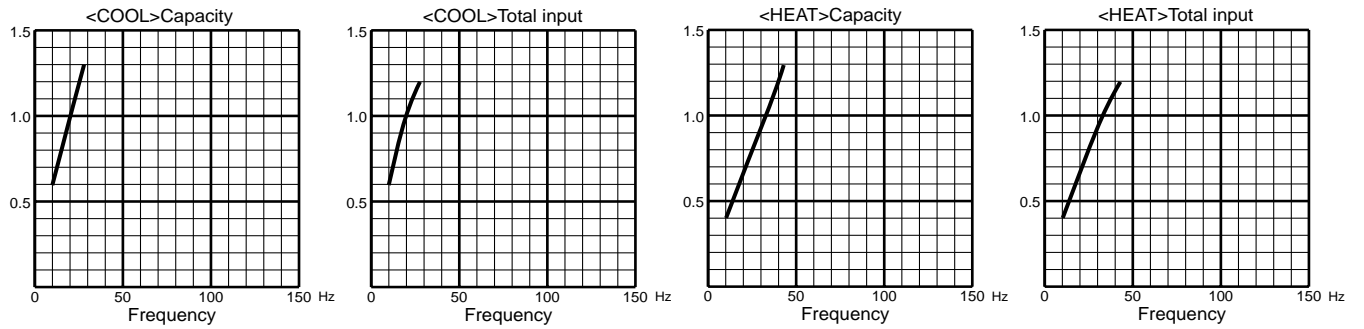

2. 25-class unit in single operation

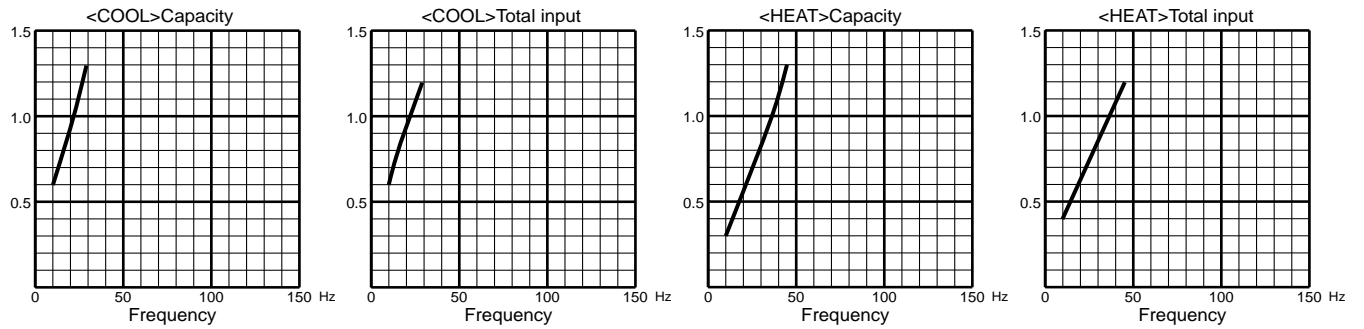

3. 35-class unit in single operation

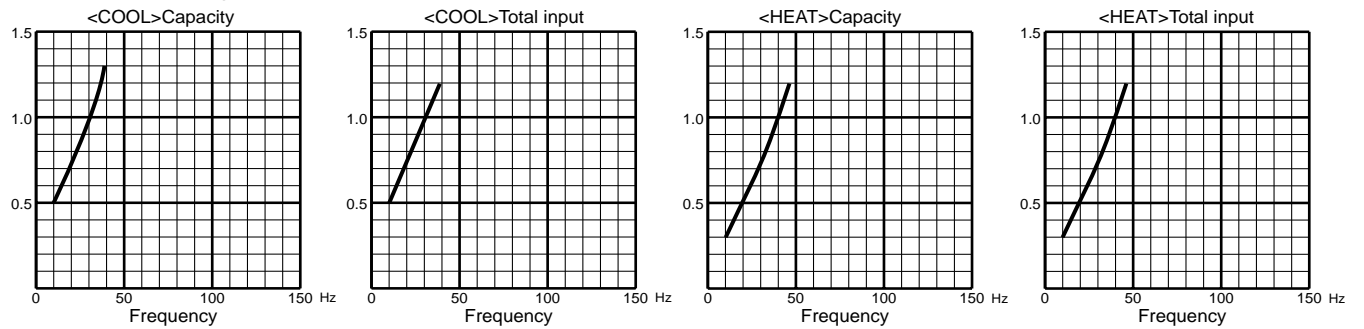

(OUTDOOR UNIT: MXZ-4A80VA)

4. 42-class unit in single operation

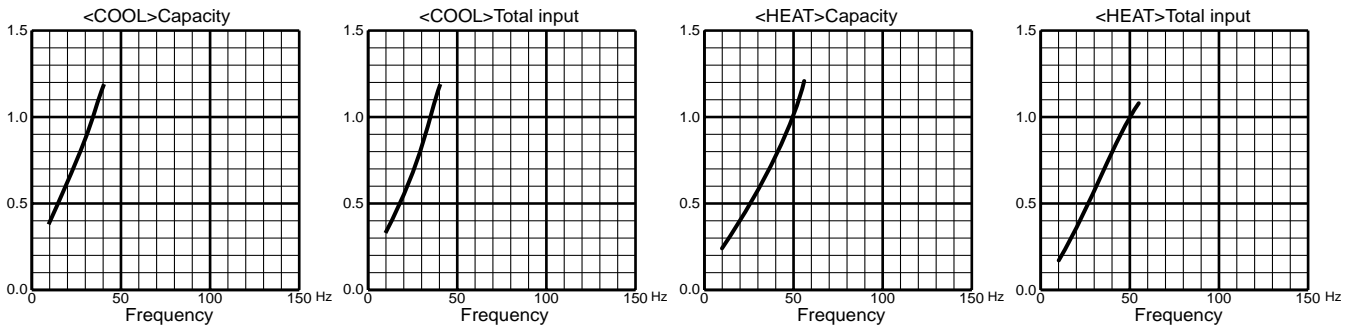

5. 50-class unit in single operation

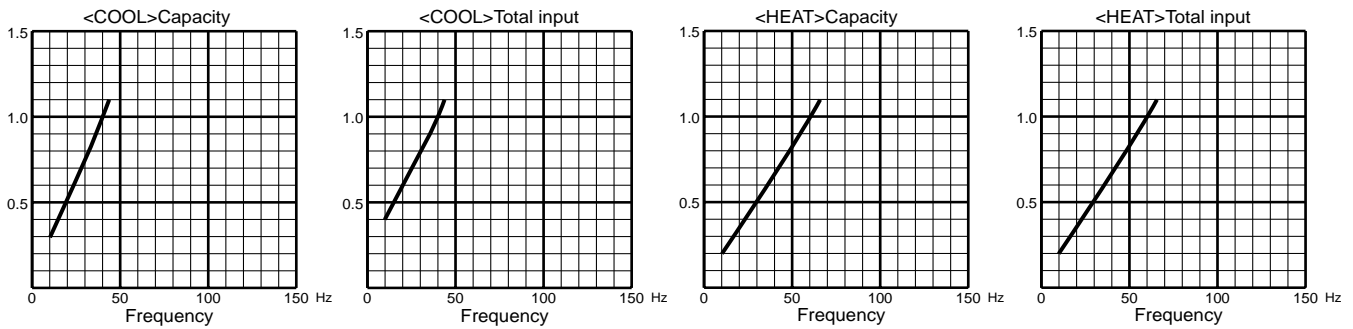

6. 60-class unit in single operation

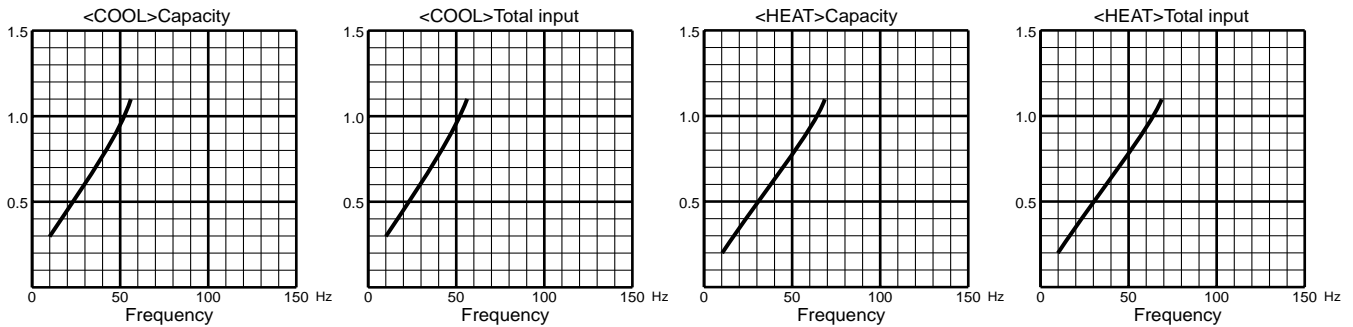

7. 71-class unit in single operation

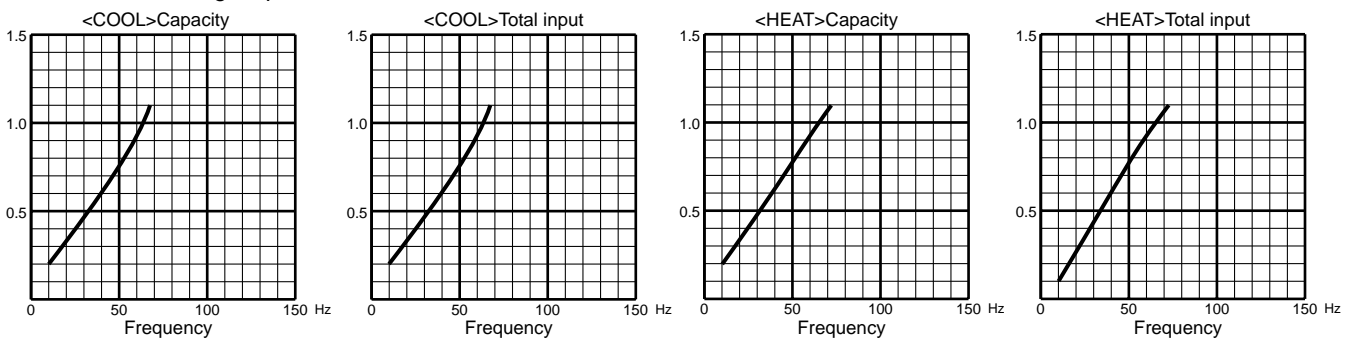

(OUTDOOR UNIT: MXZ-5A100VA)

1. 22-class unit in single operation

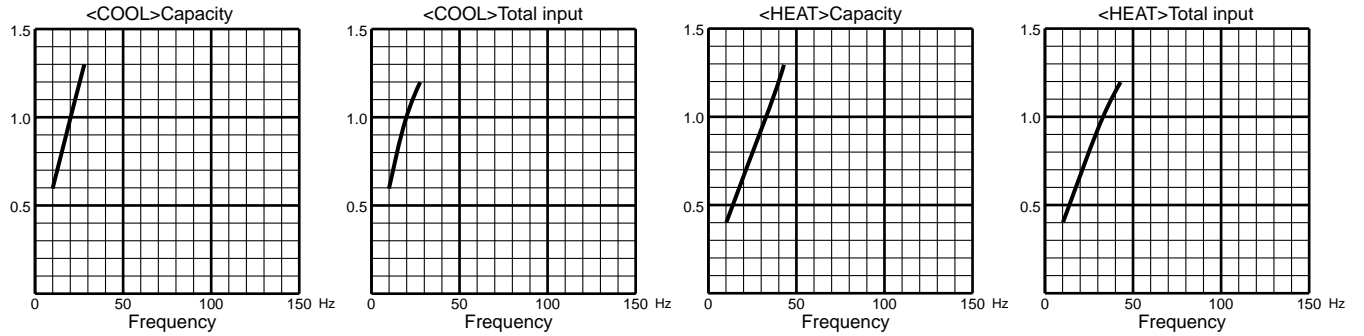

2. 25-class unit in single operation

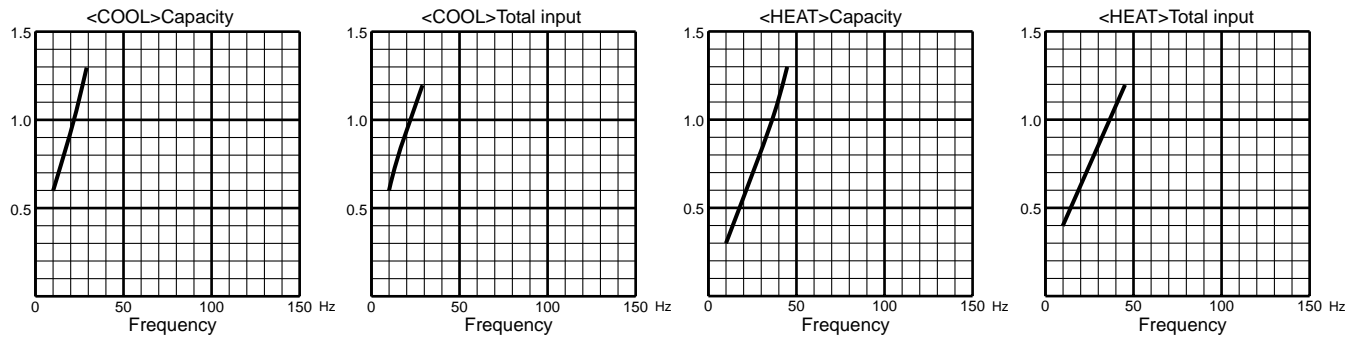

3. 35-class unit in single operation

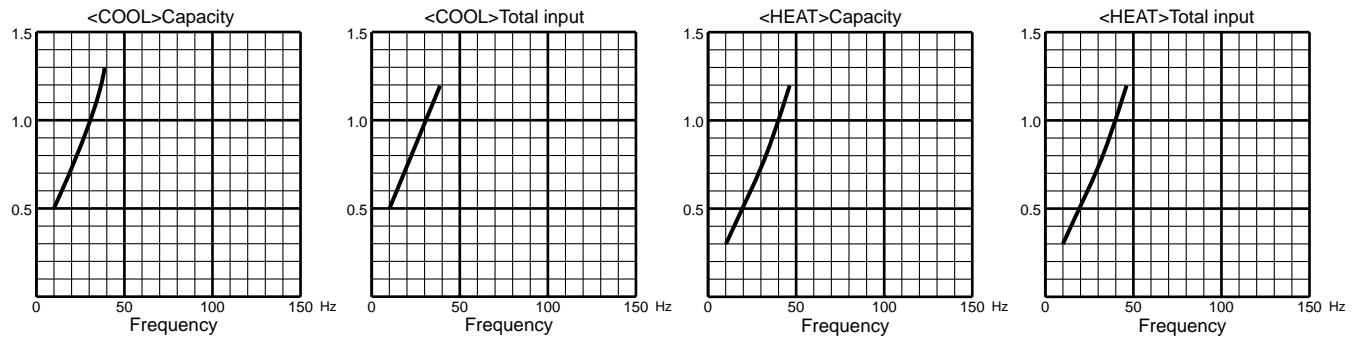

4. 42-class unit in single operation

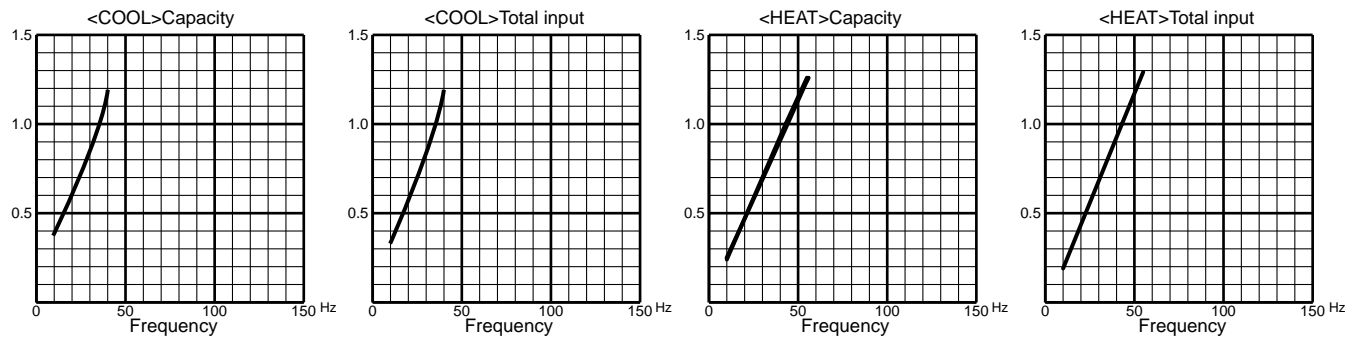

5. 50-class unit in single operation

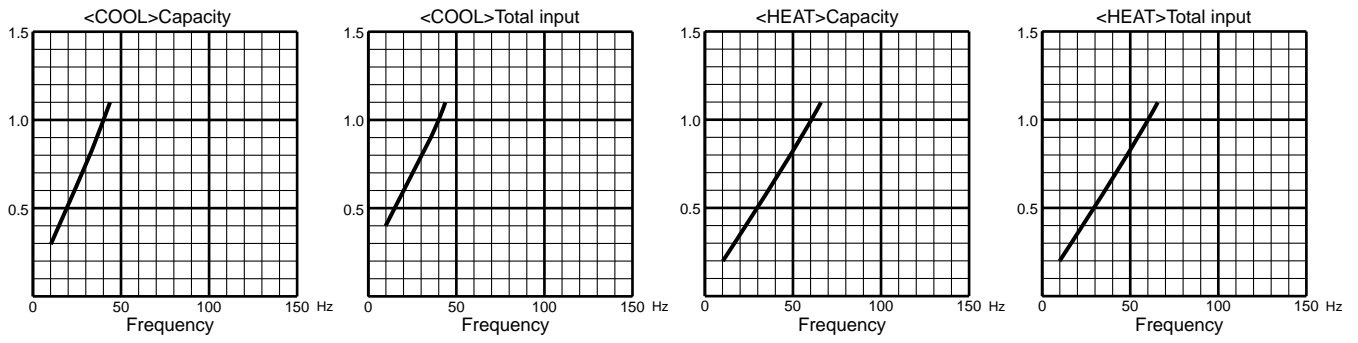

6. 60-class unit in single operation

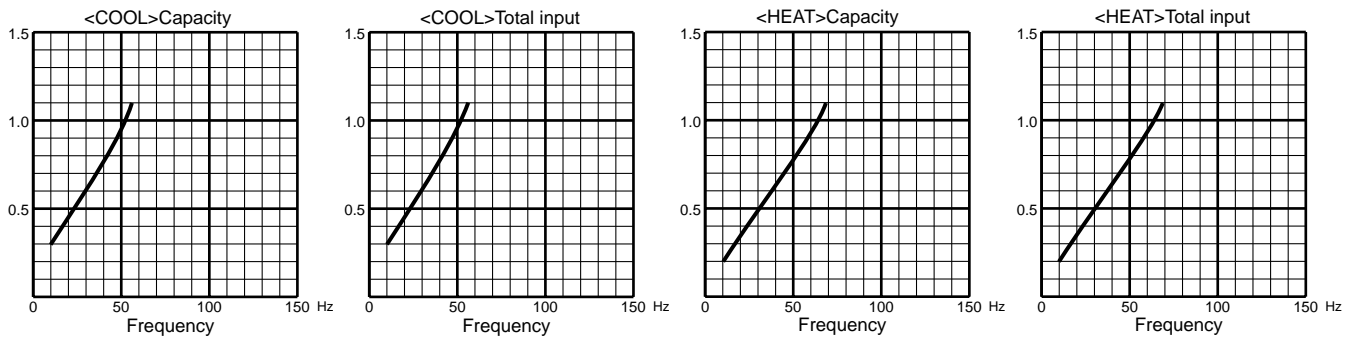

7. 71-class unit in single operation

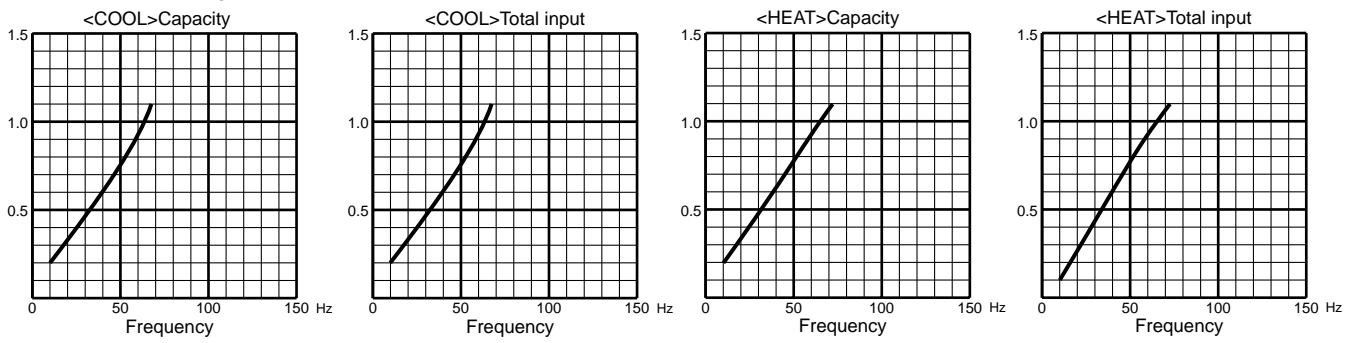

10-3. TEST RUN OPERATION (How to operate fixed-frequency operation)

1. Press EMERGENCY OPERATION switch to COOL or HEAT mode (COOL : Press once, HEAT : Press twice).
2. Test run operation starts and continues to operate for 30 minutes.
3. Compressor operates at rated frequency.
4. Indoor fan operates at High speed.
5. After 30 minutes, test run operation finishes and EMERGENCY OPERATION starts (Operation frequency of compressor varies).
6. To cancel test run operation (EMERGENCY OPERATION), press EMERGENCY OPERATION switch or any button on remote controller.

10-4. OUTDOOR LOW PRESSURE AND OUTDOOR UNIT CURRENT (single operation)

NOTE: The unit of pressure has been changed to MPa on the international system of units (SI unit system).

The conversion factor is : **1 (MPa[Gauge]) = 10.2(kgf/cm² [Gauge])**

(1) COOL operation

- ① Both indoor and outdoor unit are under the same temperature/humidity condition.
- ② Operation : TEST RUN OPERATION (Refer to 10-3.)

Dry-bulb temperature (°C)	Relative humidity (%)
20	50
25	60
30	70

MXZ-2A30VA MXZ-2A40VA - E2

22-class unit

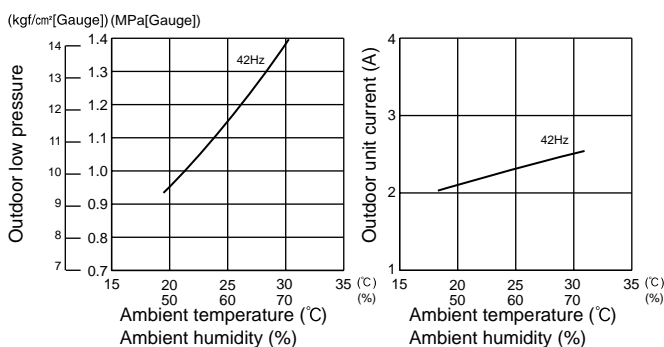

25-class unit

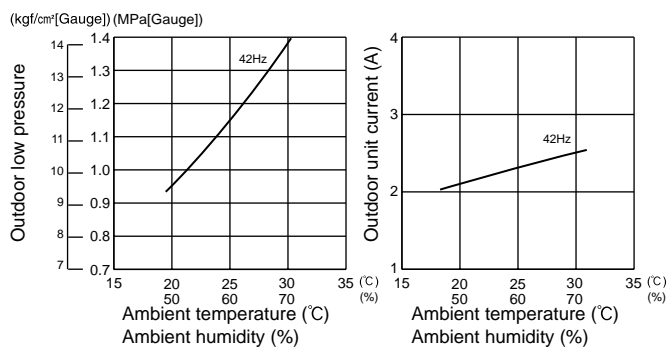

MXZ-2A40VA- E2

35-class unit

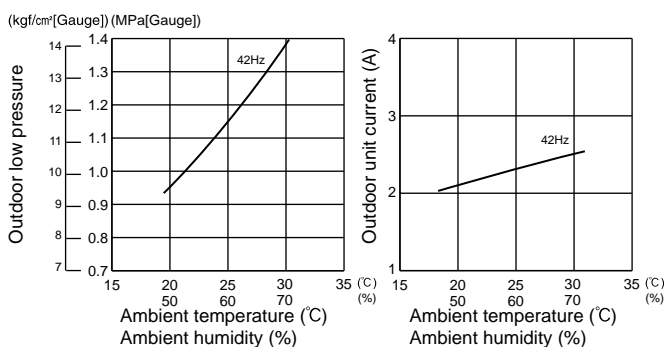

MXZ-3A54VA MXZ-4A71VA
50-class unit

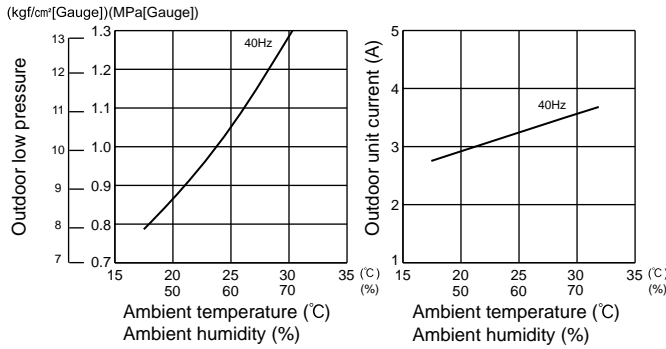

MXZ-4A71VA
60-class unit

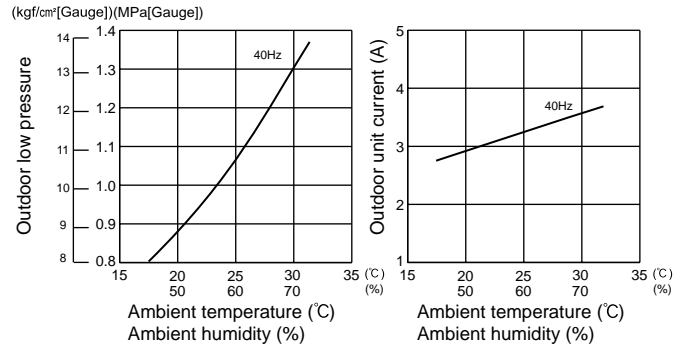

MXZ-4A80VA
22-class unit

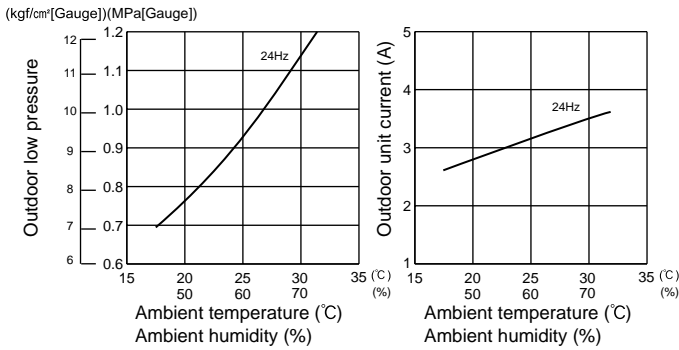

25-class unit

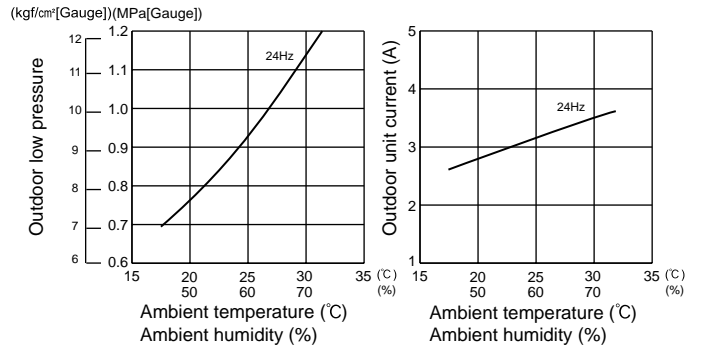

35-class unit

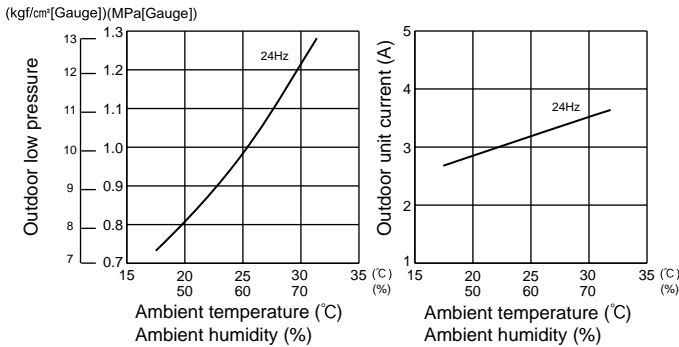

42-class unit

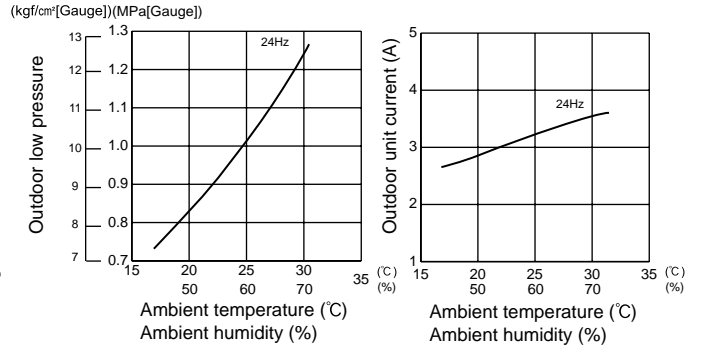

50-class unit

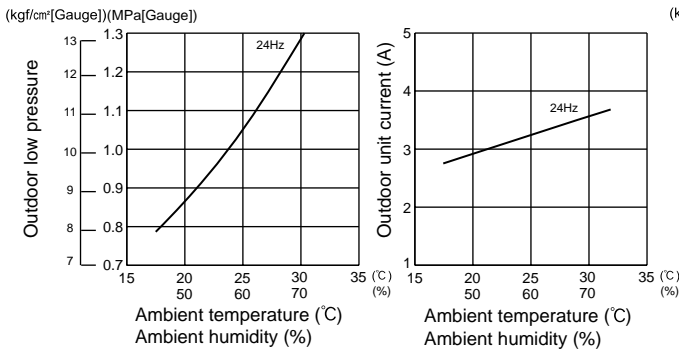

60-class unit

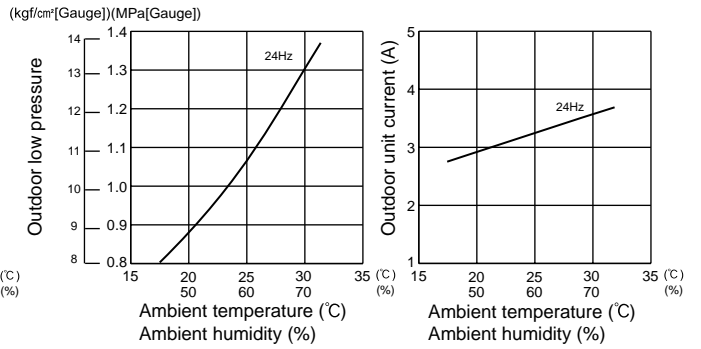

HEAT operation

① Condition :

	Indoor	Outdoor			
Dry bulb temperature (°C)	20.0	2	7	15	20.0
Wet bulb temperature (°C)	14.5	1	6	12	14.5

② Operation : TEST RUN OPERATION (Refer to 10-3.)

MXZ-2A30VA MXZ-2A40VA- E2

22-class unit

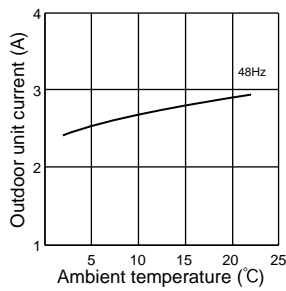

25-class unit

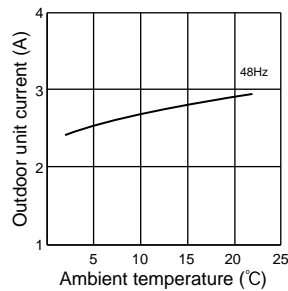

MXZ-2A40VA- E2

35-class unit

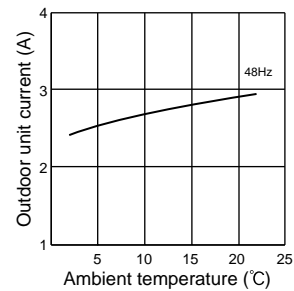

MXZ-2A40VA- E1 MXZ-2A52VA

22-class unit

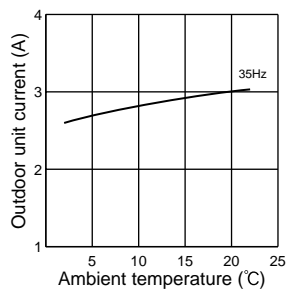

25-class unit

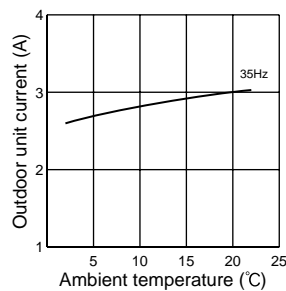

35-class unit

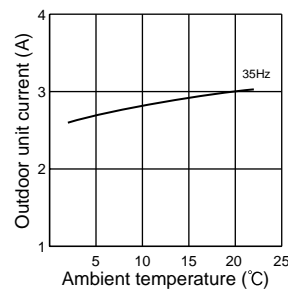

MXZ-3A54VA MXZ-4A71VA

22-class unit

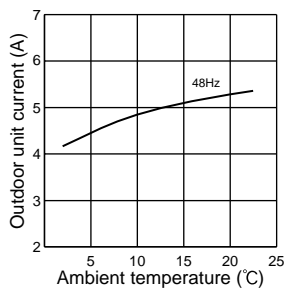

25-class unit

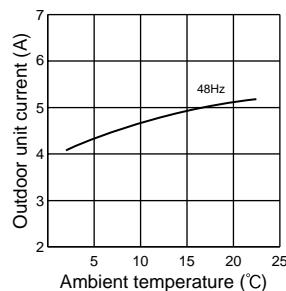

35-class unit

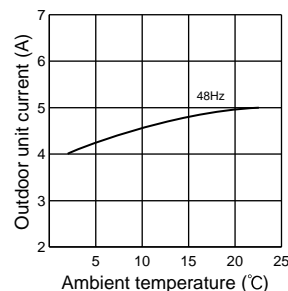

42-class unit

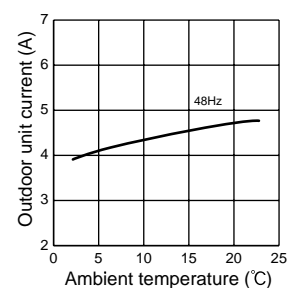

MXZ-3A54VA MXZ-4A71VA

50-class unit

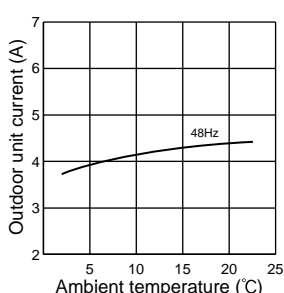

MXZ-4A71VA

60-class unit

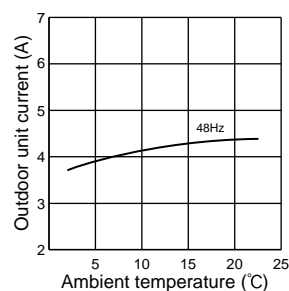

**MXZ-2A30VA MXZ-2A40VA MXZ-2A52VA MXZ-3A54VA MXZ-4A71VA MXZ-4A80VA
MXZ-5A100VA**

Relation between main sensor and actuator

Sensor	Purpose	Actuator			
		Compressor	LEV	Outdoor fan motor	Reversing valve
Discharge temperature thermistor	Protection	○	○		
Indoor coil thermistor	Defrosting Protection	○	○	○	
Defrost thermistor	Defrosting	○	○	○	○
Gas pipe temperature thermistor MXZ-3A54VA- E1 , E2 , E3 MXZ-4A71VA- E1 , E2 , E3 MXZ-4A80VA- E1	Control		○		
Fin temperature thermistor	Protection	○		○	
Ambient temperature thermistor	Control	○	○	○	
Outdoor heat exchanger temperature	Protection	○	○	○	
Capacity code	Control	○	○		

MXZ-2A30VA MXZ-2A40VA MXZ-2A52VA MXZ-3A54VA MXZ-4A71VA MXZ-4A80VA MXZ-5A100VA

12-1. LOCKING THE OPERATION MODE OF THE CONDITIONER (COOL, DRY, HEAT)

Description of the function:

With this function, you can lock the operation mode of the outdoor unit. Once the operation mode is locked to either COOL/DRY mode or HEAT mode, the air conditioner operates in that mode only.

Initial setting is required to activate this function. Please explain about this function to your customers and ask them whether they want to use it.

[How to lock the operation mode]

- Turn OFF the power supply for the air conditioner before making the setting.
- Set SW1 on the display P.C. board or the outdoor electronic control P.C. board as shown in the right figure.
- Turn ON the power supply for the air conditioner.

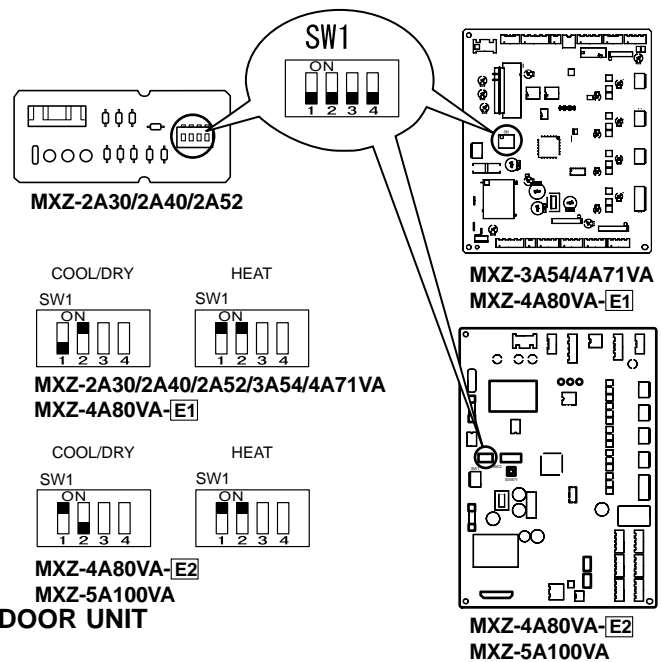

12-2. LOWERING THE OPERATING NOISE OF THE OUTDOOR UNIT

Description of the function:

With this function, you can lower the operating noise of the outdoor unit when the operation load is small, for example, during nighttime in COOL mode. However, please note that the cooling and heating capacity can also be lowered if this function is activated.

Initial setting is required to activate this function. Please explain about this function to your customers and ask them whether they want to use it.

[How to lower the operating noise]

- Turn OFF the power supply for the air conditioner before making the setting.
- Set the "3" of SW1 on the display P.C. board or the outdoor electronic control P.C. board to ON to enable this function.
- Turn ON the power supply for the air conditioner.

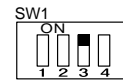

12-3. PRE-HEAT CONTROL <MXZ-2A, MXZ-3A54VA-E4, E5, E6, E7, MXZ-4A71VA-E4, E5, E6, E7, MXZ-4A80VA-E2, MXZ-5A100VA>

If moisture gets into the refrigerant cycle, or when refrigerant is liquefied and collected in the compressor, it may interfere the start-up of the compressor.

To improve start-up condition, the compressor is energized even while it is not operating.

This is to generate heat at the winding.

The compressor uses about 50 W when pre-heat control is turned ON.

Pre-heat control is ON at initial setting.

[How to deactivate pre-heat control]

- Turn OFF the power supply for the air conditioner before making the setting.
- Set the "4" of SW2 on the outdoor electronic control P.C. board to ON to deactivate pre-heat control function (MXZ-4A80VA-E2, MXZ-5A100VA). Set the "4" of SW1 on the outdoor electronic control P.C. board to ON to deactivate pre-heat control function (MXZ-3A54VA-E4, E5, E6, E7, MXZ-4A71VA-E4, E5, E6, E7). Cut the JK wire of the inverter P.C. board to deactivate pre-heat control function (MXZ-2A).

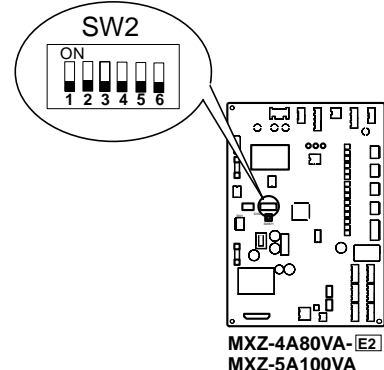
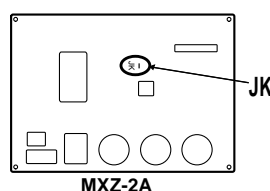
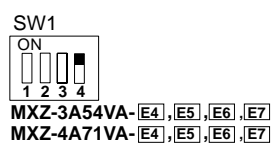
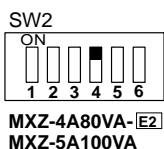

- Turn ON the power supply for the air conditioner.

NOTE: Pre-heat control will be turned OFF when the breaker is turned OFF.

12-4. AUTO LINE CORRECTING

Outdoor unit has an auto line correcting function which automatically detects and corrects improper wiring or piping.

<MXZ-2A>

Improper wiring or piping can be automatically detected when one indoor unit is operated in COOL mode for 30 minutes. When improper wiring or piping is detected, wiring lines are corrected (A to B/ B to A) with the software.

NOTE:

This function may not work due to the condition or environment of the unit, such as the following:

- gas leak, closed stop valve
- unit failure such as defective LEV
- indoor/outdoor temperature

<Correct line>

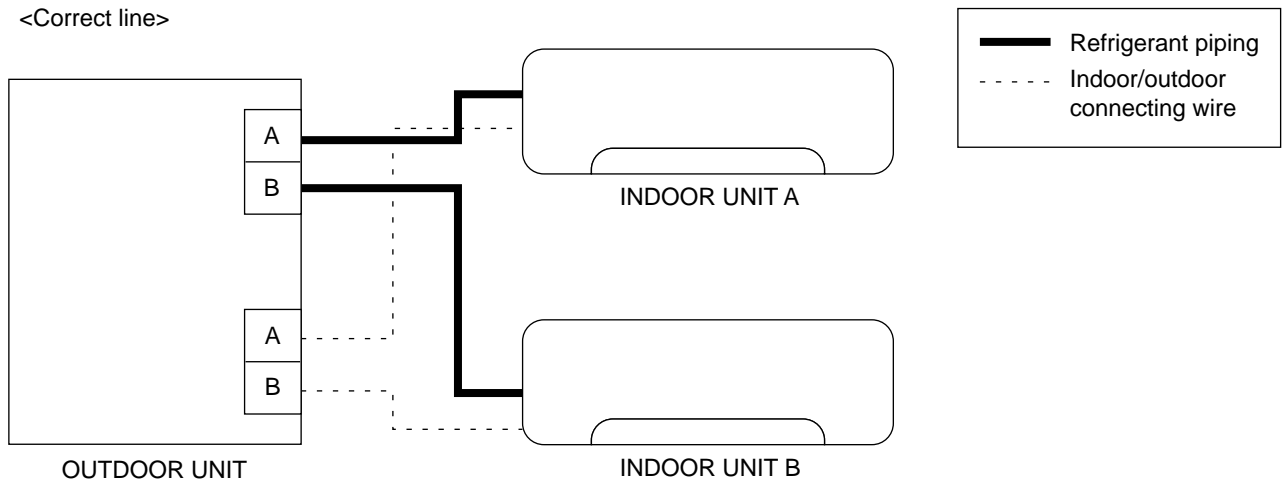

<Incorrect wiring>

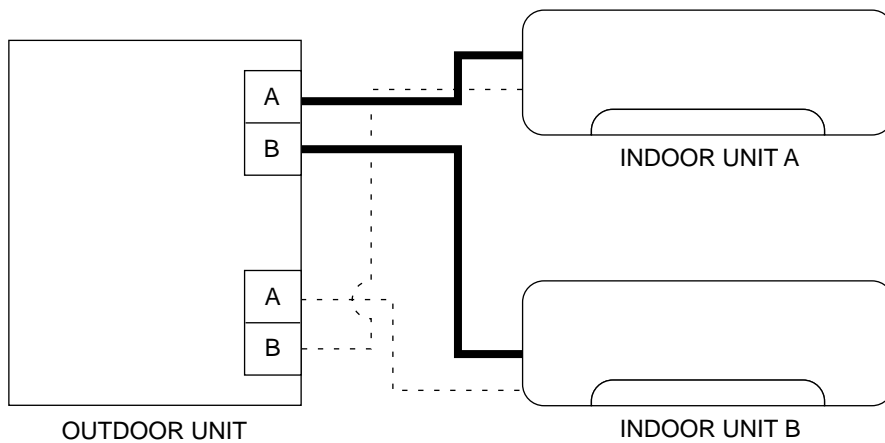

<Incorrect piping>

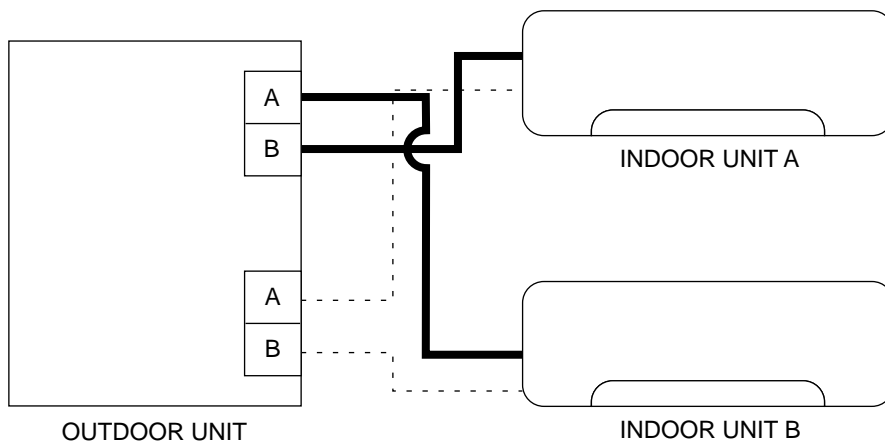

The record of auto line correcting can be confirmed in the following way:

- ① Turn OFF the power supply.
- ② Turn ON the "4" of SW1 on the display P.C. board.
- ③ Turn ON the power supply.
- ④ Confirm the correction by the blinking of LED.

Number of blinks		Wiring line
LED1 (Red)	LED2 (Yellow)	
Once	Once	Not corrected
3 times	3 times	Corrected



- ⑤ Turn OFF the power supply after the confirmation, and turn OFF the "4" of SW1 on the display P.C. board.
- ⑥ Turn ON the power supply.

NOTE: This function does not work when the jumper wire JGO on the inverter P.C. board is cut.

<MXZ-4A80VA- [E2], MXZ-5A100VA>

Improper wiring or piping can be automatically detected by pressing the piping/wiring correction switch (SW871). When improper wiring or piping is detected, wiring lines are corrected. This will be completed in about 10 to 15 min.

[How to activate this function]

1. Check that outside temperature is above 0°C .
(This function does not work when outside temperature is not above 0°C.)
2. Check that the stop valves of the liquid pipe and gas pipe are open.
3. Check that the wiring between indoor and outdoor unit is correct.
(If the wiring is not correct, this function does not work.)
4. Turn ON the power supply and wait at least 1 minute.
5. Press the piping/wiring correction switch (SW871) on the electronic control P.C. board.
Do not touch energized parts.

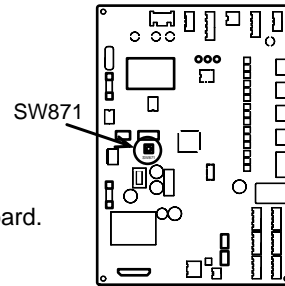

LED indication during detection:

LED1(Red)	LED2(Yellow)	LED3(Green)
Lighting	Lighting	Blinking

LED indication after detection:

LED1(Red)	LED2(Yellow)	LED3(Green)	Indication
Lighting	Goes out	Lighting	Completed (Detected successfully)
Blinking	Blinking	Blinking	Cannot be corrected
Other indications			Refer to "SAFETY PRECAUTIONS WHEN LED FLASHES" located behind the service panel.

*Make sure that the valves are open and the pipes are not collapsed or clogged.

6. Press the switch to cancel.

LED indication after cancel:

LED1(Red)	LED2(Yellow)	LED3(Green)
Lighting	Lighting	Goes Out

NOTE: Indoor unit cannot be operated while this function is activated.

When this function is activated while indoor unit is operating, the operation will be stopped.

Operate indoor unit after the auto line correcting is finished.

Pressing the switch during detection cancels this function.

The record of auto line correcting can be confirmed in the following way:

Press the switch for more than 5 sec.

LED will show the record of auto correcting for about 30 sec. as shown in the table below:

Number of blinks			Wiring line
LED1(Red)	LED2(Yellow)	LED3(Green)	
Once	Once	Lighting	Not corrected
3 times	3 times	Lighting	Corrected

NOTE: Activate this function to confirm the correct wiring after replacing the electronic control P.C. board.

(Previous records are deleted when the electronic control P.C. board is replaced.)

The record cannot be shown if auto line correcting is not canceled (Refer to "How to activate this function").

12-5. INCREASING MAXIMUM COMPRESSOR OPERATIONAL FREQUENCY AND FAN SPEED OF THE OUTDOOR UNIT

<MXZ-4A80VA- [E2], MXZ-5A100VA>

Compressor operational frequency and fan speed can be increased.

Capacity of the unit can be improved with this function.

NOTE:

Compressor operational frequency may not be increased under primary current restriction or high pressure protection.

Compressor operational frequency will not be increased when 1 or 2 indoor units are operating.

This function doesn't work when the function which lowers the operating noise of the outdoor unit is activated.

Noise level of the outdoor unit will increase (You may need to explain this to your customers.)

[How to increase maximum compressor operational frequency and fan speed]

- ① Turn OFF the power supply for the air conditioner before making the setting.
- ② Set the "3" of SW2 on the outdoor electronic control P.C. board to ON to enable this function.
- ③ Turn ON the power supply for the air conditioner.



12-6. CHANGING DEFROST FINISH TEMPERATURE AND HEAT OPERATION TIME

<MXZ-4A80VA- [E2], MXZ-5A100VA>

If defrosting operation starts more than necessary, the defrost finish temperature and heat operation time can be changed.

The number of defrosting operation and defrosting time can be reduced with this function.

	Initial setting	Changed
Defrost finish temperature (°C)	10	5
Heat operation time (min.)	31	40

[How to change defrost finish temperature and heat operation time]

- ① Turn OFF the power supply for the air conditioner before making the setting.
- ② Set the "1" of SW2 on the outdoor electronic control P.C. board to ON to enable this function.
- ③ Turn ON the power supply for the air conditioner.

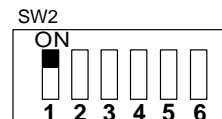

12-7. CHANGING THE AMPERE LIMIT

<MXZ-4A80VA- [E2], MXZ-5A100VA>

With this function, you can change the current that flows in the outdoor unit.

NOTE:

Use this function only when the amount of current exceeds the allowed value.

[How to change the ampere limit]

- ① Be sure to turn OFF the power supply for the air conditioner before making the setting.
- ② Make the setting referring to the table on the right.
- ③ Turn ON the power supply for the air conditioner.

SW 2	MXZ-4A80VA -[E2] MXZ-5A100VA
	10.5A
	15.5A
	Initial setting Full

MXZ-2A30VA MXZ-2A40VA MXZ-2A52VA MXZ-3A54VA MXZ-4A71VA MXZ-4A80VA MXZ-5A100VA

13-1. CAUTIONS ON TROUBLESHOOTING

1. Before troubleshooting, check the following:

- 1) Check the power supply voltage.
- 2) Check the indoor/outdoor connecting wire for miswiring.

2. Take care of the following during servicing

- 1) Before servicing the air conditioner, be sure to turn OFF the unit first with the remote controller, and after confirming the horizontal vane is closed, turn OFF the breaker and/or disconnect the power plug.
- 2) Be sure to turn OFF the power supply before removing the front panel, the cabinet, the top panel, and the electronic control P.C. board.
- 3) When removing the electrical parts, be careful of the residual voltage of smoothing capacitor.
- 4) When removing the electronic control P.C. board, hold the edge of the board with care NOT to apply stress on the components.
- 5) When connecting or disconnecting the connectors, hold the housing of the connector. DO NOT pull the lead wires.

<Incorrect>

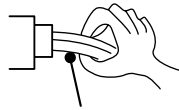

Lead wiring

<Correct>

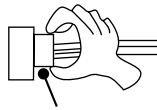

Housing point

3. Troubleshooting procedure

- 1) Check if the OPERATION INDICATOR lamp on the indoor unit is flashing on and off to indicate an abnormality. To make sure, check how many times the OPERATION INDICATOR lamp is flashing on and off before starting service work.
- 2) When the electronic control P.C. board seems to be defective, check the copper foil pattern for disconnection and the components for bursting and discoloration.
- 3) When troubleshooting, refer to 13-2, 13-3 and 13-4.

13-2. FAILURE MODE RECALL FUNCTION

This air conditioner can memorize the abnormal condition which has occurred once.

Even though LED indication listed on the troubleshooting check table (13-4) disappears, the memorized failure details can be recalled.

1. Flow chart of failure mode recall function for the indoor/outdoor unit

Refer to the service manual of indoor unit.

2. Flow chart of the detailed outdoor unit failure mode recall function

Operational procedure

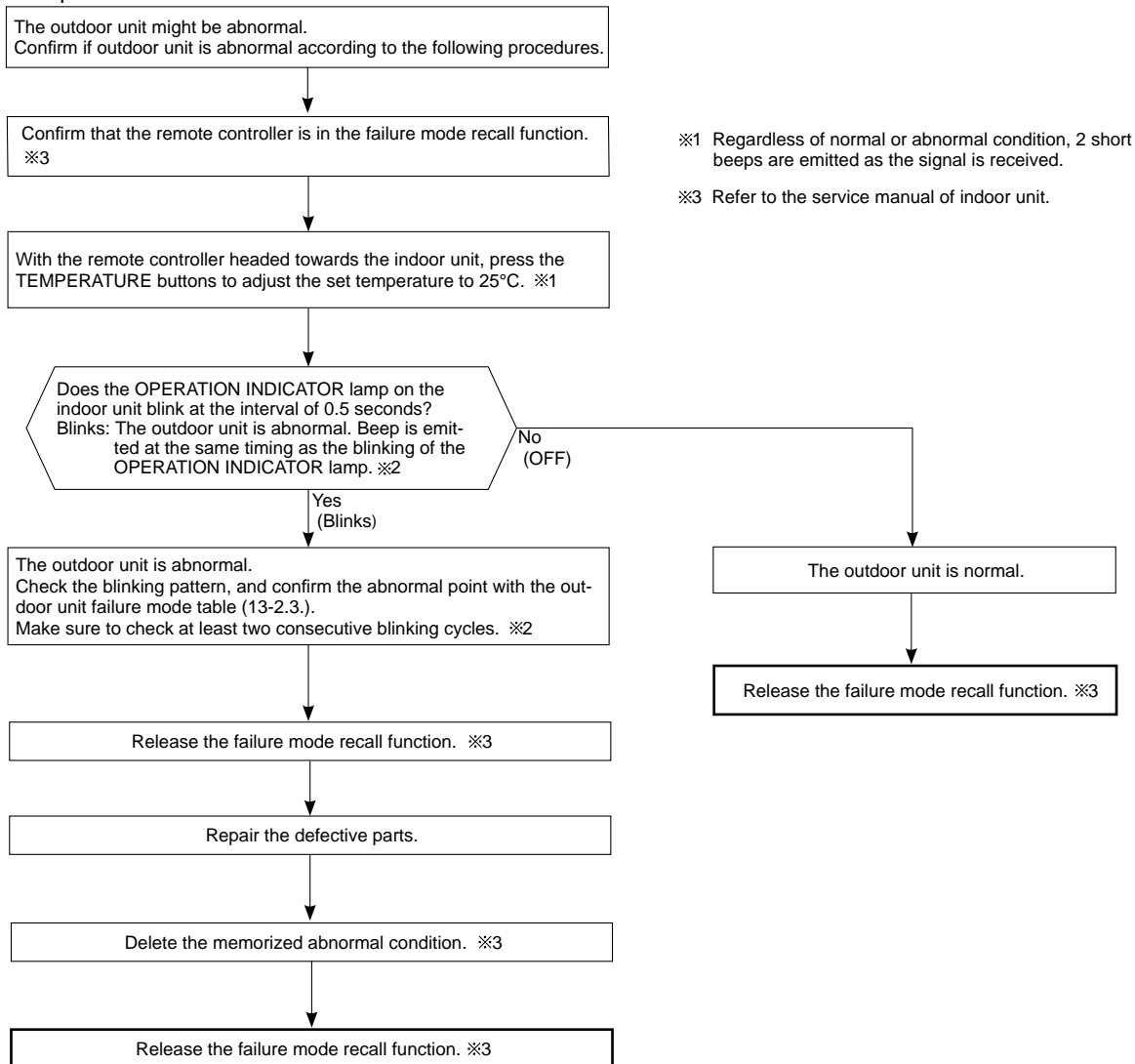

NOTE: 1. Make sure to release the failure mode recall function once it is set up, otherwise the unit cannot operate properly.
2. If the abnormal condition is not deleted from the memory, the last abnormal condition is kept memorized.

※2. Blinking pattern when outdoor unit is abnormal:

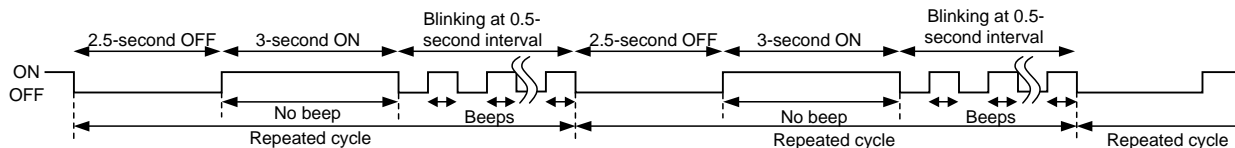

3. Outdoor unit failure mode table

MXZ-2A

Upper or left lamp of OPERATION INDICATOR lamp (Indoor unit)	Abnormal point (Failure mode / protection)	LED indication (Outdoor P.C. board)		Condition	Remedy	Indoor/outdoor unit failure mode recall function
		LED 1	LED 2			
OFF	None (Normal)	Lighting	Lighting	—	—	—
2-time flash	Outdoor power system	Lighting	Lighting	Overcurrent protection cut-out operates 3 consecutive times within 1 minute after the compressor gets started.	<ul style="list-style-type: none"> • Check the connection of the compressor connecting wire. • Refer to 13-6.⑥ "How to check inverter/compressor". • Check the stop valve. 	○
3-time flash	Discharge temperature thermistor	Lighting	Once	Thermistor shorts or opens during compressor running.	<ul style="list-style-type: none"> • Refer to 13-6.⑥ "Check of outdoor thermistors". 	○
	Defrost thermistor	Lighting	Once			
	Ambient temperature thermistor	Lighting	Twice			
	Fin temperature thermistor	Lighting	3 times			
	P.C. board temperature thermistor	Lighting	4 times			
	Outdoor heat exchanger temperature thermistor	Lighting	9 times			
4-time flash	Overcurrent	Once	Goes out	23 A (MXZ-2A30VA- ^① , MXZ-2A40VA, MXZ-2A52VA) / 14 A (MXZ-2A30VA- ^②) current flows into intelligent power module.	<ul style="list-style-type: none"> • Reconnect compressor connector. • Refer to 13-6.⑥ "How to check inverter/compressor". • Check the stop valve. 	—
	Compressor	Twice	Goes out	The possibility of intercepting the overcurrent by the compressor lock is high.	<ul style="list-style-type: none"> • Check the connection of the compressor connecting wire. • Refer to 13-6.⑥ "How to check inverter/compressor". 	—
		9 times	Goes out	The compressor doesn't synchronize with the operating power.		
5-time flash	Discharge temperature	Lighting	Lighting	Discharge temperature exceeds 116°C during operation. Compressor can restart if discharge temperature thermistor reads 100°C or less 3 minutes later.	<ul style="list-style-type: none"> • Check refrigerant circuit and refrigerant amount. • Refer to 13-6.⑦ "Check of LEV". 	—
6-time flash	High pressure	Lighting	Lighting	The outdoor heat exchanger temperature exceeds 70°C during cooling or the indoor gas pipe temperature exceeds 70°C during heating.	<ul style="list-style-type: none"> • Check refrigerant circuit and refrigerant amount. • Check the stop valve. 	—
7-time flash	Fin temperature	3 times	Goes out	The fin temperature exceeds 90°C during operation.	<ul style="list-style-type: none"> • Check around outdoor unit. • Check outdoor unit air passage. • Refer to 13-6.⑧ "Check of outdoor fan motor". 	—
	P.C. board temperature	4 times	Goes out	The P.C. board temperature exceeds 78°C during operation.		
8-time flash	Outdoor fan motor	Lighting	Lighting	Failure occurs continuously three times within 30 seconds after the fan gets started.	<ul style="list-style-type: none"> • Refer to 13-6.⑧ "Check of outdoor fan motor". 	—
9-time flash	Nonvolatile memory data	Lighting	5 times	Nonvolatile memory data cannot be read properly.	<ul style="list-style-type: none"> • Replace the outdoor electronic control P.C. board. 	○
10-time flash	Discharge temperature	Lighting	Lighting	The frequency of the compressor is kept 68 Hz (MXZ-2A30VA, MXZ-2A40VA- ^②) / 80Hz (MXZ-2A40VA- ^① , MXZ-2A52VA) or more and the discharge temperature is kept under 50°C (COOL mode)/40°C (HEAT mode) for more than 40 minutes.	<ul style="list-style-type: none"> • Check refrigerant circuit and refrigerant amount. • Refer to 13-6.⑦ "Check of LEV". 	—

NOTE: Blinking patterns of this mode differ from the ones of Troubleshooting check table (13-4).

Upper or left lamp of OPERATION INDICATOR lamp (Indoor unit)	Abnormal point (Failure mode / protection)	LED indication (Outdoor P.C. board)		Condition	Remedy	Indoor/outdoor unit failure mode recall function
		LED 1	LED 2			
11-time flash	Current sensor	8 times	Goes out	A short or open circuit is detected in the current sensor during compressor operating.	• Replace the power board.	—
	Bus-bar voltage	6 times	Goes out	The bus-bar voltage exceeds 430 V or falls to 50 V or below during compressor operating.	• Replace the power board.	—
14-time flash	Power module	7 times	Goes out	There is a high possibility that the power module is out of order.	• Refer to 13-6.⑥ "How to check inverter/compressor".	—
	Stop valve (Closed valve)	Lighting	12 times	Closed valve is detected by compressor current. (MXZ-2A30VA, MXZ-2A40VA -E2)	• Check the stop valve.	—
15-time flash	LEV and drain pump	Lighting	Lighting	The indoor unit detects an abnormality in the LEV and drain pump.	• Refer to 13-6.⑦ "Check of LEV". • Check the drain pump of the indoor unit.	—

NOTE: Blinking patterns of this mode differ from the ones of Troubleshooting check table (13-4).

MXZ-3A/4A/5A

Upper or left lamp of OPERATION INDICATOR lamp (Indoor unit)	Abnormal point (Failure mode / protection)	LED indication (Outdoor P.C. board)		Condition	Remedy	Indoor/outdoor unit failure mode recall function
		LED 1	LED 2			
OFF	None (Normal)	Lighting	Lighting	—	—	—
2-time flash	Outdoor power system	Lighting	Lighting	Overcurrent protection cut-out operates 3 consecutive times within 1 minute after the compressor gets started, or converter protection cut-out or bus-bar voltage protection cut-out operates 3 consecutive times within 3 minutes after start-up.	<ul style="list-style-type: none"> • Check the connection of the compressor connecting wire. • Refer to 13-6.⑤ "How to check inverter/compressor". • Check the stop valve. 	○
3-time flash	Discharge temperature thermistor	Lighting	Once	Thermistor shorts or opens during compressor running.	<ul style="list-style-type: none"> • Refer to 13-6.⑥ "Check of outdoor thermistors". 	○
	Defrost thermistor	Lighting	Once			
	Ambient temperature thermistor	Lighting	Twice			
	Fin temperature thermistor	Lighting	3 times			
	P.C. board temperature thermistor	Lighting	4 times			
	Outdoor heat exchanger temperature thermistor	Lighting	9 times	A short or open circuit is detected in the thermistor during cooling. (A,B,C : MXZ-3A54VA -E1,E2,E3 MXZ-4A71VA -E1,E2,E3 MXZ-4A80VA -E1) (D : MXZ-4A71VA -E1,E2,E3 MXZ-4A80VA -E1)	<ul style="list-style-type: none"> • Replace the outdoor electronic control P.C. board. • Refer to 13-6.⑥ "Check of outdoor thermistors". 	
	Gas pipe temperature thermistor A	Lighting	10 times			
	Gas pipe temperature thermistor B	Lighting	11 times			
	Gas pipe temperature thermistor C	Lighting	12 times			
Gas pipe temperature thermistor D	Lighting	13 times				
4-time flash	Overcurrent	Once	Goes out	28A current flows into intelligent power module.	<ul style="list-style-type: none"> • Reconnect compressor connector. • Refer to 13-6.⑤ "How to check inverter/compressor". • Check the stop valve. 	—
5-time flash	Discharge temperature	Lighting	Lighting	Discharge temperature exceeds 116°C during operation. Compressor can restart if discharge temperature thermistor reads 100°C or less 3 minutes later.	<ul style="list-style-type: none"> • Check refrigerant circuit and refrigerant amount. • Refer to 13-6.⑩ "Check of LEV". 	—
6-time flash	High pressure	Lighting	Lighting	High-pressure is detected with the high-pressure switch (HPS) during operation. (MXZ-4A80VA , MXZ-5A100VA)	<ul style="list-style-type: none"> • Check refrigerant circuit and refrigerant amount. • Check the stop valve. 	—
				The outdoor heat exchanger temperature exceeds 70°C during cooling or the indoor gas pipe temperature exceeds 70°C during heating.		
7-time flash	Fin temperature	3 times	Goes out	The fin temperature exceeds 89°C during operation.	<ul style="list-style-type: none"> • Check around outdoor unit. • Check outdoor unit air passage. • Refer to 13-6.⑨ "Check of outdoor fan motor". 	—
	P.C. board temperature	4 times	Goes out	The P.C. board temperature exceeds 73°C (MXZ-3A54VA , MXZ-4A71VA)/ 87°C (MXZ-4A80VA , MXZ-5A100VA) during operation.		
8-time flash	Outdoor fan motor	Lighting	Lighting	Failure occurs continuously three times within 30 seconds after the fan gets started.	<ul style="list-style-type: none"> • Refer to 13-6.⑨ "Check of outdoor fan motor". 	—
9-time flash	Nonvolatile memory data	Lighting	5 times	Nonvolatile memory data cannot be read properly.	<ul style="list-style-type: none"> • Replace the outdoor electronic control P.C. board. 	○
10-time flash	Discharge temperature	Lighting	Lighting	The frequency of the compressor is kept 80Hz or more and the discharge temperature is kept under 50°C (COOL mode)/40°C (HEAT mode) for more than 40 minutes.	<ul style="list-style-type: none"> • Check refrigerant circuit and refrigerant amount. • Refer to 13-6.⑩ "Check of LEV". 	—

NOTE: Blinking patterns of this mode differ from the ones of Troubleshooting check table (13-4).

Upper or left lamp of OPERATION INDICATOR lamp (Indoor unit)	Abnormal point (Failure mode / protection)	LED indication (Outdoor P.C. board)		Condition	Remedy	Indoor/outdoor unit failure mode recall function
		LED 1	LED 2			
11-time flash	Communication error between P.C. boards	Lighting	6 times	Communication error occurs between the electronic control P.C. board and power board for more than 10 seconds.	<ul style="list-style-type: none"> Check the connecting wire between outdoor electronic control P.C. board and power board. 	—
				The communication between boards protection stop is continuously performed twice.		○
	Current sensor	Lighting	7 times	A short or open circuit is detected in the current sensor during compressor operating.	<ul style="list-style-type: none"> Replace the power board. 	—
				Current sensor protection stop is continuously performed twice.		○
	Zero cross detecting circuit	5 times	Goes out	Zero cross signal cannot be detected while the compressor is operating.	<ul style="list-style-type: none"> Check the connecting wire among electronic control P.C. board, noise filter P.C. board and power board. 	—
				The protection stop of the zero cross detecting circuit is continuously performed 10 times.		○
Converter	5 times	Goes out	A failure is detected in the operation of the converter during operation.	<ul style="list-style-type: none"> Check the voltage of power supply. Replace the power board. 	—	
Bus-bar voltage (1)	5 times	Goes out	The bus-bar voltage exceeds 400 V or falls to 200 V or below during compressor operating.			
Bus-bar voltage (2) * Even if this protection stop is performed continuously three times, it does not mean the abnormality in outdoor power system.	6 times	Goes out	The bus-bar voltage exceeds 400 V (MXZ-3A54VA, MXZ-4A71VA)/ 430 V (MXZ-4A80VA, MXZ-5A100VA) or falls to 50V or below during compressor operating.			
15-time flash	LEV and drain pump	Lighting	Lighting	The indoor unit detects an abnormality in the LEV and drain pump.	<ul style="list-style-type: none"> Refer to 13-6.Ⓓ "Check of LEV". Check the drain pump of the indoor unit. 	—

NOTE: Blinking patterns of this mode differ from the ones of "Troubleshooting check table" (13-4).

13-3. INSTRUCTION OF TROUBLESHOOTING

- Check the indoor unit with referring to the indoor unit service manual, and confirm whether there is any problem in the indoor unit.

Then, check the outdoor unit with referring to this page.

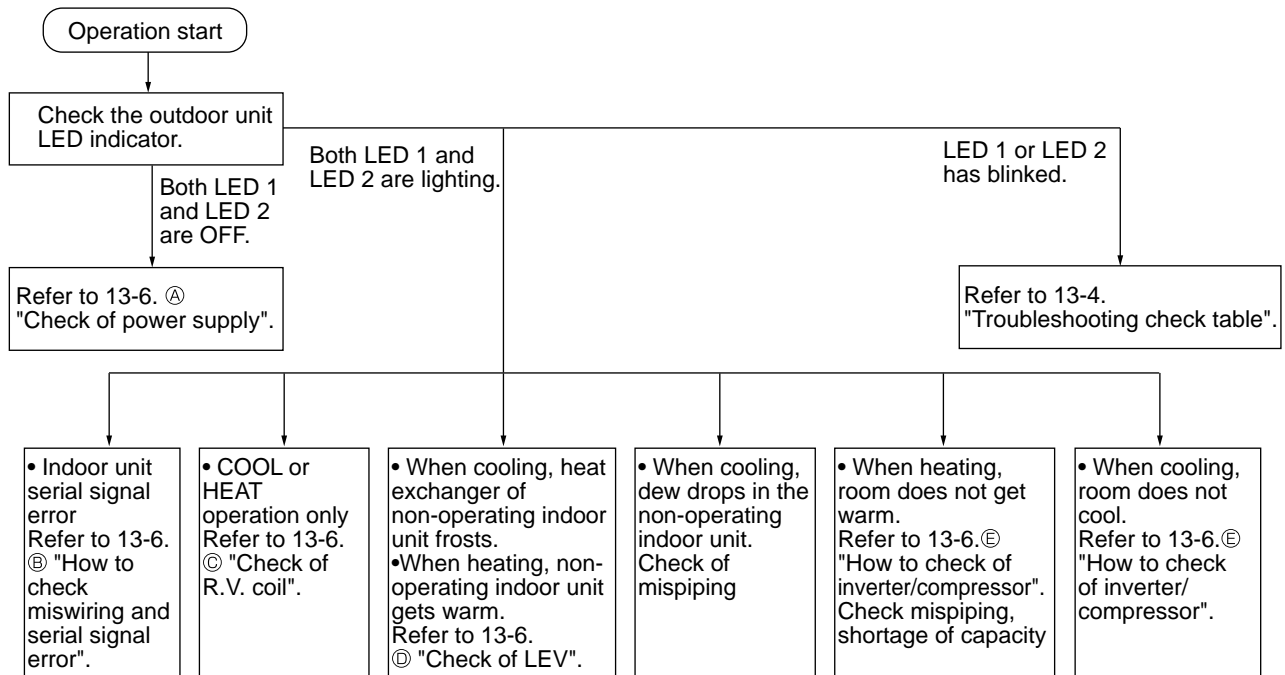

13-4. TROUBLESHOOTING CHECK TABLE

MXZ-2A

No.	Symptom	Indication		Abnormal point / Condition	Condition	Remedy
		LED1(Red)	LED2(Yellow)			
1	Outdoor unit does not operate.	Lighting	Once	LEV and drain pump	The indoor unit detects an abnormality in the LEV and drain pump.	<ul style="list-style-type: none"> Refer to 13-6.Ⓓ "Check of LEV". Check the drain pump of the indoor unit.
2		Lighting	Twice	Outdoor power system	Overcurrent protection cut-out operates 3 consecutive times within 1 minute after the compressor gets started.	<ul style="list-style-type: none"> Check the connection of the compressor connecting wire. Refer to 13-6.Ⓔ "How to check inverter/compressor". Check the stop valve.
3		Lighting	3 times	Discharge temperature thermistor	A short circuit is detected in the thermistor during operation, or when an open circuit is detected in the thermistor after 10 minutes of compressor start-up.	<ul style="list-style-type: none"> Refer to 13-6.Ⓕ "Check of outdoor thermistors".
4		Lighting	4 times	Fin temperature thermistor	A short or open circuit is detected in the thermistor during operation.	<ul style="list-style-type: none"> Refer to 13-6.Ⓕ "Check of outdoor thermistors".
				P.C board temperature thermistor		<ul style="list-style-type: none"> Replace the outdoor electronic control P.C. board.
5		Lighting	5 times	Ambient temperature thermistor	A short or open circuit is detected in the thermistor during operation.	<ul style="list-style-type: none"> Refer to 13-6.Ⓕ "Check of outdoor thermistors".
				Outdoor heat exchanger temperature thermistor	A short circuit is detected in the thermistor during operation, or when an open circuit is detected in the thermistor after 5 minutes (in cooling) and 10 minutes (in heating) of compressor start-up.	
			Defrost thermistor	A short circuit is detected in the thermistor during operation, or when an open circuit is detected in the thermistor after 5 minutes of compressor start-up.		
6	Lighting	7 times	Nonvolatile memory data	The nonvolatile memory data cannot be read properly.	<ul style="list-style-type: none"> Replace the outdoor electronic control P.C. board. 	
7	Lighting	11 times	Stop valve Closed valve	Closed valve is detected by compressor current. (MXZ-2A30VA, MXZ-2A40VA [E2])	<ul style="list-style-type: none"> Check the stop valve. 	
8	'Outdoor unit stops and restarts 3 minutes later' is repeated.	Twice	Goes out	Overcurrent	23 A (MXZ-2A30VA-[E1], MXZ-2A40VA, MXZ-2A52VA)/ 14 A (MXZ-2A30VA-[E2]) current flows into intelligent power module.	<ul style="list-style-type: none"> Reconnect compressor connector. Refer to 13-6.Ⓔ "How to check inverter/compressor". Check the stop valve.
9		3 times	Goes out	Discharge temperature protection	Discharge temperature exceeds 116°C during operation. Compressor can restart if discharge temperature thermistor reads 100°C or less 3 minutes later.	<ul style="list-style-type: none"> Check the amount of gas and refrigerant circuit. Refer to 13-6.Ⓓ "Check of LEV".
10		4 times	Goes out	Fin temperature protection	The fin temperature exceeds 90°C during operation.	<ul style="list-style-type: none"> Check refrigerant circuit and refrigerant amount. Refer to 13-6.Ⓔ "Check of outdoor fan motor".
				P.C. board temperature protection	The P.C. board temperature exceeds 78°C during operation.	
11		5 times	Goes out	High-pressure protection	The outdoor heat exchanger temperature exceeds 70°C during cooling or indoor gas pipe temperature exceeds 70°C during heating.	<ul style="list-style-type: none"> Check the amount of gas and the refrigerant circuit. Check the stop valve.
12		9 times	Goes out	Bus-bar voltage protection	The bus-bar voltage exceeds 430 V or falls to 50 V or below during compressor operating.	<ul style="list-style-type: none"> Replace the power board.
13		13 times	Goes out	Outdoor fan motor	Failure occurs continuously three times within 30 seconds after the fan gets started.	<ul style="list-style-type: none"> Refer to 13-6.Ⓒ "Check of outdoor fan motor".
14		8 times	Goes out	Current sensor protection	A short or open circuit is detected in the current sensor during compressor operating.	<ul style="list-style-type: none"> Replace the power board.
15		10 times	Goes out	Compressor	The compressor doesn't synchronize with the operating power.	<ul style="list-style-type: none"> Reconnect compressor connector. Refer to 13-6.Ⓔ "How to check inverter/compressor". Check the stop valve.
16	Outdoor unit operates.	Once	Lighting	Primary current protection	The input current exceeds 8 A (MXZ-2A30VA)/ 10 A (MXZ-2A40VA, MXZ-2A52VA).	<ul style="list-style-type: none"> These symptoms do not mean any abnormality of the product, but check the following points. Check if indoor filters are clogged. Check if refrigerant is short. Check if indoor/outdoor unit air circulation is short cycled.
				Secondary current protection	The current of the compressor exceeds 17 A.	
17		Twice	Lighting	High-pressure protection	The indoor gas pipe temperature exceeds 45°C during heating.	
				Defrosting in cooling	The indoor gas pipe temperature falls 3°C or below during cooling.	
18	3 times	Lighting	Discharge temperature protection	The discharge temperature exceeds 100°C during operation.	<ul style="list-style-type: none"> Check refrigerant circuit and refrigerant amount. Refer to 13-6.Ⓓ "Check of LEV". Refer to 13-6.Ⓕ "Check of outdoor thermistors". 	
19	4 times	Lighting	Low discharge temperature protection	The frequency of the compressor is kept 80 Hz or more and the discharge temperature is kept under 50°C (COOL mode)/40°C (HEAT mode) for more than 40 minutes.	<ul style="list-style-type: none"> Refer to 13-6.Ⓓ "Check of LEV". Check refrigerant circuit and refrigerant amount. 	



No.	Symptom	Indication		Abnormal point / Condition	Condition	Remedy
		LED1(Red)	LED2(Yellow)			
20	Outdoor unit operates.	5 times	Lighting	Cooling high-pressure protection	The outdoor heat exchanger temperature exceeds 58°C during operation.	This symptom does not mean any abnormality of the product, but check the following points. <ul style="list-style-type: none"> • Check if indoor filters are clogged. • Check if refrigerant is short. • Check if indoor/outdoor unit air circulation is short cycled.
21	Outdoor unit operates normally.	9 times	Lighting	Inverter check mode	The unit is operated with emergency operation switch.	—
22		Lighting	Lighting	Normal	—	—

NOTE 1. The location of LED is illustrated at the right figure. Refer to 13-7.6.
 2. LED is lighted during normal operation.

Display P.C. board(Parts side)

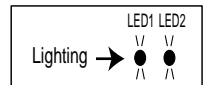

The flashing frequency shows the number of times the LED blinks after every 2.5-second OFF.
 (Example) When the flashing frequency is "2".

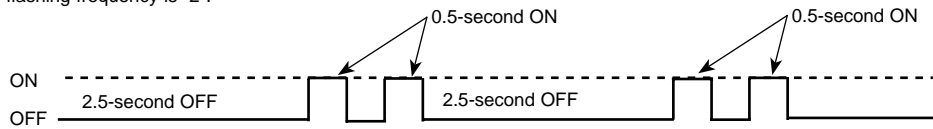

MXZ-3A/4A/5A

No.	Symptom	Indication		Abnormal point / Condition	Condition	Remedy
		LED1(Red)	LED2(Yellow)			
1	Outdoor unit does not operate.	Lighting	Once	LEV and drain pump	The indoor unit detects an abnormality in the LEV and drain pump.	<ul style="list-style-type: none"> Refer to 13-6.⑩ "Check of LEV". Check the drain pump of the indoor unit.
2		Lighting	Twice	Outdoor power system	Overcurrent protection cut-out operates 3 consecutive times within 1 minute after the compressor gets started, or converter protection cut-out or bus-bar voltage protection cut-out operates 3 consecutive times within 3 minutes after start-up.	<ul style="list-style-type: none"> Check the connection of the compressor connecting wire. Refer to 13-6.⑪ "How to check inverter/compressor". Check the stop valve.
3		Lighting	3 times	Discharge temperature thermistor	A short circuit is detected in the thermistor during operation, or an open circuit is detected in the thermistor after 10 minutes of compressor start-up.	<ul style="list-style-type: none"> Refer to 13-6.⑫ "Check of outdoor thermistors".
4		Lighting	4 times	Fin temperature thermistor P.C board temperature thermistor	A short or open circuit is detected in the thermistor during operation.	<ul style="list-style-type: none"> Refer to 13-6.⑬ "Check of outdoor thermistors". Replace the outdoor electronic control P.C. board.
5		Lighting	5 times	Ambient temperature thermistor Outdoor heat exchanger temperature thermistor Defrost thermistor	A short or open circuit is detected in the thermistor during operation. A short circuit is detected in the thermistor during operation, or an open circuit is detected in the thermistor after 5 minutes (in cooling) and 10 minutes (in heating) of compressor start-up. A short circuit is detected in the thermistor during operation, or an open circuit is detected in the thermistor after 5 minutes of compressor start-up.	<ul style="list-style-type: none"> Refer to 13-6.⑭ "Check of outdoor thermistors".
6		Lighting	7 times	Nonvolatile memory data	The nonvolatile memory data cannot be read properly.	<ul style="list-style-type: none"> Replace the outdoor electronic control P.C. board.
7		Lighting	8 times	Current sensor	Current sensor protection stop is continuously performed twice.	<ul style="list-style-type: none"> Replace the power board.
8		Lighting	10 times	Gas pipe temperature thermistor A Gas pipe temperature thermistor B Gas pipe temperature thermistor C Gas pipe temperature thermistor D	A short or open circuit is detected in the thermistor during cooling. (A,B,C : MXZ-3A54VA-①,②,③, MXZ-4A71VA-①,②,③, MXZ-4A80VA-①) (D : MXZ-4A71VA-①,②,③, MXZ-4A80VA-①)	<ul style="list-style-type: none"> Refer to 13-6.⑮ "Check of outdoor thermistors".
9		Lighting	11 times	Communication error between P.C. boards	Communication error occurs twice between the outdoor electronic control P.C. board and power board for more than 10 seconds.	<ul style="list-style-type: none"> Check the connecting wire between outdoor electronic control P.C. board and power board.
10		Lighting	12 times	Zero cross detecting circuit	The protection stop of the zero cross detecting circuit is continuously performed 10 times.	<ul style="list-style-type: none"> Check the connecting wire among outdoor electronic control P.C. board, noise filter P.C. board and power board.
11	'Outdoor unit stops and restarts 3 minutes later' is repeated.	Twice	Goes out	IPM protection	Overcurrent is detected after 30 seconds of compressor start-up.	<ul style="list-style-type: none"> Reconnect compressor connector. Refer to 13-6.⑯ "How to check inverter/compressor".
Lock protection				Overcurrent is detected within 30 seconds of compressor start-up	<ul style="list-style-type: none"> Check the stop valve. Check the power module (PAM module). 	
12		3 times	Goes out	Discharge temperature protection	Discharge temperature exceeds 116°C during operation. Compressor can restart if discharge temperature thermistor reads 100°C or less 3 minutes later.	<ul style="list-style-type: none"> Check the amount of gas and refrigerant circuit. Refer to 13-6. ⑩ "Check of LEV".
13		4 times	Goes out	Fin temperature protection P.C. board temperature protection	The fin temperature exceeds 89°C during operation. The P.C. board temperature exceeds 73°C (MXZ-3A54VA, MXZ-4A71VA)/ 87°C (MXZ-4A80VA, MXZ-5A100VA) during operation.	<ul style="list-style-type: none"> Check refrigerant circuit and refrigerant amount. Refer to 13-6.⑰ "Check of outdoor fan motor".
14		5 times	Goes out	High-pressure protection	High-pressure is detected with the high-pressure switch (HPS) during operation. (MXZ-4A80VA, MXZ-5A100VA) The outdoor heat exchanger temperature exceeds 70°C during cooling or indoor gas pipe temperature exceeds 70°C during heating.	<ul style="list-style-type: none"> Check the amount of gas and the refrigerant circuit. Check the stop valve.
15		8 times	Goes out	Converter protection	A failure is detected in the operation of the converter during operation.	<ul style="list-style-type: none"> Replace the power board.
16		9 times	Goes out	Bus-bar voltage protection (1)	The bus-bar voltage exceeds 400 V or falls to 200 V or below during compressor operating.	<ul style="list-style-type: none"> Check the voltage of power supply. Replace the power board or the outdoor electronic control P.C. board.
17				Bus-bar voltage protection (2)	The bus-bar voltage exceeds 400 V (MXZ-3A54VA, MXZ-4A71VA)/ 430 V (MXZ-4A80VA, MXZ-5A100VA) or falls to 50 V or below during compressor operating.	<ul style="list-style-type: none"> Refer to 13-6. ⑱ "Check of bus-bar voltage".
17		13 times	Goes out	Outdoor fan motor	Failure occurs continuously three times within 30 seconds after the fan gets started.	<ul style="list-style-type: none"> Refer to 13-6.⑲ "Check of outdoor fan motor".
18		Lighting	8 times	Current sensor protection	A short or open circuit is detected in the current sensor during compressor operating.	<ul style="list-style-type: none"> Replace the power board.
19	Lighting	11 times	Communication protection between P.C. boards	Communication error occurs between the outdoor electronic control P.C. board and power board for more than 10 seconds.	<ul style="list-style-type: none"> Check the connecting wire between outdoor electronic control P.C. board and power board. 	
20	Lighting	12 times	Zero cross detecting circuit protection	Zero cross signal cannot be detected while the compressor is operating.	<ul style="list-style-type: none"> Check the connecting wire among outdoor electronic control P.C. board, noise filter P.C. board and power board. 	

No.	Symptom	Indication		Abnormal point / Condition	Condition	Remedy
		LED1(Red)	LED2(Yellow)			
21	Outdoor unit operates.	Once	Lighting	Primary current protection	The input current exceeds 15 A (MXZ-3A54VA, MXZ-4A71VA)/17 A (MXZ-4A80VA)/18 A (MXZ-5A100VA).	These symptoms do not mean any abnormality of the product, but check the following points. <ul style="list-style-type: none"> • Check if indoor filters are clogged. • Check if refrigerant is short. • Check if indoor/outdoor unit air circulation is short cycled.
				Secondary current protection	The current of the compressor exceeds 12 A (MXZ-3A54VA, MXZ-4A71VA)/10 A (MXZ-4A80VA, MXZ-5A100VA).	
22	Twice	Lighting	High-pressure protection	The indoor gas pipe temperature exceeds 45°C during heating.		
			Defrosting in cooling	The indoor gas pipe temperature falls 3°C or below during cooling.		
23	3 times	Lighting	Discharge temperature protection	The discharge temperature exceeds 100°C during operation.	<ul style="list-style-type: none"> • Check refrigerant circuit and refrigerant amount. • Refer to 13-6.Ⓓ "Check of LEV". • Refer to 13-6.Ⓔ "Check of outdoor thermistors". 	
24	4 times	Lighting	Low discharge temperature protection	The frequency of the compressor is kept 80 Hz or more and the discharge temperature is kept under 50°C (COOL mode) /40°C (HEAT mode) for more than 40 minutes.	<ul style="list-style-type: none"> • Refer to 13-6.Ⓓ "Check of LEV". • Check refrigerant circuit and refrigerant amount. 	
25	5 times	Lighting	Cooling high-pressure protection	The outdoor heat exchanger temperature exceeds 58°C during operation.	This symptom does not mean any abnormality of the product, but check the following points. <ul style="list-style-type: none"> • Check if indoor filters are clogged. • Check if refrigerant is short. • Check if indoor/outdoor unit air circulation is short cycled. 	
26	Outdoor unit operates normally.	9 times	Lighting	Inverter check mode	The unit is operated with emergency operation switch.	—
27		Lighting	Lighting	Normal	—	—

NOTE 1. The location of LED is illustrated at the right figure. Refer to 13-7.2.
 2. LED is lighted during normal operation.

The flashing frequency shows the number of times the LED blinks after every 2.5-second OFF.
 (Example) When the flashing frequency is "2".

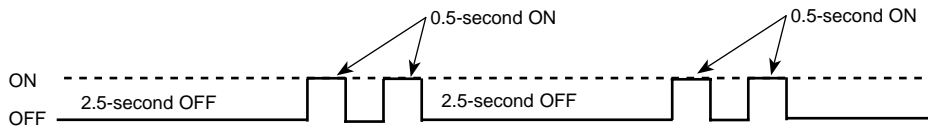

Outdoor electronic control P.C. board(Parts side)
 MXZ-3A54VA, MXZ-4A71VA, MXZ-4A80VA- [E]

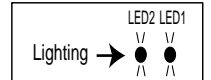

MXZ-4A80VA- [E2], MXZ-5A100VA

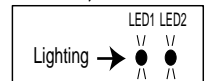

13-5. TROUBLE CRITERION OF MAIN PARTS

MXZ-2A30VA MXZ-2A40VA MXZ-2A52VA MXZ-3A54VA MXZ-4A71VA MXZ-4A80VA MXZ-5A100VA

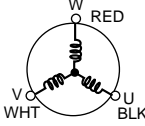
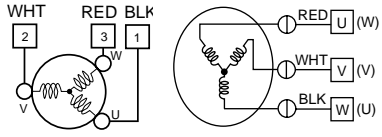
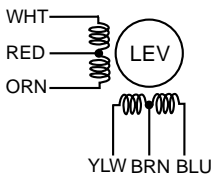
Part name	Check method and criterion															
Defrost thermistor (RT61) Fin temperature thermistor (RT64) Ambient temperature thermistor (RT65) Outdoor heat exchanger temperature thermistor (RT68)	Measure the resistance with a tester. Refer to 13-7. "Test point diagram and voltage", 1. "Inverter P.C. board", 2. "Outdoor electronic control P.C. board" or 5. "Outdoor Power board", for the chart of thermistor.															
Gas pipe temperature thermistor (RT6A~D) MXZ-3A54VA- E1, E2, E3 MXZ-4A71VA- E1, E2, E3 MXZ-4A80VA- E1																
Discharge temperature thermistor (RT62)	Measure the resistance with a tester. Before measurement, hold the thermistor with your hands to warm it up. Refer to 13-7. "Test point diagram and voltage", 1. "Inverter P.C. board" or 2. "Outdoor electronic control P.C. board", for the chart of thermistor.															
Compressor 	Measure the resistance between terminals using a tester. (Winding temperature : -10°C ~ 40°C) <table border="1" style="margin-top: 10px;"> <thead> <tr> <th colspan="5">Normal (Each phase)</th> </tr> </thead> <tbody> <tr> <td>2A30VA 2A40VA- E2</td> <td>2A40VA- E1 2A52VA</td> <td>3A54VA - E1, E2, E3 4A71VA - E1, E2, E3</td> <td>3A54VA - E4, E5, E6, E7 4A71VA - E4, E5, E6, E7</td> <td>4A80VA 5A100VA</td> </tr> <tr> <td>1.49 Ω ~ 1.84 Ω</td> <td>0.56 Ω ~ 0.69 Ω</td> <td>0.39 Ω ~ 0.49 Ω</td> <td>0.86 Ω ~ 1.06 Ω</td> <td>1.29 Ω ~ 1.49 Ω</td> </tr> </tbody> </table>	Normal (Each phase)					2A30VA 2A40VA- E2	2A40VA- E1 2A52VA	3A54VA - E1, E2, E3 4A71VA - E1, E2, E3	3A54VA - E4, E5, E6, E7 4A71VA - E4, E5, E6, E7	4A80VA 5A100VA	1.49 Ω ~ 1.84 Ω	0.56 Ω ~ 0.69 Ω	0.39 Ω ~ 0.49 Ω	0.86 Ω ~ 1.06 Ω	1.29 Ω ~ 1.49 Ω
Normal (Each phase)																
2A30VA 2A40VA- E2	2A40VA- E1 2A52VA	3A54VA - E1, E2, E3 4A71VA - E1, E2, E3	3A54VA - E4, E5, E6, E7 4A71VA - E4, E5, E6, E7	4A80VA 5A100VA												
1.49 Ω ~ 1.84 Ω	0.56 Ω ~ 0.69 Ω	0.39 Ω ~ 0.49 Ω	0.86 Ω ~ 1.06 Ω	1.29 Ω ~ 1.49 Ω												
Outdoor fan motor 	Measure the resistance between lead wires using a tester. (Part temperature : -10°C ~ 40°C) <table border="1" style="margin-top: 10px;"> <thead> <tr> <th colspan="2">Normal (Each phase)</th> </tr> </thead> <tbody> <tr> <td>MXZ-2A</td> <td>MXZ-3A/4A/5A</td> </tr> <tr> <td>12 Ω ~ 16 Ω</td> <td>13.4 Ω ~ 16.4 Ω</td> </tr> </tbody> </table>	Normal (Each phase)		MXZ-2A	MXZ-3A/4A/5A	12 Ω ~ 16 Ω	13.4 Ω ~ 16.4 Ω									
Normal (Each phase)																
MXZ-2A	MXZ-3A/4A/5A															
12 Ω ~ 16 Ω	13.4 Ω ~ 16.4 Ω															
R.V. coil	Measure the resistance using a tester. (Part temperature : -10°C ~ 40°C) <table border="1" style="margin-top: 10px;"> <thead> <tr> <th colspan="2">Normal (Each phase)</th> </tr> </thead> <tbody> <tr> <td>MXZ-3A54VA - E4, E5, E6, E7 MXZ-4A71VA - E4, E5, E6, E7</td> <td>Other models</td> </tr> <tr> <td>1.26 kΩ ~ 1.62 kΩ</td> <td>1.2 kΩ ~ 1.56 kΩ</td> </tr> </tbody> </table>	Normal (Each phase)		MXZ-3A54VA - E4, E5, E6, E7 MXZ-4A71VA - E4, E5, E6, E7	Other models	1.26 kΩ ~ 1.62 kΩ	1.2 kΩ ~ 1.56 kΩ									
Normal (Each phase)																
MXZ-3A54VA - E4, E5, E6, E7 MXZ-4A71VA - E4, E5, E6, E7	Other models															
1.26 kΩ ~ 1.62 kΩ	1.2 kΩ ~ 1.56 kΩ															
Linear expansion valve 	Measure the resistance using a tester. (Part temperature : -10°C ~ 40°C) <table border="1" style="margin-top: 10px;"> <thead> <tr> <th>Color of lead wire</th> <th>Normal</th> </tr> </thead> <tbody> <tr> <td>WHT - RED</td> <td rowspan="4">37.4 Ω ~ 53.9 Ω</td> </tr> <tr> <td>RED - ORN</td> </tr> <tr> <td>YLW - BRN</td> </tr> <tr> <td>BRN - BLU</td> </tr> </tbody> </table>	Color of lead wire	Normal	WHT - RED	37.4 Ω ~ 53.9 Ω	RED - ORN	YLW - BRN	BRN - BLU								
Color of lead wire	Normal															
WHT - RED	37.4 Ω ~ 53.9 Ω															
RED - ORN																
YLW - BRN																
BRN - BLU																
High pressure switch (HPS) MXZ-4A80/5A100	<table border="1" style="margin-top: 10px;"> <thead> <tr> <th colspan="2">Pressure</th> <th>Normal</th> </tr> </thead> <tbody> <tr> <td rowspan="2">HPS</td> <td>3.7 ± 0.15 MPa</td> <td>Close</td> </tr> <tr> <td>4.8 ±_{0.1}^{0.05} MPa</td> <td>Open</td> </tr> </tbody> </table>	Pressure		Normal	HPS	3.7 ± 0.15 MPa	Close	4.8 ± _{0.1} ^{0.05} MPa	Open							
Pressure		Normal														
HPS	3.7 ± 0.15 MPa	Close														
	4.8 ± _{0.1} ^{0.05} MPa	Open														

13-6. TROUBLESHOOTING FLOW

Outdoor unit does not operate.

Ⓐ Check of power supply

MXZ-2A30/2A40/2A52

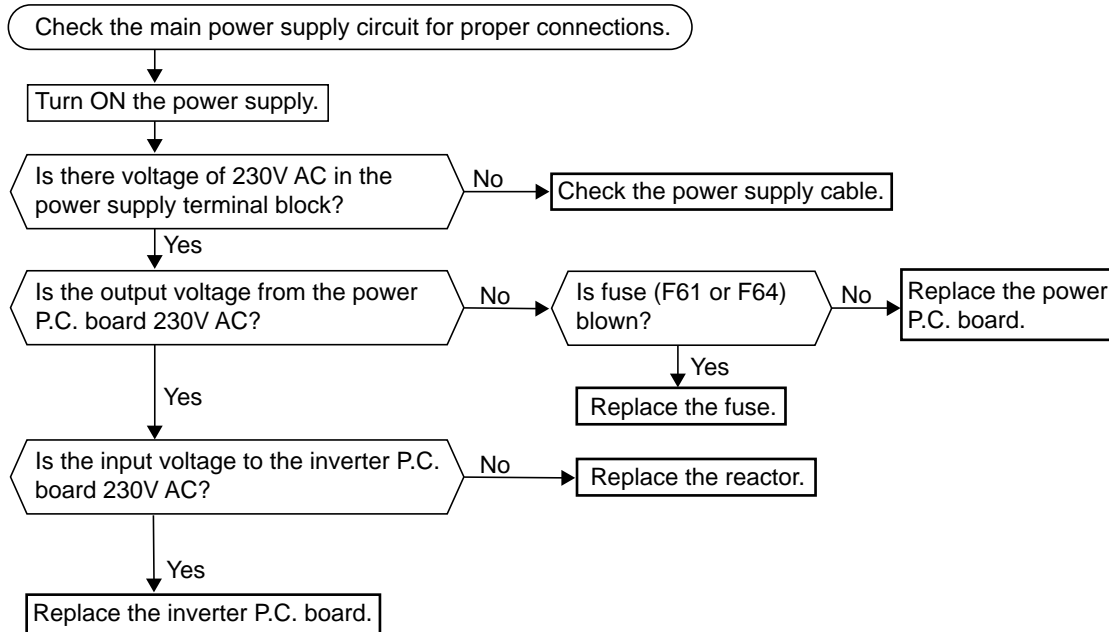

MXZ-3A54/4A71/4A80/5A100

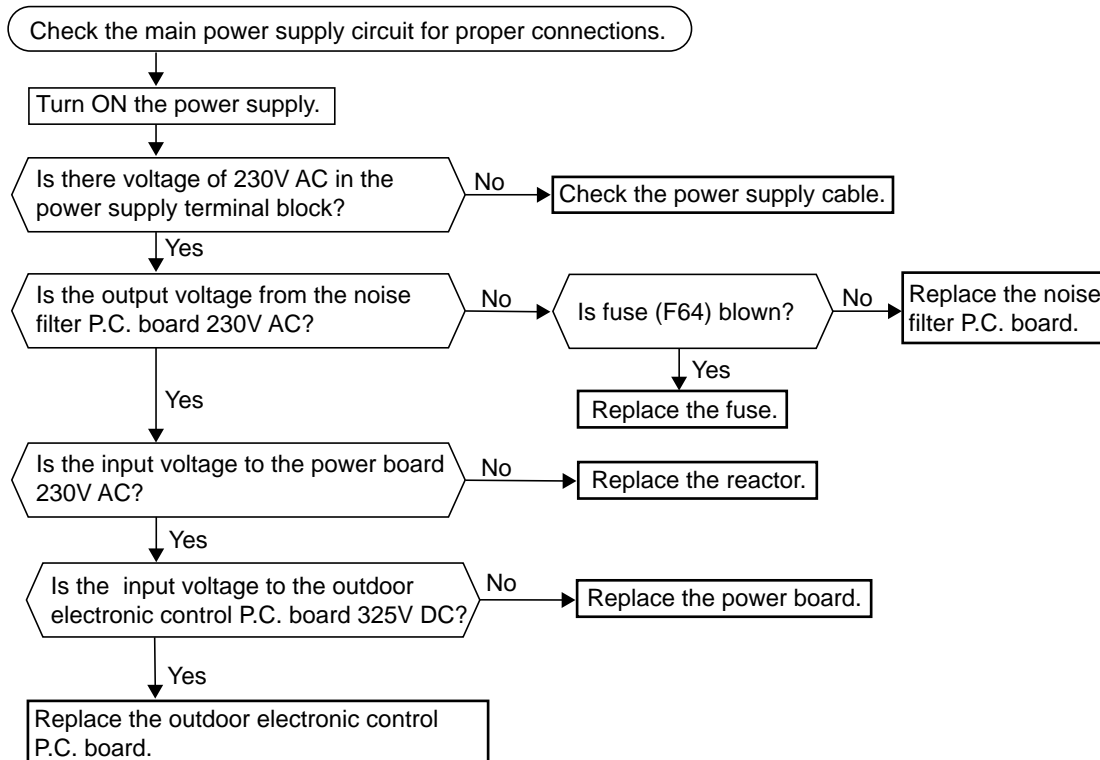

- When unit cannot operate neither by the remote controller nor by EMERGENCY OPERATION switch. Indoor unit does not operate.
- When OPERATION INDICATOR lamp flashes ON and OFF in every 0.5-second. Outdoor unit does not operate.

Ⓑ How to check miswiring and serial signal error (when outdoor unit does not work)

LED indication for communication status

Communication status is indicated by the LED.

Unit status

Blinking: normal communication
Lighting: abnormal communication or not connected

Pattern 1 and 2 is repeatedly displayed alternately. Each pattern is displayed for 15 seconds.

NOTE: "Lighting" in the table below does not indicate abnormal communication.

MXZ-2A52VA

Outdoor display P.C. board

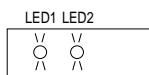

Blinking

LED 1	LED 2
Unit A status	Unit B status

MXZ-3A54VA

MXZ-4A71VA

MXZ-4A80VA -[E1]

Outdoor electronic control P.C. board (Parts side)

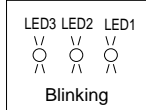

Blinking

Pattern	LED 3	LED 2	LED 1
1	Lighting	Unit B status	Unit A status
2	Goes out	Unit D status	Unit C status

MXZ-4A80VA -[E2]

MXZ-5A100VA

Outdoor electronic control P.C. board (Parts side)

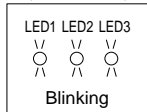

Blinking

Pattern	LED 1	LED 2	LED 3
1	Unit A status	Unit B status	Unit C status
2	Unit D status	Unit E status	Goes out

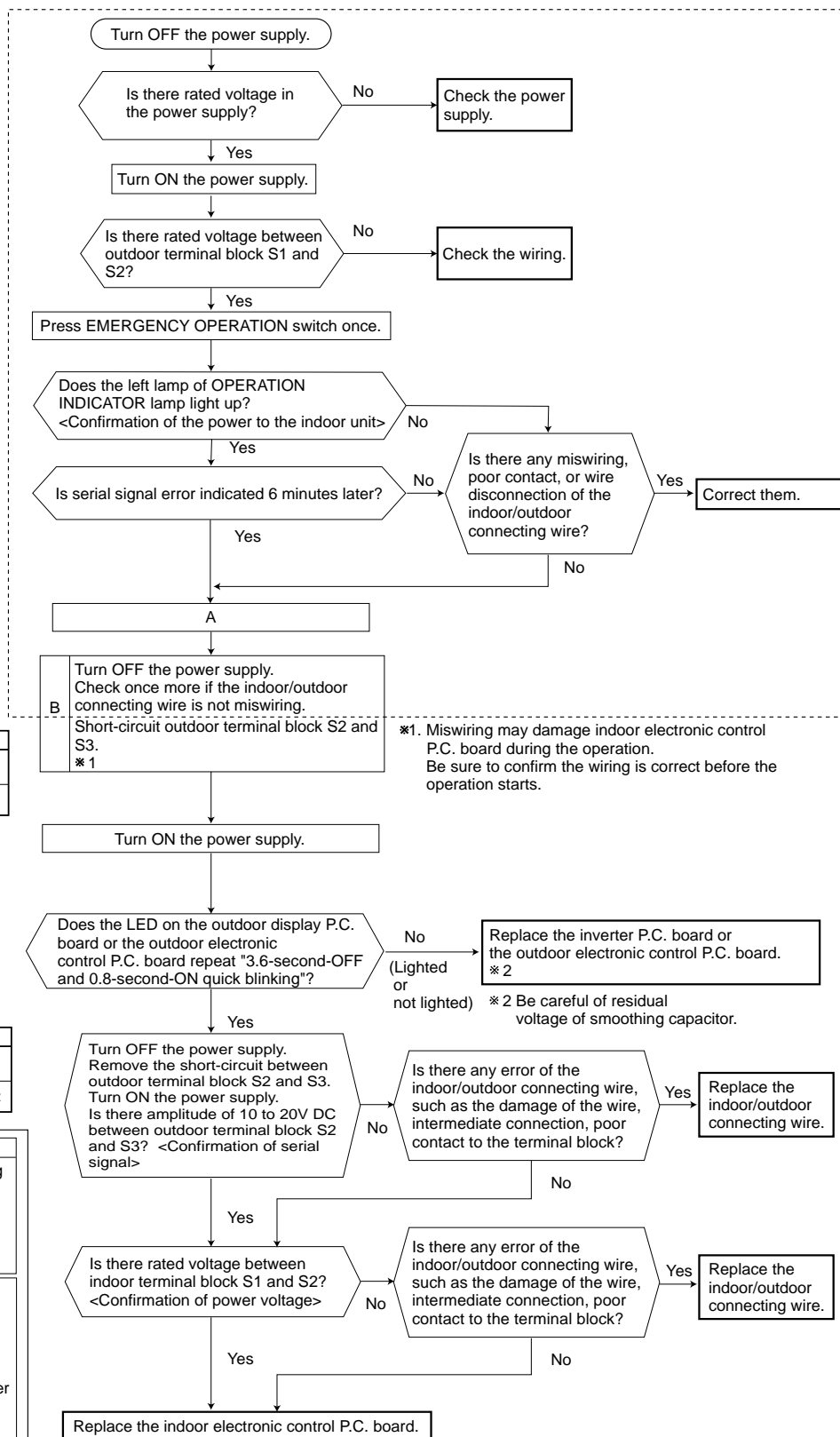

*1. Miswiring may damage indoor electronic control P.C. board during the operation. Be sure to confirm the wiring is correct before the operation starts.

*2 Be careful of residual voltage of smoothing capacitor.

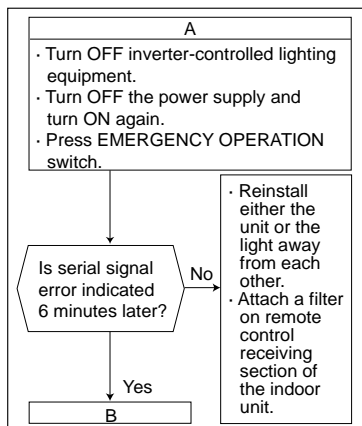

Be sure to release the failure-mode recall function after checking.

Refer to indoor unit service manual.

The cooling operation or heating operation does not operate.

© Check of R.V. coil

	MXZ-2A	MXZ-3A/4A/5A
CN912	Power P.C. board	Noise filter P.C. board
CN781	—————	Outdoor electronic control P.C. board
CN933	Inverter P.C. board	—————

• When heating operation does not work.

1. Disconnect the lead wire leading to the compressor.
2. 3 minutes after turning ON the power supply, start EMERGENCY OPERATION in HEAT mode.

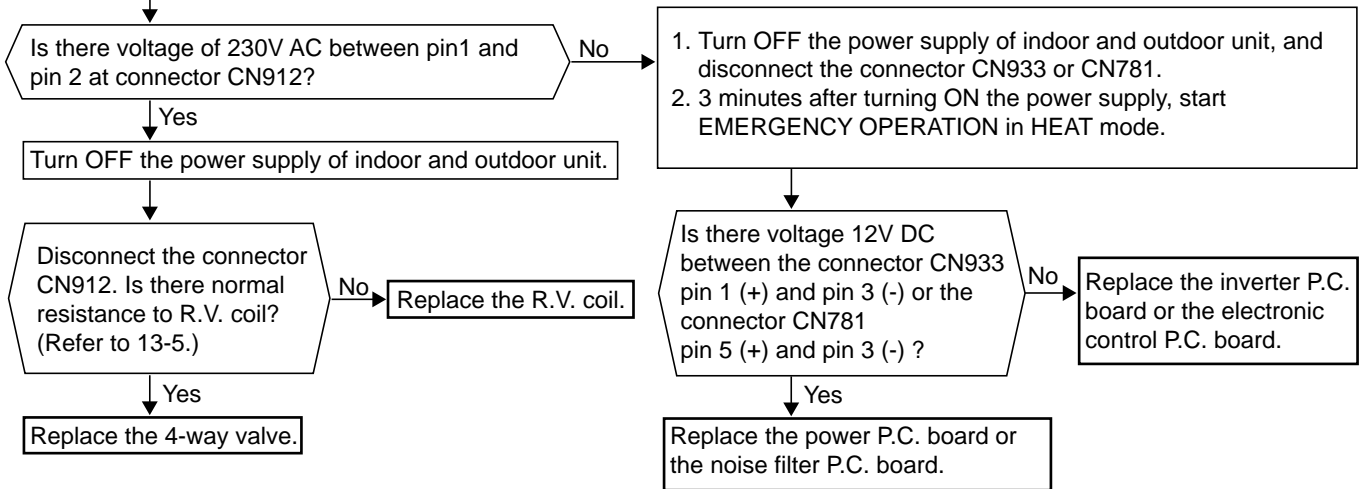

• When cooling operation does not work.

1. Disconnect the lead wire leading to the compressor.
2. 3 minutes after turning ON the power supply, start EMERGENCY OPERATION in COOL mode.

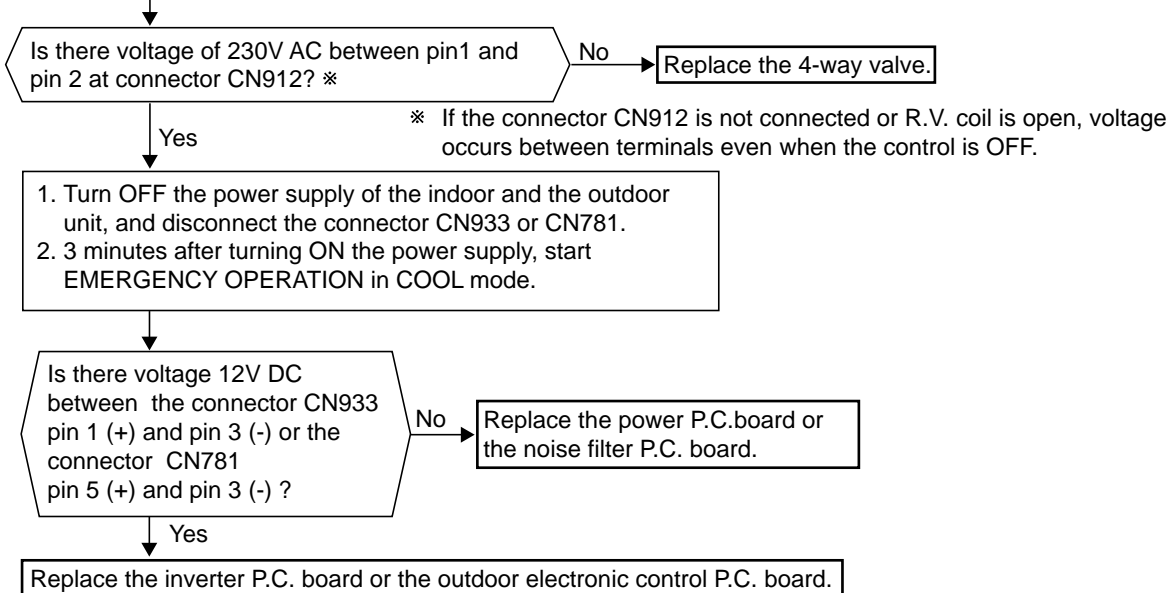



- When cooling, heat exchanger of non-operating indoor unit frosts.
- When heating, non-operating indoor unit gets warm.

① Check of LEV

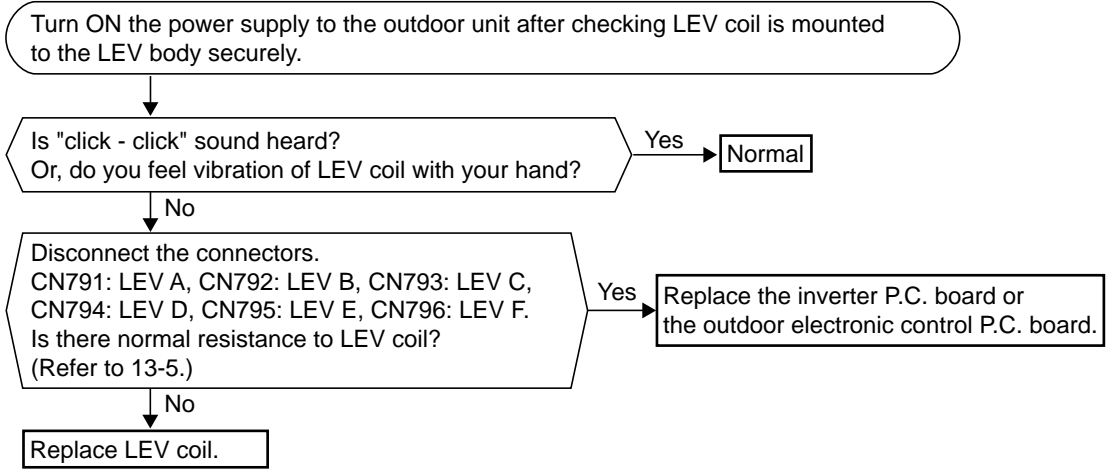

- When heating, room does not get warm.
- When cooling, room does not get cool.

Ⓔ How to check inverter/ compressor

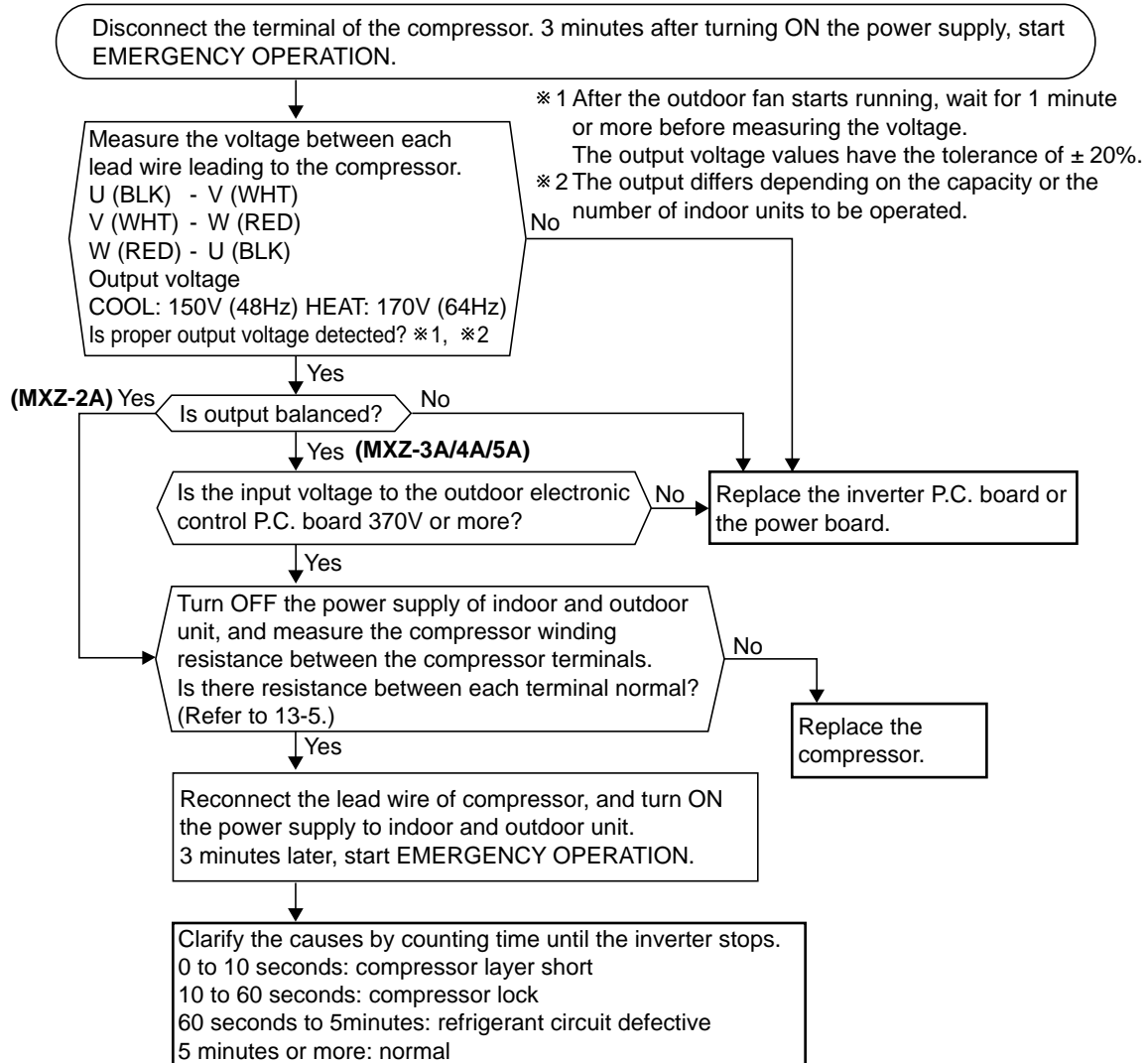

• When thermistor is abnormal.

Ⓔ Check of outdoor thermistors

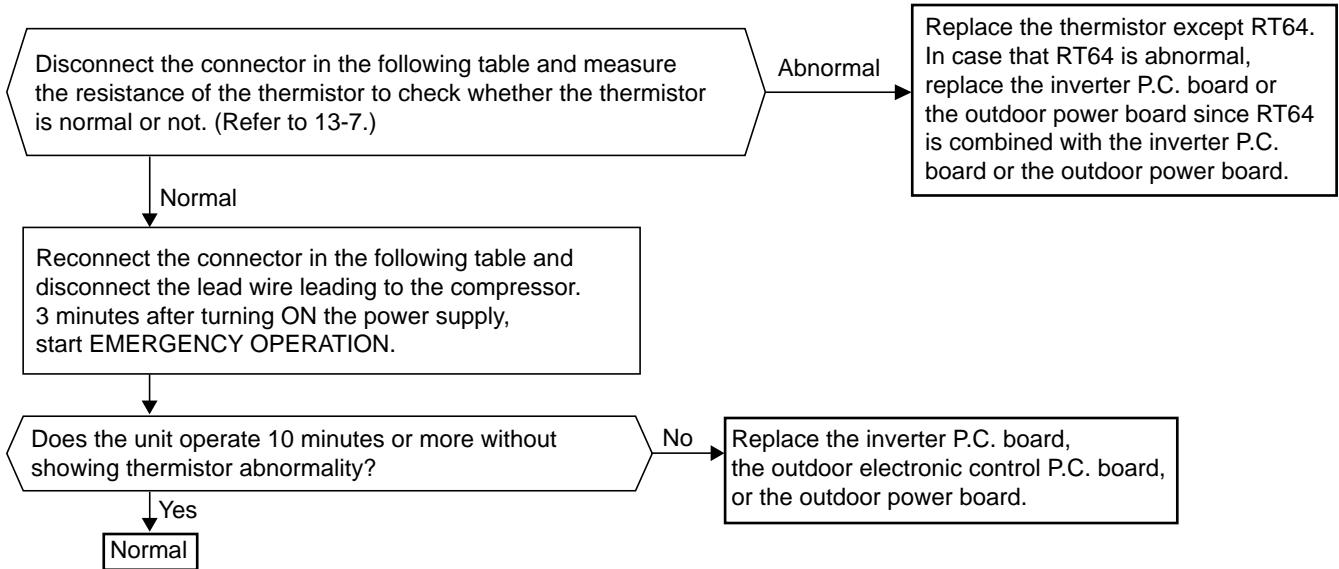

MXZ-2A30/2A40/2A52

Thermistor	Symbol	Connector, Pin No.	Board
Defrost	RT61	Between CN661 pin1 and pin2	Inverter P.C. board
Discharge temperature	RT62	Between CN661 pin3 and pin4	
Outdoor heat exchanger temperature	RT68	Between CN661 pin5 and pin6	
Fin temperature	RT64	Between CN662 pin1 and pin2	
Ambient temperature	RT65	Between CN663 pin1 and pin2	

MXZ-3A54/4A71/4A80/5A100

Thermistor	Symbol	Connector, Pin No.	Board
Defrost	RT61	Between CN661 pin1 and pin2	Outdoor electronic control P.C. board
Discharge temperature	RT62	Between CN661 pin3 and pin4	
Outdoor heat exchanger temperature	RT68	Between CN661 pin7 and pin8	
Gas pipe temperature (Unit A) ※	RT6A	Between CN662 pin1 and pin2	
Gas pipe temperature (Unit B) ※	RT6B	Between CN662 pin3 and pin4	
Gas pipe temperature (Unit C) ※	RT6C	Between CN662 pin5 and pin6	
Gas pipe temperature (Unit D) ※	RT6D	Between CN662 pin7 and pin8	
Ambient temperature	RT65	Between CN663 pin1 and pin2	Outdoor power board
Fin temperature	RT64	Between CN3 pin1 and pin2	

※ Except MXZ-3A54VA- E4, E5, E6, E7, MXZ-4A71VA- E4, E5, E6, E7, MXZ-4A80VA- E2 and MXZ-5A100VA.

• Fan motor does not operate or stops operating shortly after starting the operation.

③ Check of outdoor fan motor

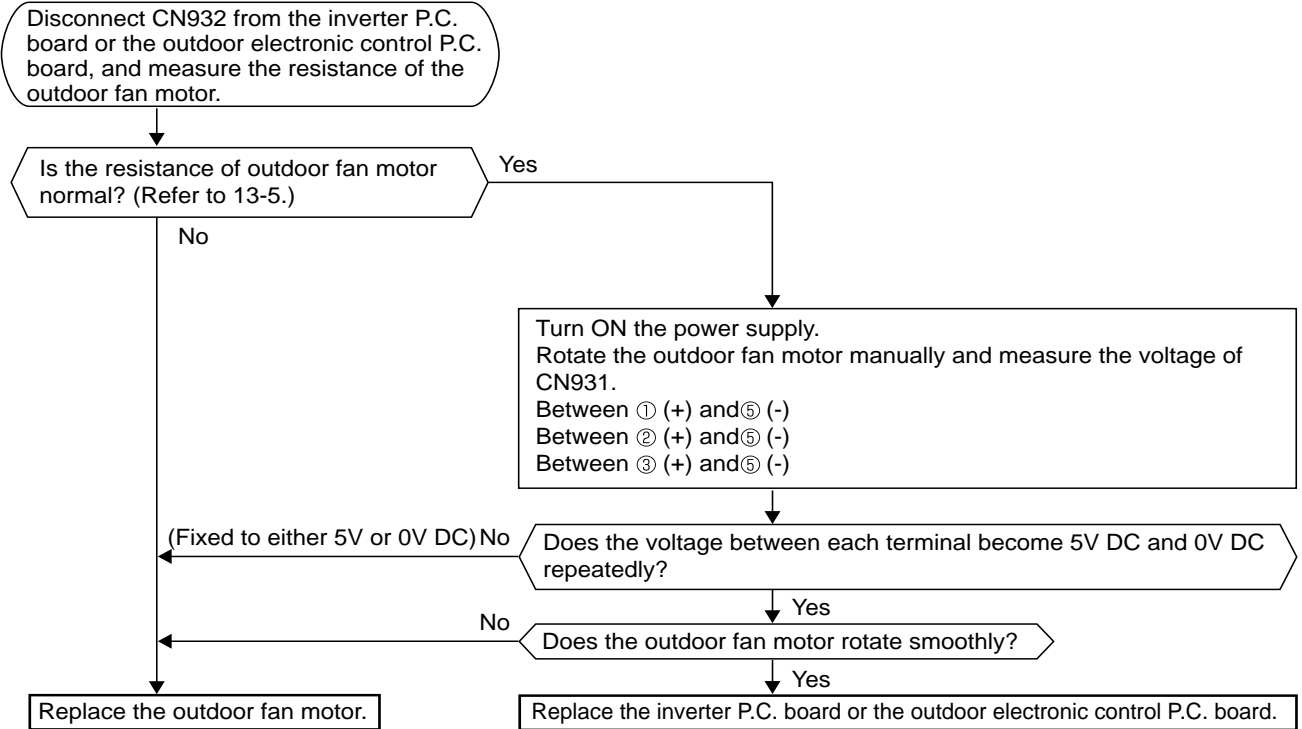

- When the operation frequency does not go up from lowest frequency.

⊕ Check of HPS

MXZ-4A80VA/5A100VA

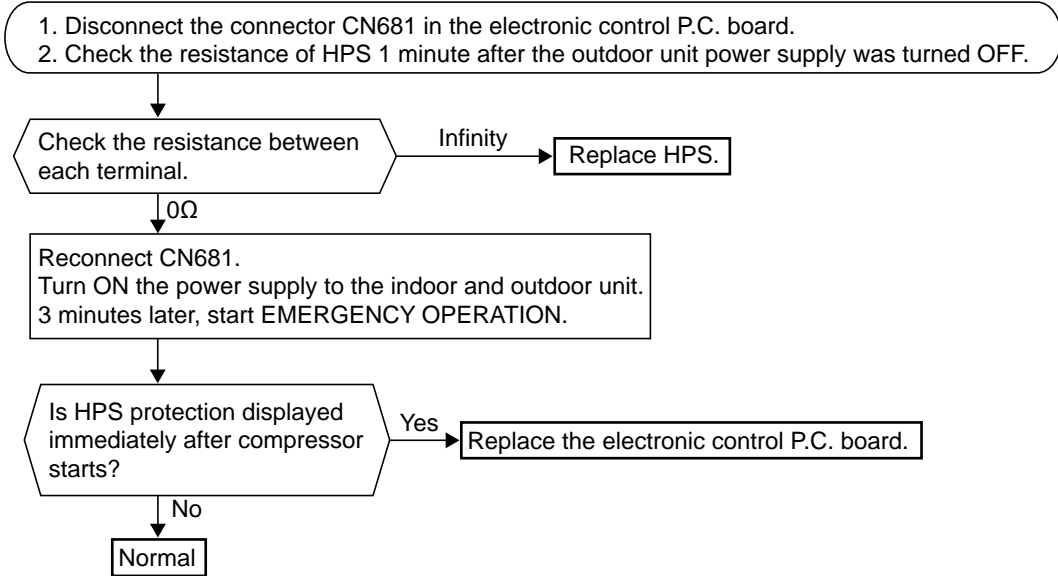

① The other cases

Indoor unit does not operate. (different operating models in multi system)

- When you try to run two indoor units simultaneously, one for cooling and the other for heating, the unit which transmits signal to the outdoor unit first decides the operation mode.
- When the above situation occurs, set all the indoor units to the same mode, turn OFF the indoor units, then turn them back ON.
- Though the top of the indoor unit sometimes gets warm, this does not mean malfunction. The reason is that the refrigerant gas continuously flows into the indoor unit even while it is not operating.

Ⓜ Check of bus-bar voltage

MXZ-3A/4A/5A

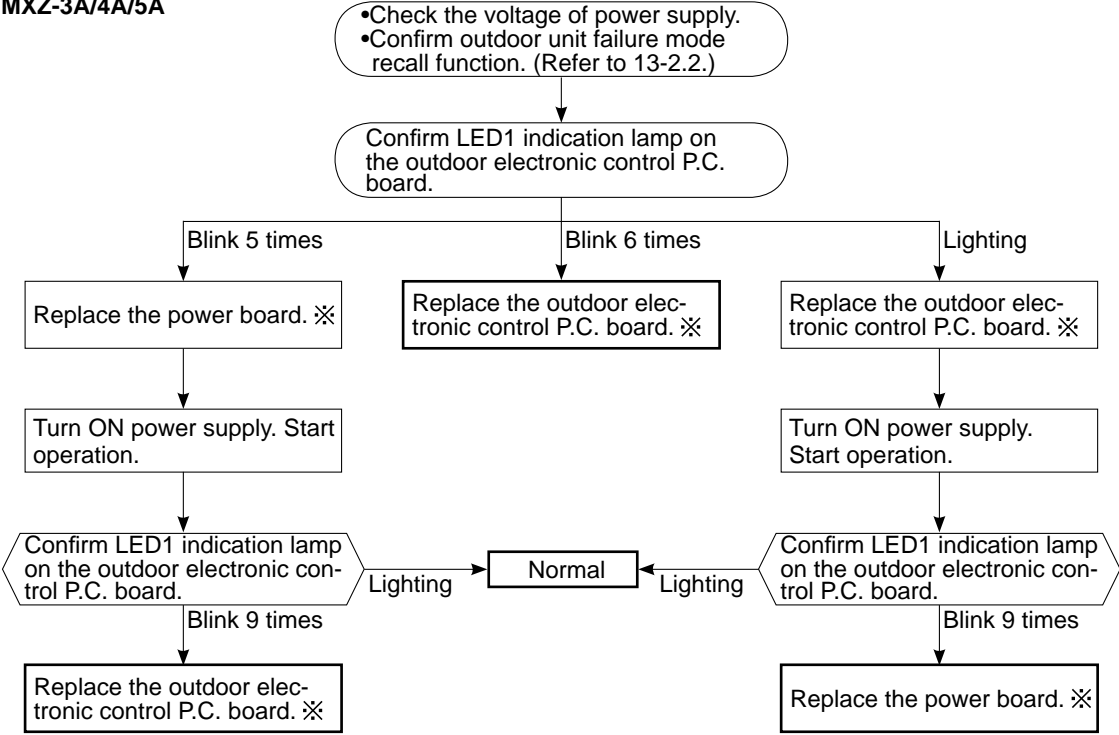

※ Turn OFF power supply before removing P.C. board.

13-7. TEST POINT DIAGRAM AND VOLTAGE

1. Inverter P.C. board

MXZ-2A30VA MXZ-2A40VA MXZ-2A52VA

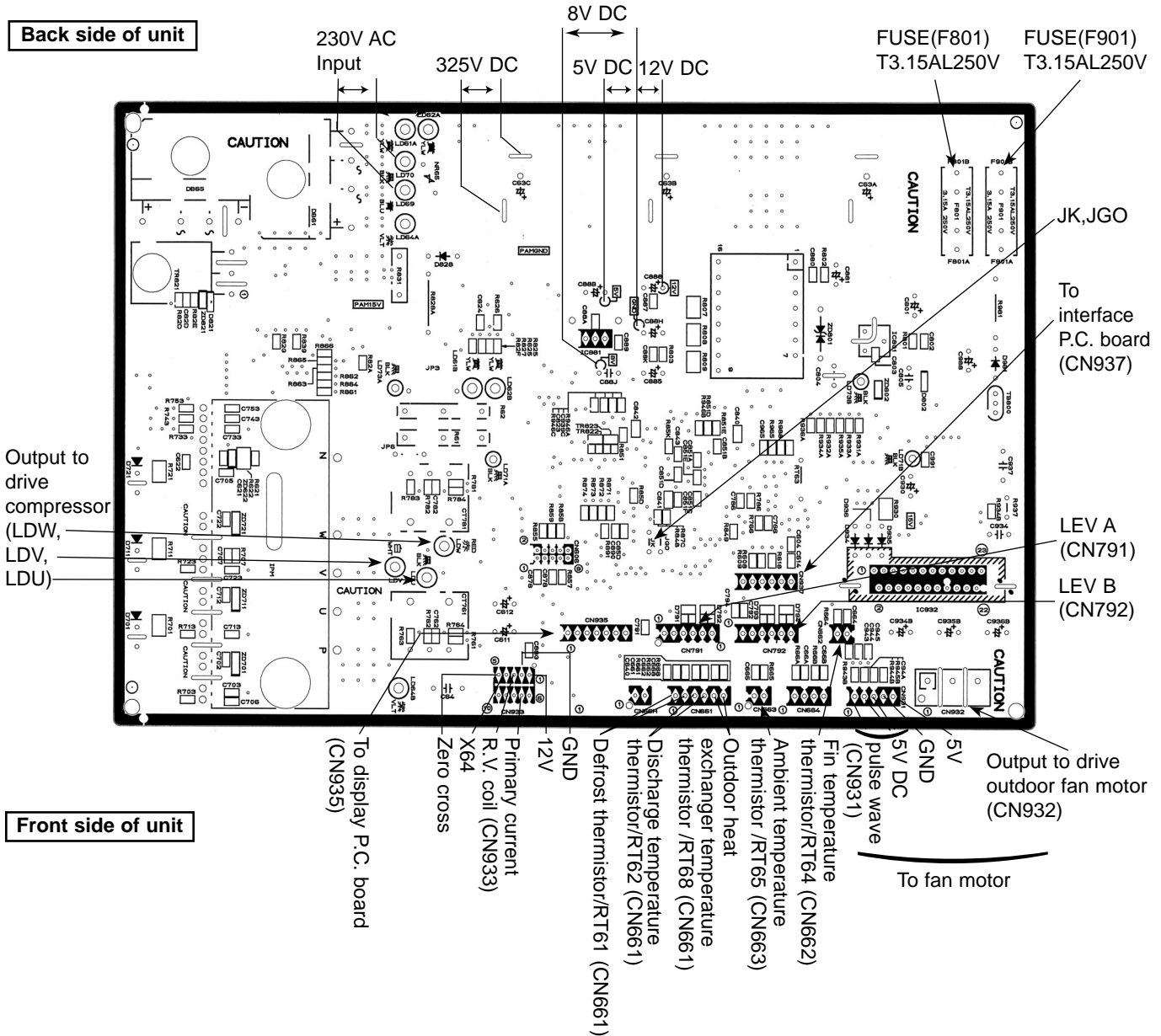

Defrost thermistor (RT61)
Ambient temperature thermistor (RT65)
Outdoor heat exchanger
temperature thermistor (RT68)

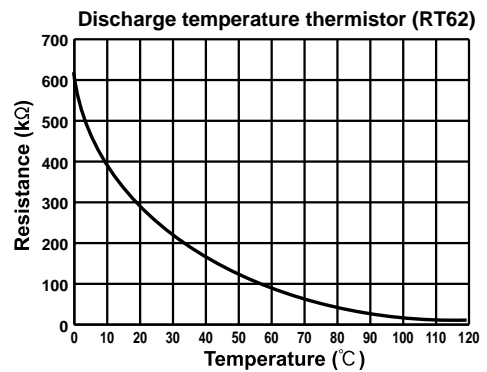
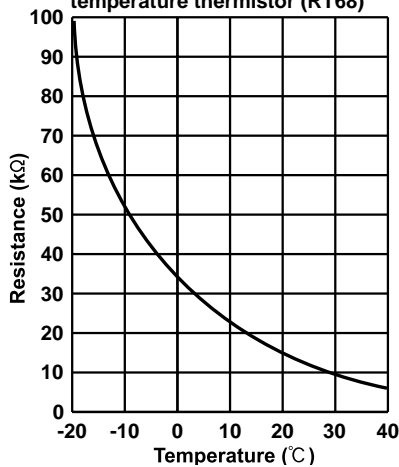
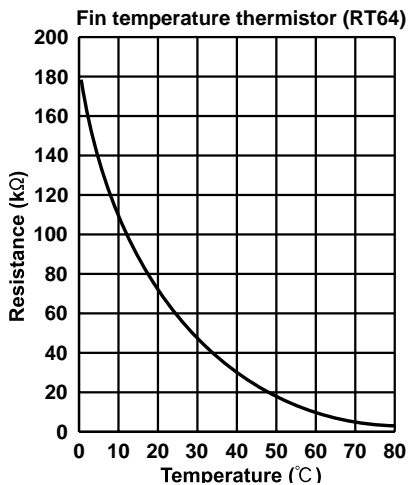

2. Outdoor electronic control P.C. board
MXZ-3A54VA MXZ-4A71VA MXZ-4A80VA - [E1]

Defrost thermistor (RT61)
 Ambient temperature thermistor (RT65)
 Gas pipe temperature thermistor (RT6A, 6B, 6C, 6D)
 (Except MXZ-3A54VA-[E4], [E5], [E6], [E7] and MXZ-4A71VA-[E4], [E5], [E6], [E7].)
 Outdoor heat exchanger temperature thermistor (RT68)

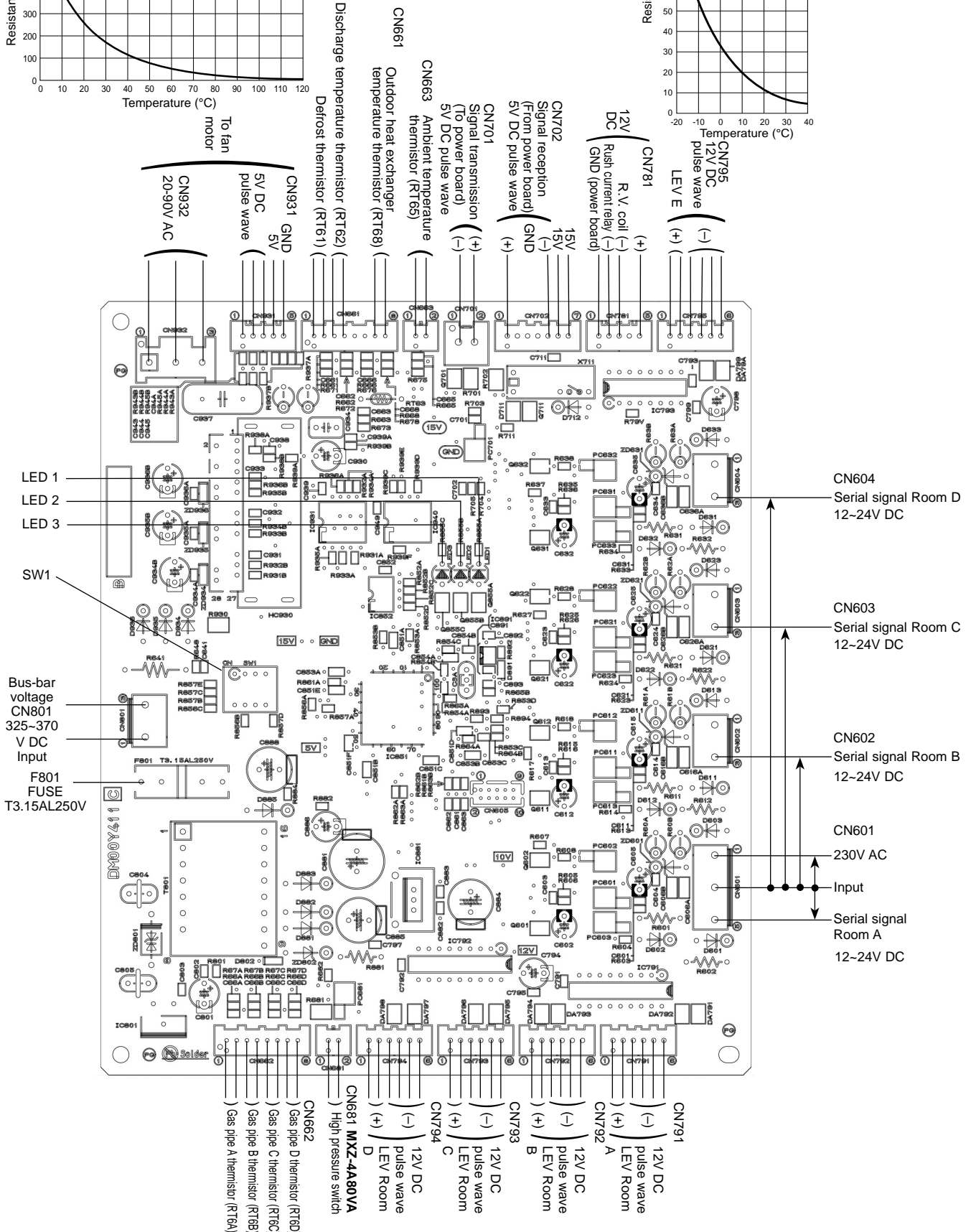
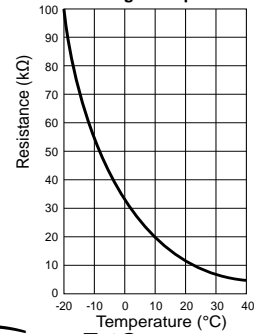
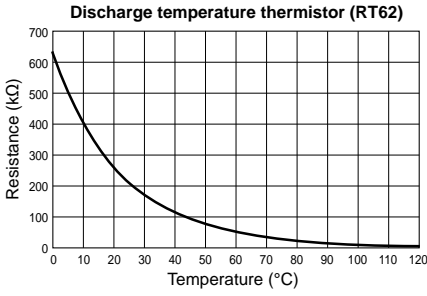

3. Noise filter P.C. board

MXZ-3A54VA - [E1], [E2], [E3], [E4] **MXZ-4A71VA - [E1], [E2], [E3], [E4]** **MXZ-4A80VA - [E1]**

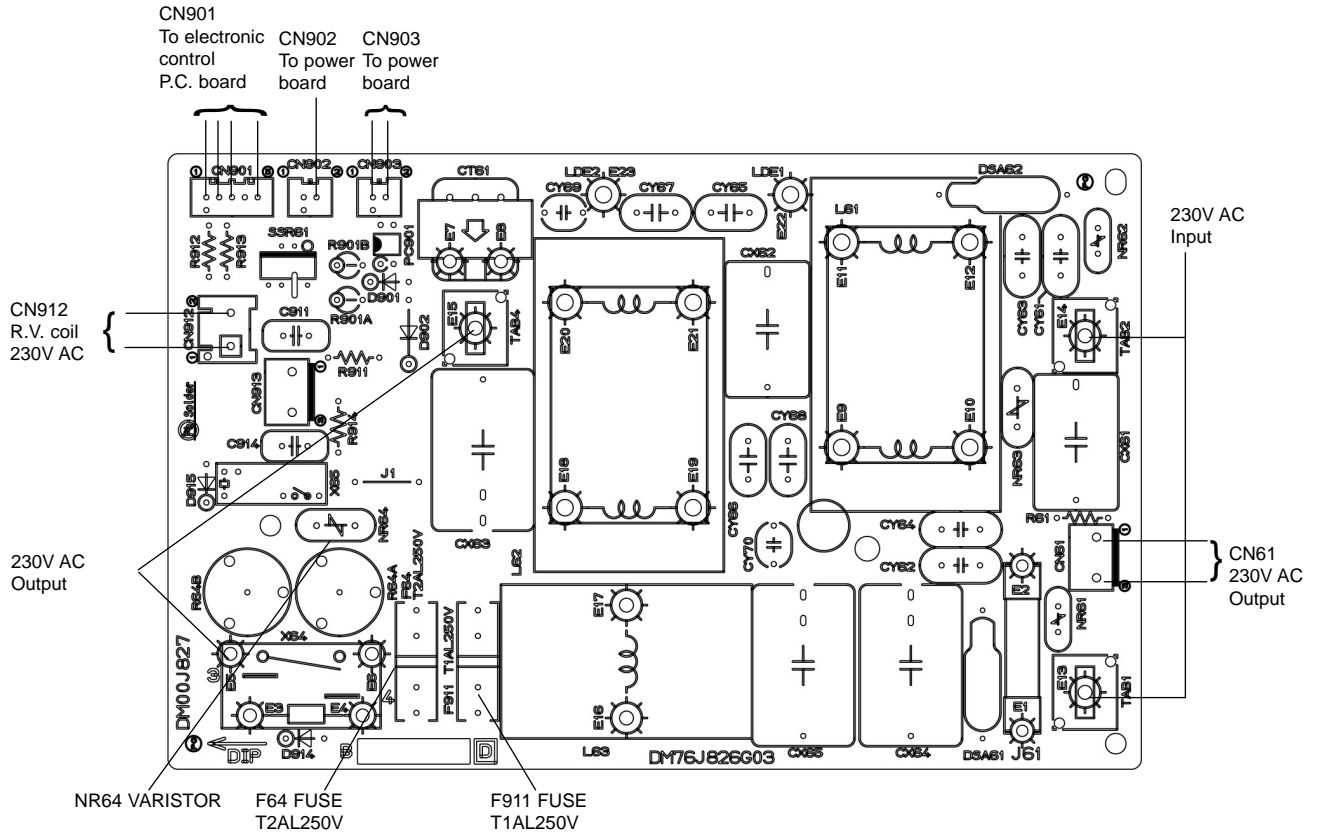

MXZ-3A54VA - [E5], [E6], [E7] **MXZ-4A71VA - [E5], [E6], [E7]**

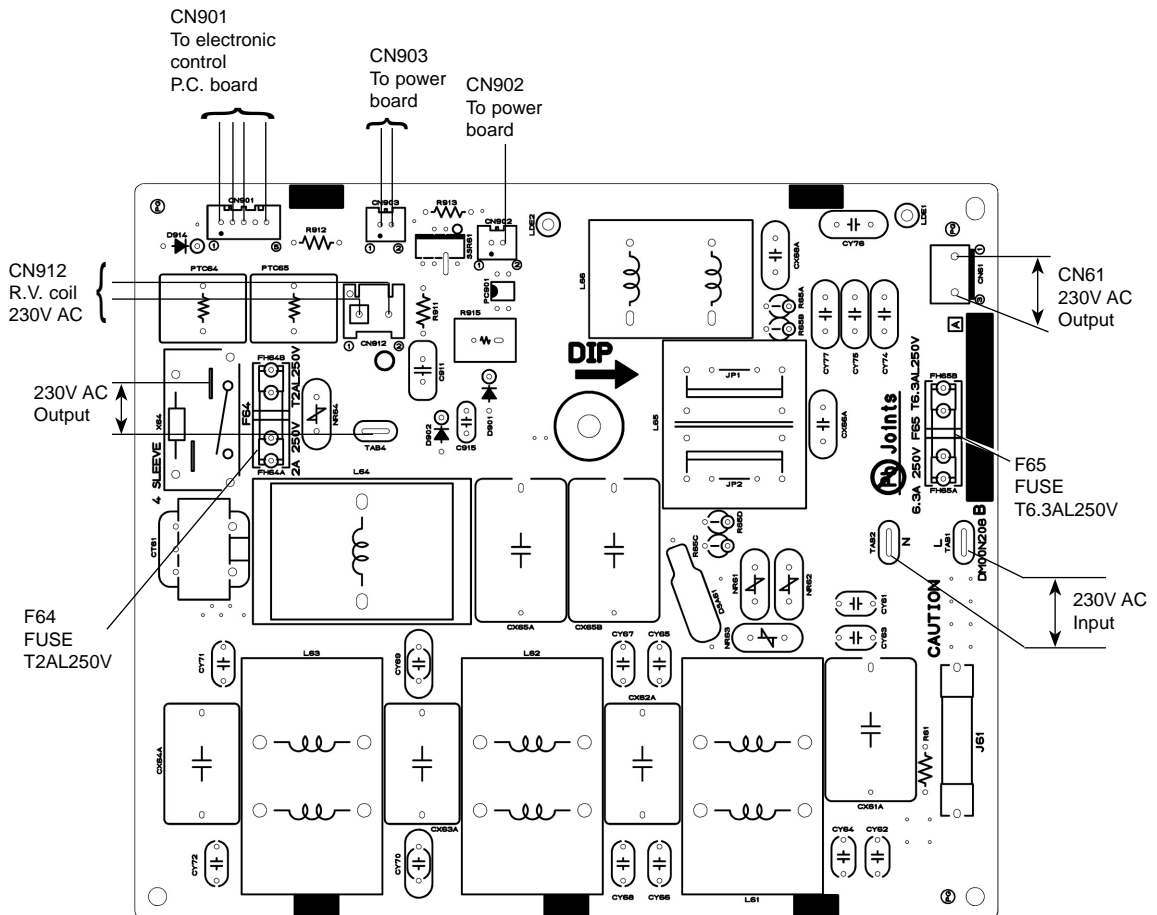

MXZ-4A80VA - E2 MXZ-5A100VA

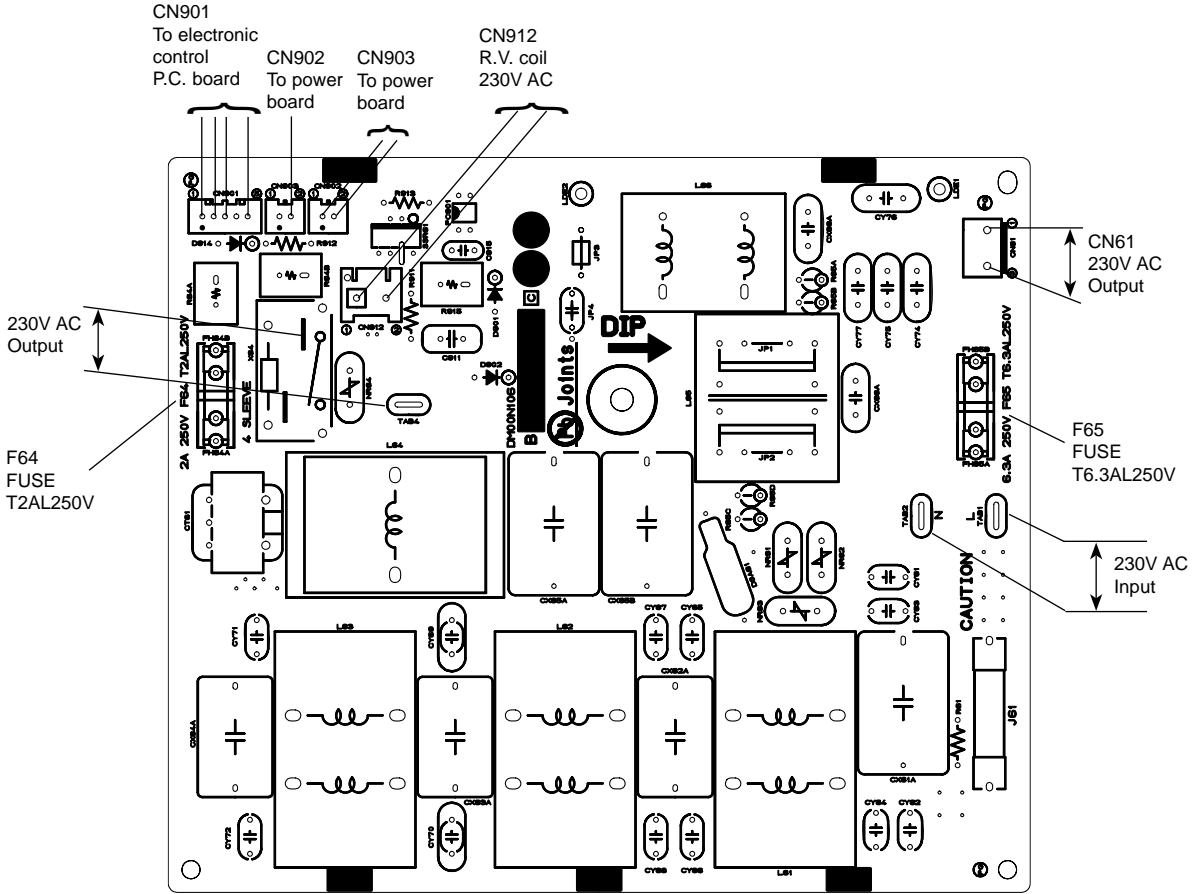

MXZ-2A30VA MXZ-2A40VA MXZ-2A52VA

Back side of unit

Front side of unit

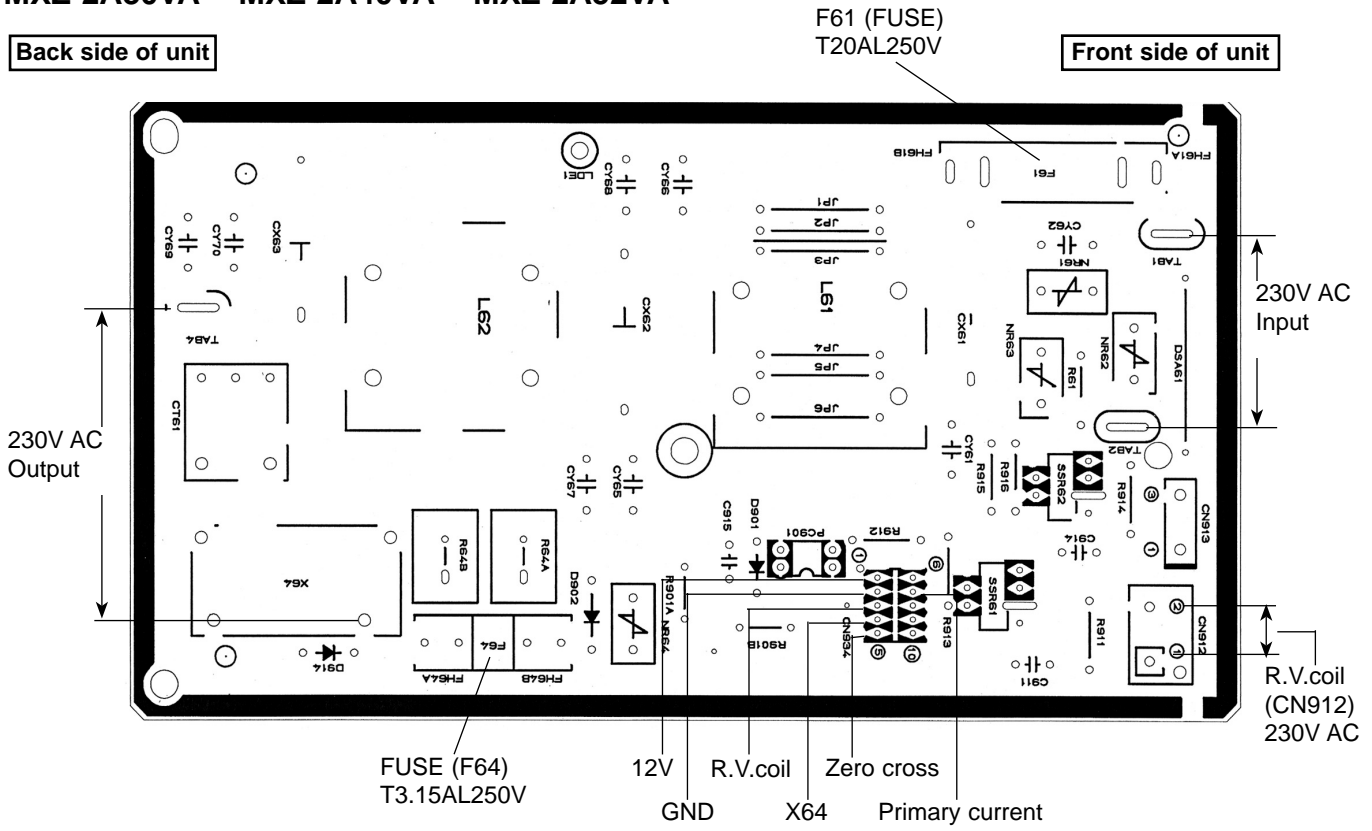

5. Outdoor Power board

MXZ-3A54VA MXZ-4A71VA MXZ-4A80VA MXZ-5A100VA

Fin temperature thermistor (RT64)

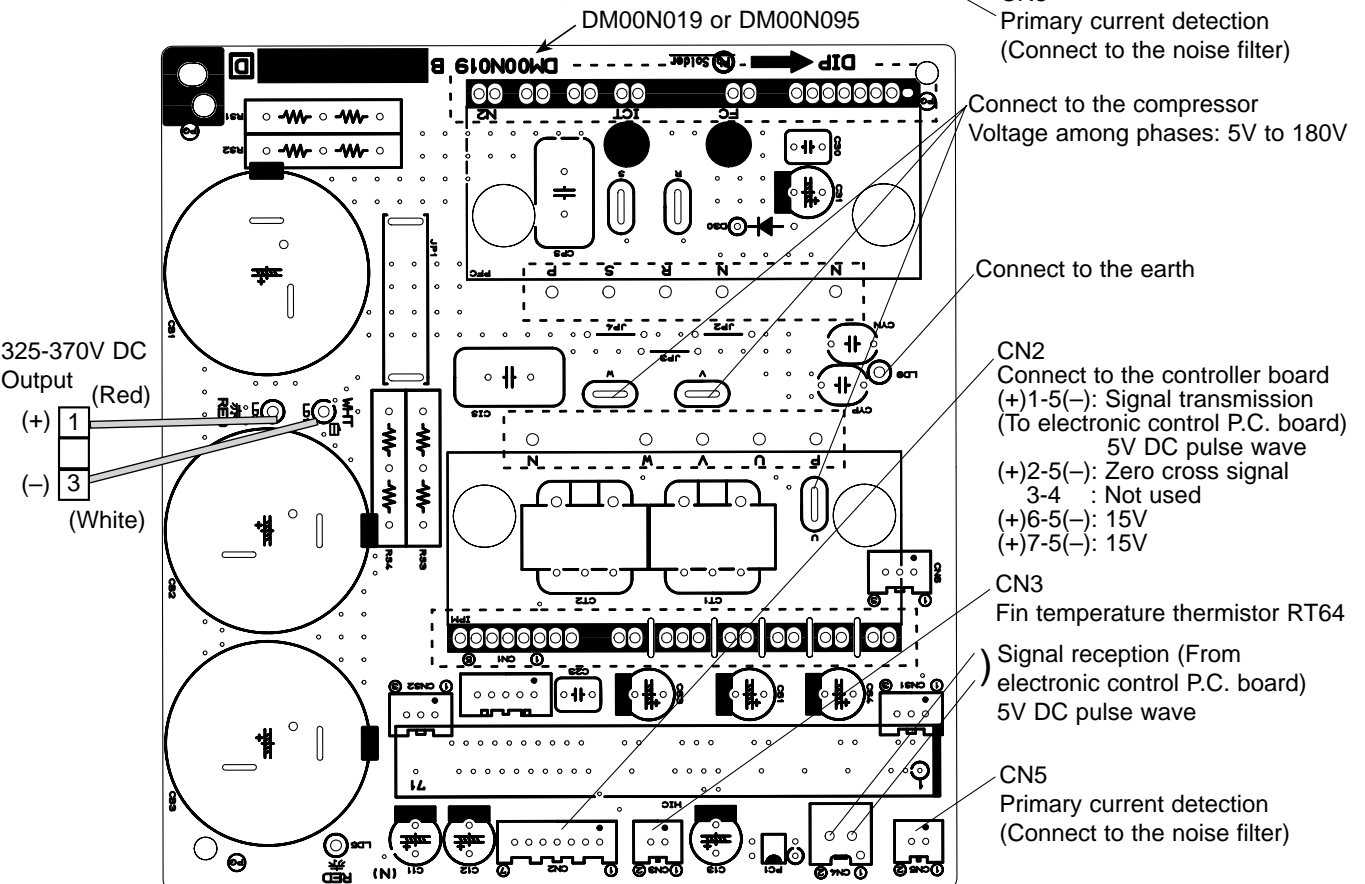
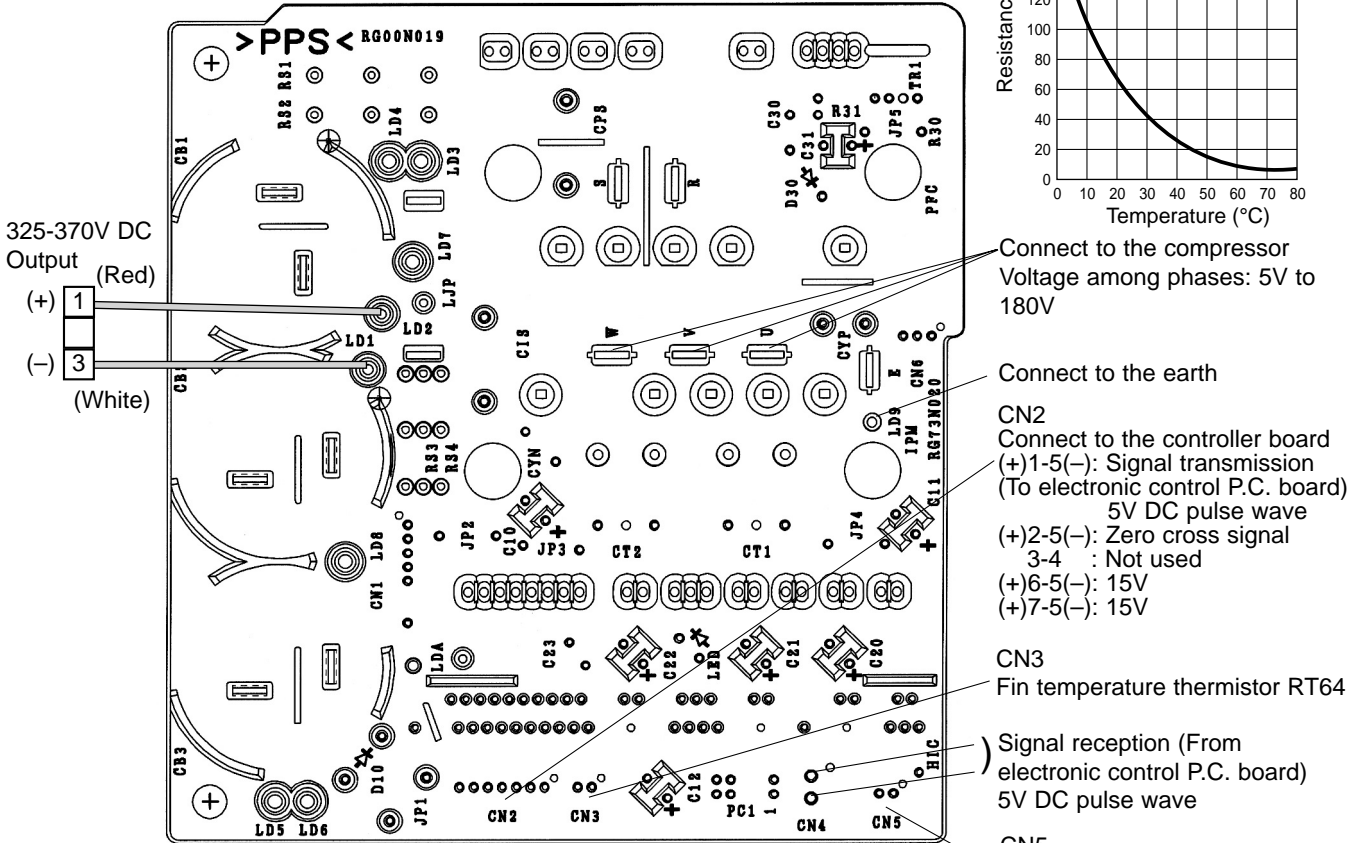
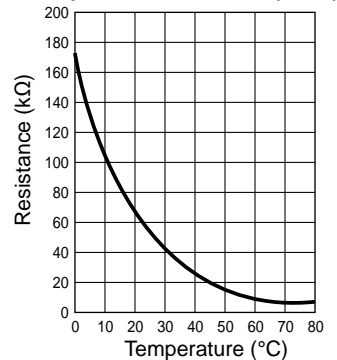

6. Display P.C. board

MXZ-2A30VA MXZ-2A40VA MXZ-2A52VA

To inverter P.C. board (CN936)

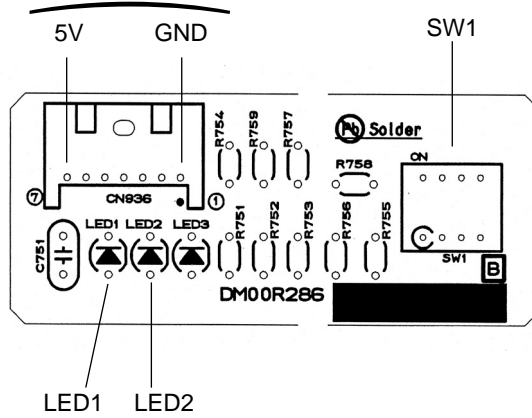

7. Interface P.C. board

MXZ-2A30VA MXZ-2A40VA MXZ-2A52VA

To inverter P.C. board (CN938)

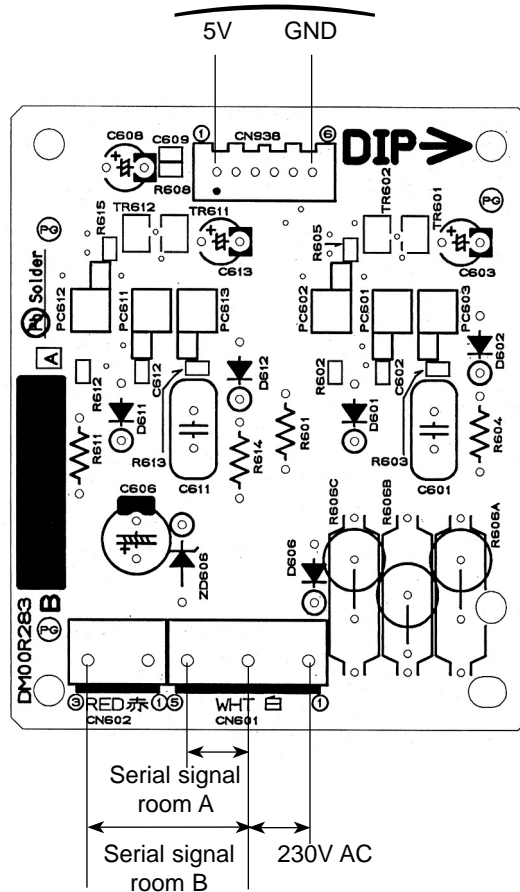

<"Terminal with locking mechanism" Detaching points>

The terminal which has the locking mechanism can be detached as shown below.
There are two types (Refer to (1) and (2)) of the terminal with locking mechanism.
The terminal without locking mechanism can be detached by pulling it out.
Check the shape of the terminal before detaching.

(1) Slide the sleeve and check if there is a locking lever or not.

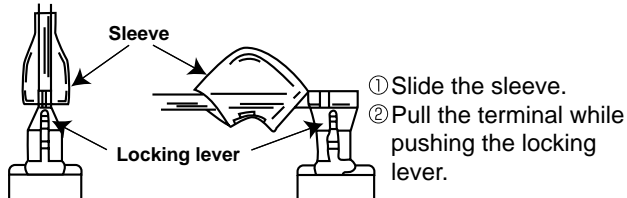

(2) The terminal with this connector has the locking mechanism.

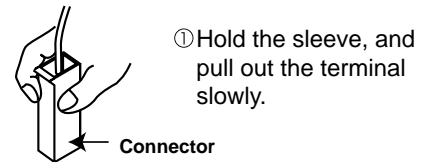

14-1. MXZ-2A30VA MXZ-2A40VA MXZ-2A52VA

NOTE: Turn OFF power supply before disassembly.

OPERATING PROCEDURE	PHOTOS
<p>1. Removing the cabinet</p> <ol style="list-style-type: none"> (1) Remove the screw fixing the service panel. (2) Pull down the service panel and remove it. (3) Disconnect the power supply and indoor/outdoor connecting wire. (4) Remove the screws fixing the top panel. (5) Remove the top panel. (6) Remove the screws fixing the cabinet. (7) Remove the cabinet. (8) Remove the screws fixing the back panel. (9) Remove the back panel. 	<p>Photo 1</p>

OPERATING PROCEDURE

2. Removing the inverter assembly, inverter P.C. board and power P.C. board

- (1) Remove the top panel, cabinet and service panel (Refer to 1).
- (2) Disconnect the power supply and indoor/outdoor connecting wire and remove the back panel (Refer to 1).
- (3) Disconnect the earth wires, the lead wire to the reactor and the following connectors;
<Power P.C. board>
CN912 (R.V coil)
<Inverter P.C. board>
CN931, CN932 (Fan motor)
CN661 (Defrost thermistor, discharge temperature thermistor and outdoor heat exchanger temperature thermistor)
CN663 (Ambient temperature thermistor)
CN791, CN792 (LEV A, LEV B)
- (4) Remove the compressor connector (CN61).
- (5) Remove the screws fixing the relay panel.
- (6) Remove the inverter assembly.
- (7) Disconnect all connectors and lead wires on the inverter P.C. board.
- (8) Remove the inverter P.C. board from the inverter assembly.
- (9) Remove the screw fixing the power P.C. board.
- (10) Disconnect all connectors and lead wires on the power P.C. board.
- (11) Remove the power P.C. board from the inverter assembly.

3. Removing R.V. coil

- (1) Remove the top panel, cabinet and service panel (Refer to 1).
- (2) Disconnect the power supply and indoor/outdoor connecting wire and remove the back panel (Refer to 1).
- (3) Remove the inverter assembly (Refer to 2).
- (4) Remove the R.V. coil.

4. Removing the discharge temperature thermistor, defrost thermistor and outdoor heat exchanger temperature thermistor

- (1) Remove the top panel, cabinet and service panel (Refer to 1).
- (2) Disconnect the power supply and indoor/outdoor connecting wire and remove the back panel (Refer to 1).
- (3) Remove the inverter assembly (Refer to 2).
- (4) Pull out the discharge temperature thermistor from its holder.
- (5) Pull out the defrost thermistor from its holder (Photo 5).
- (6) Pull out the outdoor heat exchanger temperature thermistor from its holder (Photo 5).

PHOTOS

Photo 2

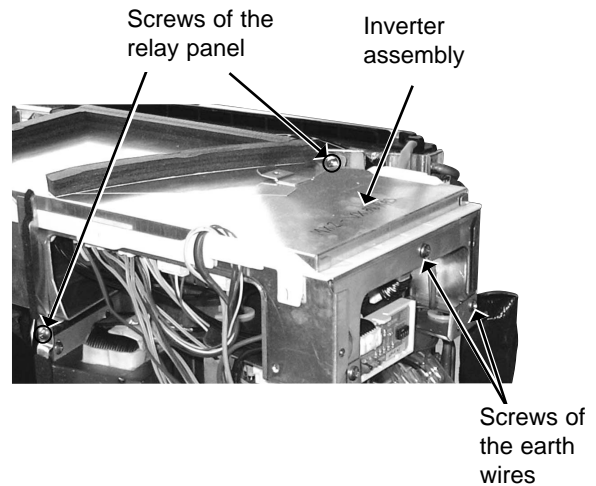

Photo 3

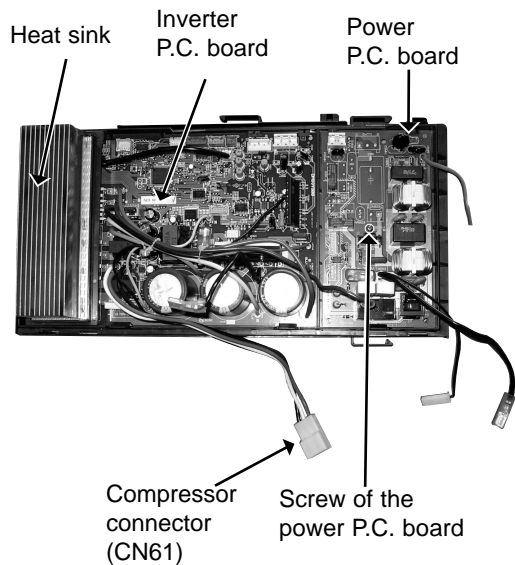
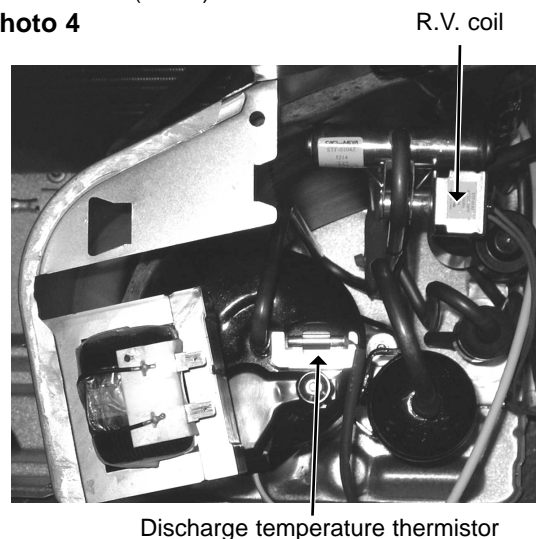

Photo 4



OPERATING PROCEDURE

5. Removing outdoor fan motor

- (1) Remove the top panel, cabinet and service panel (Refer to 1).
- (2) Disconnect the power supply and indoor/outdoor connecting wire.
- (3) Disconnect the connectors for outdoor fan motor.
- (4) Remove the propeller nut.
- (5) Remove the propeller.
- (6) Remove the screws fixing the fan motor (Photo 6).
- (7) Remove the fan motor.

6. Removing the compressor and 4-way valve

- (1) Remove the top panel, cabinet and service panel (Refer to 1).
- (2) Disconnect the power supply and indoor/outdoor connecting wire and remove the back panel (Refer to 1).
- (3) Remove the inverter assembly (Refer to 2).
- (4) Recover gas from the refrigerant circuit.
NOTE: Recover gas from the pipes until the pressure gauge shows 0 kg/cm² (0 MPa).
- (5) Detach the brazed part of the suction and the discharge pipe connected with compressor.
- (6) Remove the nuts of compressor legs.
- (7) Remove the compressor.
- (8) Detach the brazed part of pipes connected with 4-way valve (Photo 7).

PHOTOS

Photo 5

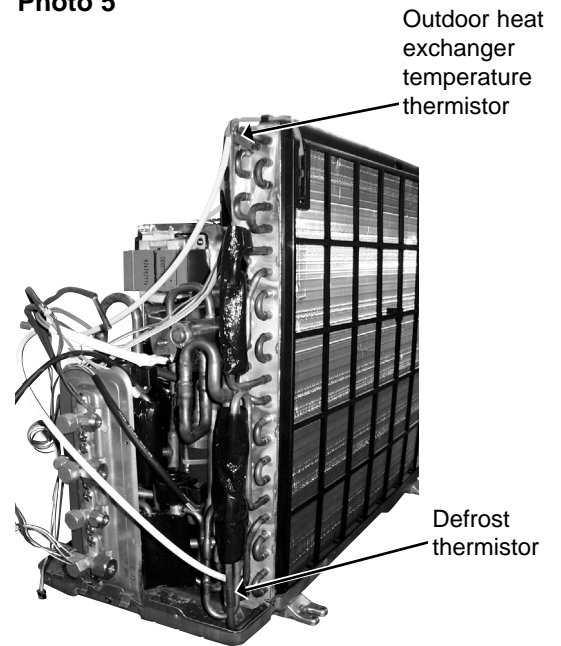

Photo 6

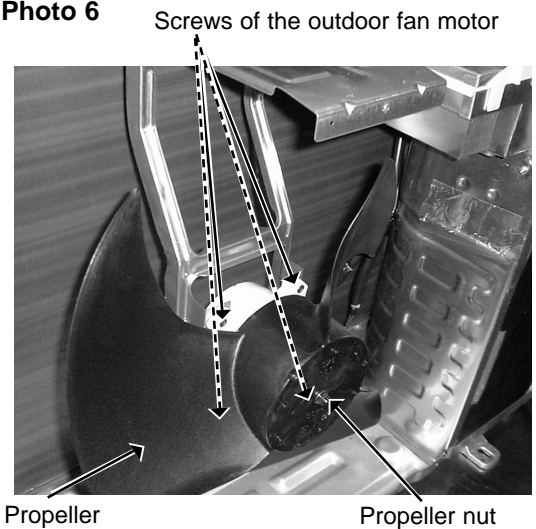
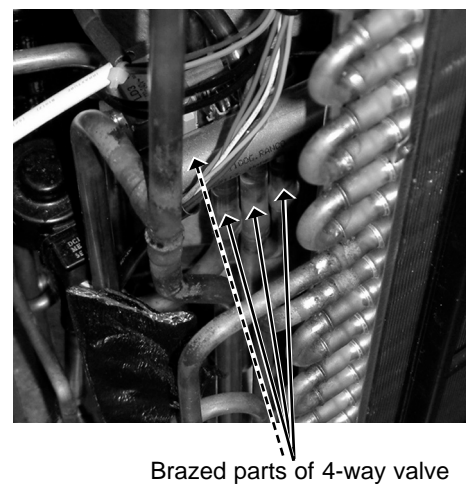
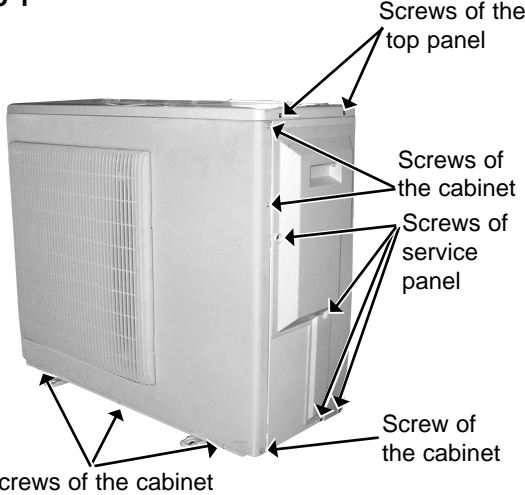
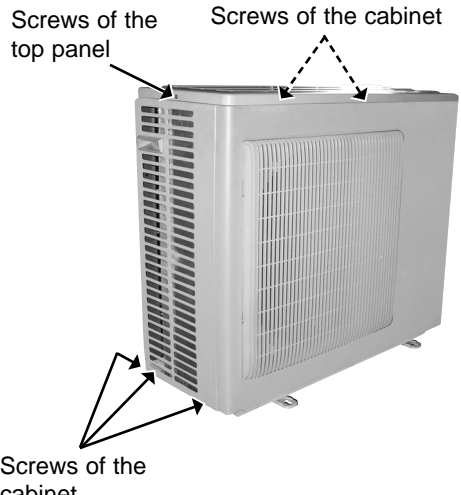

Photo 7



14-2. MXZ-3A54VA - [E1], [E2], [E3], [E4] MXZ-4A71VA - [E1], [E2], [E3], [E4]

NOTE: Turn OFF power supply before disassembly.

OPERATING PROCEDURE	PHOTOS
<p>1. Removing the compressor</p> <p>(1) Remove the screws of the top panel, and remove the top panel.</p> <p>(2) Remove the screws of the service panel, and remove the service panel.</p> <p>(3) Recover gas from the refrigerant circuit.</p> <p>NOTE: Recover gas from the pipes until the pressure gauge shows 0 kg/cm² (0 MPa).</p> <p>(4) Remove the screws of the cabinet, and remove the cabinet.</p> <p>(5) Remove the screws of the back panel, and remove the back panel (Photo 3).</p> <p>(6) Disconnect the compressor lead wire from terminal of the compressor (U, V, W).</p> <p>(7) Disconnect the outdoor electronic control P.C. board connectors: CN661, CN662 (MXZ-3A54/4A71VA-[E1], [E2], [E3]), CN663, CN791, CN792, CN793, CN794 (MXZ-4A71VA-[E1], [E2], [E3], [E4]), CN795, CN931, CN932 Disconnect the noise filter P.C. board connector: CN912</p> <p>(8) Remove the screws of the electrical parts, and remove the electrical parts (Photo 4).</p> <p>(9) Remove the propeller.</p> <p>(10) Remove the screws of the separator, and remove the separator (Photo 6).</p> <p>(11) Remove the sound proof felt (Photo 6).</p> <p>(12) Detach the brazed parts of the compressor suction and discharge pipes (Photo 5).</p> <p>(13) Remove the compressor nuts and remove the compressor.</p>	<p>Photo 1</p>  <p>Photo 2</p> 

OPERATING PROCEDURE

Photo 5

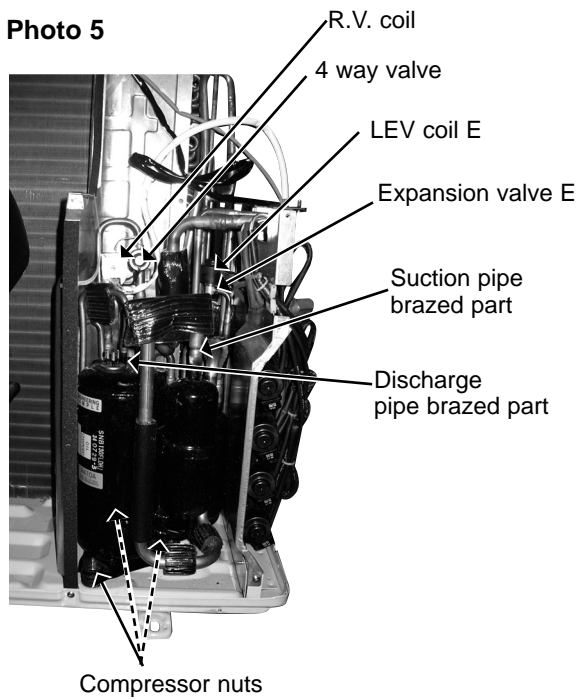

2. Removing the fan motor

- (1) Remove the top panel, the service panel, and the cabinet (Photo 1, 2).
- (2) Disconnect the connector CN931 and CN932 on the outdoor electronic control P.C. board.
- (3) Remove the propeller.
- (4) Remove the fan motor.

PHOTOS

Photo 3

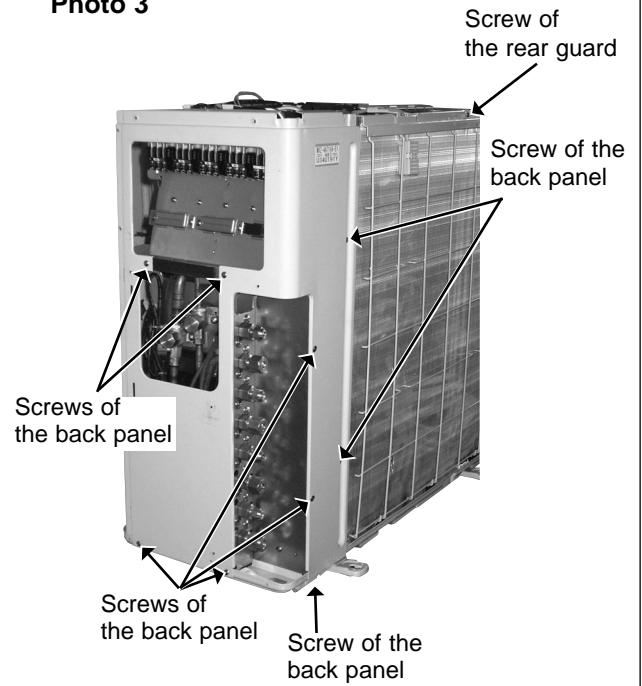

Photo 4

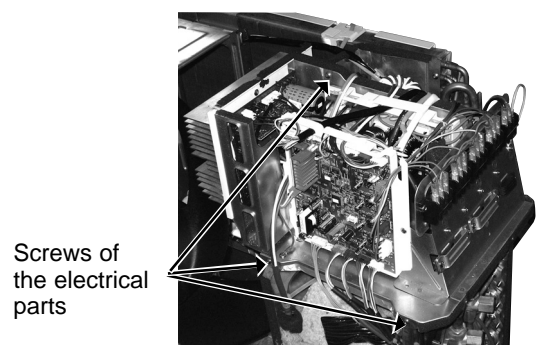
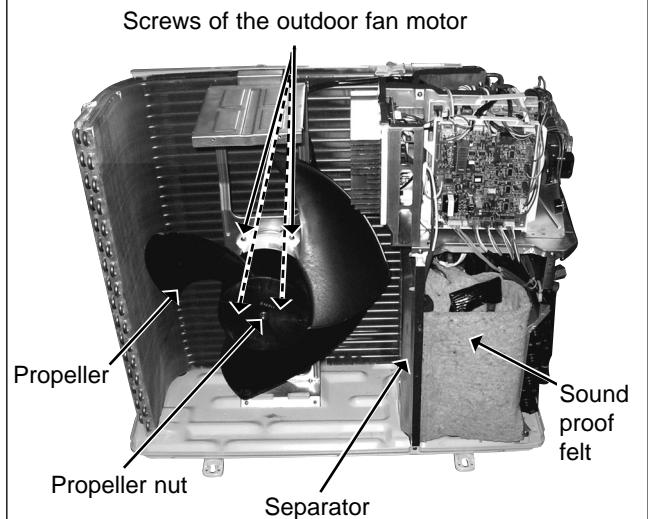

Photo 6





14-3. MXZ-3A54VA - [E5], [E6], [E7] MXZ-4A71VA - [E5], [E6], [E7]

NOTE: Turn OFF power supply before disassembly.

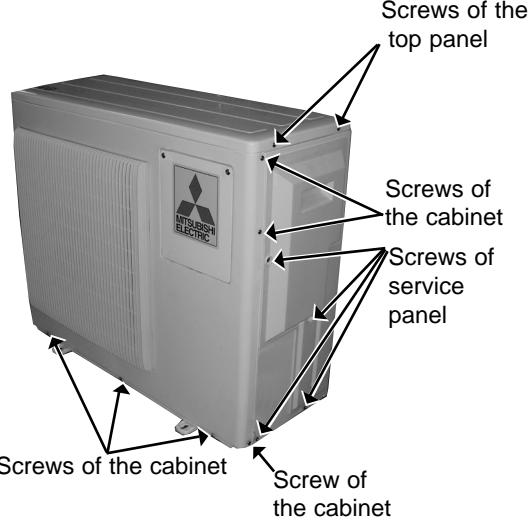
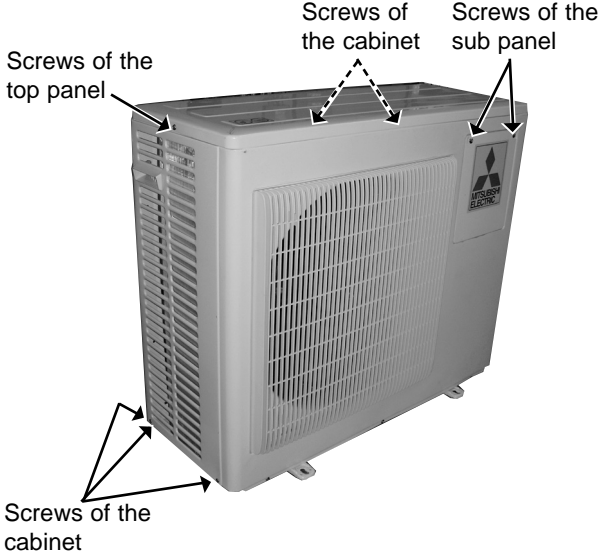
OPERATING PROCEDURE	PHOTOS
<p>1. Removing the compressor</p> <p>(1) Remove the screws of the top panel, and remove the top panel.</p> <p>(2) Remove the screws of the service panel, and remove the service panel.</p> <p>(3) Recover gas from the refrigerant circuit.</p> <p>NOTE: Recover gas from the pipes until the pressure gauge shows 0 kg/cm² (0 MPa).</p> <p>(4) Remove the screws of the cabinet, and remove the cabinet.</p> <p>(5) Remove the screws of the back panel, and remove the back panel (Photo 3).</p> <p>(6) Disconnect the compressor lead wire from terminal of the compressor (U, V, W).</p> <p>(7) Disconnect the outdoor electronic control P.C. board connectors: CN661, CN663, CN791, CN792, CN793, CN794 (MXZ-4A71VA-[E5],[E6],[E7]), CN795, CN931, CN932 Disconnect the noise filter P.C. board connector: CN912</p> <p>(8) Remove the screws of the electrical parts, and remove the electrical parts (Photo 4).</p> <p>(9) Remove the propeller.</p> <p>(10) Remove the screws of the separator, and remove the separator (Photo 6).</p> <p>(11) Remove the sound proof felt (Photo 6).</p> <p>(12) Detach the brazed parts of the compressor suction and discharge pipes (Photo 5).</p> <p>(13) Remove the compressor nuts and remove the compressor.</p>	<p>Photo 1</p>  <p>Photo 2</p> 
<p>2. Removing the electronic control P.C. board</p> <p>(1) Remove the screws of the sub panel.</p> <p>(2) Remove the sub panel.</p> <p>(3) Disconnect all connectors and lead wires on the electronic control P.C. board.</p> <p>(4) Remove the electronic control P.C. board.</p>	

OPERATING PROCEDURE

PHOTOS

Photo 5

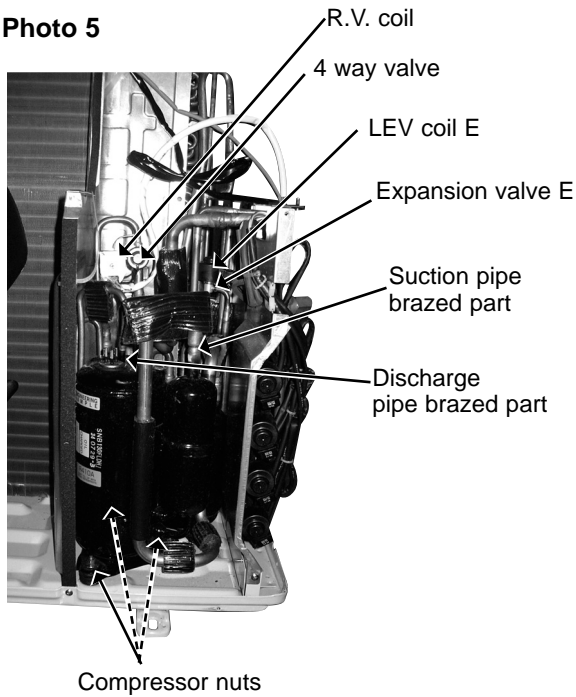

Photo 3

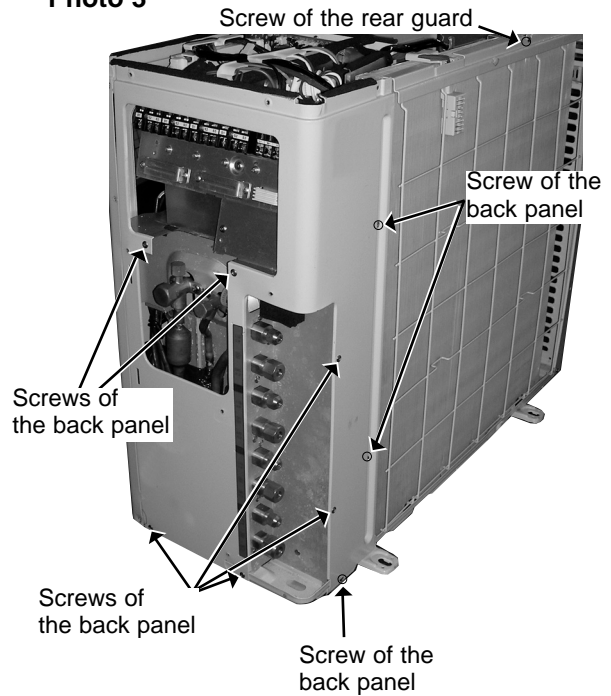
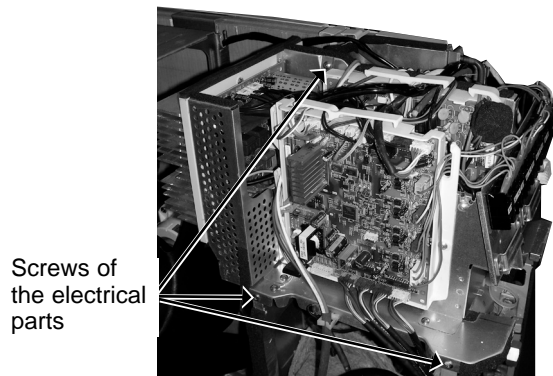

Photo 4



3. Removing the fan motor

- (1) Remove the top panel, the service panel, and the cabinet (Photo 1, 2).
- (2) Disconnect the connector CN931 and CN932 on the outdoor electronic control P.C. board.
- (3) Remove the propeller.
- (4) Remove the fan motor.

Photo 6

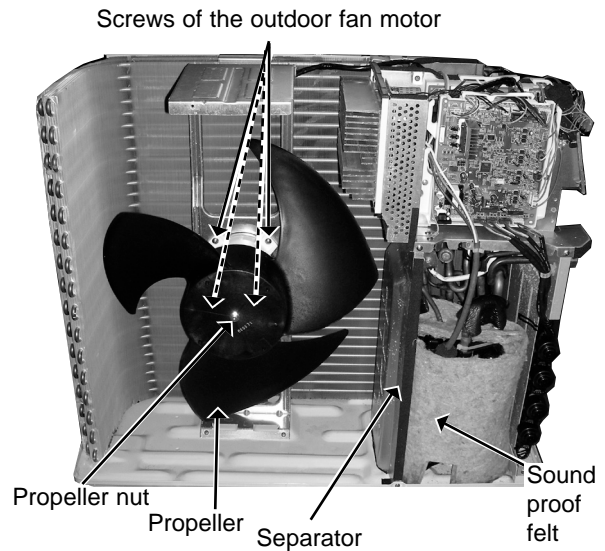

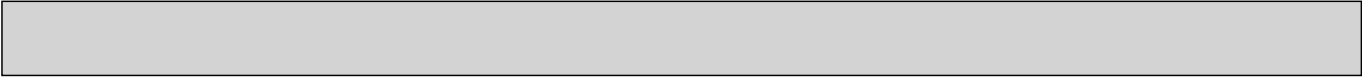

14-4. MXZ-4A80VA - [E1]

NOTE: Turn OFF power supply before disassembly.

OPERATING PROCEDURE

1. Removing the compressor

- (1) Remove the screws of the top panel, and remove the top panel.
 - (2) Remove the screws of the service panel, and remove the service panel.
 - (3) Recover gas from the refrigerant circuit.
- NOTE:** Recover gas from the pipes until the pressure gauge shows 0 kg/cm² (0 MPa).
- (4) Remove the screws of the front panel, and remove the front panel.
 - (5) Disconnect the compressor lead wire from terminal of compressor (U, V, W).
 - (6) Disconnect the outdoor electronic control P.C. board connectors:
CN661, CN662, CN663, CN681, CN791, CN792, CN793, CN794, CN795, CN931, CN932
Disconnect the noise filter P.C. board connector:
CN912
 - (7) Remove the screws of the electrical parts, and remove the electrical parts.
 - (8) Remove the propeller.
 - (9) Remove the screws of the separator, and remove the separator.
 - (10) Remove the sound proof felt.
 - (11) Detach the brazed parts of the compressor suction and discharge pipes (Photo 3).
 - (12) Remove the compressor nuts and remove the compressor.

PHOTOS

Photo 1

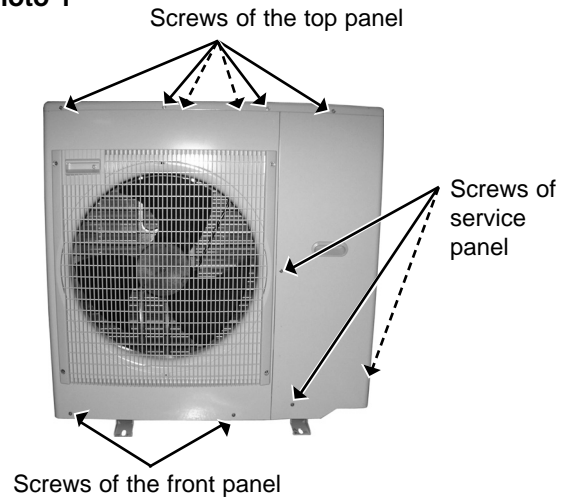

Photo 2

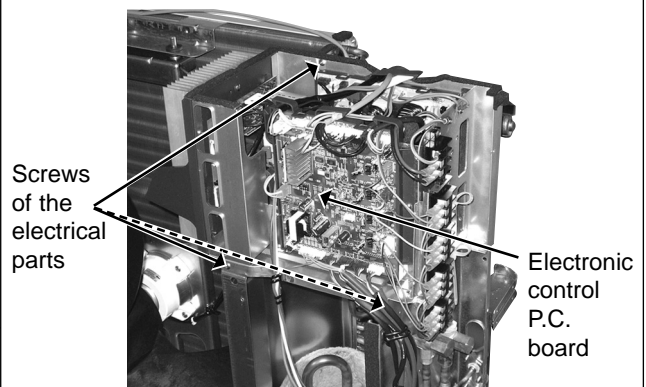
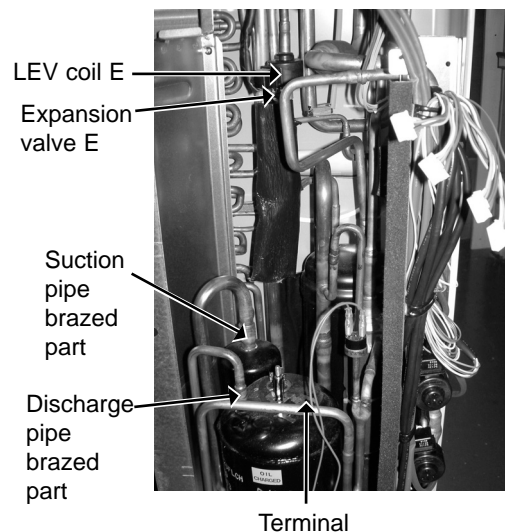
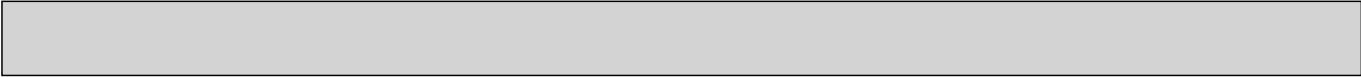

Photo 3





OPERATING PROCEDURE

- 2. Removing the fan motor**
- (1) Remove the top panel, the service panel, and the front panel (Photo 1).
 - (2) Disconnect the connector CN931 and CN932 on the outdoor electronic control P.C. board.
 - (3) Remove the propeller.
 - (4) Remove the fan motor.

PHOTOS

Photo 4

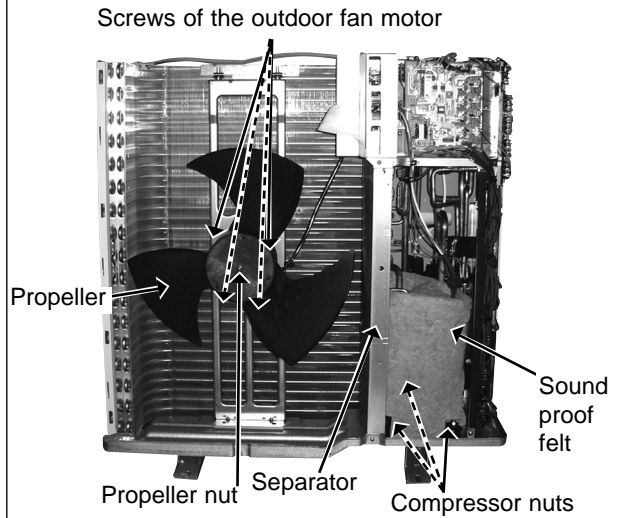

- 3. Removing the 4-way valve**
- (1) Remove the top panel (Photo 1).
 - (2) Remove the service panel, rear panel, and pipe cover.
 - (3) Recover gas from the refrigerant circuit.
- NOTE:** Recover gas from the pipes until the pressure gauge shows 0 kg/cm² (0 MPa).
- (4) Remove the electrical parts (Photo 2).
 - (5) Detach the brazed parts of 4-way valve and pipe (Photo 5).

Photo 5

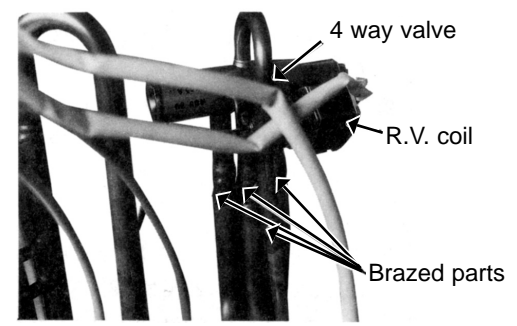

- 4. Removing the expansion valve**
- (1) Remove the top panel (Photo 1).
 - (2) Remove the service panel (Photo 1).
(Gas recovery is not required if the unit is pumped down.)
 - (3) Remove the front panel for removing LEV E (Photo 1).
 - (4) Remove the electrical parts for removing LEV E (Photo 2,3).
 - (5) Remove the LEV coils.
 - (6) Detach the brazed parts of expansion valves and pipes.

Photo 6

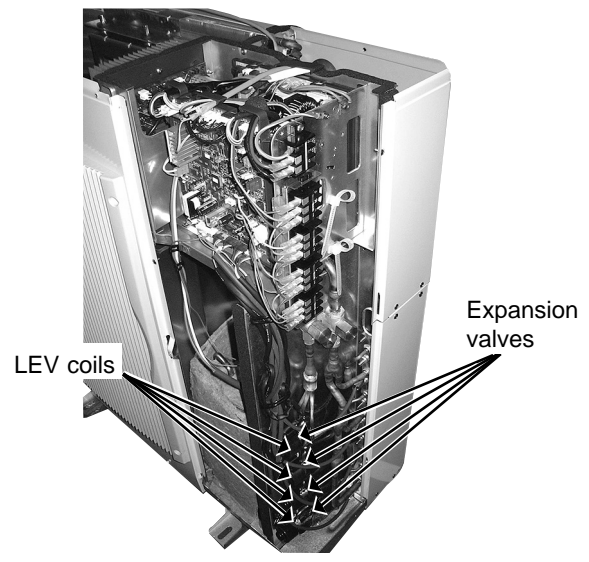

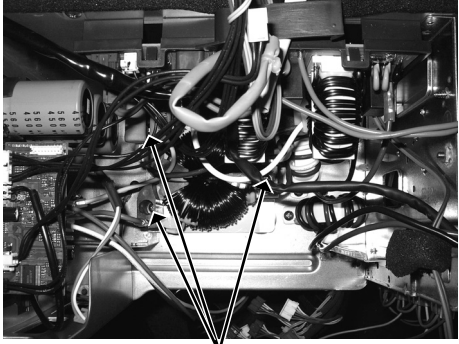

OPERATING PROCEDURE	PHOTOS
<p>5. Removing the reactor</p> <ul style="list-style-type: none">(1) Remove the top panel (Photo 1).(2) Disconnect the reactor lead wire.(3) Remove the screws of the reactor, and remove the reactor.	<p>Photo 7</p>  <p>Screws of the reactor</p>

14-5. MXZ-4A80VA - MXZ-5A100VA

NOTE: Turn OFF power supply before disassembly.

OPERATING PROCEDURE

1. Removing the compressor

- (1) Remove the screws of the top panel, and remove the top panel.
- (2) Remove the screws of the service panel, and remove the service panel.
- (3) Recover gas from the refrigerant circuit.

NOTE: Recover gas from the pipes until the pressure gauge shows 0 kg/cm² (0 MPa).

- (4) Remove the screws of the front panel, and remove the front panel.
- (5) Remove the screws of the rear panel, and remove the rear panel.
- (6) Disconnect the compressor lead wire from terminal of compressor (U, V, W).
- (7) Disconnect the outdoor electronic control P.C. board connectors:
CN661, CN663, CN681, CN791, CN792, CN793, CN794, CN795 (MXZ-5A100VA), CN796, CN931, CN932
Disconnect the noise filter P.C. board connector:
CN912
- (8) Remove the screws of the electrical parts, and remove the electrical parts.
- (9) Remove the propeller.
- (10) Remove the screws of the separator, and remove the separator.
- (11) Remove the sound proof felt.
- (12) Detach the brazed parts of the compressor suction and discharge pipes (Photo 4).
- (13) Remove the compressor nuts and remove the compressor.

Photo 3

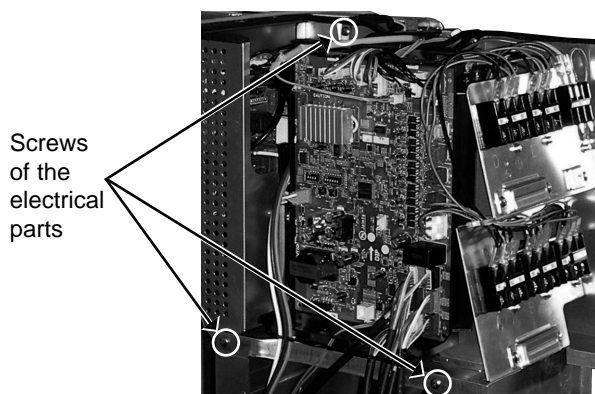

PHOTOS

Photo 1

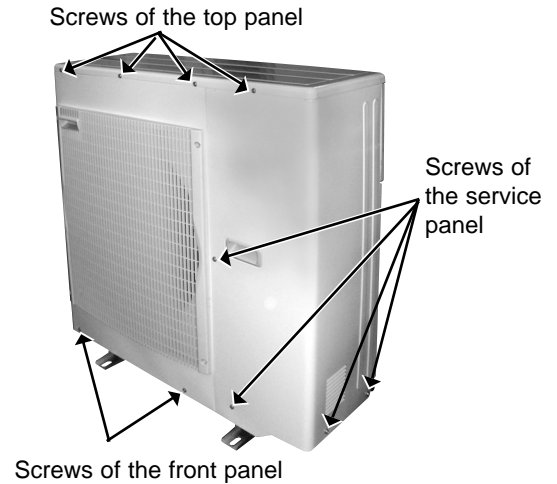

Photo 2

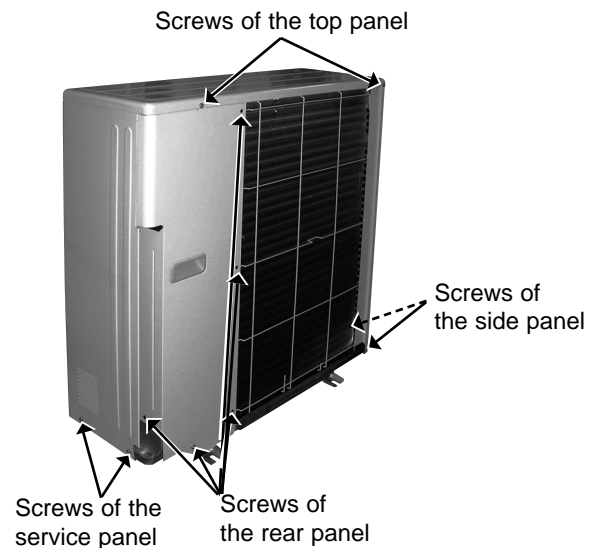
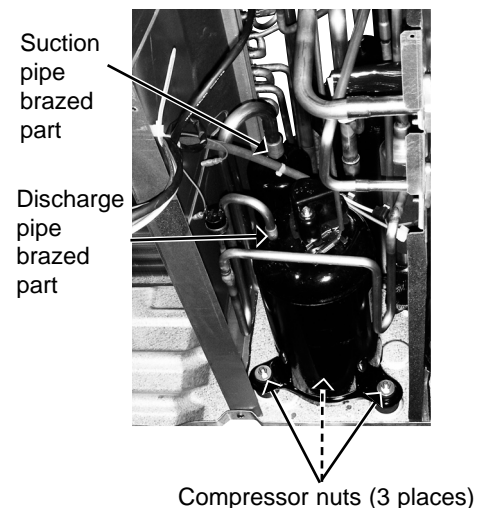

Photo 4



OPERATING PROCEDURE

2. Removing the fan motor

- (1) Remove the top panel, the service panel, and the front panel (Photo 1).
- (2) Disconnect the connector CN931 and CN932 on the outdoor electronic control P.C. board.
- (3) Remove the propeller.
- (4) Remove the fan motor.

PHOTOS

Photo 5 Screws of the outdoor fan motor

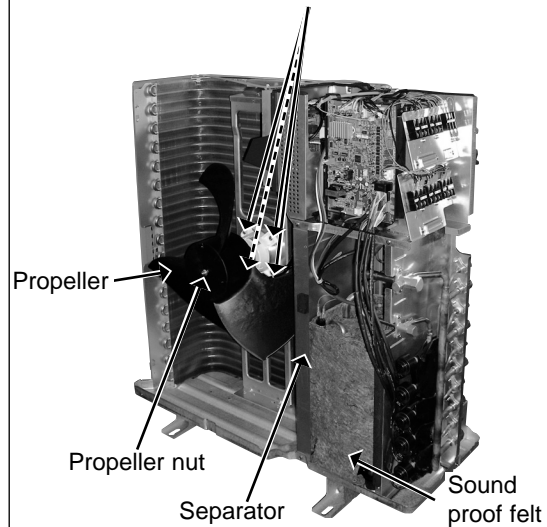

3. Removing the 4-way valve

- (1) Remove the top panel (Photo 1).
- (2) Remove the service panel, rear panel, and pipe cover.
- (3) Recover gas from the refrigerant circuit.
NOTE: Recover gas from the pipes until the pressure gauge shows 0 kg/cm² (0 MPa).
- (4) Remove the electrical parts (Photo 3).
- (5) Detach the brazed parts of 4-way valve and pipe.

Photo 6

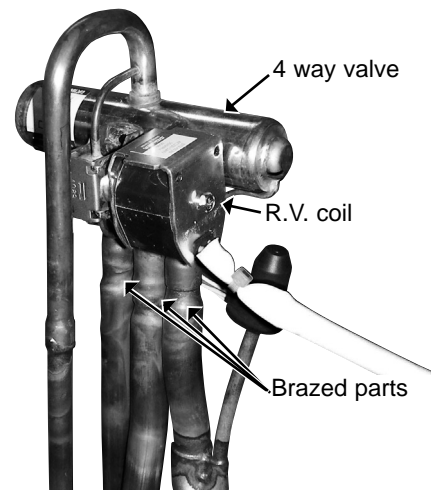

4. Removing the expansion valve

- (1) Remove the top panel (Photo 1,2).
- (2) Remove the service panel (Photo 1).
(Gas recovery is not required if the unit is pumped down.)
- (3) Remove the front panel for removing LEV F (Photo 1).
- (4) Remove the electrical parts for removing LEV F (Photo 3).
- (5) Remove the LEV coils.
- (6) Detach the brazed parts of expansion valves and pipes.

Photo 7

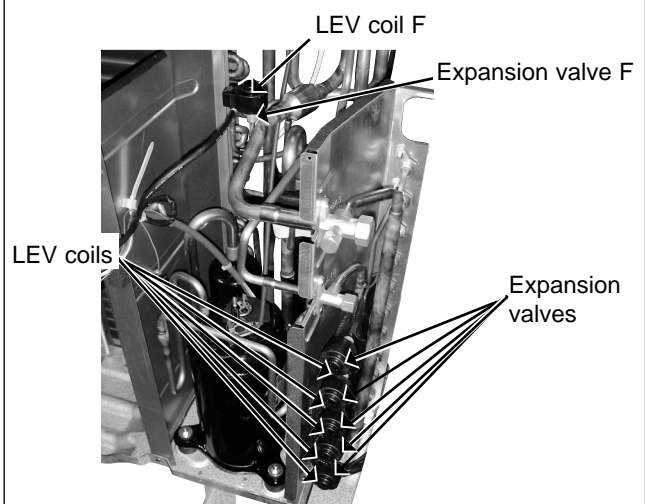



OPERATING PROCEDURE

5. Removing the reactor

- (1) Remove the top panel (Photo 1).
- (2) Disconnect the reactor lead wire.
- (3) Remove the screws of the reactor, and remove the reactor.

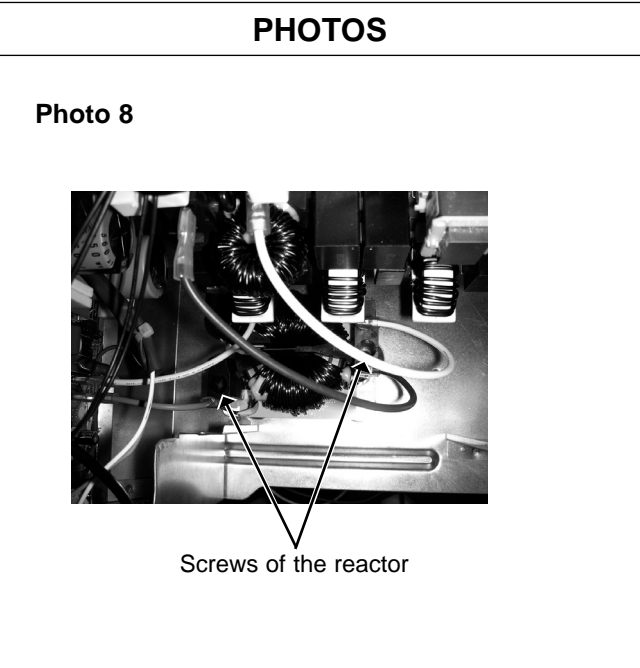

MXZ-2A40VA - E1 MXZ-2A52VA - E1

15-1. OUTDOOR UNIT STRUCTURAL PARTS AND FUNCTIONAL PARTS

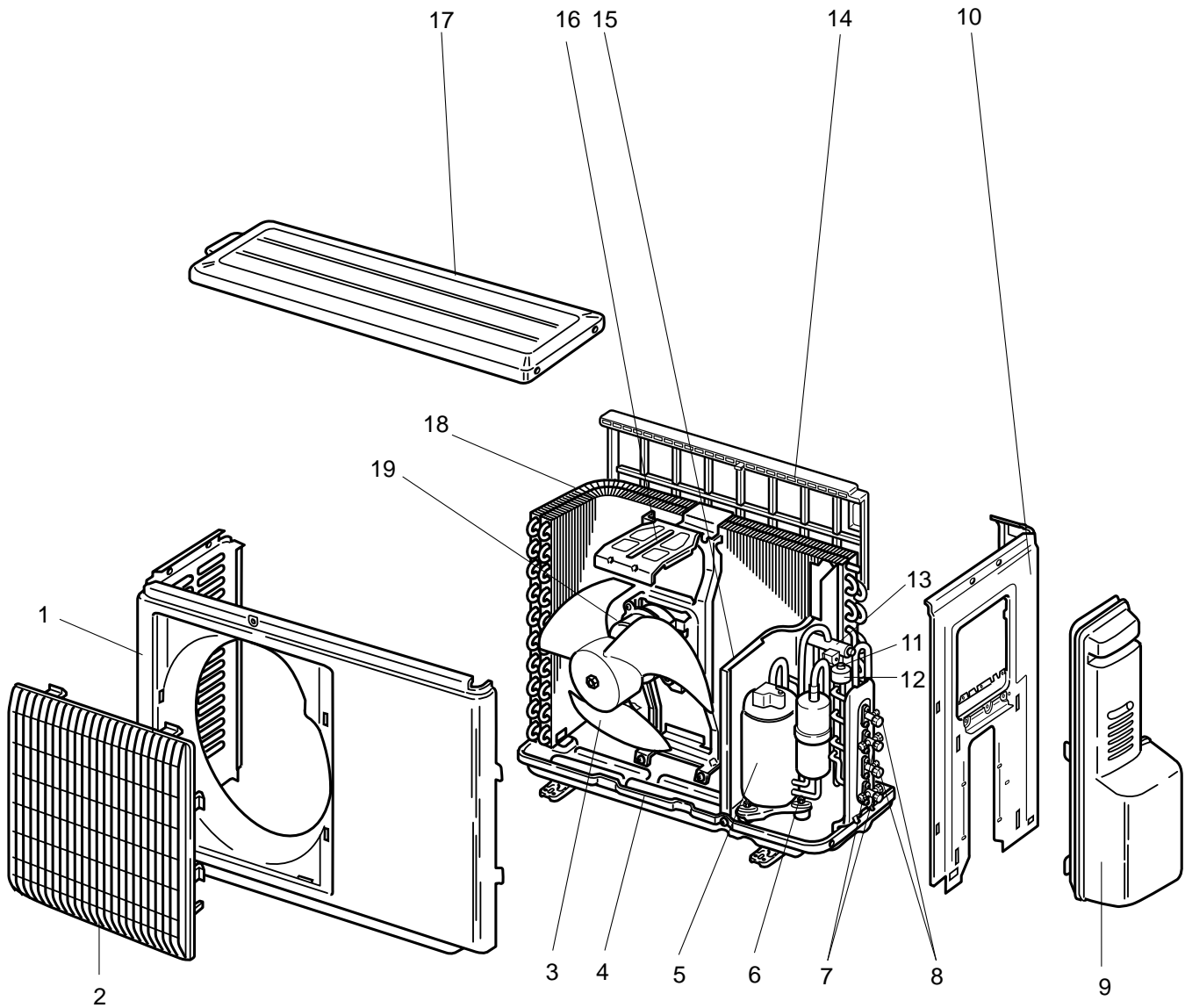

PARTS LIST (non-RoHS compliant)

MXZ-2A40VA - E1 MXZ-2A52VA - E1

15-1. OUTDOOR UNIT STRUCTURAL PARTS AND FUNCTIONAL PARTS

Part numbers that are circled are not shown in the illustration.

No.	Part No.	Part Name	Symbol in Wiring Diagram	Q'ty/unit		Remarks
				MXZ-2A40VA- E1	MXZ-2A52VA- E1	
1	E02 927 232	CABINET		1	1	
2	E02 927 521	GRILLE		1	1	
3	E02 927 501	PROPELLER		1	1	
4	E02 A45 290	BASE		1	1	
5	E02 A47 900	COMPRESSOR	MC	1	1	SNB130FKCH
6	E02 065 506	COMPRESSOR RUBBER SET		3	3	3RUBBERS/SET
7	E02 927 661	STOP VALVE (GAS)		2	2	φ 9.52
8	E02 927 662	STOP VALVE (LIQUID)		2	2	φ 6.35
9	E02 A47 245	SERVICE PANEL		1	1	
10	E02 A47 233	BACK PANEL		1	1	
11	E02 735 640	EXPANSION VALVE		1	1	ROOM B
12	E02 A48 493	EXPANSION VALVE COIL	LEV B	1	1	
13	E02 A47 961	4-WAY VALVE		1	1	
14	E02 929 523	CONDENSER NET		1	1	
15	E02 929 293	SEPARATOR		1	1	
16	E02 929 515	MOTOR SUPPORT		1	1	
17	E02 927 297	TOP PANEL		1	1	
18	E02 A47 630	OUTDOOR HEAT EXCHANGER		1	1	
19	E02 A47 301	OUTDOOR FAN MOTOR	MF	1	1	RC0J50-□□
⑳	E02 339 936	CAPILLARY TUBE		4	4	φ3.0×φ1.4×600
	E02 838 936	CAPILLARY TUBE		2	2	φ3.0×φ2.0×200
㉑	E02 735 640	EXPANSION VALVE		1	1	ROOM A
㉒	E02 A47 493	EXPANSION VALVE COIL	LEV A	1	1	

PARTS LIST (non-RoHS compliant)

MXZ-2A40VA - E1 MXZ-2A52VA - E1

15-2. OUTDOOR UNIT ELECTRICAL PARTS

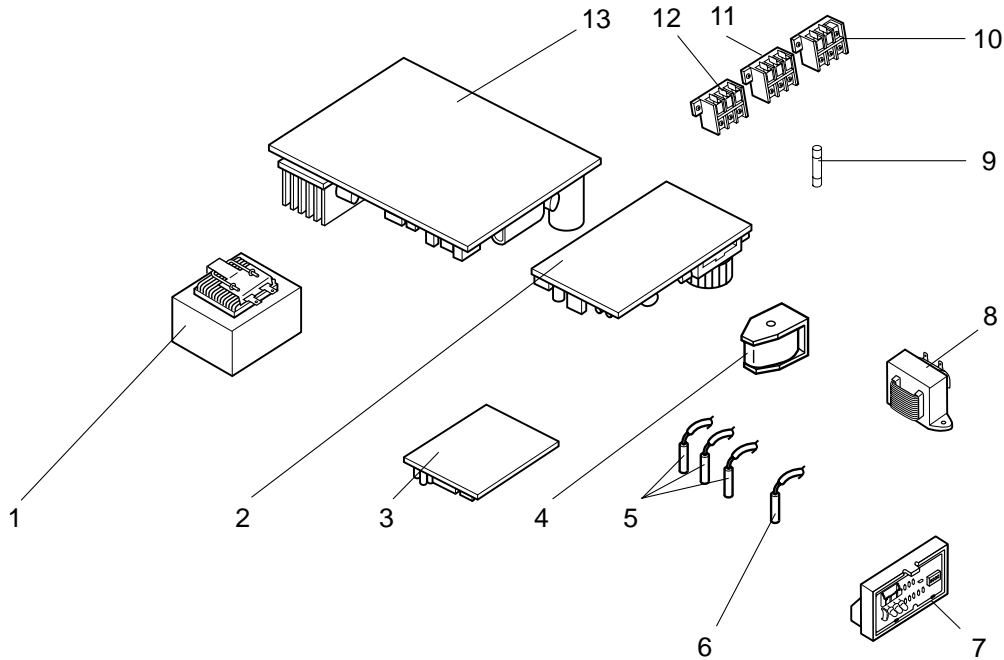

Part numbers that are circled are not shown in the illustration.

No.	Part No.	Part Name	Symbol in Wiring Diagram	Q'ty/unit		Remarks
				MXZ-2A40VA- E1	MXZ-2A52VA- E1	
1	E02 838 337	REACTOR	L64	1	1	10A 23mH
2	E02 A47 440	POWER P.C. BOARD		1	1	
3	E02 A47 454	INTERFACE P.C. BOARD		1	1	
4	E02 A47 490	R.V. COIL	21S4	1	1	
5	E02 A47 308	THERMISTOR SET	RT61,62,68	1	1	DEFROST, DISCHARGE OUTDOOR HEAT EXCHANGER
6	E02 A47 309	AMBIENT TEMPERATURE THERMISTOR	RT65	1	1	
7	E02 A47 329	DISPLAY P.C. BOARD		1	1	
8	E02 A47 337	REACTOR	L65	1	1	2A 25mH
9	E02 735 382	FUSE	F61	1	1	T20AL250V
10	E02 A47 374	TERMINAL BLOCK	TB1	1	1	Power supply
11	E02 935 374	TERMINAL BLOCK	TB3	1	1	Indoor unit connecting
12	E02 935 374	TERMINAL BLOCK	TB2	1	1	Indoor unit connecting
13	E02 A47 451	INVERTER P.C. BOARD		1		Including heat sink and RT64
	E02 A48 451	INVERTER P.C. BOARD			1	Including heat sink and RT64

PARTS LIST (non-RoHS compliant)

MXZ-2A40VA - E1 MXZ-2A52VA - E1

15-3. DRAIN SOCKET

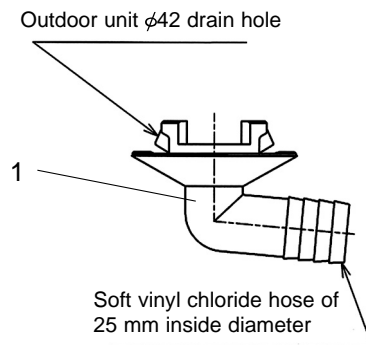

No.	Parts No.	Parts Name	Symbol in Wiring Diagram	Q'ty/unit		Remarks
				MXZ-2A40VA- E1	MXZ-2A52VA- E1	
1	E02 838 704	DRAIN SOCKET		1	1	

PARTS LIST (non-RoHS compliant)

MXZ-3A54VA - E1, E2

MXZ-4A71VA - E1, E2

15-4. OUTDOOR UNIT STRUCTURAL PARTS AND FUNCTIONAL PARTS

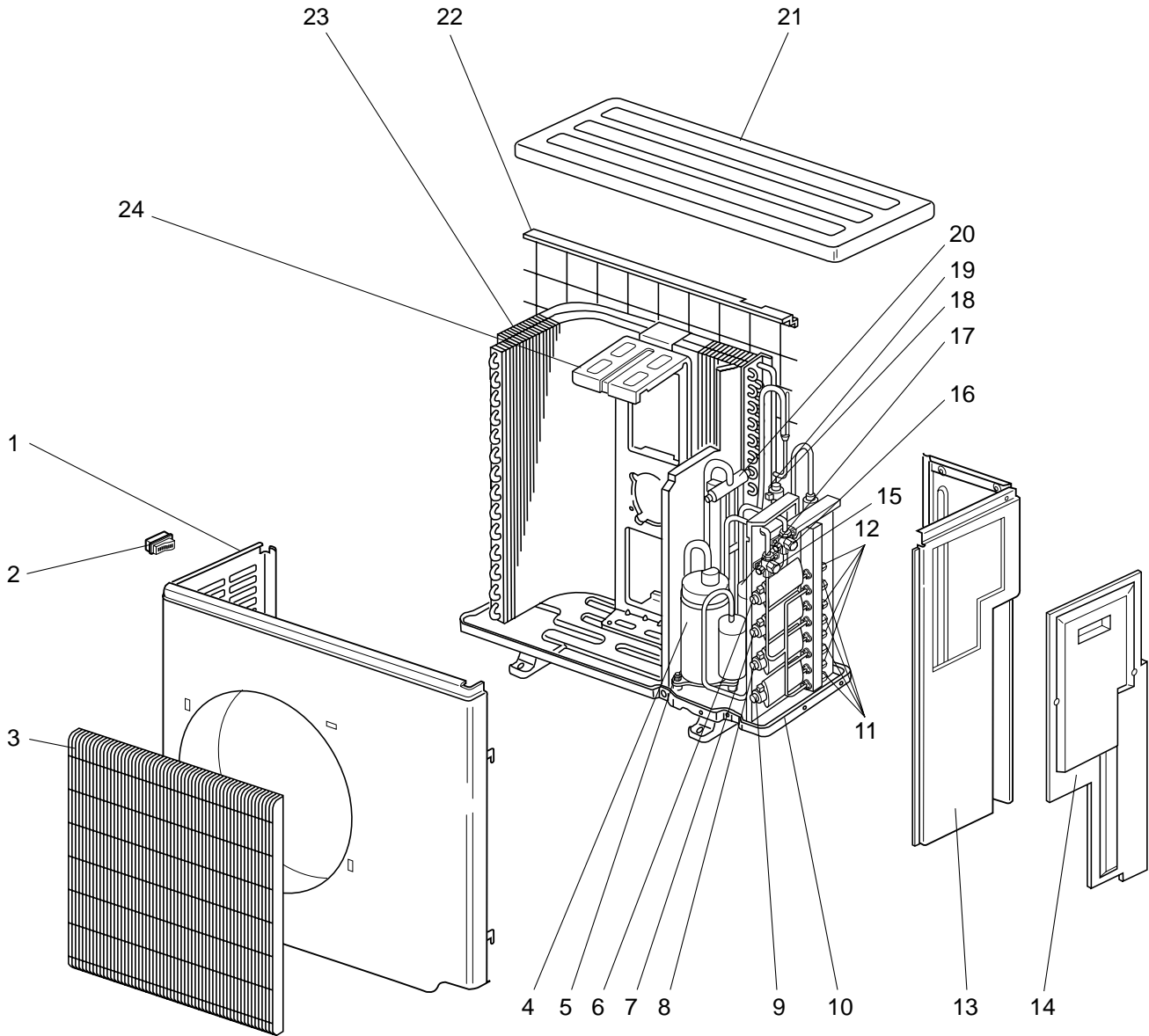

PARTS LIST (non-RoHS compliant)

MXZ-3A54VA - E1, E2

MXZ-4A71VA - E1, E2

15-4. OUTDOOR UNIT STRUCTURAL PARTS AND FUNCTIONAL PARTS

Part numbers that are circled are not shown in the illustration.

No.	Parts No.	Parts Name	Symbol in Wiring Diagram	Q'ty/unit				Remarks
				MXZ-3A54VA-		MXZ-4A71VA-		
				E1	E2	E1	E2	
1	E02 939 232	CABINET		1	1	1	1	
2	E02 817 009	HANDLE		1	1	1	1	
3	E02 939 521	GRILLE		1	1	1	1	
4	E02 939 900	COMPRESSOR	MC	1	1	1	1	SNB130FLDH1
5	E02 065 506	COMPRESSOR RUBBER SET		3	3	3	3	3RUBBERS SET
6	E02 851 640	EXPANSION VALVE				1	1	D room
	E02 939 494	LEV COIL	LEV D			1	1	D room
7	E02 851 640	EXPANSION VALVE		1	1	1	1	C room
	E02 938 494	LEV COIL	LEV C	1	1	1	1	C room
8	E02 851 640	EXPANSION VALVE		1	1	1	1	B room
	E02 939 493	LEV COIL	LEV B	1	1	1	1	B room
9	E02 851 640	EXPANSION VALVE		1	1	1	1	A room
	E02 938 493	LEV COIL	LEV A	1	1	1	1	A room
10	E02 939 290	BASE		1	1	1	1	
11	E02 939 666	UNION(GAS)		3	3	3	3	φ 9.52
	E02 979 666	UNION(GAS)				1	1	φ 12.7
12	E02 939 667	UNION(LIQUID)		3	3	4	4	φ 6.35
13	E02 939 233	BACK PANEL		1	1	1	1	
14	E02 939 245	SERVICE PANEL		1	1	1	1	
15	E02 939 661	BALL VALVE (GAS) 5/8		1	1	1	1	φ 15.88
16	E02 939 662	BALL VALVE (LIQUID) 3/8		1	1	1	1	φ 9.52
17	E02 938 959	POWER RECEIVER		1	1	1	1	
18	E02 853 640	EXPANSION VALVE		1	1	1	1	E
19	E02 851 493	LEV COIL	LEV E	1	1	1	1	
20	E02 891 961	4-WAY VALVE		1	1	1	1	
21	E02 819 297	TOP PANEL		1	1	1	1	
22	E02 939 523	REAR GUARD		1	1	1	1	
23	E02 939 630	OUTDOOR HEAT EXCHANGER		1	1	1	1	
24	E02 939 515	MOTOR SUPPORT		1	1	1	1	
25	E02 938 937	CAPILLARY TUBE		8	8	8	8	φ3.6×φ2.4×500
26	E02 939 936	CAPILLARY TUBE		3	3	4	4	φ4.0×φ2.8×100
27	E02 938 936	CAPILLARY TUBE		1	1	1	1	φ2.5×φ0.6×1000
28	E02 938 299	OIL SEPARATOR		1	1	1	1	

PARTS LIST (non-RoHS compliant)

MXZ-3A54VA - E1, E2

MXZ-4A71VA - E1, E2

15-5. OUTDOOR UNIT FUNCTIONAL PARTS AND ELECTRICAL PARTS

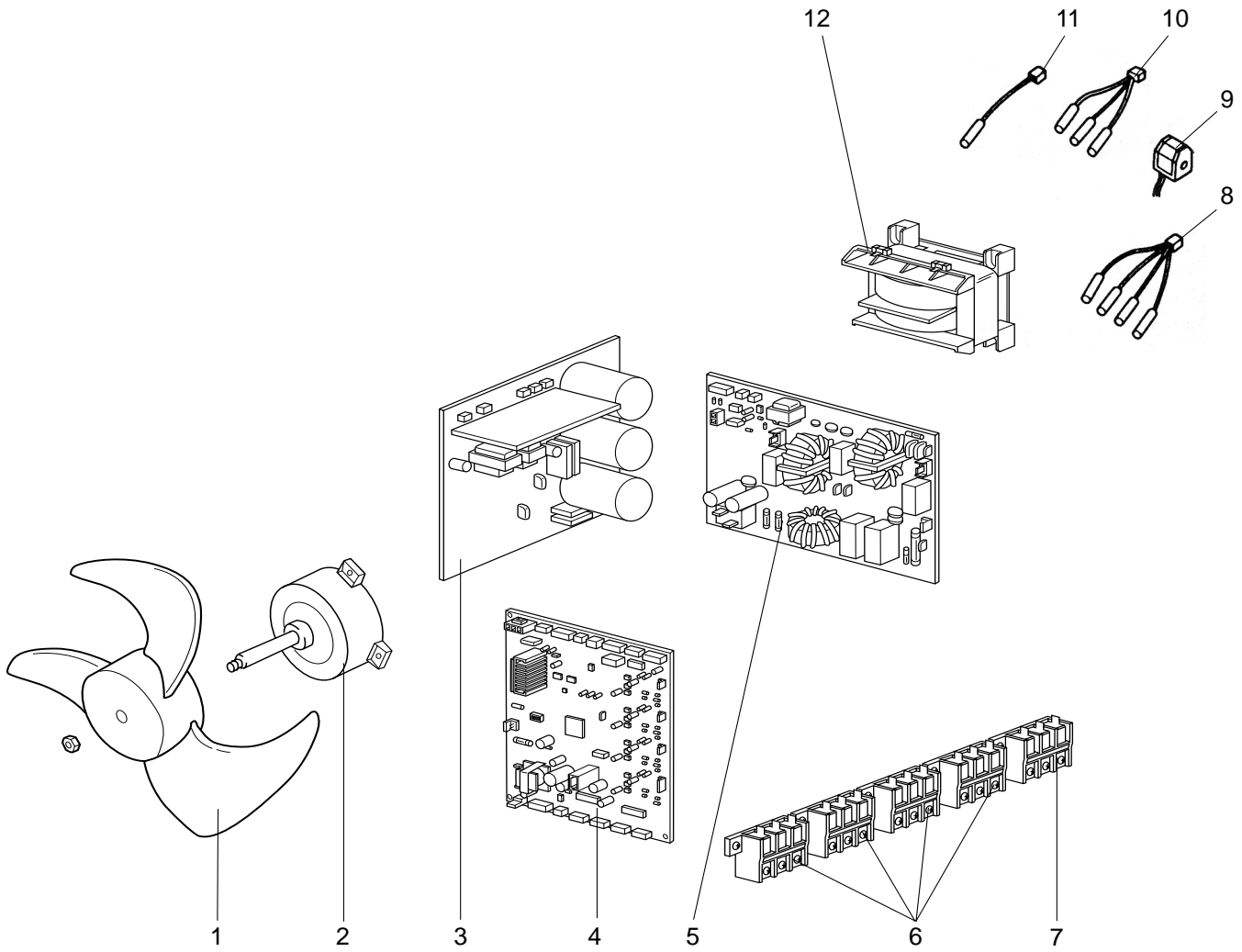

15-6. ACCESSORY

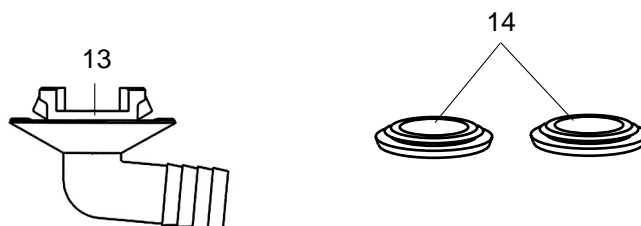

PARTS LIST (non-RoHS compliant)

MXZ-3A54VA - E1, E2

MXZ-4A71VA - E1, E2

15-5. OUTDOOR UNIT FUNCTIONAL PARTS AND ELECTRICAL PARTS

Part numbers that are circled are not shown in the illustration.

No.	Parts No.	Parts Name	Symbol in Wiring Diagram	Q'ty/unit				Remarks
				MXZ-3A54VA-		MXZ-4A71VA-		
				E1	E2	E1	E2	
1	E02 851 501	PROPELLER		1	1	1	1	
2	E02 938 301	OUTDOOR FAN MOTOR	MF	1	1	1	1	RC0J60- □□
3	E02 939 440	POWER BOARD		1	1	1	1	Including heat sink and RT64
4	E02 938 450	ELECTRONIC CONTROL P.C. BOARD		1	1			
	E02 939 450	ELECTRONIC CONTROL P.C. BOARD				1	1	
5	E02 938 444	NOISE FILTER P.C. BOARD		1	1	1	1	
6	E02 927 374	TERMINAL BLOCK	TB2~5	3	3	4	4	Indoor unit connecting
7	E02 823 375	TERMINAL BLOCK	TB1	1	1	1	1	Power supply
8	E02 938 307	GAS PIPE TEMPERATURE THERMISTOR SET	RT6A,B,C	1	1			
	E02 939 307	GAS PIPE TEMPERATURE THERMISTOR SET	RT6A,B,C,D			1	1	
9	E02 939 490	R.V. COIL	21S4	1	1	1	1	
10	E02 938 308	THERMISTOR SET	RT61,62,68	1	1	1	1	DEFROST DISCHARGE OUTDOOR HEAT EXCHANGER
11	E02 938 309	AMBIENT TEMPERATURE THERMISTOR	RT65	1	1	1	1	
12	E02 938 337	REACTOR	L	1	1	1	1	20A 600μH

15-6. ACCESSORY

No.	Parts No.	Parts Name	Symbol in Wiring Diagram	Q'ty/unit				Remarks
				MXZ-3A54VA-		MXZ-4A71VA-		
				E1	E2	E1	E2	
13	E02 817 704	DRAIN SOCKET		1	1	1	1	
14	E02 444 705	DRAIN CAP		2	2	2	2	

PARTS LIST (non-RoHS compliant)

MXZ-4A80VA - E1

15-7. OUTDOOR UNIT STRUCTURAL PARTS AND FUNCTIONAL PARTS

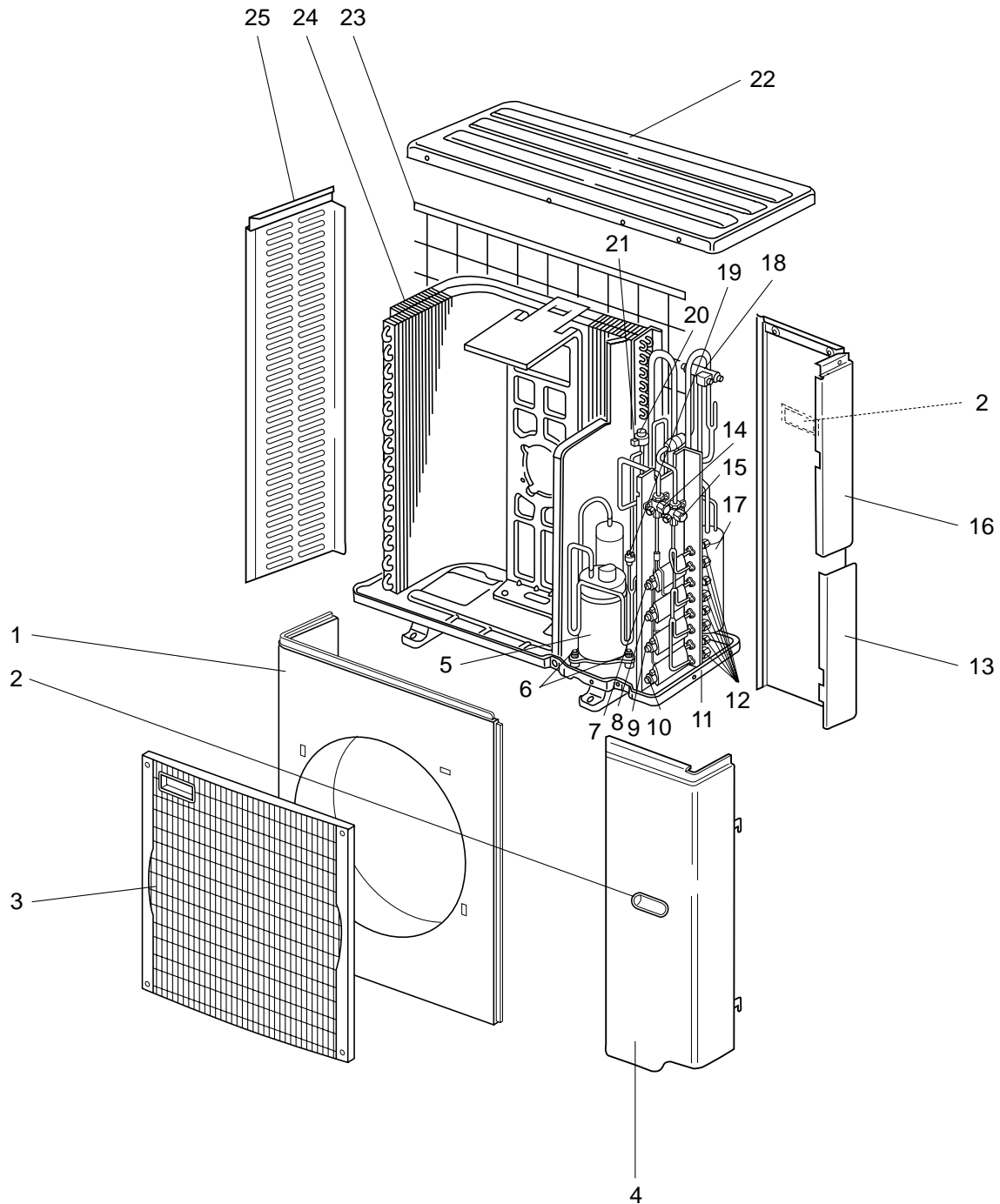

PARTS LIST (non-RoHS compliant)

MXZ-4A80VA - E1

15-7. OUTDOOR UNIT STRUCTURAL PARTS AND FUNCTIONAL PARTS

Part numbers that are circled are not shown in the illustration.

No.	Parts No.	Parts Name	Symbol in Wiring Diagram	Q'ty/unit	Remarks
				MXZ-4A80VA- E1	
1	M21 TK0 232	FRONT PANEL		1	
2	M21 TK0 027	HANDLE ASSEMBLY		2	
3	M21 TK5 010	GRILLE		1	
4	M21 TK0 245	SERVICE PANEL		1	
5	T92 500 801	COMPRESSOR	MC	1	TNB220FMCH
6	T2W TK0 505	COMPRESSOR RUBBER SET		3	3RUBBERS SET
7	R01 E39 401	EXPANSION VALVE		1	D room
	T2W TK0 654	LEV COIL	LEV D	1	D room
8	R01 E39 401	EXPANSION VALVE		1	C room
	T2W TK0 653	LEV COIL	LEV C	1	C room
9	R01 E39 401	EXPANSION VALVE		1	B room
	T2W TK0 652	LEV COIL	LEV B	1	B room
10	R01 E39 401	EXPANSION VALVE		1	A room
	T2W TK0 651	LEV COIL	LEV A	1	A room
11	M21 TK0 290	BASE ASSEMBLY		1	
12	M21 42E 644	UNION		1	$\phi 12.7, \phi 9.52, \phi 6.35$ SET
13	T2W TK0 247	PIPE COVER		1	
14	M21 TK5 667	BALL VALVE (LIQUID) 3/8		1	$\phi 9.52$
15	M21 TK0 667	BALL VALVE (GAS) 5/8		1	$\phi 15.88$
16	M21 TK0 248	REAR PANEL		1	
17	T2W TK0 959	POWER RECEIVER		1	
18	M21 G0H 642	4-WAY VALVE		1	
19	M21 NT1 646	HIGH PRESSURE SWITCH	HPS	1	4.8 MPa (48.9 kg/cm ²)
20	T2W WW8 401	EXPANSION VALVE		1	E
21	T2W TK0 651	LEV COIL	LEV E	1	
22	M21 TK0 297	TOP PANEL		1	
23	T2W E40 523	REAR GUARD		1	
24	M21 YH1 630	OUTDOOR HEAT EXCHANGER		1	
25	M21 TK0 249	SIDE PANEL		1	
②6	M21 SJ4 937	CAPILLARY TUBE		2	$\phi 4.0 \times \phi 2.4 \times 400$
②7	M21 TK0 936	CAPILLARY TUBE		4	$\phi 4.0 \times \phi 2.8 \times 90$
②8	T2W E59 936	CAPILLARY TUBE		1	$\phi 2.5 \times \phi 0.6 \times 1000$
②9	T2W YH1 656	OIL SEPARATOR		1	

PARTS LIST (non-RoHS compliant)

MXZ-4A80VA - E1

15-8. OUTDOOR UNIT FUNCTIONAL PARTS AND ELECTRICAL PARTS

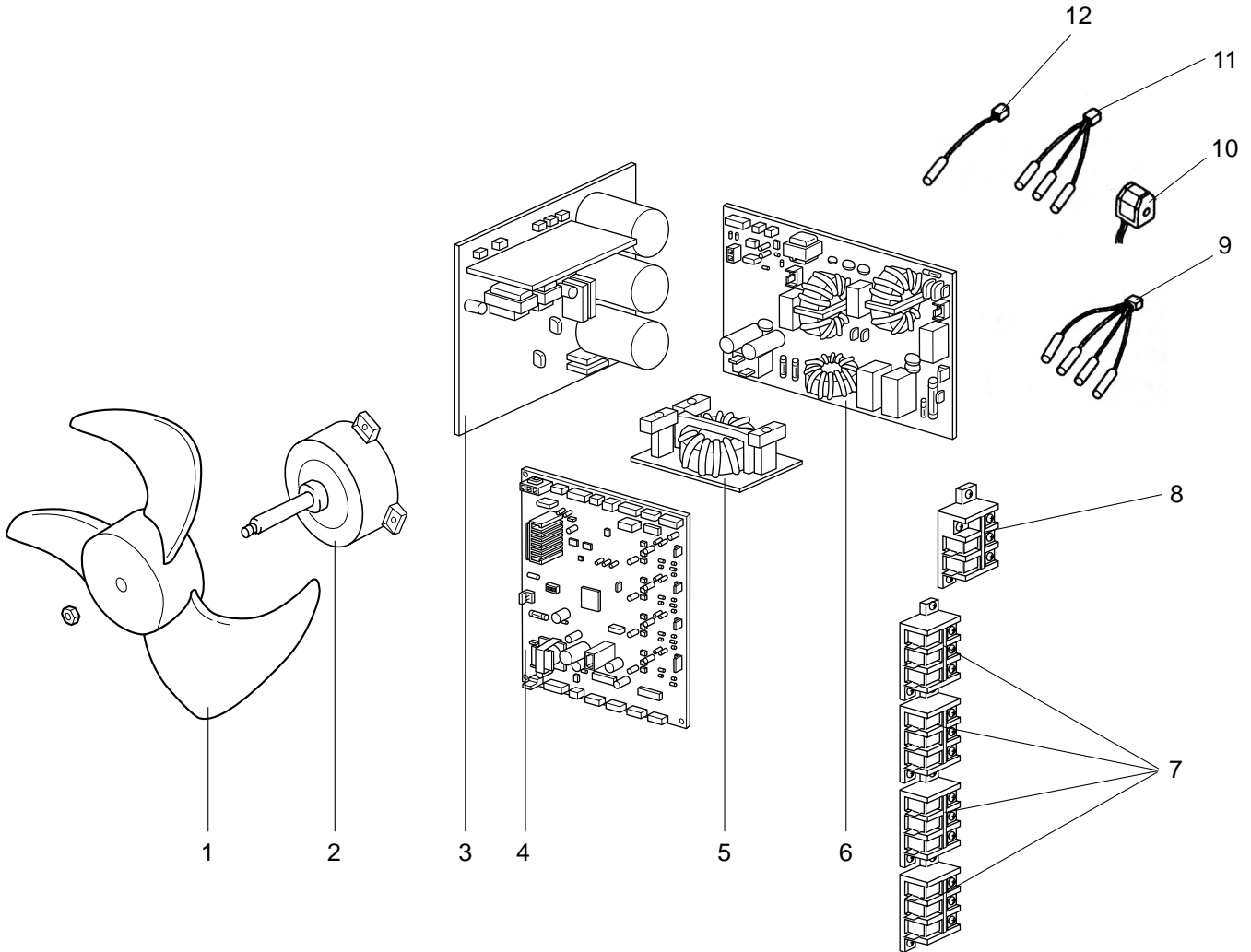

15-9. ACCESSORY

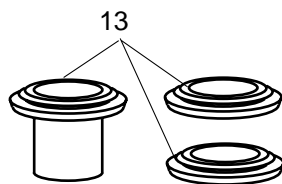

PARTS LIST (non-RoHS compliant)

MXZ-4A80VA - [E1]

15-8. OUTDOOR UNIT FUNCTIONAL PARTS AND ELECTRICAL PARTS

Part numbers that are circled are not shown in the illustration.

No.	Parts No.	Parts Name	Symbol in Wiring Diagram	Q'ty/unit	Remarks
				MXZ-4A80VA-[E1]	
1	M21 TK0 501	PROPELLER		1	
2	M21 TK0 301	OUTDOOR FAN MOTOR	MF	1	PM8H60-□□
3	T2W YH1 440	POWER BOARD		1	Including heat sink and RT64
4	T2W YH1 451	ELECTRONIC CONTROL P.C. BOARD		1	
5	M21 TK0 337	REACTOR	L	1	20A 600μH
6	T2W YH1 424	NOISE FILTER P.C. BOARD		1	
7	T2W YH1 376	TERMINAL BLOCK	TB2~5	4	Indoor unit connecting
8	T2W E64 376	TERMINAL BLOCK	TB1	1	Power supply
9	T2W E70 307	GAS PIPE TEMPERATURE THERMISTOR	RT6A,B,C,D	1	
10	T2W TK0 398	R.V. COIL	21S4	1	
11	M21 G0H 308	THERMISTOR SET	RT61,62,68	1	DEFROST, DISCHARGE, OUTDOOR HEAT EXCHANGER
12	M21 90V 309	AMBIENT TEMPERATURE THERMISTOR	RT65	1	

15-9. ACCESSORY

No.	Parts No.	Parts Name	Symbol in Wiring Diagram	Q'ty/unit	Remarks
				MXZ-4A80VA-[E1]	
13	T2W E59 704	DRAIN SOCKET ASSEMBLY		1	DRAIN SOCKET × 1 DRAIN CAP × 2

MXZ-2A30VA - E1, E2 MXZ-2A40VA - E1, E2 MXZ-2A52VA - E1, E2

16-1. OUTDOOR UNIT STRUCTURAL PARTS AND FUNCTIONAL PARTS

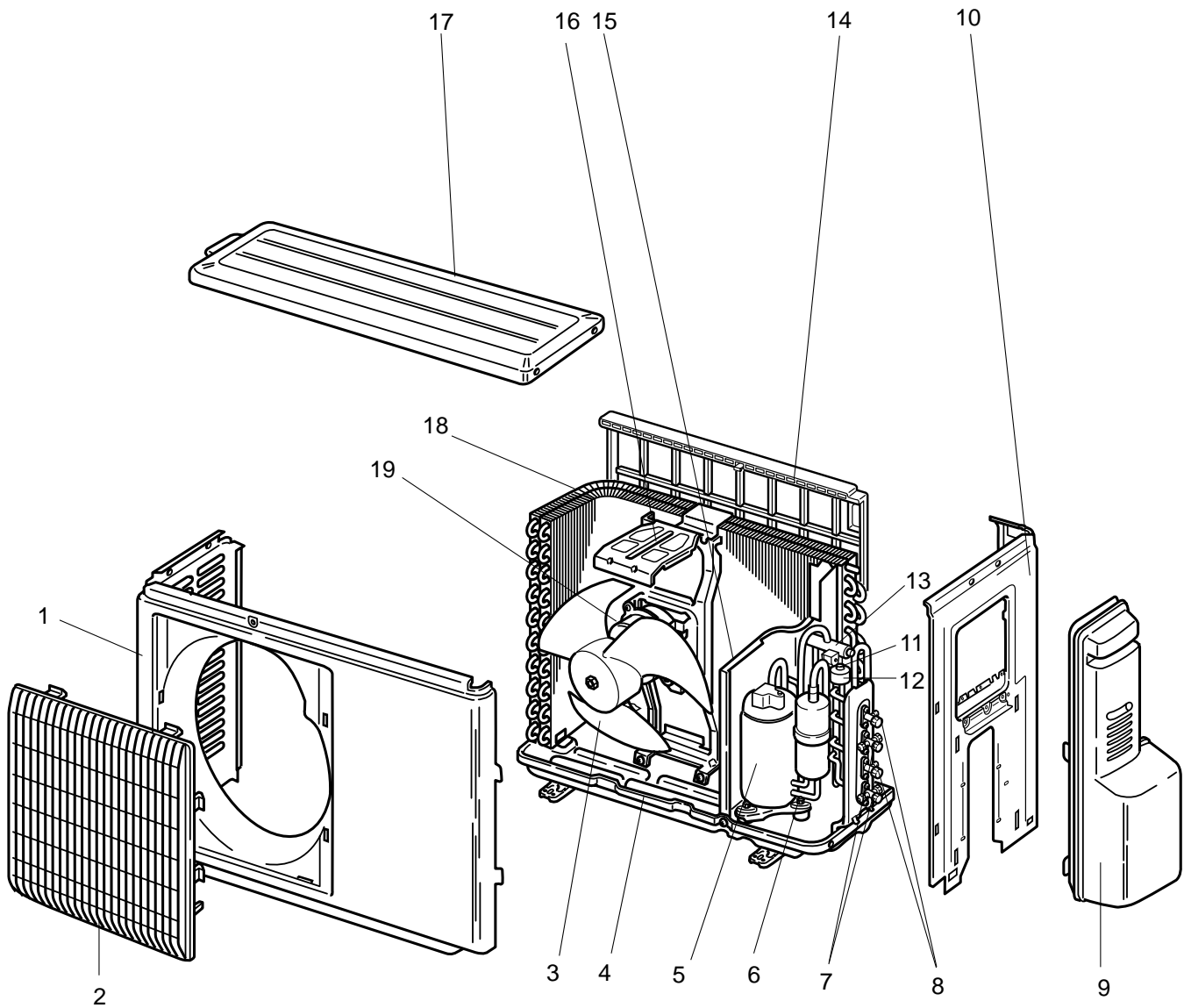

RoHS PARTS LIST (RoHS compliant)

MXZ-2A30VA - E1, E2 **MXZ-2A40VA - E1, E2** **MXZ-2A52VA - E1, E2**

16-1. OUTDOOR UNIT STRUCTURAL PARTS AND FUNCTIONAL PARTS

Part numbers that are circled are not shown in the illustration.

No.	RoHS	Part No.	Part Name	Symbol in Wiring Diagram	Q'ty/unit						Remarks
					MXZ-2A30VA-		MXZ-2A40VA-		MXZ-2A52VA-		
					E1	E2	E1	E2	E1	E2	
1	G	E12 927 232	CABINET		1	1	1	1	1	1	
2	G	E12 927 521	GRILLE		1	1	1	1	1	1	
3	G	E12 927 501	PROPELLER		1	1	1	1	1	1	
4	G	E12 A45 290	BASE		1	1	1	1	1	1	
5	G	E12 A47 900	COMPRESSOR	MC			1		1		SNB130FKCH
	G	E12 B70 900	COMPRESSOR	MC	1			1			KNB092FEDH
	G	E12 C04 900	COMPRESSOR	MC						1	SNB130FKMH
	G	E12 B93 900	COMPRESSOR	MC		1					KNB073FGDH
6	G	E12 065 506	COMPRESSOR RUBBER SET		3	3	3	3	3	3	3RUBBERS/SET
7	G	E12 927 661	STOP VALVE (GAS)		2	2	2	2	2	2	φ 9.52
8	G	E12 927 662	STOP VALVE (LIQUID)		2	2	2	2	2	2	φ 6.35
9	G	E12 A47 245	SERVICE PANEL		1	1	1	1	1	1	
10	G	E12 A47 233	BACK PANEL		1	1	1	1	1	1	
11	G	E12 735 640	EXPANSION VALVE		1	1	1	1	1	1	ROOM B
12	G	E12 A48 493	EXPANSION VALVE COIL	LEV B	1	1	1	1	1	1	
13	G	E12 A47 961	4-WAY VALVE				1		1	1	
	G	E12 927 961	4-WAY VALVE		1	1		1			
14	G	E12 929 523	CONDENSER NET				1		1	1	
	G	E12 838 523	CONDENSER NET		1	1		1			
15	G	E12 929 293	SEPARATOR				1		1	1	
	G	E12 927 293	SEPARATOR		1	1		1			
16	G	E12 929 515	MOTOR SUPPORT				1		1	1	
	G	E12 927 515	MOTOR SUPPORT		1	1		1			
17	G	E12 927 297	TOP PANEL		1	1	1	1	1	1	
18	G	E12 A47 630	OUTDOOR HEAT EXCHANGER				1		1	1	
	G	E12 B70 630	OUTDOOR HEAT EXCHANGER								
19	G	E12 A47 301	OUTDOOR FAN MOTOR	MF	1	1	1	1	1	1	RC0J50-□□
20	G	E12 339 936	CAPILLARY TUBE				4		4	4	φ3.0×φ1.4×600
21	G	E12 838 936	CAPILLARY TUBE		2	2	2	2	2	2	φ3.0×φ2.0×200
22	G	E12 735 640	EXPANSION VALVE		1	1	1	1	1	1	ROOM A
22	G	E12 A47 493	EXPANSION VALVE COIL	LEV A	1	1	1	1	1	1	

RoHS PARTS LIST (RoHS compliant)

MXZ-2A30VA - E1, E2 MXZ-2A40VA - E1, E2 MXZ-2A52VA - E1, E2

16-2. OUTDOOR UNIT ELECTRICAL PARTS

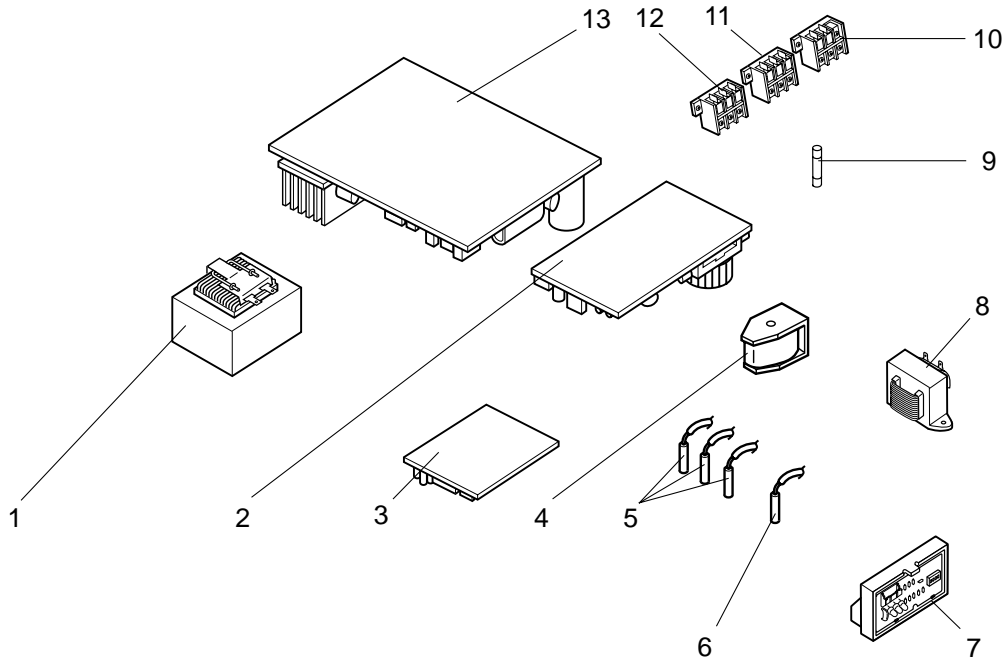

Part numbers that are circled are not shown in the illustration.

No.	RoHS	Part No.	Part Name	Symbol in Wiring Diagram	Q'ty/unit						Remarks
					MXZ-2A30VA-		MXZ-2A40VA-		MXZ-2A52VA-		
					E1	E2	E1	E2	E1	E2	
1	G	E12 838 337	REACTOR	L64	1	1	1	1	1	1	10A 23mH
2	G	E12 A47 440	POWER P.C. BOARD		1	1	1	1	1	1	
3	G	E12 A47 454	INTERFACE P.C. BOARD		1	1	1	1	1	1	
4	G	E12 A47 490	R.V. COIL	21S4	1	1	1	1	1	1	
5	G	E12 A47 308	THERMISTOR SET	RT61,62,68	1	1	1	1	1	1	DEFROST, DISCHARGE OUTDOOR HEAT EXCHANGER
6	G	E12 A47 309	AMBIENT TEMPERATURE THERMISTOR	RT65	1	1	1	1	1	1	
7	G	E12 A47 329	DISPLAY P.C. BOARD		1	1	1	1	1	1	
8	G	E12 A47 337	REACTOR	L65	1	1	1	1	1	1	2A 25mH
9	G	E12 735 382	FUSE	F61	1	1	1	1	1	1	T20AL250V
10	G	E12 A47 374	TERMINAL BLOCK	TB1	1	1	1	1	1	1	Power supply
11	G	E12 935 374	TERMINAL BLOCK	TB3	1	1	1	1	1	1	Indoor unit connecting
12	G	E12 935 374	TERMINAL BLOCK	TB2	1	1	1	1	1	1	Indoor unit connecting
13	G	E12 A47 451	INVERTER P.C. BOARD				1				Including heat sink and RT64
	G	E12 A48 451	INVERTER P.C. BOARD					1			Including heat sink and RT64
	G	E12 B70 451	INVERTER P.C. BOARD		1						Including heat sink and RT64
	G	E12 B71 451	INVERTER P.C. BOARD					1			Including heat sink and RT64
	G	E12 C04 451	INVERTER P.C. BOARD							1	Including heat sink and RT64
	G	E12 C58 451	INVERTER P.C. BOARD			1					

RoHS PARTS LIST (RoHS compliant)

MXZ-2A30VA - [E1], [E2] MXZ-2A40VA - [E1], [E2] MXZ-2A52VA - [E1], [E2]
16-3. DRAIN SOCKET

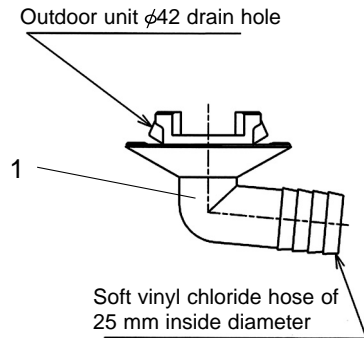

No.	RoHS	Parts No.	Parts Name	Symbol in Wiring Diagram	Q'ty/unit						Remarks
					MXZ-2A30VA-		MXZ-2A40VA-		MXZ-2A52VA-		
					[E1]	[E2]	[E1]	[E2]	[E1]	[E2]	
1	G	E12 838 704	DRAIN SOCKET		1	1	1	1	1	1	

RoHS PARTS LIST (RoHS compliant)

MXZ-3A54VA - E1, E2, E3, E4

MXZ-4A71VA - E1, E2, E3, E4

16-4. OUTDOOR UNIT STRUCTURAL PARTS AND FUNCTIONAL PARTS

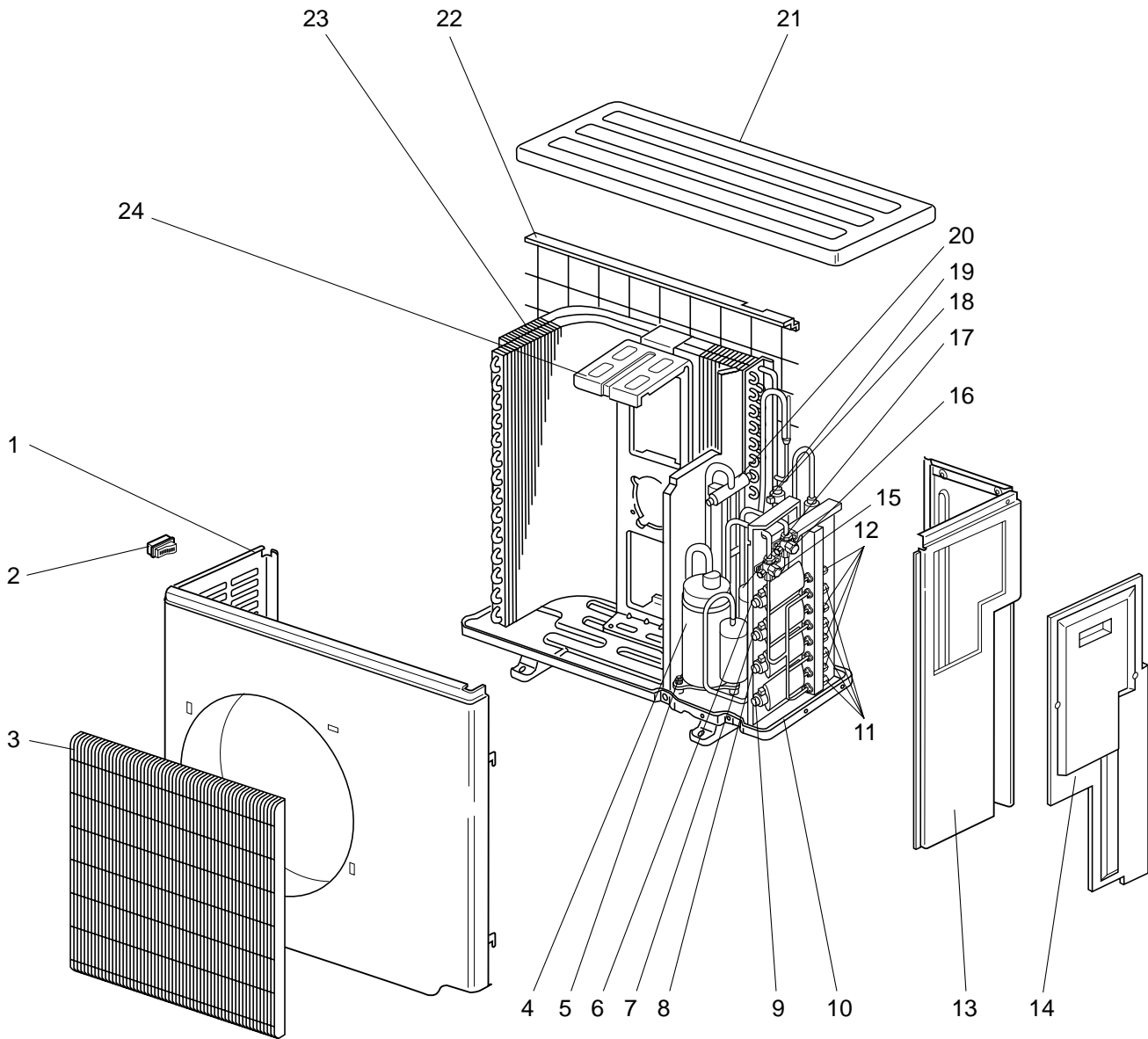

RoHS PARTS LIST (RoHS compliant)

MXZ-3A54VA - E1, E2, E3, E4

MXZ-4A71VA - E1, E2, E3, E4

16-4. OUTDOOR UNIT STRUCTURAL PARTS AND FUNCTIONAL PARTS

Part numbers that are circled are not shown in the illustration.

No.	RoHS	Parts No.	Parts Name	Symbol in Wiring Diagram	Q'ty/unit								Remarks	
					MXZ-3A54VA-				MXZ-4A71VA-					
					E1	E2	E3	E4	E1	E2	E3	E4		
1	G	E12 939 232	CABINET		1	1	1	1	1	1	1	1	1	
2	G	E12 817 009	HANDLE		1	1	1	1	1	1	1	1	1	
3	G	E12 939 521	GRILLE		1	1	1	1	1	1	1	1	1	
4	G	E12 939 900	COMPRESSOR	MC	1	1			1	1				SNB130FLDH1
	G	E12 C06 900	COMPRESSOR	MC			1				1			SNB130FLEH1
	G	E12 C18 900	COMPRESSOR	MC				1					1	SNB130FGBH1
5	G	E12 065 506	COMPRESSOR RUBBER SET		3	3	3	3	3	3	3	3	3	3RUBBERS SET
6	G	E12 851 640	EXPANSION VALVE						1	1	1	1	1	D room
	G	E12 939 494	LEV COIL	LEV D					1	1	1	1	1	D room
7	G	E12 851 640	EXPANSION VALVE		1	1	1	1	1	1	1	1	1	C room
	G	E12 938 494	LEV COIL	LEV C	1	1	1	1	1	1	1	1	1	C room
8	G	E12 851 640	EXPANSION VALVE		1	1	1	1	1	1	1	1	1	B room
	G	E12 939 493	LEV COIL	LEV B	1	1	1	1	1	1	1	1	1	B room
9	G	E12 851 640	EXPANSION VALVE		1	1	1	1	1	1	1	1	1	A room
	G	E12 938 493	LEV COIL	LEV A	1	1	1	1	1	1	1	1	1	A room
10	G	E12 939 290	BASE		1	1	1	1	1	1	1	1	1	
11	G	E12 C06 666	UNION(GAS)		3	3	3		3	3	3			φ 9.52
	G	E12 C18 666	UNION(GAS)					3					3	φ 9.52
	G	E12 C07 666	UNION(GAS)						1	1	1			φ 12.7
	G	E12 C19 666	UNION(GAS)										1	φ 12.7
12	G	E12 C06 667	UNION(LIQUID)		3	3	3		4	4	4			φ 6.35
	G	E12 C18 667	UNION(LIQUID)					3					4	φ 6.35
13	G	E12 939 233	BACK PANEL		1	1	1	1	1	1	1	1	1	
14	G	E12 939 245	SERVICE PANEL		1	1	1	1	1	1	1	1	1	
15	G	E12 C06 661	BALL VALVE (GAS) 5/8		1	1	1	1	1	1	1	1	1	φ 15.88
16	G	E12 C06 662	BALL VALVE (LIQUID) 3/8		1	1	1	1	1	1	1	1	1	φ 9.52
17	G	E12 938 959	POWER RECEIVER		1	1	1		1	1	1			
	G	E12 C18 959	POWER RECEIVER					1					1	
18	G	E12 853 640	EXPANSION VALVE		1	1	1	1	1	1	1	1	1	E
19	G	E12 819 493	LEV COIL	LEV E	1	1	1	1	1	1	1	1	1	
20	G	E12 891 961	4-WAY VALVE		1	1	1		1	1	1			
	G	E12 C18 961	4-WAY VALVE					1					1	
21	G	E12 819 297	TOP PANEL		1	1	1	1	1	1	1	1	1	
22	G	E12 939 523	REAR GUARD		1	1	1	1	1	1	1	1	1	
23	G	E12 939 630	OUTDOOR HEAT EXCHANGER		1	1	1	1	1	1	1	1	1	
24	G	E12 939 515	MOTOR SUPPORT		1	1	1	1	1	1	1	1	1	
25	G	E12 938 937	CAPILLARY TUBE		8	8	8	8	8	8	8	8	8	φ3.6×φ2.4×500
26	G	E12 939 936	CAPILLARY TUBE		3	3	3	3	4	4	4	4	4	φ4.0×φ2.8×100
27	G	E12 938 936	CAPILLARY TUBE		1	1	1	1	1	1	1	1	1	φ2.5×φ0.6×1000
28	G	E12 938 299	OIL SEPARATOR		1	1	1	1	1	1	1	1	1	

RoHS PARTS LIST (RoHS compliant)

MXZ-3A54VA - E1, E2, E3, E4

MXZ-4A71VA - E1, E2, E3, E4

16-5. OUTDOOR UNIT FUNCTIONAL PARTS AND ELECTRICAL PARTS

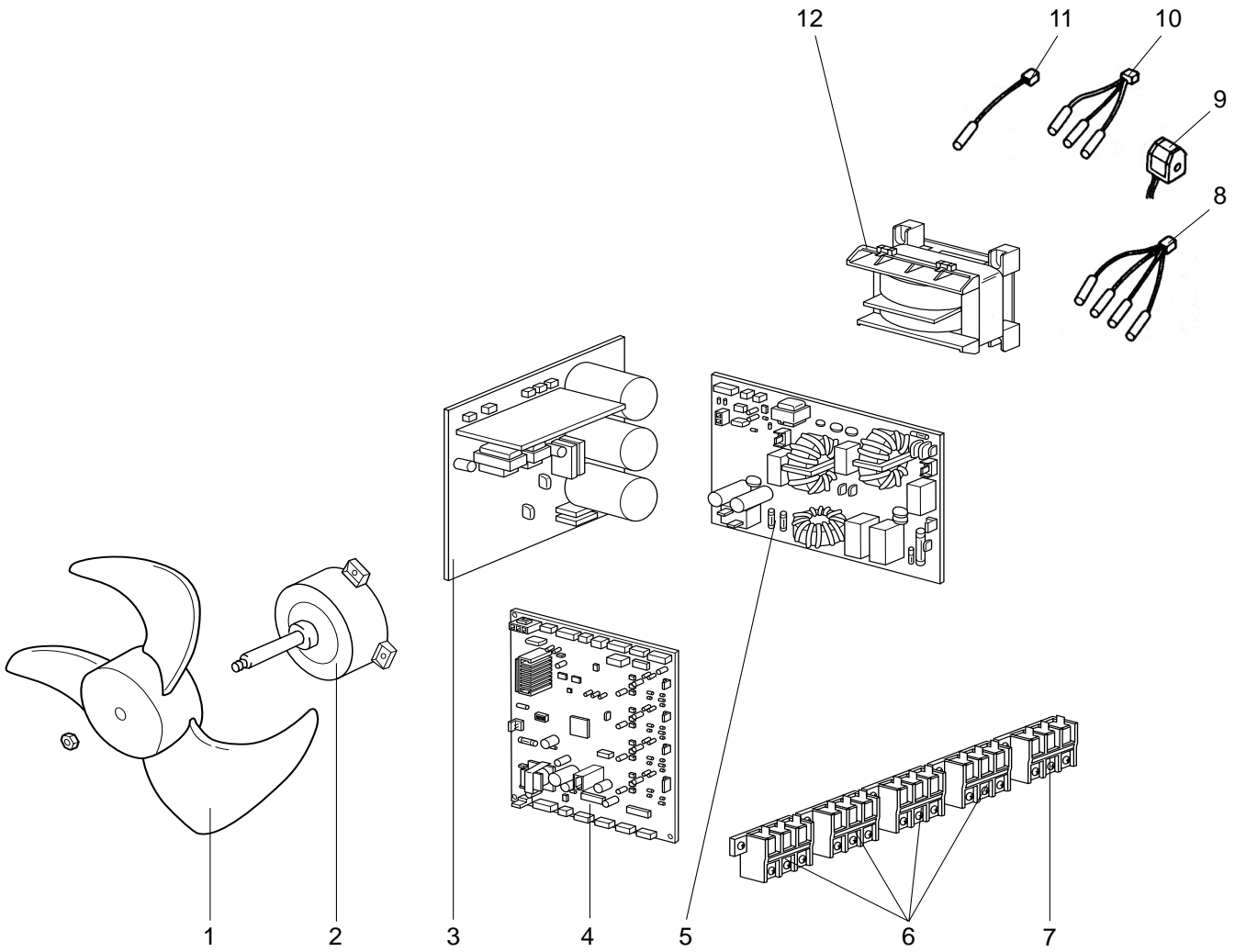

16-6. ACCESSORY

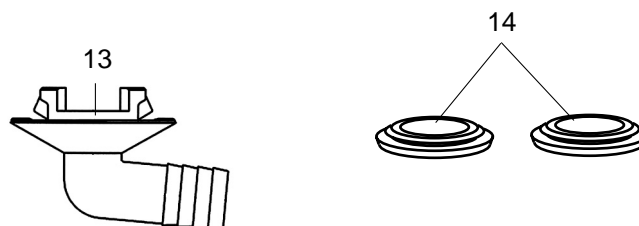

RoHS PARTS LIST (RoHS compliant)

MXZ-3A54VA - E1, E2, E3, E4

MXZ-4A71VA - E1, E2, E3, E4

16-5. OUTDOOR UNIT FUNCTIONAL PARTS AND ELECTRICAL PARTS

Part numbers that are circled are not shown in the illustration.

No.	RoHS	Parts No.	Parts Name	Symbol in Wiring Diagram	Q'ty/unit								Remarks
					MXZ-3A54VA-				MXZ-4A71VA-				
					E1	E2	E3	E4	E1	E2	E3	E4	
1	G	E12 851 501	PROPELLER		1	1	1	1	1	1	1	1	
2	G	E12 938 301	OUTDOOR FAN MOTOR	MF	1	1	1	1	1	1	1	1	RC0J60- □□
3	G	E12 939 440	POWER BOARD		1	1	1		1	1	1		Including heat sink and RT64
	G	E12 C07 440	POWER BOARD					1				1	Including heat sink and RT64
4	G	E12 938 450	ELECTRONIC CONTROL P.C. BOARD		1	1							
	G	E12 939 450	ELECTRONIC CONTROL P.C. BOARD						1	1			
	G	E12 C06 450	ELECTRONIC CONTROL P.C. BOARD				1						
	G	E12 C07 450	ELECTRONIC CONTROL P.C. BOARD								1		
	G	E12 C18 450	ELECTRONIC CONTROL P.C. BOARD					1					
5	G	E12 C19 450	ELECTRONIC CONTROL P.C. BOARD									1	
	G	E12 938 444	NOISE FILTER P.C. BOARD		1	1	1	1	1	1	1	1	
6	G	E12 927 374	TERMINAL BLOCK	TB2-5	3	3	3	3	4	4	4	4	Indoor unit connecting
7	G	E12 823 375	TERMINAL BLOCK	TB1	1	1	1	1	1	1	1	1	Power supply
8	G	E12 938 307	GAS PIPE TEMPERATURE THERMISTOR SET	RT6A,B,C	1	1	1						
	G	E12 939 307	GAS PIPE TEMPERATURE THERMISTOR SET	RT6A,B,C,D					1	1	1		
9	G	E12 939 490	R.V. COIL	21S4	1	1	1		1	1	1		
	G	E12 C18 490	R.V. COIL	21S4				1				1	
10	G	E12 938 308	THERMISTOR SET	RT61,62,68	1	1	1	1	1	1	1	1	DEFROST, DISCHARGE OUTDOOR HEAT EXCHANGER
11	G	E12 938 309	AMBIENT TEMPERATURE THERMISTOR	RT65	1	1	1	1	1	1	1	1	
12	G	E12 938 337	REACTOR	L	1	1	1	1	1	1	1	1	20A 600μH

16-6. ACCESSORY

No.	RoHS	Parts No.	Parts Name	Symbol in Wiring Diagram	Q'ty/unit								Remarks
					MXZ-3A54VA-				MXZ-4A71VA-				
					E1	E2	E3	E4	E1	E2	E3	E4	
13	G	E12 817 704	DRAIN SOCKET		1	1	1	1	1	1	1	1	
14	G	E12 444 705	DRAIN CAP		2	2	2	2	2	2	2	2	

RoHS PARTS LIST (RoHS compliant)

MXZ-3A54VA - E5, E6, E7

MXZ-4A71VA - E5, E6, E7

16-7. OUTDOOR UNIT STRUCTURAL PARTS AND FUNCTIONAL PARTS

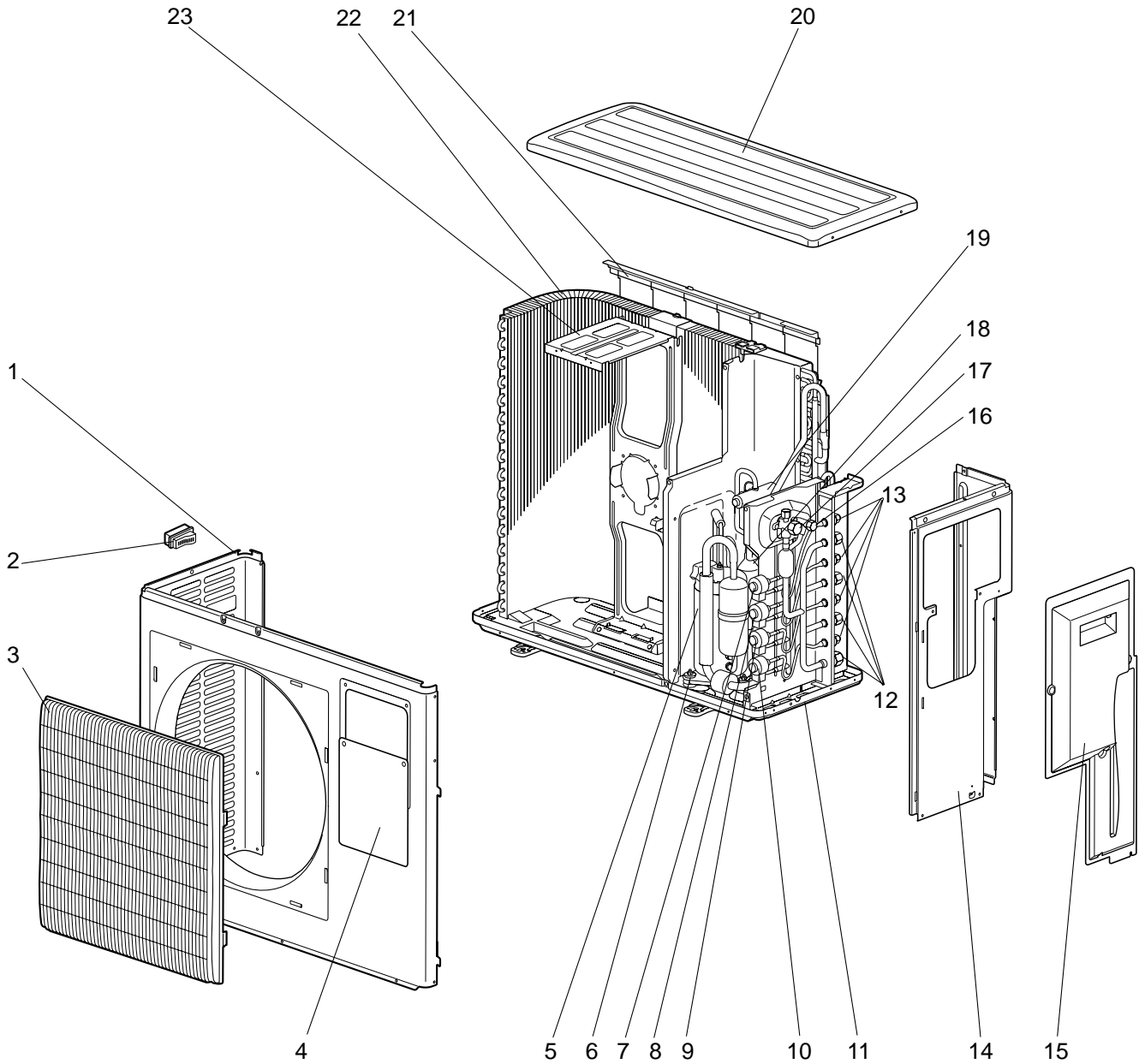

RoHS PARTS LIST (RoHS compliant)

MXZ-3A54VA - E5, E6, E7

MXZ-4A71VA - E5, E6, E7

16-7. OUTDOOR UNIT STRUCTURAL PARTS AND FUNCTIONAL PARTS

Part numbers that are circled are not shown in the illustration.

No.	ROHS	Parts No.	Parts Name	Symbol in Wiring Diagram	Q'ty/unit						Remarks
					MXZ-3A54VA-			MXZ-4A71VA-			
					E5	E6	E7	E5	E6	E7	
1	G	E12 D36 232	CABINET		1	1	1	1	1	1	
2	G	E12 817 009	HANDLE		1	1	1	1	1	1	
3	G	E12 939 521	GRILLE		1	1	1	1	1	1	
4	G	E12 D36 246	SUB PANEL		1	1	1	1	1	1	
5	G	E12 C18 900	COMPRESSOR	MC	1	1		1	1		SNB130FGBH1
	G	E12 F10 900	COMPRESSOR	MC			1			1	SNB130FGBH1T
6	G	E12 C34 506	COMPRESSOR RUBBER SET		3	3	3	3	3	3	3RUBBERS SET
7	G	E12 851 640	EXPANSION VALVE					1	1	1	D room
	G	E12 939 494	LEV COIL	LEV D				1	1	1	D room
8	G	E12 851 640	EXPANSION VALVE		1	1	1	1	1	1	C room
	G	E12 938 494	LEV COIL	LEV C	1	1	1	1	1	1	C room
9	G	E12 851 640	EXPANSION VALVE		1	1	1	1	1	1	B room
	G	E12 939 493	LEV COIL	LEV B	1	1	1	1	1	1	B room
10	G	E12 851 640	EXPANSION VALVE		1	1	1	1	1	1	A room
	G	E12 938 493	LEV COIL	LEV A	1	1	1	1	1	1	A room
11	G	E12 939 290	BASE		1	1	1	1	1	1	
12	G	E12 D36 666	UNION(GAS)		3	3	3	3	3	3	φ 9.52
	G	E12 D37 666	UNION(GAS)					1	1	1	φ 12.7
13	G	E12 D36 667	UNION(LIQUID)		3	3	3	4	4	4	φ 6.35
14	G	E12 939 233	BACK PANEL		1	1	1	1	1	1	
15	G	E12 D36 245	SERVICE PANEL		1	1	1	1	1	1	
16	G	E12 D36 662	STOP VALVE (LIQUID) 3/8		1	1	1	1	1	1	φ 9.52
17	G	E12 D36 661	STOP VALVE (GAS) 5/8		1	1	1	1	1	1	φ 15.88
18	G	E12 D36 299	OIL SEPARATOR		1	1	1	1	1	1	
19	G	E12 C18 961	4-WAY VALVE		1	1	1	1	1	1	
20	G	E12 819 297	TOP PANEL		1	1	1	1	1	1	
21	G	E12 939 523	REAR GUARD		1	1	1	1	1	1	
22	G	E12 939 630	OUTDOOR HEAT EXCHANGER		1	1	1	1	1	1	
23	G	E12 939 515	MOTOR SUPPORT		1	1	1	1	1	1	
24	G	E12 938 937	CAPILLARY TUBE		8	8	8	8	8	8	φ3.6×φ2.4×500
25	G	E12 939 936	CAPILLARY TUBE		3	3	3	4	4	4	φ4.0×φ2.8×100
26	G	E12 938 936	CAPILLARY TUBE		1	1	1	1	1	1	φ2.5×φ0.6×1000
27	G	E12 C18 959	POWER RECEIVER		1	1	1	1	1	1	
28	G	E12 853 640	EXPANSION VALVE		1	1	1	1	1	1	E
29	G	E12 819 493	LEV COIL	LEV E	1	1	1	1	1	1	

RoHS PARTS LIST (RoHS compliant)

MXZ-3A54VA - E5, E6, E7

MXZ-4A71VA - E5, E6, E7

16-8. OUTDOOR UNIT FUNCTIONAL PARTS AND ELECTRICAL PARTS

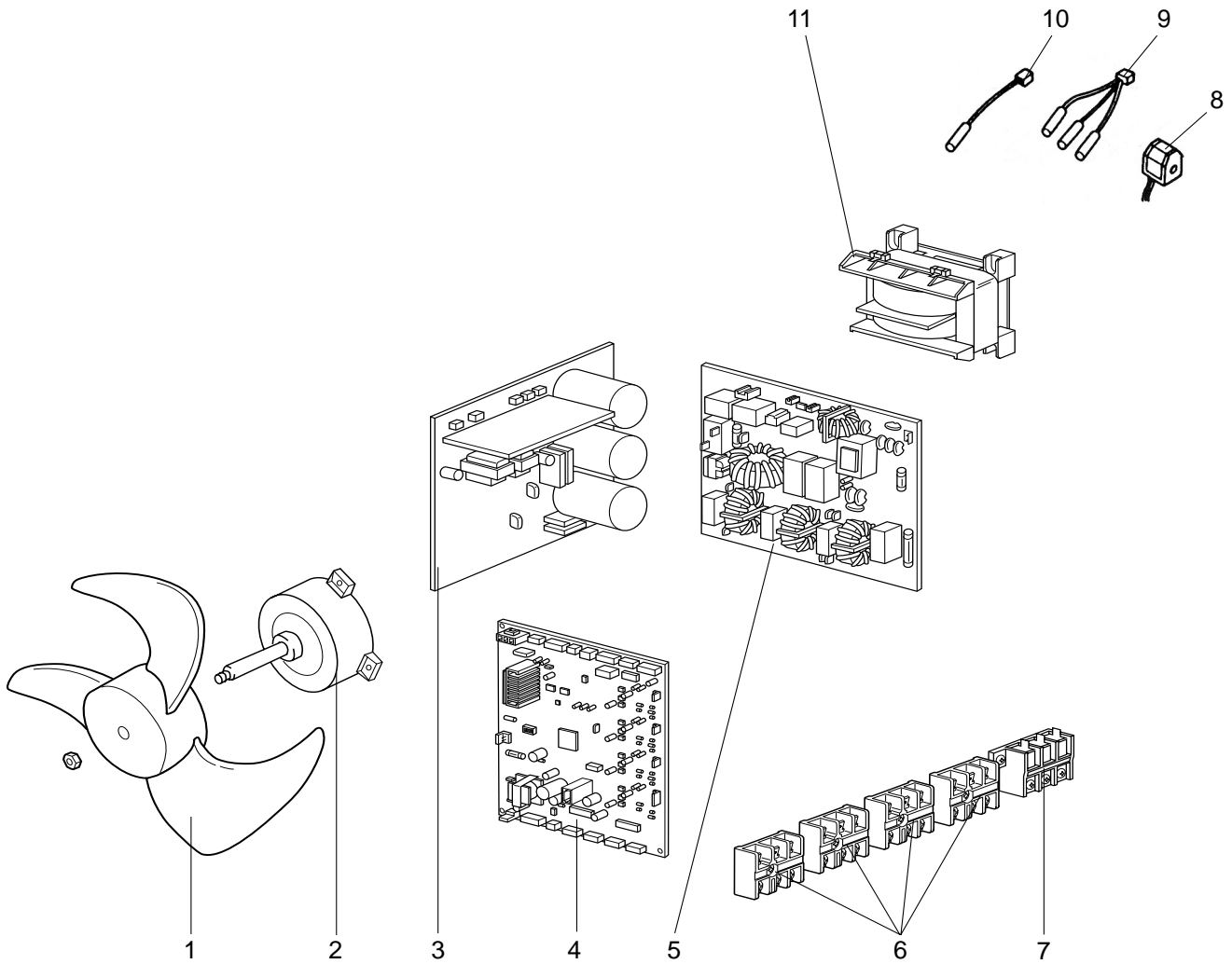

16-9. ACCESSORY

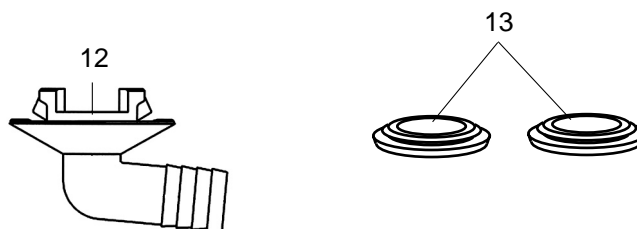

RoHS PARTS LIST (RoHS compliant)

MXZ-3A54VA - E5, E6, E7

MXZ-4A71VA - E5, E6, E7

16-8. OUTDOOR UNIT FUNCTIONAL PARTS AND ELECTRICAL PARTS

Part numbers that are circled are not shown in the illustration.

No.	RoHS	Parts No.	Parts Name	Symbol in Wiring Diagram	Q'ty/unit						Remarks
					MXZ-3A54VA-			MXZ-4A71VA-			
					E5	E6	E7	E5	E6	E7	
1	G	E12 851 501	PROPELLER		1	1	1	1	1	1	
2	G	E12 938 301	OUTDOOR FAN MOTOR	MF	1	1	1	1	1	1	RC0J60- □□
3	G	E12 C07 440	POWER BOARD		1	1	1	1	1	1	Including heat sink and RT64
4	G	E12 D36 450	ELECTRONIC CONTROL P.C. BOARD		1						
	G	E12 D87 450	ELECTRONIC CONTROL P.C. BOARD			1					
	G	E12 F10 450	ELECTRONIC CONTROL P.C. BOARD				1				
	G	E12 D37 450	ELECTRONIC CONTROL P.C. BOARD					1			
	G	E12 D88 450	ELECTRONIC CONTROL P.C. BOARD						1		
5	G	E12 F11 450	ELECTRONIC CONTROL P.C. BOARD							1	
5	G	E12 D36 444	NOISE FILTER P.C. BOARD		1	1	1	1	1	1	
6	G	E12 C92 375	TERMINAL BLOCK	TB2-5	3	3	3	4	4	4	Indoor unit connecting
7	G	E12 D69 374	TERMINAL BLOCK	TB1	1	1	1	1	1	1	Power supply
8	G	E12 C18 490	R.V. COIL	21S4	1	1	1	1	1	1	
9	G	E12 938 308	THERMISTOR SET	RT61,62,68	1	1	1	1	1	1	DEFROST DISCHARGE OUTDOOR HEAT EXCHANGER
10	G	E12 938 309	AMBIENT TEMPERATURE THERMISTOR	RT65	1	1	1	1	1	1	
11	G	E12 938 337	REACTOR	L	1	1	1	1	1	1	20A 600μH

16-9. ACCESSORY

No.	RoHS	Parts No.	Parts Name	Symbol in Wiring Diagram	Q'ty/unit						Remarks
					MXZ-3A54VA-			MXZ-4A71VA-			
					E5	E6	E7	E5	E6	E7	
12	G	E12 817 704	DRAIN SOCKET		1	1	1	1	1	1	
13	G	E12 444 705	DRAIN CAP		2	2	2	2	2	2	

RoHS PARTS LIST (RoHS compliant)

MXZ-4A80VA - E1

16-10. OUTDOOR UNIT STRUCTURAL PARTS AND FUNCTIONAL PARTS

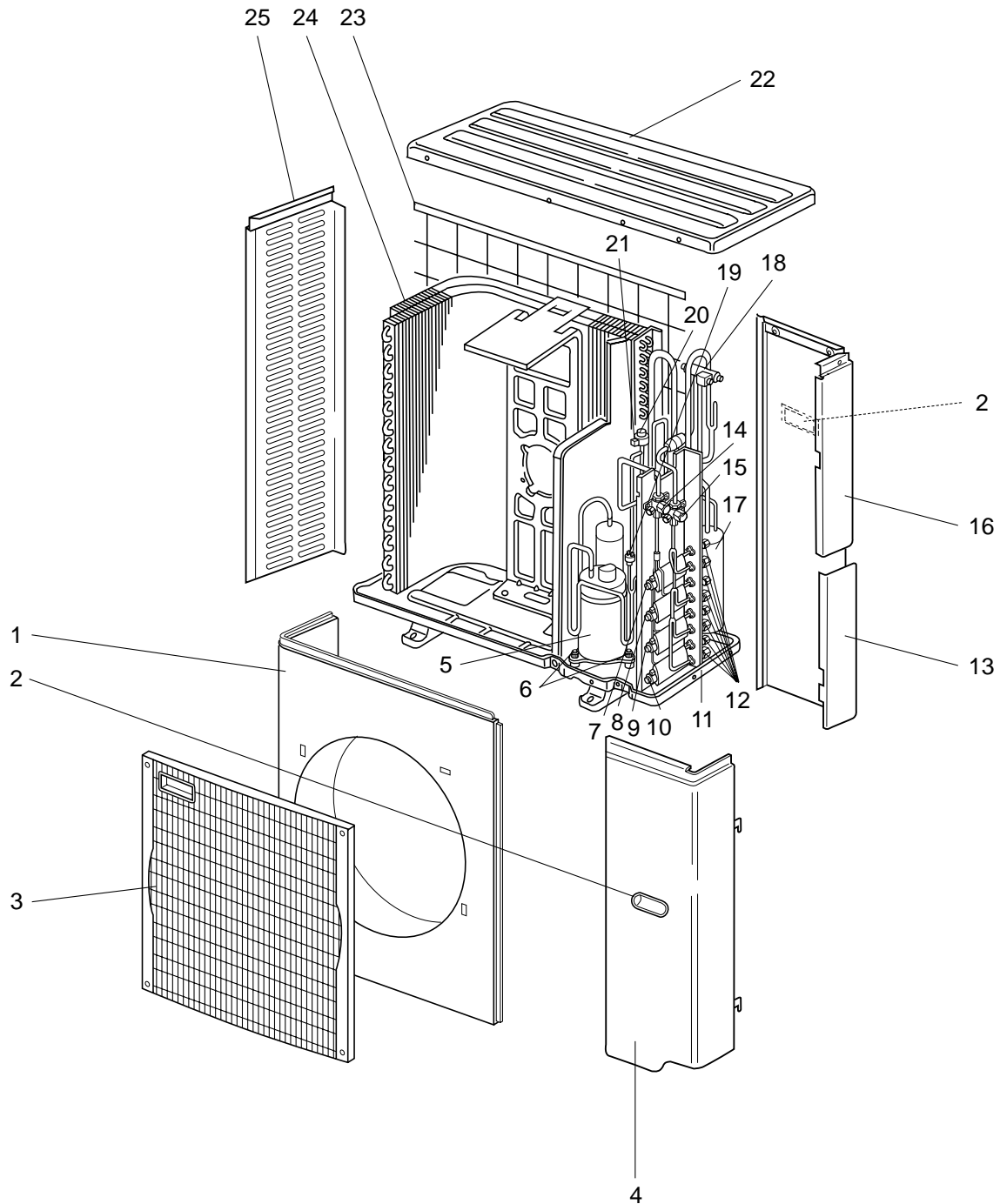

RoHS PARTS LIST (RoHS compliant)

MXZ-4A80VA - E1

16-10. OUTDOOR UNIT STRUCTURAL PARTS AND FUNCTIONAL PARTS

Part numbers that are circled are not shown in the illustration.

No.	RoHS	Parts No.	Parts Name	Symbol in Wiring Diagram	Q'ty/unit		Remarks
						MXZ-4A80VA- E1	
1	G	M21 L2V 232	FRONT PANEL			1	
2	G	M21 L2V 027	HANDLE ASSEMBLY			2	
3	G	M21 L2V 010	GRILLE			1	
4	G	M21 L2V 245	SERVICE PANEL			1	
5	G	T92 505 801	COMPRESSOR	MC		1	TNB220FMCH
6	G	M21 L2V 505	COMPRESSOR RUBBER SET			3	3RUBBERS SET
7	G	M21 L2V 401	EXPANSION VALVE			1	D room
	G	M21 L2V 654	LEV COIL	LEV D		1	D room
8	G	M21 L2V 401	EXPANSION VALVE			1	C room
	G	M21 L2V 653	LEV COIL	LEV C		1	C room
9	G	M21 L2V 401	EXPANSION VALVE			1	B room
	G	M21 L2V 652	LEV COIL	LEV B		1	B room
10	G	M21 L2V 401	EXPANSION VALVE			1	A room
	G	M21 L2V 651	LEV COIL	LEV A		1	A room
11	G	M21 L2V 290	BASE ASSEMBLY			1	
12	G	M21 L2V 644	UNION			1	$\phi 12.7, \phi 9.52, \phi 6.35$ SET
13	G	M21 L2V 247	PIPE COVER			1	
14	G	M21 L2V 667	BALL VALVE (LIQUID) 3/8			1	$\phi 9.52$
15	G	M21 L2V 668	BALL VALVE (GAS) 5/8			1	$\phi 15.88$
16	G	M21 L2V 248	REAR PANEL			1	
17	G	M21 L2V 959	POWER RECEIVER			1	
18	G	M21 L2V 642	4-WAY VALVE			1	
19	G	M21 L2V 646	HIGH PRESSURE SWITCH	HPS		1	4.8 MPa (48.9 kg/cm ²)
20	G	M21 L2V 402	EXPANSION VALVE			1	E
21	G	M21 L2V 651	LEV COIL	LEV E		1	
22	G	M21 L2V 297	TOP PANEL			1	
23	G	M21 L2V 523	REAR GUARD			1	
24	G	M21 L2V 630	OUTDOOR HEAT EXCHANGER			1	
25	G	M21 L2V 249	SIDE PANEL			1	
②⑥	G	M21 L2V 937	CAPILLARY TUBE			2	$\phi 4.0 \times \phi 2.4 \times 400$
②⑦	G	M21 L2V 936	CAPILLARY TUBE			4	$\phi 4.0 \times \phi 2.8 \times 90$
②⑧	G	M21 L2V 938	CAPILLARY TUBE			1	$\phi 2.5 \times \phi 0.6 \times 1000$
②⑨	G	M21 L2V 656	OIL SEPARATOR			1	

RoHS PARTS LIST (RoHS compliant)

MXZ-4A80VA - E1

16-11. OUTDOOR UNIT FUNCTIONAL PARTS AND ELECTRICAL PARTS

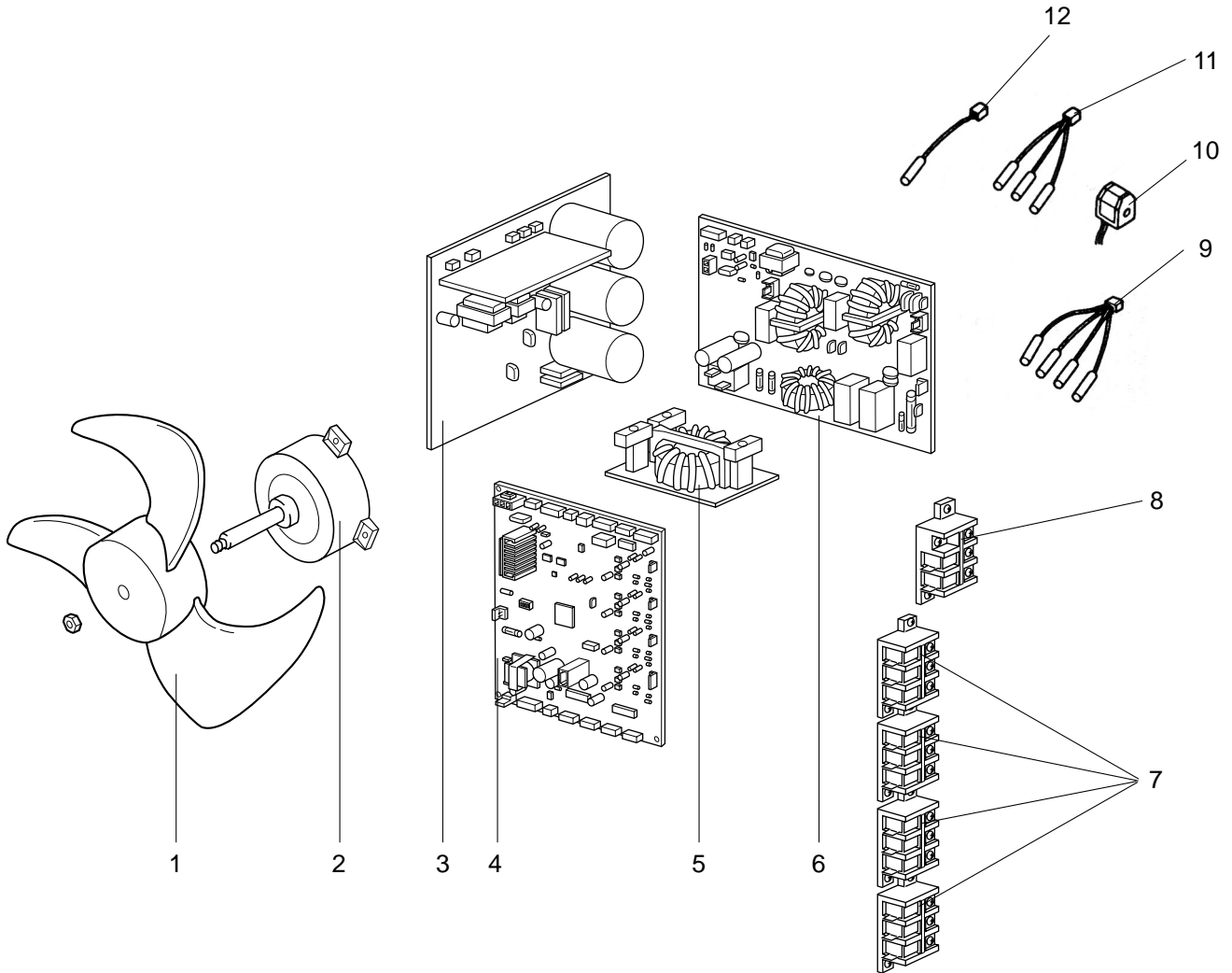

16-12. ACCESSORY

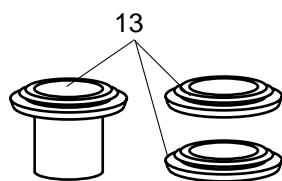

RoHS PARTS LIST (RoHS compliant)

MXZ-4A80VA - [E1]

16-11. OUTDOOR UNIT FUNCTIONAL PARTS AND ELECTRICAL PARTS

Part numbers that are circled are not shown in the illustration.

No.	RoHS	Parts No.	Parts Name	Symbol in Wiring Diagram	Q'ty/unit	Remarks
					MXZ-4A80VA-[E1]	
1	G	M21 L2V 501	PROPELLER		1	
2	G	M21 L2V 301	OUTDOOR FAN MOTOR	MF	1	PM8H60-□□
3	G	T2W L2V 440	POWER BOARD		1	Including heat sink and RT64
4	G	T2W L2V 451	ELECTRONIC CONTROL P.C. BOARD		1	
5	G	M21 L2V 337	REACTOR	L	1	20A 600μH
6	G	T2W L2V 424	NOISE FILTER P.C. BOARD		1	
7	G	T2W L2V 376	TERMINAL BLOCK	TB2~5	4	Indoor unit connecting
8	G	T2W L2V 377	TERMINAL BLOCK	TB1	1	Power supply
9	G	M21 L2V 307	GAS PIPE TEMPERATURE THERMISTOR	RT6A,B,C,D	1	
10	G	T2W L2V 398	R.V. COIL	21S4	1	
11	G	M21 L2V 308	THERMISTOR SET	RT61,62,68	1	DEFROST, DISCHARGE, OUTDOOR HEAT EXCHANGER
12	G	M21 L2V 309	AMBIENT TEMPERATURE THERMISTOR	RT65	1	

16-12. ACCESSORY

No.	RoHS	Parts No.	Parts Name	Symbol in Wiring Diagram	Q'ty/unit	Remarks
					MXZ-4A80VA-[E1]	
13	G	T2W L2V 704	DRAIN SOCKET ASSEMBLY		1	DRAIN SOCKET × 1 DRAIN CAP × 2

RoHS PARTS LIST (RoHS compliant)

MXZ-4A80VA - E2 MXZ-5A100VA - E1

16-13. OUTDOOR UNIT STRUCTURAL PARTS AND FUNCTIONAL PARTS

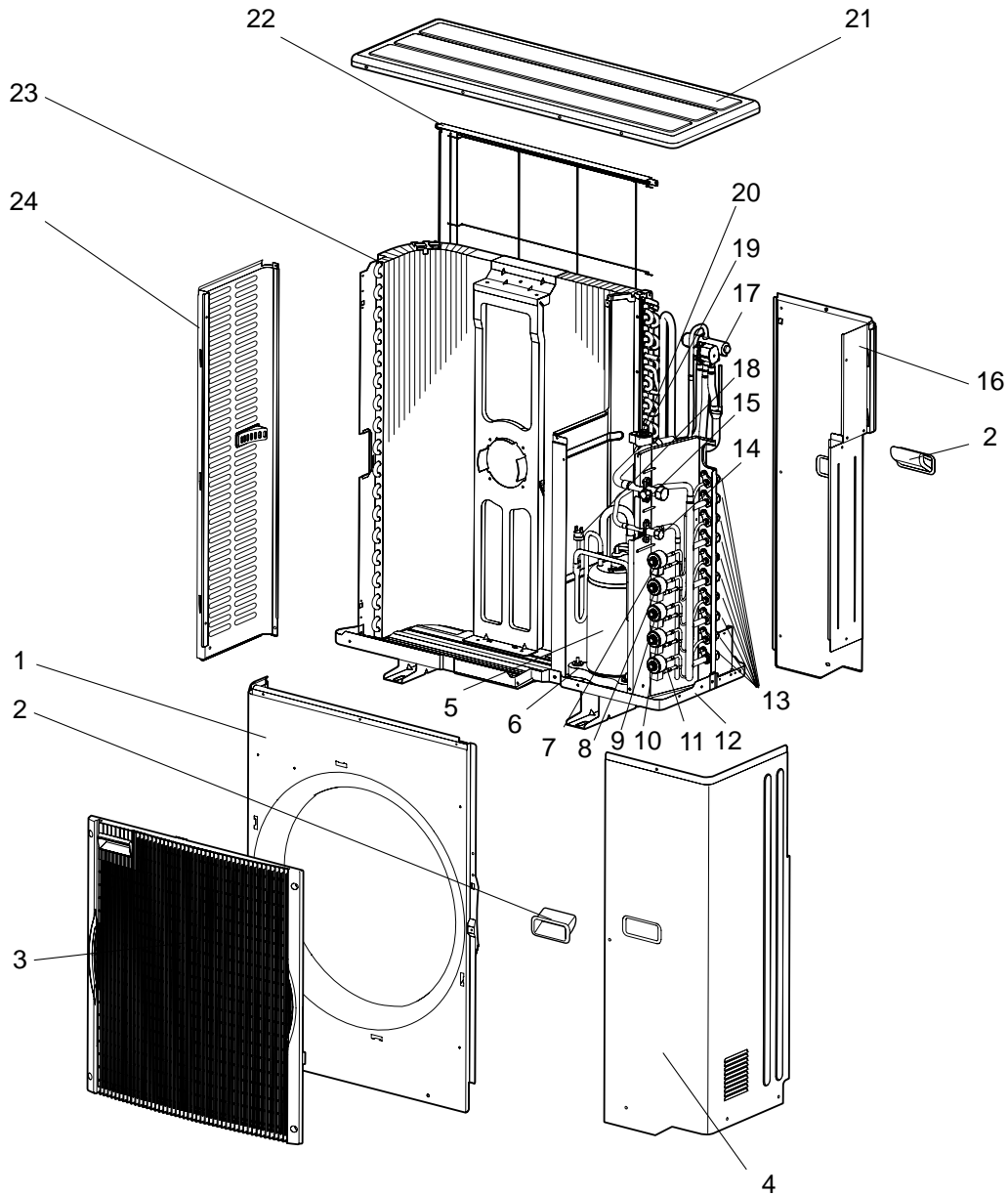

RoHS PARTS LIST (RoHS compliant)

MXZ-4A80VA - [E2] MXZ-5A100VA - [E1]

16-13. OUTDOOR UNIT STRUCTURAL PARTS AND FUNCTIONAL PARTS

Part numbers that are circled are not shown in the illustration.

No.	RoHS	Parts No.	Parts Name	Symbol in Wiring Diagram	Q'ty/unit		Remarks
					MXZ-4A80VA-[E2]	MXZ-5A100VA-[E1]	
1	G	M21 0A2 232	FRONT PANEL		1	1	
2	G	M21 0A2 027	HANDLE ASSEMBLY		2	2	
3	G	M21 L2V 010	GRILLE		1	1	
4	G	M21 0A2 245	SERVICE PANEL		1	1	
5	G	T92 505 801	COMPRESSOR	MC	1	1	TNB220FMCH
6	G	M21 L2V 505	COMPRESSOR RUBBER SET		3	3	3RUBBERS SET
7	G	M21 L2V 401	EXPANSION VALVE			1	E room
	G	M21 0A2 651	LEV COIL	LEV E		1	E room
8	G	M21 L2V 401	EXPANSION VALVE		1	1	D room
	G	M21 L2V 654	LEV COIL	LEV D	1	1	D room
9	G	M21 L2V 401	EXPANSION VALVE		1	1	C room
	G	M21 L2V 653	LEV COIL	LEV C	1	1	C room
10	G	M21 L2V 401	EXPANSION VALVE		1	1	B room
	G	M21 L2V 652	LEV COIL	LEV B	1	1	B room
11	G	M21 L2V 401	EXPANSION VALVE		1	1	A room
	G	M21 L2V 651	LEV COIL	LEV A	1	1	A room
12	G	M21 0A2 290	BASE ASSEMBLY		1	1	
13	G	M21 0A2 644	UNION		1	1	$\phi 12.7, \phi 9.52, \phi 6.35$ SET
14	G	M21 0A2 668	STOP VALVE (LIQUID) 3/8		1	1	$\phi 9.52$
15	G	M21 0A2 667	STOP VALVE (GAS) 5/8		1	1	$\phi 15.88$
16	G	M21 0A2 248	REAR PANEL		1	1	
17	G	M21 L2V 642	4-WAY VALVE		1	1	
18	G	M21 L2V 646	HIGH PRESSURE SWITCH	HPS	1	1	4.8 MPa (48.9 kg/cm ²)
19	G	M21 L2V 402	EXPANSION VALVE		1		F
	G	M21 0A2 402	EXPANSION VALVE			1	F
20	G	M21 0A2 652	LEV COIL	LEV F	1	1	
21	G	M21 L2V 297	TOP PANEL		1	1	
22	G	M21 0A2 523	REAR GUARD		1	1	
23	G	M21 0A3 630	OUTDOOR HEAT EXCHANGER		1		
	G	T2W 0A2 630	OUTDOOR HEAT EXCHANGER			1	
24	G	M21 L2V 249	SIDE PANEL		1	1	
25	G	M21 L2V 959	POWER RECEIVER		1	1	
26	G	M21 0A2 937	CAPILLARY TUBE		2	2	$\phi 3.0 \times \phi 2.0 \times 300$
27	G	M21 0A2 936	CAPILLARY TUBE		4	5	$\phi 4.0 \times \phi 2.8 \times 100$
28	G	M21 L2V 938	CAPILLARY TUBE		1	1	$\phi 2.5 \times \phi 0.6 \times 1000$
29	G	M21 L2V 656	OIL SEPARATOR		1	1	

RoHS PARTS LIST (RoHS compliant)

MXZ-4A80VA - E2 MXZ-5A100VA - E1

16-14. OUTDOOR UNIT FUNCTIONAL PARTS AND ELECTRICAL PARTS

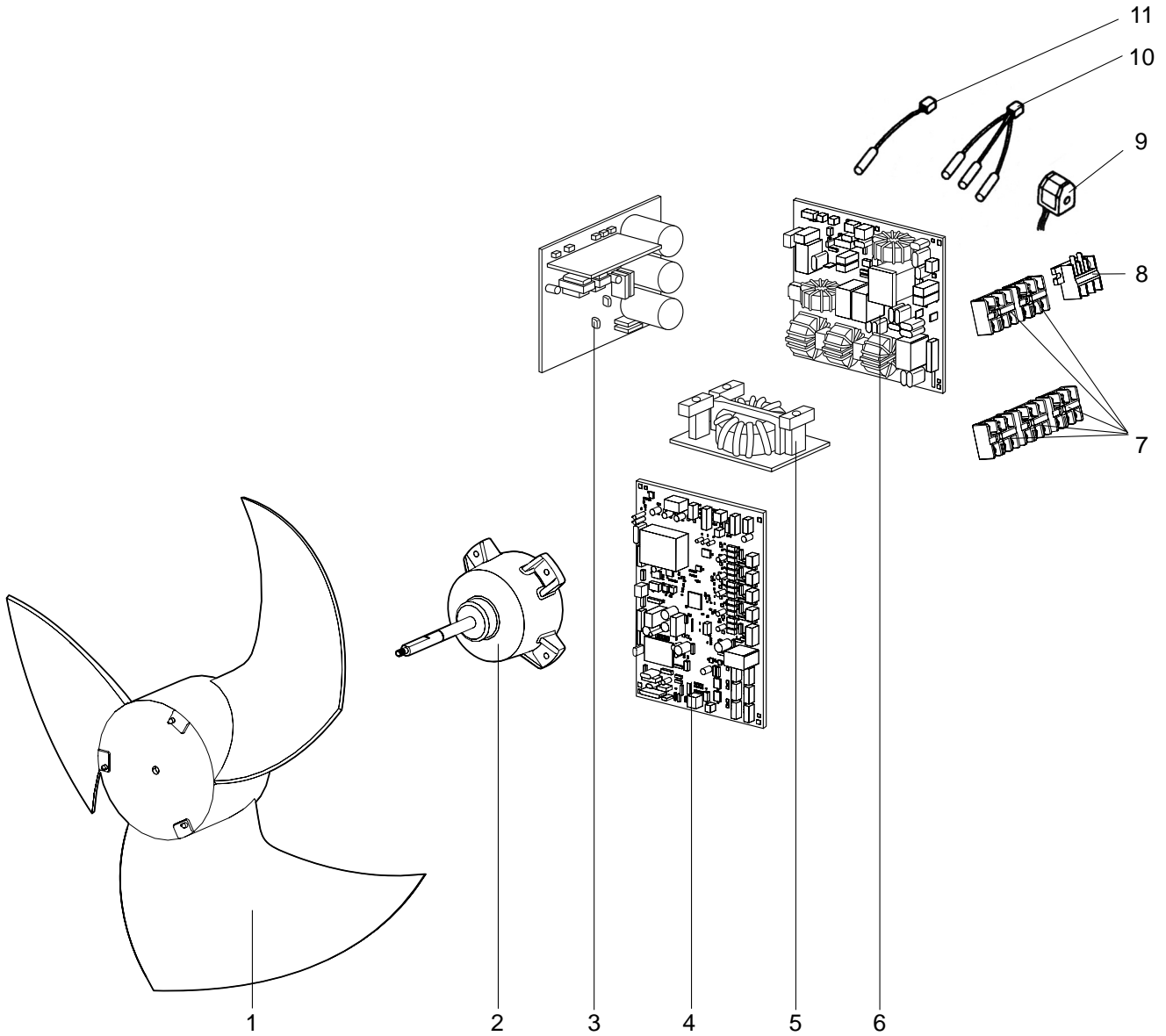

16-15. ACCESSORY

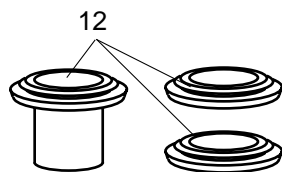

RoHS PARTS LIST (RoHS compliant)

MXZ-4A80VA - [E2] MXZ-5A100VA - [E1]

16-14. OUTDOOR UNIT FUNCTIONAL PARTS AND ELECTRICAL PARTS

Part numbers that are circled are not shown in the illustration.

No.	RoHS	Parts No.	Parts Name	Symbol in Wiring Diagram	Q'ty/unit		Remarks
					MXZ-4A80VA-[E2]	MXZ-5A100VA-[E1]	
1	G	M21 L2V 501	PROPELLER		1	1	
2	G	M21 L2V 301	OUTDOOR FAN MOTOR	MF	1	1	PM8H60-□□
3	G	M21 0A1 440	POWER BOARD		1	1	Including heat sink and RT64
4	G	T2W 0A3 451	ELECTRONIC CONTROL P.C. BOARD		1		
	G	T2W 0A2 451	ELECTRONIC CONTROL P.C. BOARD			1	
5	G	M21 L2V 337	REACTOR	L	1	1	20A 600μH
6	G	M21 0A0 424	NOISE FILTER P.C. BOARD		1	1	
7	G	T2W 0A2 376	TERMINAL BLOCK	TB2~6	4	5	Indoor unit connecting
8	G	T2W L2V 377	TERMINAL BLOCK	TB1	1	1	Power supply
9	G	T2W L2V 398	R.V. COIL	21S4	1	1	
10	G	M21 L2V 308	THERMISTOR SET	RT61,62,68	1	1	DEFROST, DISCHARGE, OUTDOOR HEAT EXCHANGER
11	G	M21 0A2 309	AMBIENT TEMPERATURE THERMISTOR	RT65	1	1	

16-15. ACCESSORY

No.	RoHS	Parts No.	Parts Name	Symbol in Wiring Diagram	Q'ty/unit		Remarks
					MXZ-4A80VA-[E2]	MXZ-5A100VA-[E1]	
12	G	T2W L2V 704	DRAIN SOCKET ASSEMBLY		1	1	DRAIN SOCKET × 1 DRAIN CAP × 2

17-1. DIFFERENT-DIAMETER PIPE

MXZ-3A54 MXZ-4A71 MXZ-4A80 MXZ-5A100	Model name	Connected pipes diameter	Diameter A	Diameter B	Length C
For different-diameter pipes	MAC-A454JP	$\phi 9.52 - \phi 12.7$ (3/8) (1/2)	$\phi 9.52$ (3/8)	$\phi 12.7$ (1/2)	69
	MAC-A455JP	$\phi 12.7 - \phi 9.52$ (1/2) (3/8)	$\phi 12.7$ (1/2)	$\phi 9.52$ (3/8)	65
	MAC-A456JP	$\phi 12.7 - \phi 15.88$ (1/2) (5/8)	$\phi 12.7$ (1/2)	$\phi 15.88$ (5/8)	66.5
	PAC-493PI	$\phi 6.35 - \phi 9.52$ (1/4) (3/8)	$\phi 6.35$ (1/4)	$\phi 9.52$ (3/8)	60.5
	PAC-SG76RJ-E	$\phi 9.52 - \phi 15.88$ (3/8) (5/8)	$\phi 9.52$ (3/8)	$\phi 15.88$ (5/8)	101.5

Unit: mm (inch)

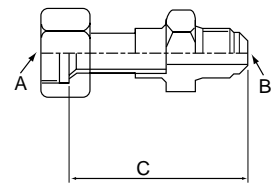

17-2. OUTLET GUIDE

Changes air discharge direction.

Applied unit	Model name	Model code
MXZ-2A30 MXZ-2A40 MXZ-2A52 MXZ-3A54 MXZ-4A71	MAC-889SG	506-889
MXZ-4A80 MXZ-5A100	MAC-855SG	51H-855

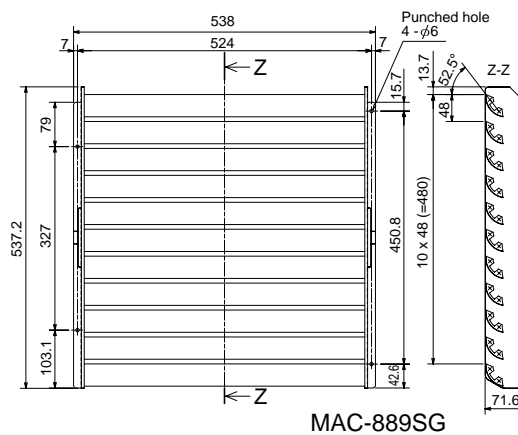

MAC-889SG

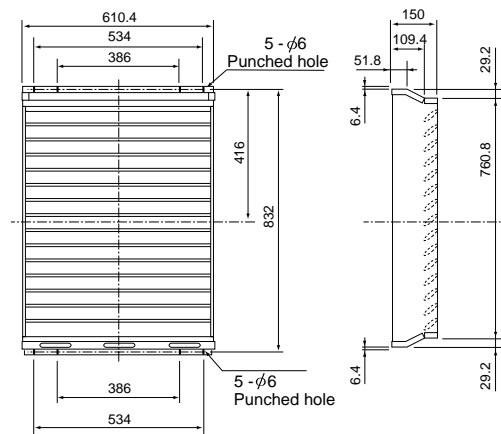

MAC-855SG

MITSUBISHI ELECTRIC CORPORATION

HEAD OFFICE: TOKYO BLDG., 2-7-3, MARUNOUCHI, CHIYODA-KU, TOKYO 100-8310, JAPAN

© Copyright 2005 MITSUBISHI ELECTRIC CORPORATION

Distributed in Feb. 2012. No.OB377 REVISED EDITION-J

Distributed in Jun. 2011. No.OB377 REVISED EDITION-I

Distributed in Dec. 2008. No.OB377 REVISED EDITION-H 6

Distributed in Sep. 2008. No.OB377 REVISED EDITION-G 6

Distributed in Dec. 2007. No.OB377 REVISED EDITION-F 8

Distributed in Aug. 2007. No.OB377 REVISED EDITION-E 8

Distributed in May 2007. No.OB377 REVISED EDITION-D 8

Distributed in Feb. 2007. No.OB377 REVISED EDITION-C 8

Distributed in Oct. 2006. No.OB377 REVISED EDITION-B 8

Distributed in Dec. 2005. No.OB377 REVISED EDITION-A 8

Distributed in Feb. 2005. No.OB377 8

Made in Japan

New publication, effective Feb. 2012

Specifications are subject to change without notice.