

Revision B:

- **E2** has been added.

Please void OBH468 REVISED EDITION-A.

INDOOR UNIT

SERVICE MANUAL

**No. OBH468
REVISED EDITION-B**

Wireless type Models

MSZ-GC22VA	- E1
MSZ-GC22VA	- E2
MSZ-GC25VA	- E1
MSZ-GC25VA	- E2
MSZ-GC35VA	- E1
MSZ-GC35VA	- E2

Outdoor unit service manual
MUZ-GC-VA Series (OBH469)
MXZ-A-VA Series (OB377)
MXZ-8A140A (OC316)

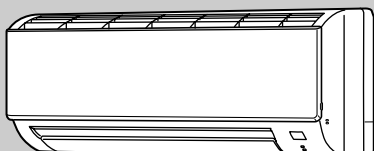

CONTENTS

1. TECHNICAL CHANGES	2
2. PART NAMES AND FUNCTIONS.....	2
3. SPECIFICATION.....	3
4. NOISE CRITERIA CURVES	4
5. OUTLINES AND DIMENSIONS	5
6. WIRING DIAGRAM	6
7. REFRIGERANT SYSTEM DIAGRAM	6
8. SERVICE FUNCTIONS	7
9. MICROPROCESSOR CONTROL	9
10. TROUBLESHOOTING.....	14
11. DISASSEMBLY INSTRUCTIONS.....	26

PARTS CATALOG (OBB468)

NOTE:
 RoHS compliant products have <G> mark on the spec name plate.



Revision A:

- 10.TROUBLESHOOTING has been corrected.
- Color of lead wire (indoor fan motor : sensor part) of 10-5."Trouble criterion of main parts" has been corrected.
- 10-6."ⒶCheck of indoor fan motor" has been corrected.

Revision B:

- **E2** has been added.

1 TECHNICAL CHANGES

MSZ-GA22VA -E1 → MSZ-GC22VA -E1
MSZ-GA25VA -E1 → MSZ-GC25VA -E1
MSZ-GA35VA -E1 → MSZ-GC35VA -E1

1. Indoor model has been changed.

MSZ-GC22VA -E1 → MSZ-GC22VA -E2
MSZ-GC25VA -E1 → MSZ-GC25VA -E2
MSZ-GC35VA -E1 → MSZ-GC35VA -E2

1. Panel has been changed.

2 PART NAMES AND FUNCTIONS

MSZ-GC22VA
MSZ-GC25VA
MSZ-GC35VA

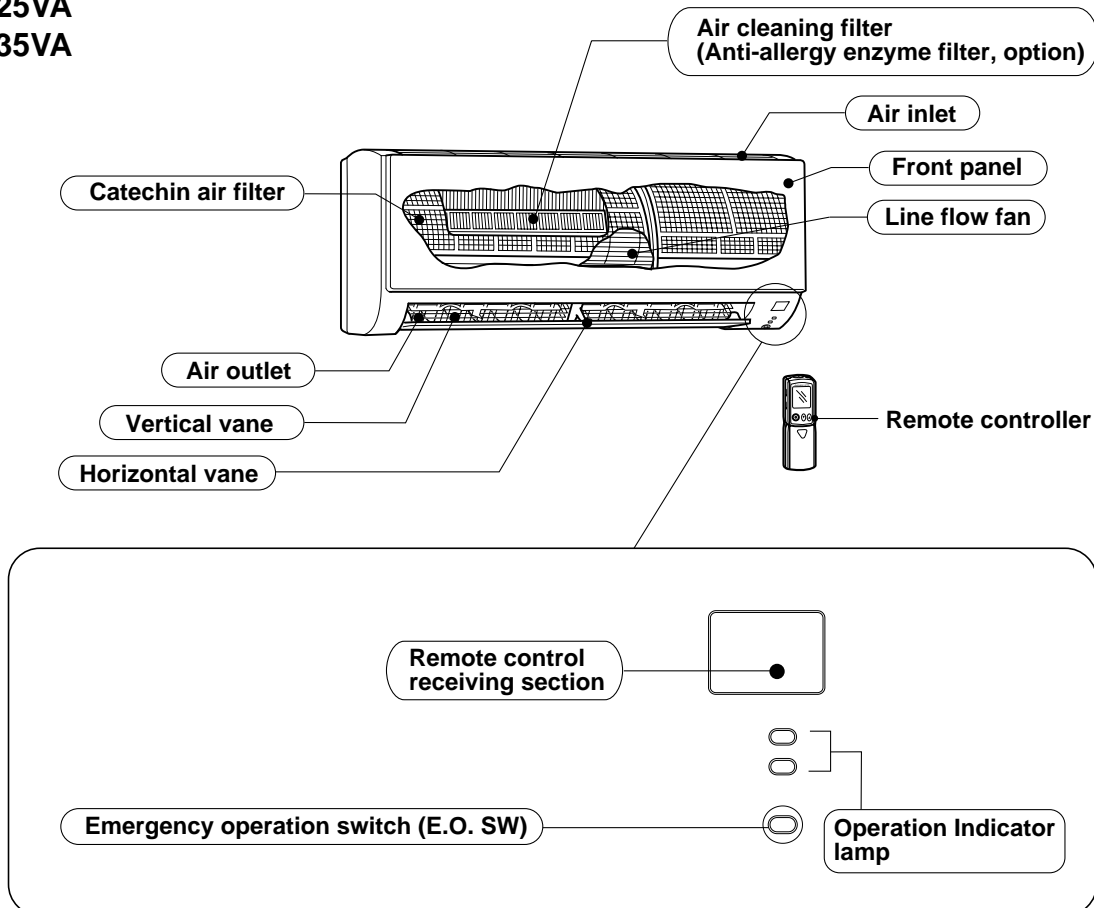

MSZ-GC22VA
MSZ-GC25VA
MSZ-GC35VA

ACCESSORIES

①	Installation plate	1
②	Installation plate fixing screw 4 × 25 mm	5
③	Remote controller holder	1
④	Fixing screw for ③ 3.5 × 1.6 mm (Black)	2
⑤	Battery (AAA) for remote controller	2
⑥	Wireless remote controller	1
⑦	Felt tape (Used for left or left-rear piping)	1

3

SPECIFICATION

Indoor model			MSZ-GC22VA		MSZ-GC25VA		MSZ-GC35VA	
Function			Cooling	Heating	Cooling	Heating	Cooling	Heating
Power supply			Single phase 230V,50Hz					
Capacity	Air flow(Super High)	m ³ /h	576	600	576	600	552	570
	Air flow(High/Med./Low)	m ³ /h	462/354/246	480/378/276	462/354/246	480/378/276	444/330/234	462/354/246
Electrical data	Running current *1	A	0.22					
	Power input *1	W	40					
	Fan motor current *1	A	0.22					
Fan motor	Model	RC4V18-BA or CA						
Dimensions W×H×D		mm	788×295×234					
Weight		kg	9					
Special remarks	Air direction		4					
	Sound level (Super High)	dB(A)	43					
	Sound level (High/Med./Low)	dB(A)	36/29/21				36/29/22	
	Fan speed (Super High)	rpm	1,070	1,100	1,070	1,100	1,110	1,140
	Fan speed (High/Med./Low)	rpm	890/720/550	920/760/600	890/720/550	920/760/600	930/740/580	960/780/600
Fan speed regulator		4						
Remote controller model			KM05B					

NOTE : Test conditions are based on ISO 5151

Cooling : Indoor Dry-bulb temperature 27°C Wet-bulb temperature 19°C

Outdoor Dry-bulb temperature 35°C

Heating : Indoor Dry-bulb temperature 20°C

Outdoor Dry-bulb temperature 7°C Wet-bulb temperature 6°C

Refrigerant piping length (one way): 5m

*1 Measured under rated operating frequency.

Specifications and rating conditions of main electric parts

Fuse	(F11)	T3.15AL 250V
Horizontal vane motor	(MV)	12V DC
Varistor	(NR11)	S10K320E3K1(ERZV14D471)
Terminal block	(TB)	3P

4

NOISE CRITERIA CURVES

MSZ-GC22VA MSZ-GC25VA

FAN SPEED	FUNCTION	SPL(dB(A))	LINE
Super High	COOLING	43	●—●
	HEATING	43	○—○

MSZ-GC35VA

FAN SPEED	FUNCTION	SPL(dB(A))	LINE
Super High	COOLING	43	●—●
	HEATING	43	○—○

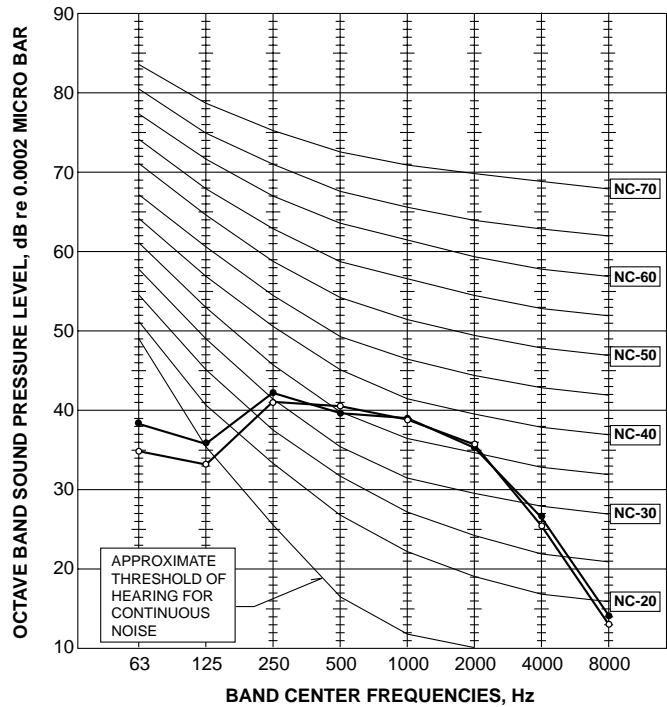
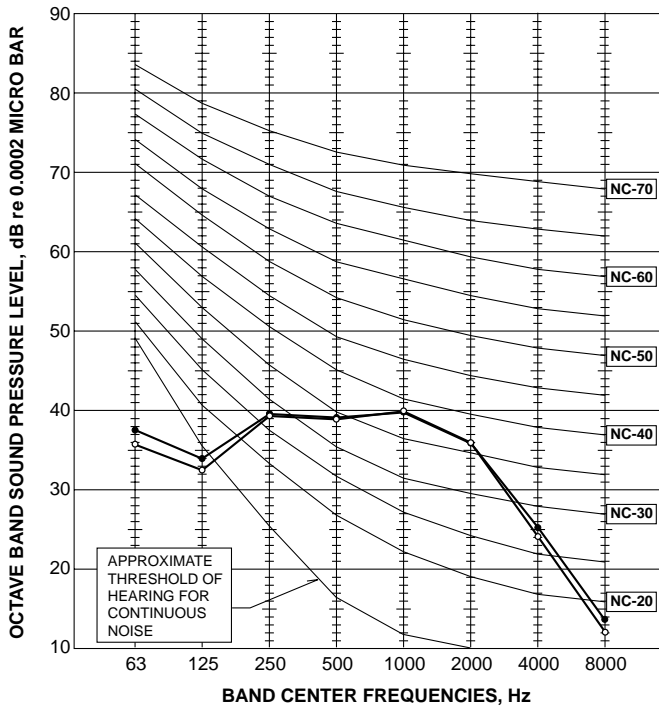

Test conditions

Cooling : Dry-bulb temperature 27°C Wet-bulb temperature 19°C
 Heating : Dry-bulb temperature 20°C

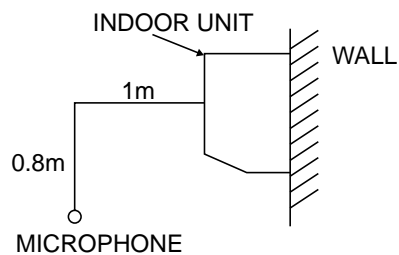

5

OUTLINES AND DIMENSIONS

MSZ-GC22VA
MSZ-GC25VA
MSZ-GC35VA

Unit : mm

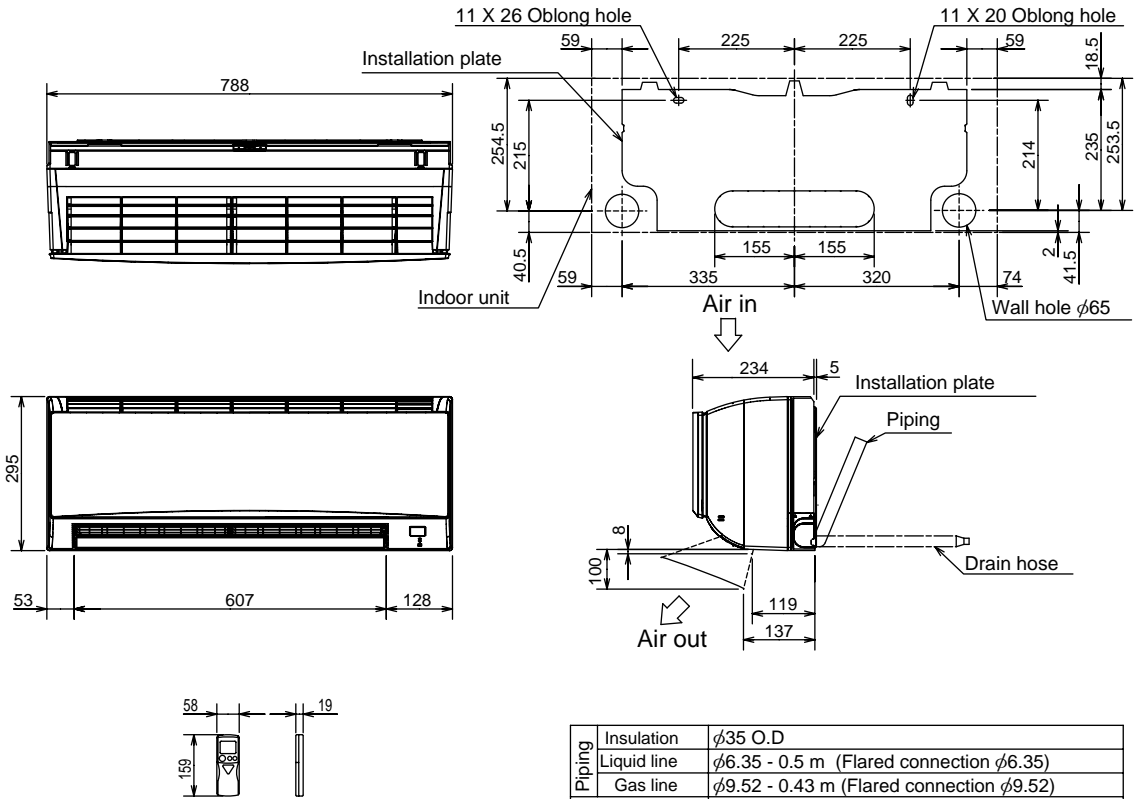

Piping	Insulation	φ35 O.D
	Liquid line	φ6.35 - 0.5 m (Flared connection φ6.35)
	Gas line	φ9.52 - 0.43 m (Flared connection φ9.52)
	Drain hose	Insulation φ28 O.D Connected part φ16 O.D

6

WIRING DIAGRAM

MSZ-GC22VA
MSZ-GC25VA
MSZ-GC35VA

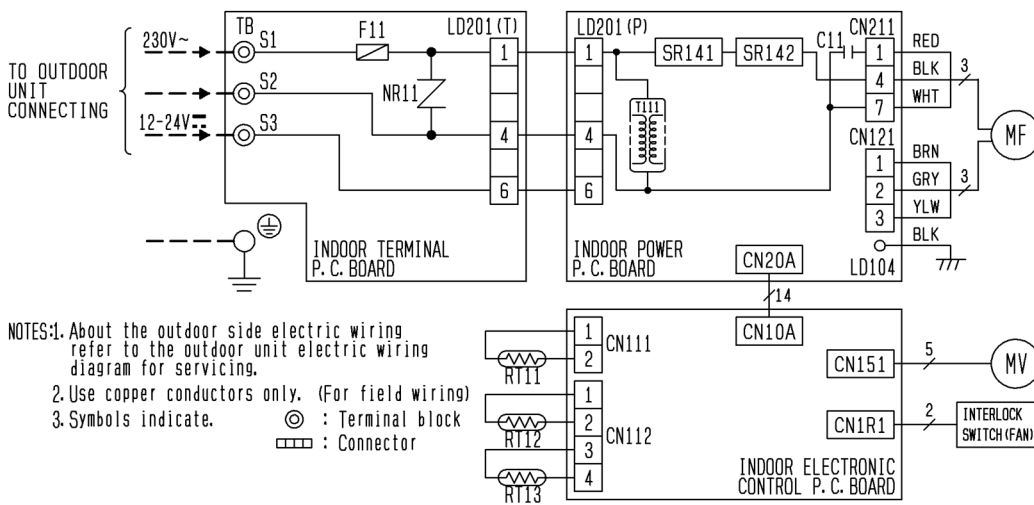

SYMBOL	NAME
C11	FAN MOTOR CAPACITOR
F11	FUSE (T3. 15A/250V)
MF	FAN MOTOR (INNER FUSE)
MV	VANE MOTOR (HORIZONTAL)
NR11	VARISTOR
RT11	ROOM TEMP. THERMISTOR
RT12	COIL TEMP. THERMISTOR (MAIN)
RT13	COIL TEMP. THERMISTOR (SUB)
SR141	SOLID STATE RELAY
SR142	SOLID STATE RELAY
T111	TRANSFORMER
TB	TERMINAL BLOCK

7

REFRIGERANT SYSTEM DIAGRAM

MSZ-GC22VA
MSZ-GC25VA
MSZ-GC35VA

Unit : mm

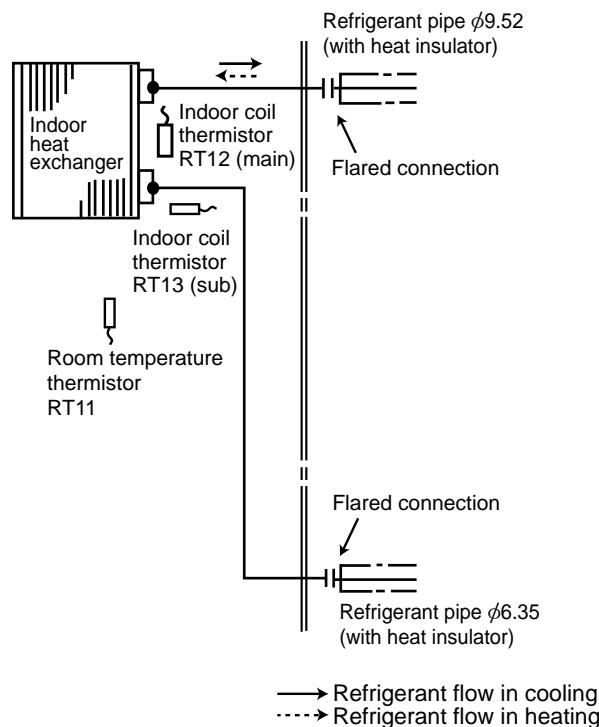

MSZ-GC22VA
MSZ-GC25VA
MSZ-GC35VA

8-1. TIMER SHORT MODE

For service, set time can be shortened by short circuit of JPG and JPS on the electronic control P.C. board.
 The time will be shortened as follows. (Refer to 10-7.)

Set time : 1-minute → 1-second

Set time : 3-minute → 3-second (It takes 3 minutes for the compressor to start operation. However, the starting time is shortened by short circuit of JPG and JPS.)

8-2. P.C. BOARD MODIFICATION FOR INDIVIDUAL OPERATION

A maximum of 4 indoor units with wireless remote controllers can be used in a room.

In this case, to operate each indoor unit individually by each remote controller, P.C. boards of remote controller must be modified according to the number of the indoor unit.

How to modify the remote controller P.C. board

Remove batteries before modification.

The board has a print as shown below :

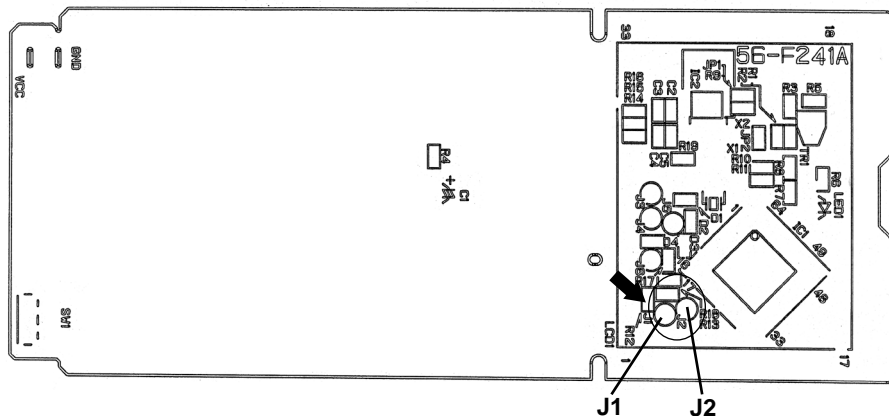

NOTE : For modification, take out the batteries and press the OPERATE/STOP(ON/OFF) button twice or 3 times at first.
 After modification, put back the batteries then press the RESET button.

The P.C. board has the print "J1" and "J2". Solder "J1" and "J2" according to the number of indoor unit as shown in Table 1.
 After modification, press the RESET button.

Table 1

	1 unit operation	2 units operation	3 units operation	4 units operation
No. 1 unit	No modification	Same as at left	Same as at left	Same as at left
No. 2 unit	–	Solder J1	Same as at left	Same as at left
No. 3 unit	–	–	Solder J2	Same as at left
No. 4 unit	–	–	–	Solder both J1 and J2

How to set the remote controller exclusively for particular indoor unit

After you turn the breaker ON, the first remote controller that sends the signal to the indoor unit will be regarded as the remote controller for the indoor unit.

The indoor unit will only accept the signal from the remote controller that has been assigned to the indoor unit once they are set.

The setting will be cancelled if the breaker is turned OFF, or the power supply is shut down.

Please conduct the above setting once again after the power has restored.

8-3. AUTO RESTART FUNCTION

When the indoor unit is controlled with the remote controller, the operation mode, the set temperature, and the fan speed are memorized by the indoor electronic control P.C. board. "AUTO RESTART FUNCTION" automatically starts operation in the same mode just before the shutoff of the main power.

Operation

- ① If the main power has been cut, the operation settings remain.
- ② After the power is restored, the unit restarts automatically according to the memory.
(However, it takes at least 3 minutes for the compressor to start running.)

How to release "AUTO RESTART FUNCTION"

- ① Turn off the main power for the unit.
- ② Solder the jumper wire to JR07 on the indoor electronic control P.C. board. (Refer to 10-7.)

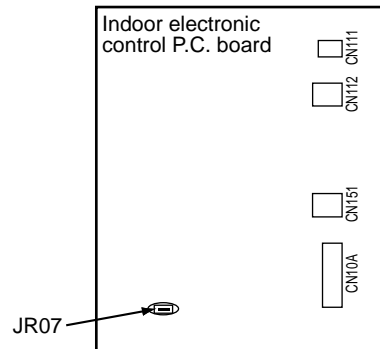

NOTE :

- The operation settings are memorized when 10 seconds have passed after the indoor unit was operated with the remote controller.
- If main power is turned OFF or a power failure occurs while AUTO START/STOP timer is active, the timer setting is cancelled.
- If the unit has been off with the remote controller before power failure, the auto restart function does not work as the power button of the remote controller is off.
- To prevent breaker OFF due to the rush of starting current, systematize other home appliance not to turn ON at the same time.
- When some air conditioners are connected to the same supply system, if they are operated before power failure, the starting current of all the compressors may flow simultaneously at restart. Therefore, the special counter-measures are required to prevent the main voltage-drop or the rush of the starting current by adding to the system that allows the units to start one by one.

**MSZ-GC22VA
MSZ-GC25VA
MSZ-GC35VA**

WIRELESS REMOTE CONTROLLER

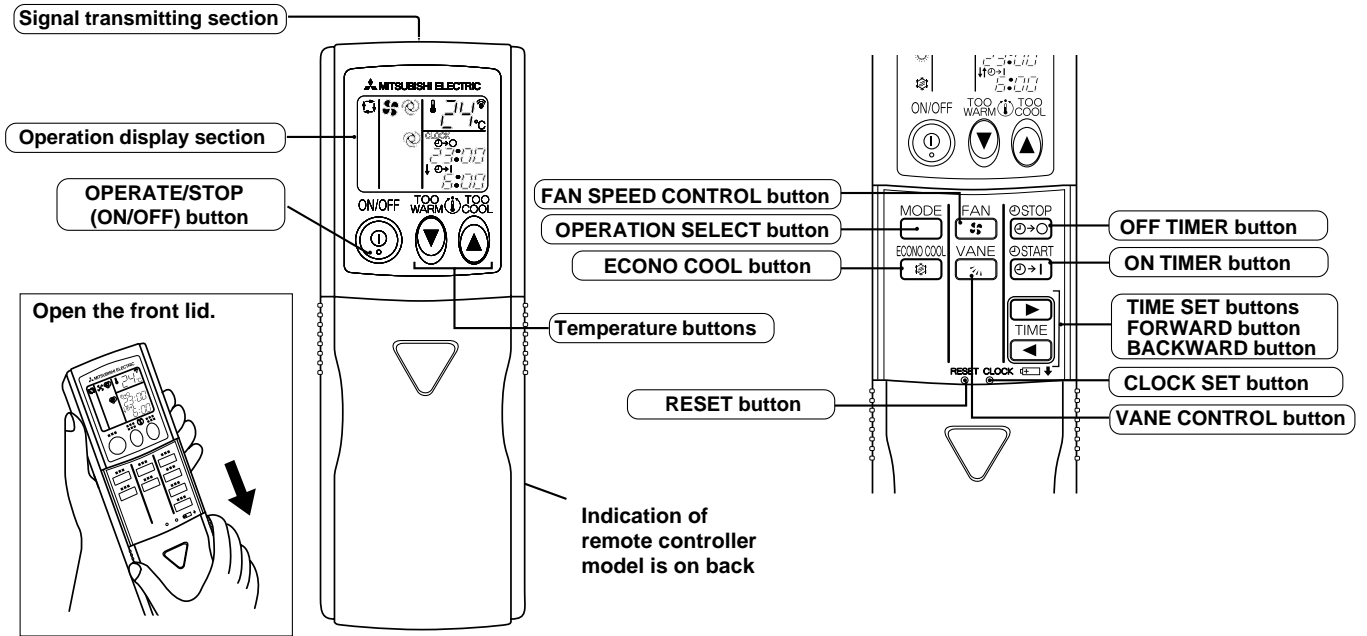

Once the operation mode is set, the same operation mode can be repeated by simply turning OPERATE/STOP (ON/OFF) button ON.

Indoor unit receives the signal with a beep tone.

When the system turns off, 3-minute time delay will operate to protect system from overload and compressor will not restart for 3 minutes.

INDOOR UNIT DISPLAY SECTION

Operation Indicator lamp

The operation indicator at the right side of the indoor unit indicates the operation state.

•The following indication applies regardless of shape of the indicator.

Indication	Operation state	Room temperature
	The unit is operating to reach the set temperature	About 2 °C or more away from set temperature
	The room temperature is approaching the set temperature	About 1 to 2 °C from set temperature
	Standby mode (only during multi system operation)	—

Lighted
Blinking
Not lighted

9-1. COOL (❄) OPERATION

- (1) Press OPERATE/STOP(ON/OFF) button.
OPERATION INDICATOR lamp of the indoor unit turns on with a beep tone.
- (2) Select COOL mode with OPERATION SELECT button.
- (3) Press TEMPERATURE buttons (TOO WARM or TOO COOL button) to select the desired temperature.
The setting range is 16 ~ 31°C.

1. Coil frost prevention

The compressor operational frequency is controlled by the temperature of the indoor heat exchanger to prevent the coil from frosting.

When the temperature of indoor heat exchanger becomes too low, the coil frost prevention mode works.

The indoor fan operates at the set speed and the compressor stops. This mode continues until the temperature of indoor heat exchanger rises.

2. Low outside temperature operation

When the outside temperature is lower, low outside temperature operation starts, and the outdoor fan slows or stops.

9-2. DRY (☁) OPERATION

- (1) Press OPERATE/STOP(ON/OFF) button.
OPERATION INDICATOR lamp of the indoor unit turns on with a beep tone.
- (2) Select DRY mode with OPERATION SELECT button.
- (3) The set temperature is determined from the initial room temperature.

1. Coil frost prevention

Coil frost prevention is as same as COOL mode. (9-1.1.)

2. Low outside temperature operation

Low outside temperature operation is as same as COOL mode. (9-1.2.)

9-3. HEAT (☀) OPERATION

- (1) Press OPERATE/STOP(ON/OFF) button.
OPERATION INDICATOR lamp of the indoor unit turns on with a beep tone.
- (2) Select HEAT mode with OPERATION SELECT button.
- (3) Press TEMPERATURE buttons (TOO WARM or TOO COOL button) to select the desired temperature.
The setting range is 16 ~ 31°C.

1. Cold air prevention control

When the compressor is not operating or is starting, and the temperature of indoor heat exchanger and/or the room temperature is low or when defrosting is being done, the indoor fan will stop or rotate in Very Low speed.

2. High pressure protection

The compressor operational frequency is controlled by the temperature of the indoor heat exchanger to prevent the condensing pressure from increasing excessively.

When the temperature of indoor heat exchanger becomes too high, the high pressure protection works.

The indoor fan operates following the cold air prevention control. This mode continues until the temperature of indoor heat exchanger falls.

3. Defrosting

Defrosting starts when the temperature of outdoor heat exchanger becomes too low.

The compressor stops once, the indoor/outdoor fans stop, the 4-way valve reverses, and the compressor re-starts.

This mode continues until the temperature of outdoor heat exchanger rises or the fixed time passes.

9-4. AUTO CHANGE OVER ... AUTO MODE OPERATION

Once desired temperature is set, unit operation is switched automatically between COOL and HEAT operation.

Mode selection

- (1) Initial mode
When unit starts the operation with AUTO operation from off;
 - If the room temperature is higher than the set temperature, operation starts in COOL mode.
 - If the room temperature is equal to or lower than the set temperature, operation starts in HEAT mode.
- (2) Mode change
COOL mode changes to HEAT mode when about 15 minutes have passed with the room temperature 2 degrees below the set temperature.
HEAT mode changes to COOL mode when about 15 minutes have passed with the room temperature 2 degrees above the set temperature.

NOTE 1

If two or more indoor units are operating in multi system, there might be a case that the indoor unit, which is operating in  (AUTO), cannot change over to the other operating mode (COOL ↔ HEAT) and becomes a state of standby. Refer to **NOTE 2 "FOR MULTI SYSTEM AIR CONDITIONER"**.

NOTE 2
FOR MULTI SYSTEM AIR CONDITIONER
OUTDOOR UNIT : MXZ series

Multi system air conditioner can connect two or more indoor units with one outdoor unit.

- Unit won't operate in case the total capacity of indoor units exceeds the capacity of outdoor units. Do not connect indoor units beyond the outdoor unit capacity.
 Operation indicator lamp flashes as shown in the figure below.
- When you try to operate two or more indoor units with one outdoor unit simultaneously, one for the cooling and the others for heating, the operation mode of the indoor unit that operates earlier is selected. The other indoor units cannot operate, indicating as shown in the figure below. In this case, please set all the indoor units to the same operation mode.

OPERATION INDICATOR

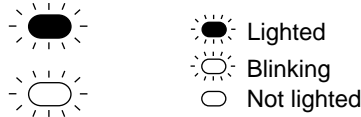

- When indoor unit starts the operation while the defrosting of outdoor unit is being done, it takes a few minutes(max. 10 minutes) to blow out the warm air.
- In the heating operation, though indoor unit that does not operate may get warm or the sound of refrigerant flowing may be heard, they are not malfunction. The reason is that the refrigerant continuously flows into it.

9-5. AUTO VANE OPERATION

1. Horizontal vane

(1) Vane motor drive

These models are equipped with a stepping motor for the horizontal vane. The rotating direction, speed, and angle of the motor are controlled by pulse signals (approx. 12V) transmitted from indoor microprocessor.

(2) The horizontal vane angle and mode change as follows by pressing VANE CONTROL button.

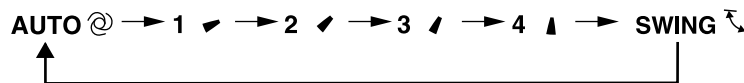

(3) Positioning

To confirm the standard position, the vane moves until it touches the vane stopper. Then the vane is set to the selected angle.

Confirming of standard position is performed in the following cases:

- (a) When the operation starts or finishes (including timer operation).
- (b) When the test run starts.
- (c) When standby mode (only during multi system operation) starts or finishes.

(4) VANE AUTO (⊙) mode

In VANE AUTO mode, the microprocessor automatically determines the vane angle to make the optimum room temperature distribution.

In COOL and DRY operation

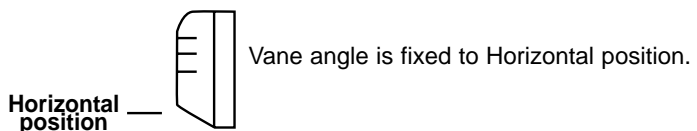

In HEAT operation

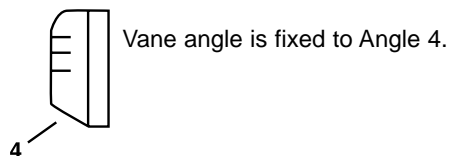

(5) STOP (operation OFF) and ON TIMER standby

In the following cases, the horizontal vane returns to the closed position.

- (a) When OPERATE/STOP (ON/OFF) button is pressed (POWER OFF).
- (b) When the operation is stopped by the emergency operation.
- (c) When ON TIMER is ON standby.

(6) Dew prevention

During COOL or DRY operation with the vane angle at Angle 2 ~ 4 when the compressor cumulative operation time exceeds 1 hour, the vane angle automatically changes to Angle 1 for dew prevention.

(7) SWING () mode



By selecting SWING mode with VANE CONTROL button, the horizontal vane swings vertically.

(8) Cold air prevention in HEAT operation

The horizontal vane position is set to Upward.

NOTE : When 2 or more indoor units are operated with multi outdoor unit, even if any indoor unit turns thermostat off, this control doesn't work in the indoor unit.

(9) To change the air flow direction not to blow directly onto your body.

To change the air flow direction	When to use this function?	COOL/DRY	HEAT
Pressing and holding VANE CONTROL button for 2 seconds or more causes the horizontal vane to reverse and move to horizontal position.  Horizontal position	Use this function if you don't want the air from the indoor unit to blow directly onto your body. <ul style="list-style-type: none"> Depending on the shape of the room, the air may blow directly onto your body. Press VANE CONTROL button again to return the vane to the previously-set position. 	The air conditioner starts the cooling or drying operation approx. 3 minutes after the vane has moved to the horizontal position. <ul style="list-style-type: none"> When VANE CONTROL button is pressed again, the vane returns to the previously-set position and the air conditioner starts the cool or dry operation in approx. 3 minutes. 	The air conditioner starts heating operation approx. 3 minutes after the vane has moved to the horizontal position. <ul style="list-style-type: none"> Sometimes the area around your feet may not warm. To warm the area around the feet, set the horizontal vane to  (AUTO) or the downward-blowing position. When VANE CONTROL button is pressed again, the vane returns to the previously-set position and the air conditioner starts the heat operation in approx. 3 minutes.

NOTE :

- If you make the air flow not to blow directly onto your body by pressing VANE CONTROL button, the compressor stops for 3 minutes even during the operation of the air conditioner.
- The air conditioner operates with Very Low speed until the compressor turns on again.

(10) ECONO COOL () operation (ECONOmical operation)

When ECONO COOL button is pressed in COOL mode, set temperature is automatically set 2°C higher.

Also the horizontal vane swings in various cycle.

SWING operation makes you feel cooler than set temperature. So, even though the set temperature is higher, the air conditioner can keep comfort. As a result, energy can be saved.

ECONO COOL operation is cancelled when ECONO COOL button is pressed once again or VANE CONTROL button is pressed or change to other operation mode.

9-6. TIMER OPERATION

1. How to set the time



- (1) Check that the current time is set correctly.

NOTE : Timer operation will not work without setting the current time. Initially "AM0:00" blinks at the current time display of TIME MONITOR, so set the current time correctly with CLOCK SET button.

How to set the current time

(a) Press the CLOCK set button.

(b) Press the TIME SET buttons ( and ) to set the current time.

- Each time FORWARD button () is pressed, the set time increases by 1minute, and each time BACKWARD button () is pressed, the set time decreases by 1minute.
- Pressing those buttons longer, the set time increases / decreases by 10 minutes.

(c) Press the CLOCK set button.

- (2) Press OPERATE/STOP (ON/OFF) button to start the air conditioner.

- (3) Set the time of timer.

ON timer setting



(a) Press ON TIMER button() during operation.

(b) Set the time of the timer using TIME SET buttons ( and ). *

OFF timer setting

(a) Press OFF TIMER button () during operation.

(b) Set the time of the timer using TIME SET buttons ( and ). *

* Each time FORWARD button () is pressed, the set time increases by 10 minutes; each time BACKWARD button () is pressed, the set time decreases by 10 minutes.

2. To release the timer

To release ON timer, press ON TIMER button ().

To release OFF timer, press OFF TIMER button ().

TIMER is cancelled and the display of set time disappears.

PROGRAM TIMER

- OFF timer and ON timer can be used in combination. The timer of the set time that is reached first will operate first.
- “↑” and “↓” display shows the order of OFF timer and ON timer operation.

(Example 1) The current time is 8:00 PM.

The unit turns off at 11:00 PM, and on at 6:00 AM.

(Example 2) The current time is 11:00 AM.

The unit turns on at 5:00 PM, and off at 9:00 PM.

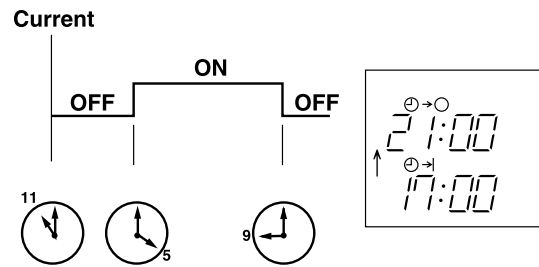
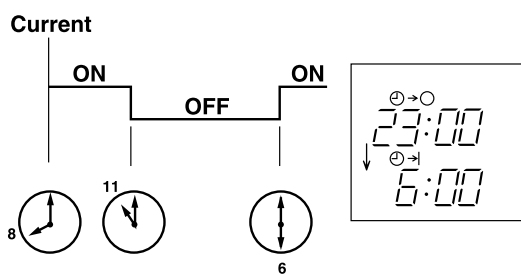

NOTE : If the main power is turned off or a power failure occurs while ON/OFF timer is active, the timer setting is cancelled. As these models are equipped with an auto restart function, the air conditioner starts operating with timer cancelled when power is restored.

9-7. EMERGENCY/TEST OPERATION

In case of test run operation or emergency operation, use EMERGENCY OPERATION switch on the right side of the indoor unit. Emergency operation is available when the remote controller is missing, has failed or the batteries of the remote controller run down. The unit will start and OPERATION INDICATOR lamp will light.

The first 30 minutes of operation is the test run operation. This operation is for servicing. The indoor fan runs at High speed and the system is in continuous operation (The thermostat does not work).

After 30 minutes of test run operation, the system shifts to EMERGENCY COOL / HEAT MODE with a set temperature of 24°C. The fan speed shifts to Med..

In the test run or emergency operation, the horizontal vane operates in VANE AUTO (@) mode.

Emergency operation continues until EMERGENCY OPERATION switch is pressed once or twice or the unit receives any signal from the remote controller. In case of latter, normal operation will start.

NOTE : Do not press EMERGENCY OPERATION switch during normal operation.







EMERGENCY OPERATION switch (E.O. SW)

Operation mode	COOL	HEAT
Set temperature	24°C	24°C
Fan speed	Medium	Medium
Horizontal vane	Auto	Auto

The operation mode is indicated by the Operation Indicator lamp on the indoor unit as following

Operation Indicator lamp

EMERGENCY COOL		 Lighted  Not lighted
EMERGENCY HEAT		
STOP		

MSZ-GC22VA MSZ-GC25VA MSZ-GC35VA

10-1. Cautions on troubleshooting

1. Before troubleshooting, check the following:

- 1) Check the power supply voltage.
- 2) Check the indoor/outdoor connecting wire for mis-wiring.

2. Take care of the following during servicing

- 1) Before servicing the air conditioner, be sure to turn OFF the main unit first with the remote controller, and then after confirming the horizontal vane is closed, turn OFF the breaker and / or disconnect the power plug.
- 2) Be sure to turn OFF the power supply before removing the front panel, the cabinet, the top panel, and the P.C. board.
- 3) When removing the P.C. board, hold the edge of the board with care NOT to apply stress on the components.
- 4) When connecting or disconnecting the connectors, hold the housing of the connector. DO NOT pull the lead wires.

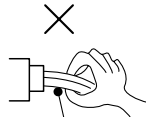

Lead wiring

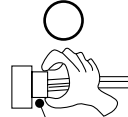

Housing point

3. Troubleshooting procedure

- 1) First, check if the OPERATION INDICATOR lamp on the indoor unit is flashing on and off to indicate an abnormality. To make sure, check how many times the abnormality indication is flashing on and off before starting service work.
- 2) Before servicing, check that the connector and terminal are connected properly.
- 3) If the P.C. board is supposed to be defective, check the copper foil pattern for disconnection and the components for bursting and discoloration.
- 4) When troubleshooting, refer to 10-2., 10-3. and 10-4.

4. How to replace batteries

Weak batteries may cause the remote controller malfunction.

In this case, replace the batteries to operate the remote controller normally.

- ① Remove the front lid and insert batteries. Then reattach the front lid.

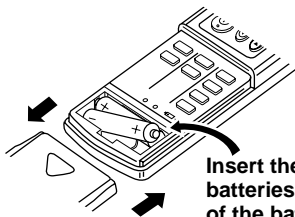

Insert the negative pole of the batteries first. Check if the polarity of the batteries is correct.

- ② Press RESET button with tip end of ball point pen or the like, and then use the remote controller.

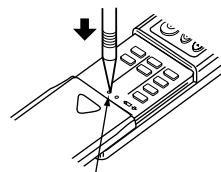

RESET button

NOTE : 1. If RESET button is not pressed, the remote controller may not operate correctly.

2. This remote controller has a circuit to automatically reset the microcomputer when batteries are replaced.

This function is equipped to prevent the microcomputer from malfunctioning due to the voltage drop caused by the battery replacement.

5. How to install the horizontal vane

If horizontal vane is not installed correctly, all of the operation indicator lamps will blink.

In this case, install the horizontal vane correctly by following the procedures ① to ②.

NOTE : Before installation of the horizontal vane, turn OFF the power supply.

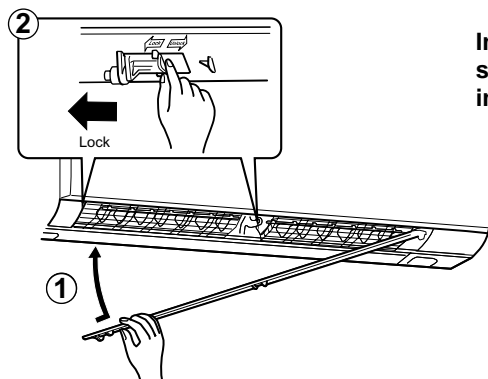

In procedure ② lock the stoppers until they click into place.

10-2. Failure mode recall function

Outline of the function

This air conditioner can memorize the abnormal condition which has occurred once.

Even though LED indication listed on the troubleshooting check table (10-4.) disappears, the memorized failure details can be recalled.

This mode is very useful when the unit needs to be repaired for the abnormality which doesn't recur.

1. Flow chart of failure mode recall function for the indoor/outdoor unit

Operational procedure

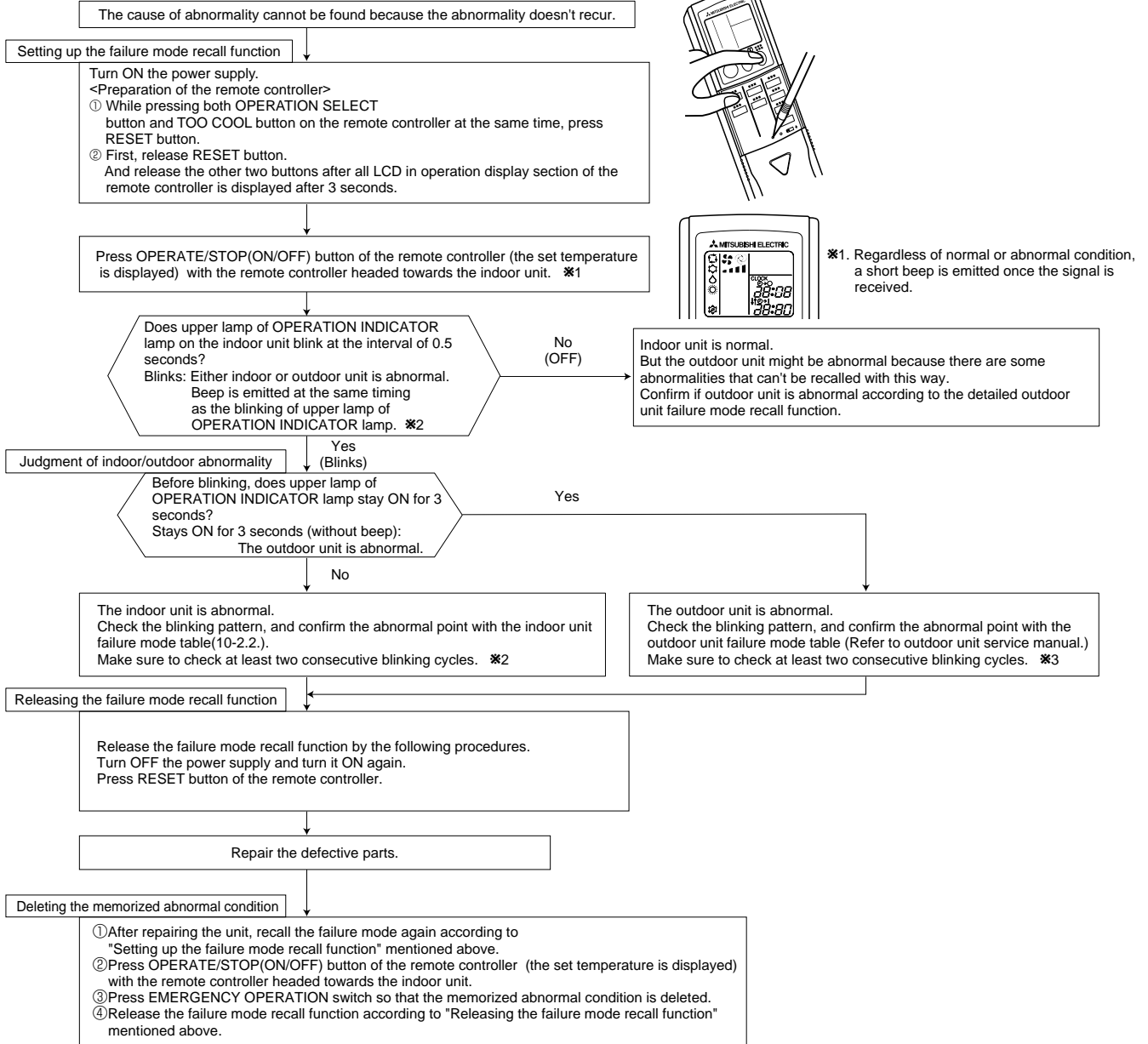

NOTE: 1.Make sure to release the failure mode recall function once it's set up, otherwise the unit cannot operate properly.

2.If the abnormal condition is not deleted from the memory, the last abnormal condition is kept memorized.

※2. Blinking pattern when the indoor unit is abnormal:

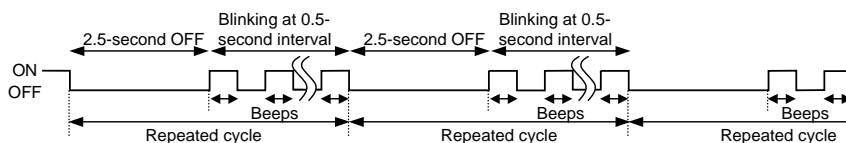

※3. Blinking pattern when the outdoor unit is abnormal:

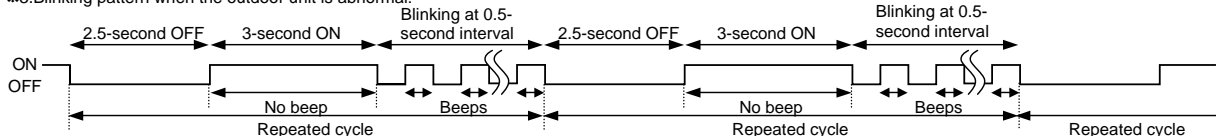



2. Indoor unit failure mode table

Upper lamp of OPERATION INDICATOR lamp	Abnormal point (Failure mode)	Condition	Correspondence
Not lighted	Normal	—	—
1-time flash every 0.5-second	Room temperature thermistor	The room temperature thermistor short or open circuit is detected every 8 seconds during operation.	Refer to the characteristics of the room temperature thermistor (10-7.).
2-time flash 2.5-second OFF	Indoor coil thermistor	The indoor coil thermistor short or open circuit is detected every 8 seconds during operation.	Refer to the characteristics of the main indoor coil thermistor, the sub indoor coil thermistor (10-7.).
3-time flash 2.5-second OFF	Serial signal	The serial signal from outdoor unit is not received for 6 minutes.	Refer to 10-6.③ "How to check mis-wiring and serial signal error".
11-time flash 2.5-second OFF	Indoor fan motor	The rotational frequency feedback signal is not sent out for 12-seconds after indoor fan motor is operated.	Refer to 10-6.④ "Check of indoor fan motor".
12-time flash 2.5-second OFF	Indoor control system	It cannot properly read data in the nonvolatile memory of the indoor electronic control P.C. board.	Replace the indoor electronic control P.C. board.

NOTE : Blinking patterns of this mode differ from the ones of Troubleshooting check table (10-4.).

10-3. Instruction of troubleshooting

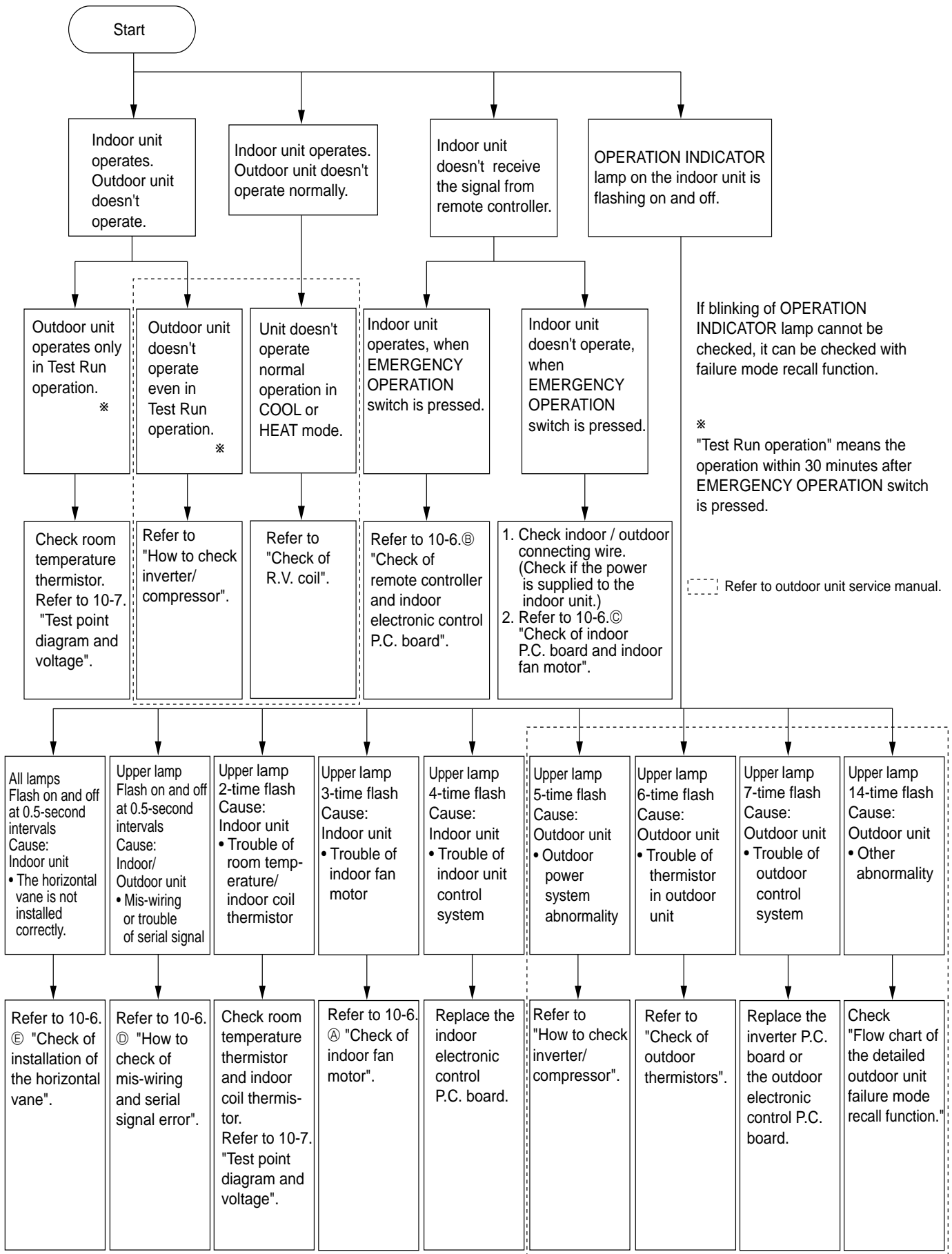

10-4. Troubleshooting check table

Before taking measures, make sure that the symptom reappears for accurate troubleshooting. When the indoor unit has started operation and the following detection method has detected an abnormality (the first detection after the power ON), the indoor electronic control P.C. board turns OFF the indoor fan motor with OPERATION INDICATOR lamp flashing.

OPERATION INDICATOR



Lighted



Blinking



Not lighted

No.	Abnormal point	Operation indicator lamp	Symptom	Condition	Correspondence
1	Mis-Wiring or serial signal	Upper lamp flashes. 0.5-second ON ●○○○○●○○ 0.5-second OFF	Indoor unit and outdoor unit do not operate.	The serial signal from the outdoor unit is not received for 6 minutes.	• Refer to 10-6.⑥ "How to check mis-wiring and serial signal error".
2	Indoor coil thermistor	Upper lamp flashes. 2-time flash ●●○○○○○○○○○○○○○○○○		The indoor coil or the room temperature thermistor is short or open circuit.	• Refer to 10-7.the characteristics of indoor coil thermistor, and the room temperature thermistor.
	Room temperature thermistor	2.5-second OFF			
3	Indoor fan motor	Upper lamp flashes. 3-time flash ●●●○○○○○○○○○○○○○○○○		The rotational frequency feedback signal is not emitted during the indoor fan operation.	• Refer to 10-6.⑦ "Check of indoor fan motor".
4	Indoor control system	Upper lamp flashes. 4-time flash ●●●●○○○○○○○○○○○○○○○○		It cannot properly read data in the nonvolatile memory of the indoor electronic control P.C. board.	• Replace the indoor electronic control P.C. board.
5	Outdoor power system	Upper lamp flashes. 5-time flash ●●●●○○○○○○○○○○○○○○○○		It consecutively occurs 3 times that the compressor stops for overcurrent protection or start-up failure protection within 1 minute after start-up.	• Refer to "How to check of inverter/compressor". Refer to outdoor unit service manual. • Check the stop valve.
6	Outdoor thermistors	Upper lamp flashes. 6-time flash ●●●●○○○○○○○○○○○○○○○○		The outdoor thermistors short or open circuit during the compressor operation.	• Refer to "Check of outdoor thermistor". Refer to outdoor unit service manual.
7	Outdoor control system	Upper lamp flashes. 7-time flash ●●●●○○○○○○○○○○○○○○○○		It cannot properly read data in the nonvolatile memory of the inverter P.C. board or the outdoor electronic control P.C. board.	• Replace the inverter P.C. board or the outdoor electronic control P.C. board. Refer to outdoor unit service manual.
8	Other abnormality	Upper lamp flashes. 14-time flash ●●●●○○○○○○○○○○○○○○○○		An abnormality other than above mentioned is detected.	• Check the stop valve. • Confirm the abnormality in detail using the failure mode recall function for outdoor unit.
9	Outdoor control system	Upper lamp lights up ●	Outdoor unit does not operate.	It cannot properly read data in the nonvolatile memory of the inverter P.C. board or the outdoor electronic control P.C. board.	• Check the blinking pattern of the LED on the inverter P.C. board or the outdoor electronic control P.C. board.

OPERATION INDICATOR

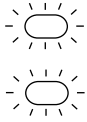

No.	Abnormal point	Operation indicator lamp	Symptom	Condition	Correspondence
1	Attachment of the horizontal vane	All lamps flash at the same time. 0.5-second ON  0.5-second OFF	Indoor unit and outdoor unit do not operate.	The electricity is not conducted to the interlock switch (Fan) of the horizontal vane.	• Refer to 10-6.⑥ "Check of installation of the horizontal vane".

OPERATION INDICATOR

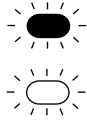

No.	Abnormal point	Operation indicator lamp	Symptom	Condition	Correspondence
1	MXZ type Operation mode setting	Upper lamp lights and lower lamp flashes.  2.5-second OFF	Outdoor unit operates but indoor unit does not operate.	The operation mode of the each indoor unit is differently set to COOL(includes DRY) and HEAT at the same time, the operation mode of the indoor unit that has operated at first has the priority.	• Unify the operation mode. Refer to outdoor unit service manual.

10-5. Trouble criterion of main parts

MSZ-GC22VA MSZ-GC25VA MSZ-GC35VA

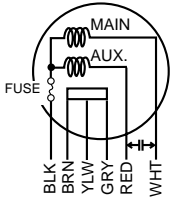
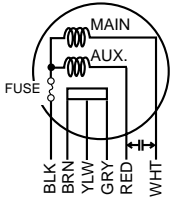
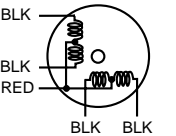
Part name	Check method and criterion	Figure											
Room temperature thermistor (RT11)	Measure the resistance with a tester.												
Indoor coil thermistor (RT12, RT13)	Refer to 10-7."Test point diagram and voltage", "2.Indoor electronic control P.C. board", the chart of thermistor.												
Indoor fan motor (MF) INNER FUSE BA : 135±3°C CUT OFF CA : 140±2°C CUT OFF	<p>Motor part</p> <p>Measure the resistance between the terminals with a tester. (Part temperature 10°C ~ 30°C)</p> <table border="1" style="width: 100%;"> <thead> <tr> <th rowspan="2">Color of lead wire</th> <th colspan="2">Normal</th> </tr> <tr> <th>RC4V18-BA</th> <th>RC4V18-CA</th> </tr> </thead> <tbody> <tr> <td>WHT – BLK</td> <td>273 Ω ~ 296 Ω</td> <td>308 Ω ~ 334 Ω</td> </tr> <tr> <td>BLK – RED</td> <td>295 Ω ~ 320 Ω</td> <td>295 Ω ~ 320 Ω</td> </tr> </tbody> </table>	Color of lead wire	Normal		RC4V18-BA	RC4V18-CA	WHT – BLK	273 Ω ~ 296 Ω	308 Ω ~ 334 Ω	BLK – RED	295 Ω ~ 320 Ω	295 Ω ~ 320 Ω	
	Color of lead wire		Normal										
RC4V18-BA		RC4V18-CA											
WHT – BLK	273 Ω ~ 296 Ω	308 Ω ~ 334 Ω											
BLK – RED	295 Ω ~ 320 Ω	295 Ω ~ 320 Ω											
<p>Sensor part</p> <p>Measure the voltage power ON.</p> <table border="1" style="width: 100%;"> <thead> <tr> <th>Color of lead wire</th> <th>Normal</th> </tr> </thead> <tbody> <tr> <td>BRN – YLW</td> <td>4.5 ~ 5.5V</td> </tr> <tr> <td>BRN – GRY</td> <td>(When fan revolved one time) 0V→5V→0V (Approx.)</td> </tr> </tbody> </table>	Color of lead wire	Normal	BRN – YLW	4.5 ~ 5.5V	BRN – GRY	(When fan revolved one time) 0V→5V→0V (Approx.)							
Color of lead wire	Normal												
BRN – YLW	4.5 ~ 5.5V												
BRN – GRY	(When fan revolved one time) 0V→5V→0V (Approx.)												
Vane motor (MV)	<p>Measure the resistance between the terminals with a tester. (Part temperature 10°C ~ 30°C)</p> <table border="1" style="width: 100%;"> <thead> <tr> <th>Color of the lead wire</th> <th>Normal</th> </tr> </thead> <tbody> <tr> <td>RED-BLK</td> <td>235 Ω ~ 255 Ω</td> </tr> </tbody> </table>	Color of the lead wire	Normal	RED-BLK	235 Ω ~ 255 Ω								
Color of the lead wire	Normal												
RED-BLK	235 Ω ~ 255 Ω												

10-6. Troubleshooting flow

When OPERATION INDICATOR lamp flashes 3-time. Indoor fan does not operate.

Ⓐ Check of indoor fan motor

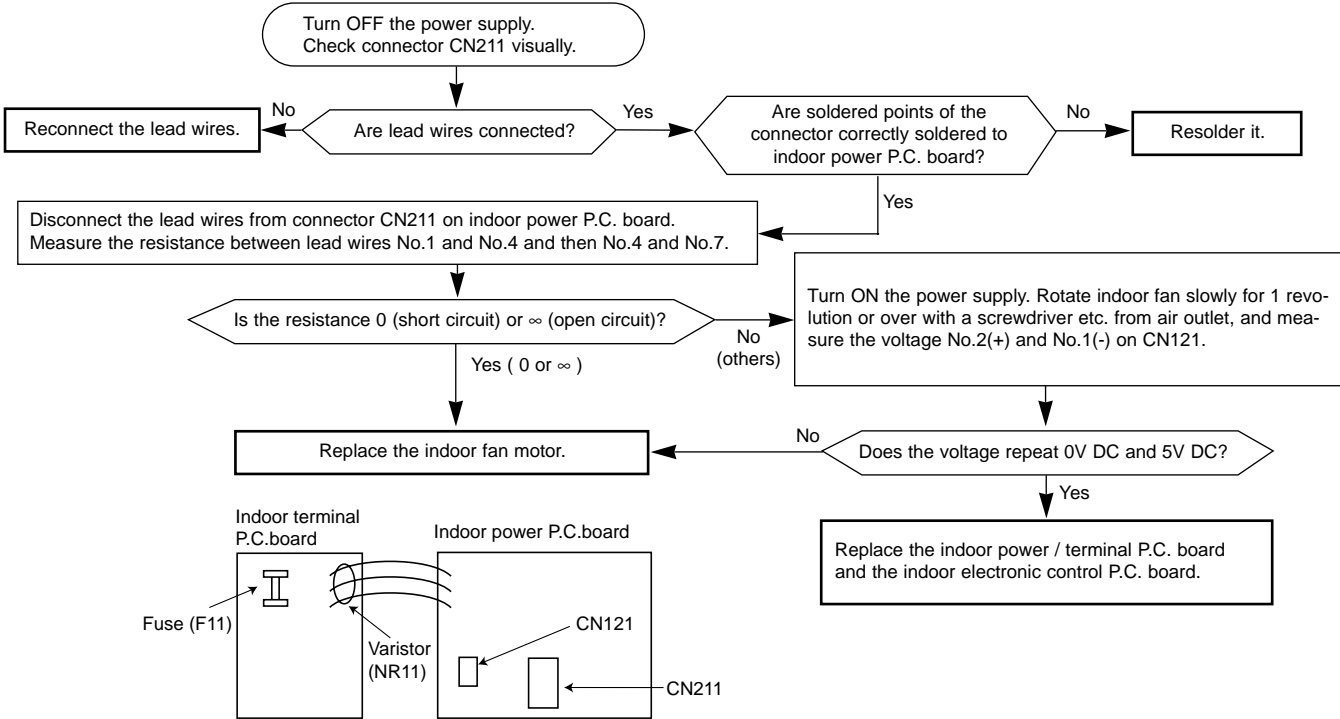

Indoor unit operates by pressing EMERGENCY OPERATION switch, but does not operate with the remote controller.

Ⓑ Check of remote controller and indoor electronic control P.C. board

*Check if the remote controller is exclusive for this air conditioner.

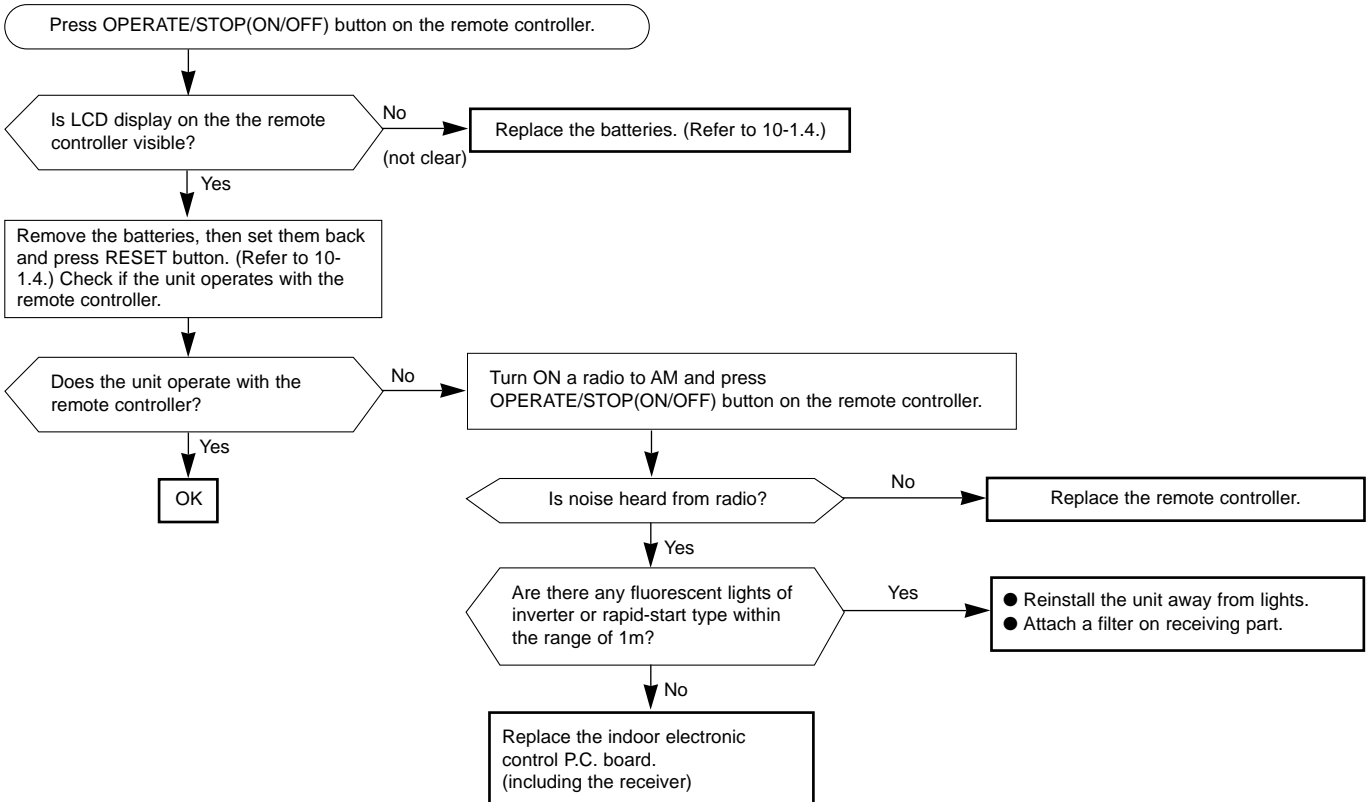

The unit does not operate with the remote controller.
 Also, OPERATION INDICATOR lamp does not light up by pressing EMERGENCY OPERATION switch.

© Check of indoor P.C. board and indoor fan motor

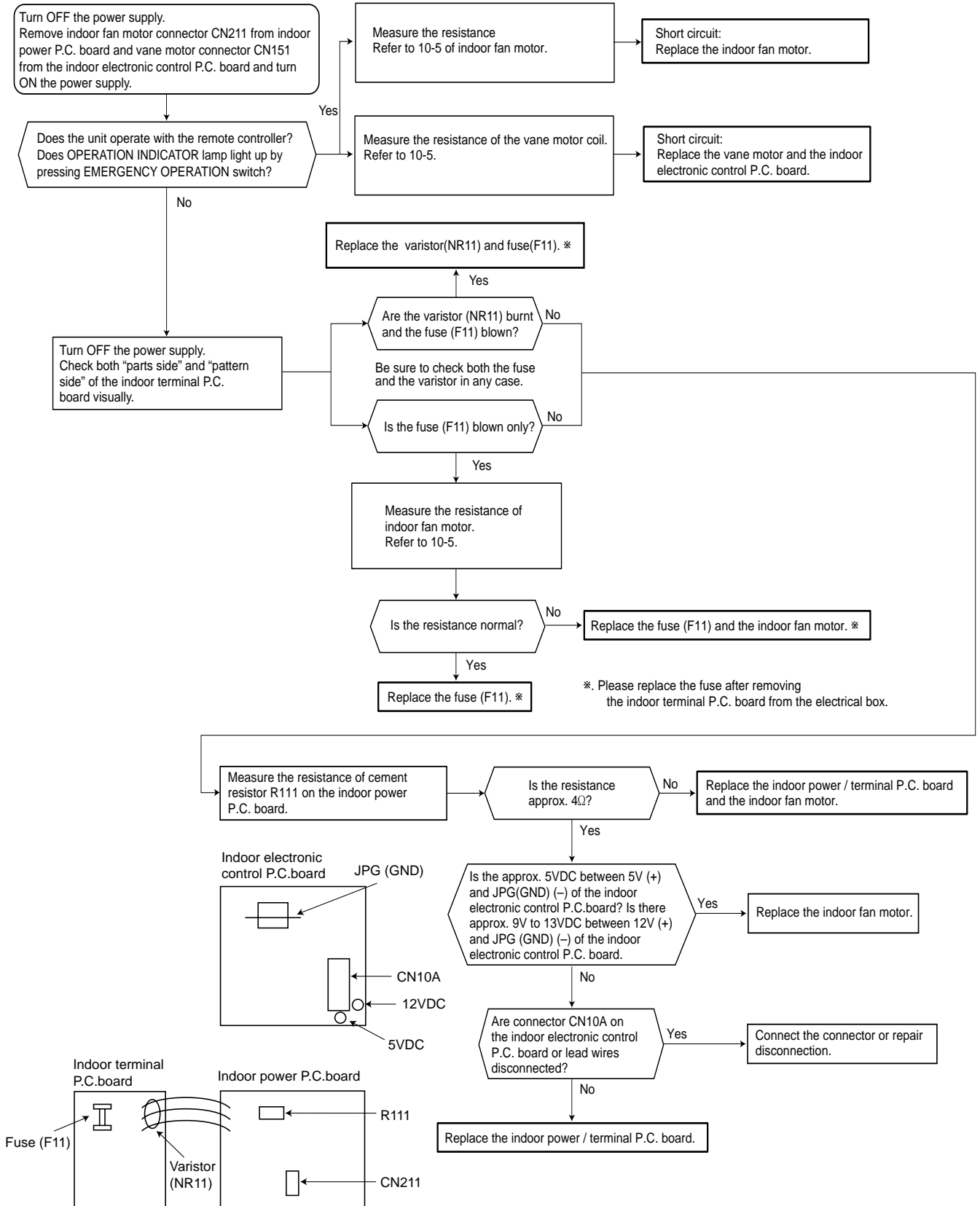

- When unit cannot operate neither by the remote controller nor by EMERGENCY OPERATION switch. Indoor unit does not operate.
- When OPERATION INDICATOR lamp flashes ON and OFF every 0.5-seconds. Outdoor unit does not operate.

D How to check mis-wiring and serial signal error

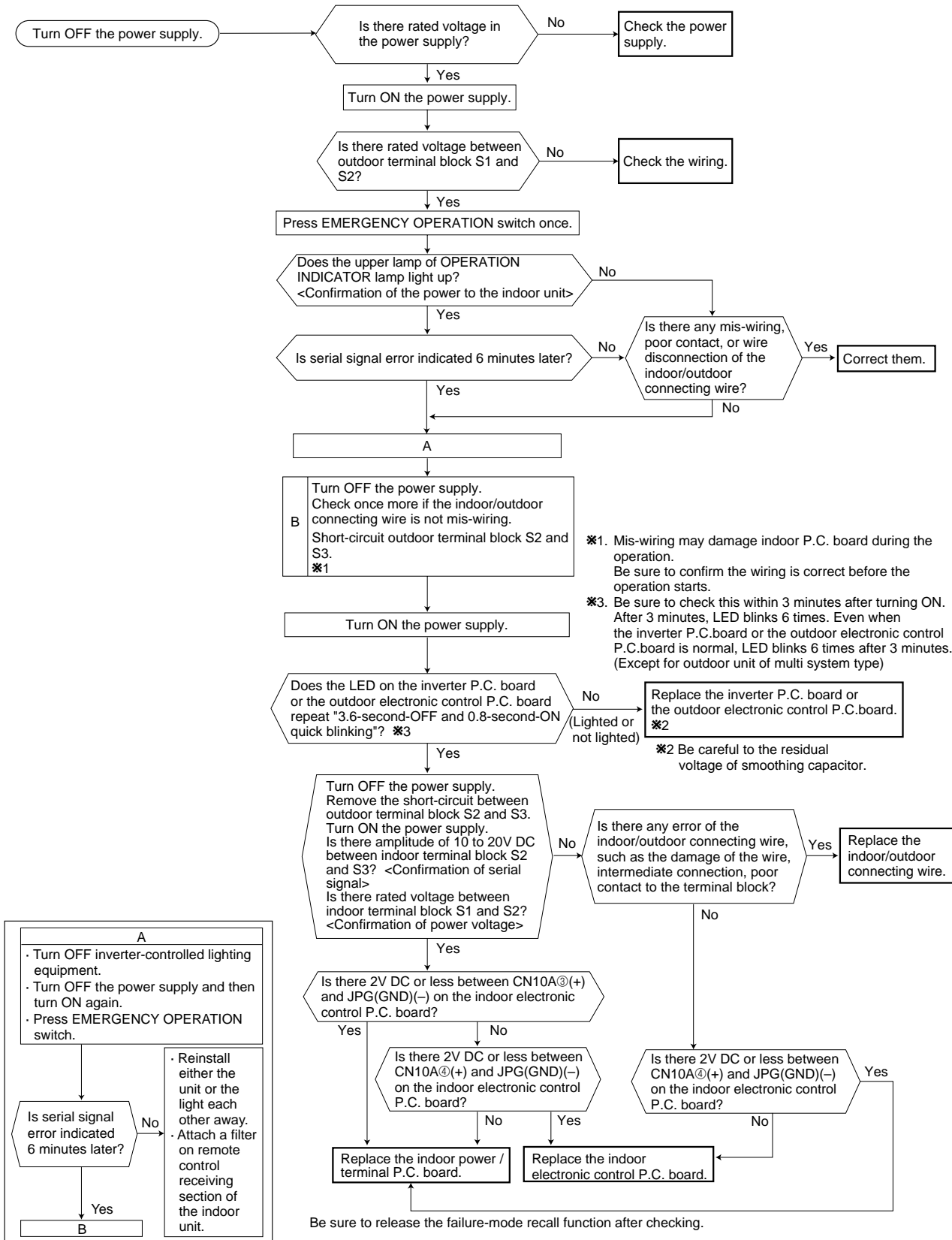

When All lamps flash ON and OFF every 0.5-second.
Indoor unit and outdoor unit do not operate.

E Check of installation of the horizontal vane

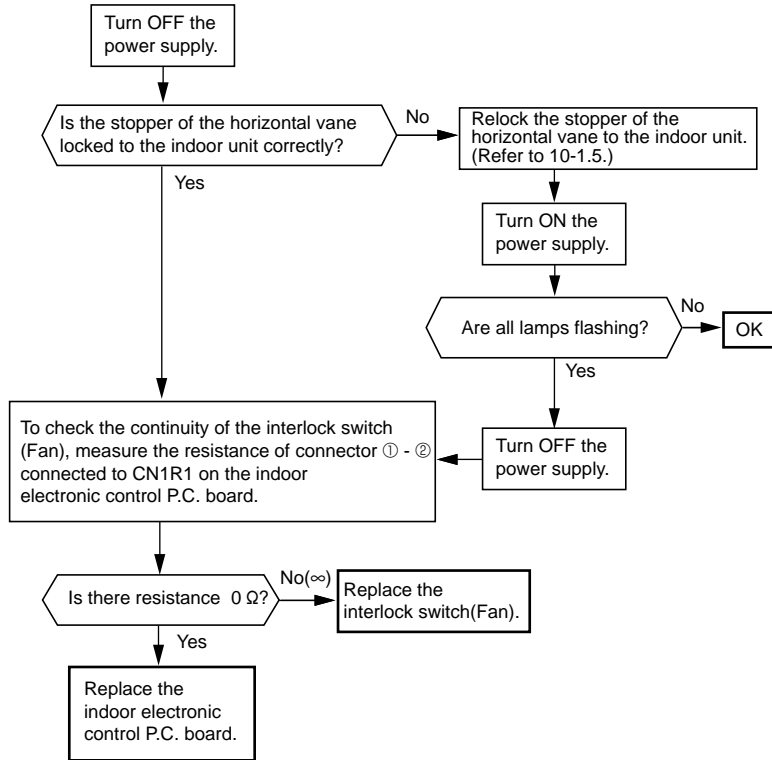

F Electromagnetic noise enters into TV sets or radios

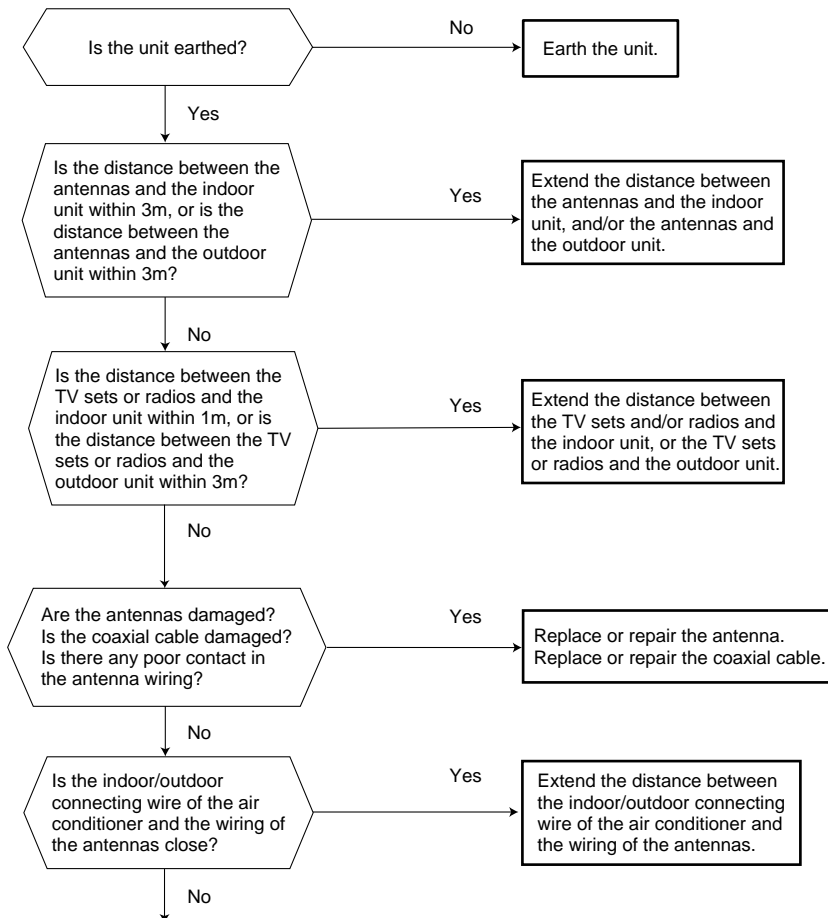

Even if all of the above conditions are fulfilled, the electromagnetic noise may enter, depending on the electric field strength or the installation condition (combination of specific conditions such as antennas or wiring).
 Check the followings before asking for service.

- 1.Devices affected by the electromagnetic noise
 TV sets, radios (FM/AM broadcast, shortwave)
- 2.Channel, frequency, broadcast station affected by the electromagnetic noise
- 3.Channel, frequency, broadcast station unaffected by the electromagnetic noise
- 4.Layout of ;
 indoor/outdoor unit of the air conditioner, indoor/outdoor wiring, grounding wire, antennas, wiring from antennas, receiver
- 5.Electric field intensity of the broadcast station affected by the electromagnetic noise
- 6.Presence or absence of amplifier such as booster
- 7.Operation condition of air conditioner when the electromagnetic noise enters in.
 - 1)Turn OFF the power supply once, and then turn ON the power supply. In this situation, check for the electromagnetic noise.
 - 2)Within 3 minutes after turning ON the power supply, press OPERATE/STOP (ON/OFF) button on the remote controller for power ON, and check for the electromagnetic noise.
 - 3)After a short time (3 minutes later after turning ON), the outdoor unit starts running. During operation, check for the electromagnetic noise.
 - 4)Press OPERATE/STOP (ON/OFF) button on the remote controller for power OFF, when the outdoor unit stops but the indoor/outdoor communication still runs on. In this situation, check for the electromagnetic noise.

After checking the above, consult the service representative.

10-7. Test point diagram and voltage

MSZ-GC22VA MSZ-GC25VA MSZ-GC35VA

1. Indoor power P.C. board, Indoor terminal P.C. board

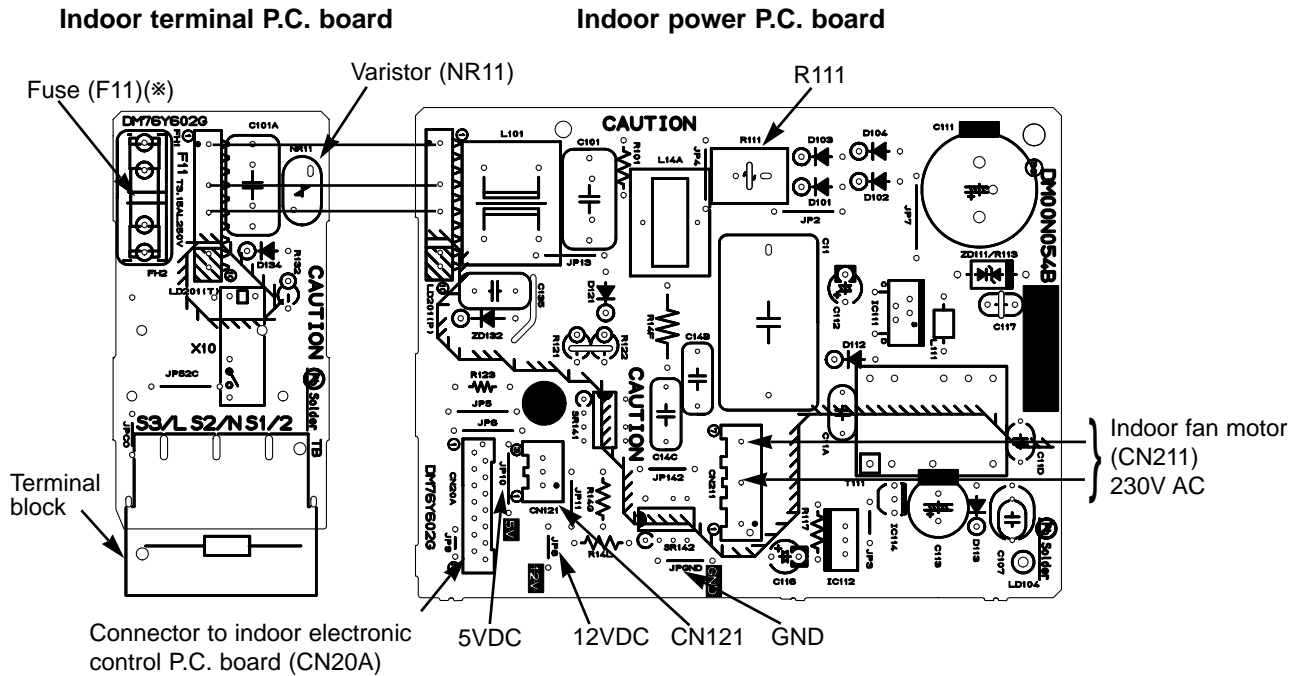

※ Please replace the fuse after removing the indoor terminal P.C. board from the electrical box.

2. Indoor electronic control P.C. board

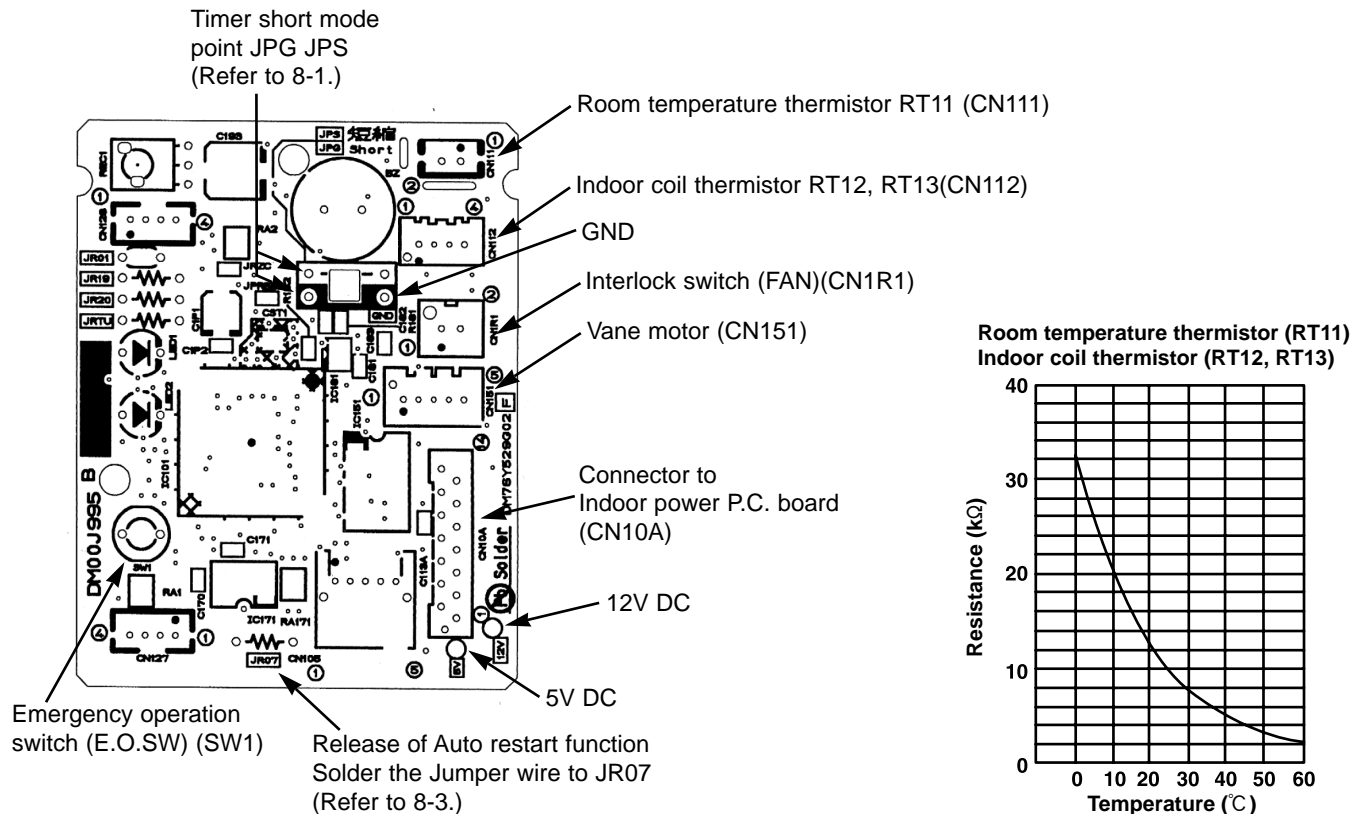

<"Terminal with locking mechanism" Detaching points>

The terminal which has the locking mechanism can be detached as shown below.
There are two types (Refer to (1) and (2)) of the terminal with locking mechanism.
The terminal without locking mechanism can be detached by pulling it out.
Check the shape of the terminal before detaching.

(1) Slide the sleeve and check if there is a locking lever or not.

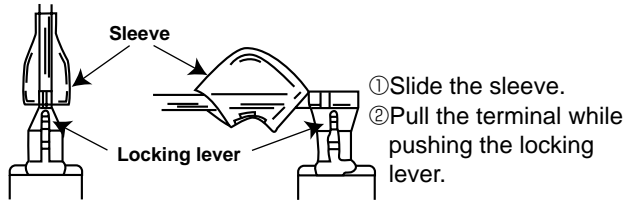

(2) The terminal with this connector has the locking mechanism.

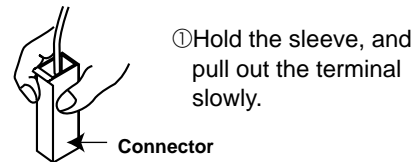
**MSZ-GC22VA MSZ-GC25VA MSZ-GC35VA**

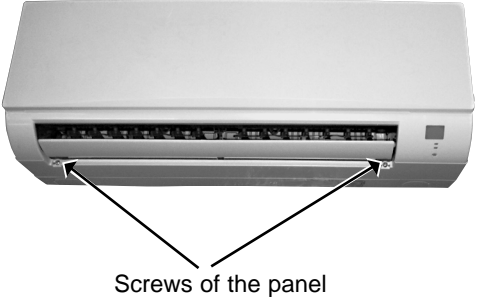
OPERATING PROCEDURE	PHOTOS
<p>1. Removing the panel</p> <p>(1) Remove the screw caps of the panel. Remove the screws.</p> <p>(2) Hold the lower ends part of the panel and pull it slightly toward you, and then remove the panel by pushing it upward.</p>	<p>Photo 1</p> 

OPERATING PROCEDURE

2. Removing the indoor electronic control P.C. board and the room temperature thermistor

- (1) Turn the breaker OFF.
- (2) Remove the panel (Refer to 1) and the corner box.
- (3) Open the indoor electronic control P.C. board holder (to right side), and disconnect connectors of the indoor coil thermistor (CN112), vane motor (CN151), interlock switch (CN1R1) and connector (CN10A) to the indoor power P.C. board on the indoor electronic control P.C. board.
- (4) Unhook the catches of the indoor electronic control P.C. board holder from the nozzle and the electrical box (right side).
- (5) Remove the room temperature thermistor from the hook of the indoor electronic control P.C. board holder.
- (6) Open the back side of the indoor electronic control P.C. board holder, and remove the indoor electronic control P.C. board.
- (7) Remove the room temperature thermistor from the indoor electronic control P.C. board.

3. Remove the indoor power P.C. board, the indoor terminal P.C. board, and the electrical box

- (1) Turn the breaker OFF.
- (2) Remove the panel (Refer to 1) and the corner box.
- (3) Remove the screw of V.A. clamp, and then the indoor/outdoor connecting wire.
- (4) Remove the earth wire connected to the indoor heat exchanger from the electrical box.
- (5) Unhook first the lower, then the upper catches of the electrical box, and pull out the electrical box.
- (6) Remove the screw of the electrical cover and remove the electrical cover.
- (7) Disconnect all the connectors on the indoor power P.C. board and unhook all lead wires.
- (8) Remove the screw of terminal block on the indoor terminal P.C. board.
- (9) Remove the indoor power P.C. board and the indoor terminal P.C. board.

PHOTOS

Photo 2

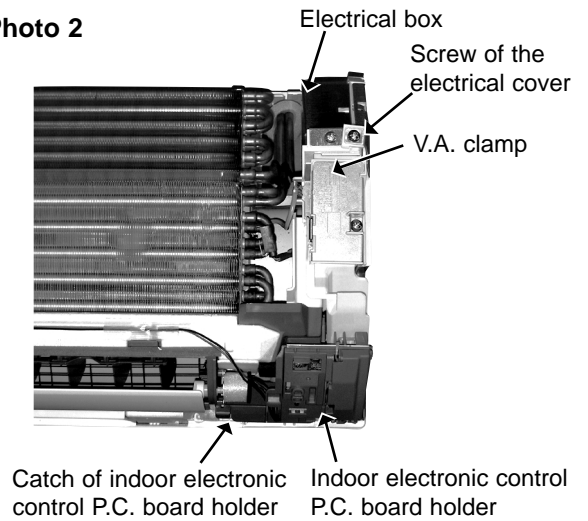
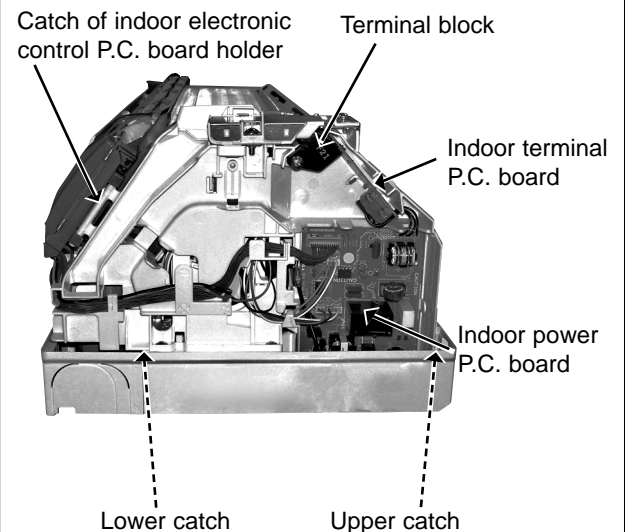

Photo 3



OPERATING PROCEDURE

PHOTOS

4. Removing the vane motor

- (1) Turn the breaker OFF.
- (2) Remove the panel (Refer to 1) and the corner box.
- (3) Remove the indoor electronic control P.C. board holder(Refer to 2).
- (4) Remove the screws of vane motor and remove the vane motor.
- (5) Disconnect the connector from vane motor.

Photo 4

Screws of the vane motor

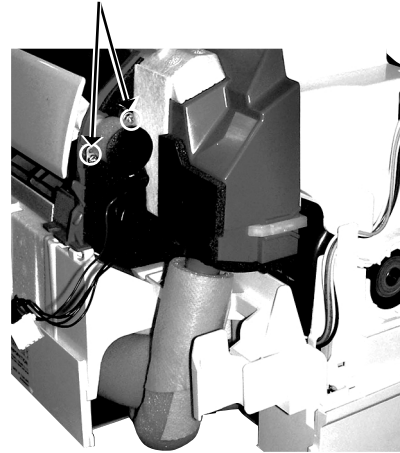

5. Removing the indoor fan motor, the indoor coil thermistor, and the line flow fan

- (1) Remove the panel (Refer to 1) and the corner box.
- (2) Remove the indoor electronic control P.C. board holder (Refer to 2) and the electrical box (Refer to 3) .
- (3) Remove the drain hose from the nozzle assembly, and remove the nozzle assembly.
- (4) Loosen the screw fixing the line flow fan.
- (5) Remove the screws fixing the motor bed. Lift the right side of motor bed a little, and pull right to remove the fan motor together with motor band/bed.
- (6) Remove the indoor coil thermistor from the heat exchanger
- (※) Install the indoor coil thermistor in its former position when assembling it.(Refer to Photo 7)
- (7) Remove the screws fixing the left side of the heat exchanger.
- (8) Lift the left side of the heat exchanger, and pull out the line flow fan to the lower-left.

Photo 5

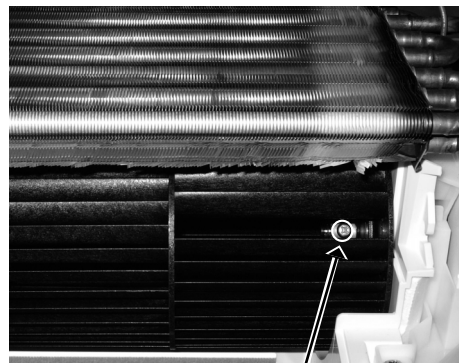

Screws of the line flow fan

Photo 7

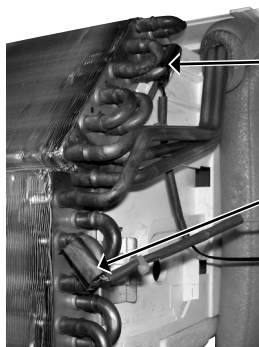

Indoor coil thermistor(main)
RT12

Indoor coil thermistor(sub)
RT13

Photo 6

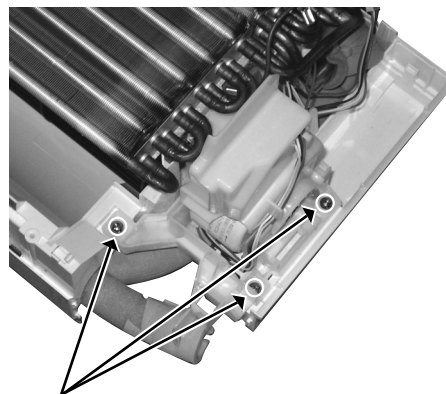

Screws of the motor bed

 **MITSUBISHI ELECTRIC CORPORATION**

HEAD OFFICE: TOKYO BLDG., 2-7-3, MARUNOUCHI, CHIYODA-KU, TOKYO 100-8310, JAPAN

© Copyright 2006 MITSUBISHI ELECTRIC ENGINEERING CO.,LTD
Distributed in Aug. 2007. No. OBH468 REVISED EDITION-B 6
Distributed in Feb. 2007. No. OBH468 REVISED EDITION-A 6
Distributed in Dec. 2006. No. OBH468 6
Made in Japan

New publication, effective Aug. 2007
Specifications subject to change without notice.