

OUTDOOR UNIT

SERVICE MANUAL



No. OBH469

Wireless type
Models

MUZ-GC25VA - E1

MUZ-GC25VAH - E1

MUZ-GC35VA - E1

MUZ-GC35VAH - E1

Indoor unit service manual
MSZ-GC•VA Series (OBH468)

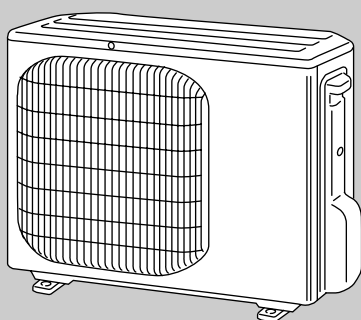

MUZ-GC25VA
MUZ-GC25VAH

CONTENTS

1. TECHNICAL CHANGES	2
2. PART NAMES AND FUNCTIONS.....	2
3. SPECIFICATION.....	3
4. NOISE CRITERIA CURVES	5
5. OUTLINES AND DIMENSIONS	6
6. WIRING DIAGRAM	7
7. REFRIGERANT SYSTEM DIAGRAM	11
8. PERFORMANCE CURVES	13
9. ACTUATOR CONTROL.....	22
10. SERVICE FUNCTIONS.....	23
11. TROUBLESHOOTING	23
12. DISASSEMBLY INSTRUCTIONS.....	42

PARTS CATALOG (OBB469)

NOTE:
RoHS compliant products have <G> mark on the spec name plate.



1

TECHNICAL CHANGES

MUZ-GA25VA -[E3] → MUZ-GC25VA -[E1]
MUZ-GA25VAH -[E3] → MUZ-GC25VAH -[E1]
MUZ-GA35VA -[E3] → MUZ-GC35VA -[E1]
MUZ-GA35VAH -[E3] → MUZ-GC35VAH -[E1]

1.Outdoor model has been changed.

2

PART NAMES AND FUNCTIONS

MUZ-GC25VA
MUZ-GC25VAH

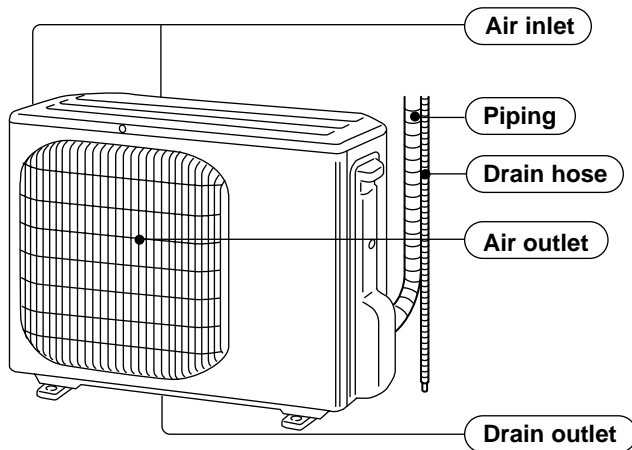

MUZ-GC35VA
MUZ-GC35VAH

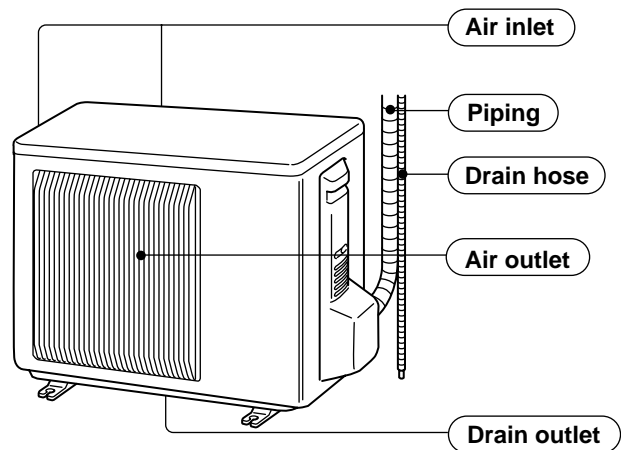

ACCESSORIES

	MUZ-GC25VA	MUZ-GC35VA
① Drain socket	1	1

3

SPECIFICATION

Outdoor model			MUZ-GC25VA MUZ-GC25VAH		MUZ-GC35VA MUZ-GC35VAH		
Function			Cooling	Heating	Cooling	Heating	
Power supply			Single phase 230V,50Hz				
Capacity	Capacity Rated frequency(Min.-Max.)	kW	2.5 (0.9-3.0)	3.2 (0.9-4.5)	3.5 (1.0-3.9)	4.0 (0.9-5.0)	
	Dehumidification	ℓ /h	1.4	—	2.0	—	
	Air flow *1	m³ /h	1,812	1,788	2,010	2,082	
Electrical data	Power outlet	A	10				
	Running current *1(Total)	A	3.6	4.2	5.0	4.9	
	Power input *1(Total)	W	665	835	1,075	1,055	
	Power factor *1(Total)	%	80	86	93	94	
	Starting current *1(Total)	A	4.2		5.0		
	Compressor motor current *1	A	3.14	3.74	4.47	4.33	
	Fan motor current *1	A	0.24		0.31	0.35	
Coefficient of performance(C.O.P) *1(Total)			3.76	3.83	3.26	3.79	
Compressor	Model		KNB065FDTH(C)		KNB073FEDH or FGDH		
	Output	W	500		550		
Fan motor Model			RA6V21-AB or BB		RC0J50-AM		
Dimensions W×H×D		mm	684×540×255		800×550×285		
Weight		kg	26		31		
Special remarks	Sound level *1	dB(A)	46	47	47	48	
	Fan speed	rpm	810	800	810/750	880/810/650	
	Fan speed regulator			1		2	3
	Refrigerant filling capacity(R410A)	kg	0.75		0.85		
	Refrigeration oil (Model)		cc	320 (NEO22)			

NOTE : Test conditions are based on ISO 5151

Cooling : Indoor Dry-bulb temperature 27°C Wet-bulb temperature 19°C

Outdoor Dry-bulb temperature 35°C

Heating : Indoor Dry-bulb temperature 20°C

Outdoor Dry-bulb temperature 7°C Wet-bulb temperature 6°C

Refrigerant piping length (one way): 5m

*1 Measured under rated operating frequency

Specifications and rating conditions of main electric parts

Item		Model	MUZ-GC25VA	MUZ-GC25VAH	MUZ-GC35VA	MUZ-GC35VAH
Current transformer	(CT)		20A			
	(CT761, CT781)		—		20A	
Smoothing capacitor	(C61,C62)		500 μ F 420V		—	
	(C63A, C63B, C63C)		—		620 μ F 420V	
Diode module	(DB61)		15A 600V		—	
	(DB65)		10A 600V		—	
	(DB61, DB65)		—		25A 600V	
Fuse	(F61)		T20AL250V			
	(F701, F801)		T3.15AL250V		—	
	(F71,F801,F901)		—		T3.15AL250V	
Defrost heater	(H)	—	230V 130W		—	230V 138W
Intelligent power module	(IPM)		10A 600V		15A 600V	
Expansion valve coil	(LEV)		CAM-MD12ME 12VDC			
Reactor	(L61)		7A 18.0mH		10A 23.0mH	
Current-detecting resistor	(R61)		45m Ω 5W			
	(R825,R831)		25m Ω 5W			
Current-limiting PTC thermistor	(PTC64)		33 Ω		—	
Current-limiting resistor	(R64A, R64B)		—		10 Ω 5W	
Terminal block	(TB1,TB2)		3P			
Relay	(X61)		2A 240V		—	
	(X63)		3A 250V			
	(X64)		20A 250V			
	(X66)		—	3A 250V	—	3A 250V
R.V. coil	(21S4)		SHF-4-10W5		STF-01AJ503	
Heater protector	(26H)		—	Open 45 $^{\circ}$ C	—	Open 45 $^{\circ}$ C
Outdoor fan motor thermal fuse			Open 152 $^{\circ}$ C (RA6V21-AB) or Open 126 $^{\circ}$ C (RA6V21-BB)		—	
IGBT	(TR821)		3A 600V			

4

NOISE CRITERIA CURVES

MUZ-GC25VA MUZ-GC25VAH

FUNCTION	SPL(dB(A))	LINE
COOLING	46	●—●
HEATING	47	○—○

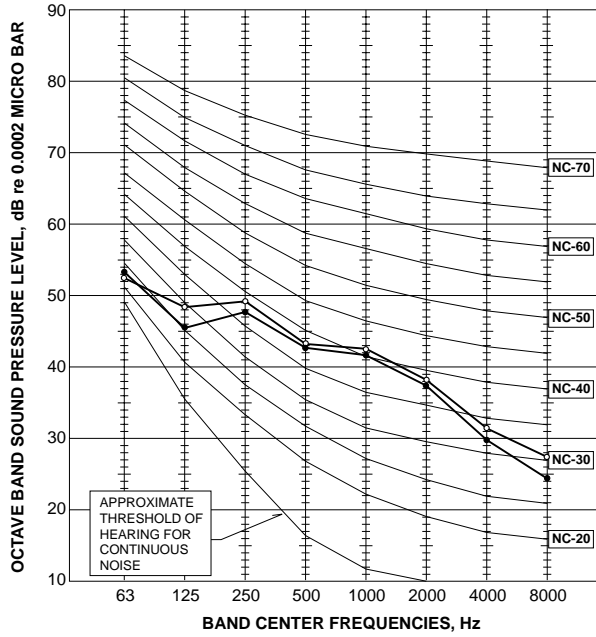

MUZ-GC35VA MUZ-GC35VAH

FUNCTION	SPL(dB(A))	LINE
COOLING	47	●—●
HEATING	48	○—○

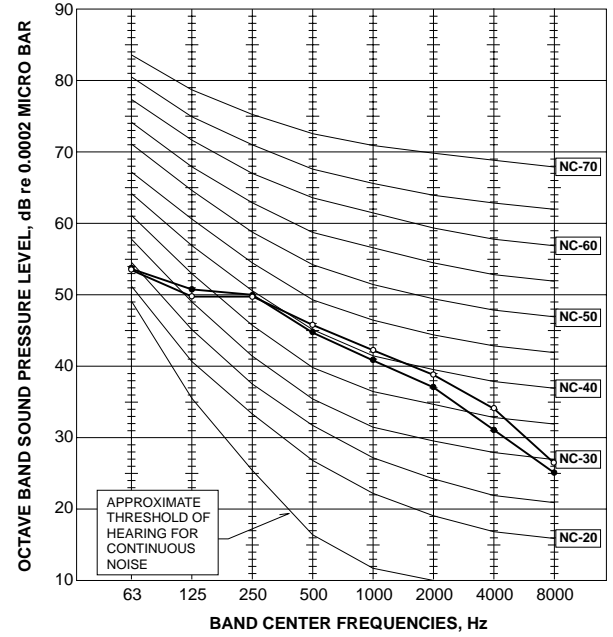

Test conditions

Cooling : Dry-bulb temperature 35°C

Heating : Dry-bulb temperature 7°C Wet-bulb temperature 6°C

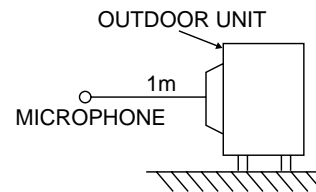

**MUZ-GC25VA
MUZ-GC25VAH**

Unit: mm

REQUIRED SPACE

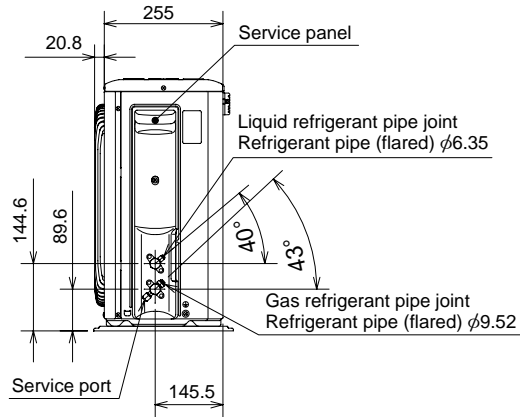
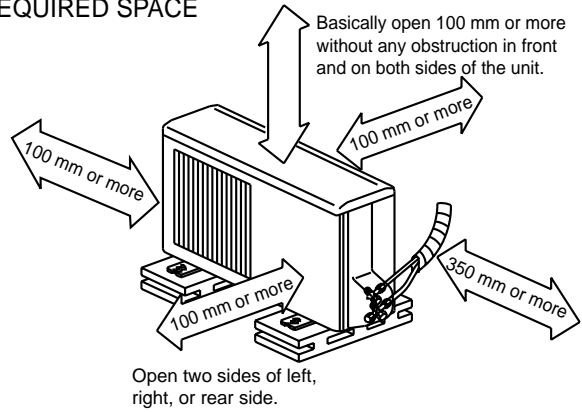
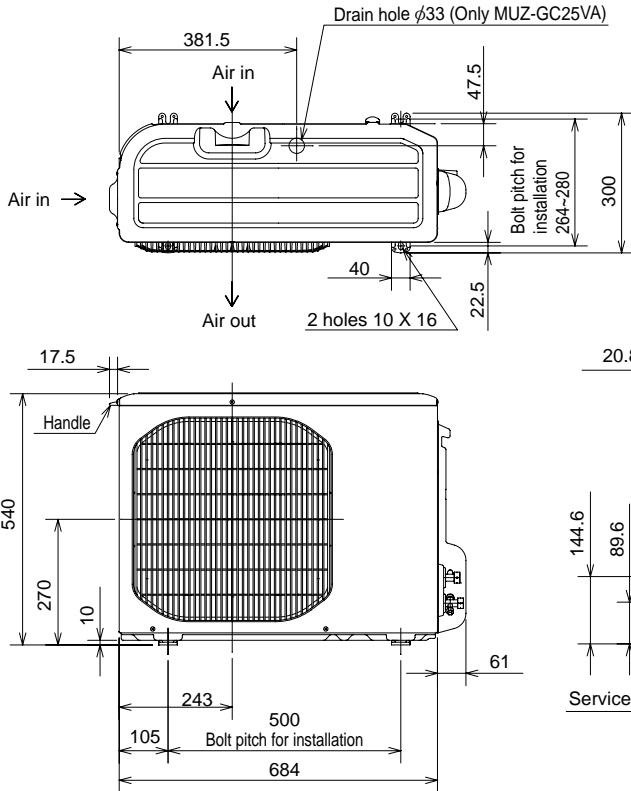

**MUZ-GC35VA
MUZ-GC35VAH**

REQUIRED SPACE

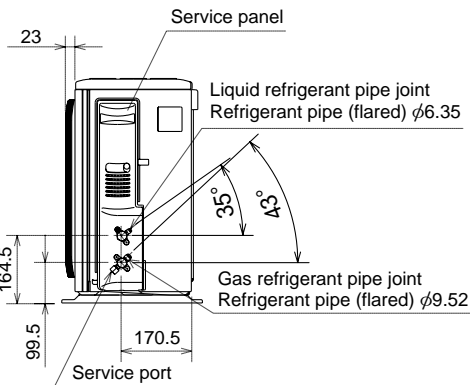
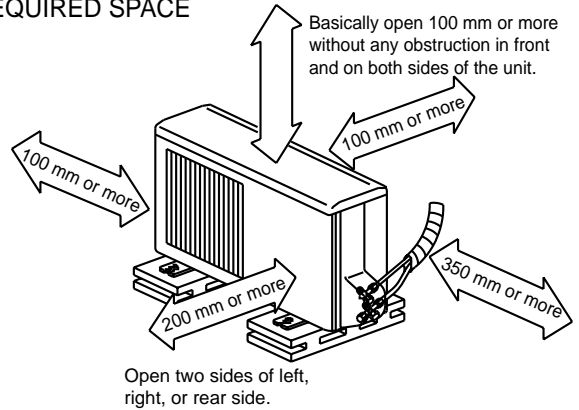
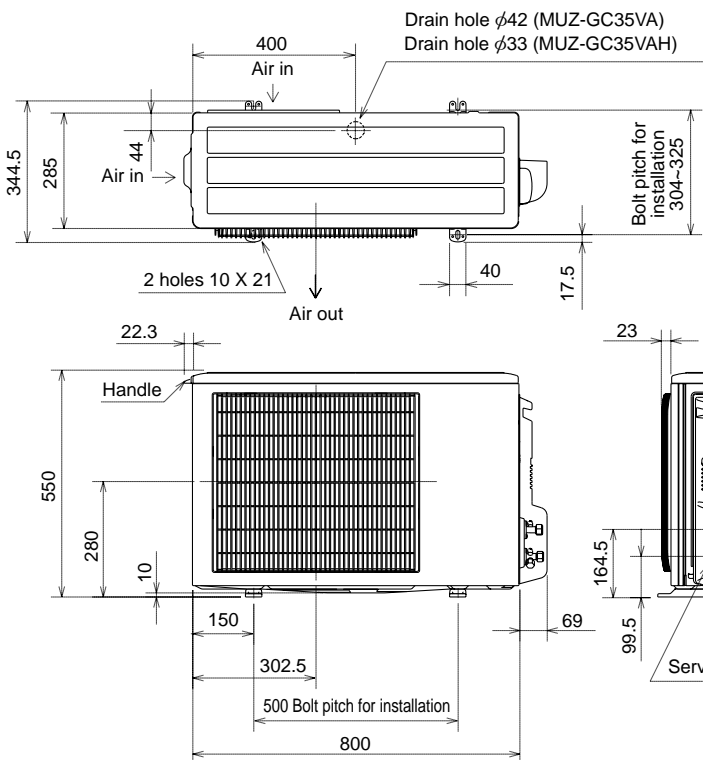

MUZ-GC25VA

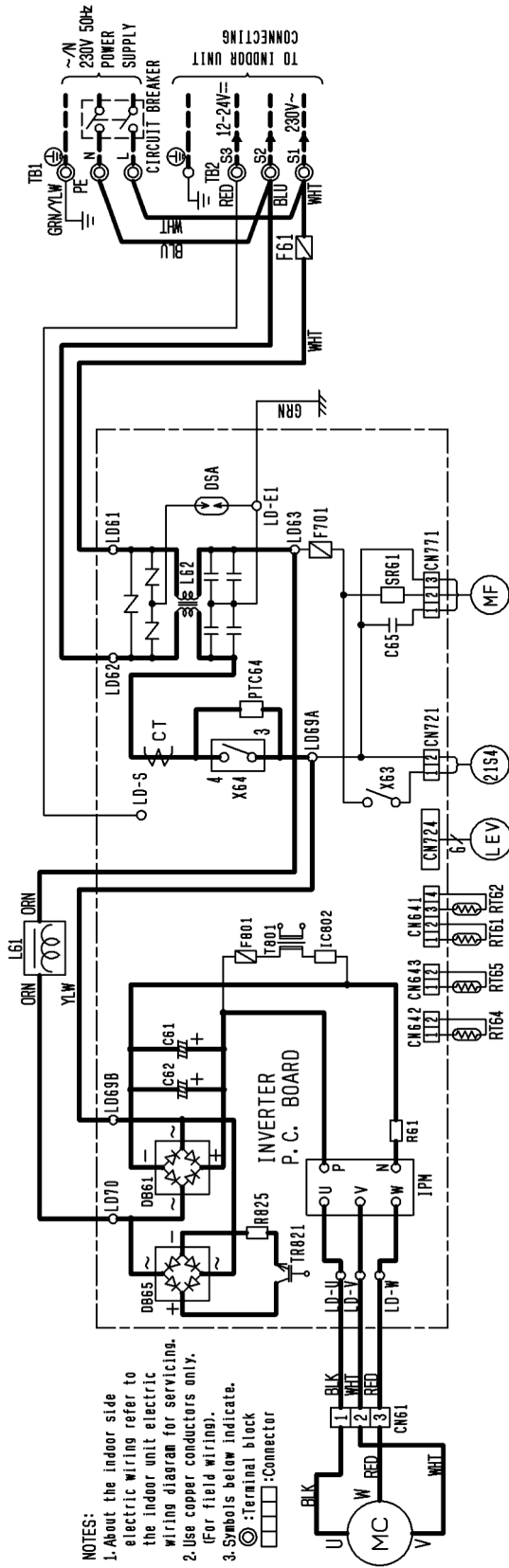

- NOTES:
1. About the indoor side electric wiring refer to the indoor unit electric wiring diagram for servicing.
 2. Use copper conductors only. (For field wiring).
 3. Symbols below indicate.
 - : Terminal block
 - : Connector

SYMBOL	NAME	SYMBOL	NAME	SYMBOL	NAME
CT	CURRENT TRANSFORMER	LEV	EXPANSION VALVE COIL	RT65	AMBIENT TEMP. THERMISTOR
C61, C62	SMOOTHING CAPACITOR	L61	REACTOR	R61, R825	CURRENT-DETECTING RESISTOR
C65	FAN MOTOR CAPACITOR	L62	CMC COIL	SR61	SOLID STATE RELAY
DB61, DB65	DIODE MODULE	MC	COMPRESSOR	TB1, TB2	TERMINAL BLOCK
DSA	SURGE ABSORBER	MF	FAN MOTOR (INNER FUSE)	TR821	SWITCHING POWER TRANSISTOR
F61	FUSE (T20AL250V)	PTC64	CIRCUIT PROTECTION	T801	TRANSFORMER
F701, F801	FUSE (T3.15AL250V)	RT61	DEFROST THERMISTOR	X63, X64	REVERSING VALVE COIL
IC802	INTELLIGENT POWER DEVICE	RT62	DISCHARGE TEMP. THERMISTOR	21S4	REVERSING VALVE COIL
IPM	INTELLIGENT POWER MODULE	RT64	FIN TEMP. THERMISTOR		

MUZ-GC25VAH

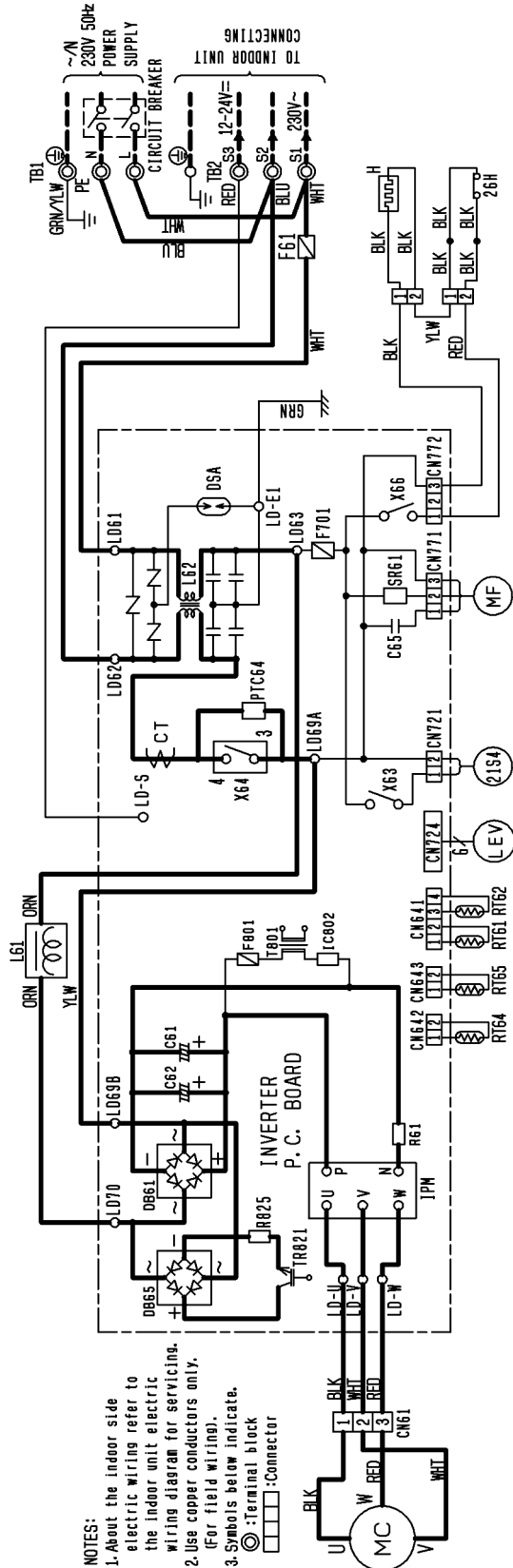

SYMBOL	NAME	SYMBOL	NAME	SYMBOL	NAME
CT	CURRENT TRANSFORMER	LEV	EXPANSION VALVE COIL	R61, R825	CURRENT-DETECTING RESISTOR
C61, C62	SMOOTHING CAPACITOR	L61	REACTOR	SR61	SOLID STATE RELAY
C65	FAN MOTOR CAPACITOR	L62	CMC COIL	TB1, TB2	TERMINAL BLOCK
DB61, DB65	DIODE MODULE	MC	COMPRESSOR	TR821	SWITCHING POWER TRANSISTOR
DSA	SURGE ABSORBER	MF	FAN MOTOR (INNER FUSE)	T801	TRANSFORMER
F61	FUSE (T20AL250V)	PTC64	CIRCUIT PROTECTION	X63, X64, X66	RELAY
F701, F801	FUSE (T3.15AL250V)	RT61	DEFROST THERMISTOR	21S4	REVERSING VALVE COIL
H	DEFROST HEATER	RT62	DISCHARGE TEMP. THERMISTOR	26H	HEATER PROTECTOR
IC802	INTELLIGENT POWER DEVICE	RT64	F-IN TEMP. THERMISTOR		
IPM	INTELLIGENT POWER MODULE	RT65	AMBIENT TEMP. THERMISTOR		

MUZ-GC35VA

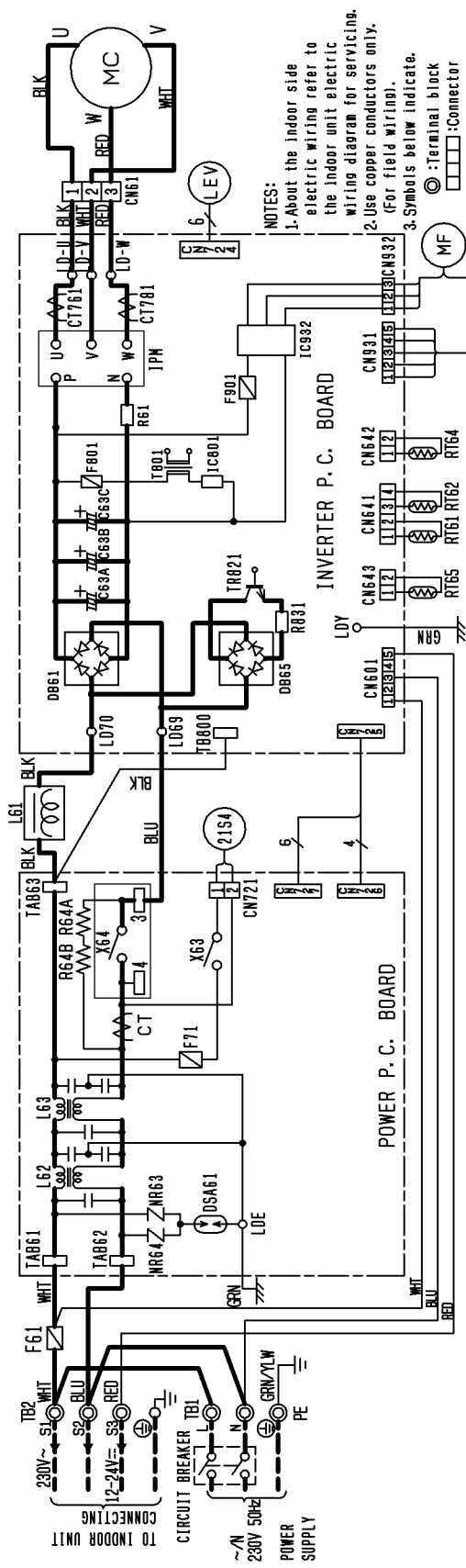

- NOTES:
1. About the indoor side electric wiring refer to the indoor unit electric wiring diagram for servicing.
 2. Use copper conductors only.
 3. Symbols below indicate.
 - ⊙: Terminal block
 - : Connector

SYMBOL	NAME	SYMBOL	NAME	SYMBOL	NAME
CT, C761, C771	CURRENT TRANSFORMER	LEV	EXPANSION VALVE COIL	RT65	AMBIENT TEMP. THERMISTOR
C63A, C63B, C63C	SMOOTHING CAPACITOR	L61	REACTOR	R61, R831	CURRENT-DETECTING RESISTOR
DB61, DB65	DIODE MODULE	L62, L63	CNC COIL	R64A, R64B	CURRENT-LIMITING RESISTOR
DS461	SURGE ABSORBER	MC	COMPRESSOR	TB1, TB2	TERMINAL BLOCK
F61	FUSE (T20A/250V)	MF	FAN MOTOR	TR821	SWITCHING POWER TRANSISTOR
F71	FUSE (T3.15A/250V)	NR63, NR64	VARISTOR	T801	TRANSFORMER
F801, F901	FUSE (T3.15A/250V)	RT61	DEFROST THERMISTOR	X63, X64	RELAY
IC801	INTELLIGENT POWER DEVICE	RT62	DISCHARGE TEMP. THERMISTOR	21S4	REVERSING VALVE COIL
IPM, IC932	INTELLIGENT POWER MODULE	RT64	FIN TEMP. THERMISTOR		

MUZ-GC25VA
MUZ-GC25VAH

Unit:mm

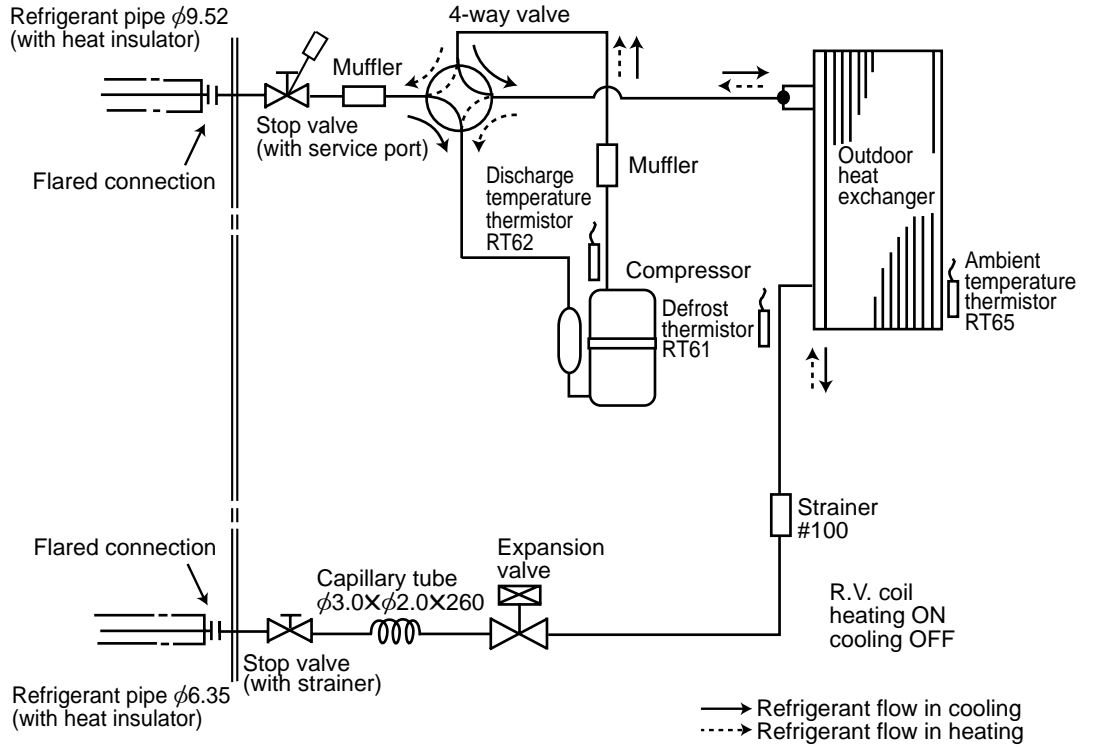

MUZ-GC35VA
MUZ-GC35VAH

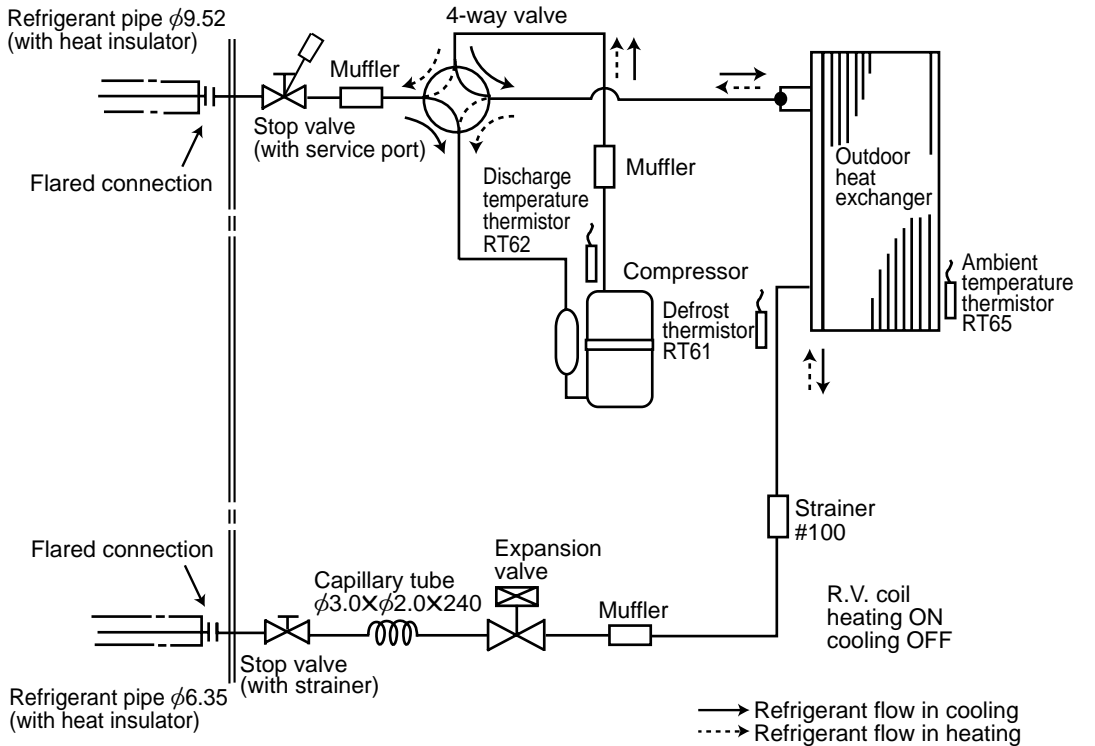

MAX. REFRIGERANT PIPING LENGTH and MAX. HEIGHT DIFFERENCE

Model	Refrigerant piping : m		Piping size O.D : mm	
	Max. length	Max. Height difference	Gas	Liquid
	A	B		
MUZ-GC25VA MUZ-GC25VAH	20	12	9.52	6.35
MUZ-GC35VA MUZ-GC35VAH				

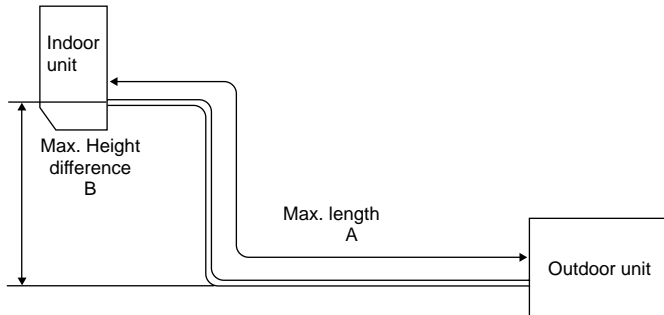

ADDITIONAL REFRIGERANT CHARGE (R410A:g)

Model	Outdoor unit precharged	Refrigerant piping length (one way)											
		5m	6m	7m	8m	9m	10m	11m	12m	13m	14m	15m	20m
MUZ-GC25VA	750	0	0	0	90	120	150	180	210	240	270	300	450
MUZ-GC25VAH													
MUZ-GC35VA	850	0	0	0	90	120	150	180	210	240	270	300	450
MUZ-GC35VAH													

Calculation : $Xg=30 \text{ g/m} \times (\text{Refrigerant piping length (m)}-5)$

NOTE: Refrigerant piping exceeding 7 m requires additional refrigerant charge according to the calculation.

MUZ-GC25VA MUZ-GC35VA
MUZ-GC25VAH MUZ-GC35VAH

The standard data contained in these specifications apply only to the operation of the air conditioner under normal conditions. Since operating conditions vary according to the areas where these units are installed, the following information has been provided to clarify the operating characteristics of the air conditioner under the conditions indicated by the performance curve.

(1) GUARANTEED VOLTAGE

198 ~ 264V, 50Hz

(2) AIR FLOW

Air flow should be set at MAX.

(3) MAIN READINGS

- | | | |
|---|-------|-----------|
| (1) Indoor intake air wet-bulb temperature : | °C WB | } Cooling |
| (2) Indoor outlet air wet-bulb temperature : | °C WB | |
| (3) Outdoor intake air dry-bulb temperature : | °C DB | |
| (4) Total input: | W | } Heating |
| (5) Indoor intake air dry-bulb temperature : | °C DB | |
| (6) Outdoor intake air wet-bulb temperature : | °C WB | |
| (7) Total input : | W | |

Indoor air wet/dry-bulb temperature difference on the left side of the following chart shows the difference between the indoor intake air wet/dry-bulb temperature and the indoor outlet air wet/dry-bulb temperature for your reference at service.

How to measure the indoor air wet-bulb / dry-bulb temperature difference

1. Attach at least 2 sets of wet and dry-bulb thermometers to the indoor air intake as shown in the figure, and at least 2 sets of wet and dry-bulb thermometers to the indoor air outlet. The thermometers must be attached to the position where air speed is high.
2. Attach at least 2 sets of wet and dry-bulb thermometers to the outdoor air intake. Cover the thermometers to prevent direct rays of the sun.
3. Check that the air filter is cleaned.
4. Open windows and doors of room.
5. Press the EMERGENCY OPERATION switch once (twice) to start the EMERGENCY COOL (HEAT) MODE.
6. When system stabilizes after more than 15 minutes, measure temperature and take an average temperature.
7. 10 minutes later, measure temperature again and check that the temperature does not change.

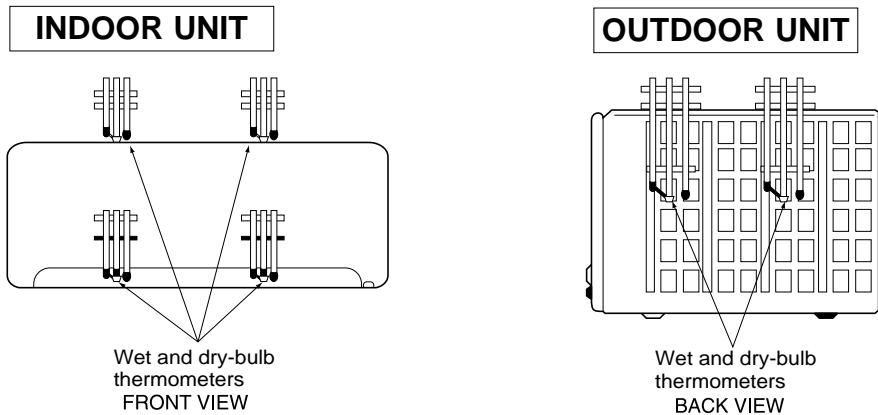

8-1. Capacity and input curves

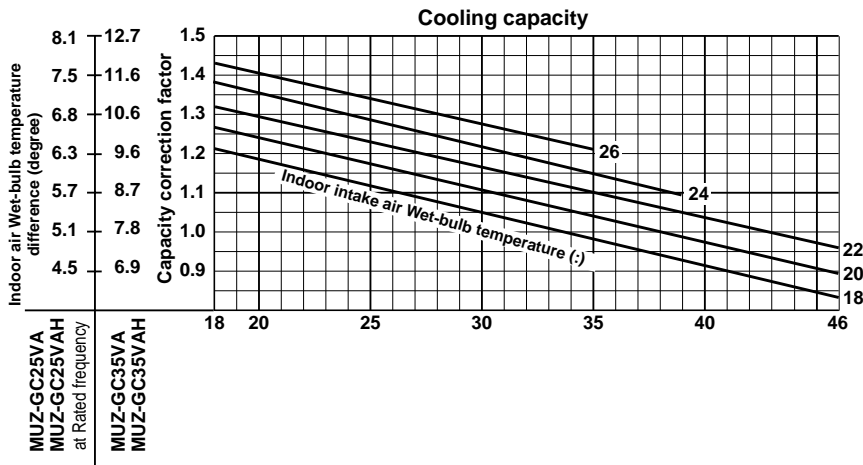

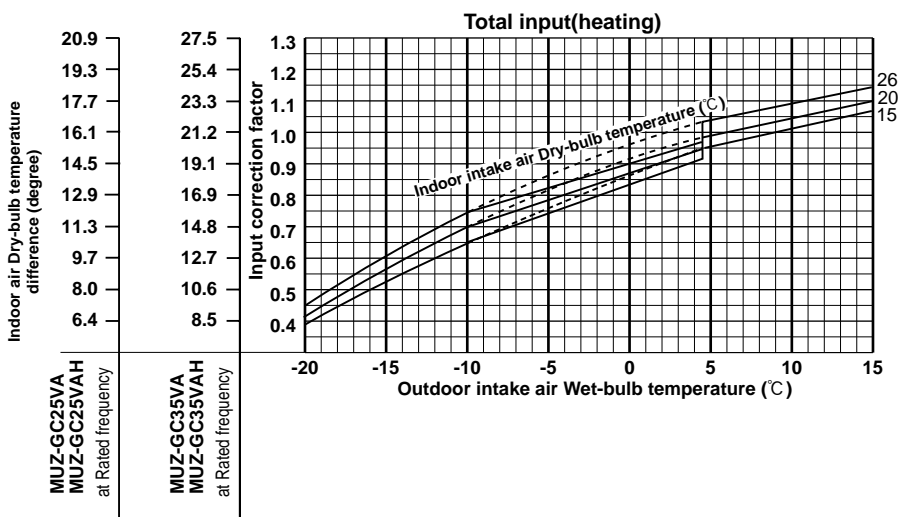
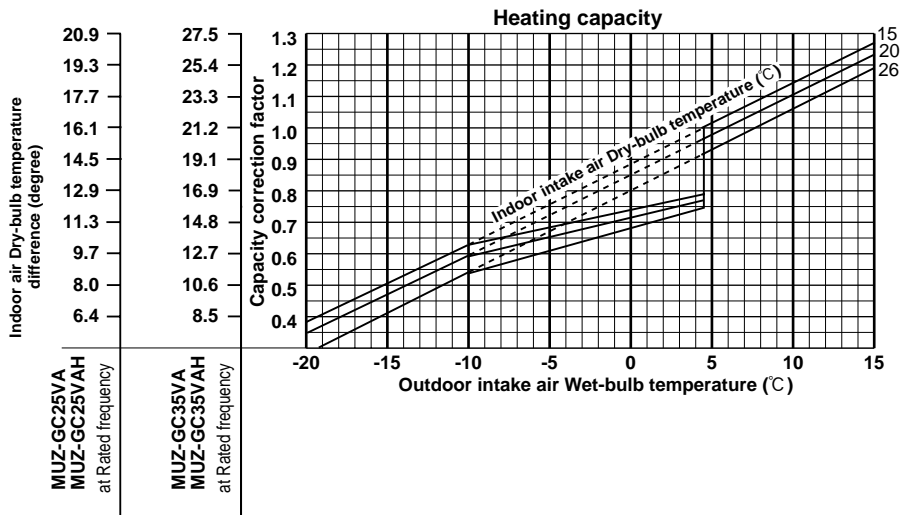
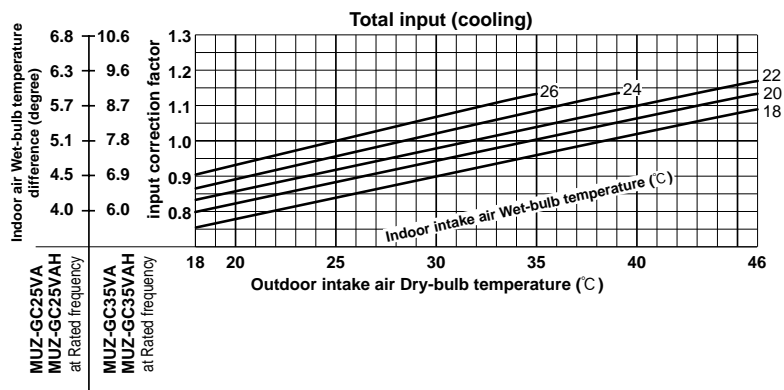

NOTE: The above broken lines are for the heating operation without any frost and defrost operation.

8-2. Capacity and input correction by operational frequency of compressor

MUZ-GC25VA MUZ-GC25VAH

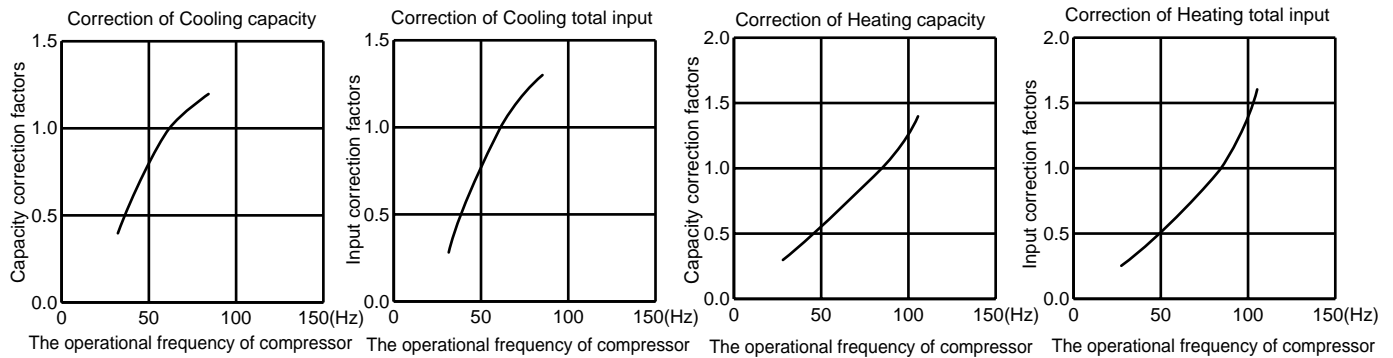

MUZ-GC35VA MUZ-GC35VAH

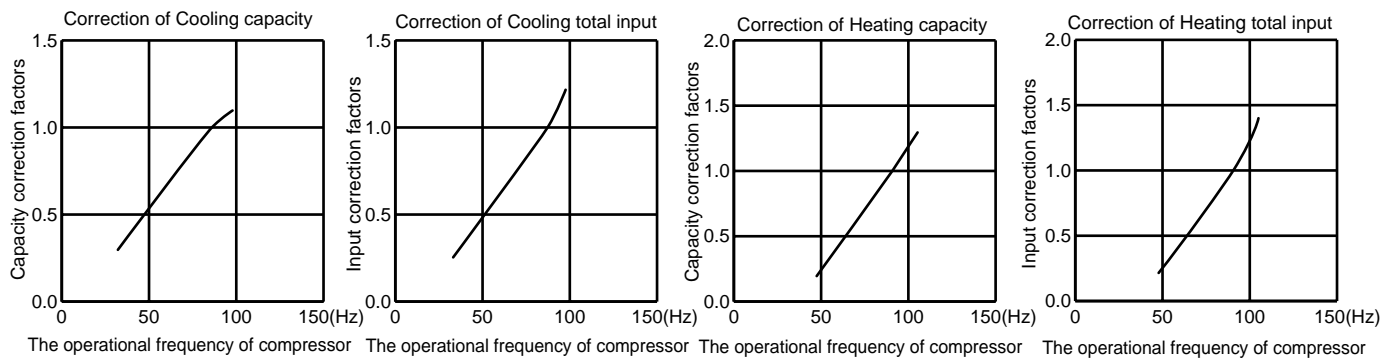

8-3. Test run operation (How to operate fixed-frequency operation)

1. Press EMERGENCY OPERATION switch to COOL or HEAT mode (COOL : Press once, HEAT : Press twice).
2. Test run operation starts and continues to operate for 30 minutes.
3. Compressor operates at rated frequency in COOL mode or 58Hz in HEAT mode.
4. Indoor fan operates at High speed.
5. After 30 minutes, test run operation finishes and EMERGENCY OPERATION starts (Operation frequency of compressor varies).
6. To cancel test run operation (EMERGENCY OPERATION), press EMERGENCY OPERATION switch or any button on remote controller.

8-4. Outdoor low pressure and outdoor unit current

COOL operation

- ① Both indoor and outdoor unit are under the same temperature/humidity condition.
- ② Operation : TEST RUN OPERATION (refer to 8-3.)

Dry-bulb temperature(°C)	Relative humidity(%)
20	50
25	60
30	70

Outdoor low pressure

MUZ-GC25VA MUZ-GC25VAH

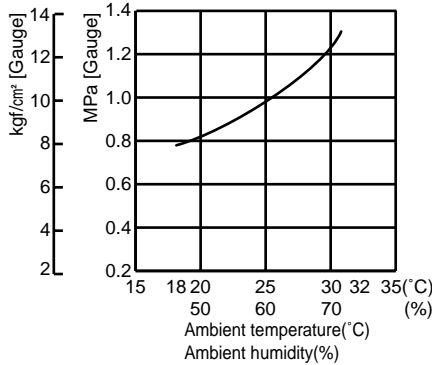

MUZ-GC35VA MUZ-GC35VAH

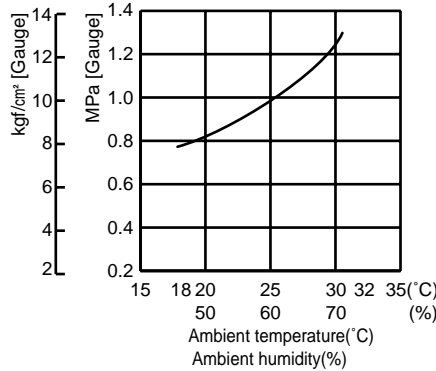

NOTE :

The unit of pressure has been changed to MPa on the international system of units (SI unit system).

The conversion factor is:

$$1(\text{MPa [Gauge]}) = 10.2(\text{kgf/cm}^2 \text{ [Gauge]})$$

Outdoor unit current

MUZ-GC25VA MUZ-GC25VAH

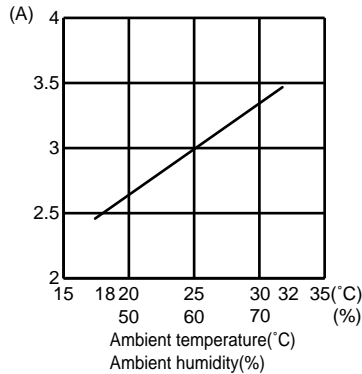

MUZ-GC35VA MUZ-GC35VAH

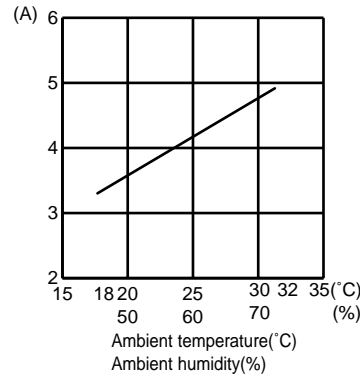

HEAT operation

① Condition :	Indoor	Outdoor			
		2	7	15	20.0
Dry bulb temperature (°C)	20.0	2	7	15	20.0
Wet bulb temperature (°C)	14.5	1	6	12	14.5

- ② Operation : Test run operation (refer to 8-3.)

Outdoor unit current

MUZ-GC25VA MUZ-GC25VAH

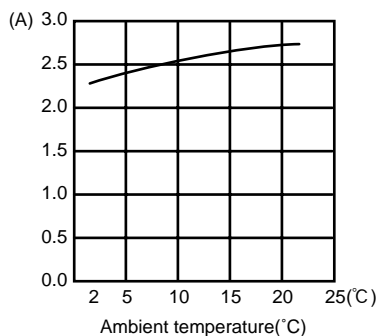

MUZ-GC35VA MUZ-GC35VAH

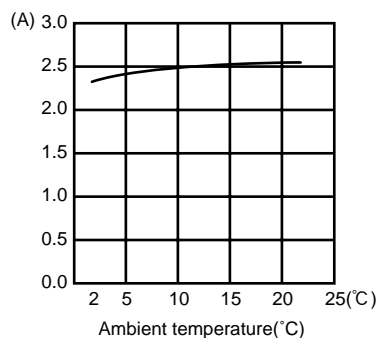

PERFORMANCE DATA COOL operation at Rated frequency

MUZ-GC25VA MUZ-GC25VAH

CAPACITY:2.5(kW) SHF:0.79 INPUT:665(W)

		OUTDOOR DB(°C)															
INDOOR DB(°C)	INDOOR WB(°C)	21				25				27				30			
		Q	SHC	SHF	INPUT	Q	SHC	SHF	INPUT	Q	SHC	SHF	INPUT	Q	SHC	SHF	INPUT
21	18	2.94	1.79	0.61	532	2.81	1.72	0.61	559	2.70	1.65	0.61	585	2.60	1.59	0.61	612
21	20	3.06	1.50	0.49	559	2.94	1.44	0.49	592	2.85	1.40	0.49	605	2.75	1.35	0.49	632
22	18	2.94	1.91	0.65	532	2.81	1.83	0.65	559	2.70	1.76	0.65	585	2.60	1.69	0.65	612
22	20	3.06	1.62	0.53	559	2.94	1.56	0.53	592	2.85	1.51	0.53	605	2.75	1.46	0.53	632
22	22	3.19	1.31	0.41	579	3.08	1.26	0.41	615	3.00	1.23	0.41	632	2.88	1.18	0.41	658
23	18	2.94	2.03	0.69	532	2.81	1.94	0.69	559	2.70	1.86	0.69	585	2.60	1.79	0.69	612
23	20	3.06	1.75	0.57	559	2.94	1.67	0.57	592	2.85	1.62	0.57	605	2.75	1.57	0.57	632
23	22	3.19	1.43	0.45	579	3.08	1.38	0.45	615	3.00	1.35	0.45	632	2.88	1.29	0.45	658
24	18	2.94	2.14	0.73	532	2.81	2.05	0.73	559	2.70	1.97	0.73	585	2.60	1.90	0.73	612
24	20	3.06	1.87	0.61	559	2.94	1.79	0.61	592	2.85	1.74	0.61	605	2.75	1.68	0.61	632
24	22	3.19	1.56	0.49	579	3.08	1.51	0.49	615	3.00	1.47	0.49	632	2.88	1.41	0.49	658
24	24	3.35	1.24	0.37	605	3.23	1.19	0.37	638	3.15	1.17	0.37	658	3.05	1.13	0.37	692
25	18	2.94	2.26	0.77	532	2.81	2.17	0.77	559	2.70	2.08	0.77	585	2.60	2.00	0.77	612
25	20	3.06	1.99	0.65	559	2.94	1.91	0.65	592	2.85	1.85	0.65	605	2.75	1.79	0.65	632
25	22	3.19	1.69	0.53	579	3.08	1.63	0.53	615	3.00	1.59	0.53	632	2.88	1.52	0.53	658
25	24	3.35	1.37	0.41	605	3.23	1.32	0.41	638	3.15	1.29	0.41	658	3.05	1.25	0.41	692
26	18	2.94	2.38	0.81	532	2.81	2.28	0.81	559	2.70	2.19	0.81	585	2.60	2.11	0.81	612
26	20	3.06	2.11	0.69	559	2.94	2.03	0.69	592	2.85	1.97	0.69	605	2.75	1.90	0.69	632
26	22	3.19	1.82	0.57	579	3.08	1.75	0.57	615	3.00	1.71	0.57	632	2.88	1.64	0.57	658
26	24	3.35	1.51	0.45	605	3.23	1.45	0.45	638	3.15	1.42	0.45	658	3.05	1.37	0.45	692
26	26	3.45	1.14	0.33	638	3.35	1.11	0.33	672	3.30	1.09	0.33	692	3.20	1.06	0.33	712
27	18	2.94	2.50	0.85	532	2.81	2.39	0.85	559	2.70	2.30	0.85	585	2.60	2.21	0.85	612
27	20	3.06	2.24	0.73	559	2.94	2.14	0.73	592	2.85	2.08	0.73	605	2.75	2.01	0.73	632
27	22	3.19	1.94	0.61	579	3.08	1.88	0.61	615	3.00	1.83	0.61	632	2.88	1.75	0.61	658
27	24	3.35	1.64	0.49	605	3.23	1.58	0.49	638	3.15	1.54	0.49	658	3.05	1.49	0.49	692
27	26	3.45	1.28	0.37	638	3.35	1.24	0.37	672	3.30	1.22	0.37	692	3.20	1.18	0.37	712
28	18	2.94	2.61	0.89	532	2.81	2.50	0.89	559	2.70	2.40	0.89	585	2.60	2.31	0.89	612
28	20	3.06	2.36	0.77	559	2.94	2.26	0.77	592	2.85	2.19	0.77	605	2.75	2.12	0.77	632
28	22	3.19	2.07	0.65	579	3.08	2.00	0.65	615	3.00	1.95	0.65	632	2.88	1.87	0.65	658
28	24	3.35	1.78	0.53	605	3.23	1.71	0.53	638	3.15	1.67	0.53	658	3.05	1.62	0.53	692
28	26	3.45	1.41	0.41	638	3.35	1.37	0.41	672	3.30	1.35	0.41	692	3.20	1.31	0.41	712
29	18	2.94	2.73	0.93	532	2.81	2.62	0.93	559	2.70	2.51	0.93	585	2.60	2.42	0.93	612
29	20	3.06	2.48	0.81	559	2.94	2.38	0.81	592	2.85	2.31	0.81	605	2.75	2.23	0.81	632
29	22	3.19	2.20	0.69	579	3.08	2.12	0.69	615	3.00	2.07	0.69	632	2.88	1.98	0.69	658
29	24	3.35	1.91	0.57	605	3.23	1.84	0.57	638	3.15	1.80	0.57	658	3.05	1.74	0.57	692
29	26	3.45	1.55	0.45	638	3.35	1.51	0.45	672	3.30	1.49	0.45	692	3.20	1.44	0.45	712
30	18	2.94	2.85	0.97	532	2.81	2.73	0.97	559	2.70	2.62	0.97	585	2.60	2.52	0.97	612
30	20	3.06	2.60	0.85	559	2.94	2.50	0.85	592	2.85	2.42	0.85	605	2.75	2.34	0.85	632
30	22	3.19	2.33	0.73	579	3.08	2.24	0.73	615	3.00	2.19	0.73	632	2.88	2.10	0.73	658
30	24	3.35	2.04	0.61	605	3.23	1.97	0.61	638	3.15	1.92	0.61	658	3.05	1.86	0.61	692
30	26	3.45	1.69	0.49	638	3.35	1.64	0.49	672	3.30	1.62	0.49	692	3.20	1.57	0.49	712
31	18	2.94	2.97	1.01	532	2.81	2.84	1.01	559	2.70	2.73	1.01	585	2.60	2.63	1.01	612
31	20	3.06	2.73	0.89	559	2.94	2.61	0.89	592	2.85	2.54	0.89	605	2.75	2.45	0.89	632
31	22	3.19	2.45	0.77	579	3.08	2.37	0.77	615	3.00	2.31	0.77	632	2.88	2.21	0.77	658
31	24	3.35	2.18	0.65	605	3.23	2.10	0.65	638	3.15	2.05	0.65	658	3.05	1.98	0.65	692
31	26	3.45	1.83	0.53	638	3.35	1.78	0.53	672	3.30	1.75	0.53	692	3.20	1.70	0.53	712
32	18	2.94	3.08	1.05	532	2.81	2.95	1.05	559	2.70	2.84	1.05	585	2.60	2.73	1.05	612
32	20	3.06	2.85	0.93	559	2.94	2.73	0.93	592	2.85	2.65	0.93	605	2.75	2.56	0.93	632
32	22	3.19	2.58	0.81	579	3.08	2.49	0.81	615	3.00	2.43	0.81	632	2.88	2.33	0.81	658
32	24	3.35	2.31	0.69	605	3.23	2.23	0.69	638	3.15	2.17	0.69	658	3.05	2.10	0.69	692
32	26	3.45	1.97	0.57	638	3.35	1.91	0.57	672	3.30	1.88	0.57	692	3.20	1.82	0.57	712

NOTE: Q : Total capacity (kW) SHF : Sensible heat factor DB : Dry-bulb temperature
 SHC : Sensible heat capacity (kW) INPUT : Total power input (W) WB : Wet-bulb temperature

PERFORMANCE DATA COOL operation at Rated frequency

MUZ-GC25VA MUZ-GC25VAH

CAPACITY:2.5(kW) SHF:0.79 INPUT:665(W)

		OUTDOOR DB(°C)											
INDOOR DB (°C)	INDOOR WB (°C)	35				40				46			
		Q	SHC	SHF	INPUT	Q	SHC	SHF	INPUT	Q	SHC	SHF	INPUT
21	18	2.45	1.49	0.61	652	2.25	1.37	0.61	692	2.08	1.27	0.61	718
21	20	2.58	1.26	0.49	678	2.40	1.18	0.49	712	2.23	1.09	0.49	751
22	18	2.45	1.59	0.65	652	2.25	1.46	0.65	692	2.08	1.35	0.65	718
22	20	2.58	1.36	0.53	678	2.40	1.27	0.53	712	2.23	1.18	0.53	751
22	22	2.73	1.12	0.41	705	2.55	1.05	0.41	745	2.38	0.97	0.41	771
23	18	2.45	1.69	0.69	652	2.25	1.55	0.69	692	2.08	1.43	0.69	718
23	20	2.58	1.47	0.57	678	2.40	1.37	0.57	712	2.23	1.27	0.57	751
23	22	2.73	1.23	0.45	705	2.55	1.15	0.45	745	2.38	1.07	0.45	771
24	18	2.45	1.79	0.73	652	2.25	1.64	0.73	692	2.08	1.51	0.73	718
24	20	2.58	1.57	0.61	678	2.40	1.46	0.61	712	2.23	1.36	0.61	751
24	22	2.73	1.34	0.49	705	2.55	1.25	0.49	745	2.38	1.16	0.49	771
24	24	2.88	1.06	0.37	732	2.70	1.00	0.37	765	2.55	0.94	0.37	798
25	18	2.45	1.89	0.77	652	2.25	1.73	0.77	692	2.08	1.60	0.77	718
25	20	2.58	1.67	0.65	678	2.40	1.56	0.65	712	2.23	1.45	0.65	751
25	22	2.73	1.44	0.53	705	2.55	1.35	0.53	745	2.38	1.26	0.53	771
25	24	2.88	1.18	0.41	732	2.70	1.11	0.41	765	2.55	1.05	0.41	798
26	18	2.45	1.98	0.81	652	2.25	1.82	0.81	692	2.08	1.68	0.81	718
26	20	2.58	1.78	0.69	678	2.40	1.66	0.69	712	2.23	1.54	0.69	751
26	22	2.73	1.55	0.57	705	2.55	1.45	0.57	745	2.38	1.35	0.57	771
26	24	2.88	1.29	0.45	732	2.70	1.22	0.45	765	2.55	1.15	0.45	798
26	26	3.03	1.00	0.33	758	2.85	0.94	0.33	791	2.68	0.88	0.33	825
27	18	2.45	2.08	0.85	652	2.25	1.91	0.85	692	2.08	1.76	0.85	718
27	20	2.58	1.88	0.73	678	2.40	1.75	0.73	712	2.23	1.62	0.73	751
27	22	2.73	1.66	0.61	705	2.55	1.56	0.61	745	2.38	1.45	0.61	771
27	24	2.88	1.41	0.49	732	2.70	1.32	0.49	765	2.55	1.25	0.49	798
27	26	3.03	1.12	0.37	758	2.85	1.05	0.37	791	2.68	0.99	0.37	825
28	18	2.45	2.18	0.89	652	2.25	2.00	0.89	692	2.08	1.85	0.89	718
28	20	2.58	1.98	0.77	678	2.40	1.85	0.77	712	2.23	1.71	0.77	751
28	22	2.73	1.77	0.65	705	2.55	1.66	0.65	745	2.38	1.54	0.65	771
28	24	2.88	1.52	0.53	732	2.70	1.43	0.53	765	2.55	1.35	0.53	798
28	26	3.03	1.24	0.41	758	2.85	1.17	0.41	791	2.68	1.10	0.41	825
29	18	2.45	2.28	0.93	652	2.25	2.09	0.93	692	2.08	1.93	0.93	718
29	20	2.58	2.09	0.81	678	2.40	1.94	0.81	712	2.23	1.80	0.81	751
29	22	2.73	1.88	0.69	705	2.55	1.76	0.69	745	2.38	1.64	0.69	771
29	24	2.88	1.64	0.57	732	2.70	1.54	0.57	765	2.55	1.45	0.57	798
29	26	3.03	1.36	0.45	758	2.85	1.28	0.45	791	2.68	1.20	0.45	825
30	18	2.45	2.38	0.97	652	2.25	2.18	0.97	692	2.08	2.01	0.97	718
30	20	2.58	2.19	0.85	678	2.40	2.04	0.85	712	2.23	1.89	0.85	751
30	22	2.73	1.99	0.73	705	2.55	1.86	0.73	745	2.38	1.73	0.73	771
30	24	2.88	1.75	0.61	732	2.70	1.65	0.61	765	2.55	1.56	0.61	798
30	26	3.03	1.48	0.49	758	2.85	1.40	0.49	791	2.68	1.31	0.49	825
31	18	2.45	2.47	1.01	652	2.25	2.27	1.01	692	2.08	2.10	1.01	718
31	20	2.58	2.29	0.89	678	2.40	2.14	0.89	712	2.23	1.98	0.89	751
31	22	2.73	2.10	0.77	705	2.55	1.96	0.77	745	2.38	1.83	0.77	771
31	24	2.88	1.87	0.65	732	2.70	1.76	0.65	765	2.55	1.66	0.65	798
31	26	3.03	1.60	0.53	758	2.85	1.51	0.53	791	2.68	1.42	0.53	825
32	18	2.45	2.57	1.05	652	2.25	2.36	1.05	692	2.08	2.18	1.05	718
32	20	2.58	2.39	0.93	678	2.40	2.23	0.93	712	2.23	2.07	0.93	751
32	22	2.73	2.21	0.81	705	2.55	2.07	0.81	745	2.38	1.92	0.81	771
32	24	2.88	1.98	0.69	732	2.70	1.86	0.69	765	2.55	1.76	0.69	798
32	26	3.03	1.72	0.57	758	2.85	1.62	0.57	791	2.68	1.52	0.57	825

NOTE: Q : Total capacity (kW) SHF : Sensible heat factor DB : Dry-bulb temperature
 SHC : Sensible heat capacity (kW) INPUT : Total power input (W) WB : Wet-bulb temperature

PERFORMANCE DATA COOL operation at Rated frequency

MUZ-GC35VA MUZ-GC35VAH

CAPACITY:3.5(kW) SHF:0.76 INPUT:1075(W)

		OUTDOOR DB(°C)															
INDOOR DB(°C)	INDOOR WB(°C)	21				25				27				30			
		Q	SHC	SHF	INPUT	Q	SHC	SHF	INPUT	Q	SHC	SHF	INPUT	Q	SHC	SHF	INPUT
21	18	4.11	2.39	0.58	860	3.94	2.28	0.58	903	3.78	2.19	0.58	946	3.64	2.11	0.58	989
21	20	4.29	1.97	0.46	903	4.11	1.89	0.46	957	3.99	1.84	0.46	978	3.85	1.77	0.46	1021
22	18	4.11	2.55	0.62	860	3.94	2.44	0.62	903	3.78	2.34	0.62	946	3.64	2.26	0.62	989
22	20	4.29	2.14	0.50	903	4.11	2.06	0.50	957	3.99	2.00	0.50	978	3.85	1.93	0.50	1021
22	22	4.46	1.70	0.38	935	4.31	1.64	0.38	994	4.20	1.60	0.38	1021	4.03	1.53	0.38	1064
23	18	4.11	2.71	0.66	860	3.94	2.60	0.66	903	3.78	2.49	0.66	946	3.64	2.40	0.66	989
23	20	4.29	2.32	0.54	903	4.11	2.22	0.54	957	3.99	2.15	0.54	978	3.85	2.08	0.54	1021
23	22	4.46	1.87	0.42	935	4.31	1.81	0.42	994	4.20	1.76	0.42	1021	4.03	1.69	0.42	1064
24	18	4.11	2.88	0.70	860	3.94	2.76	0.70	903	3.78	2.65	0.70	946	3.64	2.55	0.70	989
24	20	4.29	2.49	0.58	903	4.11	2.39	0.58	957	3.99	2.31	0.58	978	3.85	2.23	0.58	1021
24	22	4.46	2.05	0.46	935	4.31	1.98	0.46	994	4.20	1.93	0.46	1021	4.03	1.85	0.46	1064
24	24	4.69	1.59	0.34	978	4.52	1.54	0.34	1032	4.41	1.50	0.34	1064	4.27	1.45	0.34	1118
25	18	4.11	3.04	0.74	860	3.94	2.91	0.74	903	3.78	2.80	0.74	946	3.64	2.69	0.74	989
25	20	4.29	2.66	0.62	903	4.11	2.55	0.62	957	3.99	2.47	0.62	978	3.85	2.39	0.62	1021
25	22	4.46	2.23	0.50	935	4.31	2.15	0.50	994	4.20	2.10	0.50	1021	4.03	2.01	0.50	1064
25	24	4.69	1.78	0.38	978	4.52	1.72	0.38	1032	4.41	1.68	0.38	1064	4.27	1.62	0.38	1118
26	18	4.11	3.21	0.78	860	3.94	3.07	0.78	903	3.78	2.95	0.78	946	3.64	2.84	0.78	989
26	20	4.29	2.83	0.66	903	4.11	2.71	0.66	957	3.99	2.63	0.66	978	3.85	2.54	0.66	1021
26	22	4.46	2.41	0.54	935	4.31	2.32	0.54	994	4.20	2.27	0.54	1021	4.03	2.17	0.54	1064
26	24	4.69	1.97	0.42	978	4.52	1.90	0.42	1032	4.41	1.85	0.42	1064	4.27	1.79	0.42	1118
26	26	4.83	1.45	0.30	1032	4.69	1.41	0.30	1086	4.62	1.39	0.30	1118	4.48	1.34	0.30	1150
27	18	4.11	3.37	0.82	860	3.94	3.23	0.82	903	3.78	3.10	0.82	946	3.64	2.98	0.82	989
27	20	4.29	3.00	0.70	903	4.11	2.88	0.70	957	3.99	2.79	0.70	978	3.85	2.70	0.70	1021
27	22	4.46	2.59	0.58	935	4.31	2.50	0.58	994	4.20	2.44	0.58	1021	4.03	2.33	0.58	1064
27	24	4.69	2.16	0.46	978	4.52	2.08	0.46	1032	4.41	2.03	0.46	1064	4.27	1.96	0.46	1118
27	26	4.83	1.64	0.34	1032	4.69	1.59	0.34	1086	4.62	1.57	0.34	1118	4.48	1.52	0.34	1150
28	18	4.11	3.54	0.86	860	3.94	3.39	0.86	903	3.78	3.25	0.86	946	3.64	3.13	0.86	989
28	20	4.29	3.17	0.74	903	4.11	3.04	0.74	957	3.99	2.95	0.74	978	3.85	2.85	0.74	1021
28	22	4.46	2.77	0.62	935	4.31	2.67	0.62	994	4.20	2.60	0.62	1021	4.03	2.50	0.62	1064
28	24	4.69	2.35	0.50	978	4.52	2.26	0.50	1032	4.41	2.21	0.50	1064	4.27	2.14	0.50	1118
28	26	4.83	1.84	0.38	1032	4.69	1.78	0.38	1086	4.62	1.76	0.38	1118	4.48	1.70	0.38	1150
29	18	4.11	3.70	0.90	860	3.94	3.54	0.90	903	3.78	3.40	0.90	946	3.64	3.28	0.90	989
29	20	4.29	3.34	0.78	903	4.11	3.21	0.78	957	3.99	3.11	0.78	978	3.85	3.00	0.78	1021
29	22	4.46	2.95	0.66	935	4.31	2.84	0.66	994	4.20	2.77	0.66	1021	4.03	2.66	0.66	1064
29	24	4.69	2.53	0.54	978	4.52	2.44	0.54	1032	4.41	2.38	0.54	1064	4.27	2.31	0.54	1118
29	26	4.83	2.03	0.42	1032	4.69	1.97	0.42	1086	4.62	1.94	0.42	1118	4.48	1.88	0.42	1150
30	18	4.11	3.87	0.94	860	3.94	3.70	0.94	903	3.78	3.55	0.94	946	3.64	3.42	0.94	989
30	20	4.29	3.52	0.82	903	4.11	3.37	0.82	957	3.99	3.27	0.82	978	3.85	3.16	0.82	1021
30	22	4.46	3.12	0.70	935	4.31	3.01	0.70	994	4.20	2.94	0.70	1021	4.03	2.82	0.70	1064
30	24	4.69	2.72	0.58	978	4.52	2.62	0.58	1032	4.41	2.56	0.58	1064	4.27	2.48	0.58	1118
30	26	4.83	2.22	0.46	1032	4.69	2.16	0.46	1086	4.62	2.13	0.46	1118	4.48	2.06	0.46	1150
31	18	4.11	4.03	0.98	860	3.94	3.86	0.98	903	3.78	3.70	0.98	946	3.64	3.57	0.98	989
31	20	4.29	3.69	0.86	903	4.11	3.54	0.86	957	3.99	3.43	0.86	978	3.85	3.31	0.86	1021
31	22	4.46	3.30	0.74	935	4.31	3.19	0.74	994	4.20	3.11	0.74	1021	4.03	2.98	0.74	1064
31	24	4.69	2.91	0.62	978	4.52	2.80	0.62	1032	4.41	2.73	0.62	1064	4.27	2.65	0.62	1118
31	26	4.83	2.42	0.50	1032	4.69	2.35	0.50	1086	4.62	2.31	0.50	1118	4.48	2.24	0.50	1150
32	18	4.11	4.19	1.02	860	3.94	4.02	1.02	903	3.78	3.86	1.02	946	3.64	3.71	1.02	989
32	20	4.29	3.86	0.90	903	4.11	3.70	0.90	957	3.99	3.59	0.90	978	3.85	3.47	0.90	1021
32	22	4.46	3.48	0.78	935	4.31	3.36	0.78	994	4.20	3.28	0.78	1021	4.03	3.14	0.78	1064
32	24	4.69	3.10	0.66	978	4.52	2.98	0.66	1032	4.41	2.91	0.66	1064	4.27	2.82	0.66	1118
32	26	4.83	2.61	0.54	1032	4.69	2.53	0.54	1086	4.62	2.49	0.54	1118	4.48	2.42	0.54	1150

NOTE: Q : Total capacity (kW) SHF : Sensible heat factor DB : Dry-bulb temperature
 SHC : Sensible heat capacity (kW) INPUT : Total power input (W) WB : Wet-bulb temperature

PERFORMANCE DATA COOL operation at Rated frequency
MUZ-GC35VA MUZ-GC35VAH

CAPACITY:3.5(kW) SHF:0.76 INPUT:1075(W)

		OUTDOOR DB(°C)											
INDOOR DB (°C)	INDOOR WB (°C)	35				40				46			
		Q	SHC	SHF	INPUT	Q	SHC	SHF	INPUT	Q	SHC	SHF	INPUT
21	18	3.43	1.99	0.58	1054	3.15	1.83	0.58	1118	2.91	1.68	0.58	1161
21	20	3.61	1.66	0.46	1097	3.36	1.55	0.46	1150	3.12	1.43	0.46	1215
22	18	3.43	2.13	0.62	1054	3.15	1.95	0.62	1118	2.91	1.80	0.62	1161
22	20	3.61	1.80	0.50	1097	3.36	1.68	0.50	1150	3.12	1.56	0.50	1215
22	22	3.82	1.45	0.38	1140	3.57	1.36	0.38	1204	3.33	1.26	0.38	1247
23	18	3.43	2.26	0.66	1054	3.15	2.08	0.66	1118	2.91	1.92	0.66	1161
23	20	3.61	1.95	0.54	1097	3.36	1.81	0.54	1150	3.12	1.68	0.54	1215
23	22	3.82	1.60	0.42	1140	3.57	1.50	0.42	1204	3.33	1.40	0.42	1247
24	18	3.43	2.40	0.70	1054	3.15	2.21	0.70	1118	2.91	2.03	0.70	1161
24	20	3.61	2.09	0.58	1097	3.36	1.95	0.58	1150	3.12	1.81	0.58	1215
24	22	3.82	1.75	0.46	1140	3.57	1.64	0.46	1204	3.33	1.53	0.46	1247
24	24	4.03	1.37	0.34	1183	3.78	1.29	0.34	1236	3.57	1.21	0.34	1290
25	18	3.43	2.54	0.74	1054	3.15	2.33	0.74	1118	2.91	2.15	0.74	1161
25	20	3.61	2.24	0.62	1097	3.36	2.08	0.62	1150	3.12	1.93	0.62	1215
25	22	3.82	1.91	0.50	1140	3.57	1.79	0.50	1204	3.33	1.66	0.50	1247
25	24	4.03	1.53	0.38	1183	3.78	1.44	0.38	1236	3.57	1.36	0.38	1290
26	18	3.43	2.68	0.78	1054	3.15	2.46	0.78	1118	2.91	2.27	0.78	1161
26	20	3.61	2.38	0.66	1097	3.36	2.22	0.66	1150	3.12	2.06	0.66	1215
26	22	3.82	2.06	0.54	1140	3.57	1.93	0.54	1204	3.33	1.80	0.54	1247
26	24	4.03	1.69	0.42	1183	3.78	1.59	0.42	1236	3.57	1.50	0.42	1290
26	26	4.24	1.27	0.30	1226	3.99	1.20	0.30	1279	3.75	1.12	0.30	1333
27	18	3.43	2.81	0.82	1054	3.15	2.58	0.82	1118	2.91	2.38	0.82	1161
27	20	3.61	2.52	0.70	1097	3.36	2.35	0.70	1150	3.12	2.18	0.70	1215
27	22	3.82	2.21	0.58	1140	3.57	2.07	0.58	1204	3.33	1.93	0.58	1247
27	24	4.03	1.85	0.46	1183	3.78	1.74	0.46	1236	3.57	1.64	0.46	1290
27	26	4.24	1.44	0.34	1226	3.99	1.36	0.34	1279	3.75	1.27	0.34	1333
28	18	3.43	2.95	0.86	1054	3.15	2.71	0.86	1118	2.91	2.50	0.86	1161
28	20	3.61	2.67	0.74	1097	3.36	2.49	0.74	1150	3.12	2.31	0.74	1215
28	22	3.82	2.37	0.62	1140	3.57	2.21	0.62	1204	3.33	2.06	0.62	1247
28	24	4.03	2.01	0.50	1183	3.78	1.89	0.50	1236	3.57	1.79	0.50	1290
28	26	4.24	1.61	0.38	1226	3.99	1.52	0.38	1279	3.75	1.42	0.38	1333
29	18	3.43	3.09	0.90	1054	3.15	2.84	0.90	1118	2.91	2.61	0.90	1161
29	20	3.61	2.81	0.78	1097	3.36	2.62	0.78	1150	3.12	2.43	0.78	1215
29	22	3.82	2.52	0.66	1140	3.57	2.36	0.66	1204	3.33	2.19	0.66	1247
29	24	4.03	2.17	0.54	1183	3.78	2.04	0.54	1236	3.57	1.93	0.54	1290
29	26	4.24	1.78	0.42	1226	3.99	1.68	0.42	1279	3.75	1.57	0.42	1333
30	18	3.43	3.22	0.94	1054	3.15	2.96	0.94	1118	2.91	2.73	0.94	1161
30	20	3.61	2.96	0.82	1097	3.36	2.76	0.82	1150	3.12	2.55	0.82	1215
30	22	3.82	2.67	0.70	1140	3.57	2.50	0.70	1204	3.33	2.33	0.70	1247
30	24	4.03	2.33	0.58	1183	3.78	2.19	0.58	1236	3.57	2.07	0.58	1290
30	26	4.24	1.95	0.46	1226	3.99	1.84	0.46	1279	3.75	1.72	0.46	1333
31	18	3.43	3.36	0.98	1054	3.15	3.09	0.98	1118	2.91	2.85	0.98	1161
31	20	3.61	3.10	0.86	1097	3.36	2.89	0.86	1150	3.12	2.68	0.86	1215
31	22	3.82	2.82	0.74	1140	3.57	2.64	0.74	1204	3.33	2.46	0.74	1247
31	24	4.03	2.50	0.62	1183	3.78	2.34	0.62	1236	3.57	2.21	0.62	1290
31	26	4.24	2.12	0.50	1226	3.99	2.00	0.50	1279	3.75	1.87	0.50	1333
32	18	3.43	3.50	1.02	1054	3.15	3.21	1.02	1118	2.91	2.96	1.02	1161
32	20	3.61	3.24	0.90	1097	3.36	3.02	0.90	1150	3.12	2.80	0.90	1215
32	22	3.82	2.98	0.78	1140	3.57	2.78	0.78	1204	3.33	2.59	0.78	1247
32	24	4.03	2.66	0.66	1183	3.78	2.49	0.66	1236	3.57	2.36	0.66	1290
32	26	4.24	2.29	0.54	1226	3.99	2.15	0.54	1279	3.75	2.02	0.54	1333

NOTE: Q : Total capacity (kW) SHF : Sensible heat factor DB : Dry-bulb temperature
 SHC : Sensible heat capacity (kW) INPUT : Total power input (W) WB : Wet-bulb temperature

PERFORMANCE DATA HEAT operation at Rated frequency

MUZ-GC25VA MUZ-GC25VAH

CAPACITY:3.2(kW) INPUT:835(W)

INDOOR DB(°C)	OUTDOOR WB(°C)													
	-10		-5		0		5		10		15		20	
	Q	INPUT	Q	INPUT	Q	INPUT	Q	INPUT	Q	INPUT	Q	INPUT	Q	INPUT
15	2.02	543	2.43	651	2.85	735	3.26	793	3.68	843	4.06	868	4.48	885
21	1.92	585	2.30	693	2.72	768	3.10	827	3.52	868	3.90	893	4.30	927
26	1.73	626	2.14	735	2.53	810	2.94	868	3.36	910	3.74	935	4.16	960

MUZ-GC35VA MUZ-GC35VAH

CAPACITY:4.0(kW) INPUT:1055(W)

INDOOR DB(°C)	OUTDOOR WB(°C)													
	-10		-5		0		5		10		15		20	
	Q	INPUT	Q	INPUT	Q	INPUT	Q	INPUT	Q	INPUT	Q	INPUT	Q	INPUT
15	2.52	686	3.04	823	3.56	928	4.08	1002	4.60	1066	5.08	1097	5.60	1118
21	2.40	739	2.88	876	3.40	971	3.88	1044	4.40	1097	4.88	1129	5.38	1171
26	2.16	791	2.68	928	3.16	1023	3.68	1097	4.20	1150	4.68	1182	5.20	1213

NOTE: Q:Total capacity (kW) INPUT:Total power input (W) DB : Dry-bulb temperature WB : Wet-bulb temperature

MUZ-GC25VA MUZ-GC35VA
MUZ-GC25VAH MUZ-GC35VAH

9-1. Outdoor fan motor control

The fan motor turns ON/OFF, interlocking with the compressor.

[ON] The fan motor turns ON 5 seconds before the compressor starts up.

[OFF] The fan motor turns OFF 15 seconds after the compressor has stopped running.

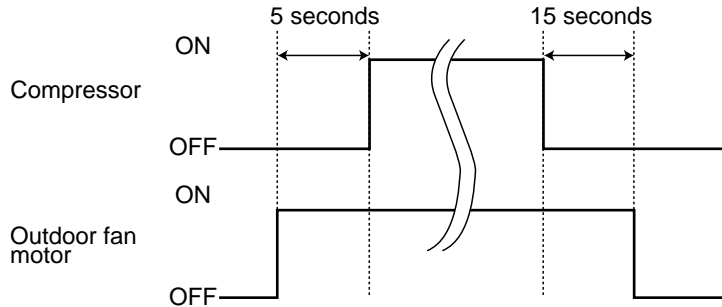

9-2. R.V. coil control

- Heating ON
- Cooling OFF
- Dry OFF

NOTE: The 4-way valve reverses for 5 seconds right before start-up of the compressor.

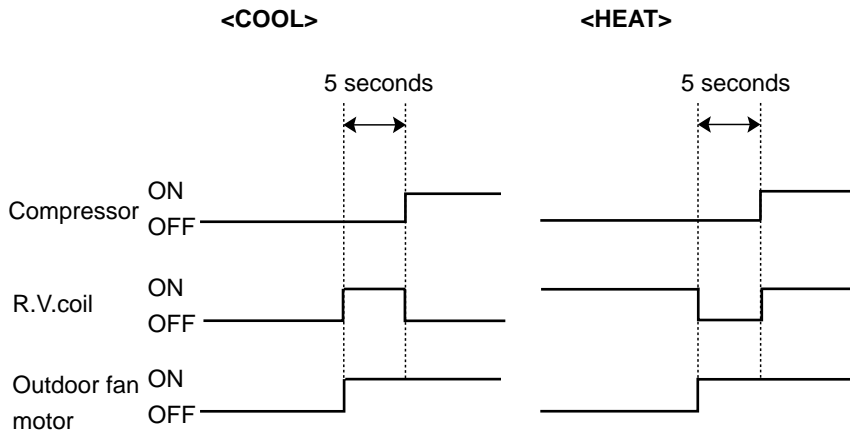

9-3. Relation between main sensor and actuator

Sensor	Purpose	Actuator					
		Compressor	LEV	Outdoor fan motor	R.V. coil	Indoor fan motor	Defrost heater
Discharge temperature thermistor	Protection	○	○				
Indoor coil temperature thermistor	Cooling : Coil frost prevention	○	○				
	Heating : High pressure protection	○	○				
Defrost thermistor	Cooling : High pressure protection	○	○				
	Heating : Defrosting	○	○	○	○	○	
Fin temperature thermistor	Protection	○	○	○ ※1			
Ambient temperature thermistor	Cooling : Low outside temperature operation	○	○	○			
	Heating : Defrosting (Heater)						○

※1 MUZ-GC35VA
 MUZ-GC35VAH

10

SERVICE FUNCTIONS

MUZ-GC25VA
MUZ-GC25VAH

MUZ-GC35VA
MUZ-GC35VAH

10-1. CHANGE IN DEFROST SETTING

<JS> When the JS wire of the outdoor Inverter P.C. board is cut/ soldered, the defrost finish temperature is changed.
(Refer to 11-6-1.)

Jumper wire		Defrost finish temperature (°C)	
		MUZ-GC25VA MUZ-GC35VA	MUZ-GC25VAH MUZ-GC35VAH
JS	soldered (Initial setting)	5	8
	none (cut)	8	15

10-2. PRE-HEAT CONTROL SETTING

PRE-HEAT CONTROL

When moisture gets into the refrigerant cycle, it may interfere the start-up of the compressor at low outside temperature. The pre-heat control prevents this interference. The pre-heat control turns ON when outside temperature is 20°C or below. When pre-heat control is turned ON, compressor is energized. (about 50 W)

MUZ-GC25 <JK> When the JK wire of the inverter P.C. board is cut, pre-heat control is activated.(Refer to 11-6.1)
MUZ-GC35 Inverter P.C.board needs to be changed.

NOTE: When the inverter P.C. board is replaced, check the Jumper wires, and cut/solder them if necessary.

11

TROUBLESHOOTING

MUZ-GC25VA
MUZ-GC25VAH

MUZ-GC35VA
MUZ-GC35VAH

11-1. Cautions on troubleshooting

1. Before troubleshooting, check the following:

- 1) Check the power supply voltage.
- 2) Check the indoor/outdoor connecting wire for mis-wiring.

2. Take care of the following during servicing

- 1) Before servicing the air conditioner, be sure to turn OFF the main unit first with the remote controller, and then after confirming the horizontal vane is closed, turn OFF the breaker and / or disconnect the power plug.
- 2) Be sure to turn OFF the power supply before removing the front panel, the cabinet, the top panel, and the electronic control P.C. board.
- 3) When removing the electrical parts, be careful to the residual voltage of smoothing capacitor.
- 4) When removing the electronic control P.C. board, hold the edge of the board with care NOT to apply stress on the components.
- 5) When connecting or disconnecting the connectors, hold the housing of the connector. DO NOT pull the lead wires.

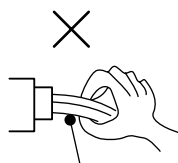

Lead wiring

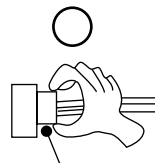

Housing point

3. Troubleshooting procedure

- 1) First, check if the OPERATION INDICATOR lamp on the indoor unit is flashing on and off to indicate an abnormality. To make sure, check how many times the abnormality indication is flashing on and off before starting service work.
- 2) Before servicing check that the connector and terminal are connected properly.
- 3) If the electronic control P.C. board is supposed to be defective, check the copper foil pattern for disconnection and the components for bursting and discoloration.
- 4) Refer to 11-2. and 11-3.

11-2. Failure mode recall function

Outline of the function

This air conditioner can memorize the abnormal condition which has occurred once.

Even though LED indication listed on the troubleshooting check table (11-4.) disappears, the memorized failure details can be recalled.

This mode is very useful when the unit needs to be repaired for the abnormality which doesn't recur.

1. Flow chart of failure mode recall function for the indoor/outdoor unit

Operational procedure

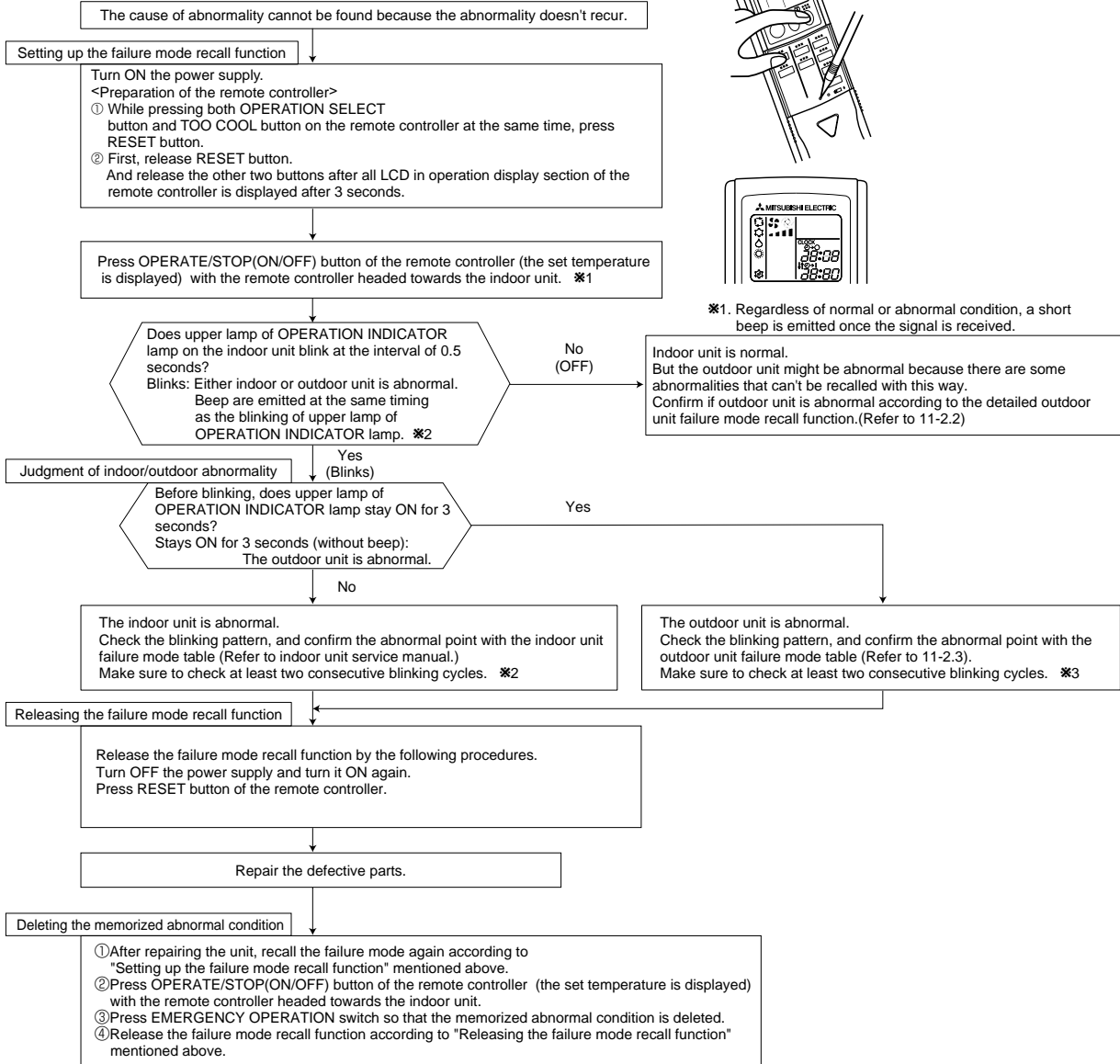

NOTE: 1. Make sure to release the failure mode recall function once it's set up, otherwise the unit cannot operate properly.
2. If the abnormal condition is not deleted from the memory, the last abnormal condition is kept memorized.

※2. Blinking pattern when the indoor unit is abnormal:

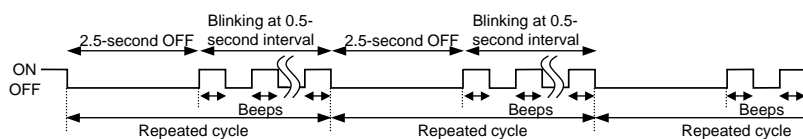

※3. Blinking pattern when the outdoor unit is abnormal:

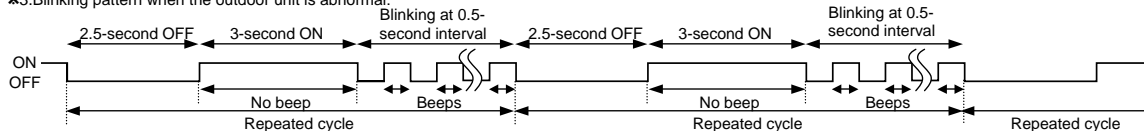

2. Flow chart of the detailed outdoor unit failure mode recall function

Operational procedure

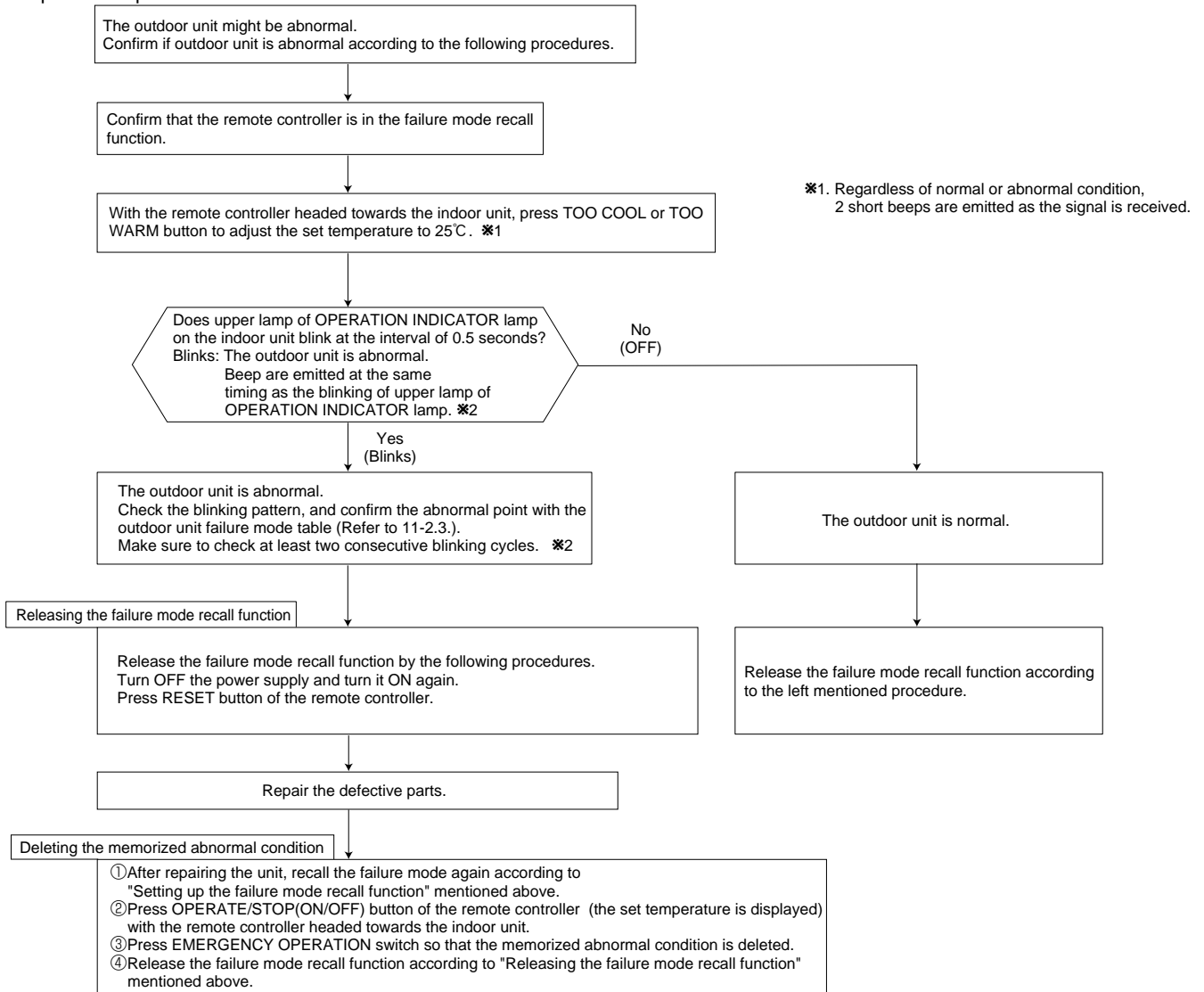

NOTE: 1. Make sure to release the failure mode recall function once it's set up, otherwise the unit cannot operate properly.
2. If the abnormal condition is not deleted from the memory, the last abnormal condition is kept memorized.

※2. Blinking pattern when outdoor unit is abnormal:

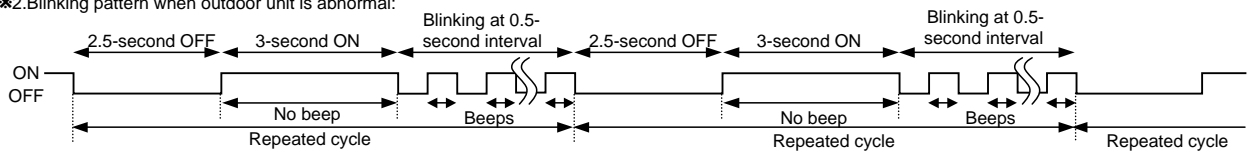

3. Outdoor unit failure mode table

The upper lamp of OPERATION INDICATOR lamp(Indoor unit)	Abnormal point (Failure mode / protection)	LED indication (Outdoor P.C. board)	Condition	Correspondence	Indoor/outdoor unit failure mode recall function	Outdoor unit failure mode recall function
OFF	None (Normal)	—	—	—	—	—
2-time flash 2.5 seconds OFF	Outdoor power system	—	Over current protection stop is continuously performed three times within 1 minute after the compressor gets started.	<ul style="list-style-type: none"> •Reconnect connectors. •Refer to 11-5. Ⓐ) "How to check inverter/compressor". •Check stop valve. 	○	○
3-time flash 2.5 seconds OFF	Discharge temperature thermistor	1-time flash every 2.5 seconds	Thermistor shorts or opens during compressor running.	<ul style="list-style-type: none"> •Refer to 11-5. Ⓒ) "Check of outdoor thermistors". ※Defective outdoor thermistors can be identified by checking the blinking pattern of LED. 	○	○
	Defrost thermistor	3-time flash 2.5 seconds OFF				
	Fin temperature thermistor	4-time flash 2.5 seconds OFF				
	P.C. board temperature thermistor	2-time flash 2.5 seconds OFF				
4-time flash 2.5 seconds OFF	Overcurrent	11-time flash 2.5 seconds OFF	14 A (MUZ-GC25)/24 A (MUZ-GC35) current flow into intelligent power module.	<ul style="list-style-type: none"> •Reconnect compressor connector. •Refer to 11-5. Ⓐ) "How to check inverter/compressor". •Check stop valve. 	—	○
	Compressor synchronous abnormality (Compressor start-up failure protection)	12-time flash 2.5 seconds OFF	Waveform of compressor current is distorted.	<ul style="list-style-type: none"> •Reconnect compressor connector. •Refer to 11-5. Ⓐ) "How to check inverter/compressor". 	—	○
5-time flash 2.5 seconds OFF	Discharge temperature	—	Temperature of discharge temperature thermistor exceeds 116°C, compressor stops. Compressor can restart if discharge temperature thermistor reads 100°C or less 3 minutes later.	<ul style="list-style-type: none"> •Check refrigerant circuit and refrigerant amount. •Refer to 11-5. Ⓓ) "Check of LEV". 	—	○
6-time flash 2.5 seconds OFF	High pressure	—	Temperature indoor coil thermistor exceeds 70°C in HEAT mode. Temperature defrost thermistor exceeds 70°C in COOL mode.	<ul style="list-style-type: none"> •Check refrigerant circuit and refrigerant amount. •Check stop valve. 	—	○
7-time flash 2.5 seconds OFF	Fin temperature/ P.C. board temperature	7-time flash 2.5 seconds OFF	Temperature of fin temperature thermistor on the inverter P.C. board exceeds 82°C (MUZ-GC25)/83°C (MUZ-GC35), or temperature of P.C. board temperature thermistor on the inverter P.C. board exceeds 81°C (MUZ-GC25)/85°C (MUZ-GC35).	<ul style="list-style-type: none"> •Check around outdoor unit. •Check outdoor unit air passage. •Refer to 11-5. ①) "Check of outdoor fan motor". 	—	○
8-time flash 2.5 seconds OFF	Outdoor fan motor	—	Outdoor fan has stopped 3 times in a row within 30 seconds after outdoor fan start-up.	<ul style="list-style-type: none"> •Refer to 11-5. ①) "Check of outdoor fan motor". Refer to 11-5. Ⓜ) "Check of inverter P.C. board". 	—	○
9-time flash 2.5 seconds OFF	Nonvolatile memory data	5-time flash 2.5 seconds OFF	Nonvolatile memory data cannot be read properly.	<ul style="list-style-type: none"> •Replace the inverter P.C. board. 	○	○
10-time flash 2.5 seconds OFF	Discharge temperature	—	Temperature of discharge temperature thermistor has been 50°C or less for 20 minutes.	<ul style="list-style-type: none"> •Refer to 11-5. Ⓓ) "Check of LEV". •Check refrigerant circuit and refrigerant amount. 	—	○
11-time flash 2.5 seconds OFF	DC voltage	8-time flash 2.5 seconds OFF	DC voltage of inverter cannot be detected normally.	<ul style="list-style-type: none"> •Refer to 11-5. Ⓐ) "How to check inverter/compressor". 	—	○
	Each phase current of compressor	9-time flash 2.5 seconds OFF	Each phase current of compressor cannot be detected normally.			
12-time flash 2.5 seconds OFF	Overcurrent Compressor open-phase	10-time flash 2.5 seconds OFF	14 A (MUZ-GC25) / 24 A (MUZ-GC35) current flow into intelligent power module (IPM). The open-phase operation of compressor is detected. The interphase short out occurs in the output of the intelligent power module (IPM). The compressor winding shorts out.	<ul style="list-style-type: none"> •Reconnect compressor connector. •Refer to 11-5. Ⓐ) "How to check inverter/compressor". 	—	○
14-time flash 2.5 seconds OFF	Stop valve (Closed valve)	14-time flash 2.5 seconds OFF	Closed valve is detected by compressor current.	<ul style="list-style-type: none"> •Check stop valve 	○	○

NOTE: Blinking patterns of this mode differ from the ones of Troubleshooting check table (11-3.).

11-3. Troubleshooting check table

No.	Symptom	LED indication	Abnormal point/ Condition	Condition	Correspondence	
1	Outdoor unit does not operate.	1-time flash every 2.5 seconds	Outdoor power system	Over current protection stop is continuously performed three times within 1 minute after the compressor gets started, or failure of restart of compressor has repeated 24 times.	<ul style="list-style-type: none"> Reconnect connector of compressor. Refer to 11-5.③ "How to check inverter/ compressor". Check stop valve. 	
2			Outdoor thermistors	Discharge temperature thermistor, fin temperature thermistor, defrost thermistor, P.C. board temperature thermistor or ambient temperature thermistor shorts or opens during compressor running.	Refer to 11-5.④ "Check of outdoor thermistors".	
3			Outdoor control system	Nonvolatile memory data cannot be read properly. (When the upper lamp of OPERATION INDICATOR lamp of the indoor unit lights up or flashes 7-time.)	Replace inverter P.C. board.	
4		6-time flash 2.5 seconds OFF	Serial signal	The communication fails between the indoor and outdoor unit for 3 minutes.	Refer to 11-5.⑤ "How to check mis-wiring and serial signal error".	
5		11-time flash 2.5 seconds OFF	Stop valve/ Closed valve	Closed valve is detected by compressor current.	Check stop valve.	
6		14-time flash 2.5 seconds OFF	Outdoor unit (Other abnormality)	Outdoor unit is defective.	Refer to 11-2.2. "Flow chart of the detailed outdoor unit failure mode recall function".	
7	'Outdoor unit stops and restarts 3 minutes later' is repeated.	2-time flash 2.5 seconds OFF	Overcurrent protection	14 A (MUZ-GC25)/ 24 A (MUZ-GC35) current flows into intelligent power module, or compressor repeats after 15 seconds when overcurrent protection occurs with in 10 seconds after compressor starts. (Repeated 24 times at Maximum)	<ul style="list-style-type: none"> Reconnect connector of compressor. Refer to 11-5.③ "How to check inverter/compressor". Check stop valve. 	
8		3-time flash 2.5 seconds OFF	Discharge temperature overheat protection	Temperature of discharge temperature thermistor exceeds 116°C, compressor stops. Compressor can restart if discharge temperature thermistor reads 100°C or less 3 minutes later.	<ul style="list-style-type: none"> Check refrigerant circuit and refrigerant amount. Refer to 11-5.④ "Check of LEV". 	
9		4-time flash 2.5 seconds OFF	Fin temperature /P.C. board temperature thermistor overheat protection	Temperature of fin temperature thermistor on the heat sink exceeds 82°C (MUZ-GC25)/ 83°C (MUZ-GC35) or temperature of P.C. board temperature thermistor on the inverter P.C.board exceeds 81°C (MUZ-GC25)/ 85°C (MUZ-GC35).	<ul style="list-style-type: none"> Check around outdoor unit. Check outdoor unit air passage. Refer to 11-5.④ "Check of outdoor fan motor". 	
10		5-time flash 2.5 seconds OFF	High pressure protection	Indoor coil thermistor exceeds 70°C in HEAT mode. Defrost thermistor exceeds 70°C in COOL mode.	<ul style="list-style-type: none"> Check refrigerant circuit and refrigerant amount. Check stop valve. 	
11		8-time flash 2.5 seconds OFF	Compressor synchronous abnormality	The waveform of compressor current is distorted.	<ul style="list-style-type: none"> Reconnect connector of compressor. Refer to 11-5.③ "How to check inverter/compressor". 	
12		10-time flash 2.5 seconds OFF	Outdoor fan motor	Outdoor fan has stopped 3 times in a row within 30 seconds after outdoor fan start-up.	<ul style="list-style-type: none"> Refer to 11-5.① "Check of outdoor fan motor". Refer to 11-5.⑤ "Check of inverter P.C. board". 	
13		12-time flash 2.5 seconds OFF	Each phase current of compressor	Each phase current of compressor cannot be detected normally	Refer to 11-5.⑤ "How to check inverter/compressor".	
14		13-time flash 2.5 seconds OFF	DC voltage	DC voltage of inverter cannot be detected normally.	Refer to 11-5.⑤ "How to check inverter/compressor".	
15		Outdoor unit operates.	1-time flash 2.5 seconds OFF	Frequency drop by current protection	Current from power outlet exceeds 5.5 A (MUZ-GC25)/ 5.2 A (MUZ-GC35 in COOL mode)/6.1 A (MUZ-GC35 in HEAT mode), compressor frequency lowers.	The unit is normal, but check the following. <ul style="list-style-type: none"> Check if indoor filters are clogged. Check if refrigerant is short. Check if indoor/outdoor unit air circulation is short cycled.
16			3-time flash 2.5 seconds OFF	Frequency drop by high pressure protection	Temperature of indoor coil thermistor exceeds 55°C in HEAT mode, compressor frequency lowers.	
17	4-time flash 2.5 seconds OFF		Frequency drop by defrosting in COOL mode	Indoor coil thermistor reads 8°C or less in COOL mode, compressor frequency lowers.		
18	Outdoor unit operates.	7-time flash 2.5 seconds OFF	Low discharge temperature protection	Temperature of discharge temperature thermistor has been 50°C or less for 20 minutes.	<ul style="list-style-type: none"> Refer to 11-5.④ "Check of LEV". Check refrigerant circuit and refrigerant amount. 	
19		8-time flash 2.5 seconds OFF	PAM protection	The overcurrent flows into IGBT(Insulated Gate Bipolar transistor : TR821) or when the bus-bar voltage reaches 320 V or more, PAM stops and restarts.	This is not malfunction. PAM protection will be activated in the following cases: <ul style="list-style-type: none"> ① Instantaneous power voltage drop (Short time power failure) ② When the power supply voltage is high. 	
20		9-time flash 2.5 seconds OFF	Inverter check mode	The connector of compressor is disconnected, inverter check mode starts.	Check if the connector of the compressor is correctly connected. Refer to 11-5.⑤ "How to check inverter/ compressor".	

NOTE: 1. The location of LED is illustrated at the right figure. Refer to 11-6.1.
2. LED is lighted during normal operation.

The flashing frequency shows the number of times the LED blinks after every 2.5-second OFF.
(Example) When the flashing frequency is "2".

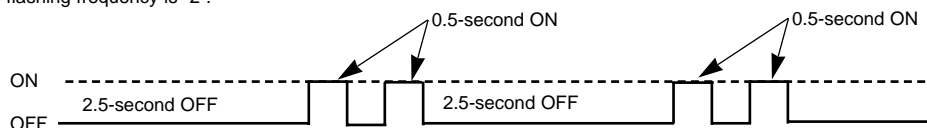

Inverter P.C. board (Parts side)

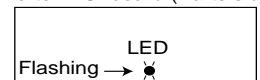

11-4. Trouble criterion of main parts

MUZ-GC25VA
MUZ-GC25VAH

MUZ-GC35VA
MUZ-GC35VAH

Part name	Check method and criterion	Figure									
Defrost thermistor (RT61)	Measure the resistance with a tester.										
Ambient temperature thermistor (RT65)	Refer to 11-7. "Test point diagram and voltage", 1. "Inverter P.C. board", the chart of thermistor.										
Discharge temperature thermistor (RT62)	Measure the resistance with a tester. Before measurement, hold the thermistor with your hands to warm it up.										
Fin temperature thermistor (RT64)	Refer to 11-7. "Test point diagram and voltage", 1. "Inverter P.C. board", the chart of thermistor.										
Compressor (MC)	Measure the resistance between the terminals with a tester. (Part temperature $-20^{\circ}\text{C} \sim 40^{\circ}\text{C}$)										
	<table border="1"> <thead> <tr> <th rowspan="2"></th> <th colspan="2">Normal</th> </tr> <tr> <th>MUZ-GC25</th> <th>MUZ-GC35</th> </tr> </thead> <tbody> <tr> <td>U-V</td> <td rowspan="3">1.58 Ω ~ 2.03 Ω</td> <td rowspan="3">1.43 Ω ~ 1.84 Ω</td> </tr> <tr> <td>U-W</td> </tr> <tr> <td>V-W</td> </tr> </tbody> </table>			Normal		MUZ-GC25	MUZ-GC35	U-V	1.58 Ω ~ 2.03 Ω	1.43 Ω ~ 1.84 Ω	U-W
	Normal										
	MUZ-GC25	MUZ-GC35									
U-V	1.58 Ω ~ 2.03 Ω	1.43 Ω ~ 1.84 Ω									
U-W											
V-W											
Outdoor fan motor (MF) INNER FUSE (Only MUZ-GC25) RA6V21-AB 152 $^{+0}_{-5}$ $^{\circ}\text{C}$ CUT OFF RA6V21-BB 126 \pm 2 $^{\circ}\text{C}$ CUT OFF	Measure the resistance between the terminals with a tester. (Part temperature $-20^{\circ}\text{C} \sim 40^{\circ}\text{C}$)										
R.V. coil (21S4)	Measure the resistance between the terminals with a tester. (Part temperature $-20^{\circ}\text{C} \sim 40^{\circ}\text{C}$)										
Expansion valve coil (LEV)	Measure the resistance with a tester. (Part temperature $-20^{\circ}\text{C} \sim 40^{\circ}\text{C}$)										
Defrost heater (H)	Measure the resistance with a tester. (Part temperature $-20^{\circ}\text{C} \sim 40^{\circ}\text{C}$)										

11-5. Troubleshooting flow

When OPERATION INDICATOR lamp flashes 5-times.
Outdoor unit does not operate.

A How to check inverter/ compressor

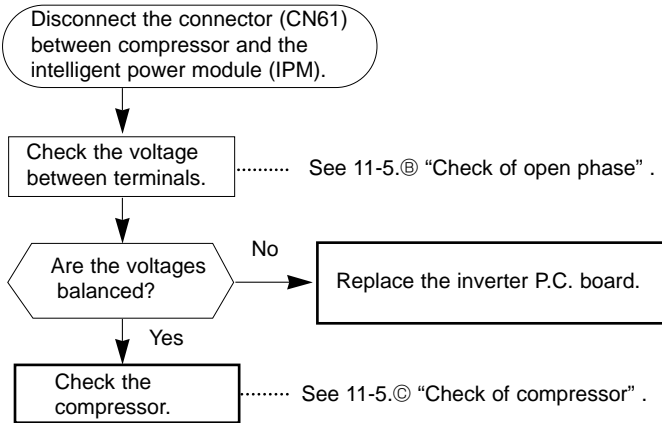

B Check of open phase

- With the connector between the compressor and the intelligent power module disconnected, activate the inverter and check if the inverter is normal by measuring the balance of voltage between the terminals.

Output voltage 115V

<< Operation method >>

Start cooling or heating operation by pressing EMERGENCY OPERATION switch on the indoor unit. (Test run operation : refer to 8-3.)

<< Measurement point >>

at 3 points

BLK (U)-WHT (V)

BLK (U)-RED (W)

WHT(V)-RED (W)

※ Measure AC voltage between the lead wires at 3 points.

9-time flash



- NOTE:** 1. Output voltage varies according to power supply voltage.
2. Measure the voltage by analog type tester.
3. During this check, LED of inverter P.C. board flashes 9 times. (Refer to 11-6.1.)

C Check of compressor

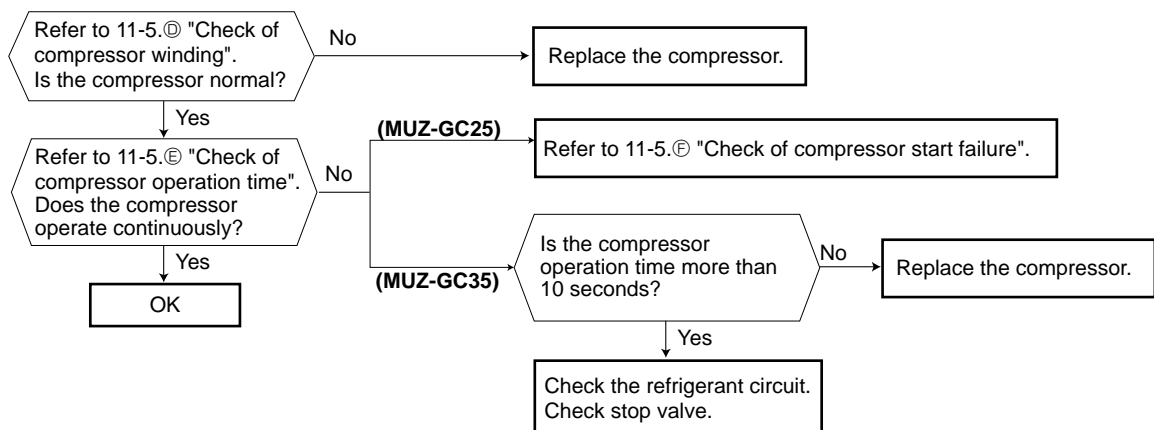

D Check of compressor winding

- Disconnect the connector (CN61) between the compressor and intelligent power module, and measure the resistance between the compressor terminals.

<<Measurement point>>

at 3 points

BLK-WHT

BLK-RED

WHT-RED

* Measure the resistance between the lead wires at 3 points.

<<Judgement>>

Refer to 11-4.

0[Ω]Abnormal [short]

Infinite[Ω]Abnormal [open]

NOTE: 1. Be sure to zero the ohmmeter before measurement.

2. Winding resistance for each phase at 20°C.

Refer to 3.SPECIFICATION.

E Check of compressor operation time

- Connect the compressor and activate the inverter. Then measure the time until the inverter stops due to over current.

<<Operation method>>

Start heating or cooling operation by pressing EMERGENCY

OPERATION switch on the indoor unit.

(Test run operation : Refer to 8-3.)

<<Measurement>>

Measure the time from the start of compressor to the stop of compressor due to over current.

<<Judgement>>

For reference

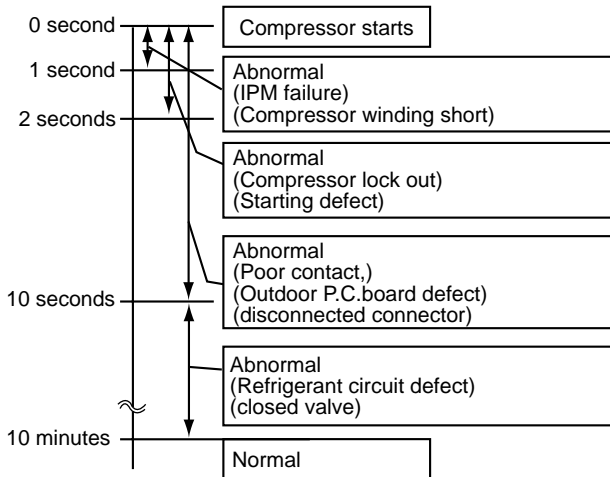

F Check of compressor start failure

Confirm that 1~5 is normal.

•Electrical circuit check

①Contact of the compressor connector (including CN61)

②Output voltage of inverter P.C.board and balance of them (See 11-5.③)

③Direct current voltage between DB61(+) and (-) on inverter P.C.board

④Voltage between outdoor terminal block S1-S2

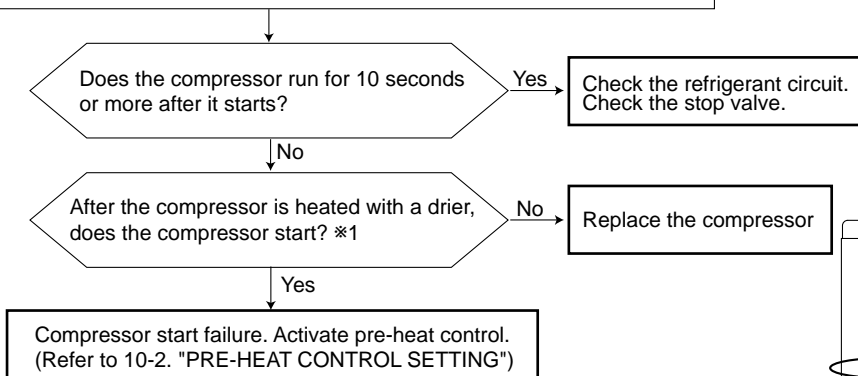

*1
Heat with a drier for about 20 minutes.
Do not recover refrigerant gas while heating compressor with a drier.

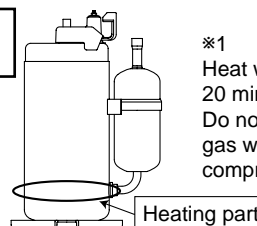

**When OPERATION INDICATOR lamp flashes 6-time.
The thermistors in the outdoor unit are abnormal.**

G Check of outdoor thermistors

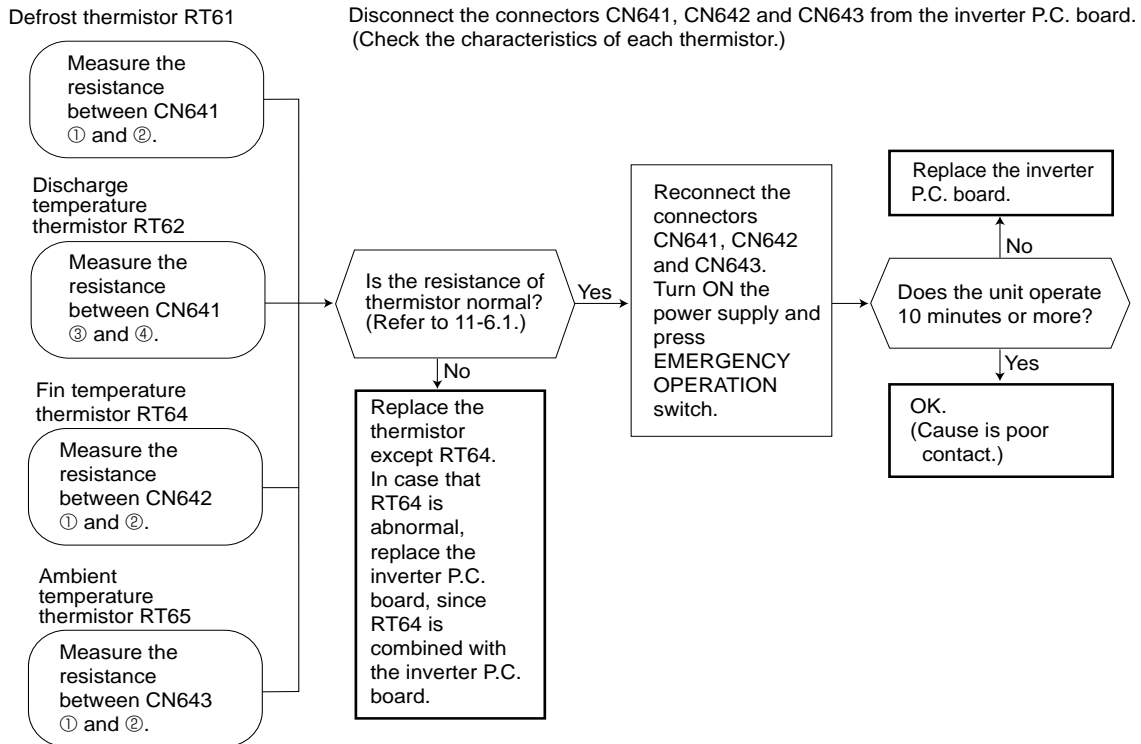

H Check of R.V. coil

- * First of all, measure the resistance of R.V. coil to check if the coil is defective. Refer to 11-4.
- * In case CN721 is not connected or R.V. coil is open, voltage is generated between the terminal pins of the connector although any signal is not being transmitted to R.V. coil. Check if CN721 is connected.

Unit operates COOL mode even if it is set to HEAT mode.

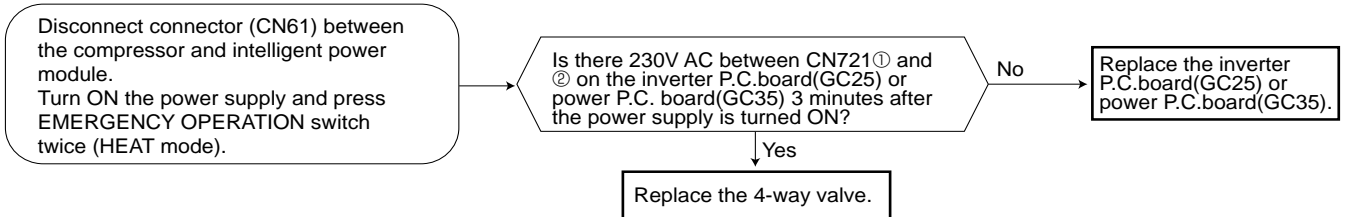

Unit operates HEAT mode even if it is set to COOL mode.

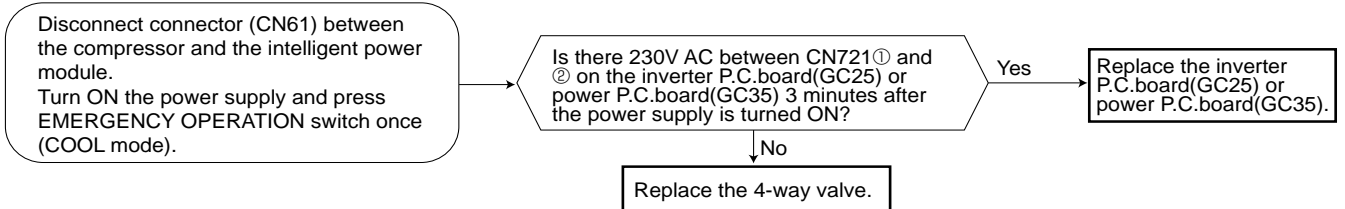

MUZ-GC25

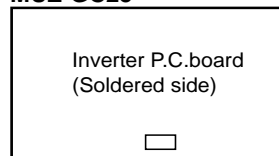

MUZ-GC35

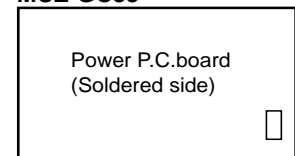

Outdoor fan motor does not operate.

① Check of outdoor fan motor

MUZ-GC25VA MUZ-GC25VAH

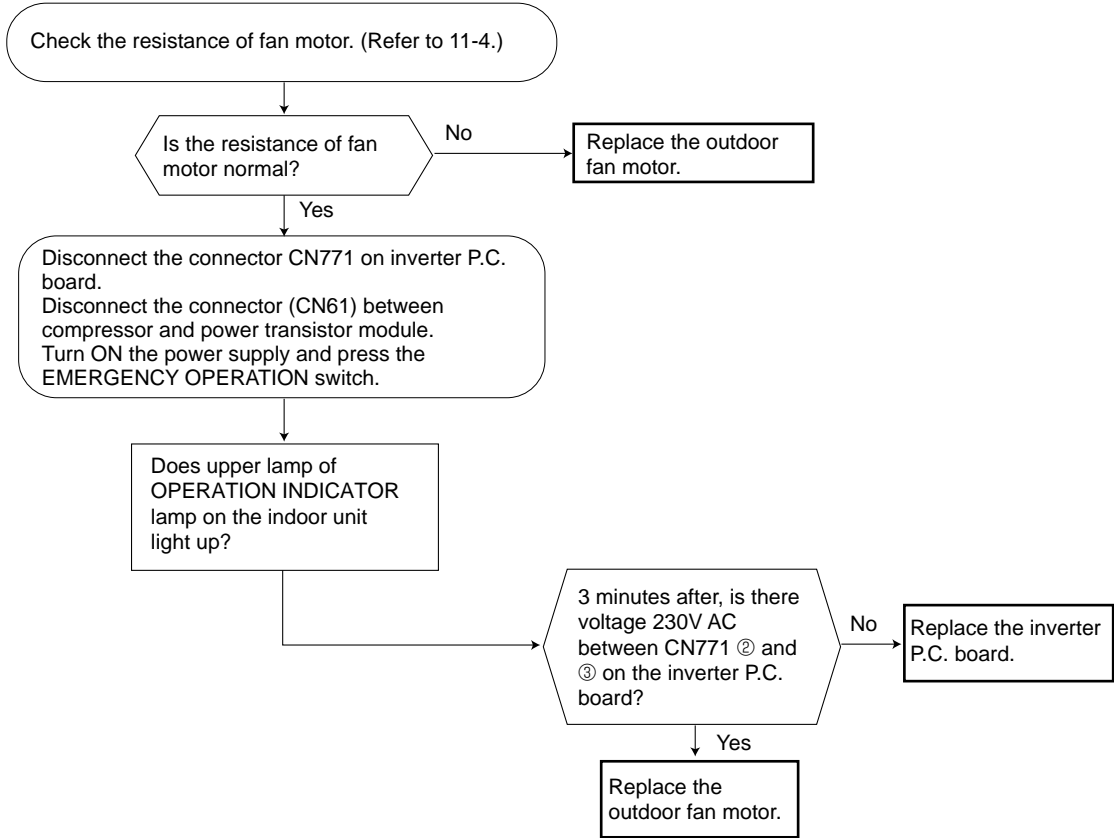

MUZ-GC35VA MUZ-GC35VAH

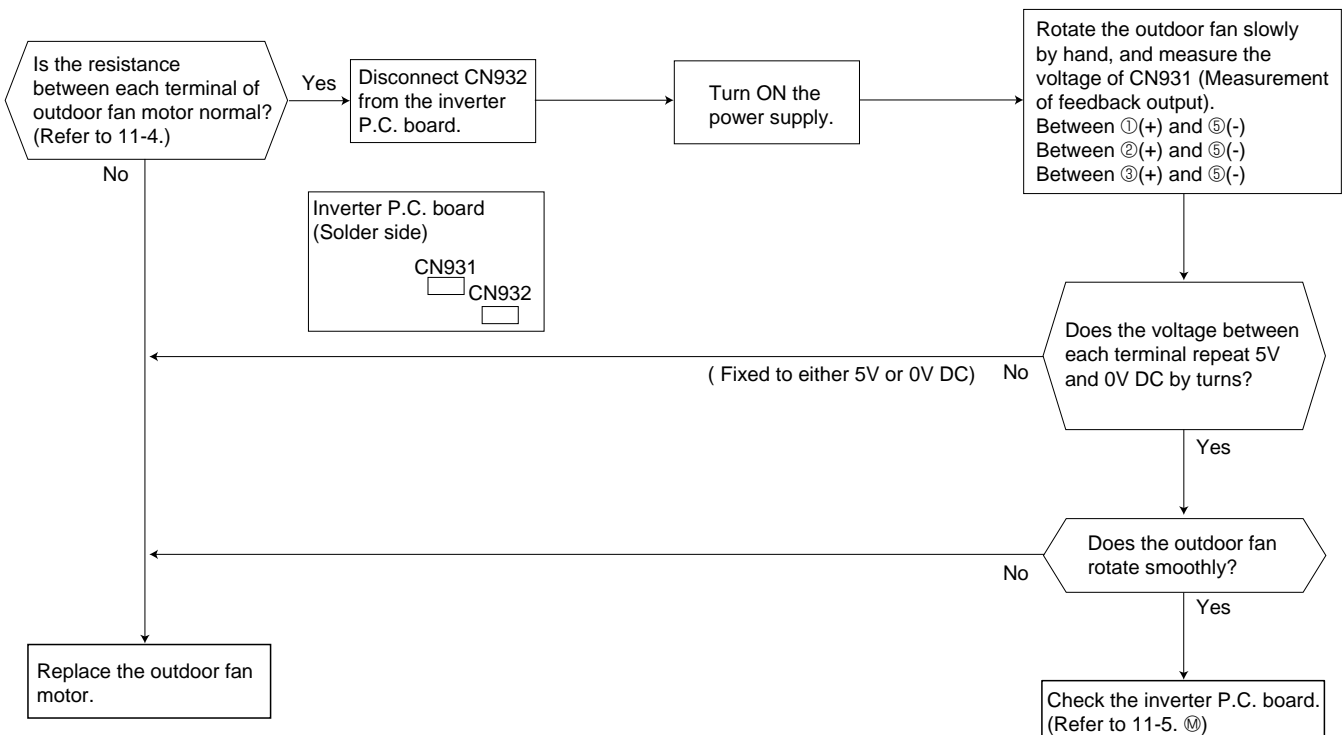

Inverter does not operate.

J Check of power supply

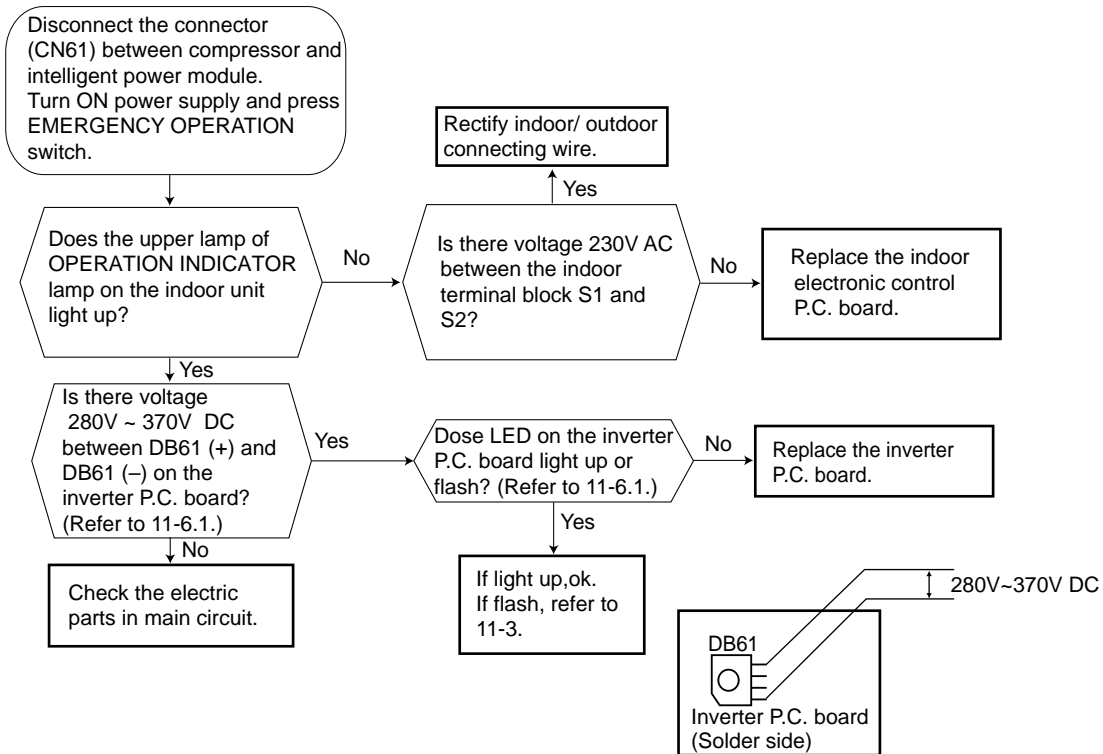

Outdoor unit does not operate at all, or stops immediately due to overcurrent.

K Check of current-limiting resistor

MUZ-GC35VA MUZ-GC35VAH

When the current-limiting resistor is open, the rush current limiting relay (X64) may not work properly.

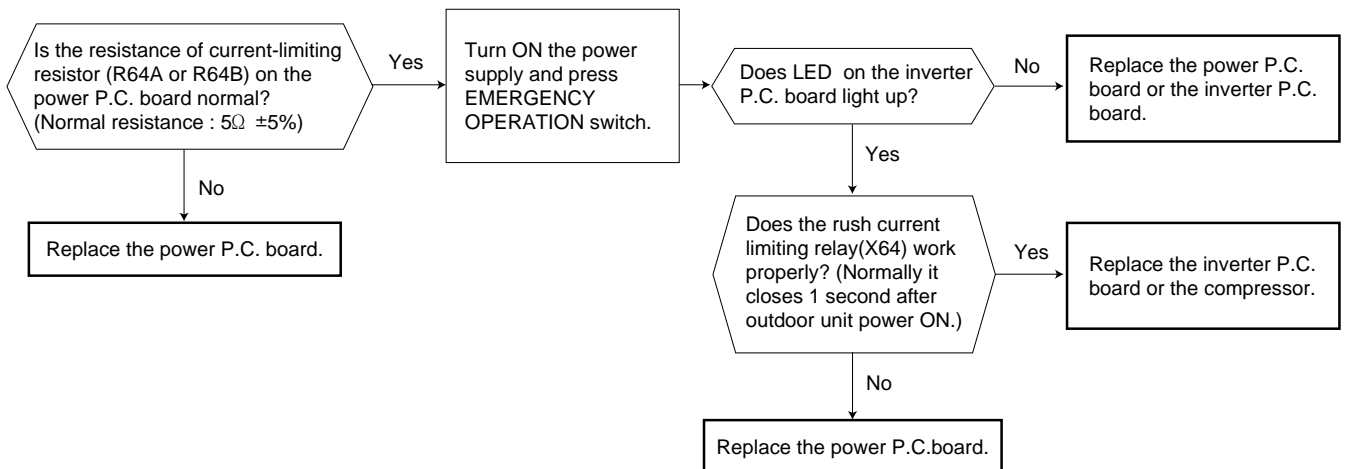

● Check other electric parts in the main circuit together in the case that the current-limiting resistor is defective.

Heating/Cooling does not work sufficiently.

Ⓐ Check of LEV (Expansion valve)

Turn ON the power supply.
 <Preparation of the remote controller>
 ① While pressing both OPERATION SELECT button and TOO COOL button on the remote controller at the same time, press RESET button.
 ② First, release RESET button.
 And release the other two buttons after all LCD except the set temperature in operation display section of the remote controller is displayed after 3 seconds.

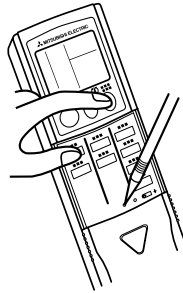

Press OPERATE/STOP(ON/OFF) button of the remote controller (the set temperature is displayed) with the remote controller headed towards the indoor unit. ※1

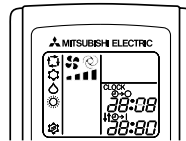

※1. Regardless of normal or abnormal condition, a short beep is emitted once the signal is received.

Expansion valve operates in full-opening direction.

Do you hear the expansion valve "click, click....." ?
 Do you feel the expansion valve vibrate on touching it ?

Yes → OK

No

Is LEV properly fixed to the expansion valve?

No → Properly fix the LEV to the expansion valve.

Yes

Does the resistance of LEV have the characteristics? (Refer to 11-4.)

Yes → Measure each voltage between connector pins of CN724 on the inverter P.C. board.

Measure each voltage between connector pins of CN724 on the inverter P.C. board.

1. Pin③(-) – Pin①(+)
2. Pin④(-) – Pin①(+)
3. Pin⑤(-) – Pin①(+)
4. Pin⑥(-) – Pin①(+)

Is there about 3~5V AC between each?
 NOTE: Measure the voltage by an analog tester.

No → Replace the inverter P.C. board.

No → Replace the LEV.

Yes → Replace the expansion valve.

NOTE : After check of LEV, do the undermentioned operations.

1. Turn OFF the power supply and turn ON it again.
2. Press RESET button on the remote controller.

Outdoor fan motor does not operate , or stops immediately after starting up.

M Check of inverter P.C. board

MUZ-GC35VA MUZ-GC35VAH

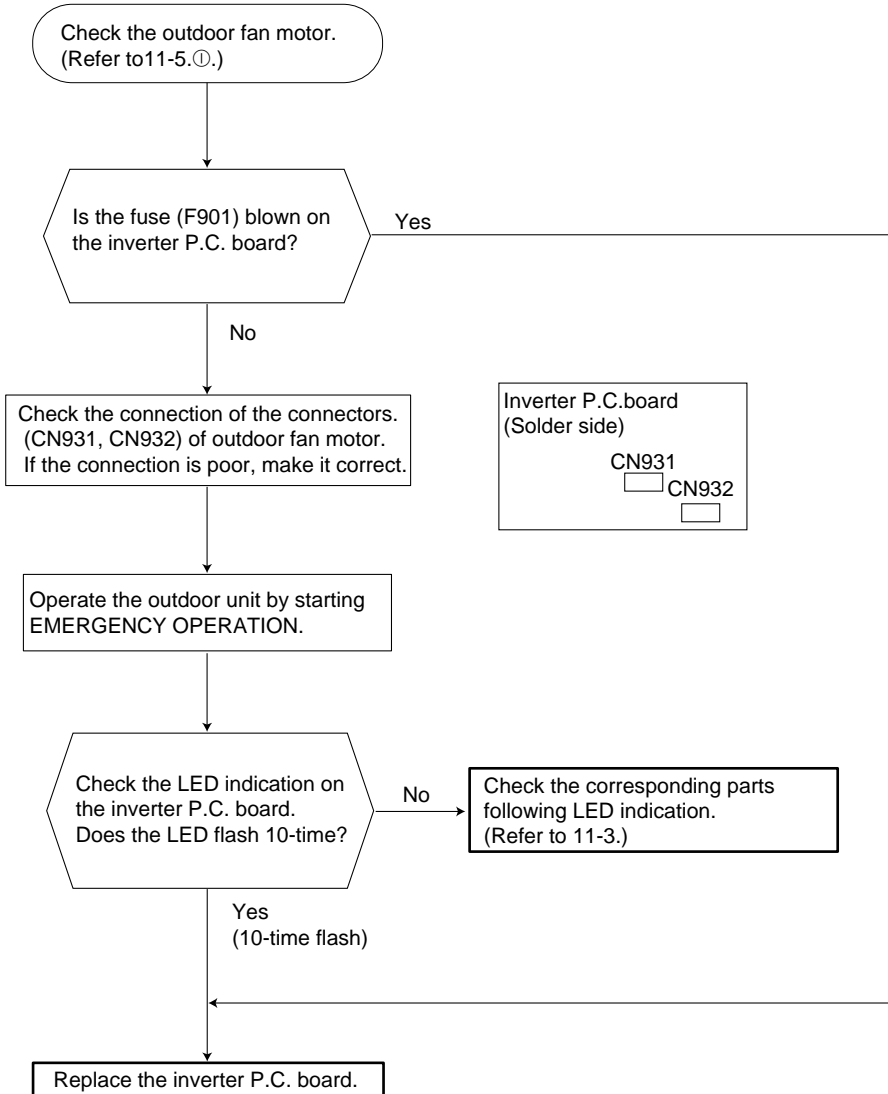

- When unit cannot operate neither by the remote controller nor by EMERGENCY OPERATION switch. Indoor unit does not operate.
- When OPERATION INDICATOR lamp flashes ON and OFF in every 0.5-seconds. Outdoor unit doesn't operate.

(N) How to check mis-wiring and serial signal error (when outdoor unit does not work)

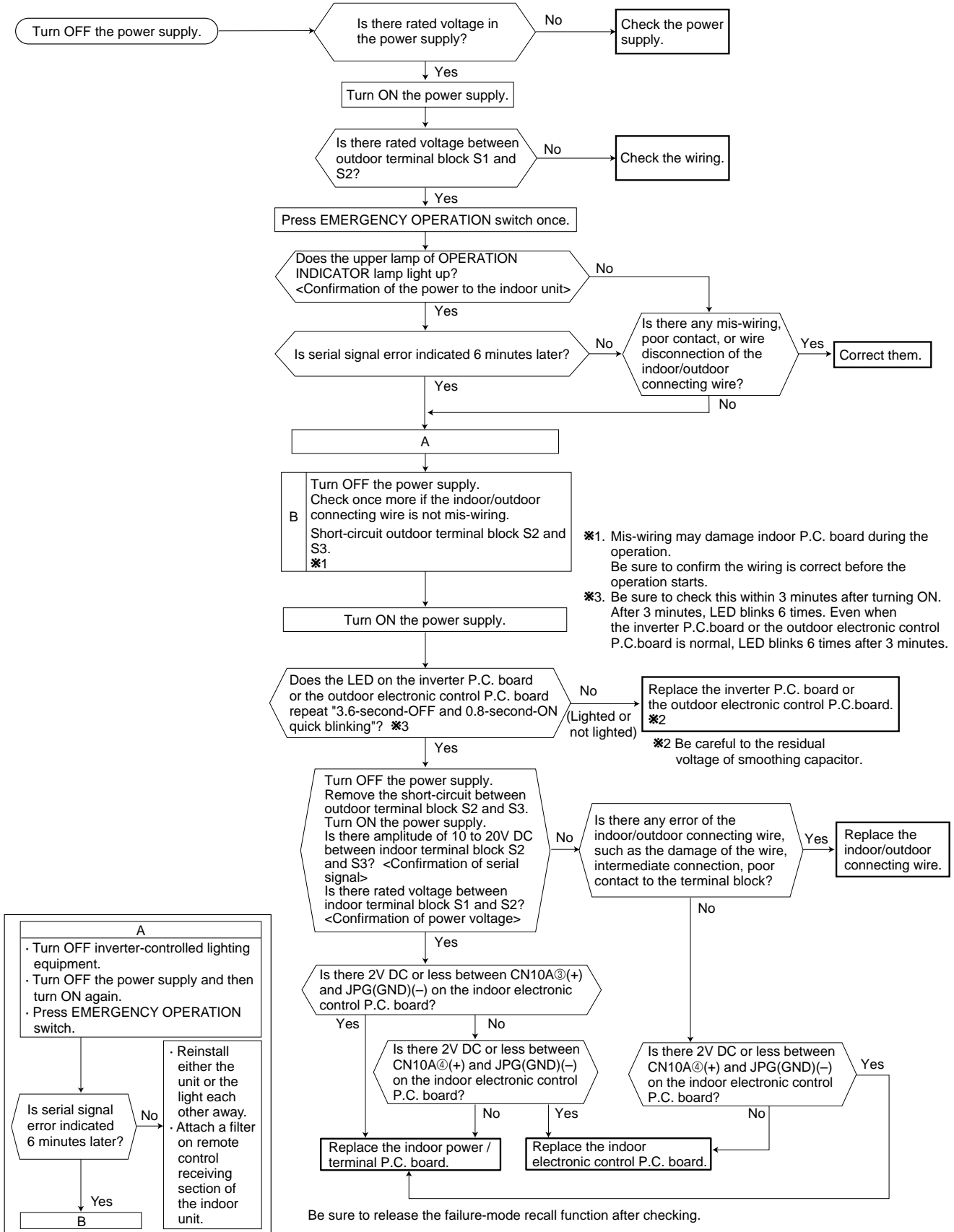

① Electromagnetic noise enters into TV sets or radios

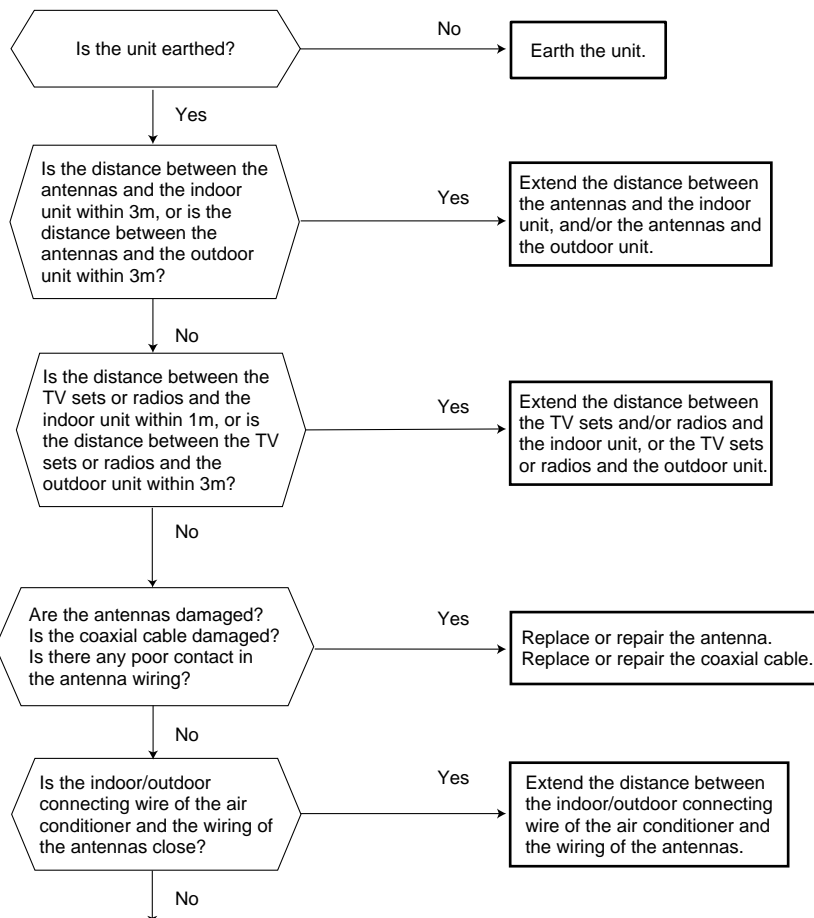

Outdoor base gets frozen.

Ⓟ Check of defrost heater

MUZ-GC25VAH MUZ-GC35VAH

Check the following points before checking electric continuity.

- 1) Does the resistance of ambient temperature thermistor have the characteristics? Refer to 11-6.1.
- 2) Is the resistance of defrost heater normal? Refer to 11-4.
- 3) Does the heater protector remain conducted (not open)?
- 4) Are both ambient temperature thermistor and circuit of defrost heater securely connected to connectors?

In HEAT mode, for more than 5 minutes, let the ambient temperature thermistor continue to read 5°C or below, and let the defrost thermistor continue to read -1°C or below.

NOTE: In case both thermistors are more than the above temperature, cool them with cold water etc...

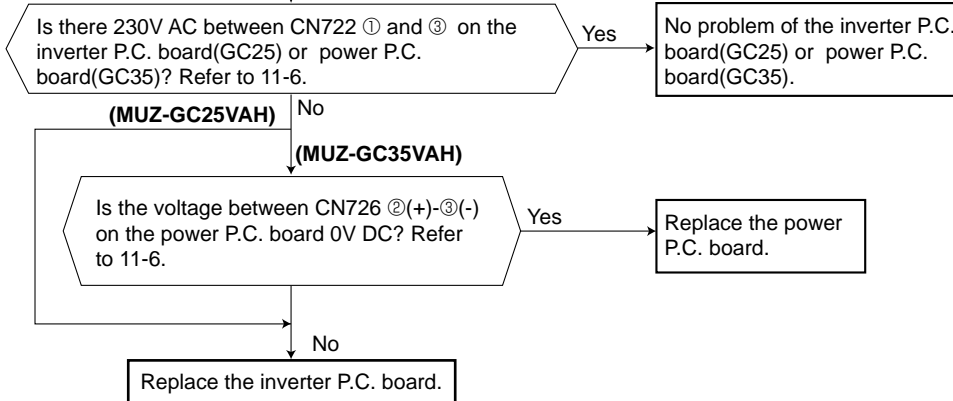

MUZ-GC25VAH Inverter P.C board

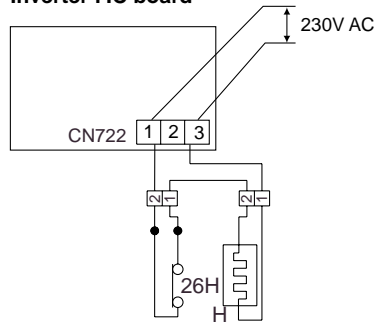

MUZ-GC35VAH Power P.C board

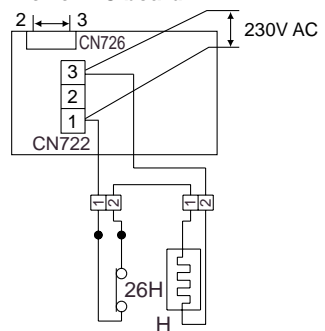

11-6. Test point diagram and voltage

1. Inverter P.C. board

MUZ-GC25VA MUZ-GC25VAH

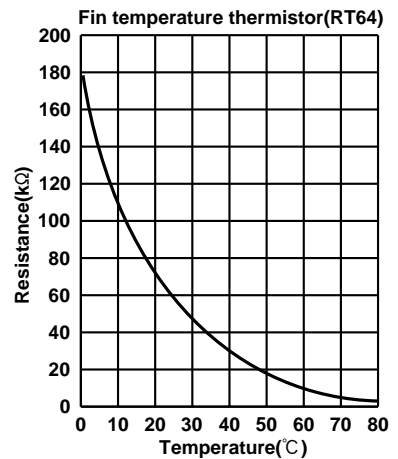
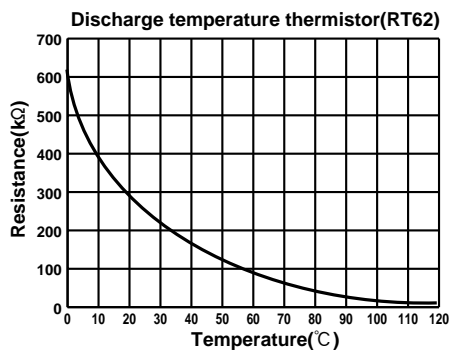
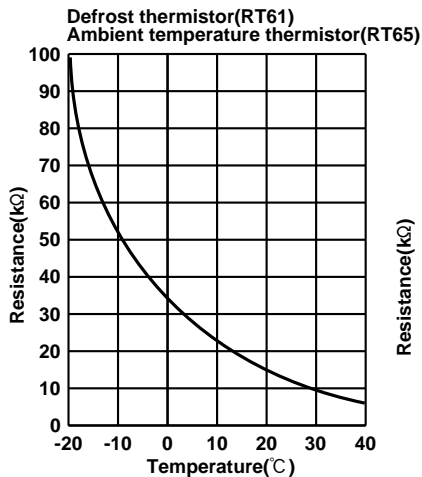
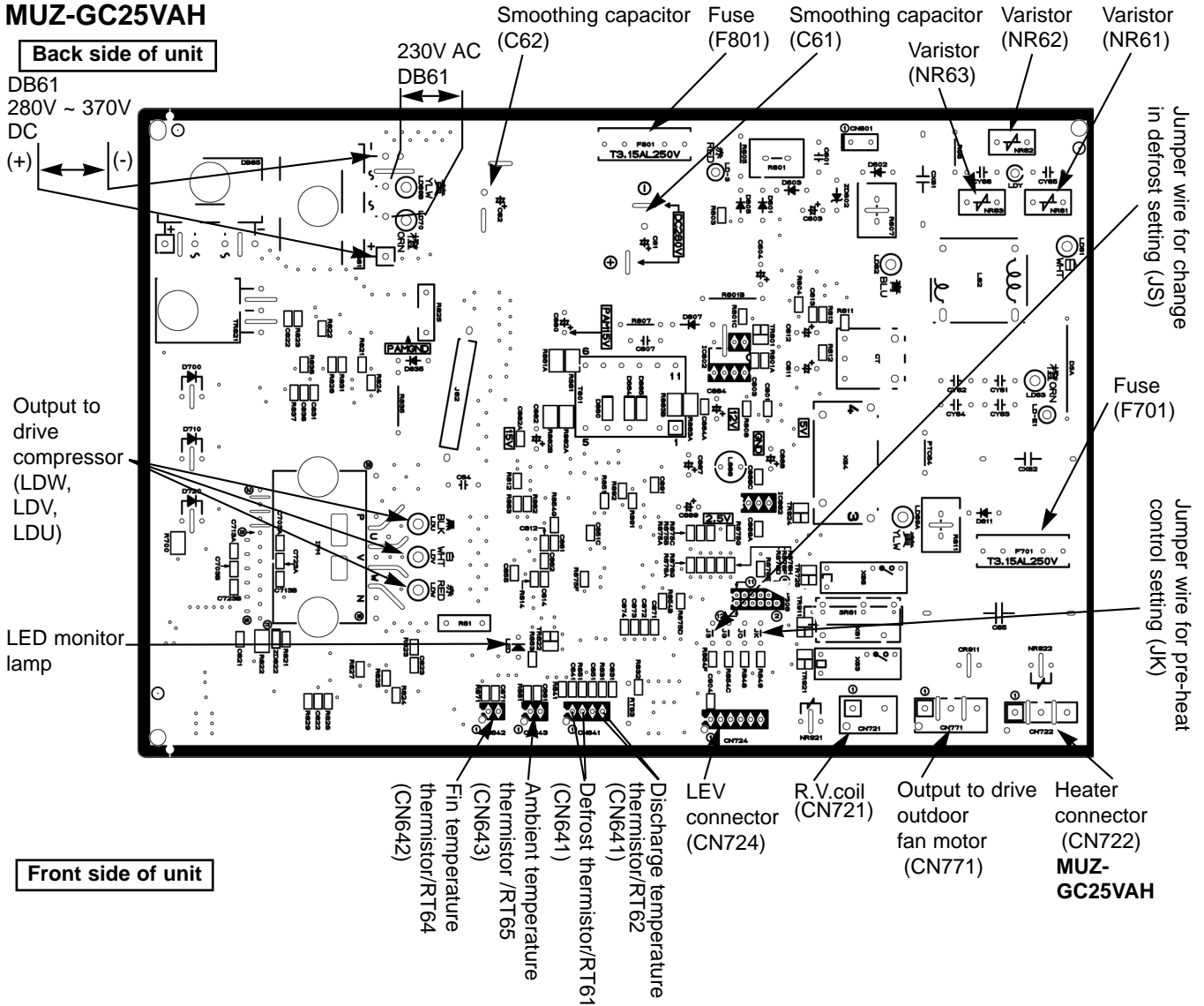

1. Inverter P.C. board
MUZ-GC35VA
MUZ-GC35VAH

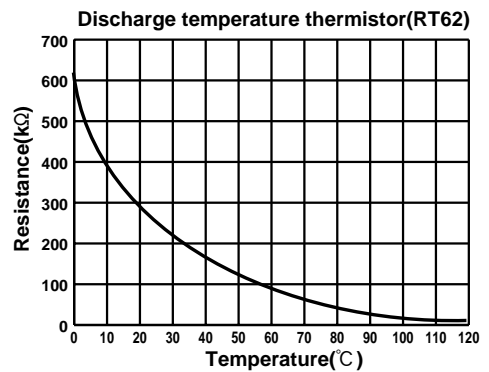
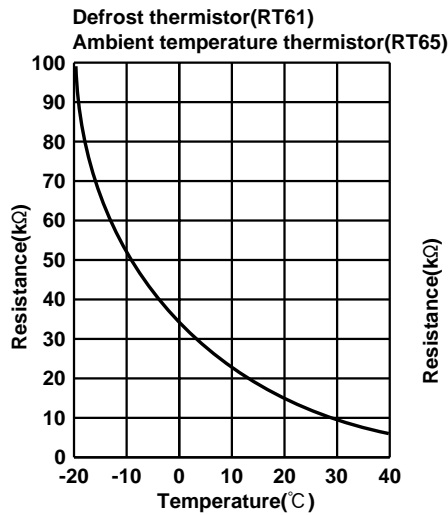
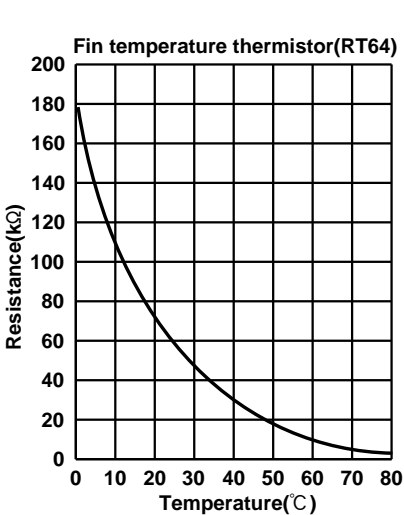
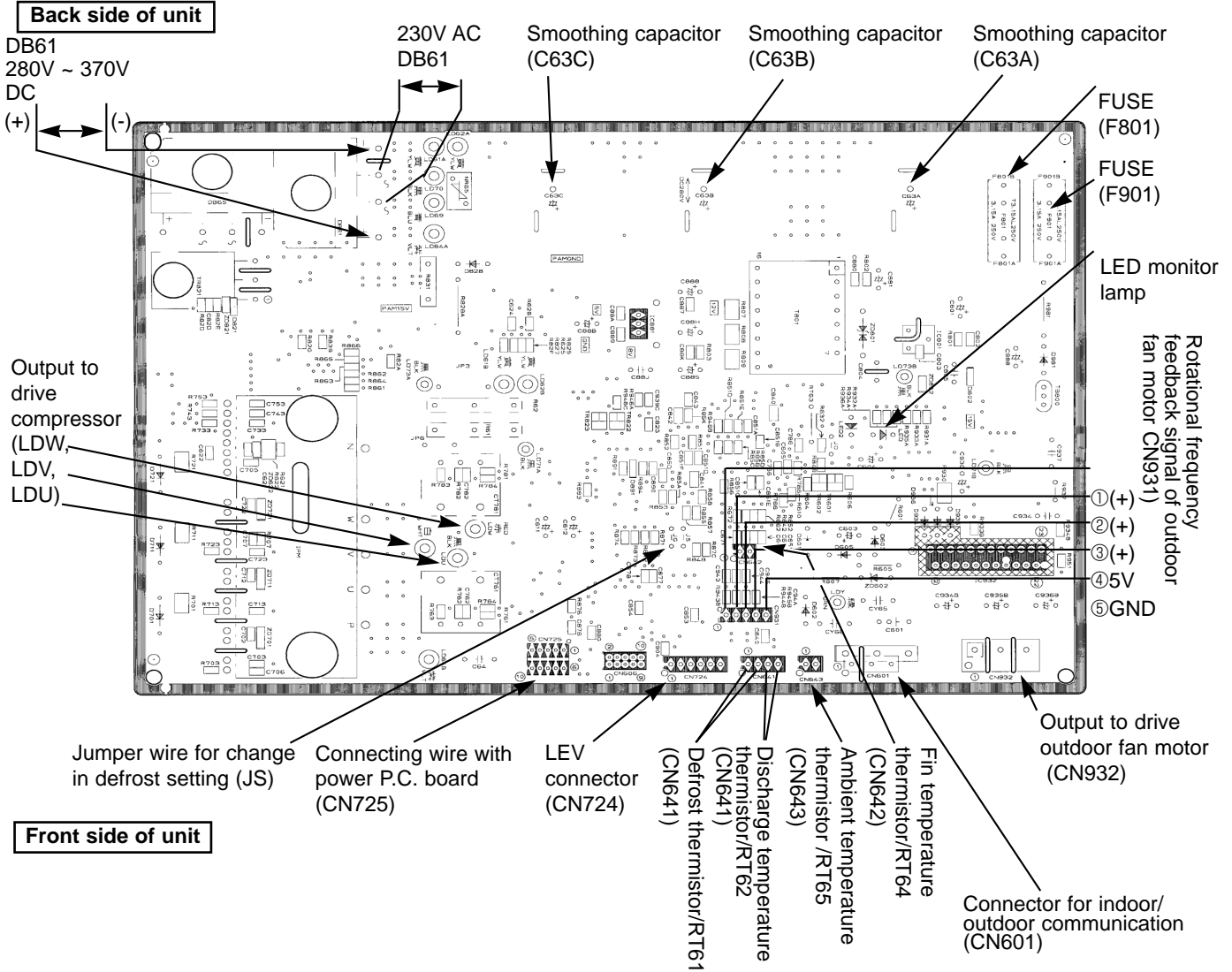

2. Power P.C. board
MUZ-GC35VA
MUZ-GC35VAH

Back side of unit

Front side of unit

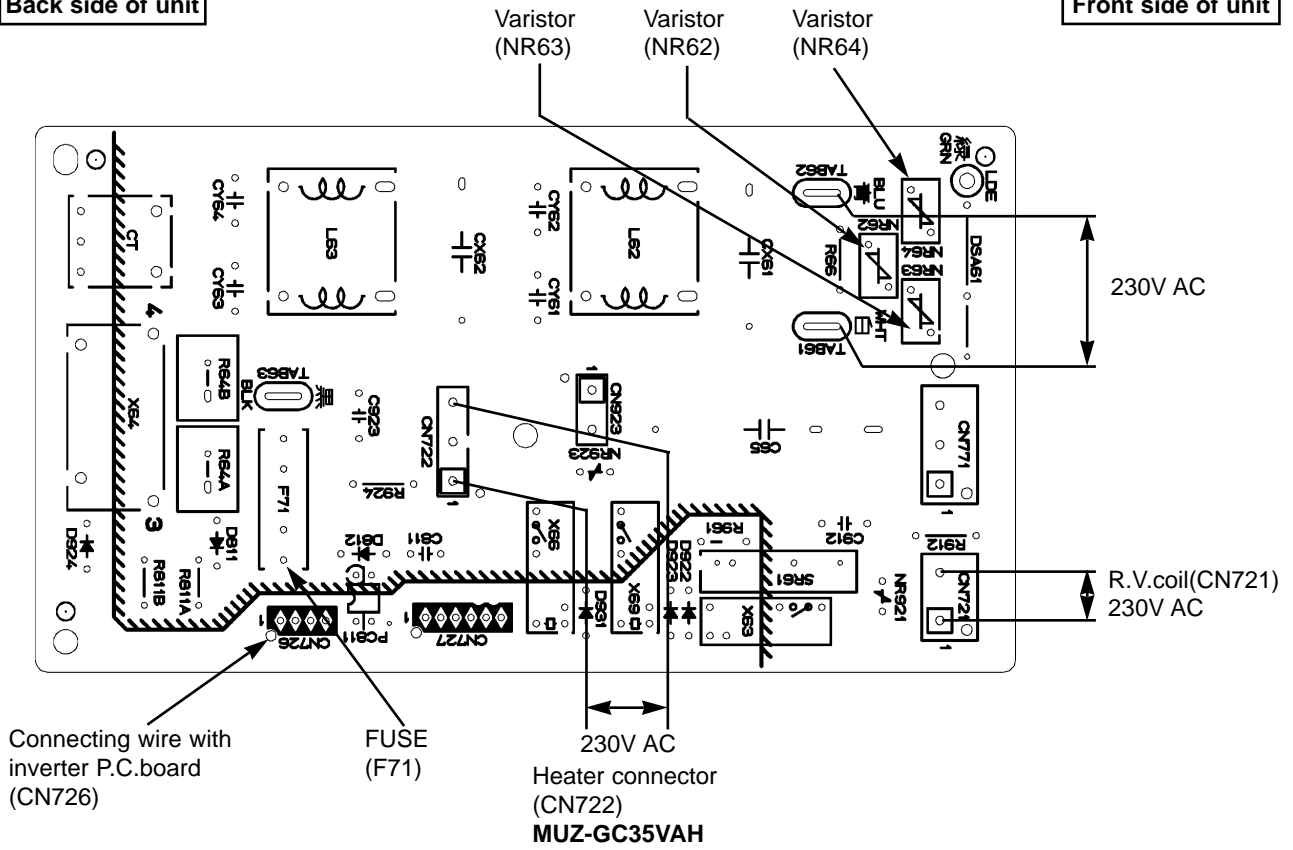

<"Terminal with locking mechanism" Detaching points>

The terminal which has the locking mechanism can be detached as shown below.
 There are two types (Refer to (1) and (2)) of the terminal with locking mechanism.
 The terminal without locking mechanism can be detached by pulling it out.
 Check the shape of the terminal before detaching.

(1) Slide the sleeve and check if there is a locking lever or not.

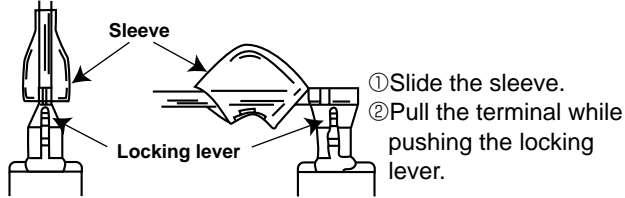

(2) The terminal with this connector has the locking mechanism.

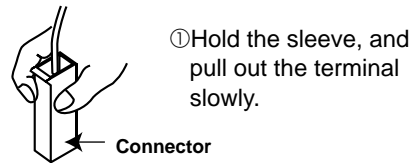

12-1. MUZ-GC25VA MUZ-GC25VAH

NOTE : Turn OFF power supply before disassembling.

OPERATING PROCEDURE	PHOTOS
<p>1. Removing cabinet and panels</p> <p>(1) Remove the screw fixing the service panel. (See Photo 2.) (2) Pull down the service panel and remove it. (See Photo 2.) (3) Disconnect the power supply and indoor/outdoor connecting wire. (4) Remove the screws fixing the top panel. (See Photo 1.) (5) Remove the top panel. (See Photo 1.) (6) Remove the screws fixing the cabinet. (See Photo 1.) (7) Remove the cabinet. (8) Remove the screws fixing the back panel. (9) Remove the back panel.</p> <p>Photo 2</p>	<p>Photo 1</p>

OPERATING PROCEDURE

2. Removing the inverter assembly, inverter P.C. board

- (1) Remove the cabinet and panels. (Refer to 1.)
- (2) Disconnect the earth wires (See Photo 3.), the lead wire to the reactor and the following connectors;
<Inverter P.C. board>
CN641 (Defrost thermistor and discharge temperature thermistor)
CN643 (Ambient temperature thermistor)
CN721 (4-way valve)
CN771 (Fan motor)
CN724 (LEV)
CN772 (Defrost heater **GC25VAH**)
- (3) Disconnect the compressor connector (CN61).
- (4) Remove the screws fixing the relay panel. (See Photo 3.)
- (5) Remove the inverter assembly. (See Photo 4.)
- (6) Remove the inverter P.C. board from the inverter assembly.

3. Removing R.V. coil

- (1) Remove the cabinet and panels. (Refer to 1.)
- (2) Remove the R.V. coil. (See Photo 5.)

4. Removing the discharge temperature thermistor and defrost thermistor

- (1) Remove the cabinet and panels. (Refer to 1.)
- (2) Pull out the discharge temperature thermistor from its holder. (See Photo 6.)
- (3) Pull out the defrost thermistor from its holder. (See Photo 5.)

PHOTOS

Photo 3

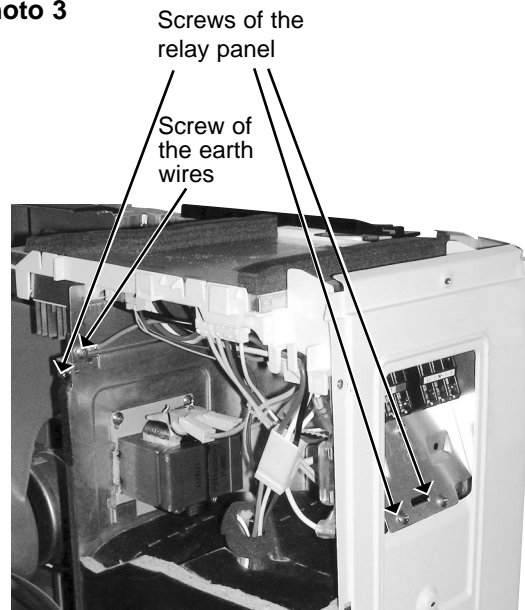

Photo 4 (Inverter assembly)

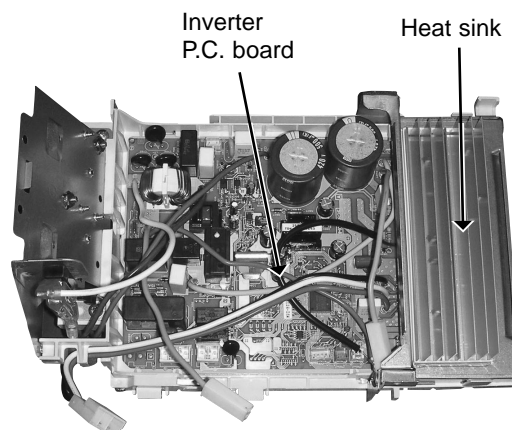
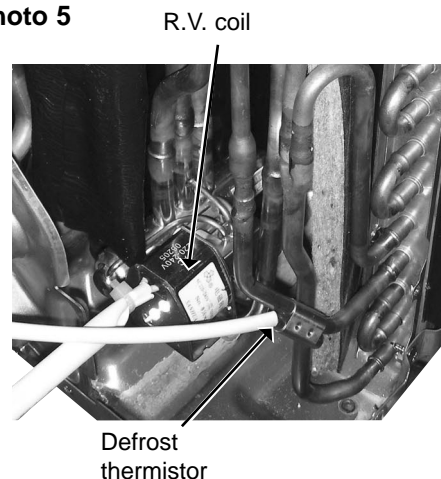

Photo 5



OPERATING PROCEDURE

5. Removing outdoor fan motor

- (1) Remove the cabinet and panels. (Refer to 1.)
- (2) Disconnect the connectors for outdoor fan motor.
- (3) Remove the propeller nut. (See Photo 7.)
- (4) Remove the propeller. (See Photo 7.)
- (5) Remove the screws fixing the fan motor. (See Photo 7.)
- (6) Remove the fan motor.

6. Removing the compressor and 4-way valve

- (1) Remove the cabinet and panels. (Refer to 1.)
- (2) Remove the inverter assembly. (Refer to 2.)
- (3) Recover gas from the refrigerant circuit.
NOTE: Recover gas from the pipes until the pressure gauge shows 0 kg/cm² (0 MPa).
- (4) Detach the welded part of the suction and the discharge pipe connected with compressor.
- (5) Remove the nuts of compressor legs.
- (6) Remove the compressor.
- (7) Detach the welded part of pipes connected with 4-way valve. (See Photo 8.)

PHOTOS

Photo 6



Discharge temperature thermistor

Photo 7

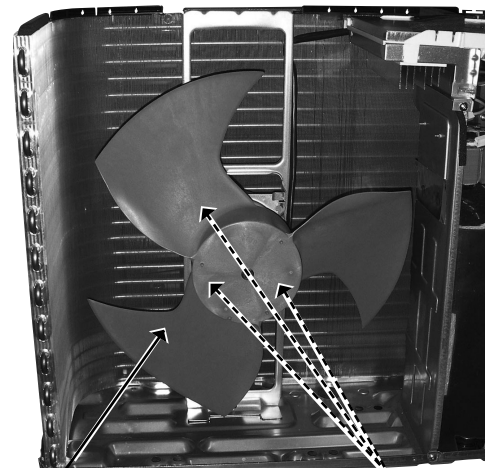

Propeller

Screws of the outdoor fan motor

Photo 8



Welded parts of 4-way valve

12-2. MUZ-GC35VA MUZ-GC35VAH

NOTE : Turn OFF power supply before disassembling.

OPERATING PROCEDURE

1. Removing the cabinet

- (1) Remove the screw fixing the service panel. (See Photo 2.)
- (2) Pull down the service panel and remove it. (See Photo 2.)
- (3) Disconnect the power supply and indoor/outdoor connecting wire.
- (4) Remove the screws fixing the top panel. (See Photo 1.)
- (5) Remove the top panel. (See Photo 1.)
- (6) Remove the screws fixing the cabinet.
- (7) Remove the cabinet.
- (8) Remove the screws fixing the back panel.
- (9) Remove the back panel.

PHOTOS

Photo 1

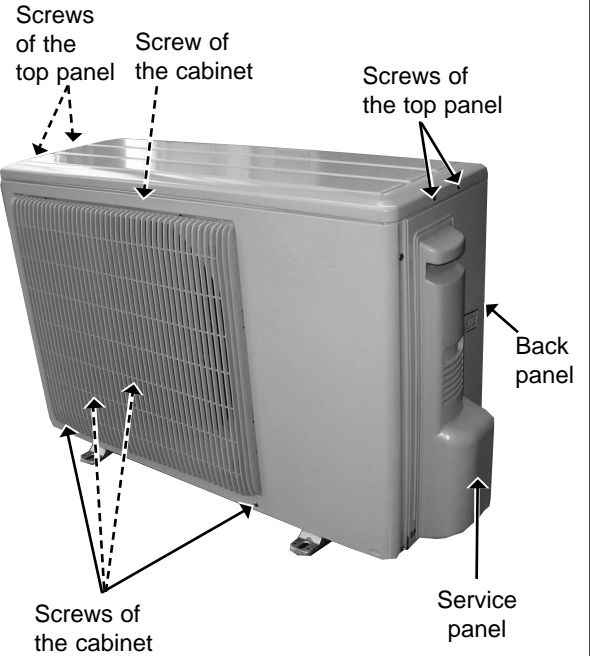
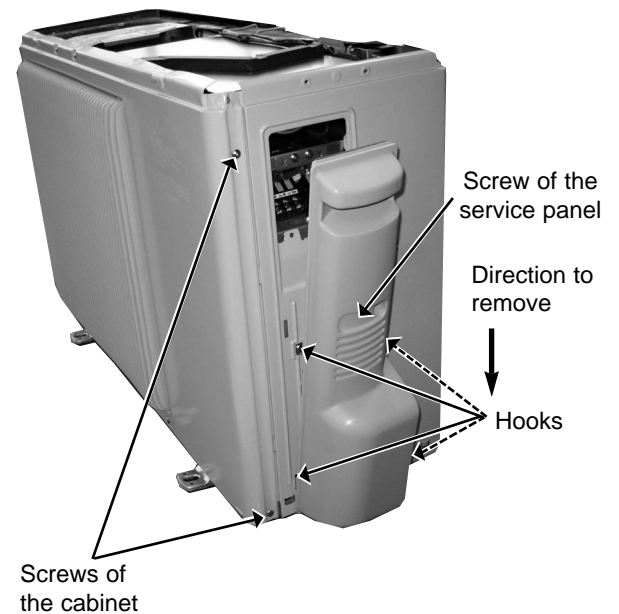

Photo 2



OPERATING PROCEDURE

2. Removing the inverter assembly, inverter P.C. board and power P.C. board

- (1) Remove the cabinet and panels. (Refer to 1.)
- (2) Disconnect the earth wires (See Photo 3.), the lead wire to the reactor and the following connectors;
<Power P.C. board>
CN721 (4-way valve)
CN722 (Defrost heater) MUZ-GC35VAH
<Inverter P.C. board>
CN931, CN932 (Fan motor)
CN641 (Defrost thermistor and discharge temperature thermistor)
CN643 (Ambient temperature thermistor)
CN724 (LEV)
- (3) Remove the compressor connector (CN61).
- (4) Remove the screws fixing the relay panel. (See Photo 3.)
- (5) Remove the inverter assembly. (See Photo 4.)
- (6) Remove the inverter P.C. board from the inverter assembly.
- (7) Remove the screw fixing the power P.C. board. (See Photo 4.)
- (8) Remove the power P.C. board from the inverter assembly.

3. Removing R.V. coil

- (1) Remove the cabinet and panels. (Refer to 1.)
- (2) Remove the R.V. coil. (See Photo 5.)

4. Removing the discharge temperature thermistor and defrost thermistor

- (1) Remove the cabinet and panels. (Refer to 1.)
- (2) Pull out the discharge temperature thermistor from its holder. (See Photo 5.)
- (3) Pull out the defrost thermistor from its holder. (See Photo 6.)

PHOTOS

Photo 3

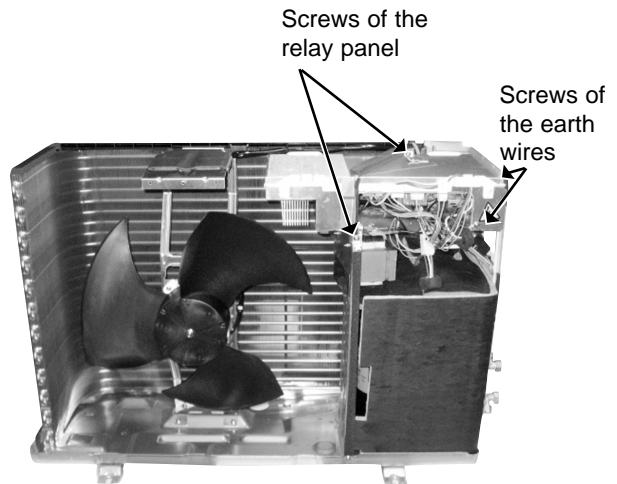

Photo 4 (inverter assembly)

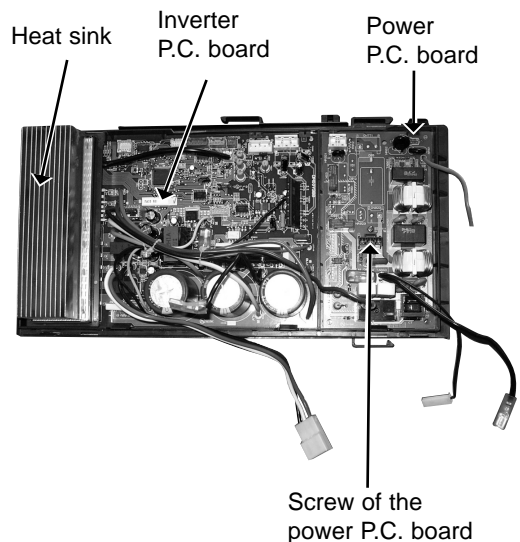
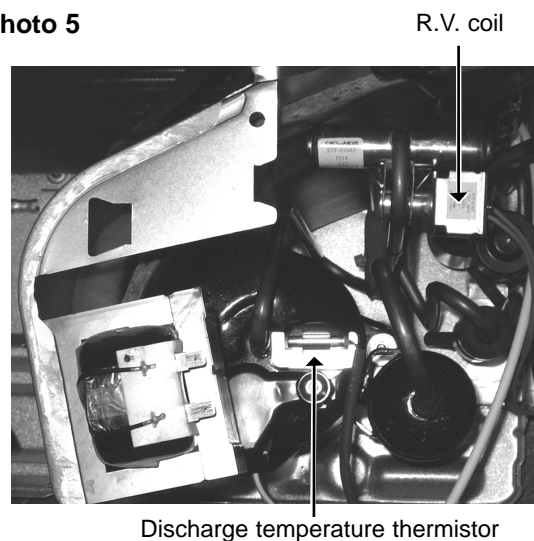

Photo 5



OPERATING PROCEDURE

5. Removing outdoor fan motor

- (1) Remove the cabinet and panels. (Refer to 1.)
- (2) Disconnect the connectors for outdoor fan motor.
- (3) Remove the propeller nut. (See Photo 7.)
- (4) Remove the propeller. (See Photo 7.)
- (5) Remove the screws fixing the fan motor. (See Photo 7.)
- (6) Remove the fan motor.

6. Removing the compressor and 4-way valve

- (1) Remove the cabinet and panels. (Refer to 1.)
- (2) Remove the inverter assembly. (Refer to 2.)
- (3) Recover gas from the refrigerant circuit.
NOTE: Recover gas from the pipes until the pressure gauge shows 0kg/cm² (0 MPa).
- (4) Detach the welded part of the suction and the discharge pipe connected with compressor.
- (5) Remove the nuts of compressor legs.
- (6) Remove the compressor.
- (7) Detach the welded part of pipes connected with 4-way valve. (See Photo 8.)

PHOTOS

Photo 6

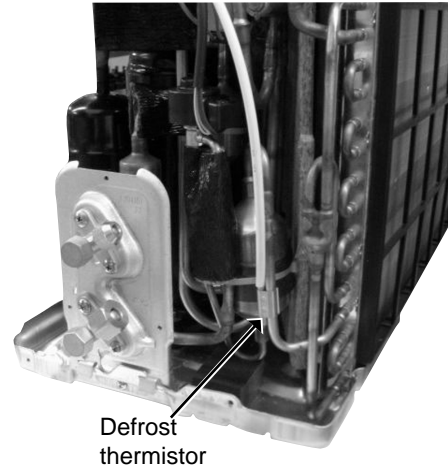
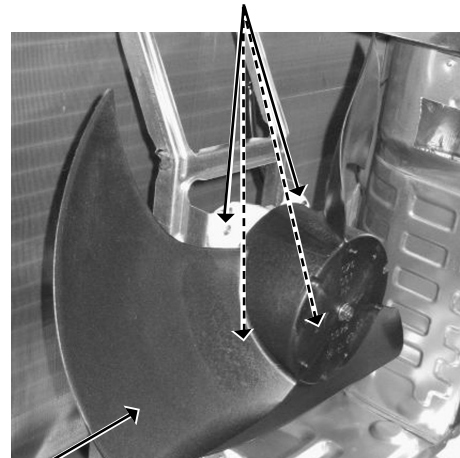

Photo 7

Screws of the outdoor fan motor



Propeller

Photo 8

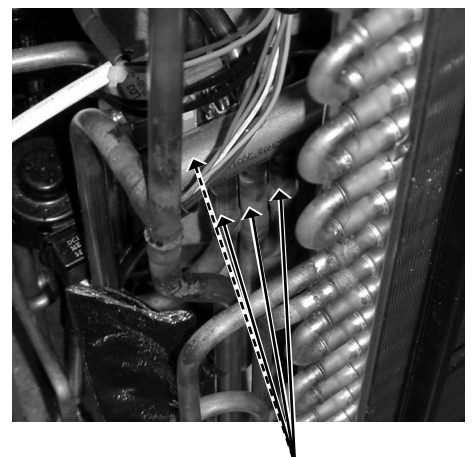

Welded parts of 4-way valve



© Copyright 2007 MITSUBISHI ELECTRIC ENGINEERING CO.,LTD
Distributed in Jan. 2007. No. OBH469 6
Made in Japan

New publication, effective Jan. 2007
Specifications subject to change without notice.