

**Revision B:**

• MUZ-HC35VA-**E2** and MUZ-HC35VAB-**E2** have been added.

Please void OBH467 REVISED EDITION-A.

# OUTDOOR UNIT SERVICE MANUAL



**No. OBH467  
REVISED EDITION-B**

## Models

<b>MUZ-HC25VA</b>	-	<b>E1</b>
<b>MUZ-HC35VA</b>	-	<b>E1</b>
<b>MUZ-HC35VA</b>	-	<b>E2</b>
<b>MUZ-HC35VAB</b>	-	<b>E1</b>
<b>MUZ-HC35VAB</b>	-	<b>E2</b>

Indoor unit service manual  
MSZ-HC•VA Series (OBH466)  
MSZ-CHC•VA Series (OBH522)

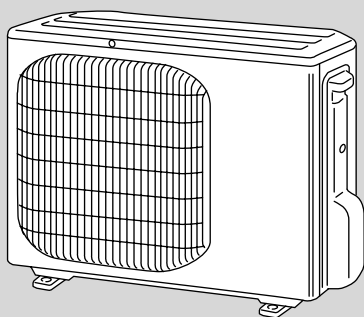

## CONTENTS

1. TECHNICAL CHANGES .....	3
2. PART NAMES AND FUNCTIONS .....	4
3. SPECIFICATION .....	5
4. NOISE CRITERIA CURVES .....	7
5. OUTLINES AND DIMENSIONS .....	8
6. WIRING DIAGRAM .....	9
7. REFRIGERANT SYSTEM DIAGRAM .....	11
8. PERFORMANCE CURVES .....	13
9. ACTUATOR CONTROL .....	24
10. SERVICE FUNCTIONS .....	25
11. TROUBLESHOOTING .....	25
12. DISASSEMBLY INSTRUCTIONS .....	40

**PARTS CATALOG (OBB467)**

**NOTE:**

RoHS compliant products have <G> mark on the spec name plate.



**Revision A:**

•Table “ADDITIONAL REFRIGERANT CHARGE” of “7. REFRIGERANT SYSTEM DIAGRAM” has been corrected.

**Revision B:**

• MUZ-HC35VA-[E2](#) and MUZ-HC35VAB-[E2](#) have been added.

# 1

## TECHNICAL CHANGES

**MUZ-HA25VA -<sup>E1</sup>** → **MUZ-HC25VA -<sup>E1</sup>**

**MUZ-HA35VA -<sup>E1</sup>** → **MUZ-HC35VA -<sup>E1</sup>**

**MUZ-HA35VA -<sup>E1</sup>** → **MUZ-HC35VAB -<sup>E1</sup>**

1. Outdoor model has been changed.

**MUZ-HC35VA -<sup>E1</sup>** → **MUZ-HC35VA -<sup>E2</sup>**

**MUZ-HC35VAB -<sup>E1</sup>** → **MUZ-HC35VAB -<sup>E2</sup>**

1. REFRIGERANT SYSTEM has been changed.

## 2

# PART NAMES AND FUNCTIONS

MUZ-HC25VA MUZ-HC35VA MUZ-HC35VAB

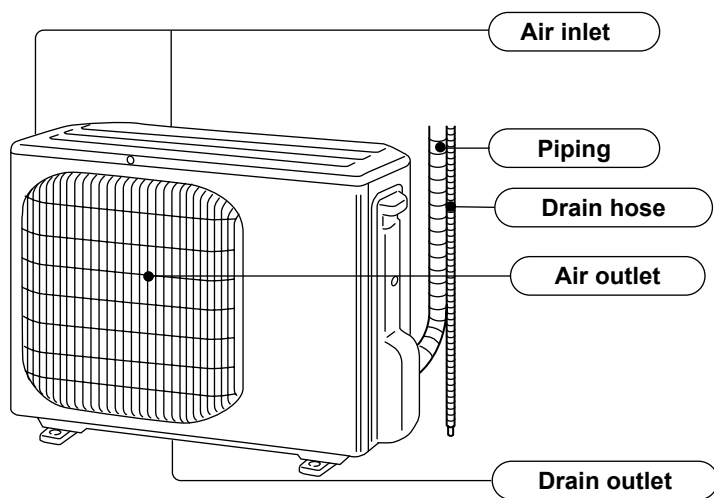

## ACCESSORIES

①	Drain socket	1
---	--------------	---

## 3

## SPECIFICATION

Outdoor model		MUZ-HC25VA		MUZ-HC35VA		MUZ-HC35VAB		
Function		Cooling	Heating	Cooling	Heating	Cooling	Heating	
Power supply		Single phase 230 V, 50 Hz						
Capacity Rated frequency (Min.-Max.)		kW	2.5 (0.9-3.0)	3.2 (0.9-4.4)	3.15 (1.0-3.7)	3.6 (0.9-4.8)	3.4 (1.0-3.7)	3.6 (0.9-4.8)
Electrical data	Breaker capacity	A	10					
	Running current *1 (Total)	A	3.7	4.2	4.8	4.8	5.3	4.8
	Power input *1 (Total)	W	770	880	980	995	1130	995
	Power factor *1 (Total)	%	90	91	89	90	93	90
	Starting current *1 (Total)	A	4.2		4.8		5.3	
Coefficient of performance (C.O.P) *1 (Total)			3.25	3.64	3.21	3.62	3.01	3.62
Compressor	Model		KNB065FDTH(C)		E1	KNB073FEDH KNB073FGDH		
	Output	W	500		E2	KNB073FGDHC		
	Current *1	A	3.24	3.74	4.34	4.34	4.84	4.34
Fan motor	Model		RA6V21-AB or BB or BD					
	Current *1	A	0.24					
Dimensions W × H × D		mm	684 × 540 × 255					
Weight		kg	25					
Special remarks	Dehumidification	ℓ/h	1.4	-	2.0	-	2.0	-
	Air flow *1	m <sup>3</sup> /h	1,812	1,788	1,800	1,776	1,800	1,776
	Sound level *1	dB(A)	46	47	47	48	47	48
	Fan speed	rpm	810	800	800	790	800	790
	Fan speed regulator		1					
	Refrigerant filling capacity (R410A)	kg	0.73		0.75			
Refrigeration oil (Model)			NEO22					

**NOTE:** Test conditions are based on ISO 5151.

Cooling: Indoor Dry-bulb temperature 27°C  
 Outdoor Dry-bulb temperature 35°C  
 Heating: Indoor Dry-bulb temperature 20°C  
 Outdoor Dry-bulb temperature 7°C

Wet-bulb temperature 19°C

Wet-bulb temperature 6°C

Refrigerant piping length (one way): 5 m

\*1 Measured under rated operating frequency.

### Specifications and rating conditions of main electric parts

Item	Model	MUZ-HC25	MUZ-HC35VA- <sup>E1</sup>	MUZ-HC35VAB- <sup>E2</sup>
		MUZ-HC35VA- <sup>E1</sup>	MUZ-HC35VAB- <sup>E1</sup>	MUZ-HC35VAB- <sup>E2</sup>
Current transformer	(CT)	20 A		
Smoothing capacitor	(C61, C62)	500 μF 420 V		
Diode module	(DB61)	15 A 600 V		
	(DB65)	10 A 600 V		
Fuse	(F61)	T20AL250V		
	(F701, F801)	T3.15AL250V		
Intelligent power module	(IPM)	10 A 600 V		
Expansion valve coil	(LEV)	—	DC 12 V	
Reactor	(L61)	18 mH 7 A		
Current-detecting resistor	(R61)	45 mΩ 5 W		
	(R825)	25 mΩ 5 W		
Current-limiting PTC thermistor	(PTC64)	33 Ω		
Terminal block	(TB1, TB2)	3 P		
Relay	(X61)	5 A 250 V		
	(X63)	3 A 250 V		
	(X64)	20 A 250 V		
R.V. coil	(21S4)	SHF-4-10W5		
Outdoor fan motor thermal fuse		Open 152°C (RA6V21-AB) or Open 126°C (RA6V21-BB or BD)		
IGBT	(TR821)	30 A 600 V		

# 4

# NOISE CRITERIA CURVES

## MUZ-HC25VA

FUNCTION	SPL(dB(A))	LINE
COOLING	46	●—●
HEATING	47	○—○

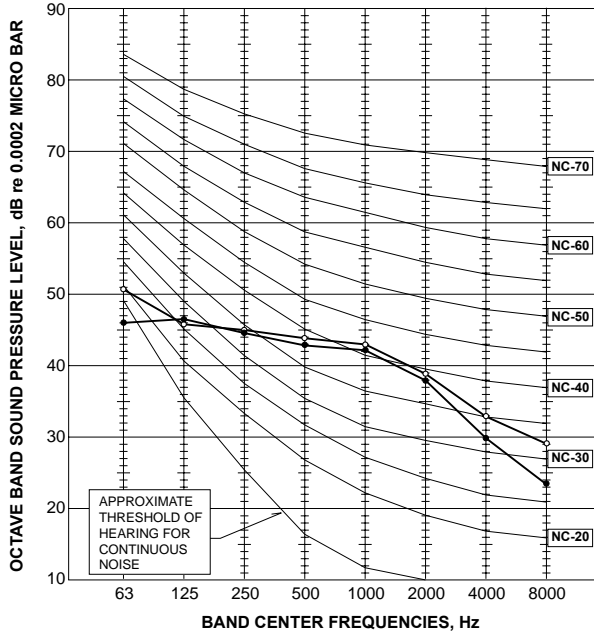

## MUZ-HC35VA

FUNCTION	SPL(dB(A))	LINE
COOLING	47	●—●
HEATING	48	○—○

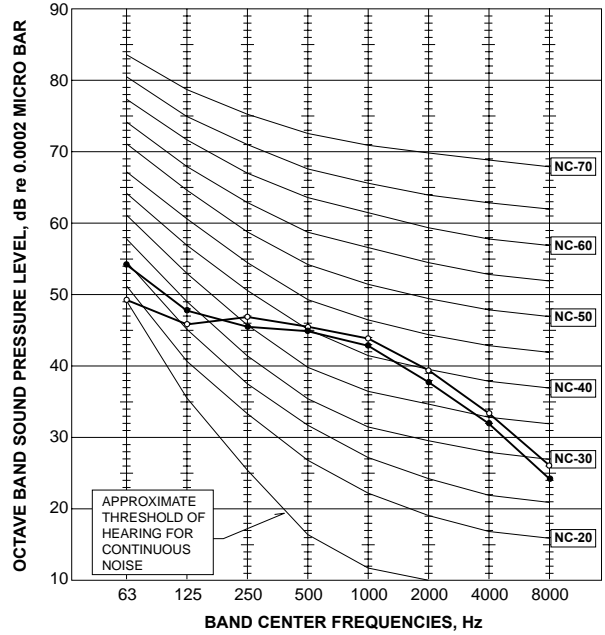

## MUZ-HC35VAB

FUNCTION	SPL(dB(A))	LINE
COOLING	47	●—●
HEATING	48	○—○

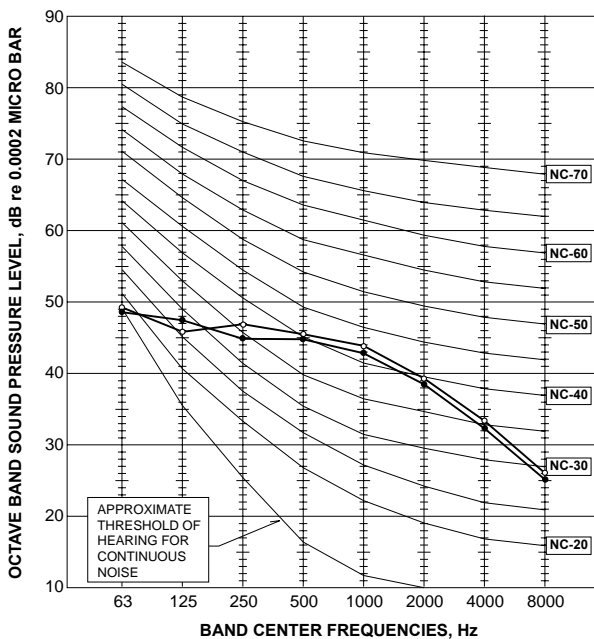

### Test conditions

Cooling : Dry-bulb temperature 35°C

Heating : Dry-bulb temperature 7°C Wet-bulb temperature 6°C

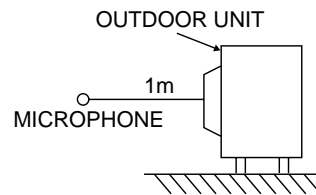

# 5

# OUTLINES AND DIMENSIONS

MUZ-HC25VA MUZ-HC35VA MUZ-HC35VAB

Unit : mm

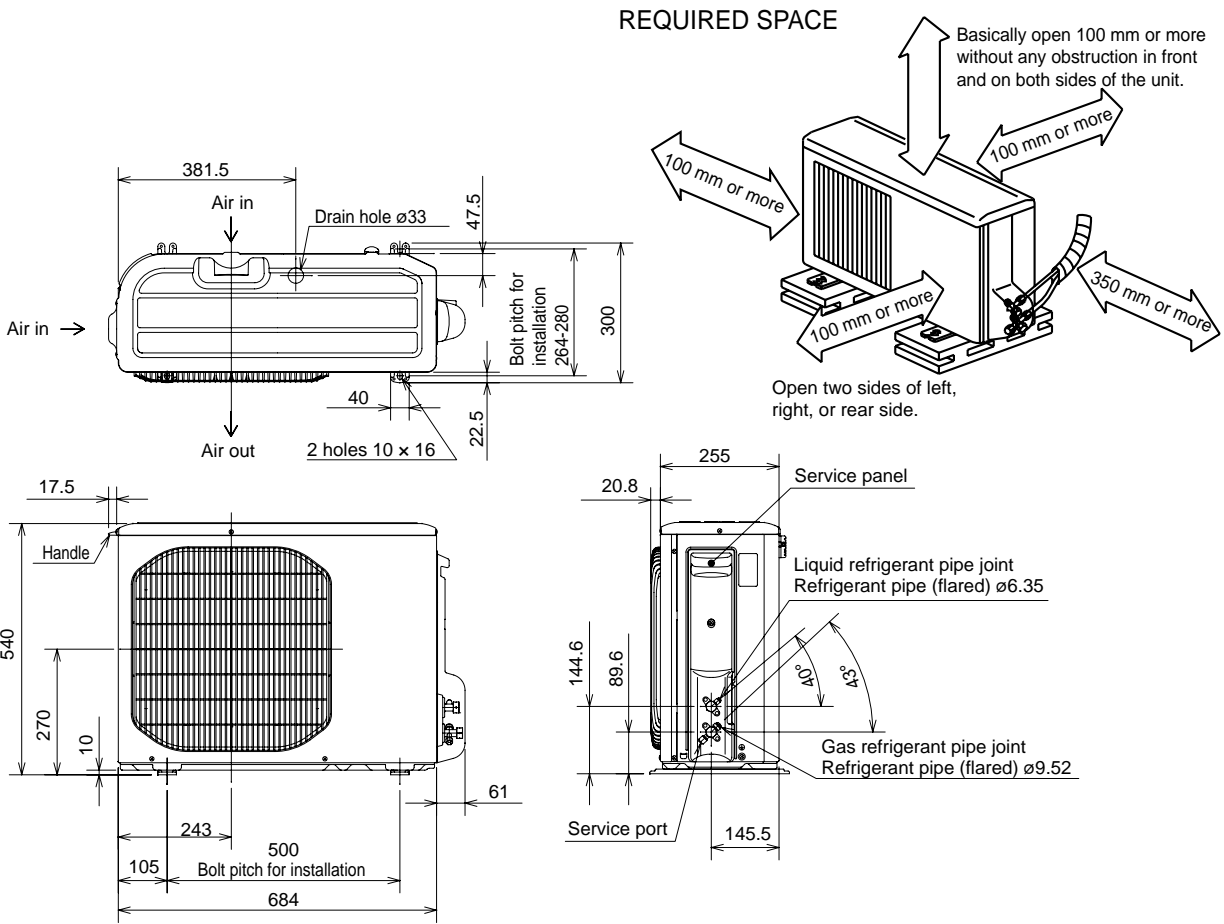



MUZ-HC25VA MUZ-HC35VA-E1 MUZ-HC35VAB-E1

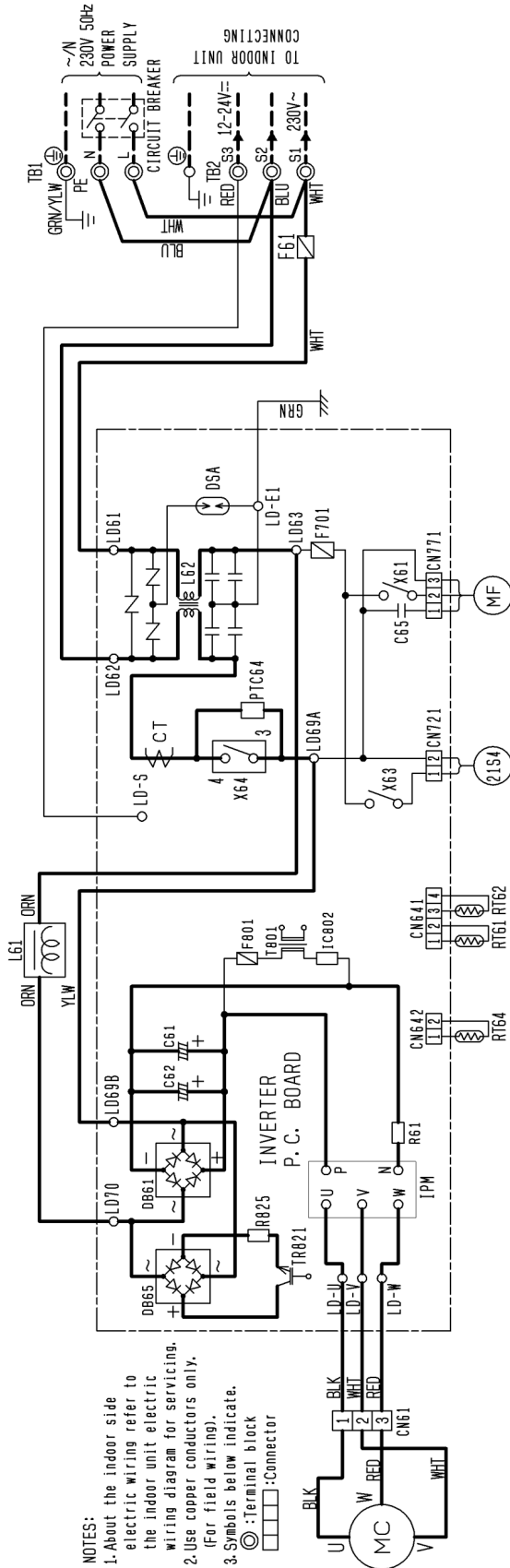

NOTES:  
 1. About the indoor side electric wiring refer to the indoor unit electric wiring diagram for servicing.  
 2. Use copper conductors only. (For field wiring).  
 3. Symbols below indicate.  
 ○: Terminal block  
 □: Connector

SYMBOL	NAME	SYMBOL	NAME	SYMBOL	NAME
CT	CURRENT TRANSFORMER	L61	REACTOR	TB1, TB2	TERMINAL BLOCK
C61, C62	SMOOTHING CAPACITOR	L62	CMC COIL	TR821	SWITCHING POWER TRANSISTOR
C65	FAN MOTOR CAPACITOR	MC	COMPRESSOR	T601	TRANSFORMER
DB6L, DB65	DIODE MODULE	MF	FAN MOTOR (INNER FUSE)	X61, X63, X64	RELAY
DSA	SURGE ABSORBER	PTC64	CIRCUIT PROTECTION	21S4	REVERSING VALVE COIL
F61	FUSE (T20AL250V)	RT61	DEFROST THERMISTOR		
F70L, F801	FUSE (T3.15AL250V)	RT62	DISCHARGE TEMP. THERMISTOR		
IC802	INTELLIGENT POWER DEVICE	RT64	FIN TEMP. THERMISTOR		
IPM	INTELLIGENT POWER MODULE	R61, R825	CURRENT-DETECTING RESISTOR		

**MUZ-HC35VA-E2 MUZ-HC35VAB-E2**

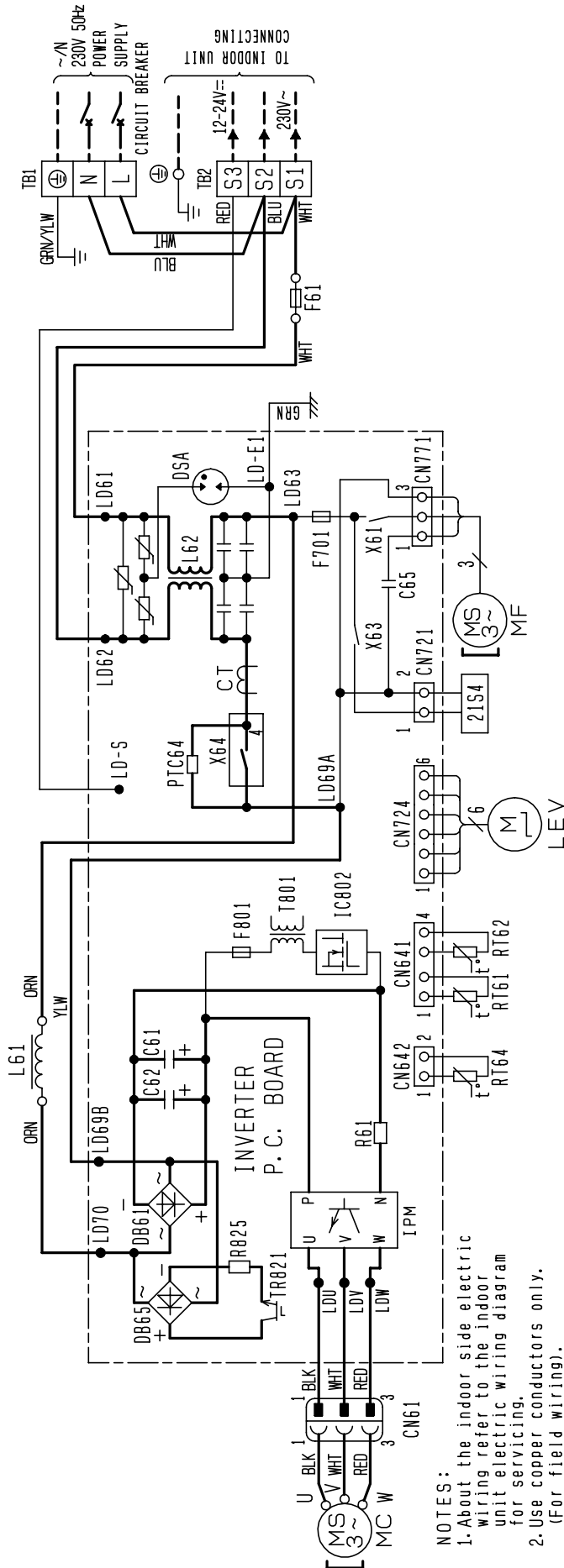

- NOTES:**
1. About the indoor side electric wiring refer to the indoor unit electric wiring diagram for servicing.
  2. Use copper conductors only. (For field wiring).

SYMBOL	NAME	SYMBOL	NAME	SYMBOL	NAME
CT	CURRENT TRANSFORMER	IPM	INTELLIGENT POWER MODULE	RT62	DISCHARGE TEMP. THERMISTOR
C61, C62	SMOOTHING CAPACITOR	LEV	EXPANSION VALVE COIL	RT64	FIN TEMP. THERMISTOR
C65	FAN MOTOR CAPACITOR	L61	REACTOR	R61, R825	CURRENT-DETECTING RESISTOR
DB61, DB65	DIODE MODULE	L62	CMC COIL	TB1, TB2	TERMINAL BLOCK
DSA	SURGE ABSORBER	MC	COMPRESSOR	TR821	SWITCHING POWER TRANSISTOR
F61	FUSE (T20AL250V)	MF	FAN MOTOR (INNER FUSE)	T801	TRANSFORMER
F701, F801	FUSE (T3, 15AL250V)	PTC64	CIRCUIT PROTECTION	X61, X63, X64	RELAY
IC802	INTELLIGENT POWER DEVICE	RT61	DEFROST THERMISTOR	21S4	REVERSING VALVE COIL

# 7

# REFRIGERANT SYSTEM DIAGRAM

MUZ-HC25VA MUZ-HC35VA-**E1** MUZ-HC35VAB-**E1**

Unit : mm

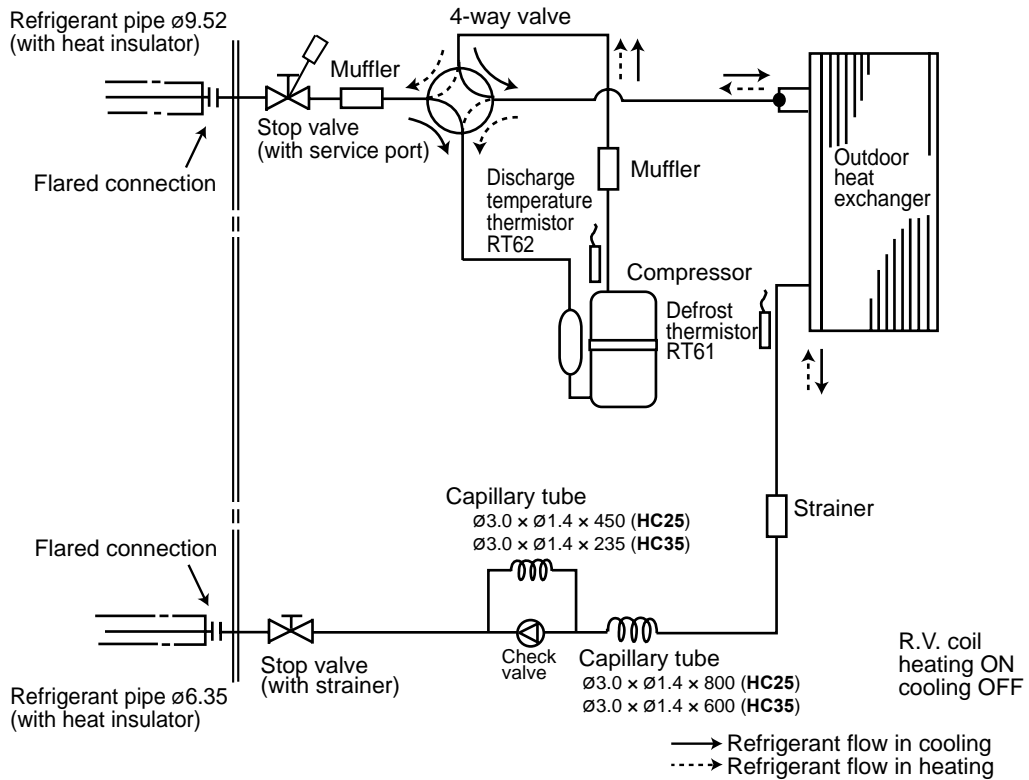

MUZ-HC35VA-**E2** MUZ-HC35VAB-**E2**

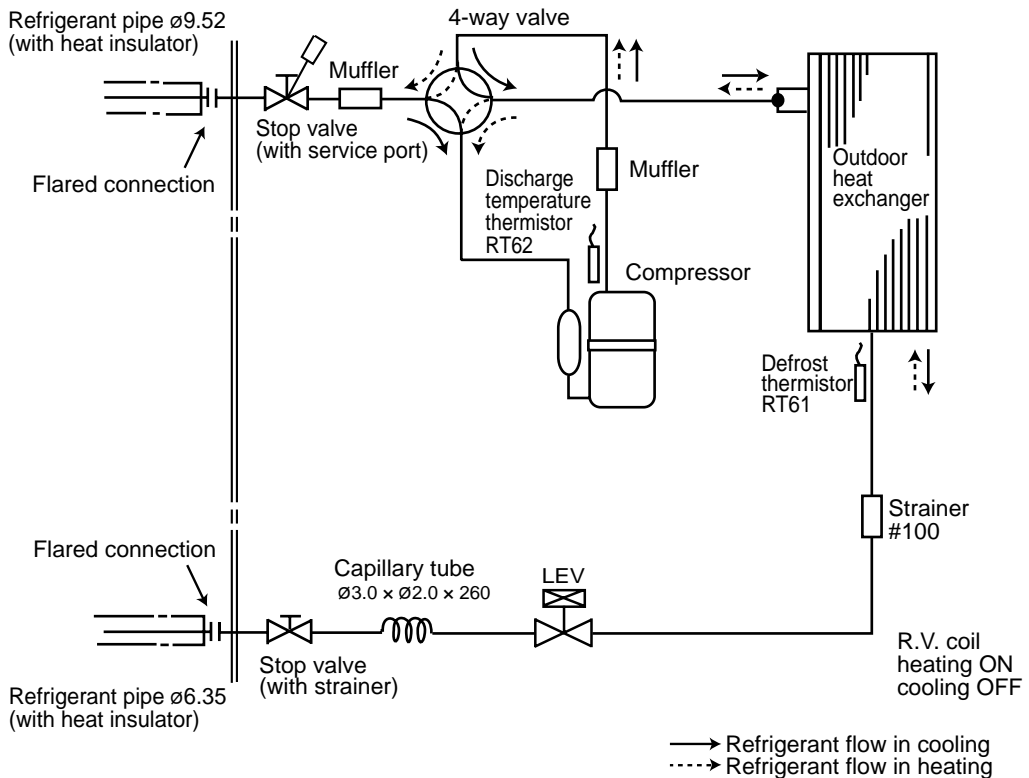



**MAX. REFRIGERANT PIPING LENGTH and MAX. HEIGHT DIFFERENCE**

	Refrigerant piping: m		Piping size O.D: mm	
	Max. Length A	Max. Height difference B	Gas	Liquid
<b>MUZ-HC25VA</b> <b>MUZ-HC35VA</b> <b>MUZ-HC35VAB</b>	10	5	9.52	6.35

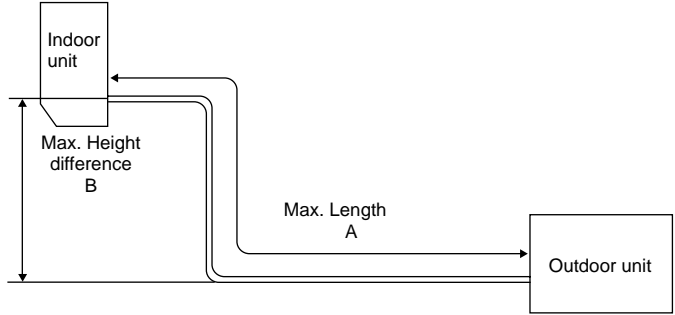

**ADDITIONAL REFRIGERANT CHARGE (R410A : g)**

Model	Outdoor unit precharged	Refrigerant piping length (one way)					
		5 m	6 m	7 m	8 m	9 m	10 m
<b>MUZ-HC25VA</b> <b>MUZ-HC35VA</b> <b>MUZ-HC35VAB</b>	1,150	0	0	0	90	120	150

Calculation: X g = 30 g/m × (Refrigerant piping length (m) - 5)

**NOTE :** Refrigerant piping exceeding 7 m requires additional refrigerant charge according to the calculation.

**MUZ-HC25VA MUZ-HC35VA MUZ-HC35VAB**

The standard specifications apply only to the operation of the air conditioner under normal conditions. Since operating conditions vary according to the areas where these units are installed, the following information has been provided to clarify the operating characteristics of the air conditioner under the conditions indicated by the performance curve.

**(1) GUARANTEED VOLTAGE**

198 ~ 264 V, 50 Hz

**(2) AIR FLOW**

Air flow should be set at MAX.

**(3) MAIN READINGS**

(1) Indoor intake air wet-bulb temperature :	°C WB	} Cooling
(2) Indoor outlet air wet-bulb temperature :	°C WB	
(3) Outdoor intake air dry-bulb temperature :	°C DB	
(4) Total input:	W	} Heating
(5) Indoor intake air dry-bulb temperature :	°C DB	
(6) Outdoor intake air wet-bulb temperature :	°C WB	
(7) Total input :	W	

Indoor air wet/dry-bulb temperature difference on the left side of the following chart shows the difference between the indoor intake air wet/dry-bulb temperature and the indoor outlet air wet/dry-bulb temperature for your reference at service.

**How to measure the indoor air wet-bulb/dry-bulb temperature difference**

1. Attach at least 2 sets of wet and dry-bulb thermometers to the indoor air intake as shown in the figure, and at least 2 sets of wet and dry-bulb thermometers to the indoor air outlet. The thermometers must be attached to the position where air speed is high.
2. Attach at least 2 sets of wet and dry-bulb thermometers to the outdoor air intake. Cover the thermometers to prevent direct rays of the sun.
3. Check that the air filter is cleaned.
4. Open windows and doors of room.
5. Press the EMERGENCY OPERATION switch once (twice) to start the EMERGENCY COOL (HEAT) MODE.
6. When system stabilizes after more than 15 minutes, measure temperature and take an average temperature.
7. 10 minutes later, measure temperature again and check that the temperature does not change.

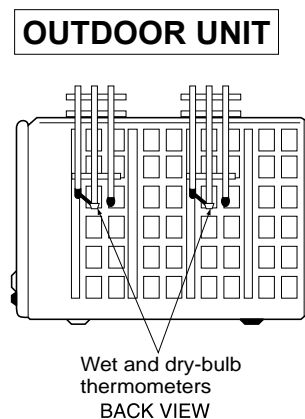
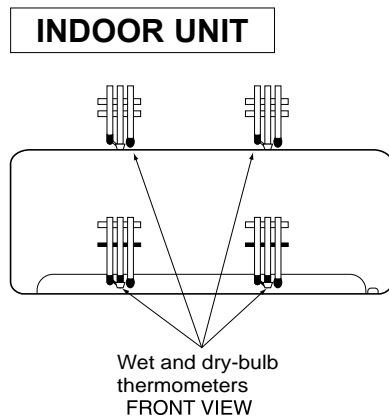

## 8-1. CAPACITY AND INPUT CURVES

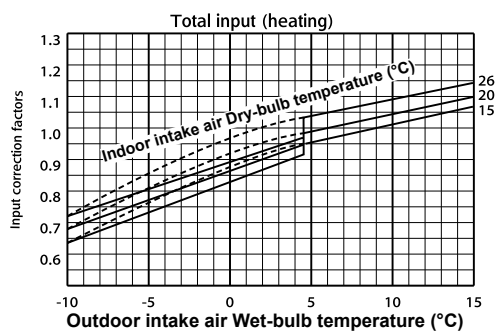
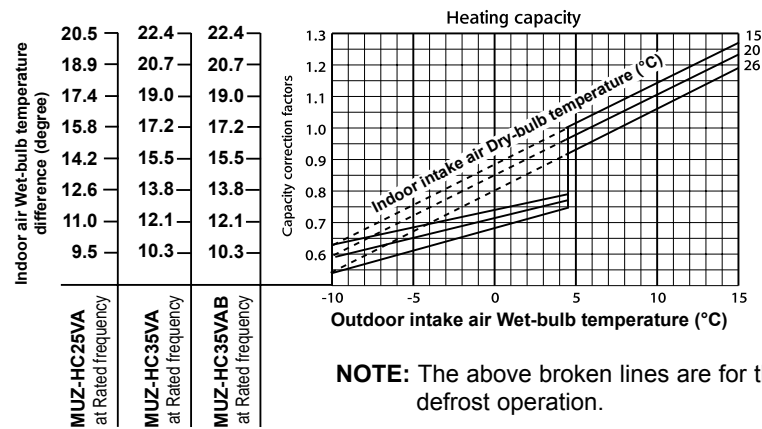
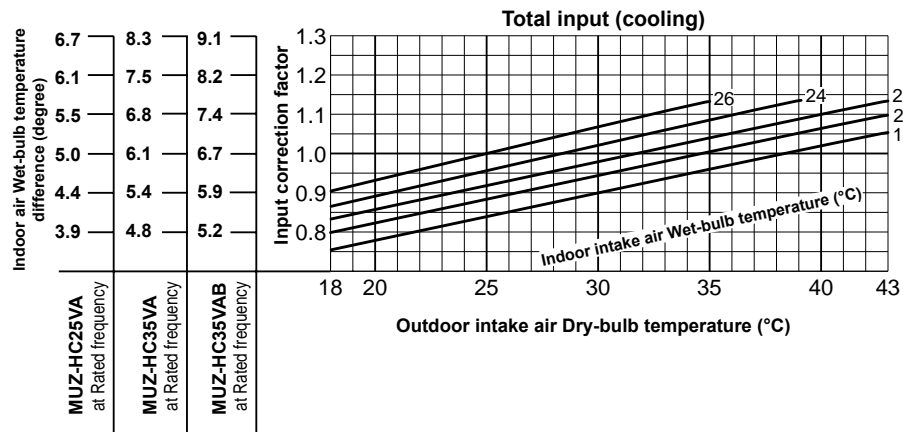
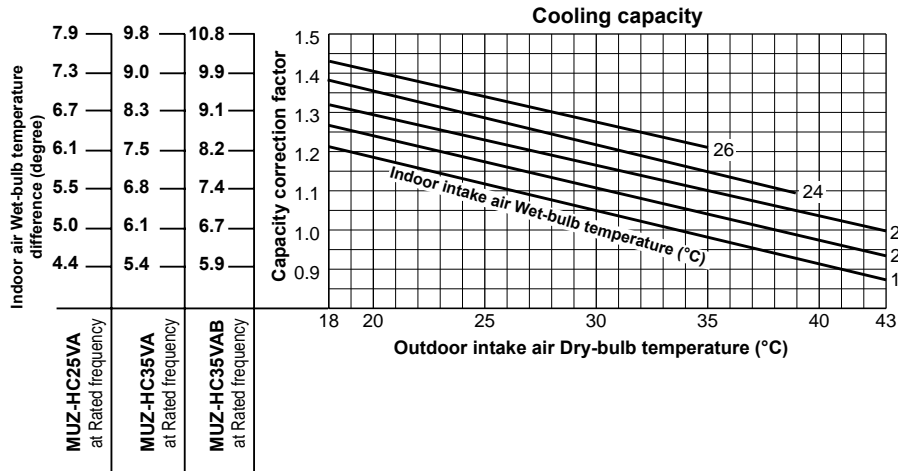

**NOTE:** The above broken lines are for the heating operation without any frost and defrost operation.

## 8-2. CAPACITY AND INPUT CORRECTION BY OPERATIONAL FREQUENCY OF COMPRESSOR

### MUZ-HC25VA

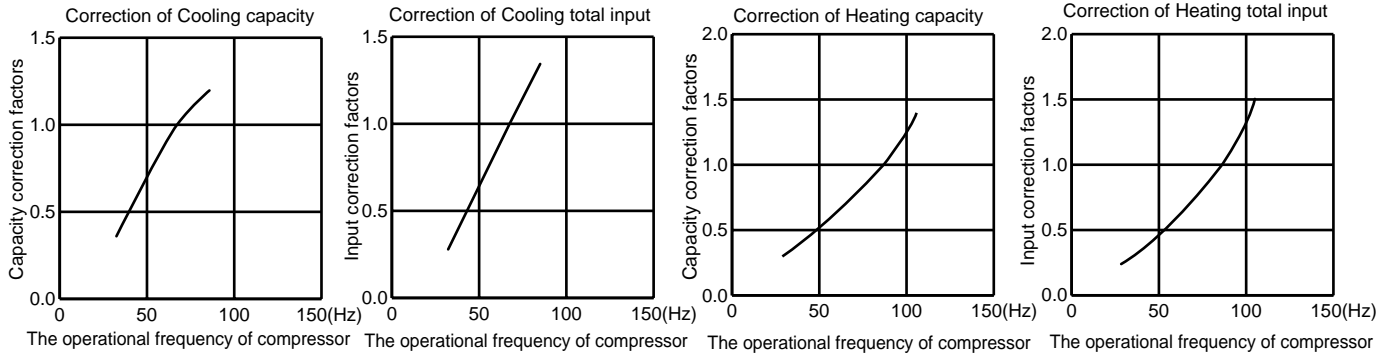

### MUZ-HC35VA

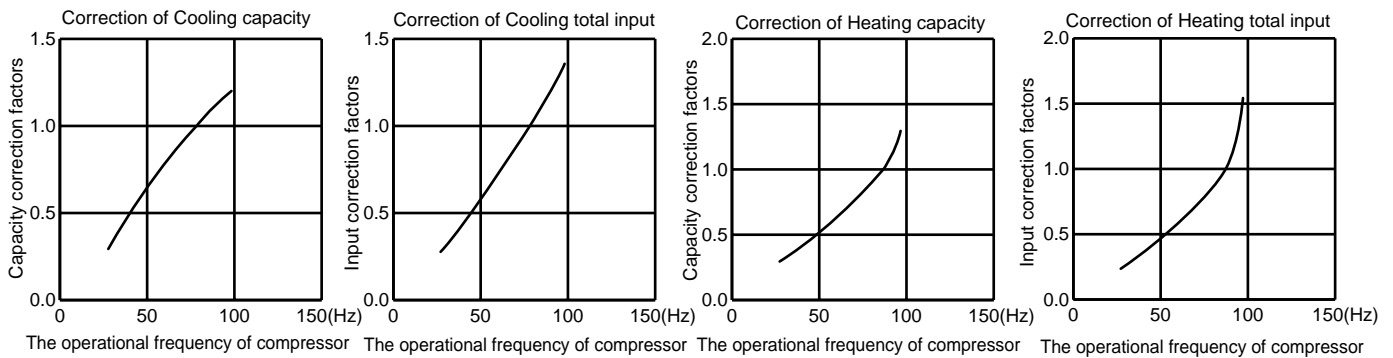

### MUZ-HC35VAB

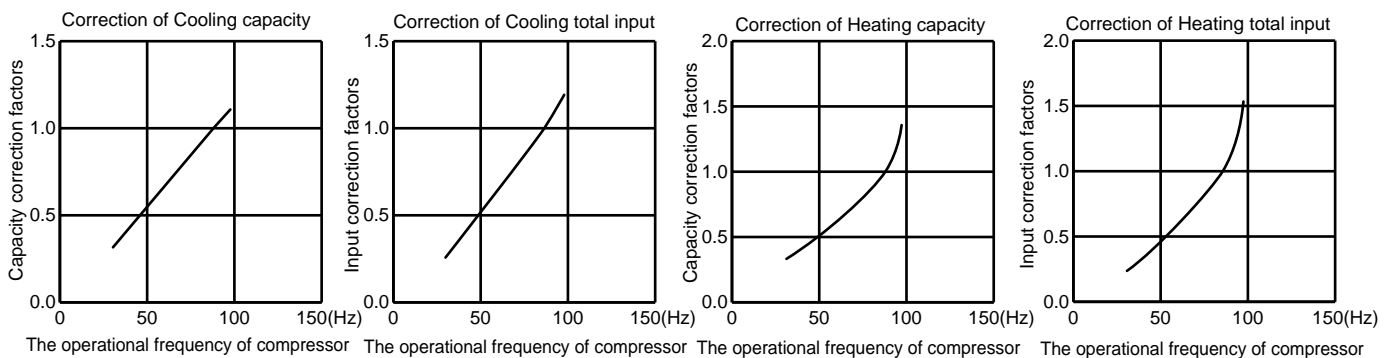

## 8-3. TEST RUN OPERATION (How to operate fixed-frequency operation)

1. Press EMERGENCY OPERATION switch to COOL or HEAT mode (COOL: Press once, HEAT: Press twice).
2. Test run operation starts and continues to operate for 30 minutes.
3. Compressor operates at rated frequency in COOL mode or 58 Hz in HEAT mode.
4. Indoor fan operates at High speed.
5. After 30 minutes, test run operation finishes and EMERGENCY OPERATION starts (Operation frequency of compressor varies).
6. To cancel test run operation (EMERGENCY OPERATION), press EMERGENCY OPERATION switch or any button on remote controller.

## 8-4. OUTDOOR LOW PRESSURE AND OUTDOOR UNIT CURRENT

### COOL operation

- ① Both indoor and outdoor unit are under the same temperature/humidity condition.
- ② Operation: TEST RUN OPERATION (Refer to 8-3.)

Dry-bulb temperature (°C)	Relative humidity (%)
20	50
25	60
30	70

#### Outdoor low pressure

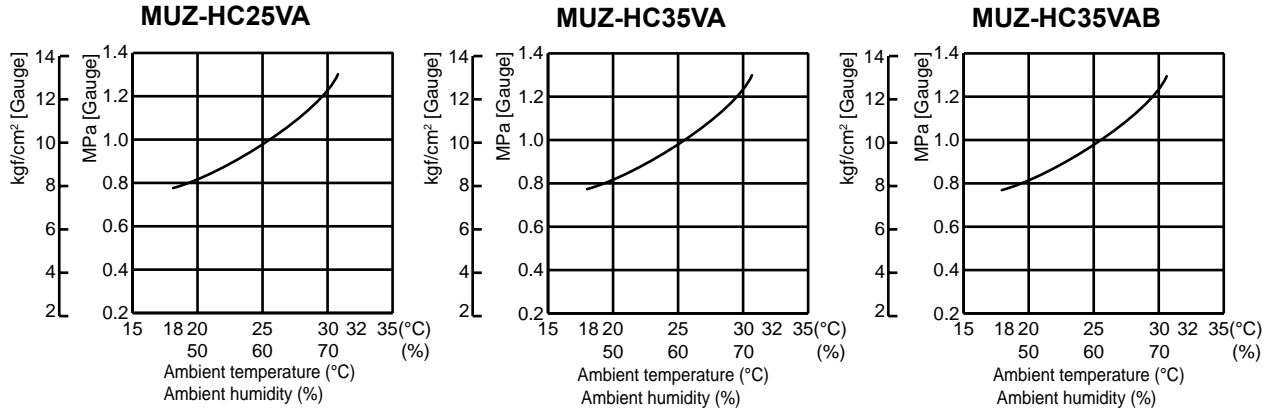

**NOTE :** The unit of pressure has been changed to MPa on the international system of units (SI unit system).  
The conversion factor is: **1 (MPa [Gauge]) = 10.2 (kgf/cm²[Gauge])**

#### Outdoor unit current

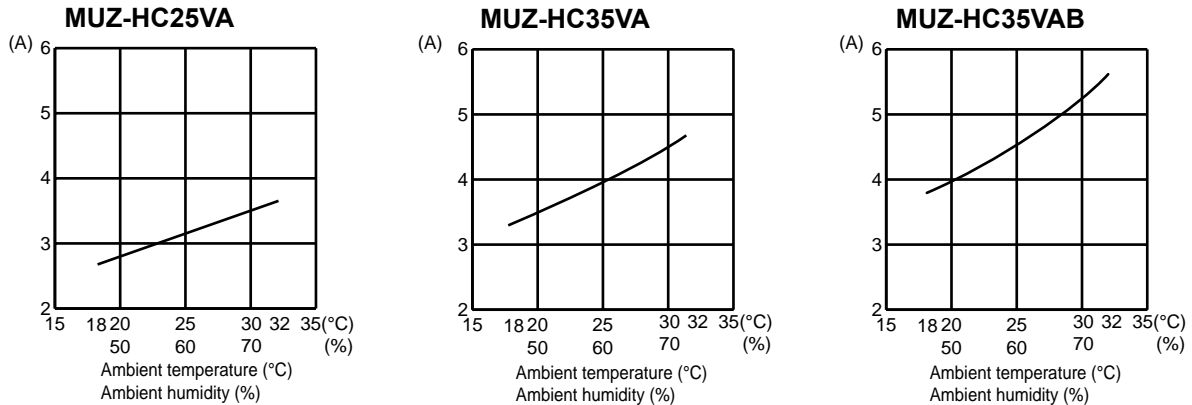

### HEAT operation

① Condition:

	Indoor	Outdoor			
Dry bulb temperature (°C)	20.0	2	7	15	20.0
Wet bulb temperature (°C)	14.5	1	6	12	14.5

- ② Operation: Test run operation (refer to 8-3.)

#### Outdoor unit current

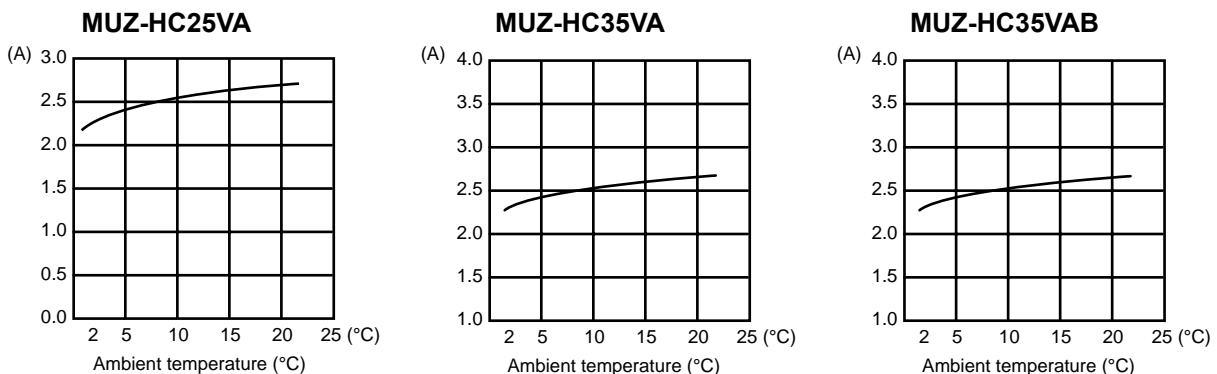



**PERFORMANCE DATA COOL operation at Rated frequency**

**MUZ-HC25VA**

CAPACITY: 2.5 kW

SHF: 0.79

INPUT: 770 W

INDOOR DB (°C)	INDOOR WB (°C)	OUTDOOR DB (°C)															
		21				25				27				30			
		Q	SHC	SHF	INPUT	Q	SHC	SHF	INPUT	Q	SHC	SHF	INPUT	Q	SHC	SHF	INPUT
21	18	2.94	1.79	0.61	616	2.81	1.72	0.61	647	2.70	1.65	0.61	678	2.60	1.59	0.61	708
21	20	3.06	1.50	0.49	647	2.94	1.44	0.49	685	2.85	1.40	0.49	701	2.75	1.35	0.49	732
22	18	2.94	1.91	0.65	616	2.81	1.83	0.65	647	2.70	1.76	0.65	678	2.60	1.69	0.65	708
22	20	3.06	1.62	0.53	647	2.94	1.56	0.53	685	2.85	1.51	0.53	701	2.75	1.46	0.53	732
22	22	3.19	1.31	0.41	670	3.08	1.26	0.41	712	3.00	1.23	0.41	732	2.88	1.18	0.41	762
23	18	2.94	2.03	0.69	616	2.81	1.94	0.69	647	2.70	1.86	0.69	678	2.60	1.79	0.69	708
23	20	3.06	1.75	0.57	647	2.94	1.67	0.57	685	2.85	1.62	0.57	701	2.75	1.57	0.57	732
23	22	3.19	1.43	0.45	670	3.08	1.38	0.45	712	3.00	1.35	0.45	732	2.88	1.29	0.45	762
24	18	2.94	2.14	0.73	616	2.81	2.05	0.73	647	2.70	1.97	0.73	678	2.60	1.90	0.73	708
24	20	3.06	1.87	0.61	647	2.94	1.79	0.61	685	2.85	1.74	0.61	701	2.75	1.68	0.61	732
24	22	3.19	1.56	0.49	670	3.08	1.51	0.49	712	3.00	1.47	0.49	732	2.88	1.41	0.49	762
24	24	3.35	1.24	0.37	701	3.23	1.19	0.37	739	3.15	1.17	0.37	762	3.05	1.13	0.37	801
25	18	2.94	2.26	0.77	616	2.81	2.17	0.77	647	2.70	2.08	0.77	678	2.60	2.00	0.77	708
25	20	3.06	1.99	0.65	647	2.94	1.91	0.65	685	2.85	1.85	0.65	701	2.75	1.79	0.65	732
25	22	3.19	1.69	0.53	670	3.08	1.63	0.53	712	3.00	1.59	0.53	732	2.88	1.52	0.53	762
25	24	3.35	1.37	0.41	701	3.23	1.32	0.41	739	3.15	1.29	0.41	762	3.05	1.25	0.41	801
26	18	2.94	2.38	0.81	616	2.81	2.28	0.81	647	2.70	2.19	0.81	678	2.60	2.11	0.81	708
26	20	3.06	2.11	0.69	647	2.94	2.03	0.69	685	2.85	1.97	0.69	701	2.75	1.90	0.69	732
26	22	3.19	1.82	0.57	670	3.08	1.75	0.57	712	3.00	1.71	0.57	732	2.88	1.64	0.57	762
26	24	3.35	1.51	0.45	701	3.23	1.45	0.45	739	3.15	1.42	0.45	762	3.05	1.37	0.45	801
26	26	3.45	1.14	0.33	739	3.35	1.11	0.33	778	3.30	1.09	0.33	801	3.20	1.06	0.33	824
27	18	2.94	2.50	0.85	616	2.81	2.39	0.85	647	2.70	2.30	0.85	678	2.60	2.21	0.85	708
27	20	3.06	2.24	0.73	647	2.94	2.14	0.73	685	2.85	2.08	0.73	701	2.75	2.01	0.73	732
27	22	3.19	1.94	0.61	670	3.08	1.88	0.61	712	3.00	1.83	0.61	732	2.88	1.75	0.61	762
27	24	3.35	1.64	0.49	701	3.23	1.58	0.49	739	3.15	1.54	0.49	762	3.05	1.49	0.49	801
27	26	3.45	1.28	0.37	739	3.35	1.24	0.37	778	3.30	1.22	0.37	801	3.20	1.18	0.37	824
28	18	2.94	2.61	0.89	616	2.81	2.50	0.89	647	2.70	2.40	0.89	678	2.60	2.31	0.89	708
28	20	3.06	2.36	0.77	647	2.94	2.26	0.77	685	2.85	2.19	0.77	701	2.75	2.12	0.77	732
28	22	3.19	2.07	0.65	670	3.08	2.00	0.65	712	3.00	1.95	0.65	732	2.88	1.87	0.65	762
28	24	3.35	1.78	0.53	701	3.23	1.71	0.53	739	3.15	1.67	0.53	762	3.05	1.62	0.53	801
28	26	3.45	1.41	0.41	739	3.35	1.37	0.41	778	3.30	1.35	0.41	801	3.20	1.31	0.41	824
29	18	2.94	2.73	0.93	616	2.81	2.62	0.93	647	2.70	2.51	0.93	678	2.60	2.42	0.93	708
29	20	3.06	2.48	0.81	647	2.94	2.38	0.81	685	2.85	2.31	0.81	701	2.75	2.23	0.81	732
29	22	3.19	2.20	0.69	670	3.08	2.12	0.69	712	3.00	2.07	0.69	732	2.88	1.98	0.69	762
29	24	3.35	1.91	0.57	701	3.23	1.84	0.57	739	3.15	1.80	0.57	762	3.05	1.74	0.57	801
29	26	3.45	1.55	0.45	739	3.35	1.51	0.45	778	3.30	1.49	0.45	801	3.20	1.44	0.45	824
30	18	2.94	2.85	0.97	616	2.81	2.73	0.97	647	2.70	2.62	0.97	678	2.60	2.52	0.97	708
30	20	3.06	2.60	0.85	647	2.94	2.50	0.85	685	2.85	2.42	0.85	701	2.75	2.34	0.85	732
30	22	3.19	2.33	0.73	670	3.08	2.24	0.73	712	3.00	2.19	0.73	732	2.88	2.10	0.73	762
30	24	3.35	2.04	0.61	701	3.23	1.97	0.61	739	3.15	1.92	0.61	762	3.05	1.86	0.61	801
30	26	3.45	1.69	0.49	739	3.35	1.64	0.49	778	3.30	1.62	0.49	801	3.20	1.57	0.49	824
31	18	2.94	2.94	1.00	616	2.81	2.81	1.00	647	2.70	2.70	1.00	678	2.60	2.60	1.00	708
31	20	3.06	2.73	0.89	647	2.94	2.61	0.89	685	2.85	2.54	0.89	701	2.75	2.45	0.89	732
31	22	3.19	2.45	0.77	670	3.08	2.37	0.77	712	3.00	2.31	0.77	732	2.88	2.21	0.77	762
31	24	3.35	2.18	0.65	701	3.23	2.10	0.65	739	3.15	2.05	0.65	762	3.05	1.98	0.65	801
31	26	3.45	1.83	0.53	739	3.35	1.78	0.53	778	3.30	1.75	0.53	801	3.20	1.70	0.53	824
32	18	2.94	2.94	1.00	616	2.81	2.81	1.00	647	2.70	2.70	1.00	678	2.60	2.60	1.00	708
32	20	3.06	2.85	0.93	647	2.94	2.73	0.93	685	2.85	2.65	0.93	701	2.75	2.56	0.93	732
32	22	3.19	2.58	0.81	670	3.08	2.49	0.81	712	3.00	2.43	0.81	732	2.88	2.33	0.81	762
32	24	3.35	2.31	0.69	701	3.23	2.23	0.69	739	3.15	2.17	0.69	762	3.05	2.10	0.69	801
32	26	3.45	1.97	0.57	739	3.35	1.91	0.57	778	3.30	1.88	0.57	801	3.20	1.82	0.57	824

**NOTE** Q : Total capacity (kW) SHF : Sensible heat factor DB : Dry-bulb temperature  
 SHC : Sensible heat capacity (kW) INPUT : Total power input (W) WB : Wet-bulb temperature

**PERFORMANCE DATA COOL operation at Rated frequency**

**MUZ-HC25VA**

CAPACITY: 2.5 kW

SHF: 0.79

INPUT: 770 W

INDOOR DB (°C)	INDOOR WB (°C)	OUTDOOR DB (°C)											
		35				40				46			
		Q	SHC	SHF	INPUT	Q	SHC	SHF	INPUT	Q	SHC	SHF	INPUT
21	18	2.45	1.49	0.61	755	2.25	1.37	0.61	801	2.08	1.27	0.61	832
21	20	2.58	1.26	0.49	785	2.40	1.18	0.49	824	2.23	1.09	0.49	870
22	18	2.45	1.59	0.65	755	2.25	1.46	0.65	801	2.08	1.35	0.65	832
22	20	2.58	1.36	0.53	785	2.40	1.27	0.53	824	2.23	1.18	0.53	870
22	22	2.73	1.12	0.41	816	2.55	1.05	0.41	862	2.38	0.97	0.41	893
23	18	2.45	1.69	0.69	755	2.25	1.55	0.69	801	2.08	1.43	0.69	832
23	20	2.58	1.47	0.57	785	2.40	1.37	0.57	824	2.23	1.27	0.57	870
23	22	2.73	1.23	0.45	816	2.55	1.15	0.45	862	2.38	1.07	0.45	893
24	18	2.45	1.79	0.73	755	2.25	1.64	0.73	801	2.08	1.51	0.73	832
24	20	2.58	1.57	0.61	785	2.40	1.46	0.61	824	2.23	1.36	0.61	870
24	22	2.73	1.34	0.49	816	2.55	1.25	0.49	862	2.38	1.16	0.49	893
24	24	2.88	1.06	0.37	847	2.70	1.00	0.37	886	2.55	0.94	0.37	924
25	18	2.45	1.89	0.77	755	2.25	1.73	0.77	801	2.08	1.60	0.77	832
25	20	2.58	1.67	0.65	785	2.40	1.56	0.65	824	2.23	1.45	0.65	870
25	22	2.73	1.44	0.53	816	2.55	1.35	0.53	862	2.38	1.26	0.53	893
25	24	2.88	1.18	0.41	847	2.70	1.11	0.41	886	2.55	1.05	0.41	924
26	18	2.45	1.98	0.81	755	2.25	1.82	0.81	801	2.08	1.68	0.81	832
26	20	2.58	1.78	0.69	785	2.40	1.66	0.69	824	2.23	1.54	0.69	870
26	22	2.73	1.55	0.57	816	2.55	1.45	0.57	862	2.38	1.35	0.57	893
26	24	2.88	1.29	0.45	847	2.70	1.22	0.45	886	2.55	1.15	0.45	924
26	26	3.03	1.00	0.33	878	2.85	0.94	0.33	916	2.68	0.88	0.33	955
27	18	2.45	2.08	0.85	755	2.25	1.91	0.85	801	2.08	1.76	0.85	832
27	20	2.58	1.88	0.73	785	2.40	1.75	0.73	824	2.23	1.62	0.73	870
27	22	2.73	1.66	0.61	816	2.55	1.56	0.61	862	2.38	1.45	0.61	893
27	24	2.88	1.41	0.49	847	2.70	1.32	0.49	886	2.55	1.25	0.49	924
27	26	3.03	1.12	0.37	878	2.85	1.05	0.37	916	2.68	0.99	0.37	955
28	18	2.45	2.18	0.89	755	2.25	2.00	0.89	801	2.08	1.85	0.89	832
28	20	2.58	1.98	0.77	785	2.40	1.85	0.77	824	2.23	1.71	0.77	870
28	22	2.73	1.77	0.65	816	2.55	1.66	0.65	862	2.38	1.54	0.65	893
28	24	2.88	1.52	0.53	847	2.70	1.43	0.53	886	2.55	1.35	0.53	924
28	26	3.03	1.24	0.41	878	2.85	1.17	0.41	916	2.68	1.10	0.41	955
29	18	2.45	2.28	0.93	755	2.25	2.09	0.93	801	2.08	1.93	0.93	832
29	20	2.58	2.09	0.81	785	2.40	1.94	0.81	824	2.23	1.80	0.81	870
29	22	2.73	1.88	0.69	816	2.55	1.76	0.69	862	2.38	1.64	0.69	893
29	24	2.88	1.64	0.57	847	2.70	1.54	0.57	886	2.55	1.45	0.57	924
29	26	3.03	1.36	0.45	878	2.85	1.28	0.45	916	2.68	1.20	0.45	955
30	18	2.45	2.38	0.97	755	2.25	2.18	0.97	801	2.08	2.01	0.97	832
30	20	2.58	2.19	0.85	785	2.40	2.04	0.85	824	2.23	1.89	0.85	870
30	22	2.73	1.99	0.73	816	2.55	1.86	0.73	862	2.38	1.73	0.73	893
30	24	2.88	1.75	0.61	847	2.70	1.65	0.61	886	2.55	1.56	0.61	924
30	26	3.03	1.48	0.49	878	2.85	1.40	0.49	916	2.68	1.31	0.49	955
31	18	2.45	2.45	1.00	755	2.25	2.25	1.00	801	2.08	2.08	1.00	832
31	20	2.58	2.29	0.89	785	2.40	2.14	0.89	824	2.23	1.98	0.89	870
31	22	2.73	2.10	0.77	816	2.55	1.96	0.77	862	2.38	1.83	0.77	893
31	24	2.88	1.87	0.65	847	2.70	1.76	0.65	886	2.55	1.66	0.65	924
31	26	3.03	1.60	0.53	878	2.85	1.51	0.53	916	2.68	1.42	0.53	955
32	18	2.45	2.45	1.00	755	2.25	2.25	1.00	801	2.08	2.08	1.00	832
32	20	2.58	2.39	0.93	785	2.40	2.23	0.93	824	2.23	2.07	0.93	870
32	22	2.73	2.21	0.81	816	2.55	2.07	0.81	862	2.38	1.92	0.81	893
32	24	2.88	1.98	0.69	847	2.70	1.86	0.69	886	2.55	1.76	0.69	924
32	26	3.03	1.72	0.57	878	2.85	1.62	0.57	916	2.68	1.52	0.57	955

**NOTE** Q : Total capacity (kW) SHF : Sensible heat factor DB : Dry-bulb temperature  
 SHC : Sensible heat capacity (kW) INPUT : Total power input (W) WB : Wet-bulb temperature

**PERFORMANCE DATA COOL operation at Rated frequency**

**MUZ-HC35VA**

CAPACITY: 3.15 kW

SHF: 0.76

INPUT: 980 W

INDOOR DB (°C)	INDOOR WB (°C)	OUTDOOR DB (°C)															
		21				25				27				30			
		Q	SHC	SHF	INPUT	Q	SHC	SHF	INPUT	Q	SHC	SHF	INPUT	Q	SHC	SHF	INPUT
21	18	3.70	2.15	0.58	784	3.54	2.06	0.58	823	3.40	1.97	0.58	862	3.28	1.90	0.58	902
21	20	3.86	1.78	0.46	823	3.70	1.70	0.46	872	3.59	1.65	0.46	892	3.47	1.59	0.46	931
22	18	3.70	2.29	0.62	784	3.54	2.20	0.62	823	3.40	2.11	0.62	862	3.28	2.03	0.62	902
22	20	3.86	1.93	0.50	823	3.70	1.85	0.50	872	3.59	1.80	0.50	892	3.47	1.73	0.50	931
22	22	4.02	1.53	0.38	853	3.87	1.47	0.38	907	3.78	1.44	0.38	931	3.62	1.38	0.38	970
23	18	3.70	2.44	0.66	784	3.54	2.34	0.66	823	3.40	2.25	0.66	862	3.28	2.16	0.66	902
23	20	3.86	2.08	0.54	823	3.70	2.00	0.54	872	3.59	1.94	0.54	892	3.47	1.87	0.54	931
23	22	4.02	1.69	0.42	853	3.87	1.63	0.42	907	3.78	1.59	0.42	931	3.62	1.52	0.42	970
24	18	3.70	2.59	0.70	784	3.54	2.48	0.70	823	3.40	2.38	0.70	862	3.28	2.29	0.70	902
24	20	3.86	2.24	0.58	823	3.70	2.15	0.58	872	3.59	2.08	0.58	892	3.47	2.01	0.58	931
24	22	4.02	1.85	0.46	853	3.87	1.78	0.46	907	3.78	1.74	0.46	931	3.62	1.67	0.46	970
24	24	4.22	1.44	0.34	892	4.06	1.38	0.34	941	3.97	1.35	0.34	970	3.84	1.31	0.34	1019
25	18	3.70	2.74	0.74	784	3.54	2.62	0.74	823	3.40	2.52	0.74	862	3.28	2.42	0.74	902
25	20	3.86	2.39	0.62	823	3.70	2.29	0.62	872	3.59	2.23	0.62	892	3.47	2.15	0.62	931
25	22	4.02	2.01	0.50	853	3.87	1.94	0.50	907	3.78	1.89	0.50	931	3.62	1.81	0.50	970
25	24	4.22	1.60	0.38	892	4.06	1.54	0.38	941	3.97	1.51	0.38	970	3.84	1.46	0.38	1019
26	18	3.70	2.89	0.78	784	3.54	2.76	0.78	823	3.40	2.65	0.78	862	3.28	2.56	0.78	902
26	20	3.86	2.55	0.66	823	3.70	2.44	0.66	872	3.59	2.37	0.66	892	3.47	2.29	0.66	931
26	22	4.02	2.17	0.54	853	3.87	2.09	0.54	907	3.78	2.04	0.54	931	3.62	1.96	0.54	970
26	24	4.22	1.77	0.42	892	4.06	1.71	0.42	941	3.97	1.67	0.42	970	3.84	1.61	0.42	1019
26	26	4.35	1.30	0.30	941	4.22	1.27	0.30	990	4.16	1.25	0.30	1019	4.03	1.21	0.30	1049
27	18	3.70	3.04	0.82	784	3.54	2.91	0.82	823	3.40	2.79	0.82	862	3.28	2.69	0.82	902
27	20	3.86	2.70	0.70	823	3.70	2.59	0.70	872	3.59	2.51	0.70	892	3.47	2.43	0.70	931
27	22	4.02	2.33	0.58	853	3.87	2.25	0.58	907	3.78	2.19	0.58	931	3.62	2.10	0.58	970
27	24	4.22	1.94	0.46	892	4.06	1.87	0.46	941	3.97	1.83	0.46	970	3.84	1.77	0.46	1019
27	26	4.35	1.48	0.34	941	4.22	1.44	0.34	990	4.16	1.41	0.34	1019	4.03	1.37	0.34	1049
28	18	3.70	3.18	0.86	784	3.54	3.05	0.86	823	3.40	2.93	0.86	862	3.28	2.82	0.86	902
28	20	3.86	2.86	0.74	823	3.70	2.74	0.74	872	3.59	2.66	0.74	892	3.47	2.56	0.74	931
28	22	4.02	2.49	0.62	853	3.87	2.40	0.62	907	3.78	2.34	0.62	931	3.62	2.25	0.62	970
28	24	4.22	2.11	0.50	892	4.06	2.03	0.50	941	3.97	1.98	0.50	970	3.84	1.92	0.50	1019
28	26	4.35	1.65	0.38	941	4.22	1.60	0.38	990	4.16	1.58	0.38	1019	4.03	1.53	0.38	1049
29	18	3.70	3.33	0.90	784	3.54	3.19	0.90	823	3.40	3.06	0.90	862	3.28	2.95	0.90	902
29	20	3.86	3.01	0.78	823	3.70	2.89	0.78	872	3.59	2.80	0.78	892	3.47	2.70	0.78	931
29	22	4.02	2.65	0.66	853	3.87	2.56	0.66	907	3.78	2.49	0.66	931	3.62	2.39	0.66	970
29	24	4.22	2.28	0.54	892	4.06	2.19	0.54	941	3.97	2.14	0.54	970	3.84	2.08	0.54	1019
29	26	4.35	1.83	0.42	941	4.22	1.77	0.42	990	4.16	1.75	0.42	1019	4.03	1.69	0.42	1049
30	18	3.70	3.48	0.94	784	3.54	3.33	0.94	823	3.40	3.20	0.94	862	3.28	3.08	0.94	902
30	20	3.86	3.16	0.82	823	3.70	3.04	0.82	872	3.59	2.94	0.82	892	3.47	2.84	0.82	931
30	22	4.02	2.81	0.70	853	3.87	2.71	0.70	907	3.78	2.65	0.70	931	3.62	2.54	0.70	970
30	24	4.22	2.45	0.58	892	4.06	2.36	0.58	941	3.97	2.30	0.58	970	3.84	2.23	0.58	1019
30	26	4.35	2.00	0.46	941	4.22	1.94	0.46	990	4.16	1.91	0.46	1019	4.03	1.85	0.46	1049
31	18	3.70	3.63	0.98	784	3.54	3.47	0.98	823	3.40	3.33	0.98	862	3.28	3.21	0.98	902
31	20	3.86	3.32	0.86	823	3.70	3.18	0.86	872	3.59	3.09	0.86	892	3.47	2.98	0.86	931
31	22	4.02	2.97	0.74	853	3.87	2.87	0.74	907	3.78	2.80	0.74	931	3.62	2.68	0.74	970
31	24	4.22	2.62	0.62	892	4.06	2.52	0.62	941	3.97	2.46	0.62	970	3.84	2.38	0.62	1019
31	26	4.35	2.17	0.50	941	4.22	2.11	0.50	990	4.16	2.08	0.50	1019	4.03	2.02	0.50	1049
32	18	3.70	3.70	1.00	784	3.54	3.54	1.00	823	3.40	3.40	1.00	862	3.28	3.28	1.00	902
32	20	3.86	3.47	0.90	823	3.70	3.33	0.90	872	3.59	3.23	0.90	892	3.47	3.12	0.90	931
32	22	4.02	3.13	0.78	853	3.87	3.02	0.78	907	3.78	2.95	0.78	931	3.62	2.83	0.78	970
32	24	4.22	2.79	0.66	892	4.06	2.68	0.66	941	3.97	2.62	0.66	970	3.84	2.54	0.66	1019
32	26	4.35	2.35	0.54	941	4.22	2.28	0.54	990	4.16	2.25	0.54	1019	4.03	2.18	0.54	1049

**NOTE** Q : Total capacity (kW) SHF : Sensible heat factor DB : Dry-bulb temperature  
 SHC : Sensible heat capacity (kW) INPUT : Total power input (W) WB : Wet-bulb temperature

**PERFORMANCE DATA COOL operation at Rated frequency**

**MUZ-HC35VA**

CAPACITY: 3.15 kW

SHF: 0.76

INPUT: 980 W

INDOOR DB (°C)	INDOOR WB (°C)	OUTDOOR DB (°C)											
		35				40				46			
		Q	SHC	SHF	INPUT	Q	SHC	SHF	INPUT	Q	SHC	SHF	INPUT
21	18	3.09	1.79	0.58	960	2.84	1.64	0.58	1019	2.61	1.52	0.58	1058
21	20	3.24	1.49	0.46	1000	3.02	1.39	0.46	1049	2.80	1.29	0.46	1107
22	18	3.09	1.91	0.62	960	2.84	1.76	0.62	1019	2.61	1.62	0.62	1058
22	20	3.24	1.62	0.50	1000	3.02	1.51	0.50	1049	2.80	1.40	0.50	1107
22	22	3.43	1.30	0.38	1039	3.21	1.22	0.38	1098	2.99	1.14	0.38	1137
23	18	3.09	2.04	0.66	960	2.84	1.87	0.66	1019	2.61	1.73	0.66	1058
23	20	3.24	1.75	0.54	1000	3.02	1.63	0.54	1049	2.80	1.51	0.54	1107
23	22	3.43	1.44	0.42	1039	3.21	1.35	0.42	1098	2.99	1.26	0.42	1137
24	18	3.09	2.16	0.70	960	2.84	1.98	0.70	1019	2.61	1.83	0.70	1058
24	20	3.24	1.88	0.58	1000	3.02	1.75	0.58	1049	2.80	1.63	0.58	1107
24	22	3.43	1.58	0.46	1039	3.21	1.48	0.46	1098	2.99	1.38	0.46	1137
24	24	3.62	1.23	0.34	1078	3.40	1.16	0.34	1127	3.21	1.09	0.34	1176
25	18	3.09	2.28	0.74	960	2.84	2.10	0.74	1019	2.61	1.93	0.74	1058
25	20	3.24	2.01	0.62	1000	3.02	1.87	0.62	1049	2.80	1.74	0.62	1107
25	22	3.43	1.72	0.50	1039	3.21	1.61	0.50	1098	2.99	1.50	0.50	1137
25	24	3.62	1.38	0.38	1078	3.40	1.29	0.38	1127	3.21	1.22	0.38	1176
26	18	3.09	2.41	0.78	960	2.84	2.21	0.78	1019	2.61	2.04	0.78	1058
26	20	3.24	2.14	0.66	1000	3.02	2.00	0.66	1049	2.80	1.85	0.66	1107
26	22	3.43	1.85	0.54	1039	3.21	1.74	0.54	1098	2.99	1.62	0.54	1137
26	24	3.62	1.52	0.42	1078	3.40	1.43	0.42	1127	3.21	1.35	0.42	1176
26	26	3.81	1.14	0.30	1117	3.59	1.08	0.30	1166	3.37	1.01	0.30	1215
27	18	3.09	2.53	0.82	960	2.84	2.32	0.82	1019	2.61	2.14	0.82	1058
27	20	3.24	2.27	0.70	1000	3.02	2.12	0.70	1049	2.80	1.96	0.70	1107
27	22	3.43	1.99	0.58	1039	3.21	1.86	0.58	1098	2.99	1.74	0.58	1137
27	24	3.62	1.67	0.46	1078	3.40	1.56	0.46	1127	3.21	1.48	0.46	1176
27	26	3.81	1.30	0.34	1117	3.59	1.22	0.34	1166	3.37	1.15	0.34	1215
28	18	3.09	2.65	0.86	960	2.84	2.44	0.86	1019	2.61	2.25	0.86	1058
28	20	3.24	2.40	0.74	1000	3.02	2.24	0.74	1049	2.80	2.07	0.74	1107
28	22	3.43	2.13	0.62	1039	3.21	1.99	0.62	1098	2.99	1.86	0.62	1137
28	24	3.62	1.81	0.50	1078	3.40	1.70	0.50	1127	3.21	1.61	0.50	1176
28	26	3.81	1.45	0.38	1117	3.59	1.36	0.38	1166	3.37	1.28	0.38	1215
29	18	3.09	2.78	0.90	960	2.84	2.55	0.90	1019	2.61	2.35	0.90	1058
29	20	3.24	2.53	0.78	1000	3.02	2.36	0.78	1049	2.80	2.19	0.78	1107
29	22	3.43	2.27	0.66	1039	3.21	2.12	0.66	1098	2.99	1.98	0.66	1137
29	24	3.62	1.96	0.54	1078	3.40	1.84	0.54	1127	3.21	1.74	0.54	1176
29	26	3.81	1.60	0.42	1117	3.59	1.51	0.42	1166	3.37	1.42	0.42	1215
30	18	3.09	2.90	0.94	960	2.84	2.66	0.94	1019	2.61	2.46	0.94	1058
30	20	3.24	2.66	0.82	1000	3.02	2.48	0.82	1049	2.80	2.30	0.82	1107
30	22	3.43	2.40	0.70	1039	3.21	2.25	0.70	1098	2.99	2.09	0.70	1137
30	24	3.62	2.10	0.58	1078	3.40	1.97	0.58	1127	3.21	1.86	0.58	1176
30	26	3.81	1.75	0.46	1117	3.59	1.65	0.46	1166	3.37	1.55	0.46	1215
31	18	3.09	3.03	0.98	960	2.84	2.78	0.98	1019	2.61	2.56	0.98	1058
31	20	3.24	2.79	0.86	1000	3.02	2.60	0.86	1049	2.80	2.41	0.86	1107
31	22	3.43	2.54	0.74	1039	3.21	2.38	0.74	1098	2.99	2.21	0.74	1137
31	24	3.62	2.25	0.62	1078	3.40	2.11	0.62	1127	3.21	1.99	0.62	1176
31	26	3.81	1.91	0.50	1117	3.59	1.80	0.50	1166	3.37	1.69	0.50	1215
32	18	3.09	3.09	1.00	960	2.84	2.84	1.00	1019	2.61	2.61	1.00	1058
32	20	3.24	2.92	0.90	1000	3.02	2.72	0.90	1049	2.80	2.52	0.90	1107
32	22	3.43	2.68	0.78	1039	3.21	2.51	0.78	1098	2.99	2.33	0.78	1137
32	24	3.62	2.39	0.66	1078	3.40	2.25	0.66	1127	3.21	2.12	0.66	1176
32	26	3.81	2.06	0.54	1117	3.59	1.94	0.54	1166	3.37	1.82	0.54	1215

**NOTE** Q : Total capacity (kW) SHF : Sensible heat factor DB : Dry-bulb temperature  
 SHC : Sensible heat capacity (kW) INPUT : Total power input (W) WB : Wet-bulb temperature

**PERFORMANCE DATA COOL operation at Rated frequency**

**MUZ-HC35VAB**

CAPACITY: 3.4 kW

SHF: 0.76

INPUT: 1130 W

INDOOR DB (°C)	INDOOR WB (°C)	OUTDOOR DB (°C)															
		21				25				27				30			
		Q	SHC	SHF	INPUT	Q	SHC	SHF	INPUT	Q	SHC	SHF	INPUT	Q	SHC	SHF	INPUT
21	18	4.00	2.32	0.58	904	3.83	2.22	0.58	949	3.67	2.13	0.58	994	3.54	2.05	0.58	1040
21	20	4.17	1.92	0.46	949	4.00	1.84	0.46	1006	3.88	1.78	0.46	1028	3.74	1.72	0.46	1074
22	18	4.00	2.48	0.62	904	3.83	2.37	0.62	949	3.67	2.28	0.62	994	3.54	2.19	0.62	1040
22	20	4.17	2.08	0.50	949	4.00	2.00	0.50	1006	3.88	1.94	0.50	1028	3.74	1.87	0.50	1074
22	22	4.34	1.65	0.38	983	4.18	1.59	0.38	1045	4.08	1.55	0.38	1074	3.91	1.49	0.38	1119
23	18	4.00	2.64	0.66	904	3.83	2.52	0.66	949	3.67	2.42	0.66	994	3.54	2.33	0.66	1040
23	20	4.17	2.25	0.54	949	4.00	2.16	0.54	1006	3.88	2.09	0.54	1028	3.74	2.02	0.54	1074
23	22	4.34	1.82	0.42	983	4.18	1.76	0.42	1045	4.08	1.71	0.42	1074	3.91	1.64	0.42	1119
24	18	4.00	2.80	0.70	904	3.83	2.68	0.70	949	3.67	2.57	0.70	994	3.54	2.48	0.70	1040
24	20	4.17	2.42	0.58	949	4.00	2.32	0.58	1006	3.88	2.25	0.58	1028	3.74	2.17	0.58	1074
24	22	4.34	1.99	0.46	983	4.18	1.92	0.46	1045	4.08	1.88	0.46	1074	3.91	1.80	0.46	1119
24	24	4.56	1.55	0.34	1028	4.39	1.49	0.34	1085	4.28	1.46	0.34	1119	4.15	1.41	0.34	1175
25	18	4.00	2.96	0.74	904	3.83	2.83	0.74	949	3.67	2.72	0.74	994	3.54	2.62	0.74	1040
25	20	4.17	2.58	0.62	949	4.00	2.48	0.62	1006	3.88	2.40	0.62	1028	3.74	2.32	0.62	1074
25	22	4.34	2.17	0.50	983	4.18	2.09	0.50	1045	4.08	2.04	0.50	1074	3.91	1.96	0.50	1119
25	24	4.56	1.73	0.38	1028	4.39	1.67	0.38	1085	4.28	1.63	0.38	1119	4.15	1.58	0.38	1175
26	18	4.00	3.12	0.78	904	3.83	2.98	0.78	949	3.67	2.86	0.78	994	3.54	2.76	0.78	1040
26	20	4.17	2.75	0.66	949	4.00	2.64	0.66	1006	3.88	2.56	0.66	1028	3.74	2.47	0.66	1074
26	22	4.34	2.34	0.54	983	4.18	2.26	0.54	1045	4.08	2.20	0.54	1074	3.91	2.11	0.54	1119
26	24	4.56	1.91	0.42	1028	4.39	1.84	0.42	1085	4.28	1.80	0.42	1119	4.15	1.74	0.42	1175
26	26	4.69	1.41	0.30	1085	4.56	1.37	0.30	1141	4.49	1.35	0.30	1175	4.35	1.31	0.30	1209
27	18	4.00	3.28	0.82	904	3.83	3.14	0.82	949	3.67	3.01	0.82	994	3.54	2.90	0.82	1040
27	20	4.17	2.92	0.70	949	4.00	2.80	0.70	1006	3.88	2.71	0.70	1028	3.74	2.62	0.70	1074
27	22	4.34	2.51	0.58	983	4.18	2.43	0.58	1045	4.08	2.37	0.58	1074	3.91	2.27	0.58	1119
27	24	4.56	2.10	0.46	1028	4.39	2.02	0.46	1085	4.28	1.97	0.46	1119	4.15	1.91	0.46	1175
27	26	4.69	1.60	0.34	1085	4.56	1.55	0.34	1141	4.49	1.53	0.34	1175	4.35	1.48	0.34	1209
28	18	4.00	3.44	0.86	904	3.83	3.29	0.86	949	3.67	3.16	0.86	994	3.54	3.04	0.86	1040
28	20	4.17	3.08	0.74	949	4.00	2.96	0.74	1006	3.88	2.87	0.74	1028	3.74	2.77	0.74	1074
28	22	4.34	2.69	0.62	983	4.18	2.59	0.62	1045	4.08	2.53	0.62	1074	3.91	2.42	0.62	1119
28	24	4.56	2.28	0.50	1028	4.39	2.19	0.50	1085	4.28	2.14	0.50	1119	4.15	2.07	0.50	1175
28	26	4.69	1.78	0.38	1085	4.56	1.73	0.38	1141	4.49	1.71	0.38	1175	4.35	1.65	0.38	1209
29	18	4.00	3.60	0.90	904	3.83	3.44	0.90	949	3.67	3.30	0.90	994	3.54	3.18	0.90	1040
29	20	4.17	3.25	0.78	949	4.00	3.12	0.78	1006	3.88	3.02	0.78	1028	3.74	2.92	0.78	1074
29	22	4.34	2.86	0.66	983	4.18	2.76	0.66	1045	4.08	2.69	0.66	1074	3.91	2.58	0.66	1119
29	24	4.56	2.46	0.54	1028	4.39	2.37	0.54	1085	4.28	2.31	0.54	1119	4.15	2.24	0.54	1175
29	26	4.69	1.97	0.42	1085	4.56	1.91	0.42	1141	4.49	1.88	0.42	1175	4.35	1.83	0.42	1209
30	18	4.00	3.76	0.94	904	3.83	3.60	0.94	949	3.67	3.45	0.94	994	3.54	3.32	0.94	1040
30	20	4.17	3.42	0.82	949	4.00	3.28	0.82	1006	3.88	3.18	0.82	1028	3.74	3.07	0.82	1074
30	22	4.34	3.03	0.70	983	4.18	2.93	0.70	1045	4.08	2.86	0.70	1074	3.91	2.74	0.70	1119
30	24	4.56	2.64	0.58	1028	4.39	2.54	0.58	1085	4.28	2.48	0.58	1119	4.15	2.41	0.58	1175
30	26	4.69	2.16	0.46	1085	4.56	2.10	0.46	1141	4.49	2.06	0.46	1175	4.35	2.00	0.46	1209
31	18	4.00	3.92	0.98	904	3.83	3.75	0.98	949	3.67	3.60	0.98	994	3.54	3.47	0.98	1040
31	20	4.17	3.58	0.86	949	4.00	3.44	0.86	1006	3.88	3.33	0.86	1028	3.74	3.22	0.86	1074
31	22	4.34	3.21	0.74	983	4.18	3.09	0.74	1045	4.08	3.02	0.74	1074	3.91	2.89	0.74	1119
31	24	4.56	2.82	0.62	1028	4.39	2.72	0.62	1085	4.28	2.66	0.62	1119	4.15	2.57	0.62	1175
31	26	4.69	2.35	0.50	1085	4.56	2.28	0.50	1141	4.49	2.24	0.50	1175	4.35	2.18	0.50	1209
32	18	4.00	4.00	1.00	904	3.83	3.83	1.00	949	3.67	3.67	1.00	994	3.54	3.54	1.00	1040
32	20	4.17	3.75	0.90	949	4.00	3.60	0.90	1006	3.88	3.49	0.90	1028	3.74	3.37	0.90	1074
32	22	4.34	3.38	0.78	983	4.18	3.26	0.78	1045	4.08	3.18	0.78	1074	3.91	3.05	0.78	1119
32	24	4.56	3.01	0.66	1028	4.39	2.89	0.66	1085	4.28	2.83	0.66	1119	4.15	2.74	0.66	1175
32	26	4.69	2.53	0.54	1085	4.56	2.46	0.54	1141	4.49	2.42	0.54	1175	4.35	2.35	0.54	1209

**NOTE** Q : Total capacity (kW) SHF : Sensible heat factor DB : Dry-bulb temperature  
 SHC : Sensible heat capacity (kW) INPUT : Total power input (W) WB : Wet-bulb temperature

**PERFORMANCE DATA COOL operation at Rated frequency**

**MUZ-HC35VAB**

CAPACITY: 3.4 kW

SHF: 0.76

INPUT: 1130 W

INDOOR DB (°C)	INDOOR WB (°C)	OUTDOOR DB (°C)											
		35				40				46			
		Q	SHC	SHF	INPUT	Q	SHC	SHF	INPUT	Q	SHC	SHF	INPUT
21	18	3.33	1.93	0.58	1107	3.06	1.77	0.58	1175	2.82	1.64	0.58	1220
21	20	3.50	1.61	0.46	1153	3.26	1.50	0.46	1209	3.03	1.39	0.46	1277
22	18	3.33	2.07	0.62	1107	3.06	1.90	0.62	1175	2.82	1.75	0.62	1220
22	20	3.50	1.75	0.50	1153	3.26	1.63	0.50	1209	3.03	1.51	0.50	1277
22	22	3.71	1.41	0.38	1198	3.47	1.32	0.38	1266	3.23	1.23	0.38	1311
23	18	3.33	2.20	0.66	1107	3.06	2.02	0.66	1175	2.82	1.86	0.66	1220
23	20	3.50	1.89	0.54	1153	3.26	1.76	0.54	1209	3.03	1.63	0.54	1277
23	22	3.71	1.56	0.42	1198	3.47	1.46	0.42	1266	3.23	1.36	0.42	1311
24	18	3.33	2.33	0.70	1107	3.06	2.14	0.70	1175	2.82	1.98	0.70	1220
24	20	3.50	2.03	0.58	1153	3.26	1.89	0.58	1209	3.03	1.76	0.58	1277
24	22	3.71	1.70	0.46	1198	3.47	1.60	0.46	1266	3.23	1.49	0.46	1311
24	24	3.91	1.33	0.34	1243	3.67	1.25	0.34	1300	3.47	1.18	0.34	1356
25	18	3.33	2.47	0.74	1107	3.06	2.26	0.74	1175	2.82	2.09	0.74	1220
25	20	3.50	2.17	0.62	1153	3.26	2.02	0.62	1209	3.03	1.88	0.62	1277
25	22	3.71	1.85	0.50	1198	3.47	1.73	0.50	1266	3.23	1.62	0.50	1311
25	24	3.91	1.49	0.38	1243	3.67	1.40	0.38	1300	3.47	1.32	0.38	1356
26	18	3.33	2.60	0.78	1107	3.06	2.39	0.78	1175	2.82	2.20	0.78	1220
26	20	3.50	2.31	0.66	1153	3.26	2.15	0.66	1209	3.03	2.00	0.66	1277
26	22	3.71	2.00	0.54	1198	3.47	1.87	0.54	1266	3.23	1.74	0.54	1311
26	24	3.91	1.64	0.42	1243	3.67	1.54	0.42	1300	3.47	1.46	0.42	1356
26	26	4.11	1.23	0.30	1288	3.88	1.16	0.30	1345	3.64	1.09	0.30	1401
27	18	3.33	2.73	0.82	1107	3.06	2.51	0.82	1175	2.82	2.31	0.82	1220
27	20	3.50	2.45	0.70	1153	3.26	2.28	0.70	1209	3.03	2.12	0.70	1277
27	22	3.71	2.15	0.58	1198	3.47	2.01	0.58	1266	3.23	1.87	0.58	1311
27	24	3.91	1.80	0.46	1243	3.67	1.69	0.46	1300	3.47	1.60	0.46	1356
27	26	4.11	1.40	0.34	1288	3.88	1.32	0.34	1345	3.64	1.24	0.34	1401
28	18	3.33	2.87	0.86	1107	3.06	2.63	0.86	1175	2.82	2.43	0.86	1220
28	20	3.50	2.59	0.74	1153	3.26	2.42	0.74	1209	3.03	2.24	0.74	1277
28	22	3.71	2.30	0.62	1198	3.47	2.15	0.62	1266	3.23	2.00	0.62	1311
28	24	3.91	1.96	0.50	1243	3.67	1.84	0.50	1300	3.47	1.73	0.50	1356
28	26	4.11	1.56	0.38	1288	3.88	1.47	0.38	1345	3.64	1.38	0.38	1401
29	18	3.33	3.00	0.90	1107	3.06	2.75	0.90	1175	2.82	2.54	0.90	1220
29	20	3.50	2.73	0.78	1153	3.26	2.55	0.78	1209	3.03	2.36	0.78	1277
29	22	3.71	2.45	0.66	1198	3.47	2.29	0.66	1266	3.23	2.13	0.66	1311
29	24	3.91	2.11	0.54	1243	3.67	1.98	0.54	1300	3.47	1.87	0.54	1356
29	26	4.11	1.73	0.42	1288	3.88	1.63	0.42	1345	3.64	1.53	0.42	1401
30	18	3.33	3.13	0.94	1107	3.06	2.88	0.94	1175	2.82	2.65	0.94	1220
30	20	3.50	2.87	0.82	1153	3.26	2.68	0.82	1209	3.03	2.48	0.82	1277
30	22	3.71	2.59	0.70	1198	3.47	2.43	0.70	1266	3.23	2.26	0.70	1311
30	24	3.91	2.27	0.58	1243	3.67	2.13	0.58	1300	3.47	2.01	0.58	1356
30	26	4.11	1.89	0.46	1288	3.88	1.78	0.46	1345	3.64	1.67	0.46	1401
31	18	3.33	3.27	0.98	1107	3.06	3.00	0.98	1175	2.82	2.77	0.98	1220
31	20	3.50	3.01	0.86	1153	3.26	2.81	0.86	1209	3.03	2.60	0.86	1277
31	22	3.71	2.74	0.74	1198	3.47	2.57	0.74	1266	3.23	2.39	0.74	1311
31	24	3.91	2.42	0.62	1243	3.67	2.28	0.62	1300	3.47	2.15	0.62	1356
31	26	4.11	2.06	0.50	1288	3.88	1.94	0.50	1345	3.64	1.82	0.50	1401
32	18	3.33	3.33	1.00	1107	3.06	3.06	1.00	1175	2.82	2.82	1.00	1220
32	20	3.50	3.15	0.90	1153	3.26	2.94	0.90	1209	3.03	2.72	0.90	1277
32	22	3.71	2.89	0.78	1198	3.47	2.71	0.78	1266	3.23	2.52	0.78	1311
32	24	3.91	2.58	0.66	1243	3.67	2.42	0.66	1300	3.47	2.29	0.66	1356
32	26	4.11	2.22	0.54	1288	3.88	2.09	0.54	1345	3.64	1.96	0.54	1401

**NOTE** Q : Total capacity (kW) SHF : Sensible heat factor DB : Dry-bulb temperature  
 SHC : Sensible heat capacity (kW) INPUT : Total power input (W) WB : Wet-bulb temperature

**PERFORMANCE DATA HEAT operation at Rated frequency  
MUZ-HC25VA**

CAPACITY: 3.2 kW INPUT: 880 W

INDOOR DB (°C)	OUTDOOR WB (°C)													
	-10		-5		0		5		10		15		20	
	Q	INPUT	Q	INPUT	Q	INPUT	Q	INPUT	Q	INPUT	Q	INPUT	Q	INPUT
15	2.02	572	2.43	686	2.85	774	3.26	836	3.68	889	4.06	915	4.48	933
21	1.92	616	2.30	730	2.72	810	3.10	871	3.52	915	3.90	942	4.30	977
26	1.73	660	2.14	774	2.53	854	2.94	915	3.36	959	3.74	986	4.16	1012

**MUZ-HC35VA MUZ-HC35VAB**

CAPACITY: 3.6 kW INPUT: 995 W

INDOOR DB (°C)	OUTDOOR WB (°C)													
	-10		-5		0		5		10		15		20	
	Q	INPUT	Q	INPUT	Q	INPUT	Q	INPUT	Q	INPUT	Q	INPUT	Q	INPUT
15	2.27	647	2.74	776	3.20	876	3.67	945	4.14	1005	4.57	1035	5.04	1055
21	2.16	697	2.59	826	3.06	915	3.49	985	3.96	1035	4.39	1065	4.84	1104
26	1.94	746	2.41	876	2.84	965	3.31	1035	3.78	1085	4.21	1114	4.68	1144

**NOTE** Q: Total capacity (kW) INPUT : Total power input (W) DB: Dry-bulb temperature WB: Wet-bulb temperature

**MUZ-HC25VA MUZ-HC35VA MUZ-HC35VAB**

**9-1. OUTDOOR FAN MOTOR CONTROL**

The fan motor turns ON/OFF, interlocking with the compressor.

[ON] The fan motor turns ON 5 seconds before the compressor starts up.

[OFF] The fan motor turns OFF 15 seconds after the compressor has stopped running.

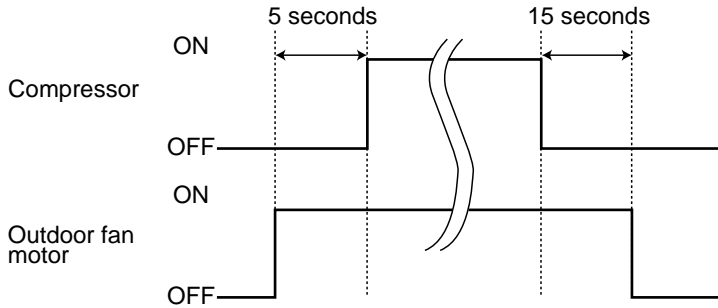

**9-2. R.V. COIL CONTROL**

Heating . . . . . ON

Cooling . . . . . OFF

Dry . . . . . OFF

**NOTE:** The 4-way valve reverses for 5 seconds right before start-up of the compressor.

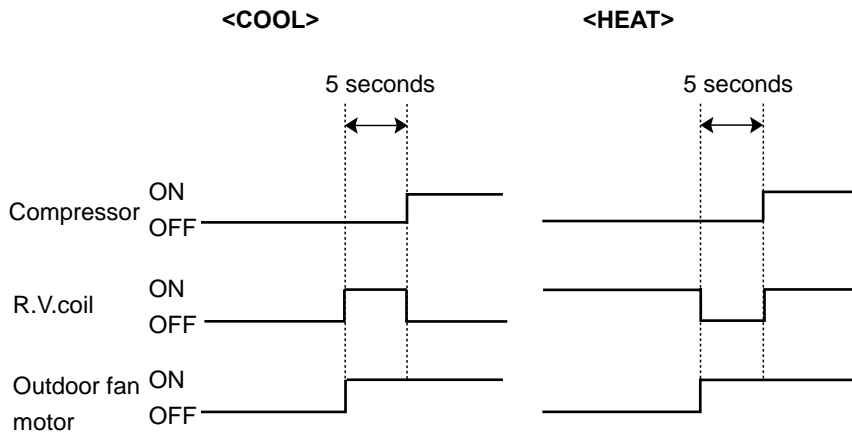

**9-3. RELATION BETWEEN MAIN SENSOR AND ACTUATOR**

Sensor	Purpose	Actuator				
		Compressor	LEV *	Outdoor fan motor	R.V. coil	Indoor fan motor
Discharge temperature thermistor	Protection	○	○			
Indoor coil temperature thermistor	Cooling: Coil frost prevention	○				
	Heating: High pressure protection	○				
Defrost thermistor	Cooling: High pressure protection	○	○	○		
	Heating: Defrosting	○	○	○	○	○
Fin temperature thermistor	Protection	○		○		

\* HC35VA- [E2], HC35VAB- [E2]



# 10

# SERVICE FUNCTIONS

## MUZ-HC25VA MUZ-HC35VA MUZ-HC35VAB

### 10-1. CHANGE IN DEFROST SETTING

<JS> When the JS wire of the inverter P.C. board is cut/ soldered, the defrost finish temperature is changed. (Refer to 11-6-1.)

Jumper wire		Defrost finish temperature (°C)
JS	Soldered (Initial setting)	5
	None (Cut)	8

### 10-2. PRE-HEAT CONTROL SETTING

#### PRE-HEAT CONTROL

When moisture gets into the refrigerant cycle, it may interfere the start-up of the compressor at low outside temperature. The pre-heat control prevents this interference. The pre-heat control turns ON when outside temperature is 20°C or below. When pre-heat control is turned ON, compressor is energized. (About 50 W)

<JK> When the JK wire of the inverter P.C. board is cut, pre-heat control is activated. (Refer to 11-6.1)

**NOTE :** When the inverter P.C. board is replaced, check the Jumper wires, and cut/solder them if necessary.

# 11

# SERVICE FUNCTIONS

## MUZ-HC25VA MUZ-HC35VA MUZ-HC35VAB

### 11-1. CAUTIONS ON TROUBLESHOOTING

#### 1. Before troubleshooting, check the following:

- 1) Check the power supply voltage.
- 2) Check the indoor/outdoor connecting wire for miswiring.

#### 2. Take care of the following during servicing

- 1) Before servicing the air conditioner, be sure to turn OFF the main unit first with the remote controller, and then after confirming the horizontal vane is closed, turn OFF the breaker and/or disconnect the power plug.
- 2) Be sure to turn OFF the power supply before removing the front panel, the cabinet, the top panel, and the electronic control P.C. board.
- 3) When removing the electrical parts, be careful to the residual voltage of smoothing capacitor.
- 4) When removing the electronic control P.C. board, hold the edge of the board with care NOT to apply stress on the components.
- 5) When connecting or disconnecting the connectors, hold the housing of the connector. DO NOT pull the lead wires.

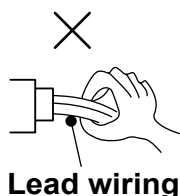

Lead wiring

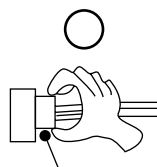

Housing point

#### 3. Troubleshooting procedure

- 1) First, check if the OPERATION INDICATOR lamp on the indoor unit is flashing on and off to indicate an abnormality. To make sure, check how many times the abnormality indication is flashing on and off before starting service work.
- 2) Before servicing check that the connector and terminal are connected properly.
- 3) If the electronic control P.C. board is supposed to be defective, check the copper foil pattern for disconnection and the components for bursting and discoloration.
- 4) Refer to 11-2. and 11-3.

## 11-2. FAILURE MODE RECALL FUNCTION

Outline of the function

This air conditioner can memorize the abnormal condition which has occurred once.

Even though LED indication listed on the troubleshooting check table (11-3.) disappears, the memorized failure details can be recalled.

This mode is very useful when the unit needs to be repaired for the abnormality which doesn't recur.

### 1. Flow chart of failure mode recall function for the indoor/outdoor unit

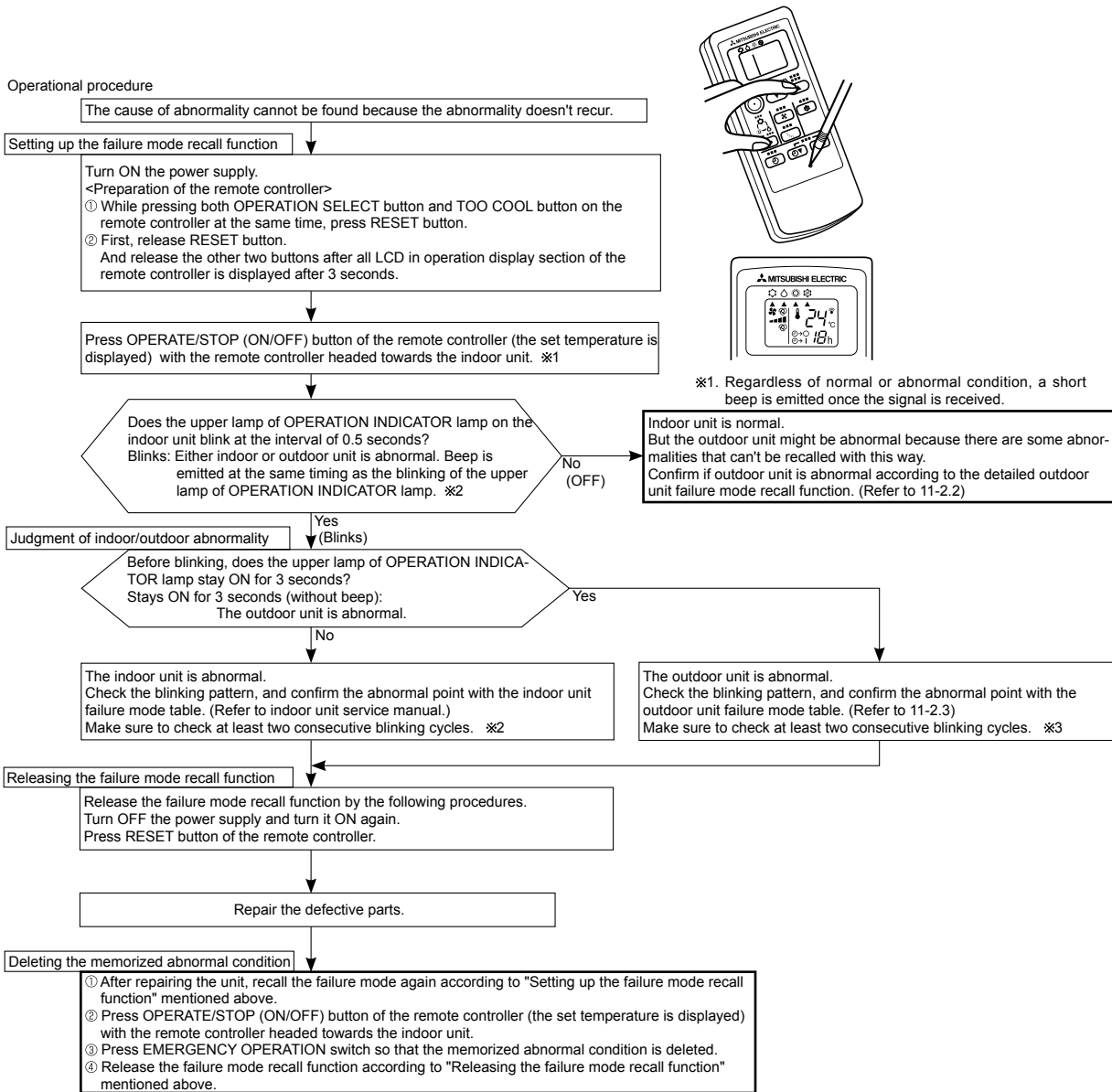

**NOTE:** 1. Make sure to release the failure mode recall function once it's set up, otherwise the unit cannot operate properly.  
2. If the abnormal condition is not deleted from the memory, the last abnormal condition is kept memorized.

※2. Blinking pattern when the indoor unit is abnormal:

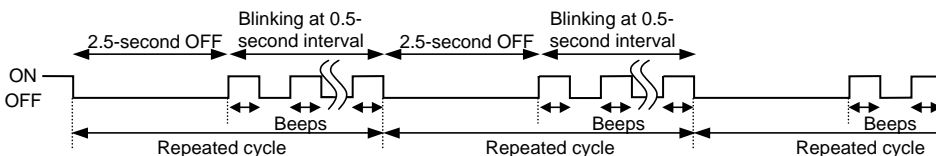

※3. Blinking pattern when the outdoor unit is abnormal:

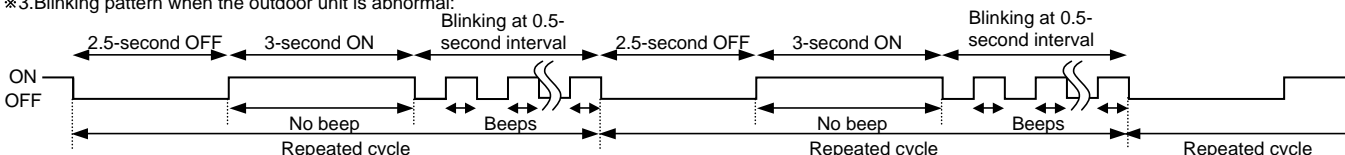

## 2. Flow chart of the detailed outdoor unit failure mode recall function

### Operational procedure

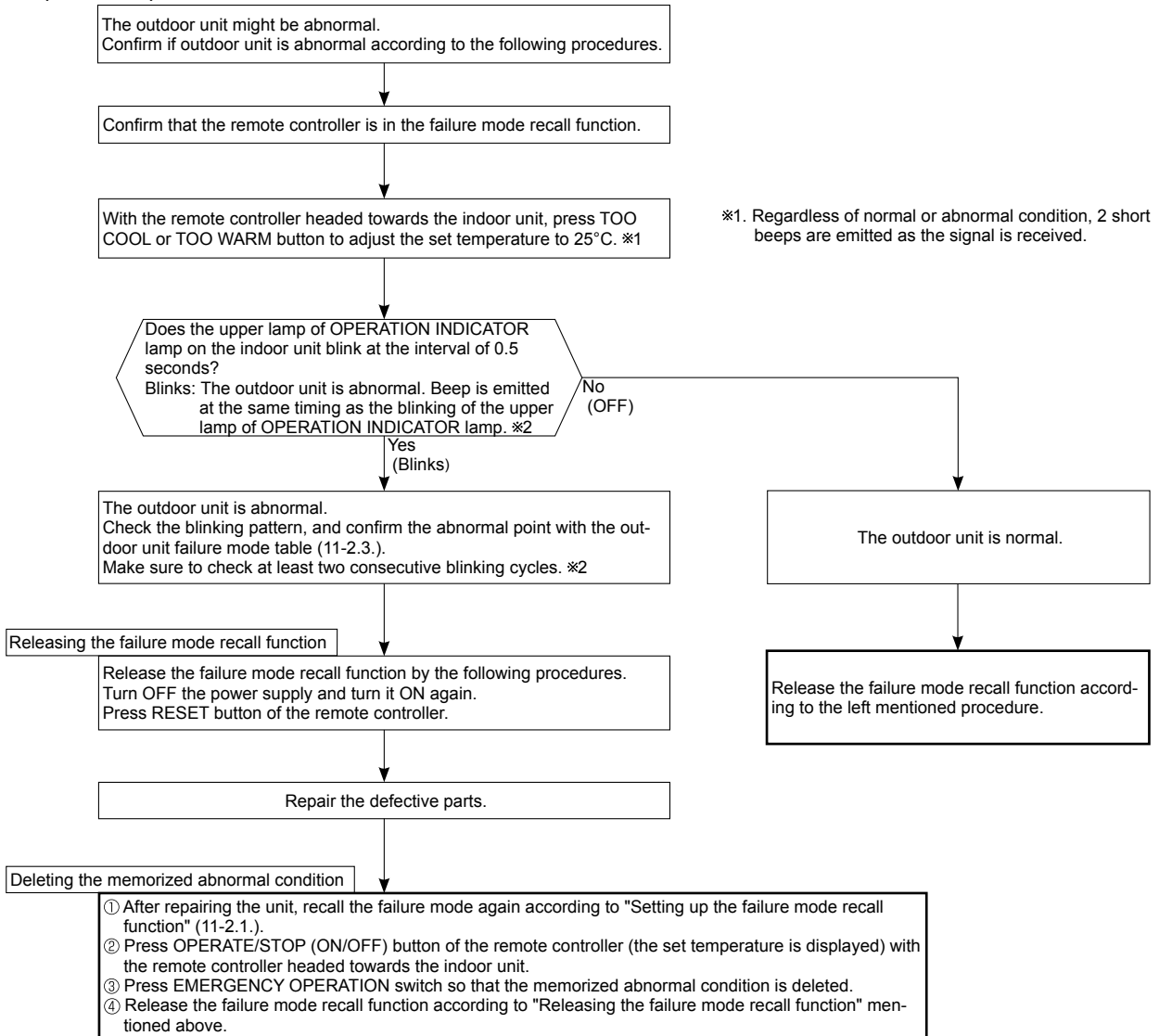

**NOTE:** 1. Make sure to release the failure mode recall function once it's set up, otherwise the unit cannot operate properly.  
2. If the abnormal condition is not deleted from the memory, the last abnormal condition is kept memorized.

\*2. Blinking pattern when outdoor unit is abnormal:

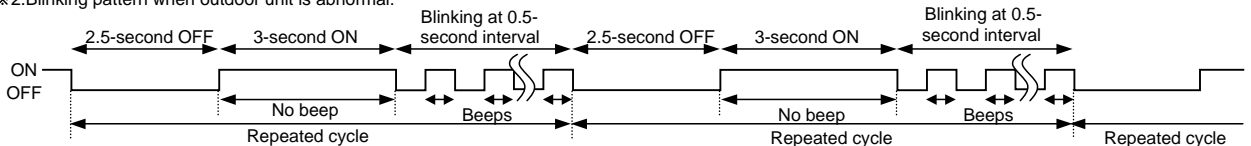

### 3. Outdoor unit failure mode table

The upper lamp of OPERATION INDICATOR lamp (Indoor unit)	Abnormal point (Failure mode / protection)	LED indication (Outdoor P.C. board)	Condition	Correspondence	Indoor/outdoor unit failure mode recall function	Outdoor unit failure mode recall function
OFF	None (Normal)	—	—	—	—	—
2-time flash 2.5 seconds OFF	Outdoor power system	—	Over current protection stop is continuously performed 3 times within 1 minute after the compressor gets started.	<ul style="list-style-type: none"> <li>• Reconnect connectors.</li> <li>• Refer to 11-5. Ⓐ "How to check inverter/compressor".</li> <li>• Check stop valve.</li> </ul>	○	○
3-time flash 2.5 seconds OFF	Discharge temperature thermistor	1-time flash every 2.5 seconds	Thermistor shorts or opens during compressor running.	<ul style="list-style-type: none"> <li>• Refer to 11-5. Ⓒ "Check of outdoor thermistors".</li> <li>• Defective outdoor thermistors can be identified by checking the blinking pattern of LED.</li> </ul>	○	○
	Defrost thermistor	3-time flash 2.5 seconds OFF				
	Fin temperature thermistor	4-time flash 2.5 seconds OFF				
4-time flash 2.5 seconds OFF	Overcurrent	11-time flash 2.5 seconds OFF	12 A (HC25) / 14 A (HC35) current flow into intelligent power module.	<ul style="list-style-type: none"> <li>• Reconnect compressor connector.</li> <li>• Refer to 11-5. Ⓐ "How to check inverter/compressor".</li> <li>• Check stop valve.</li> </ul>	—	○
	Compressor synchronous abnormality (Compressor start-up failure protection)	12-time flash 2.5 seconds OFF	Waveform of compressor current is distorted.	<ul style="list-style-type: none"> <li>• Reconnect compressor connector.</li> <li>• Refer to 11-5. Ⓐ "How to check inverter/compressor".</li> </ul>	—	○
5-time flash 2.5 seconds OFF	Discharge temperature	—	Temperature of discharge temperature thermistor exceeds 116°C, compressor stops. Compressor can restart if discharge temperature thermistor reads 100°C or less 3 minutes later.	<ul style="list-style-type: none"> <li>• Check refrigerant circuit and refrigerant amount.</li> <li>• Refer to 11-5. Ⓒ "Check of LEV".</li> </ul>	—	○
6-time flash 2.5 seconds OFF	High pressure	—	Temperature of indoor coil thermistor exceeds 70°C in HEAT mode. When defrost thermistor exceeds 70°C in COOL mode.	<ul style="list-style-type: none"> <li>• Check refrigerant circuit and refrigerant amount.</li> <li>• Check stop valve.</li> </ul>	—	○
7-time flash 2.5 seconds OFF	Fin temperature/ P.C. board temperature	7-time flash 2.5 seconds OFF	Temperature of fin temperature thermistor on the inverter P.C. board exceeds 82°C (HC25) / 83°C (HC35), or temperature of P.C. board temperature thermistor on the inverter P.C. board exceeds 81°C (HC25) / 85°C (HC35).	<ul style="list-style-type: none"> <li>• Check around outdoor unit.</li> <li>• Check outdoor unit air passage.</li> <li>• Refer to 11-5. Ⓒ "Check of outdoor fan motor".</li> </ul>	—	○
9-time flash 2.5 seconds OFF	Nonvolatile memory data	5-time flash 2.5 seconds OFF	Nonvolatile memory data cannot be read properly.	<ul style="list-style-type: none"> <li>• Replace the inverter P.C. board.</li> </ul>	○	○
10-time flash 2.5 seconds OFF	Discharge temperature	—	Temperature of discharge temperature thermistor has been 50°C or less for 20 minutes.	<ul style="list-style-type: none"> <li>• Refer to 11-5. Ⓒ "Check of LEV".</li> <li>• Check refrigerant circuit and refrigerant amount.</li> </ul>	—	○
11-time flash 2.5 seconds OFF	DC voltage	8-time flash 2.5 seconds OFF	DC voltage of inverter cannot be detected normally.	<ul style="list-style-type: none"> <li>• Refer to 11-5. Ⓐ "How to check inverter/compressor".</li> </ul>	—	○
	Each phase current of compressor	9-time flash 2.5 seconds OFF	Each phase current of compressor cannot be detected normally.			
12-time flash 2.5 seconds OFF	Overcurrent Compressor open-phase	10-time flash 2.5 seconds OFF	12 A (HC25) / 14 A (HC35) current flow into intelligent power module (IPM). When the open-phase operation of compressor is detected. When the interphase short out occurs in the output of the intelligent power module (IPM). When the compressor winding shorts out.	<ul style="list-style-type: none"> <li>• Reconnect compressor connector.</li> <li>• Refer to 11-5. Ⓐ "How to check inverter/compressor".</li> </ul>	—	○
14-time flash 2.5 seconds OFF	Stop valve (Closed valve)	14-time flash 2.5 seconds OFF	Closed valve is detected by compressor current.	<ul style="list-style-type: none"> <li>• Check stop valve.</li> </ul>	○	○

**NOTE:** Blinking patterns of this mode differ from the ones of Troubleshooting check table (11-3.).

### 11-3. TROUBLESHOOTING CHECK TABLE

No.	Symptom	LED indication	Abnormal point / Condition	Condition	Correspondence
1	Outdoor unit does not operate.	1-time flash every 2.5 seconds	Outdoor power system	Over current protection stop is continuously performed 3 times within 1 minute after the compressor gets started, or failure of restart of compressor has repeated 24 times.	<ul style="list-style-type: none"> <li>Reconnect connector of compressor.</li> <li>Refer to 11-5.Ⓐ "How to check inverter/compressor".</li> <li>Check stop valve.</li> </ul>
2			Outdoor thermistors	Discharge temperature thermistor, fin temperature thermistor, defrost thermistor, P.C. board temperature thermistor shorts or opens during compressor running.	<ul style="list-style-type: none"> <li>Refer to 11-5.Ⓒ "Check of outdoor thermistors".</li> </ul>
3			Outdoor control system	Nonvolatile memory data cannot be read properly. (The upper lamp of OPERATION INDICATOR lamp of the indoor unit lights up or flashes 7-time.)	<ul style="list-style-type: none"> <li>Replace inverter P.C. board.</li> </ul>
4			Serial signal	The communication fails between the indoor and outdoor unit for 3 minutes.	<ul style="list-style-type: none"> <li>Refer to 11-5.Ⓔ "How to check miswiring and serial signal error."</li> </ul>
5			Stop valve / Closed valve	Closed valve is detected by compressor current.	<ul style="list-style-type: none"> <li>Check stop valve.</li> </ul>
6			Outdoor unit (Other abnormality)	Outdoor unit is defective.	<ul style="list-style-type: none"> <li>Refer to 11-2.2. "Flow chart of the detailed outdoor unit failure mode recall function".</li> </ul>
7	Outdoor unit stops and restarts 3 minutes later is repeated.	2-time flash 2.5 seconds OFF	Overcurrent protection	12 A (HC25) / 14 A (HC35) current flows into intelligent power module. ※When overcurrent protection occurs within 10 seconds after compressor starts, compressor restarts after 15 seconds.	<ul style="list-style-type: none"> <li>Reconnect connector of compressor.</li> <li>Refer to 11-5.Ⓐ "How to check inverter/compressor".</li> <li>Check stop valve.</li> </ul>
8			Discharge temperature overheat protection	Temperature of discharge temperature thermistor exceeds 116°C, compressor stops. Compressor can restart if discharge temperature thermistor reads 100°C or less 3 minutes later.	<ul style="list-style-type: none"> <li>Check refrigerant circuit and refrigerant amount.</li> <li>Refer to 11-5.Ⓞ "Check of LEV".</li> </ul>
9			Fin temperature / P.C. board temperature thermistor overheat protection	Temperature of fin temperature thermistor on the heat sink exceeds 82°C (HC25) / 83°C (HC35) or temperature of P.C. board temperature thermistor on the inverter P.C. board exceeds 81°C (HC25) / 85°C (HC35).	<ul style="list-style-type: none"> <li>Check around outdoor unit.</li> <li>Check outdoor unit air passage.</li> <li>Refer to 11-5.Ⓟ "Check of outdoor fan motor".</li> </ul>
10			High pressure protection	Indoor coil thermistor exceeds 70°C in HEAT mode. When the defrost thermistor exceeds 70°C in COOL mode.	<ul style="list-style-type: none"> <li>Check refrigerant circuit and refrigerant amount.</li> <li>Check stop valve.</li> </ul>
11			Compressor synchronous abnormality	The waveform of compressor current is distorted.	<ul style="list-style-type: none"> <li>Reconnect connector of compressor.</li> <li>Refer to 11-5.Ⓐ "How to check inverter/compressor".</li> </ul>
12			Each phase current of compressor	Each phase current of compressor cannot be detected normally	<ul style="list-style-type: none"> <li>Refer to 11-5.Ⓐ "How to check inverter/compressor".</li> </ul>
13			DC voltage	DC voltage of inverter cannot be detected normally.	
14			Outdoor unit operates.	1-time flash 2.5 seconds OFF	Frequency drop by current protection
15	Frequency drop by high pressure protection	Temperature of indoor coil thermistor exceeds 55°C in HEAT mode, compressor frequency lowers.			
15	Frequency drop by defrosting in COOL mode	Indoor coil thermistor reads 8°C or less in COOL mode, compressor frequency lowers.			
16	Frequency drop by discharge temperature protection	Temperature of discharge temperature thermistor exceeds 111°C, compressor frequency lowers.			
17	Outdoor unit operates.	7-time flash 2.5 seconds OFF	Low discharge temperature protection	Temperature of discharge temperature thermistor has been 50°C or less for 20 minutes.	<ul style="list-style-type: none"> <li>Refer to 11-5.Ⓞ "Check of LEV".</li> <li>Check refrigerant circuit and refrigerant amount.</li> </ul>
18			PAM protection PAM: Pulse Amplitude Modulation	The overcurrent flows into IGBT (Insulated Gate Bipolar transistor: TR821) or when the bus-bar voltage reaches 320 V or more, PAM stops and restarts.	<ul style="list-style-type: none"> <li>This is not malfunction.</li> <li>PAM protection will be activated in the following cases;</li> <li>1 Instantaneous power voltage drop (Short time power failure)</li> <li>2 When the power supply voltage is high.</li> </ul>
19			Inverter check mode	The connector of compressor is disconnected, inverter check mode starts.	<ul style="list-style-type: none"> <li>Check if the connector of the compressor is correctly connected.</li> <li>Refer to 11-5.Ⓐ "How to check inverter/compressor".</li> </ul>

NOTE : 1. The location of LED is illustrated at the right figure. Refer to 11-6.1.  
2. LED is lighted during normal operation.

Inverter P.C. board (Parts side)

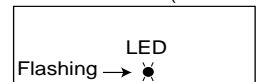

The flashing frequency shows the number of times the LED blinks after every 2.5-second OFF.  
(Example) When the flashing frequency is "2".

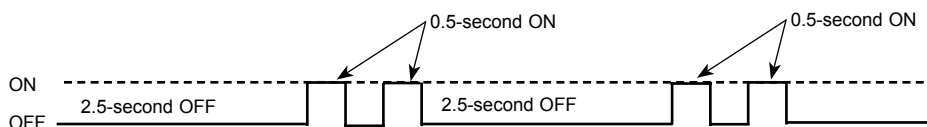

**11-4. TROUBLE CRITERION OF MAIN PARTS**  
**MUZ-HC25VA MUZ-HC35VA MUZ-HC35VAB**

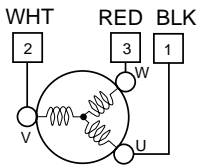
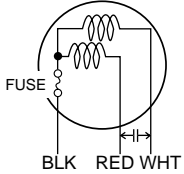
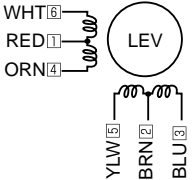
Part name	Check method and criterion	Figure											
Defrost thermistor (RT61)	Measure the resistance with a tester. Refer to 11-6. "Test point diagram and voltage", 1. "Inverter P.C. board", the chart of thermistor.	/											
Discharge temperature thermistor (RT62) Fin temperature thermistor (RT64)	Measure the resistance with a tester. Before measurement, hold the thermistor with your hands to warm it up. Refer to 11-6. "Test point diagram and voltage", 1. "Inverter P.C. board", the chart of thermistor.	/											
Compressor (MC)	Measure the resistance between the terminals with a tester. (Part temperature -10 – 40°C) <table border="1" data-bbox="395 725 839 869" style="margin: 10px auto;"> <thead> <tr> <th colspan="3" style="text-align: center;">Normal</th> </tr> <tr> <th style="text-align: center;">U-V</th> <th style="text-align: center;">MUZ-HC25</th> <th style="text-align: center;">MUZ-HC35</th> </tr> </thead> <tbody> <tr> <td style="text-align: center;">U-W</td> <td rowspan="2" style="text-align: center;">1.65 – 2.03 Ω</td> <td rowspan="2" style="text-align: center;">1.49 – 1.84 Ω</td> </tr> <tr> <td style="text-align: center;">V-W</td> </tr> </tbody> </table>	Normal			U-V	MUZ-HC25	MUZ-HC35	U-W	1.65 – 2.03 Ω	1.49 – 1.84 Ω	V-W		
Normal													
U-V	MUZ-HC25	MUZ-HC35											
U-W	1.65 – 2.03 Ω	1.49 – 1.84 Ω											
V-W													
Outdoor fan motor (MF) INNER FUSE RA6V21-AB 152 <sup>+0</sup> / <sub>-5</sub> °C CUT OFF RA6V21-BB 126 ± 2: CUT OFF	Measure the resistance between the terminals with a tester. (Part temperature -10 – 40°C) <table border="1" data-bbox="395 934 1107 1061" style="margin: 10px auto;"> <thead> <tr> <th rowspan="2" style="text-align: center;">Color of lead wire</th> <th colspan="2" style="text-align: center;">Normal</th> </tr> <tr> <th style="text-align: center;">RA6V21-AB</th> <th style="text-align: center;">RA6V21-BB, BD</th> </tr> </thead> <tbody> <tr> <td style="text-align: center;">WHT – BLK</td> <td style="text-align: center;">305 – 374 Ω</td> <td style="text-align: center;">222 – 272 Ω</td> </tr> <tr> <td style="text-align: center;">BLK – RED</td> <td style="text-align: center;">247 – 304 Ω</td> <td style="text-align: center;">245 – 300 Ω</td> </tr> </tbody> </table>	Color of lead wire	Normal		RA6V21-AB	RA6V21-BB, BD	WHT – BLK	305 – 374 Ω	222 – 272 Ω	BLK – RED	247 – 304 Ω	245 – 300 Ω	
Color of lead wire	Normal												
	RA6V21-AB	RA6V21-BB, BD											
WHT – BLK	305 – 374 Ω	222 – 272 Ω											
BLK – RED	247 – 304 Ω	245 – 300 Ω											
R.V. coil (21S4)	Measure the resistance between the terminals with a tester. (Part temperature -10°C – 40°C) <table border="1" data-bbox="395 1144 668 1227" style="margin: 10px auto;"> <thead> <tr> <th style="text-align: center;">Normal</th> </tr> </thead> <tbody> <tr> <td style="text-align: center;">1.32 – 1.62 kΩ</td> </tr> </tbody> </table>	Normal	1.32 – 1.62 kΩ	/									
Normal													
1.32 – 1.62 kΩ													
Expansion valve coil (LEV) HC35VA- E2 HC35VAB- E2	Measure the resistance using a tester. (Part temperature: -10 – 40°C) <table border="1" data-bbox="395 1308 895 1469" style="margin: 10px auto;"> <thead> <tr> <th style="text-align: center;">Color of lead wire</th> <th style="text-align: center;">Normal</th> </tr> </thead> <tbody> <tr> <td style="text-align: center;">WHT – RED</td> <td rowspan="4" style="text-align: center;">38 – 50 Ω</td> </tr> <tr> <td style="text-align: center;">RED – ORN</td> </tr> <tr> <td style="text-align: center;">YLW – BRN</td> </tr> <tr> <td style="text-align: center;">BRN – BLU</td> </tr> </tbody> </table>	Color of lead wire	Normal	WHT – RED	38 – 50 Ω	RED – ORN	YLW – BRN	BRN – BLU					
Color of lead wire	Normal												
WHT – RED	38 – 50 Ω												
RED – ORN													
YLW – BRN													
BRN – BLU													

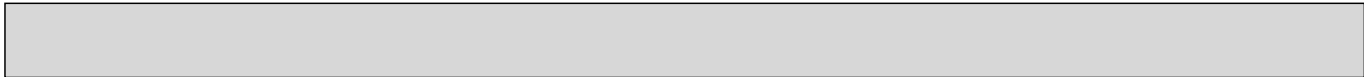

### 11-5. TROUBLESHOOTING FLOW

#### **A** How to check inverter/compressor

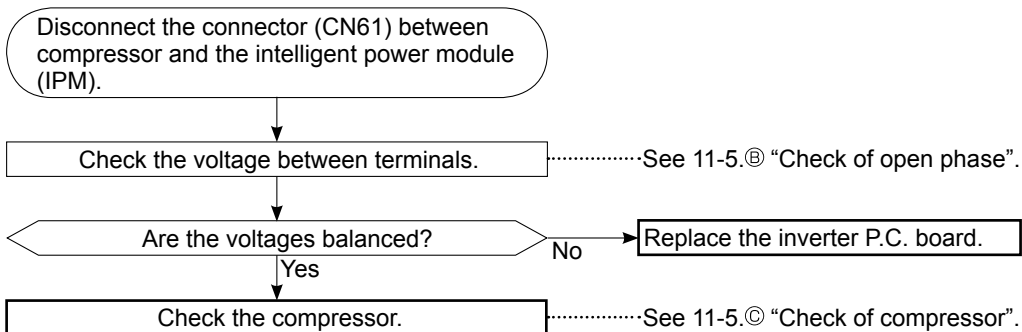

#### **B** Check of open phase

- With the connector between the compressor and the intelligent power module disconnected, activate the inverter and check if the inverter is normal by measuring **the balance of voltage** between the terminals.

Output voltage is 50 - 130 V. (The voltage may differ according to the tester.)

<< Operation method >>

Start cooling or heating operation by pressing EMERGENCY OPERATION switch on the indoor unit. (TEST RUN OPERATION : Refer to 8-3.)

<< Measurement point >>

At 3 points

BLK (U)-WHT (V)

※ Measure AC voltage between the lead wires at 3 points.

BLK (U)-RED (W)

WHT(V)-RED (W)

- NOTE** :
1. Output voltage varies according to power supply voltage.
  2. Measure the voltage by analog type tester.
  3. During this check, LED of the inverter P.C. board flashes 9 times. (Refer to 11-6.1.)

### C Check of compressor

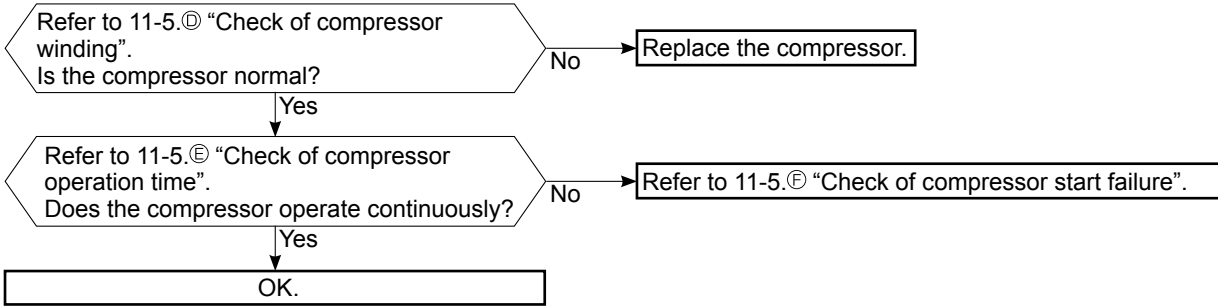

### D Check of compressor winding

- Disconnect the connector (CN61) between the compressor and intelligent power module, and measure the resistance between the compressor terminals.

<<Measurement point>>

At 3 points  
BLK-WHT  
BLK-RED  
WHT-RED

※ Measure the resistance between the lead wires at 3 points.

<<Judgement>>

Refer to 11-4.

0 [Ω] .....Abnormal [short]

Infinite [Ω] .....Abnormal [open]

**NOTE** : Be sure to zero the ohmmeter before measurement.

### E Check of compressor operation time

- Connect the compressor and activate the inverter. Then measure the time until the inverter stops due to over current.

<<Operation method>>

Start heating or cooling operation by pressing EMERGENCY OPERATION switch on the indoor unit.  
(TEST RUN OPERATION: Refer to 8-3.)

<<Measurement>>

Measure the time from the start of compressor to the stop of compressor due to overcurrent.

<<Judgement>>

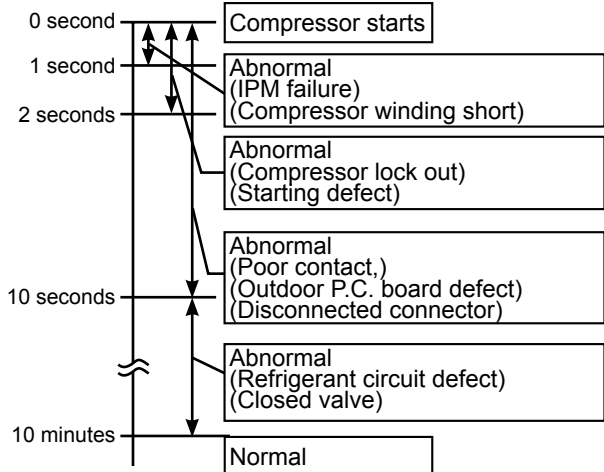



## F Check of compressor start failure

Confirm that ①~④ is normal.

•Electrical circuit check

- ①. Contact of the compressor connector (Including CN61)
- ②. Output voltage of inverter P.C. board and balance of them (See 11-5.⑥)
- ③. Direct current voltage between DB61(+) and (-) on the inverter P.C. board
- ④. Voltage between outdoor terminal block S1-S2

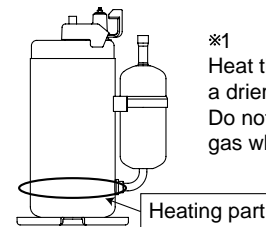
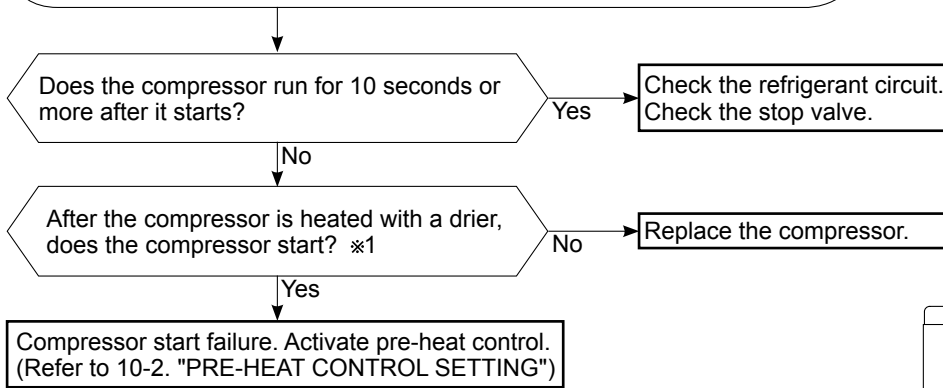

※1  
Heat the compressor with a drier for about 20 minutes. Do not recover refrigerant gas while heating.

## G Check of outdoor thermistors

Disconnect the connector of thermistor in the outdoor P.C. board (see below table), and measure the resistance of thermistor.

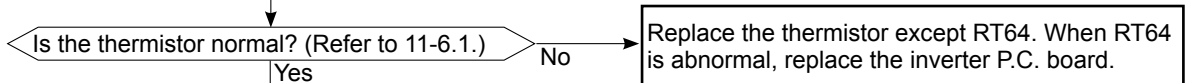

Reconnect the connector of thermistor. Turn ON the power supply and press EMERGENCY OPERATION switch.

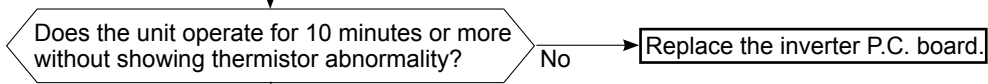

OK.  
(Cause is poor contact.)

Thermistor	Symbol	Connector, Pin No.	Board
Defrost	RT61	Between CN641 pin1 and pin2	Inverter P.C. board
Discharge temperature	RT62	Between CN641 pin3 and pin4	
Fin temperature	RT64	Between CN642 pin1 and pin2	

## H Check of R.V. coil

- ※ First of all, measure the resistance of R.V. coil to check if the coil is defective. Refer to 11-4.
- ※ In case CN721 is not connected or R.V. coil is open, voltage is generated between the terminal pins of the connector although any signal is not being transmitted to R.V. coil.  
Check if CN721 is connected.

### Unit operates COOL mode even if it is set to HEAT mode.

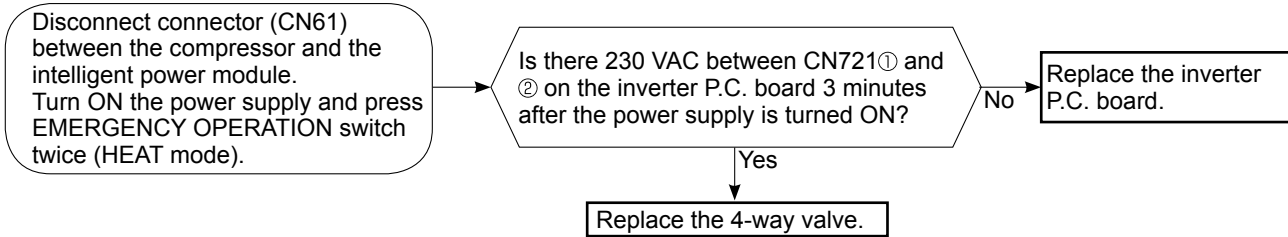

### Unit operates HEAT mode even if it is set to COOL mode.

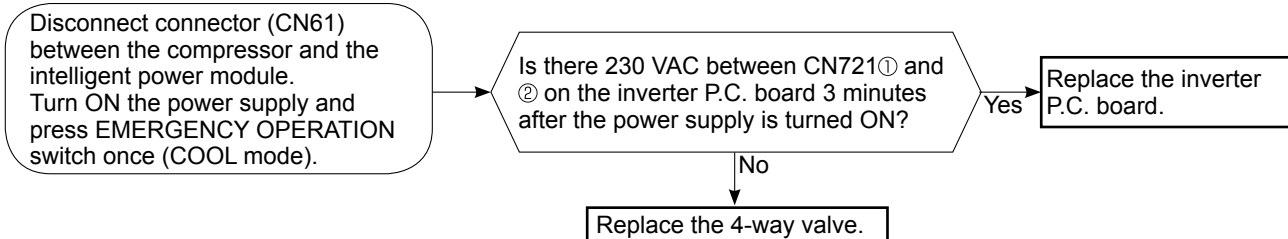

## I Check of outdoor fan motor

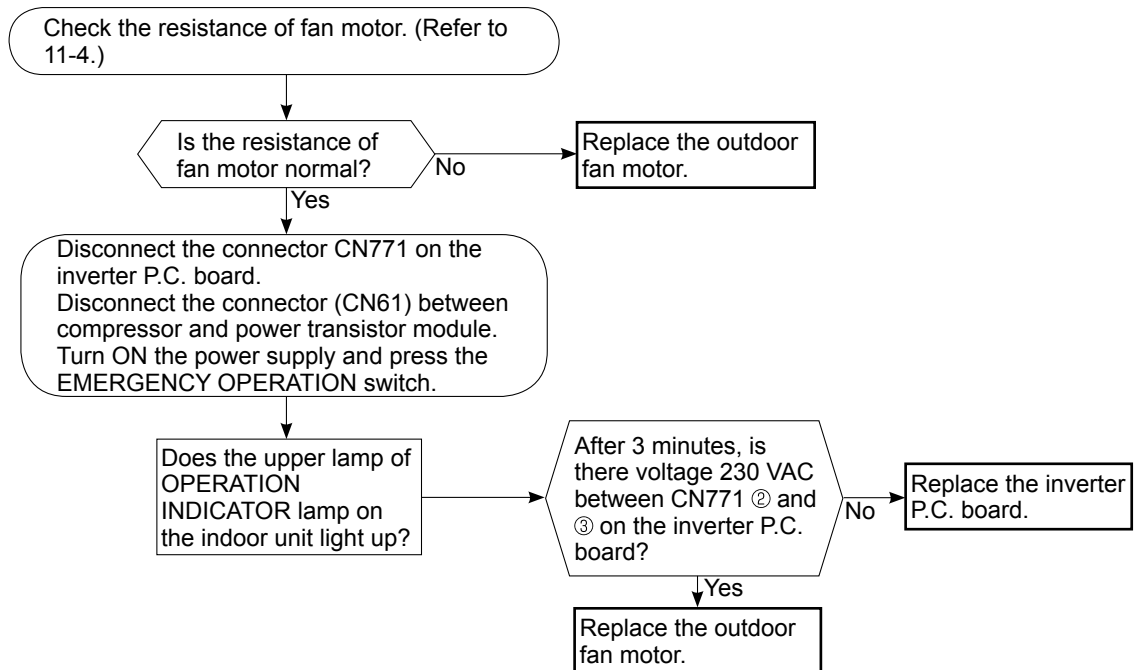

**J Check of power supply**

Disconnect the connector (CN61) between compressor and intelligent power module.  
Turn ON power supply and press EMERGENCY OPERATION switch.

Does the upper lamp of OPERATION INDICATOR lamp on the indoor unit light up?

Yes

Is there voltage 280 - 370 VDC between DB61 (+) and DB61 (-) on the inverter P.C. board? (Refer to 11-6.1.)

No

Check the electric parts in main circuit.

Rectify indoor/outdoor connecting wire.

Yes

Is there voltage 230 VAC between the indoor terminal block S1 and S2?

No

Replace the indoor electronic control P.C. board.

Does LED on the inverter P.C. board light up or flash? (Refer to 11-6.1.)

No

Replace the inverter P.C. board.

Yes

If light up, OK.  
If flash, refer to 11-3.

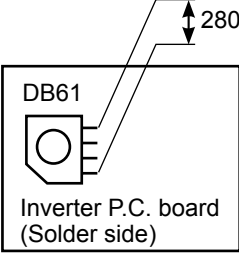

## K How to check miswiring and serial signal error

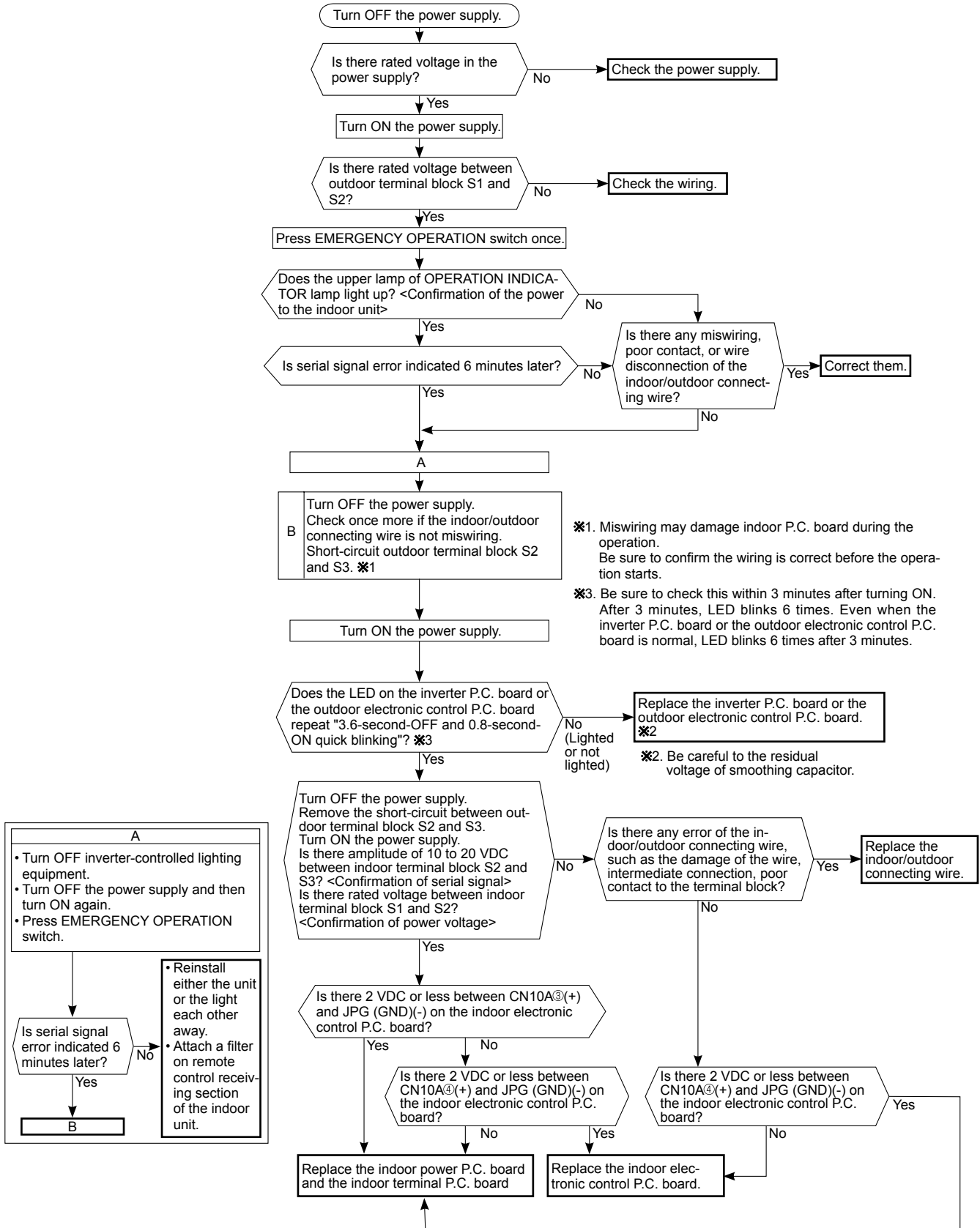

Be sure to release the failure-mode recall function after checking.

## L Check of LEV (Expansion valve)

Turn ON the power supply.

<Preparation of the remote controller>

- ① While pressing both OPERATION SELECT button and TOO COOL button on the remote controller at the same time, press RESET button.
- ② First, release RESET button.  
And release the other two buttons after all LCD except the set temperature in operation display section of the remote controller is displayed after 3 seconds.

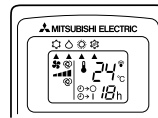
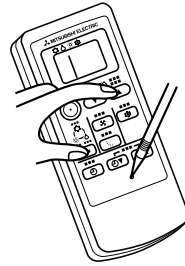

Press OPERATE/STOP (ON/OFF) button of the remote controller (the set temperature is displayed) with the remote controller headed towards the indoor unit. ※1

Expansion valve operates in full-opening direction.

Do you hear the expansion valve "click, click....." ?  
Do you feel the expansion valve vibrate on touching it ?

Yes

OK

No

Is LEV coil properly fixed to the expansion valve?

No

Properly fix the LEV coil to the expansion valve.

Yes

Does the resistance of LEV coil have the characteristics? (Refer to 11-4.)

Yes

Measure each voltage between connector pins of CN724 on the inverter P.C. board.  
1. Pin③(-) — Pin①(+)  
2. Pin④(-) — Pin①(+)  
3. Pin⑤(-) — Pin①(+)  
4. Pin⑥(-) — Pin①(+)  
Is there about 3 ~ 5 VAC between each?  
**NOTE:** Measure the voltage by an analog tester.

No

Replace the inverter P.C. board.

Replace the LEV coil.

Yes

Replace the expansion valve.

※1. Regardless of normal or abnormal condition, a short beep is emitted once the signal is received.

**NOTE :** After check of LEV, do the undermentioned operations.

1. Turn OFF the power supply and turn ON it again.
2. Press RESET button on the remote controller.

## M Electromagnetic noise enters into TV sets or radios

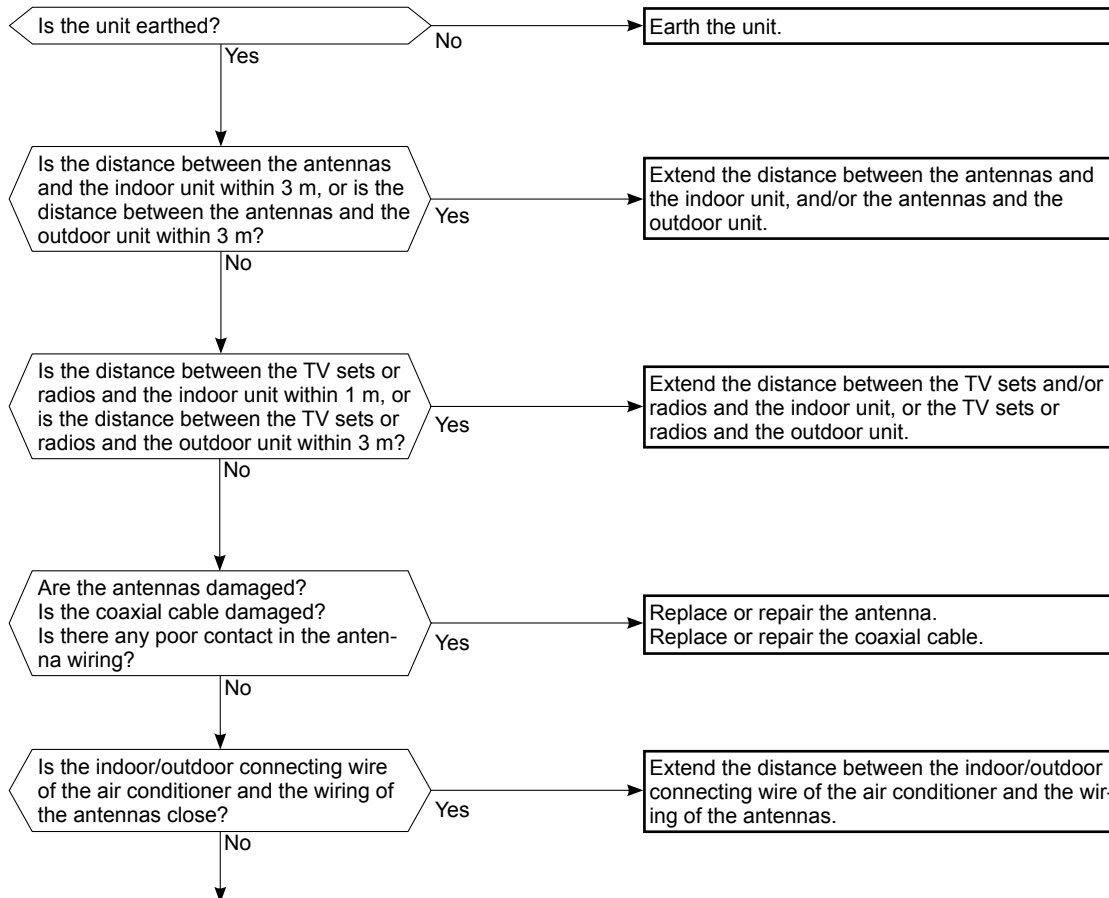

Even if all of the above conditions are fulfilled, the electromagnetic noise may enter, depending on the electric field strength or the installation condition (combination of specific conditions such as antennas or wiring). Check the following before asking for service.

1. Devices affected by the electromagnetic noise  
TV sets, radios (FM/AM broadcast, shortwave)
2. Channel, frequency, broadcast station affected by the electromagnetic noise
3. Channel, frequency, broadcast station unaffected by the electromagnetic noise
4. Layout of ;  
indoor/outdoor unit of the air conditioner, indoor/outdoor wiring, earth wire, antennas, wiring from antennas, receiver
5. Electric field intensity of the broadcast station affected by the electromagnetic noise
6. Presence or absence of amplifier such as booster
7. Operation condition of air conditioner when the electromagnetic noise enters in
  - 1) Turn OFF the power supply once, and then turn ON the power supply. In this situation, check for the electromagnetic noise.
  - 2) Within 3 minutes after turning ON the power supply, press OPERATE/STOP (ON/OFF) button on the remote controller for power ON, and check for the electromagnetic noise.
  - 3) After a short time (3 minutes later after turning ON), the outdoor unit starts running. During operation, check for the electromagnetic noise.
  - 4) Press OPERATE/STOP (ON/OFF) button on the remote controller for power OFF, when the outdoor unit stops but the indoor/outdoor communication still runs on. In this situation, check for the electromagnetic noise.

# 11-6. TEST POINT DIAGRAM AND VOLTAGE

## 1. Inverter P.C. board

### MUZ-HC25VA MUZ-HC35VA MUZ-HC35VAB

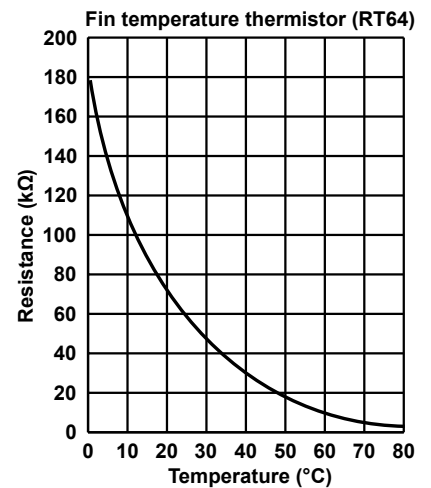
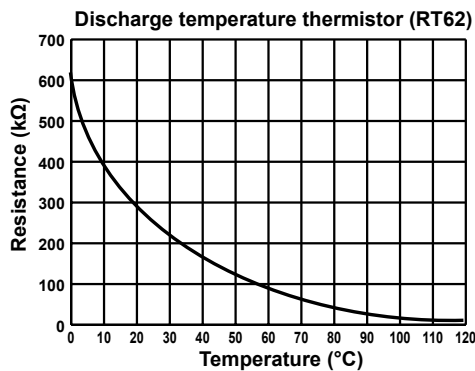
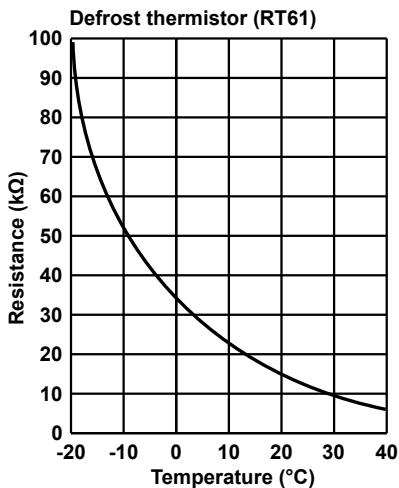
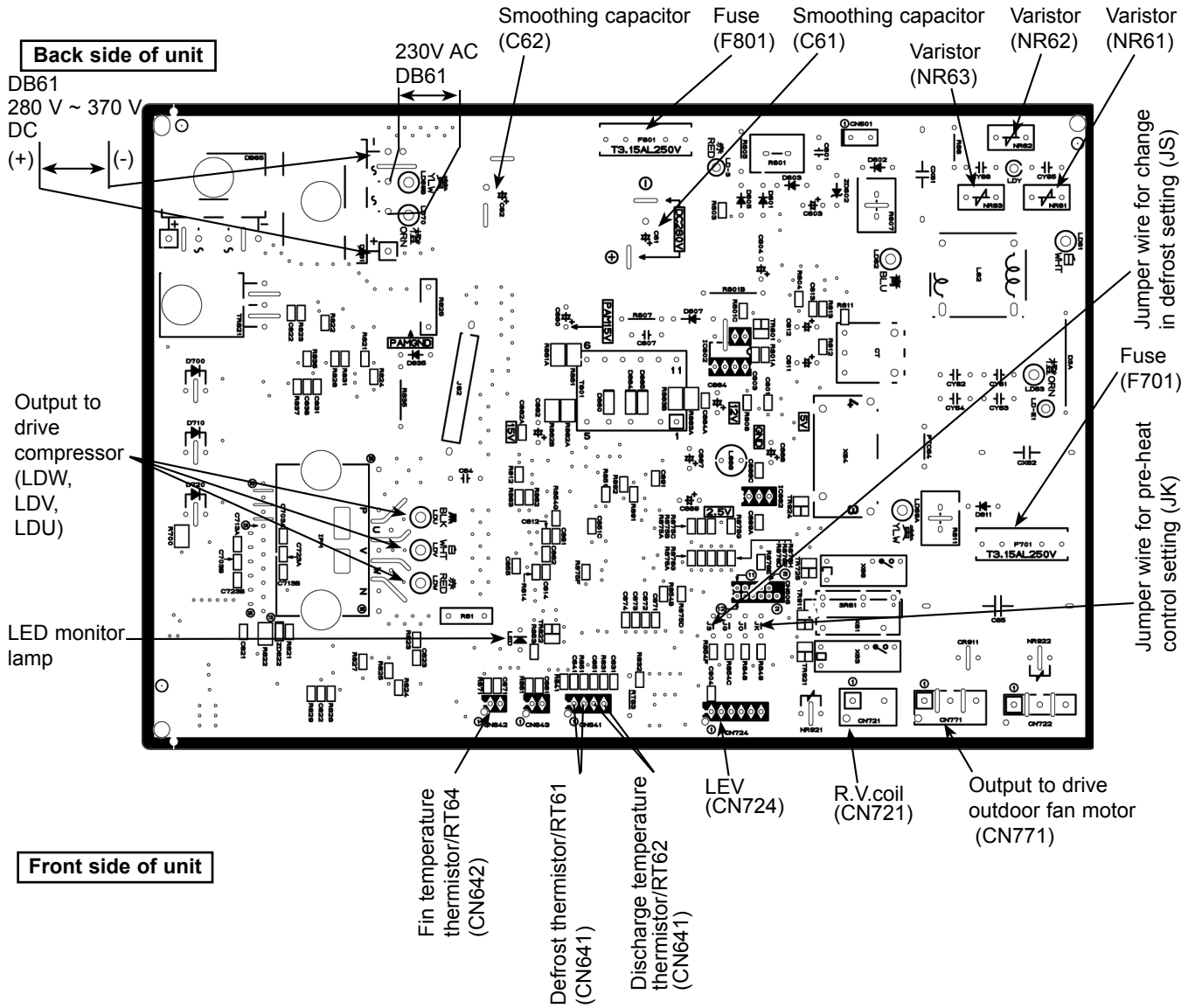

<"Terminal with locking mechanism" Detaching points>

The terminal which has the locking mechanism can be detached as shown below. There are two types (refer to (1) and (2)) of the terminal with locking mechanism. The terminal without locking mechanism can be detached by pulling it out. Check the shape of the terminal before detaching.

(1) Slide the sleeve and check if there is a locking lever or not.

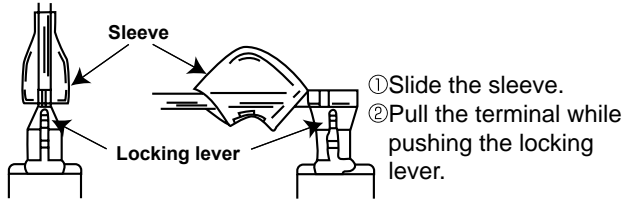

(2) The terminal with this connector has the locking mechanism.

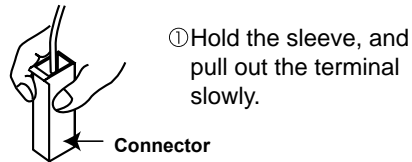

12-1. MUZ-HC25VA MUZ-HC35VA MUZ-HC35VAB

NOTE: Turn OFF power supply before disassembling.

OPERATING PROCEDURE	PHOTOS
<p><b>1. Removing cabinet and panels</b></p> <ol style="list-style-type: none"> <li>(1) Remove the screw fixing the service panel. (Photo 2)</li> <li>(2) Pull down the service panel and remove it. (Photo 2)</li> <li>(3) Disconnect the power supply and indoor/outdoor connecting wire.</li> <li>(4) Remove the screws fixing the top panel. (Photo 1)</li> <li>(5) Remove the top panel. (Photo 1)</li> <li>(6) Remove the screws fixing the cabinet. (Photo 1)</li> <li>(7) Remove the cabinet.</li> <li>(8) Remove the screws fixing the back panel.</li> <li>(9) Remove the back panel.</li> </ol> <p><b>Photo 2</b></p>	<p><b>Photo 1</b></p>



## OPERATING PROCEDURE

## PHOTOS

### 2. Removing the inverter assembly, inverter P.C. board

- (1) Remove the cabinet and panels. (Refer to 1.)
- (2) Disconnect the earth wires (Photo 3), the lead wire to the reactor and the following connectors;  
<Inverter P.C. board>  
CN641 (Defrost thermistor and discharge temperature thermistor)  
CN721 (4-way valve)  
CN771 (Fan motor)
- (3) Disconnect the compressor connector (CN61).
- (4) Remove the screws fixing the relay panel. (Photo 3)
- (5) Remove the inverter assembly. (See Photo 4.)
- (6) Remove the inverter P.C. board from the inverter assembly.

Photo 3

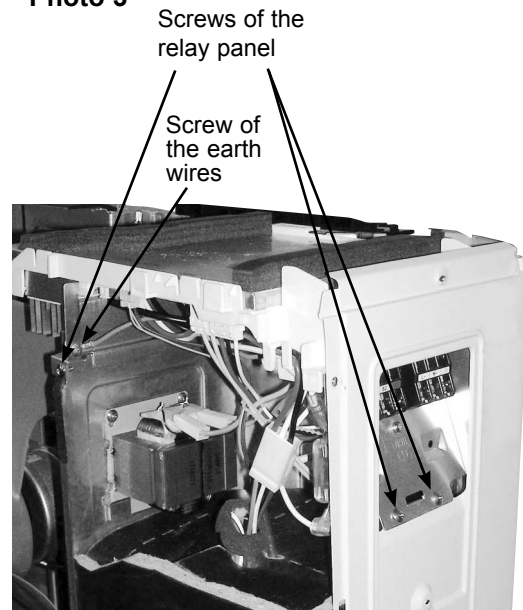

### 3. Removing R.V. coil

- (1) Remove the cabinet and panels. (Refer to 1.)
- (2) Remove the R.V. coil. (Photo 5)

Photo 4 (Inverter assembly)

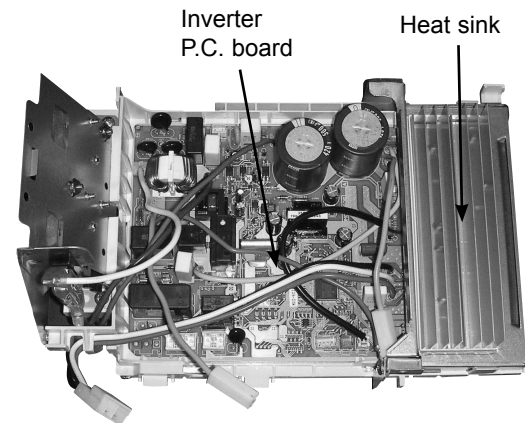

### 4. Removing the discharge temperature thermistor and defrost thermistor

- (1) Remove the cabinet and panels. (Refer to 1.)
- (2) Pull out the discharge temperature thermistor from its holder. (Photo 6)
- (3) Pull out the defrost thermistor from its holder. (Photo 5)

Photo 5

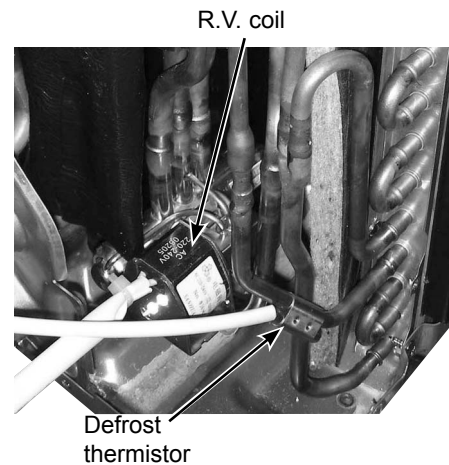

## OPERATING PROCEDURE

### 5. Removing outdoor fan motor

- (1) Remove the cabinet and panels. (Refer to 1.)
- (2) Disconnect the connectors for outdoor fan motor.
- (3) Remove the propeller nut. (Photo 7)
- (4) Remove the propeller. (Photo 7)
- (5) Remove the screws fixing the fan motor. (Photo 7)
- (6) Remove the fan motor.

### 6. Removing the compressor and 4-way valve

- (1) Remove the cabinet and panels. (Refer to 1.)
- (2) Remove the inverter assembly. (Refer to 2.)
- (3) Recover gas from the refrigerant circuit.  
**NOTE** : Recover gas from the pipes until the pressure gauge shows 0 MPa (0 kg/cm<sup>2</sup>).
- (4) Detach the welded part of the suction and the discharge pipe connected with compressor.
- (5) Remove the nuts of compressor legs.
- (6) Remove the compressor.
- (7) Detach the welded part of pipes connected with 4-way valve. (Photo 8)

## PHOTOS

Photo 6



Discharge temperature thermistor

Photo 7

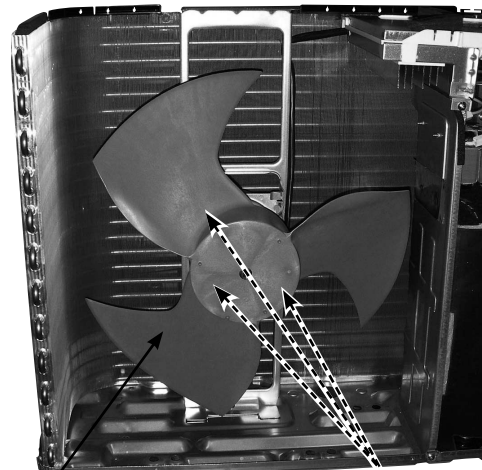

Propeller

Screws of the outdoor fan motor

Photo 8

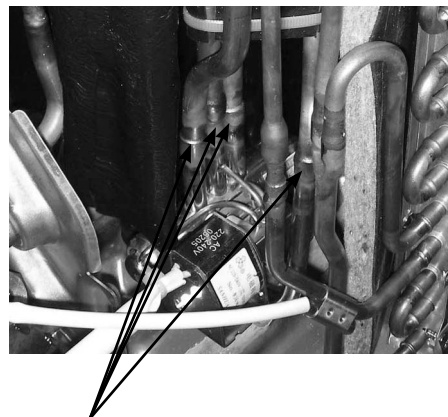

Welded parts of 4-way valve





© Copyright 2007 MITSUBISHI ELECTRIC ENGINEERING CO.,LTD  
Distributed in Aug. 2008. No. OBH467 REVISED EDITION-B 6  
Distributed in Mar. 2007. No. OBH467 REVISED EDITION-A 6  
Distributed in Jan. 2007. No. OBH467 6  
Made in Japan

New publication, effective Aug. 2008  
Specifications subject to change without notice.