

Revision B:

• MSZ-HC35VA-**E2** and MSZ-HC35VAB-**E2**
have been added.

Please void OBH466 REVISED EDITION-A.

INDOOR UNIT SERVICE MANUAL

**No. OBH466
REVISED EDITION-B**

Models

MSZ-HC25VA	-	E1
MSZ-HC35VA	-	E1
MSZ-HC35VA	-	E2
MSZ-HC35VAB	-	E1
MSZ-HC35VAB	-	E2

Outdoor unit service manual
MUZ-HC-VA Series (OBH467)

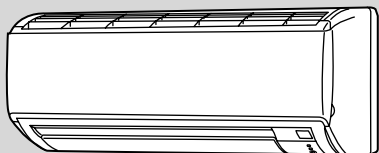

CONTENTS

1. TECHNICAL CHANGES	3
2. PART NAMES AND FUNCTIONS	4
3. SPECIFICATION	5
4. NOISE CRITERIA CURVES	6
5. OUTLINES AND DIMENSIONS	7
6. WIRING DIAGRAM	7
7. REFRIGERANT SYSTEM DIAGRAM	9
8. SERVICE FUNCTIONS	10
9. MICROPROCESSOR CONTROL	12
10. TROUBLESHOOTING	17
11. DISASSEMBLY INSTRUCTIONS	29

PARTS CATALOG (OBB466)

NOTE:
RoHS compliant products have <G> mark on the spec name plate.



Revision A:

- 10. TROUBLESHOOTING has been corrected.
- Color of lead wire (indoor fan motor : sensor part) of 10-5. "Trouble criterion of main parts" has been corrected.
- 10-6."ⒶCheck of indoor fan motor" has been corrected. [MSZ-HC25]

Revision B:

- MSZ-HC35VA-E2 and MSZ-HC35VAB-E2 have been added.
Indoor coil thermistor (RT13) has been added.

1

TECHNICAL CHANGES

MSZ-HA25VA - [E1] → MSZ-HC25VA - [E1]

MSZ-HA35VA - [E1] → MSZ-HC35VA - [E1]

MSZ-HA35VA - [E1] → MSZ-HC35VAB - [E1]

1. Indoor fan motor has been changed. (DC → AC) [MSZ-HC25]
2. Indoor heat exchanger has been changed. [MSZ-HC35]
3. Indoor electronic control P.C. board has been changed.

MSZ-HC35VA - [E1] → MSZ-HC35VA - [E2]

MSZ-HC35VAB - [E1] → MSZ-HC35VAB - [E2]

1. Wiring diagram has been changed.

2

PART NAMES AND FUNCTIONS

MSZ-HC25VA MSZ-HC35VA MSZ-HC35VAB

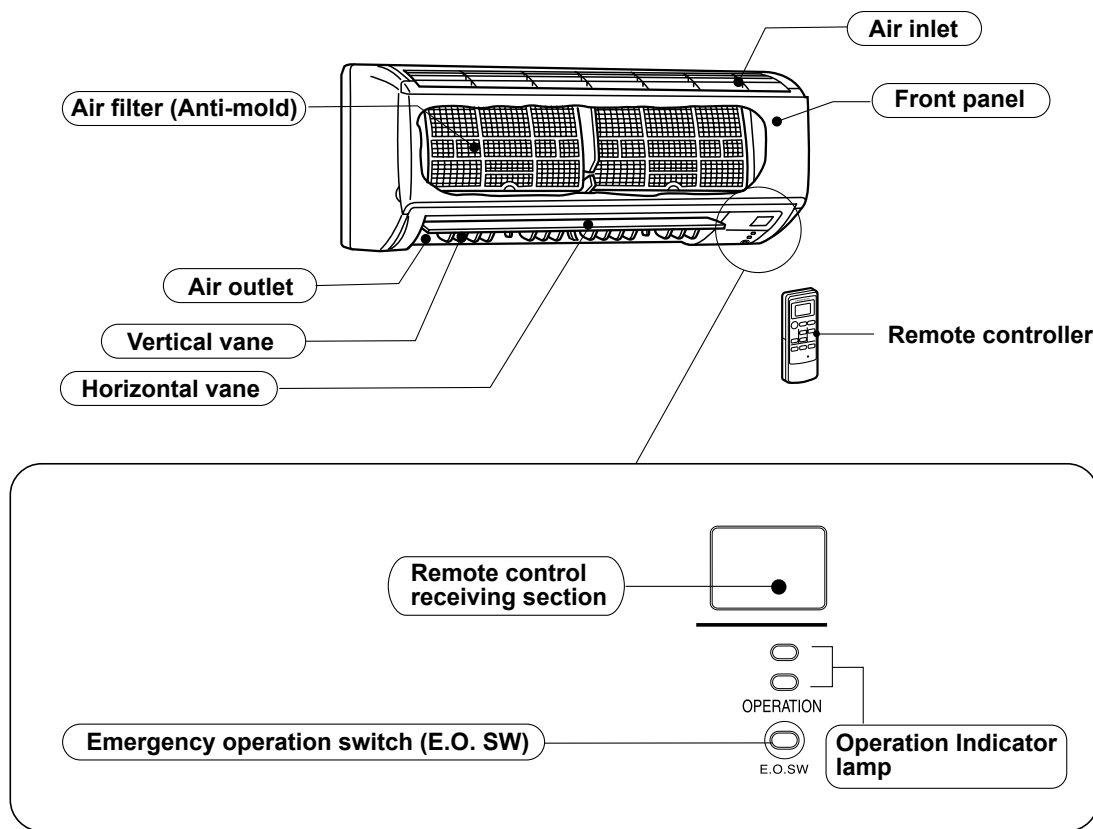

ACCESSORIES

①	Installation plate	1
②	Installation plate fixing screw 4 × 25 mm	5
③	Battery (AAA) for remote controller	2
④	Wireless remote controller	1
⑤	Felt tape (Used for left or left-rear piping)	1

3

SPECIFICATION

Indoor model			MSZ-HC25VA		MSZ-HC35VA		MSZ-HC35VAB	
Function			Cooling	Heating	Cooling	Heating	Cooling	Heating
Power supply			Single phase, 230 V, 50 Hz					
Electrical data	Running current *1	A	0.22					
	Power input *1	W	40		23			
Fan motor	Model		RC4V18-BA or CA		RC0J40-ED			
	Current *1	A	0.22					
Dimensions W × H × D		mm	788×295×225					
Weight		kg	9					
Special remarks	Air flow	(Super High)	630	546	612	552	612	552
		(High/Med./Low)	522/420/318	468/390/306	504/408/312	480/402/294	504/408/312	480/402/294
	Air direction		4					
	Sound level	(Super High)	43					
		(High/Med./Low)	38/32/26					
	Fan speed	(Super High)	1,110	980	1,140	1,050	1,140	1,050
		(High/Med./Low)	950/800/650	870/750/630	980/830/680	940/820/660	980/830/680	940/820/660
	Fan speed regulator		4					
Remote controller model			MP06B					

NOTE : Test conditions are based on ISO 5151.

Cooling : Indoor Dry-bulb temperature 27°C Wet-bulb temperature 19°C

 Outdoor Dry-bulb temperature 35°C

Heating : Indoor Dry-bulb temperature 20°C

 Outdoor Dry-bulb temperature 7°C

Wet-bulb temperature 6°C

Refrigerant piping length (one way) : 5 m

*1 Measured under rated operating frequency.

Specifications and rating conditions of main electric parts

Fuse	(F11)	T3.15A/250V
Horizontal vane motor	(MV)	12 VDC
Varistor	(NR11)	S10K320E3K1 (ERZV14D471)
Terminal block	(TB)	3P

4

NOISE CRITERIA CURVES

MSZ-HC25VA

FAN SPEED	FUNCTION	SPL(dB(A))	LINE
Super High	COOLING	43	●—●
	HEATING	43	○—○

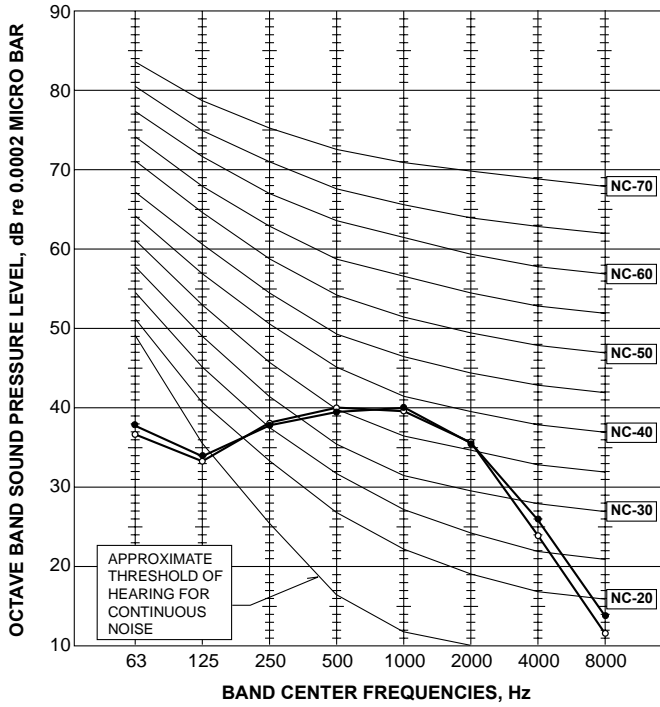

MSZ-HC35VA MSZ-HC35VAB

FAN SPEED	FUNCTION	SPL(dB(A))	LINE
Super High	COOLING	43	●—●
	HEATING	43	○—○

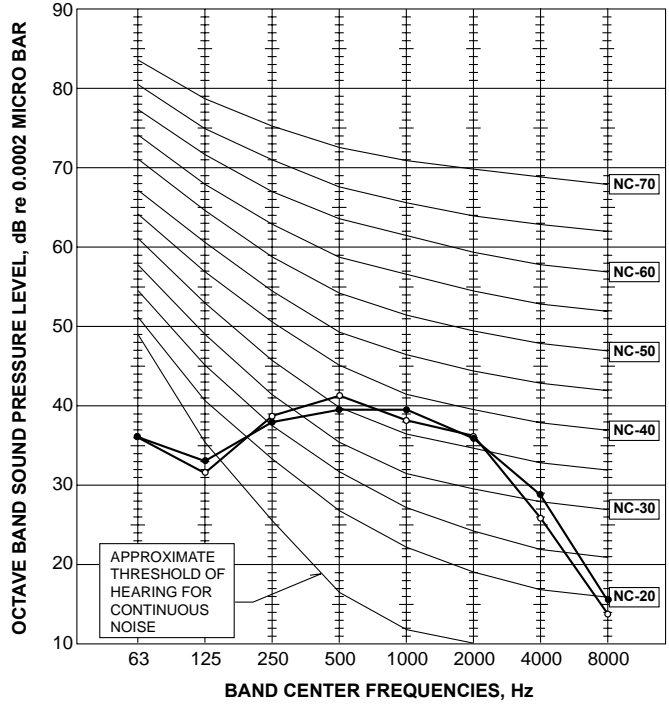

Test conditions

Cooling : Dry-bulb temperature 27°C Wet-bulb temperature 19°C
 Heating : Dry-bulb temperature 20°C

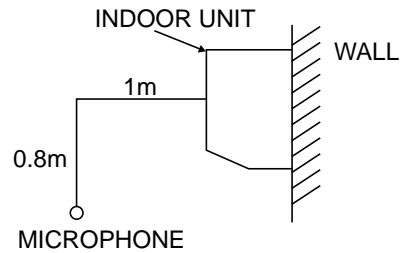

5

OUTLINES AND DIMENSIONS

MSZ-HC25VA MSZ-HC35VA MSZ-HC35VAB

Unit : mm

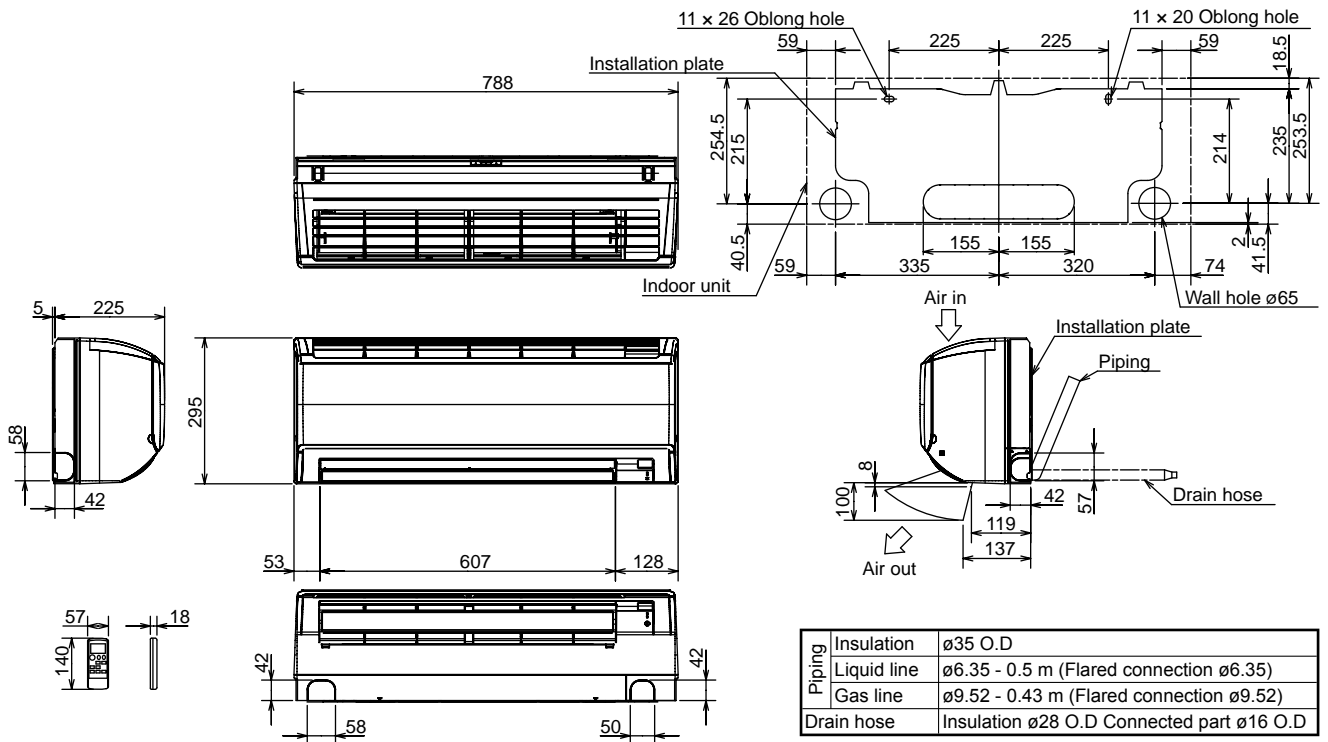

6

WIRING DIAGRAM

MSZ-HC25VA

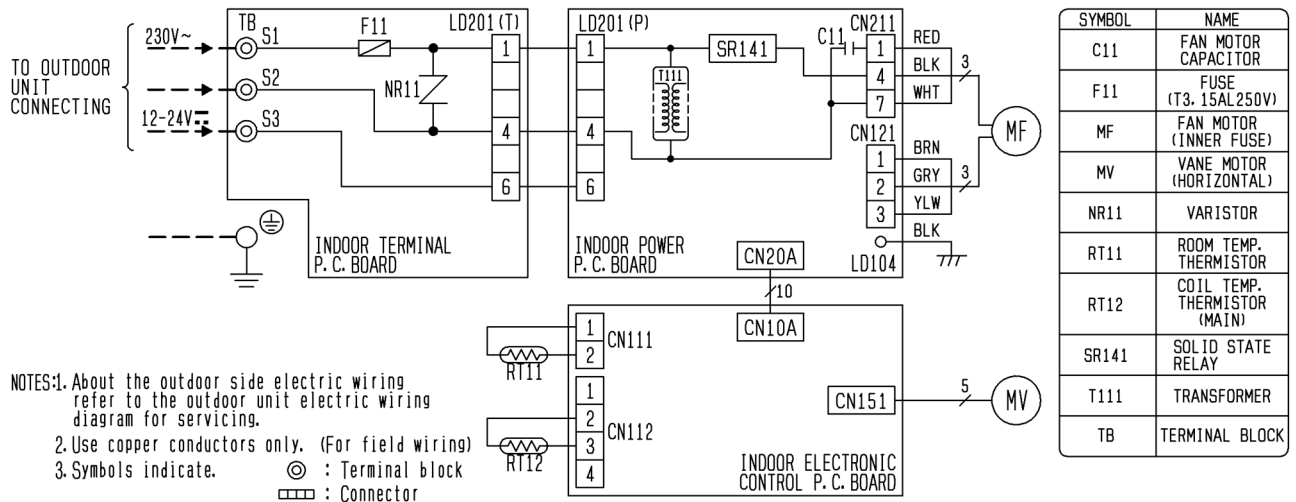

MSZ-HC35VA-E1 MSZ-HC35VAB-E1

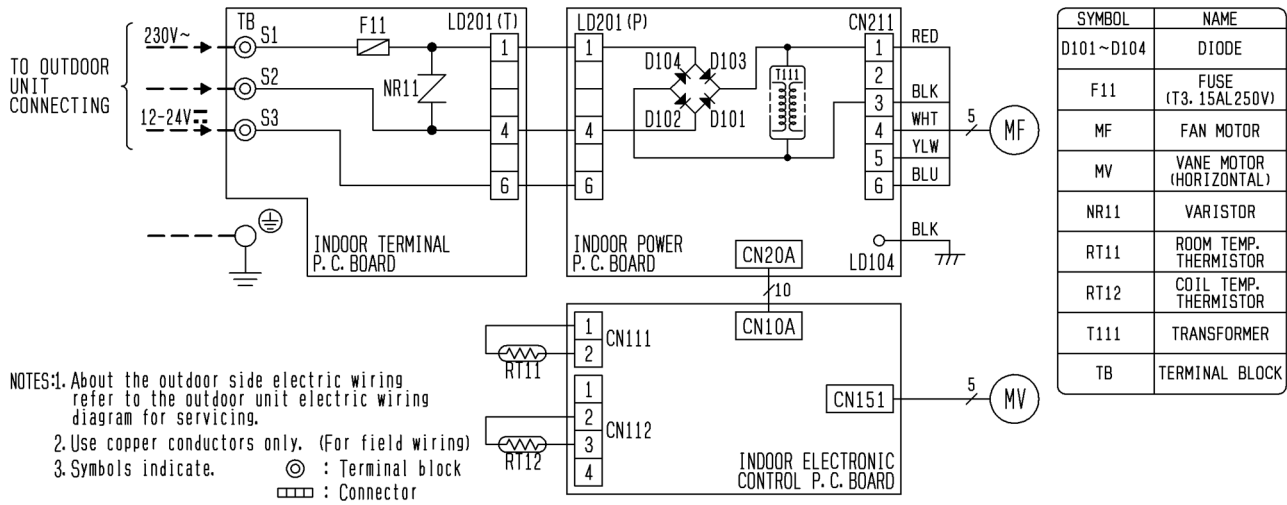

MSZ-HC35VA-E2 MSZ-HC35VAB-E2

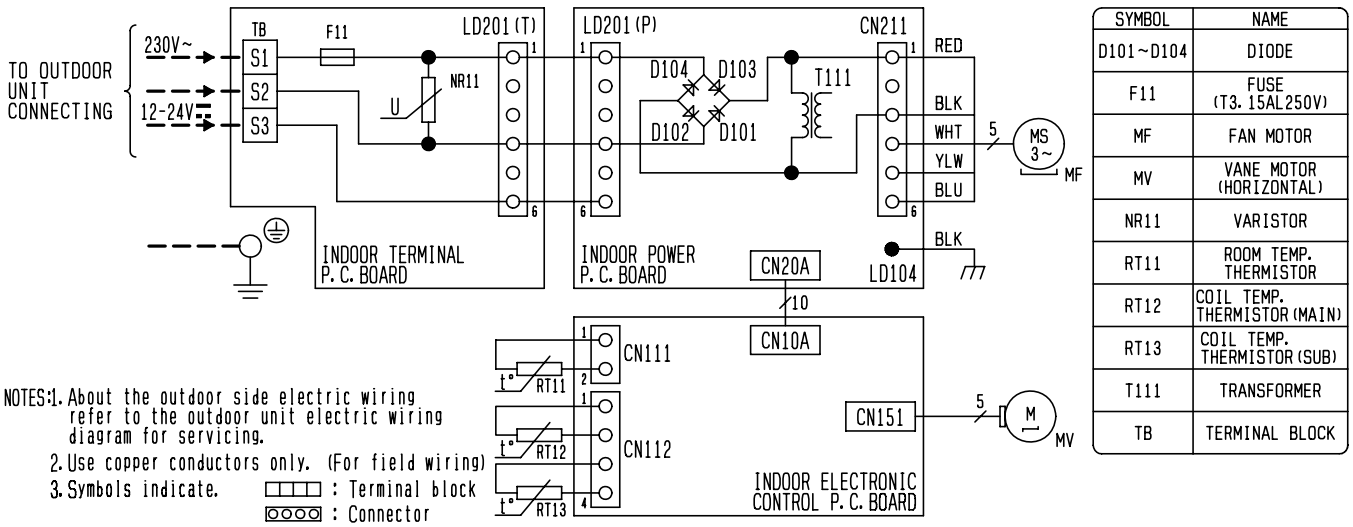

7

REFRIGERANT SYSTEM DIAGRAM

MSZ-HC25VA MSZ-HC35VA-**E1** MSZ-HC35VAB-**E1**

Unit : mm

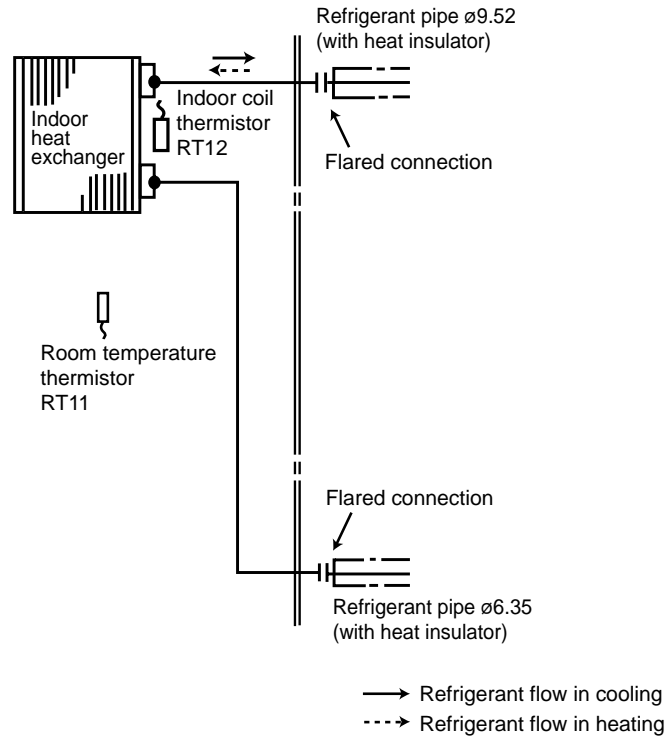

MSZ-HC35VA-**E2** MSZ-HC35VAB-**E2**

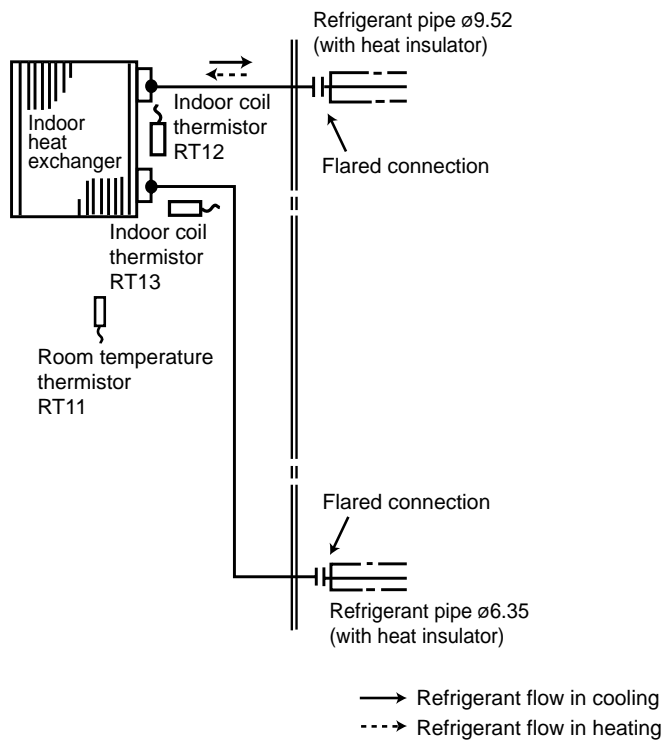

MSZ-HC25VA MSZ-HC35VA MSZ-HC35VAB

8-1. TIMER SHORT MODE

For service, set time can be shortened by short circuit of JPG and JPS on the electronic control P.C. board.

The time will be shortened as follows. (Refer to 10-7.)

Set time : 1-minute → 1-second

Set time : 3-minute → 3-second (It takes 3 minutes for the compressor to start operation. However, the starting time is shortened by short-circuit of JPG and JPS.)

8-2. P.C. BOARD MODIFICATION FOR INDIVIDUAL OPERATION

A maximum of 4 indoor units with wireless remote controllers can be used in a room.

In this case, to operate each indoor unit individually by each remote controller, P.C. boards of remote controller must be modified according to the number of the indoor unit.

How to modify the remote controller P.C. board

Remove batteries before modification.

The board has a print as shown below :

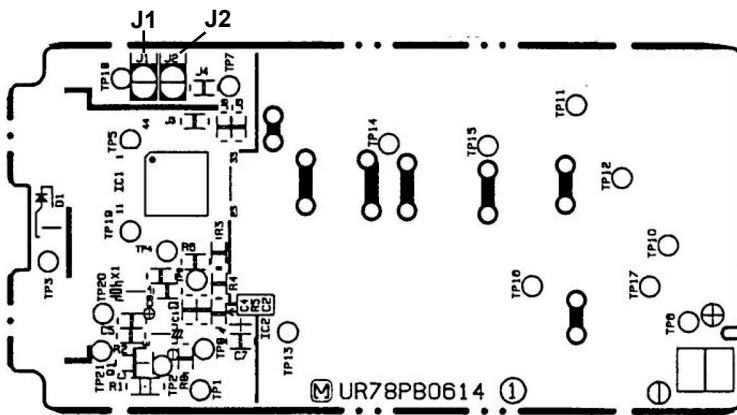

NOTE : For modification, take out the batteries and press the OPERATE/STOP (ON/OFF) button twice or 3 times at first. After finish modification, put back the batteries then press the RESET button.

The P.C. board has the print "J1" and "J2". Solder "J1" and "J2" according to the number of indoor unit as shown in Table 1. After modification, press the RESET button.

Table 1

	1 unit operation	2 units operation	3 units operation	4 units operation
No. 1 unit	No modification	Same as at left	Same as at left	Same as at left
No. 2 unit	—	Solder J1	Same as at left	Same as at left
No. 3 unit	—	—	Solder J2	Same as at left
No. 4 unit	—	—	—	Solder both J1 and J2

How to set the remote controller exclusively for particular indoor unit

After you turn the breaker ON, the first remote controller that sends the signal to the indoor unit will be regarded as the remote controller for the indoor unit.

The indoor unit will only accept the signal from the remote controller that has been assigned to the indoor unit once they are set.

The setting will be cancelled if the breaker has turned OFF, or the power supply has shut down.

Please conduct the above setting once again after the power has restored.

8-3. AUTO RESTART FUNCTION

When the indoor unit is controlled with the remote controller, the operation mode, the set temperature, and the fan speed are memorized by the indoor electronic control P.C. board. "AUTO RESTART FUNCTION" automatically starts operation in the same mode just before the shutoff of the main power.

Operation

- ① If the main power has been cut, the operation settings remain.
- ② After the power is restored, the unit restarts automatically according to the memory.
(However, it takes at least 3 minutes for the compressor to start running.)

How to release "AUTO RESTART FUNCTION"

- ① Turn off the main power for the unit.
- ② Solder the Jumper wire to JR07 on the indoor electronic control P.C. board. (Refer to 10-7.)

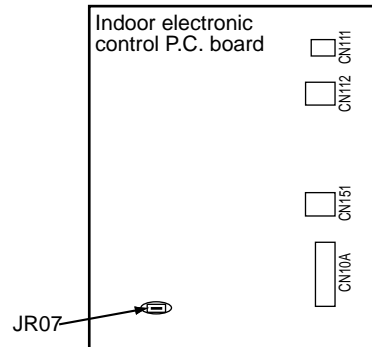

NOTE:

- The operation settings are memorized when 10 seconds have passed after the indoor unit was operated with the remote controller.
- If main power is turned OFF or a power failure occurs while AUTO START/STOP timer is active, the timer setting is cancelled.
- If the unit has been off with the remote controller before power failure, the auto restart function does not work as the power button of the remote controller is off.
- To prevent breaker OFF due to the rush of starting current, systematize other home appliance not to turn ON at the same time.
- When some air conditioners are connected to the same supply system, if they are operated before power failure, the starting current of all the compressors may flow simultaneously at restart. Therefore, the special counter measures are required to prevent the main voltage-drop or the rush of the starting current by adding to the system that allows the units to start one by one.

MSZ-HC25VA MSZ-HC35VA MSZ-HC35VAB

WIRELESS REMOTE CONTROLLER

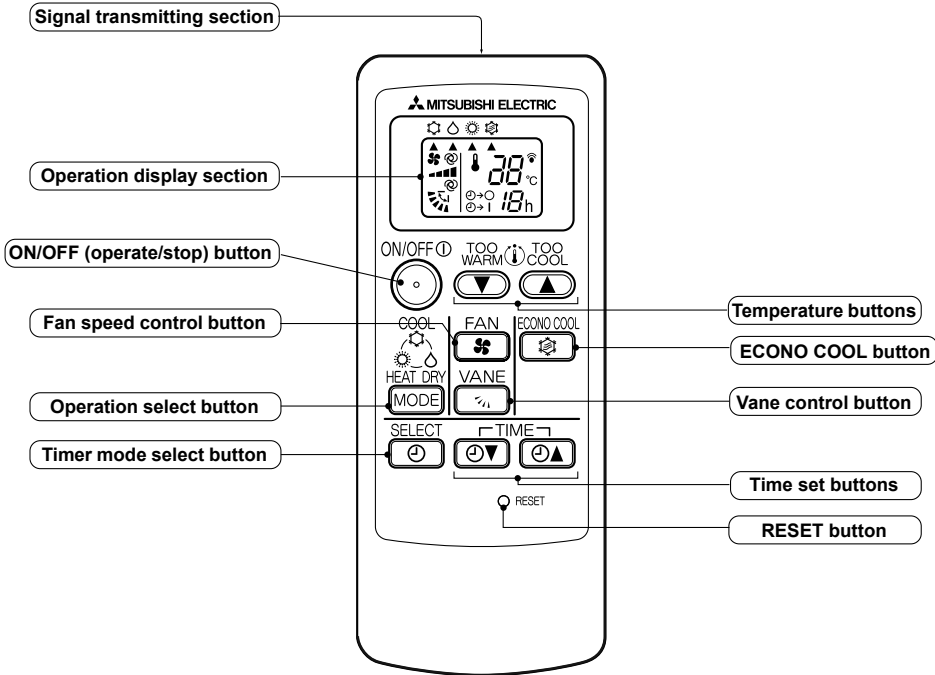

NOTE : Last setting will be stored after the unit is turned OFF with the remote controller. Indoor unit receives the signal of the remote controller with beeps.

INDOOR UNIT DISPLAY SECTION

Operation Indicator lamp

The operation indicator at the right side of the indoor unit indicates the operation state.

- The following indication applies regardless of shape of shape of the indication.

Indication	Operation state	Room temperature
	The unit is operating to reach the set temperature	About 2°C or more away from set temperature
	The room temperature is approaching the set temperature	About 1 to 2°C from set temperature

- Lighted
- Blinking
- Not lighted

9-1. COOL (❄️) OPERATION

- (1) Press OPERATE/STOP (ON/OFF) button.
OPERATION INDICATOR lamp of the indoor unit turns on with a beep tone.
- (2) Select COOL mode with OPERATION SELECT button.
- (3) Press TEMPERATURE buttons (TOO WARM or TOO COOL button) to select the desired temperature.
The setting range is 16 ~ 31°C.

1. Coil frost prevention

The compressor operational frequency is controlled by the temperature of the indoor heat exchanger to prevent the coil from frosting.
When the temperature of indoor heat exchanger becomes too low, the coil frost prevention mode works. The indoor fan operates at the set speed and the compressor stops. This mode continues until the temperature of indoor heat exchanger rises.

9-2. DRY (☀️) OPERATION

- (1) Press OPERATE/STOP (ON/OFF) button.
OPERATION INDICATOR lamp of the indoor unit turns on with a beep tone.
- (2) Select DRY mode with OPERATION SELECT button.
- (3) The set temperature is determined from the initial room temperature.

1. Coil frost prevention

Coil frost prevention is as same as COOL mode. (9-1.1.)

9-3. HEAT (🔥) OPERATION

- (1) Press OPERATE/STOP (ON/OFF) button.
OPERATION INDICATOR lamp of the indoor unit turns on with a beep tone.
- (2) Select HEAT mode with OPERATION SELECT button.
- (3) Press TEMPERATURE buttons (TOO WARM or TOO COOL button) to select the desired temperature.
The setting range is 16 ~ 31°C.

1. Cold air prevention control

When the compressor is not operating or is starting, and the temperature of indoor heat exchanger and/or the room temperature is low or when defrosting is being done, the indoor fan will stop or rotate in Very Low speed.

2. High pressure protection

The compressor operational frequency is controlled by the temperature of the indoor heat exchanger to prevent the condensing pressure from increasing excessively.

When the temperature of indoor heat exchanger becomes too high, the high pressure protection works.

The indoor fan operates following the cold air prevention control. This mode continues until the temperature of indoor heat exchanger falls.

3. Defrosting

Defrosting starts when the temperature of outdoor heat exchanger becomes too low.

The compressor stops once, the indoor/outdoor fans stop, the 4-way valve reverses, and the compressor re-starts.

This mode continues until the temperature of outdoor heat exchanger rises or the fixed time passes.

9-4. AUTO VANE OPERATION

1. Horizontal vane

(1) Vane motor drive

These models are equipped with a stepping motor for the horizontal vane. The rotating direction, speed, and angle of the motor are controlled by pulse signals (approx. 12 V) transmitted from indoor microprocessor.

(2) The horizontal vane angle and mode change as follows by pressing VANE CONTROL button.

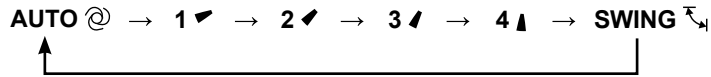

(3) Positioning

To confirm the standard position, the vane moves until it touches the vane stopper. Then the vane is set to the selected angle.

Confirming of standard position is performed in the following cases:

- (a) When the operation starts or finishes (including timer operation).
- (b) When the test run starts.

(4) VANE AUTO (⊙) mode

In VANE AUTO mode, the microprocessor automatically determines the vane angle to make the optimum room temperature distribution.

In COOL and DRY operation

Vane angle is fixed to Horizontal position.



In HEAT operation

Vane angle is fixed to Angle 4.

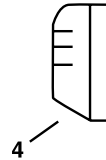

(5) STOP (operation OFF) and ON TIMER standby

In the following cases, the horizontal vane returns to the closed position.

- (a) When OPERATE/STOP (ON/OFF) button is pressed (POWER OFF).
- (b) When the operation is stopped by the emergency operation.
- (c) When ON TIMER is ON standby.

(6) Dew prevention

During COOL or DRY operation with the vane angle at Angle 2 ~ 4 when the compressor cumulative operation time exceeds 1 hour, the vane angle automatically changes to Angle 1 for dew prevention.

(7) SWING (↕) mode



By selecting SWING mode with VANE CONTROL button, the horizontal vane swings vertically.

(8) Cold air prevention in HEAT operation.

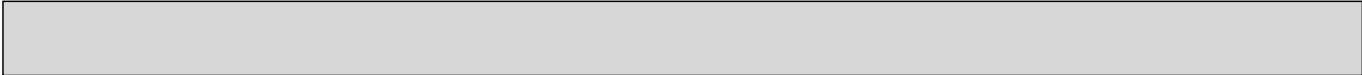
The horizontal vane position is set to Upward.



(9) To change the airflow direction not to blow directly onto your body.

To change the airflow direction	When to use this function?	COOL/DRY	HEAT
Pressing and holding VANE CONTROL button for 2 seconds or more cause the horizontal vane to reverse and move to horizontal position. 	Use this function if you don't want the air from the indoor unit to blow directly onto your body. <ul style="list-style-type: none"> Depending on the shape of the room, the air may blow directly onto your body. Press VANE CONTROL button again to return the vane to the previously-set position. 	The air conditioner starts the cooling or drying operation approx. 3 minutes after the vane has moved to the horizontal position. <ul style="list-style-type: none"> When VANE CONTROL button is pressed again, the vane returns to the previously-set position and the air conditioner starts the cool or dry operation in approx. 3 minutes. 	The air conditioner starts heating operation approx. 3 minutes after the vane has moved to the horizontal position. <ul style="list-style-type: none"> Sometimes the area around your feet may not warm. To warm the area around the feet, set the horizontal vane to  (AUTO) or the downward-blowing position. When VANE CONTROL button is pressed again, the vane returns to the previously-set position and the air conditioner starts the heat operation in approx. 3 minutes.

NOTE :

- If you make the airflow not to blow directly onto your body by pressing VANE CONTROL button, the compressor stops for 3 minutes even during the operation of the air conditioner.
- The air conditioner operates with Very Low speed until the compressor turns on again.

(10) ECONO COOL (🌀) operation (ECONOMical operation)

When ECONO COOL button is pressed in COOL mode, set temperature is automatically set 2°C higher.



Also the horizontal vane swings in various cycle.

SWING operation makes you feel cooler than set temperature. So, even though the set temperature is higher, the air conditioner can keep comfort. As a result, energy can be saved.

ECONO COOL operation is cancelled when ECONO COOL button is pressed once again or VANE CONTROL button is pressed or change to other operation mode.

9-5. TIMER OPERATION (ON/OFF TIMER)

1. How to set the timer

- (1) Press OPERATE/STOP (ON/OFF) button to start the air conditioner.
- (2) Select the timer mode by pressing the  button during operation.
Each time this button is pressed, the timer mode is changed in sequence:
☉→○ (OFF TIMER) → ☉→| (ON TIMER) → TIMER RELEASE
- (3) Set the time of the timer using the  button.
Each time this button is pressed, the set time increase or decrease by 1 hour to 12 hours.

2. To release the timer

Press the  button until ☉→○ (OFF TIMER) and ☉→| (ON TIMER) are not displayed.

NOTE :

- The OFF TIMER and the ON TIMER cannot be set at the same time.
- The displayed time is the time remaining and will decrease in 1-hour increments as time passes.

9-6. EMERGENCY/TEST OPERATION

In case of test run operation or emergency operation, use EMERGENCY OPERATION switch on the right side of the indoor unit. Emergency operation is available when the remote controller is missing, has failed or the batteries of the remote controller run down. The unit will start and OPERATION INDICATOR lamp will light.

The first 30 minutes of operation is the test run operation. This operation is for servicing. The indoor fan runs at High speed and the system is in continuous operation (The thermostat does not work).

After 30 minutes of test run operation, the system shifts to EMERGENCY COOL/HEAT MODE with a set temperature of 24°C. The fan speed shifts to Med..

In the test run or emergency operation, the horizontal vane operates in VANE AUTO (@) mode.

Emergency operation continues until EMERGENCY OPERATION switch is pressed once or twice or the unit receives any signal from the remote controller. In case of latter, normal operation will start.

NOTE : Do not press EMERGENCY OPERATION switch during normal operation.

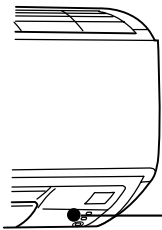

EMERGENCY OPERATION switch



Operation mode	COOL	HEAT
Set temperature	24°C	24°C
Fan speed	Med.	Med.
Horizontal vane	Auto	Auto

The operation mode is indicated by the Operation Indicator lamp as following

Operation Indicator lamp

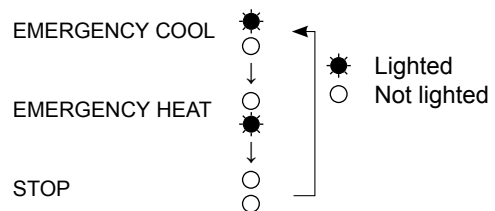

9-7. 3-MINUTE TIME DELAY OPERATION

When the system turns OFF, compressor will not restart for 3 minutes as 3-minute time delay function operates to protect compressor from overload.

MSZ-HC25VA MSZ-HC35VA MSZ-HC35VAB

10-1. CAUTIONS ON TROUBLESHOOTING

1. Before troubleshooting, check the following:

- 1) Check the power supply voltage.
- 2) Check the indoor/outdoor connecting wire for miswiring.

2. Take care of the following during servicing

- 1) Before servicing the air conditioner, be sure to turn OFF the main unit first with the remote controller, and then after confirming the horizontal vane is closed, turn OFF the breaker and/or disconnect the power plug.
- 2) Be sure to turn OFF the power supply before removing the front panel, the cabinet, the top panel, and the P.C. board.
- 3) When removing the P.C. board, hold the edge of the board with care NOT to apply stress on the components.
- 4) When connecting or disconnecting the connectors, hold the housing of the connector. DO NOT pull the lead wires.

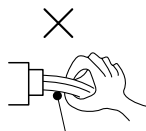

Lead wiring

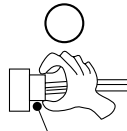

Housing point

3. Troubleshooting procedure

- 1) First, check if the OPERATION INDICATOR lamp on the indoor unit is flashing on and off to indicate an abnormality. To make sure, check how many times the abnormality indication is flashing on and off before starting service work.
- 2) Before servicing check that the connector and terminal are connected properly.
- 3) If the P.C. board is supposed to be defective, check the copper foil pattern for disconnection and the components for bursting and discoloration.
- 4) When troubleshooting, refer to 10-2., 10-3. and 10-4.

4. How to replace batteries

Weak batteries may cause the remote controller malfunction.

In this case, replace the batteries to operate the remote controller normally.

- ① Remove the back lid and insert batteries. Then reattach the back lid.

- ② Press RESET button with a thin instrument, and then use the remote controller.

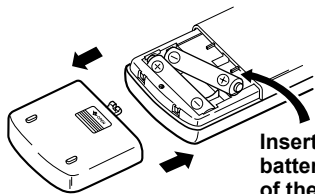

Insert the minus pole of the batteries first. Check if the polarity of the batteries is correct.

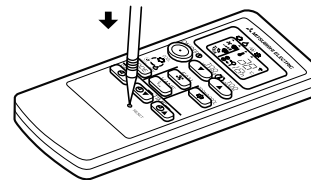

NOTE : 1. If RESET button is not pressed, the remote controller may not operate correctly.

2. This remote controller has a circuit to automatically reset the microcomputer when batteries are replaced. This function is equipped to prevent the microcomputer from malfunctioning due to the voltage drop caused by the battery replacement.

10-2. FAILURE MODE RECALL FUNCTION

Outline of the function

This air conditioner can memorize the abnormal condition which has occurred once.

Even though LED indication listed on the troubleshooting check table (10-4.) disappears, the memorized failure details can be recalled.

This mode is very useful when the unit needs to be repaired for the abnormality which doesn't recur.

1. Flow chart of failure mode recall function for the indoor/outdoor unit

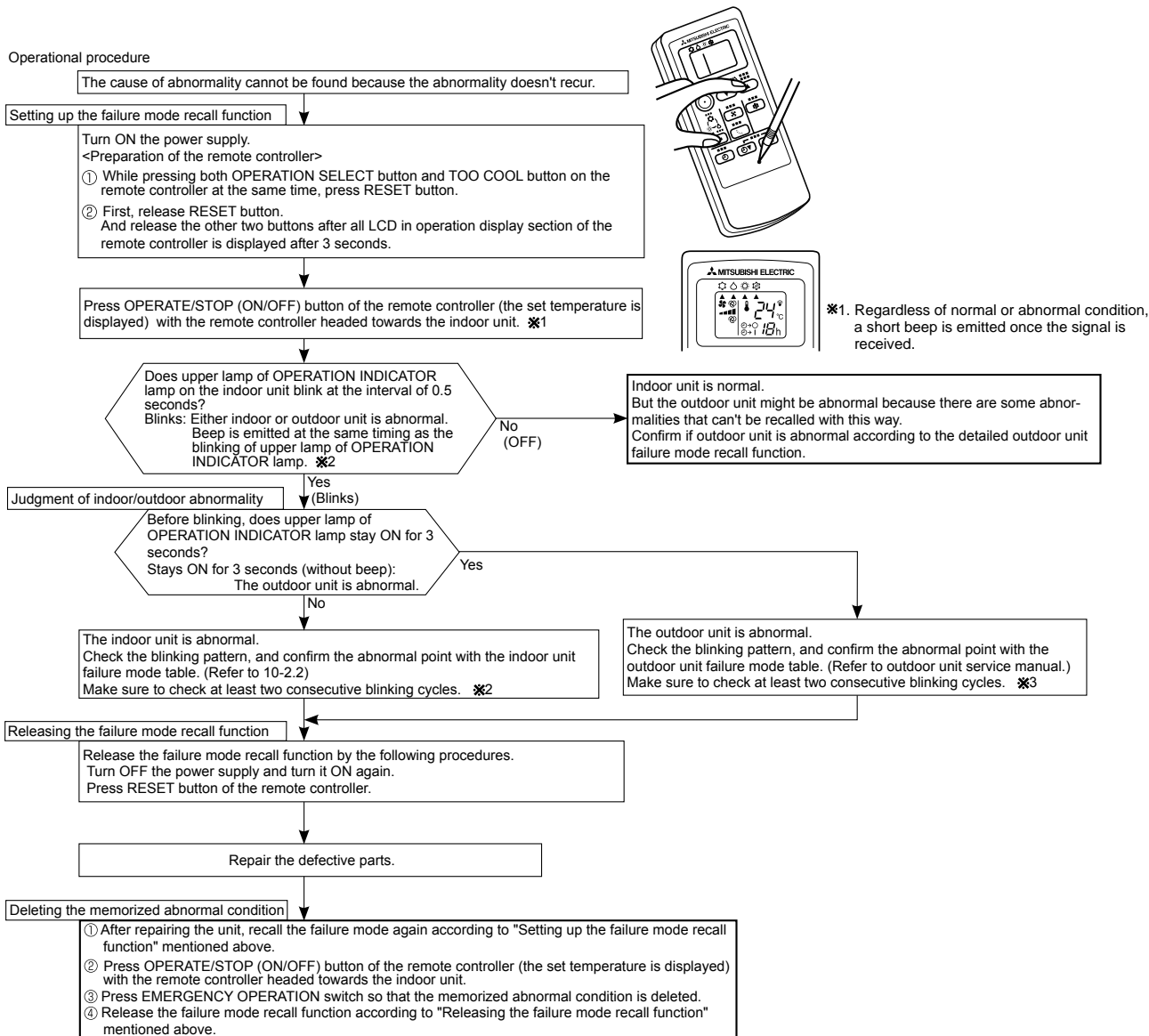

NOTE: 1. Make sure to release the failure mode recall function once it's set up, otherwise the unit cannot operate properly.
 2. If the abnormal condition is not deleted from the memory, the last abnormal condition is kept memorized.

※2. Blinking pattern when the indoor unit is abnormal:

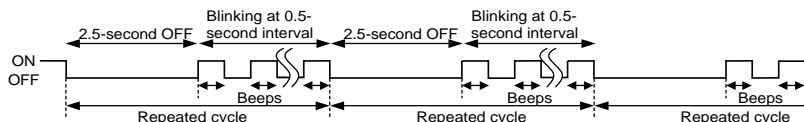

※3. Blinking pattern when the outdoor unit is abnormal:

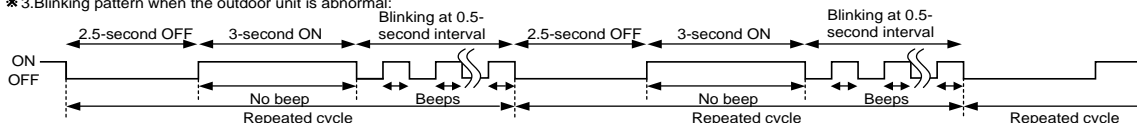



2. Indoor unit failure mode table

Upper lamp of OPERATION INDICATOR lamp	Abnormal point (Failure mode)	Condition	Correspondence
Not lighted	Normal	—	—
1-time flash every 0.5-second	Room temperature thermistor	The room temperature thermistor short or open circuit is detected every 8 seconds during operation.	Refer to the characteristics of the room temperature thermistor (10-7.).
2-time flash 2.5-second OFF	Indoor coil thermistor	The indoor coil thermistor short or open circuit is detected every 8 seconds during operation.	Refer to the characteristics of the main indoor coil thermistor, the sub indoor coil thermistor (10-7.).
3-time flash 2.5-second OFF	Serial signal	The serial signal from outdoor unit is not received for a maximum of 6 minutes.	Refer to 10-6.Ⓒ "How to check miswiring and serial signal error".
11-time flash 2.5-second OFF	Indoor fan motor	The rotational frequency feedback signal is not emit during the 12 seconds the indoor fan operation.	Refer to 10-6.Ⓐ "Check of indoor fan motor".
12-time flash 2.5-second OFF	Indoor control system	It cannot properly read data in the nonvolatile memory of the indoor electronic control P.C. board.	Replace the indoor electronic control P.C. board.

NOTE : Blinking patterns of this mode differ from the ones of TROUBLESHOOTING CHECK TABLE (10-4.).

10-3. INSTRUCTION OF TROUBLESHOOTING

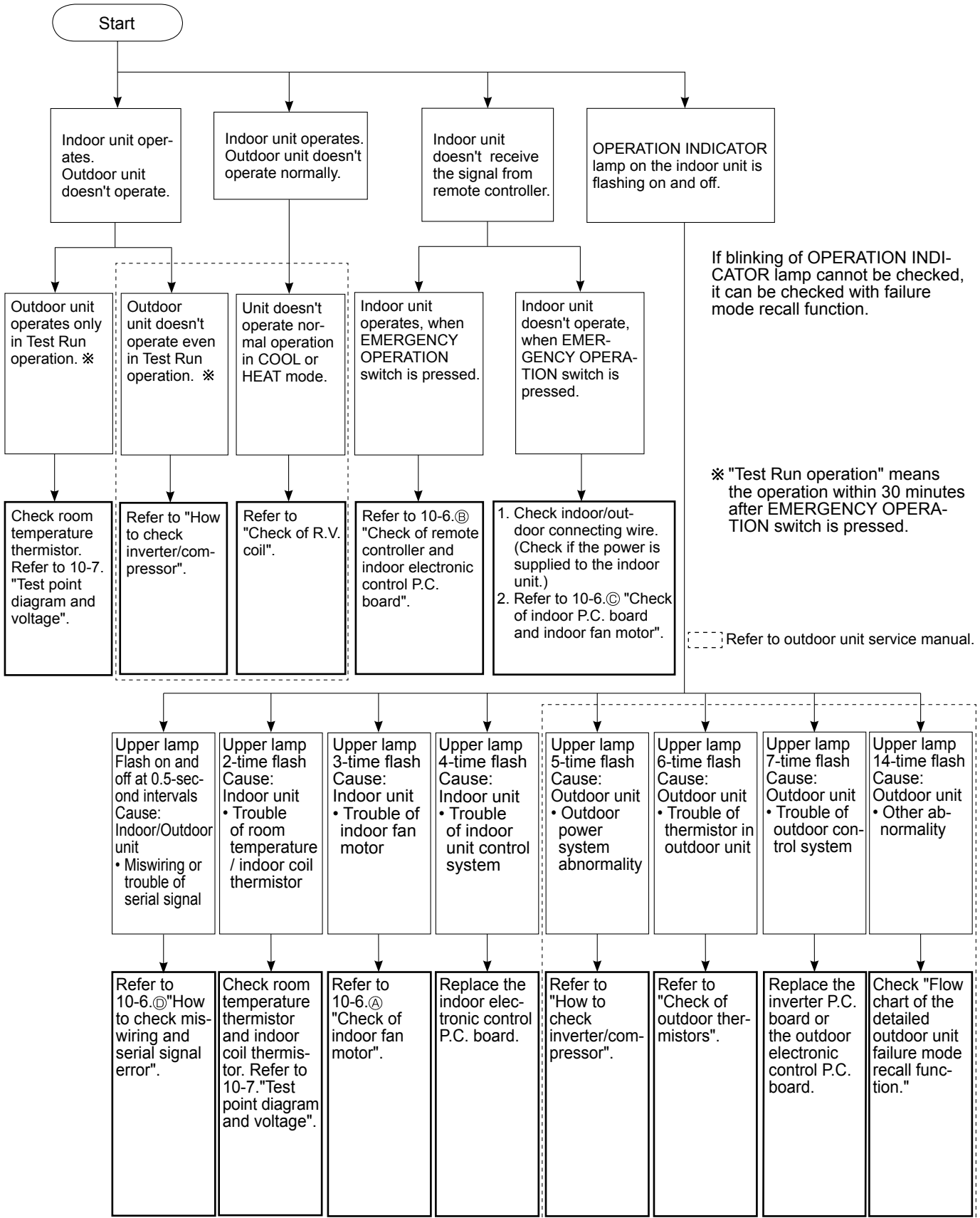

10-4. TROUBLESHOOTING CHECK TABLE

Before taking measures, make sure that the symptom reappears for accurate troubleshooting. When the indoor unit has started operation and detected an abnormality of the following condition (the first detection after the power ON), the indoor fan motor turns OFF and OPERATION INDICATOR lamp flashes.

OPERATION INDICATOR



No.	Abnormal point	Operation indicator lamp	Symptom	Condition	Correspondence
1	Miswiring or serial signal	Upper lamp flashes. 0.5-second ON ●○●○●○●○ 0.5-second OFF	Indoor unit and outdoor unit do not operate.	The serial signal from the outdoor unit is not received for 6 minutes.	• Refer to 10-6. ③ "How to check miswiring and serial signal error".
2	Indoor coil thermistor Room temperature thermistor	Upper lamp flashes. 2-time flash ●○●○●○●○●○●○●○ 2.5-second OFF		The indoor coil or the room temperature thermistor is short or open circuit.	• Refer to 10-7. the characteristics of indoor coil thermistor, and the room temperature thermistor.
3	Indoor fan motor	Upper lamp flashes. 3-time flash ●○●○●○●○●○●○●○●○●○●○ 2.5-second OFF		The rotational frequency feedback signal is not emitted during the indoor fan operation.	• Refer to 10-6. ④ "Check of indoor fan motor".
4	Indoor control system	Upper lamp flashes. 4-time flash ●○●○●○●○●○●○●○●○●○●○●○●○●○ 2.5-second OFF		It cannot properly read data in the nonvolatile memory of the indoor electronic control P.C. board.	• Replace the indoor electronic control P.C. board.
5	Outdoor power system	Upper lamp flashes. 5-time flash ●○●○●○●○●○●○●○●○●○●○●○●○●○ 2.5-second OFF		It consecutively occurs 3 times that the compressor stops for overcurrent protection or start-up failure protection within 1 minute after start-up.	• Refer to "How to check of inverter/compressor". Refer to outdoor unit service manual • Check the stop valve.
6	Outdoor thermistors	Upper lamp flashes. 6-time flash ●○●○●○●○●○●○●○●○●○●○●○●○●○ 2.5-second OFF		The outdoor thermistors short or open circuit during the compressor operation.	• Refer to "Check of outdoor thermistor". Refer to outdoor unit service manual.
7	Outdoor control system	Upper lamp flashes. 7-time flash ●○●○●○●○●○●○●○●○●○●○●○●○●○●○●○●○ 2.5-second OFF		It cannot properly read data in the nonvolatile memory of the inverter P.C. board or the outdoor electronic control P.C. board.	• Replace the inverter P.C. board or the outdoor electronic control P.C. board. Refer to outdoor unit service manual.
8	Other abnormality	Upper lamp flashes. 14-time flash ●○ 2.5-second OFF		An abnormality other than above mentioned is detected.	• Check the stop valve. • Confirm the abnormality in detail using the failure mode recall function for outdoor unit.
9	Outdoor control system	Upper lamp lights up ●		Outdoor unit does not operate	It cannot properly read data in the nonvolatile memory of the inverter P.C. board or the outdoor electronic control P.C. board.

10-5. TROUBLE CRITERION OF MAIN PARTS

MSZ-HC25VA MSZ-HC35VA MSZ-HC35VAB

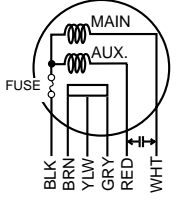
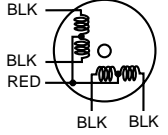
Part name	Check method and criterion	Figure											
Room temperature thermistor (RT11)	Measure the resistance with a tester.												
Indoor coil thermistor (RT12, RT13)	Refer to 10-7. "Test point diagram and voltage", "2. Indoor electronic control P.C. board", the chart of thermistor.												
Indoor fan motor (MF) MSZ-HC25 INNER FUSE BA : 135 ± 3°C CUT OFF CA : 140 ± 2°C CUT OFF	Motor part Measure the resistance between the terminals with a tester. (Part temperature 10 ~ 30°C) <table border="1" style="margin-left: 20px;"> <thead> <tr> <th rowspan="2">Color of lead wire</th> <th colspan="2">Normal</th> </tr> <tr> <th>RC4V18-BA</th> <th>RC4V18-CA</th> </tr> </thead> <tbody> <tr> <td>WHT - BLK</td> <td>273 ~ 296 Ω</td> <td>308 ~ 334 Ω</td> </tr> <tr> <td>BLK - RED</td> <td>295 ~ 320 Ω</td> <td>295 ~ 320 Ω</td> </tr> </tbody> </table>	Color of lead wire	Normal		RC4V18-BA	RC4V18-CA	WHT - BLK	273 ~ 296 Ω	308 ~ 334 Ω	BLK - RED	295 ~ 320 Ω	295 ~ 320 Ω	
	Color of lead wire		Normal										
RC4V18-BA		RC4V18-CA											
WHT - BLK	273 ~ 296 Ω	308 ~ 334 Ω											
BLK - RED	295 ~ 320 Ω	295 ~ 320 Ω											
Sensor part Measure the voltage power ON. <table border="1" style="margin-left: 20px;"> <thead> <tr> <th>Color of lead wire</th> <th>Normal range</th> </tr> </thead> <tbody> <tr> <td>BRN - YLW</td> <td>4.5 ~ 5.5 V</td> </tr> <tr> <td>BRN - GRY</td> <td>(When fan revolved one time) 0 V → 5 V → 0 V (Approx.)</td> </tr> </tbody> </table>	Color of lead wire	Normal range	BRN - YLW	4.5 ~ 5.5 V	BRN - GRY	(When fan revolved one time) 0 V → 5 V → 0 V (Approx.)							
Color of lead wire	Normal range												
BRN - YLW	4.5 ~ 5.5 V												
BRN - GRY	(When fan revolved one time) 0 V → 5 V → 0 V (Approx.)												
Indoor fan motor (MF) MSZ-HC35	Check 10-6.Ⓐ.												
Vane motor (MV)	Measure the resistance between the terminals with a tester. (Part temperature 10 ~ 30°C) <table border="1" style="margin-left: 20px;"> <thead> <tr> <th>Color of the lead wire</th> <th>Normal</th> </tr> </thead> <tbody> <tr> <td>RED - BLK</td> <td>235 ~ 255 Ω</td> </tr> </tbody> </table>	Color of the lead wire	Normal	RED - BLK	235 ~ 255 Ω								
Color of the lead wire	Normal												
RED - BLK	235 ~ 255 Ω												

10-6. TROUBLESHOOTING FLOW

Ⓐ Check of indoor fan motor

MSZ-HC25VA

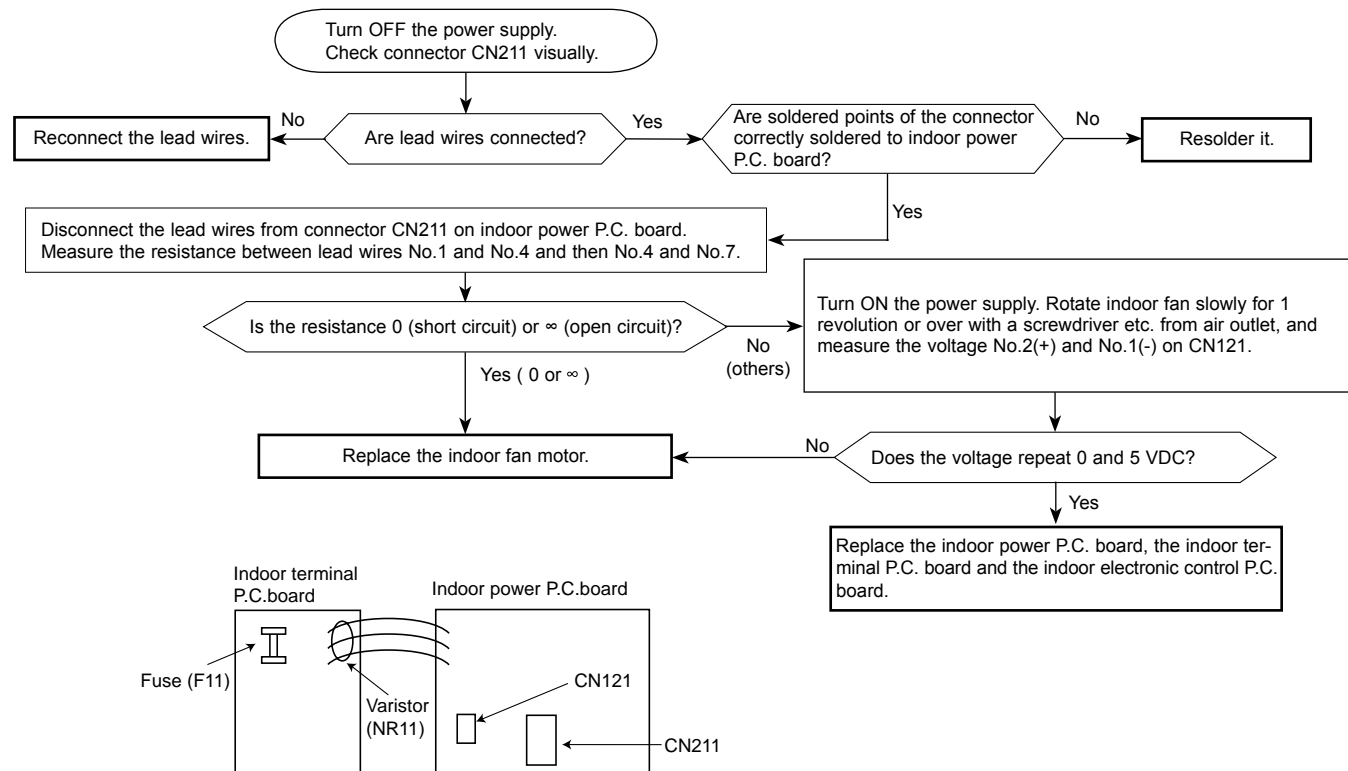

MSZ-HC35VA MSZ-HC35VAB

The indoor fan motor error has occurred, and the indoor fan doesn't operate.

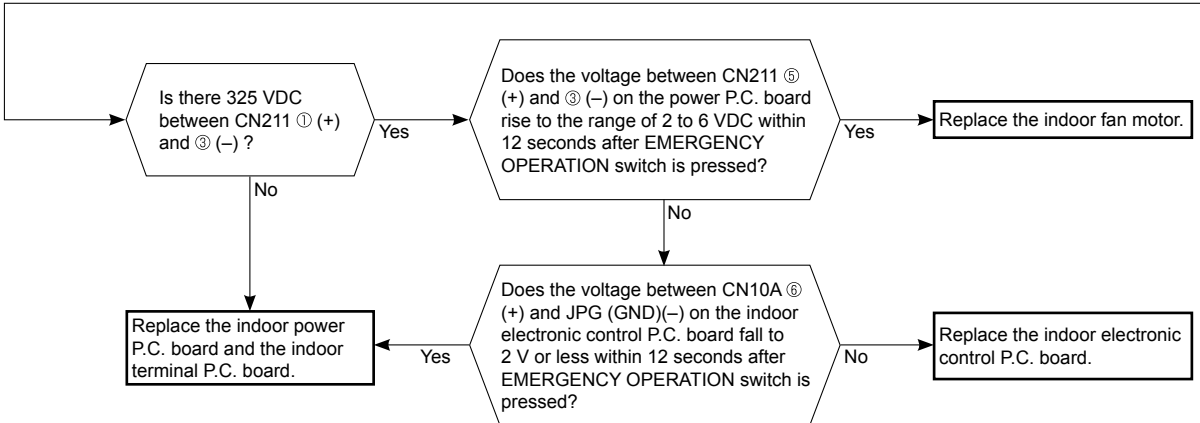
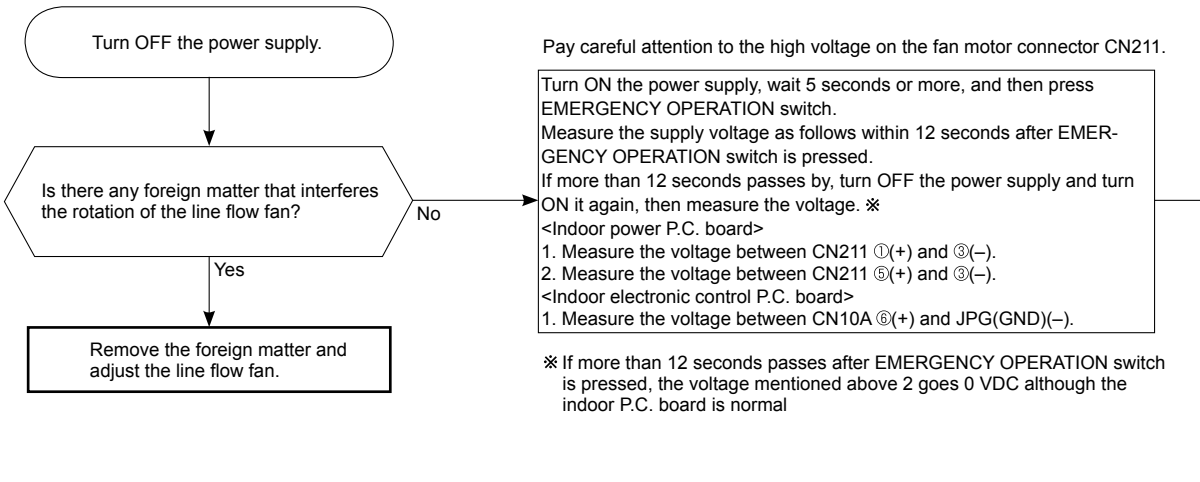

The indoor fan motor error has occurred, and the indoor fan repeats "12-second ON and 30-second OFF" 3 times, and then stops.

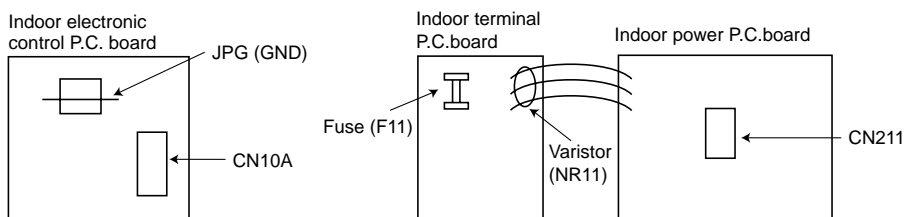
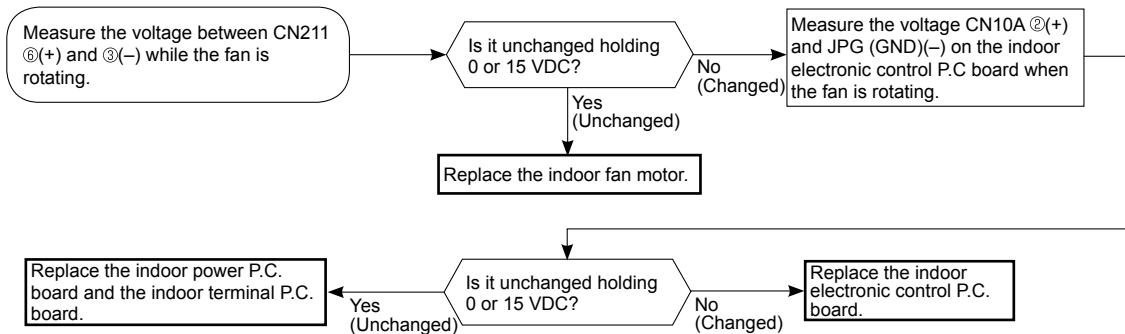

B Check of remote controller and indoor electronic control P.C. board

*Check if the remote controller is exclusive for this air conditioner.

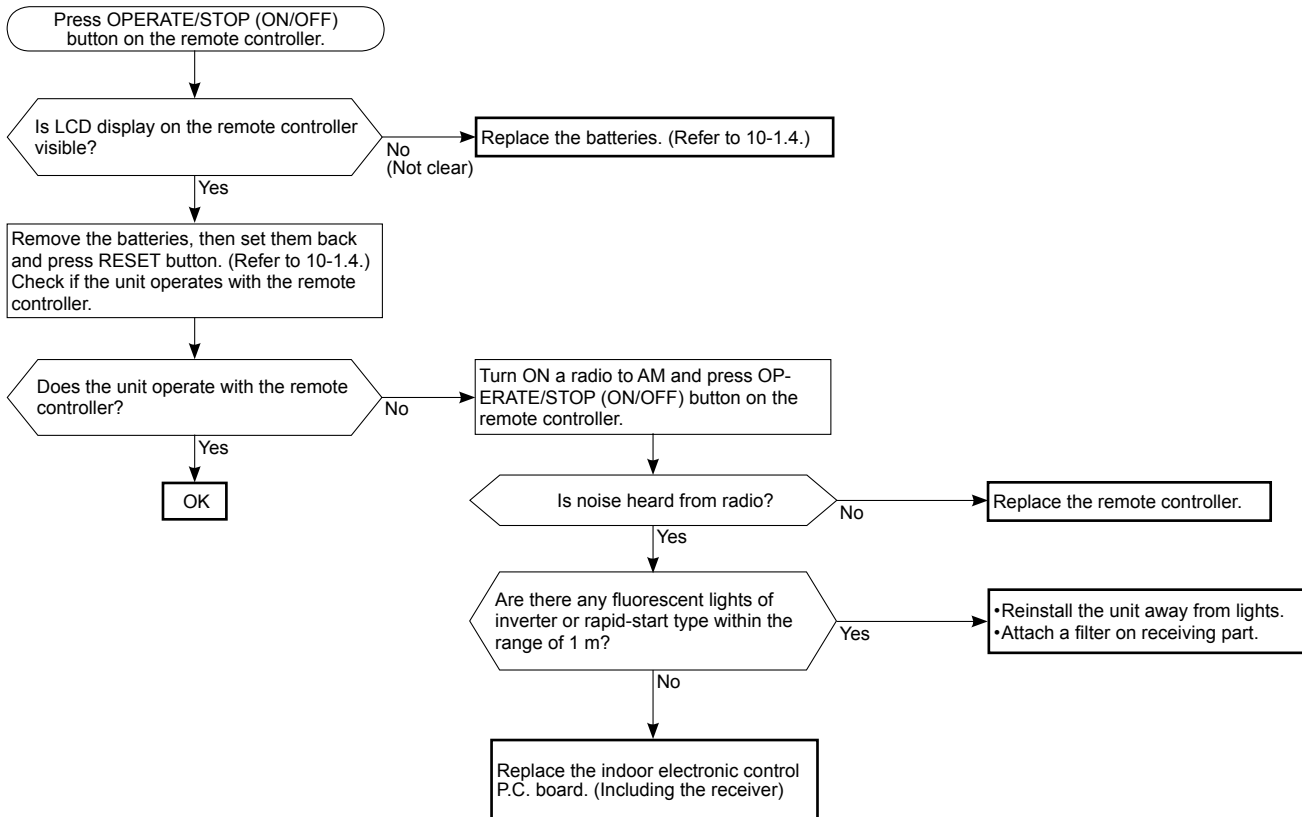

C Check of indoor P.C. board and indoor fan motor

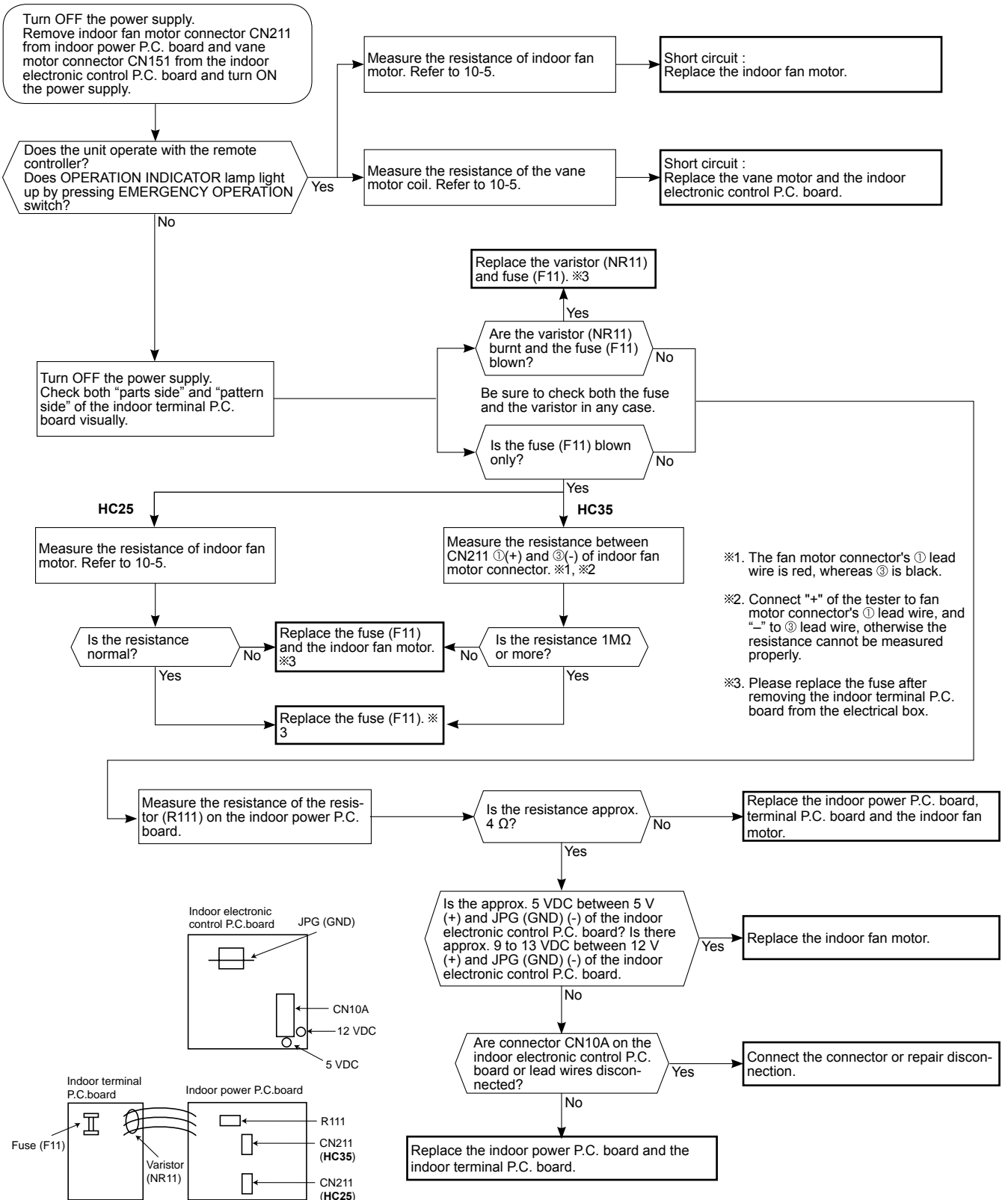

D How to check miswiring and serial signal error

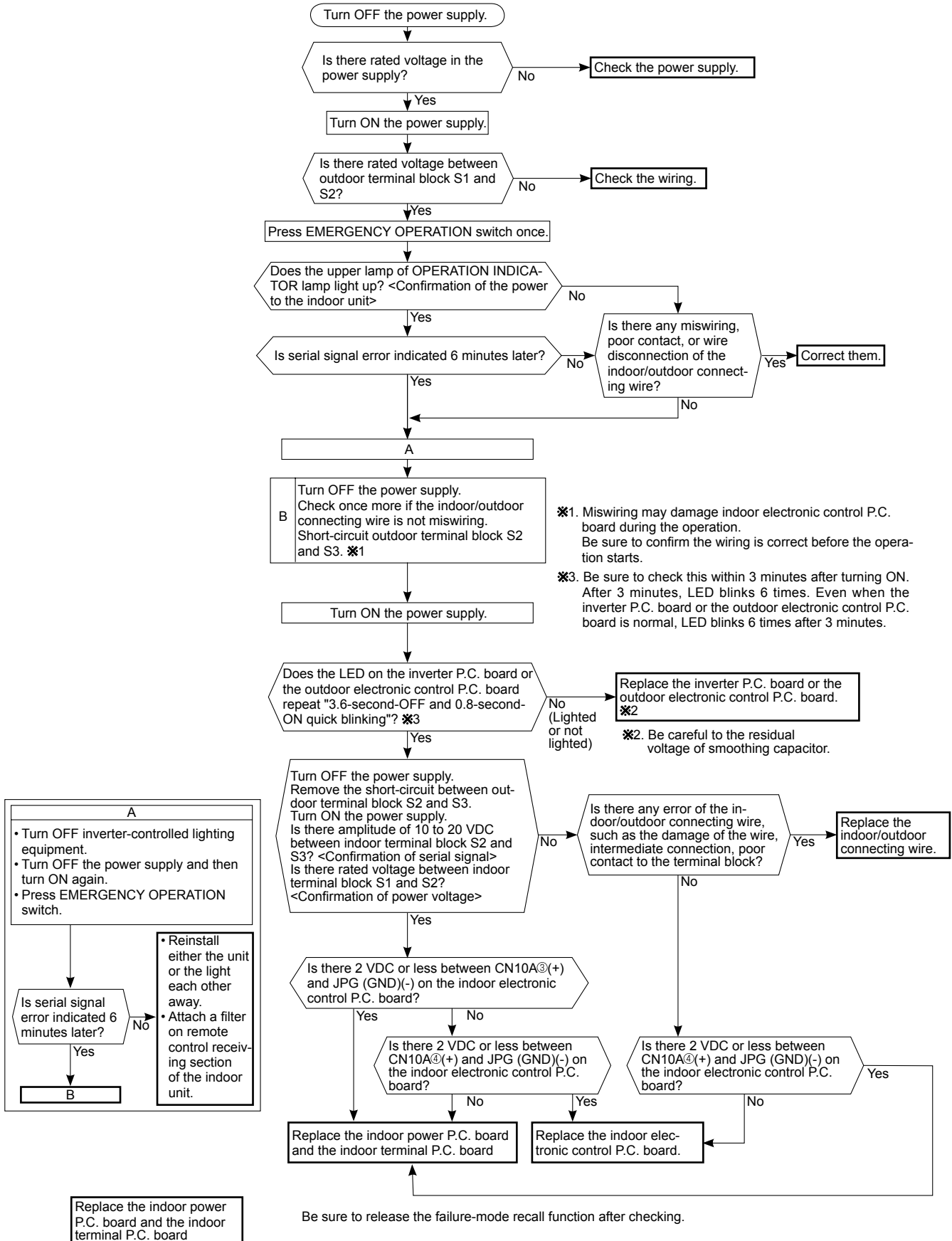

E Electromagnetic noise enters into TV sets or radios

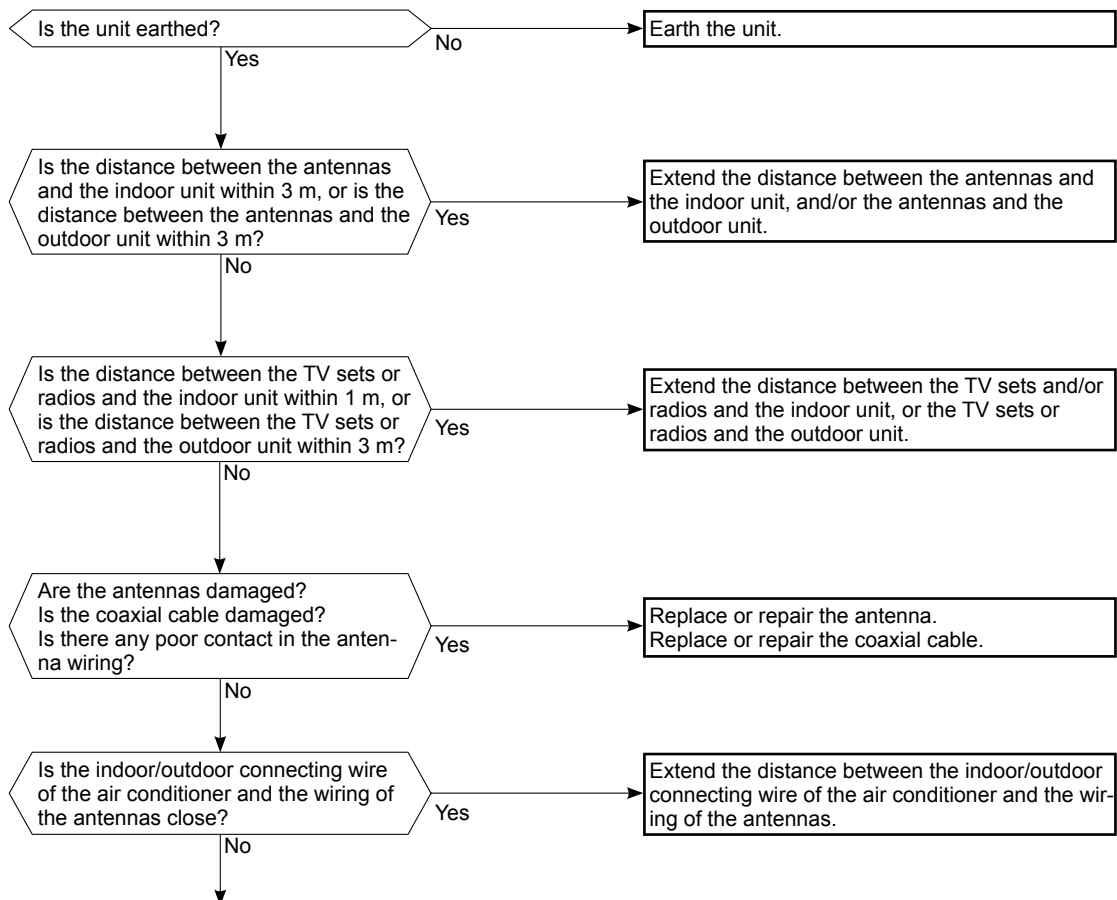

Even if all of the above conditions are fulfilled, the electromagnetic noise may enter, depending on the electric field strength or the installation condition (combination of specific conditions such as antennas or wiring).
Check the following before asking for service.

1. Devices affected by the electromagnetic noise
TV sets, radios (FM/AM broadcast, shortwave)
2. Channel, frequency, broadcast station affected by the electromagnetic noise
3. Channel, frequency, broadcast station unaffected by the electromagnetic noise
4. Layout of ;
indoor/outdoor unit of the air conditioner, indoor/outdoor wiring, earth wire, antennas, wiring from antennas, receiver
5. Electric field intensity of the broadcast station affected by the electromagnetic noise
6. Presence or absence of amplifier such as booster
7. Operation condition of air conditioner when the electromagnetic noise enters in
 - 1) Turn OFF the power supply once, and then turn ON the power supply. In this situation, check for the electromagnetic noise.
 - 2) Within 3 minutes after turning ON the power supply, press OPERATE/STOP (ON/OFF) button on the remote controller for power ON, and check for the electromagnetic noise.
 - 3) After a short time (3 minutes later after turning ON), the outdoor unit starts running. During operation, check for the electromagnetic noise.
 - 4) Press OPERATE/STOP (ON/OFF) button on the remote controller for power OFF, when the outdoor unit stops but the indoor/outdoor communication still runs on. In this situation, check for the electromagnetic noise.

10-7. TEST POINT DIAGRAM AND VOLTAGE

1. Indoor power P.C. board, Indoor terminal P.C. board MSZ-HC25VA

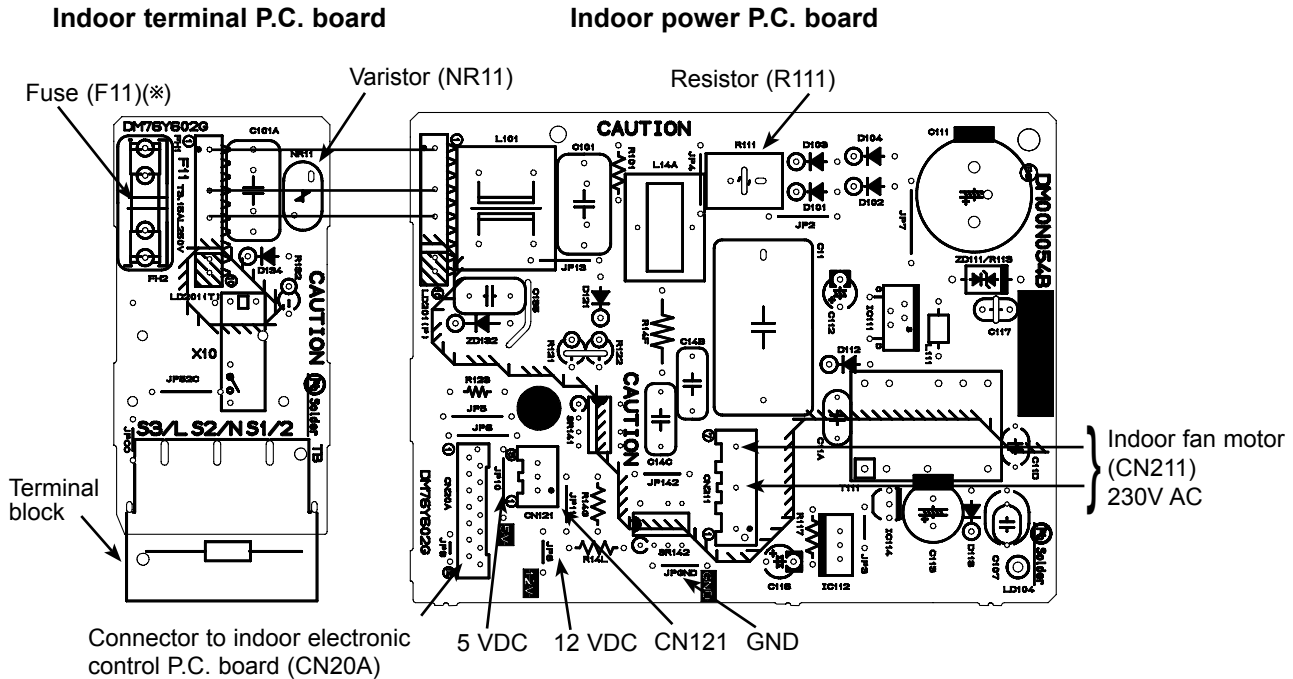

* Please replace the fuse after removing the indoor terminal P.C. board from the electrical box.

MSZ-HC35VA MSZ-HC35VAB

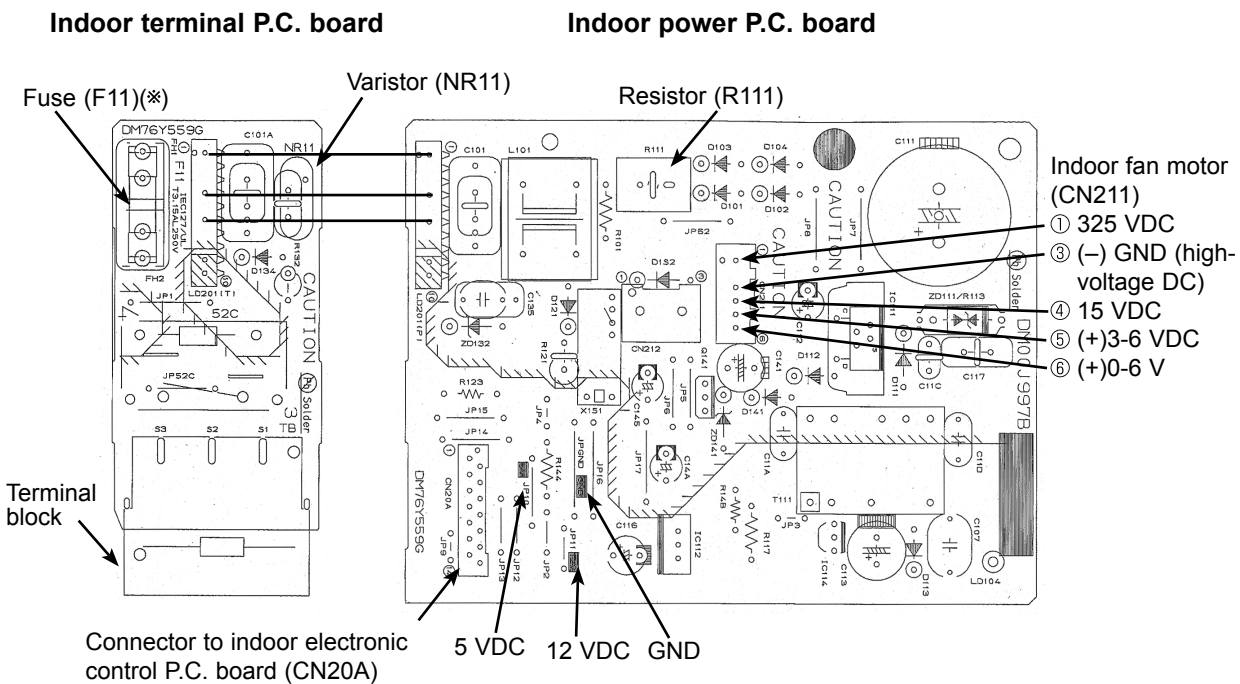

* Please replace the fuse after removing the indoor terminal P.C. board from the electrical box.

2. Indoor electronic control P.C. board

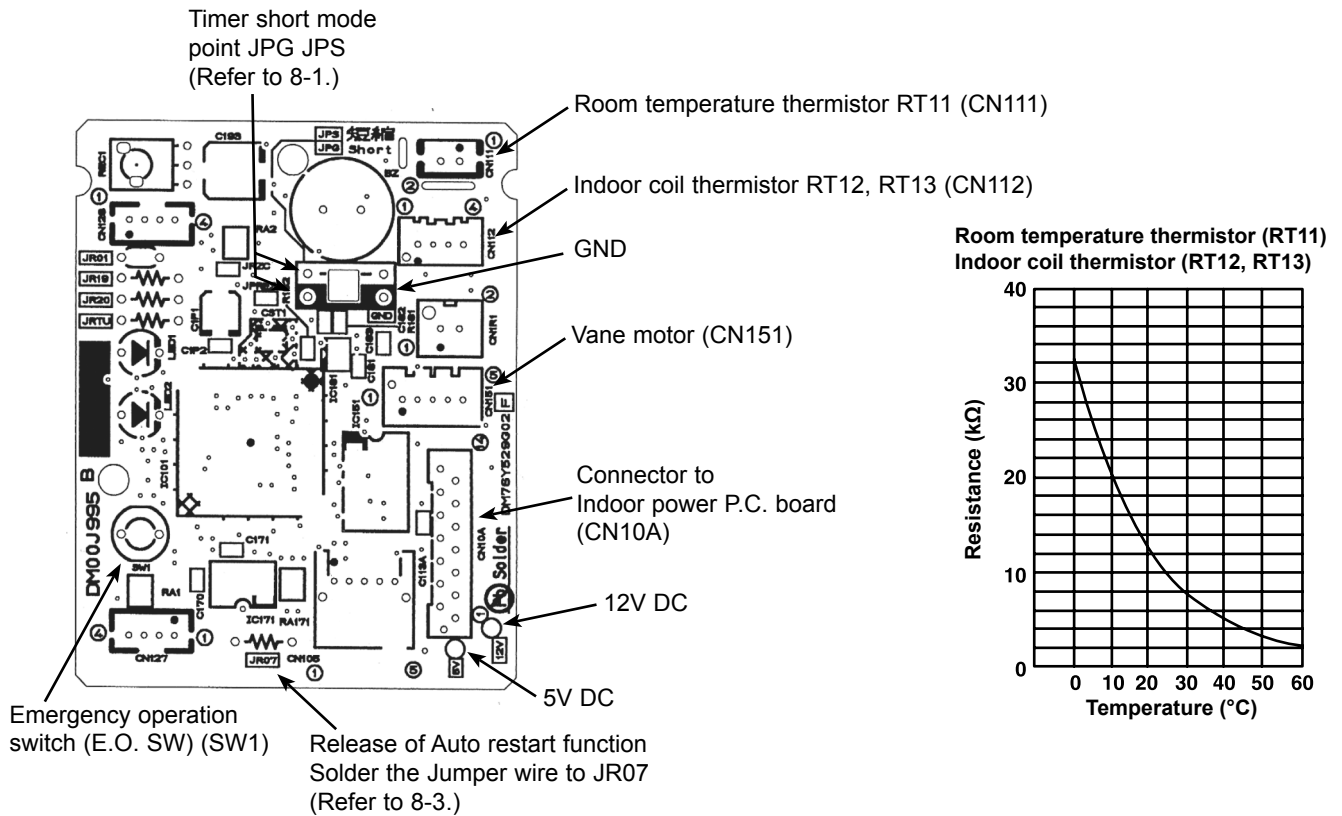

11

DISASSEMBLY INSTRUCTIONS

<"Terminal with locking mechanism" Detaching points>

The terminal which has the locking mechanism can be detached as shown below. There are two types (refer to (1) and (2)) of the terminal with locking mechanism. The terminal without locking mechanism can be detached by pulling it out. Check the shape of the terminal before detaching.

(1) Slide the sleeve and check if there is a locking lever or not.

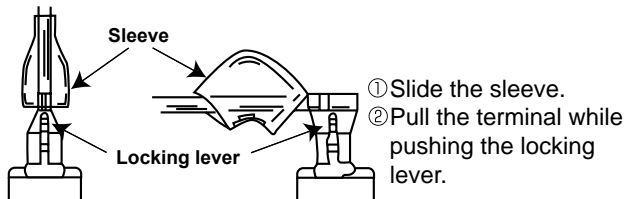

(2) The terminal with this connector has the locking mechanism.

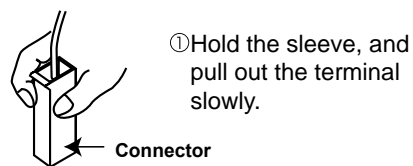

MSZ-HC25VA MSZ-HC35VA MSZ-HC35VAB

OPERATING PROCEDURE

1. Removing the panel

- (1) Remove the screw caps of the panel. Remove the screws.
- (2) Hold the lower ends part of the panel and pull it slightly toward you, and then remove the panel by pushing it upward.

PHOTOS

Photo 1

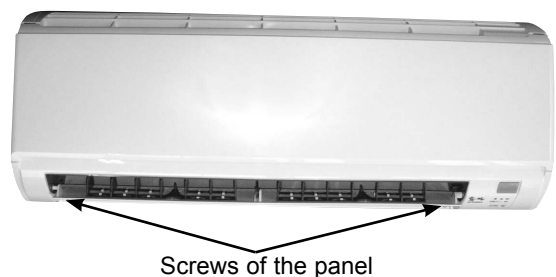

OPERATING PROCEDURE

2. Removing the indoor electronic control P.C. board and the room temperature thermistor

- (1) Turn the breaker OFF.
- (2) Remove the panel (refer to 1.) and the corner box.
- (3) Open the indoor electronic control P.C. board holder (to right side), and disconnect connectors of the indoor coil thermistor (CN112), vane motor (CN151), and connector (CN10A) to the indoor power P.C. board on the indoor electronic control P.C. board.
- (4) Unhook the catches of the indoor electronic control P.C. board holder from the nozzle and the electrical box (right side).
- (5) Remove the room temperature thermistor from the hook of the indoor electronic control P.C. board holder.
- (6) Open the back side of the indoor electronic control P.C. board holder, and remove the indoor electronic control P.C. board.
- (7) Remove the room temperature thermistor from the indoor electronic control P.C. board.

3. Removing the indoor power P.C. board, the indoor terminal P.C. board, and the electrical box

- (1) Turn the breaker OFF.
- (2) Remove the panel (refer to 1.) and the corner box.
- (3) Remove the screw of V.A. clamp, and then the indoor/outdoor connecting wire.
- (4) Remove the earth wire connected to the indoor heat exchanger from the electrical box.
- (5) Unhook first the lower, then the upper catches of the electrical box, and pull out the electrical box.
- (6) Remove the screw of the electrical cover and remove the electrical cover.
- (7) Disconnect all the connectors on the indoor power P.C. board and unhook all lead wires.
- (8) Remove the screw of terminal block on the indoor terminal P.C. board.
- (9) Remove the indoor power P.C. board and the indoor terminal P.C. board.

PHOTOS

Photo 2

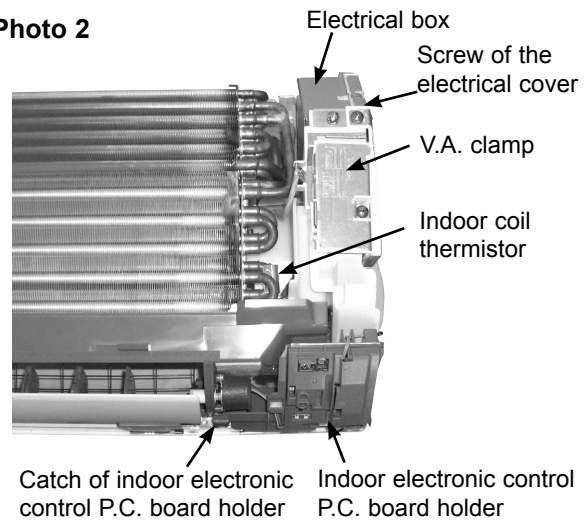

Photo 3

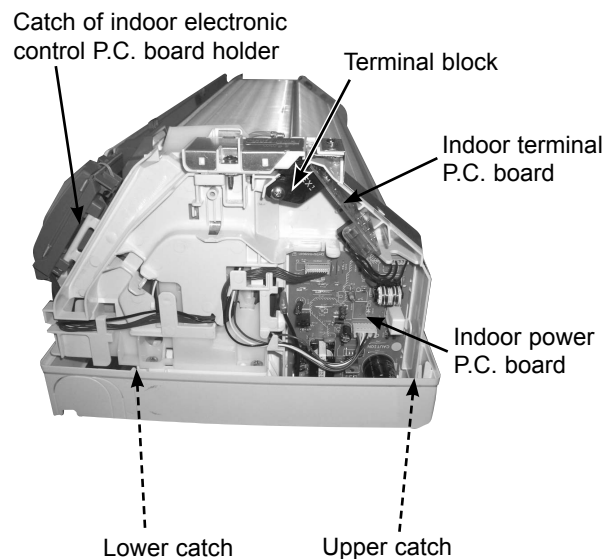

Photo:MSZ-HC35

OPERATING PROCEDURE

4. Removing the vane motor

- (1) Turn the breaker OFF.
- (2) Remove the panel (refer to 1.) and the corner box.
- (3) Remove the indoor electronic control P.C. board holder (refer to 2.).
- (4) Remove the screws of vane motor and remove the vane motor.
- (5) Disconnect the connector from vane motor.

5. Removing the indoor fan motor, the indoor coil thermistor, and the line flow fan

- (1) Remove the panel (refer to 1.) and the corner box.
- (2) Remove the indoor electronic control P.C. board holder (refer to 2.) and the electrical box (refer to 3.).
- (3) Remove the drain hose from the nozzle assembly, and remove the nozzle assembly.
- (4) Loosen the screw fixing the line flow fan.
- (5) Remove the screws fixing the motor bed. Lift the right side of motor bed a little, and pull right to remove the fan motor together with motor band/bed.
- (6) Remove the indoor coil thermistor from the heat exchanger
- (*) **MSZ-HC35VA(B)-E2**
Install the indoor coil thermistor in its former position when assembling it. (Photo 7)
- (7) Remove the screws fixing the left side of the heat exchanger.
- (8) Lift the left side of the heat exchanger, and pull out the line flow fan to the lower-left.

Photo 7

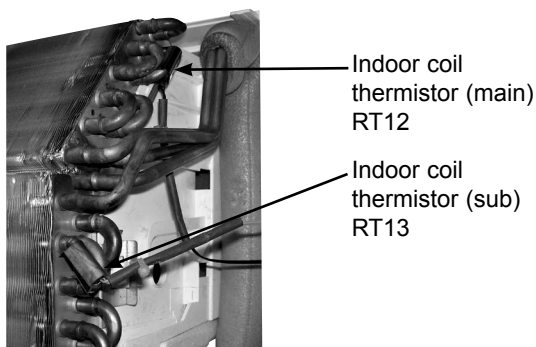

PHOTOS

Photo 4

Screws of the vane motor

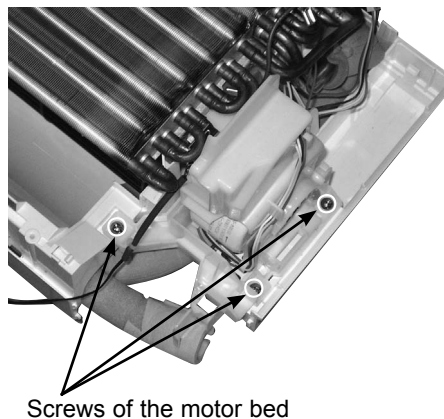

Photo 5



Screws of the line flow fan

Photo 6





HEAD OFFICE: TOKYO BLDG., 2-7-3, MARUNOUCHI, CHIYODA-KU, TOKYO 100-8310, JAPAN

© Copyright 2007 MITSUBISHI ELECTRIC ENGINEERING CO.,LTD

Distributed in Aug. 2008. No. OBH466 REVISED EDITION-B 6

Distributed in Feb. 2007. No. OBH466 REVISED EDITION-A 6

Distributed in Jan. 2007. No. OBH466 6

Made in Japan

New publication, effective Aug. 2008
Specifications subject to change without notice.