

**Revision C:**

- The compressor winding resistance for MUZ-GE71VA - **E1** has been changed.

Please void OBH516 REVISED EDITION-B.

# OUTDOOR UNIT SERVICE MANUAL



**No. OBH516  
REVISED EDITION-C**

## Models

**MUZ-GE25VA - **E1****      **MUZ-GE50VA - **E1****  
**MUZ-GE25VAH - **E1****      **MUZ-GE50VAH - **E1****  
**MUZ-GE35VA - **E1****      **MUZ-GE60VA - **E1****  
**MUZ-GE35VAH - **E1****      **MUZ-GE71VA - **E1****  
**MUZ-GE42VA - **E1****  
**MUZ-GE42VAH - **E1****

Indoor unit service manual  
MSZ-GE•VA Series (OBH515)  
MSZ-CGE•VA Series (OBH523)

MUZ-GE25VA  
MUZ-GE35VA  
MUZ-GE42VA

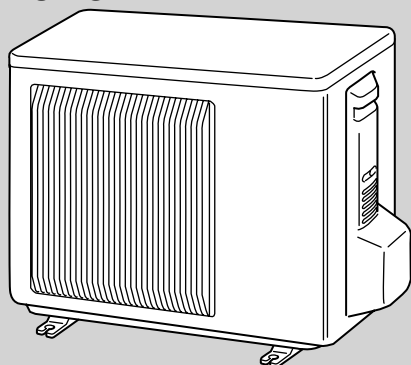

## CONTENTS

1. TECHNICAL CHANGES .....	3
2. PART NAMES AND FUNCTIONS.....	4
3. SPECIFICATION.....	5
4. NOISE CRITERIA CURVES .....	7
5. OUTLINES AND DIMENSIONS .....	9
6. WIRING DIAGRAM.....	11
7. REFRIGERANT SYSTEM DIAGRAM .....	18
8. PERFORMANCE CURVES.....	21
9. ACTUATOR CONTROL.....	40
10. SERVICE FUNCTIONS.....	41
11. TROUBLESHOOTING .....	41
12. DISASSEMBLY INSTRUCTIONS.....	61

**PARTS CATALOG (OBB516)**

**NOTE:**  
RoHS compliant products have <G> mark on the spec name plate.



**Revision A:**

- MUZ-GE42VA - [E1], MUZ-GE42VAH - [E1], MUZ-GE50VA - [E1] and MUZ-GE50VAH - [E1] have been added.

**Revision B:**

- MUZ-GE60VA - [E1] and MUZ-GE71VA - [E1] have been added.

**Revision C:**

- The compressor winding resistance for MUZ-GE71VA - [E1] has been changed.

**MUZ-GE25VA -E1****MUZ-GE25VAH -E1****MUZ-GE35VA -E1****MUZ-GE35VAH -E1****MUZ-GE42VA -E1****MUZ-GE42VAH -E1****MUZ-GE50VA -E1****MUZ-GE50VAH -E1****MUZ-GE60VA -E1****MUZ-GE71VA -E1**

1. New model

# 2

# PART NAMES AND FUNCTIONS

MUZ-GE25VA MUZ-GE25VAH MUZ-GE35VA MUZ-GE35VAH  
 MUZ-GE42VA MUZ-GE42VAH

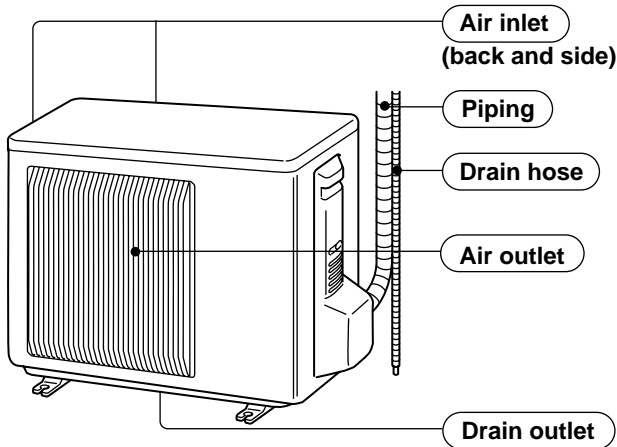

MUZ-GE50VA MUZ-GE50VAH

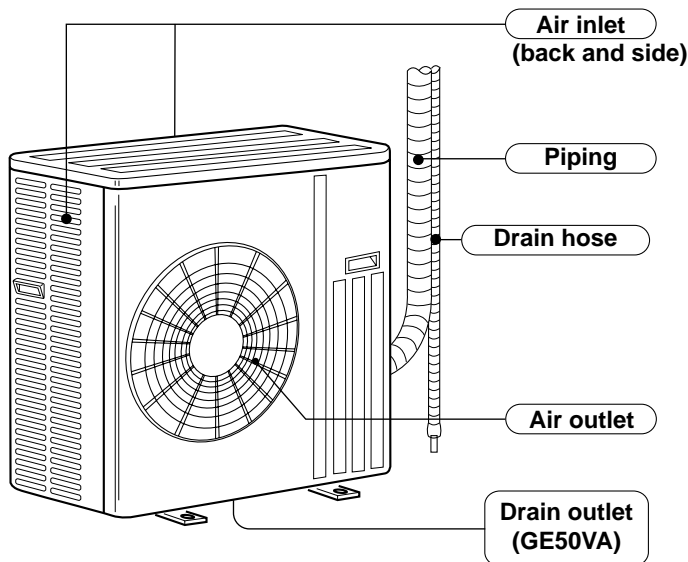

MUZ-GE60VA MUZ-GE71VA

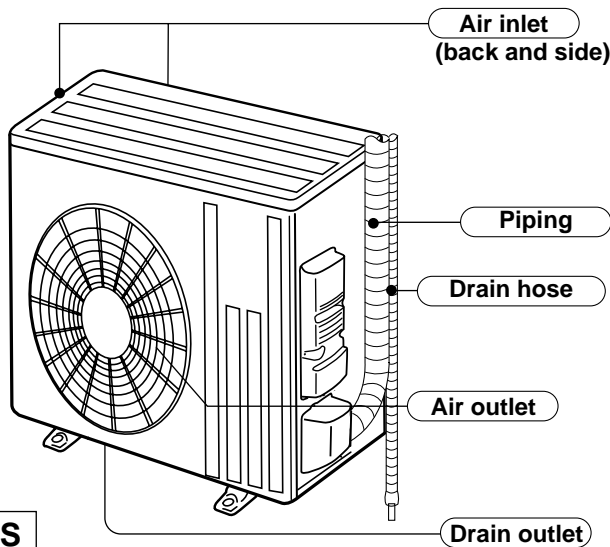

## ACCESSORIES

	Model	MUZ-GE25/35/42VA	MUZ-GE50VA	MUZ-GE60/71VA
①	Drain socket	1	1	1
②	Drain cap	-	2	-

# 3

# SPECIFICATION

Outdoor model			MUZ-GE25VA MUZ-GE25VAH	MUZ-GE35VA MUZ-GE35VAH	MUZ-GE42VA MUZ-GE42VAH	MUZ-GE50VA MUZ-GE50VAH	MUZ-GE60VA	MUZ-GE71VA		
Power supply			Single phase, 230 V, 50 Hz							
Capacity Rated frequency (Min.-Max.)	Cooling	kW	2.5 (1.1 - 3.5)	3.5 (1.1 - 4.0)	4.2 (0.9 - 4.8)	5.0 (1.4 - 5.5)	6.0 (1.5 - 7.5)	7.1 (2.4 - 8.7)		
	Heating		3.2 (1.3 - 4.5)	4.0 (1.6 - 5.3)	5.4 (1.4 - 6.0)	5.8 (1.4 - 7.3)	6.8 (2.0 - 9.3)	8.1 (2.2 - 9.9)		
Breaker Capacity		A	10			16	20			
Electrical data	Power input *1 (Total)	Cooling	545	865	1,215	1,515	1,760	2,130		
		Heating	700	955	1,460	1,565	1,770	2,110		
	Running current *1 (Total)	Cooling	2.9	4.2	5.6	6.8	7.8	9.3		
		Heating	3.7	4.6	6.6	7.0	7.9	9.4		
	Power factor *1 (Total)	Cooling	82	90	94	96	98	99		
Heating		82	90	96	97		98			
Starting current *1 (Total)		A	3.7	4.6	6.6	7.0	7.9	9.4		
Coefficient of performance (COP) *1 (Total)		Cooling	4.59	4.05	3.46	3.30	3.40	3.33		
		Heating	4.57	4.19	3.70	3.71	3.84	3.83		
Compressor			Model	KNB073FFDHC	KNB092FFAHC	SNB130FGBHT	SNB130FGBMT	SNB172FEKMT		
			Output	W	550	650	900		1,200	
Current *1			Cooling	A	2.44	3.56	4.99	6.09	6.59	8.00
					Heating	3.20	4.06	5.98	6.32	6.44
Refrigeration oil (Model)			cc	320 (NEO22)		450 (NEO22)	350(FV50S)	400(FV50S)		
Fan motor			Model	RC0J50-DB		RC0J50-EA	RC0J60-AA	RC0J60-BC		
			Current *1	Cooling	0.24	0.35	0.32		0.84	0.83
Heating		A		0.27	0.31		0.32	0.93	0.82	
Dimensions W × H × D			mm	800 × 550 × 285			840 × 850 × 330	840 × 880 × 330		
Weight			kg	30	33	36	54	50	53	
Special remarks	Dehumidification		Cooling	ℓ/h	0.2	0.9	1.4	1.8		2.3
	Air flow *1	Cooling	High	m <sup>3</sup> /h	-			3,492		3,426
			Med.		1,806	1,872		2,940	3,066	3,006
			Low		1,170	1,776	1,086	1,740	1,692	1,512
		Heating	High		2,106	2,016		-	2,952	2,892
			Med.		1,806	1,776		2,940	2,952	2,892
			Low		1,452	1,386		2,142	2,226	2,280
	Sound level *1		Cooling	dB(A)	47		50	54	55	
			Heating		48		51	56	55	
	Fan speed	Cooling	High	rpm	-			950		
			Med.		740	810		780	840	
			Low		490	770	490	480		450
		Heating	High		860	870		-	810	
			Med.		740	770		780	810	
			Low		600	610		580	620	650
Fan speed regulator				3			2	3		
Refrigerant filling capacity (R410A)			kg	0.80	1.15		1.55		1.90	

**NOTE:** Test conditions are based on ISO 5151.

Cooling: Indoor Dry-bulb temperature 27°C  
 Outdoor Dry-bulb temperature 35°C  
 Heating: Indoor Dry-bulb temperature 20°C  
 Outdoor Dry-bulb temperature 7°C

Wet-bulb temperature 19°C

Wet-bulb temperature 6°C

Refrigerant piping length (one way): 5 m

\*1 Measured under rated operating frequency.

**Specifications and rating conditions of main electric parts**

Model		MUZ-GE25VA	MUZ-GE25VAH	MUZ-GE35VA	MUZ-GE35VAH	MUZ-GE42VA	MUZ-GE42VAH	MUZ-GE50VA	MUZ-GE50VAH	MUZ-GE60VA	MUZ-GE71VA	
Current transformer	(CT)	20 A									—	
Smoothing capacitor	(C61, C62, C63)	620 $\mu$ F 420 V									—	
	(CB1, CB2, CB3)	—									560 $\mu$ F 450 V	
Diode module	(DB61)	15 A 600 V					25 A 600 V					—
	(DB65)	25 A 600 V									—	
Fuse	(F62)	—									T2.0AL250 V	
	(F61)	T20AL250V									—	
	(F701, F801, F901)	T3.15AL250V									—	
	(F601, F880, F901)	—									T3.15AL250 V	
Defrost heater	(H)	—	230 V 130 W	—	230 V 130 W	—	230 V 130 W	—	230 V 120 W	—		
Intelligent power module	(IC932)	—									5 A 600 V	
	(IPM)	15 A 600 V					20 A 600 V					—
Expansion valve coil	(LEV)	12 V DC									—	
Reactor	(L61)	18 mH			23 mH						—	
	(L)	—									340 $\mu$ H	
Power factor controller	(PFC)	—									20 A 600 V	
Current-detecting resistor	(R61)	45 m $\Omega$ 5 W (1 element)		100 m $\Omega$ 5 W (2 elements)		—					—	
	(R61,R62)	—				180 m $\Omega$ 5 W (2 elements)				—		
	(R825)	25 m $\Omega$ 5 W									—	
	(R937, R938, R939)	430 m $\Omega$ 2 W						—				
	(R937A,R937B)	—						1.1 $\Omega$ 2 W			—	
Current-limiting PTC thermistor	(PTC64, PTC65)	33 $\Omega$									—	
Terminal block	(TB1, TB2)	3 P									—	
Relay	(X63)	3 A 250 V									—	
	(X64)	20 A 250 V									—	
	(X66)	—	3 A 250 V	—	3 A 250 V	—	3 A 250 V	—	3 A 250 V	—		
	(X601)	—									3 A 250 V	
	(X602)	—									3 A 250 V	
R.V.coil	(21S4)	220 - 240 V AC									—	
Heater protector	(26H)	—	Open 45°C	—	Open 45°C	—	Open 45°C	—	Open 45°C	—		
IGBT	(TR821)	30 A 600 V									—	

# 4

# NOISE CRITERIA CURVES

## MUZ-GE25VA MUZ-GE25VAH

FUNCTION	SPL(dB(A))	LINE
COOLING	47	●—●
HEATING	48	○—○

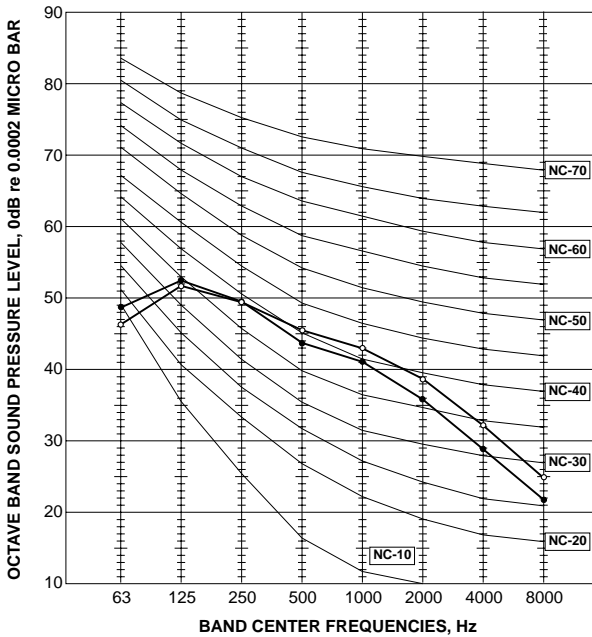

## MUZ-GE35VA MUZ-GE35VAH

FUNCTION	SPL(dB(A))	LINE
COOLING	47	●—●
HEATING	48	○—○

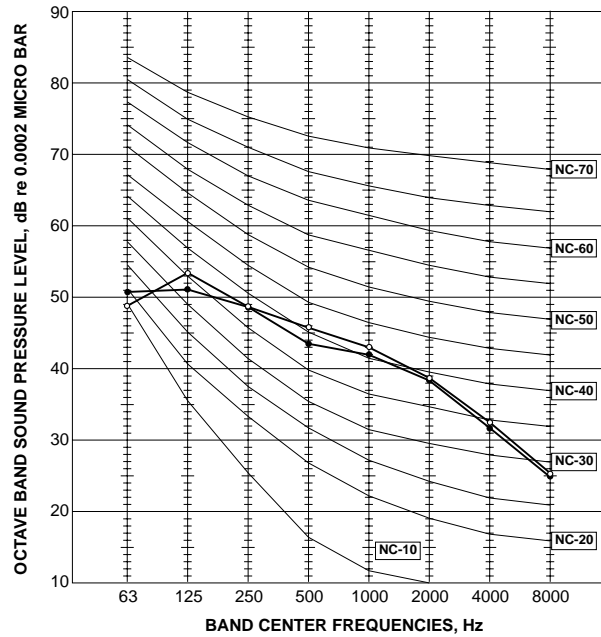

## MUZ-GE42VA MUZ-GE42VAH

FUNCTION	SPL(dB(A))	LINE
COOLING	50	●—●
HEATING	51	○—○

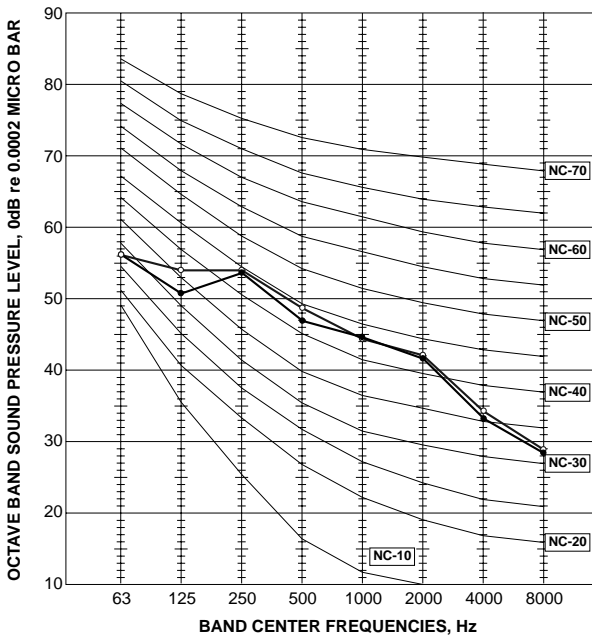

## MUZ-GE50VA MUZ-GE50VAH

FUNCTION	SPL(dB(A))	LINE
COOLING	54	●—●
HEATING	56	○—○

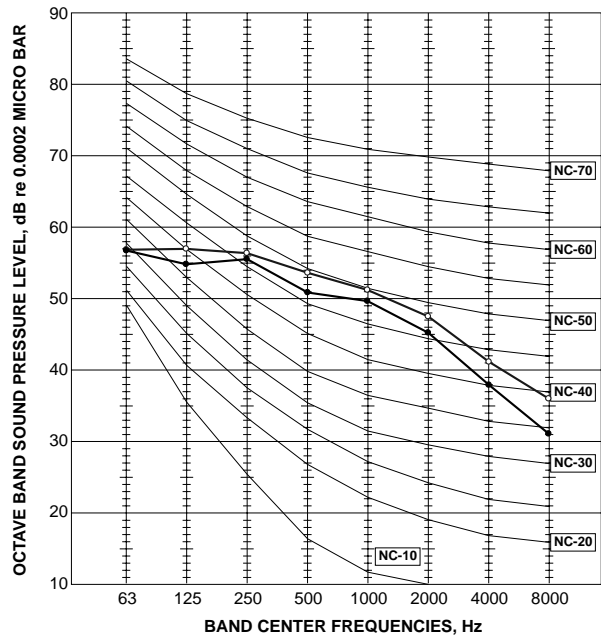

## MUZ-GE60VA

FUNCTION	SPL(dB(A))	LINE
COOLING	55	●—●
HEATING	55	○—○

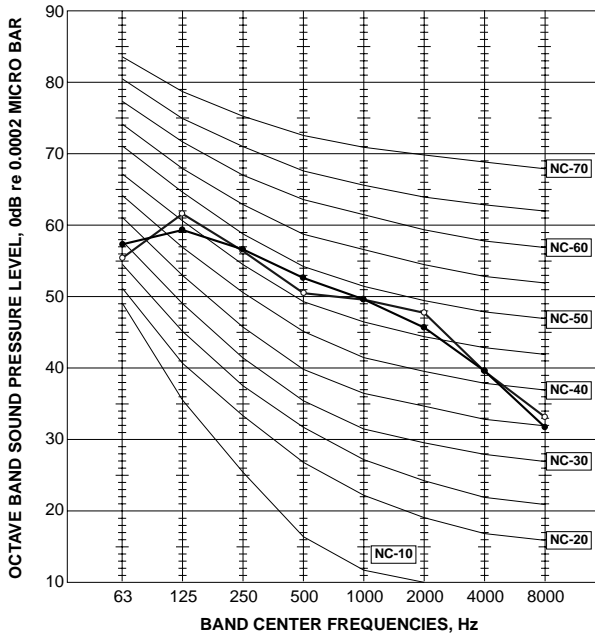

## MUZ-GE71VA

FUNCTION	SPL(dB(A))	LINE
COOLING	55	●—●
HEATING	55	○—○

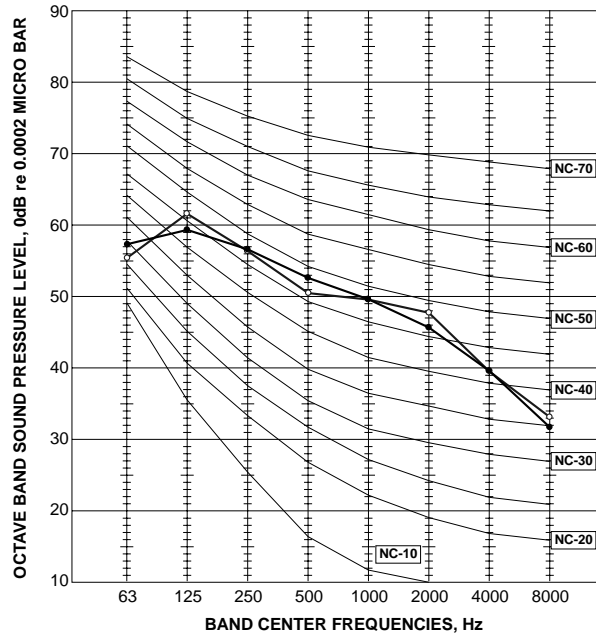

### Test conditions

Cooling: Dry-bulb temperature 35°C

Heating: Dry-bulb temperature 7°C Wet-bulb temperature 6°C

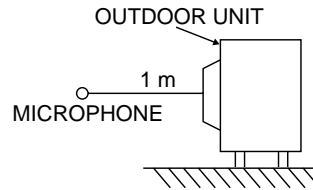



# 5

# OUTLINES AND DIMENSIONS

**MUZ-GE25VA MUZ-GE25VAH MUZ-GE35VA MUZ-GE35VAH  
MUZ-GE42VA MUZ-GE42VAH**

Unit: mm

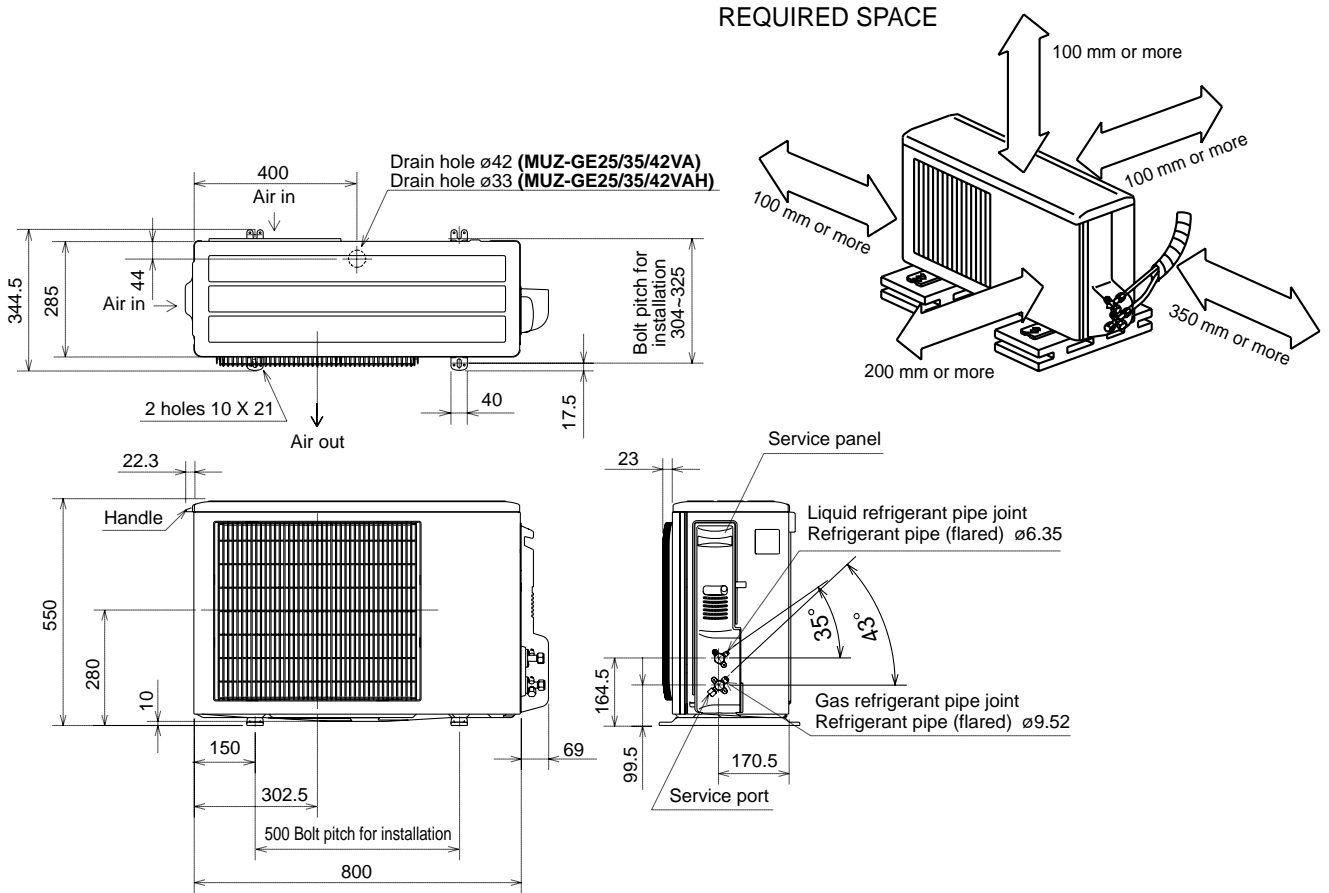

**MUZ-GE50VA MUZ-GE50VAH**

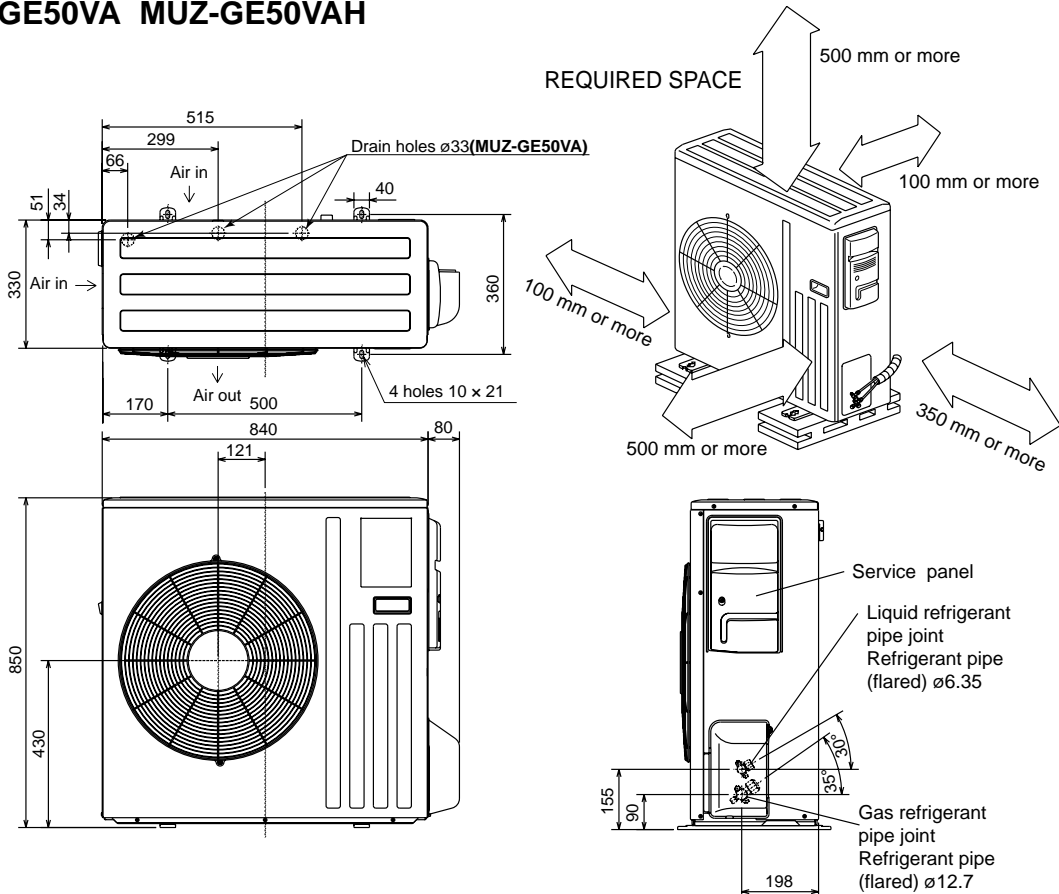

**MUZ-GE60VA MUZ-GE71VA**

Unit: mm

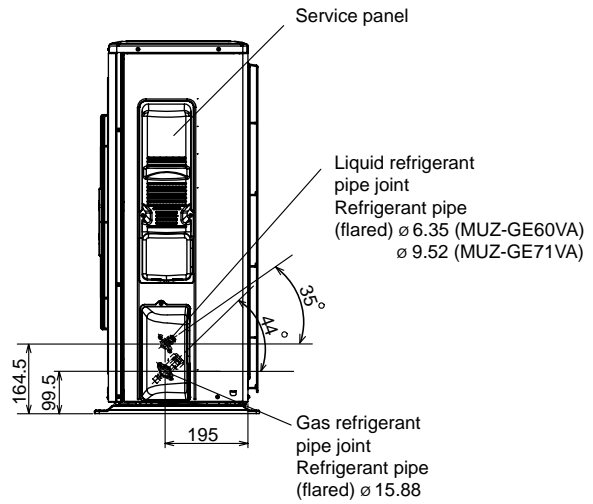
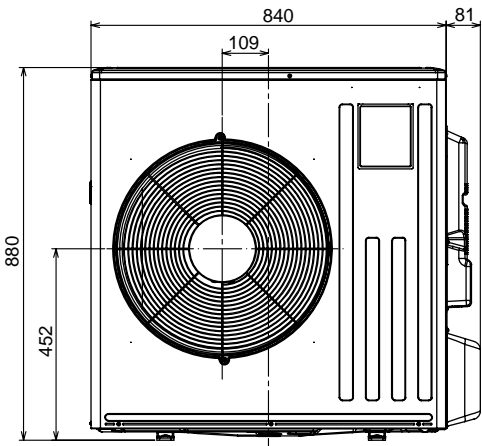
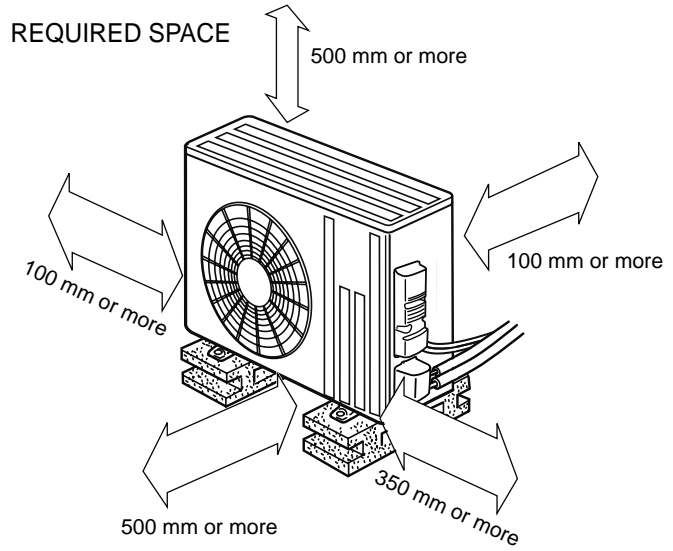
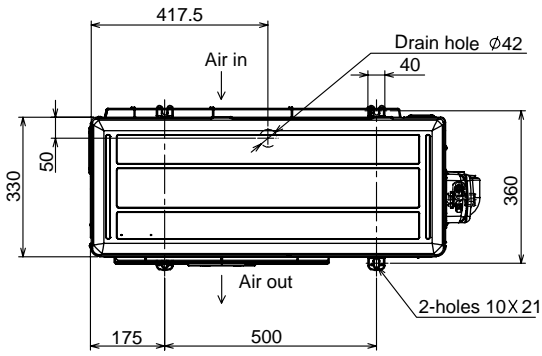

MUZ-GE25VA MUZ-GE35VA

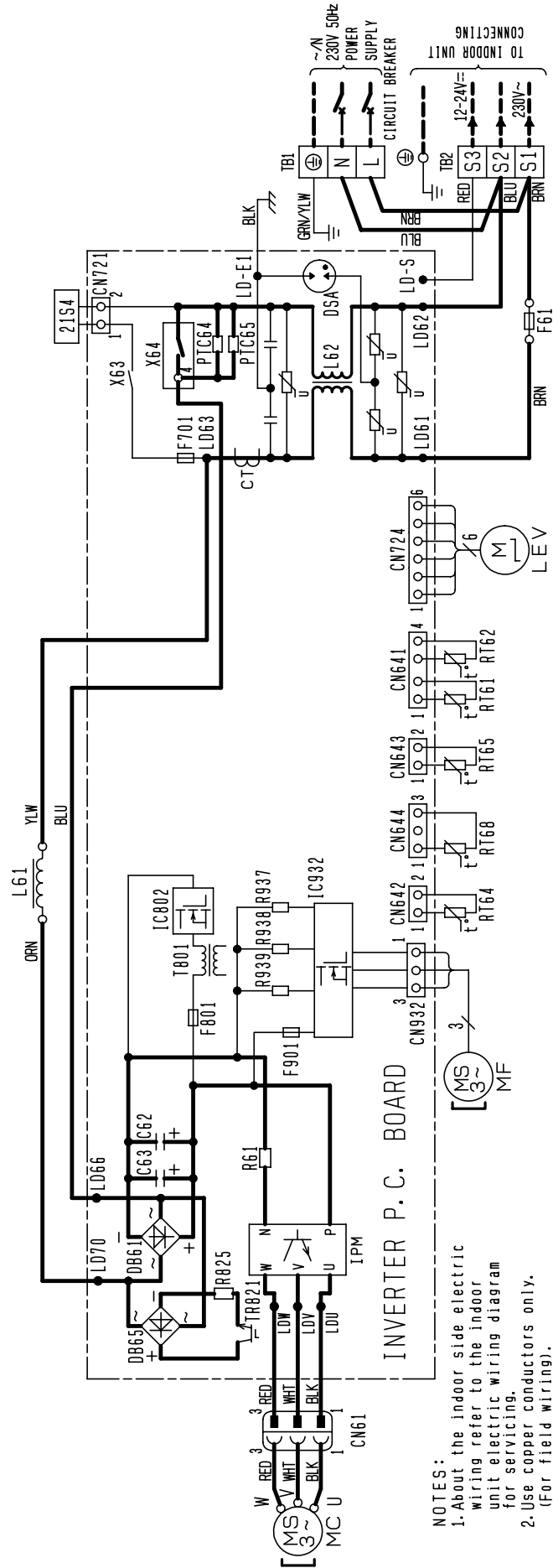

INVERTER P. C. BOARD

- NOTES:
- About the indoor side electric wiring refer to the indoor unit electric wiring diagram for servicing.
  - Use copper conductors only. (For field wiring).

SYMBOL	NAME	SYMBOL	NAME	SYMBOL	NAME
CT	CURRENT TRANSFORMER	LEV	EXPANSION VALVE COIL	R61	CURRENT-DETECTING RESISTOR
C62, C63	SMOOTHING CAPACITOR	MC	COMPRESSOR	R825, R937	CURRENT-DETECTING RESISTOR
DB61, DB65	DIODE MODULE	MF	FAN MOTOR	R938, R939	CURRENT-DETECTING RESISTOR
DSA	SURGE ABSORBER	PTC64, PTC65	CIRCUIT PROTECTION	TB1, TB2	TERMINAL BLOCK
F61	FUSE (T20AL 250V)	RT61	DEFROST THERMISTOR	TR821	SWITCHING POWER TRANSISTOR
F701, F801, F901	FUSE (T3.15AL 250V)	RT62	DISCHARGE TEMP. THERMISTOR	T801	TRANSFORMER
IC802	INTELLIGENT POWER DEVICE	RT64	FIN TEMP. THERMISTOR	X63, X64	RELAY
IPM	INTELLIGENT POWER MODULE	RT65	AMBIENT TEMP. THERMISTOR	21S4	REVERSING VALVE COIL
L61	REACTOR	RT68	OUTDOOR HEAT EXCHANGER TEMP. THERMISTOR.		
L62	CMC COIL				

# MUZ-GE25VAH MUZ-GE35VAH

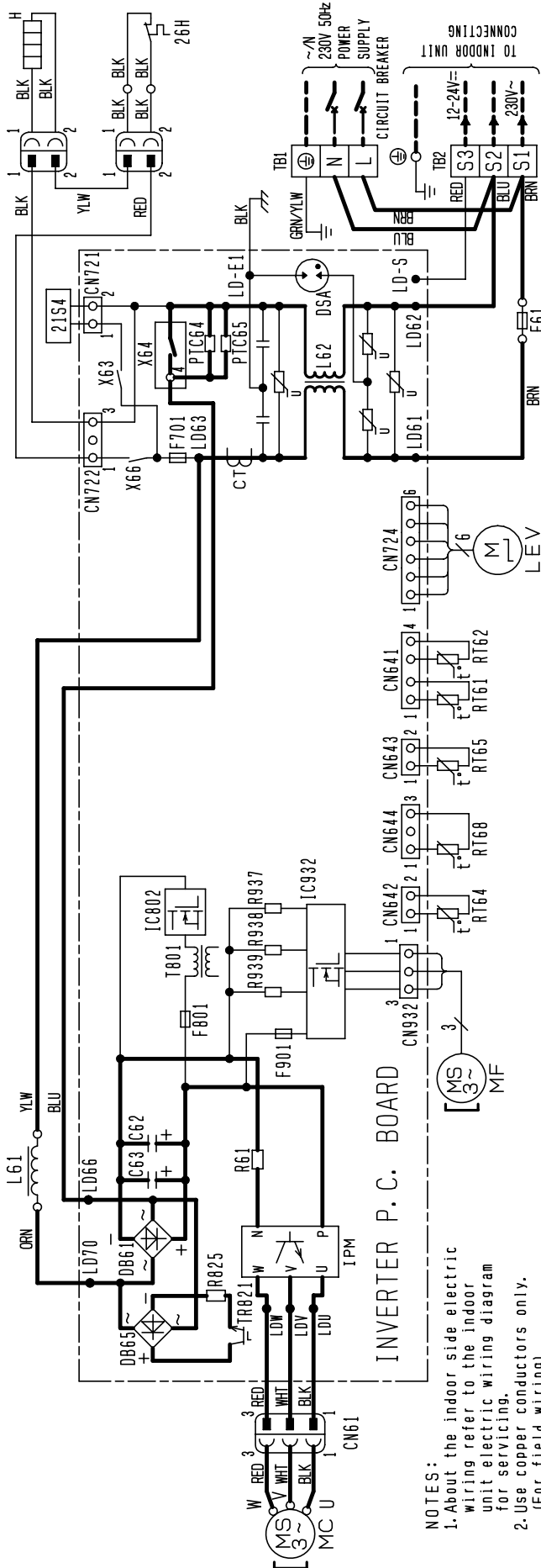

- NOTES:**
- About the indoor side electric wiring refer to the indoor unit electric wiring diagram for servicing.
  - Use copper conductors only. (For field wiring).

SYMBOL	NAME	SYMBOL	NAME	SYMBOL	NAME
CT	CURRENT TRANSFORMER	LEV	EXPANSION VALVE COIL	R61	CURRENT-DETECTING RESISTOR
C62, C63	SMOOTHING CAPACITOR	MC	COMPRESSOR	R825, R937	CURRENT-DETECTING RESISTOR
DB61, DB65	DIODE MODULE	MF	FAN MOTOR	R938, R939	CURRENT-DETECTING RESISTOR
DSA	SURGE ABSORBER	PTC64, PTC65	CIRCUIT PROTECTION	TB1, TB2	TERMINAL BLOCK
F61	FUSE (T20AL250V)	RT61	DEFROST THERMISTOR	TR821	SWITCHING POWER TRANSISTOR
F701, F801, F901	FUSE (T3, 15AL250V)	RT62	DISCHARGE TEMP. THERMISTOR	T801	TRANSFORMER
IC802	INTELLIGENT POWER DEVICE	RT64	F-IN TEMP. THERMISTOR	X63, X64, X66	RELAY
IPM, IC932	INTELLIGENT POWER MODULE	RT65	AMBIENT TEMP. THERMISTOR	21S4	REVERSING VALVE COIL
L61	REACTOR	RT68	OUTDOOR HEAT EXCHANGER TEMP. THERMISTOR.	H	DEFROST HEATER
L62	CMC COIL			26H	HEATER PROTECTOR

# MUZ-GE42VA

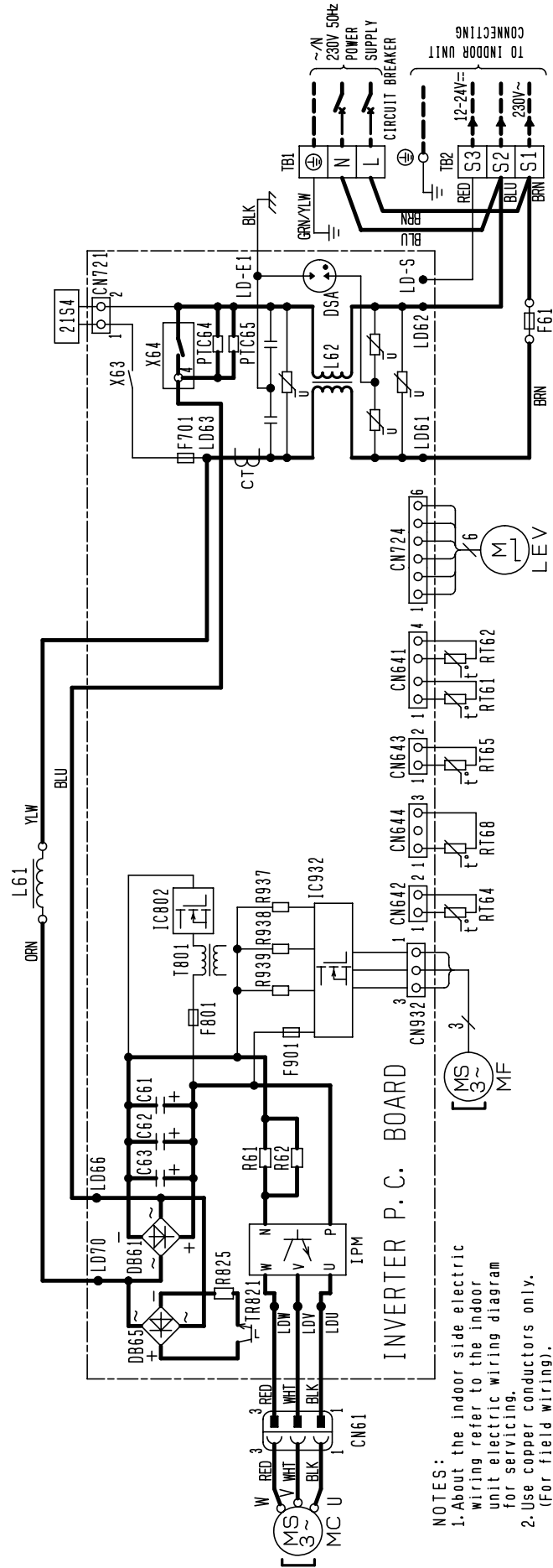

## INVERTER P.C. BOARD

- NOTES:
- About the indoor side electric wiring refer to the indoor unit electric wiring diagram for servicing.
  - Use copper conductors only. (For field wiring).

SYMBOL	NAME	SYMBOL	NAME	SYMBOL	NAME
CT	CURRENT TRANSFORMER	LEV	EXPANSTION VALVE COIL	R61	CURRENT-DETECTING RESISTOR
C61, C62, C63	SMOOTHING CAPACITOR	MC	COMPRESSOR	R62	CURRENT-DETECTING RESISTOR
DB61, DB65	DIODE MODULE	MF	FAN MOTOR	R825, R937	CURRENT-DETECTING RESISTOR
DSA	SURGE ABSORBER	PTC64, PTC65	CIRCUIT PROTECTION	R938, R939	CURRENT-DETECTING RESISTOR
F61	FUSE (T20AL250V)	RT61	DEFROST THERMISTOR	TB1, TB2	TERMINAL BLOCK
F701, F801, F901	FUSE (T3, 15A, 250V)	RT62	DISCHARGE TEMP. THERMISTOR	T8821	SWITCHING POWER TRANSISTOR
IC802	INTELLIGENT POWER DEVICE	RT64	F IN TEMP. THERMISTOR	T801	TRANSFORMER
IPM	INTELLIGENT POWER MODULE	RT65	AMBIENT TEMP. THERMISTOR	X63, X64	RELAY
L61	REACTOR	RT68	OUTDOOR HEAT EXCHANGER TEMP. THERMISTO	21S4	REVERSING VALVE COIL
L62	CMC COIL				

# MUZ-GE42VAH

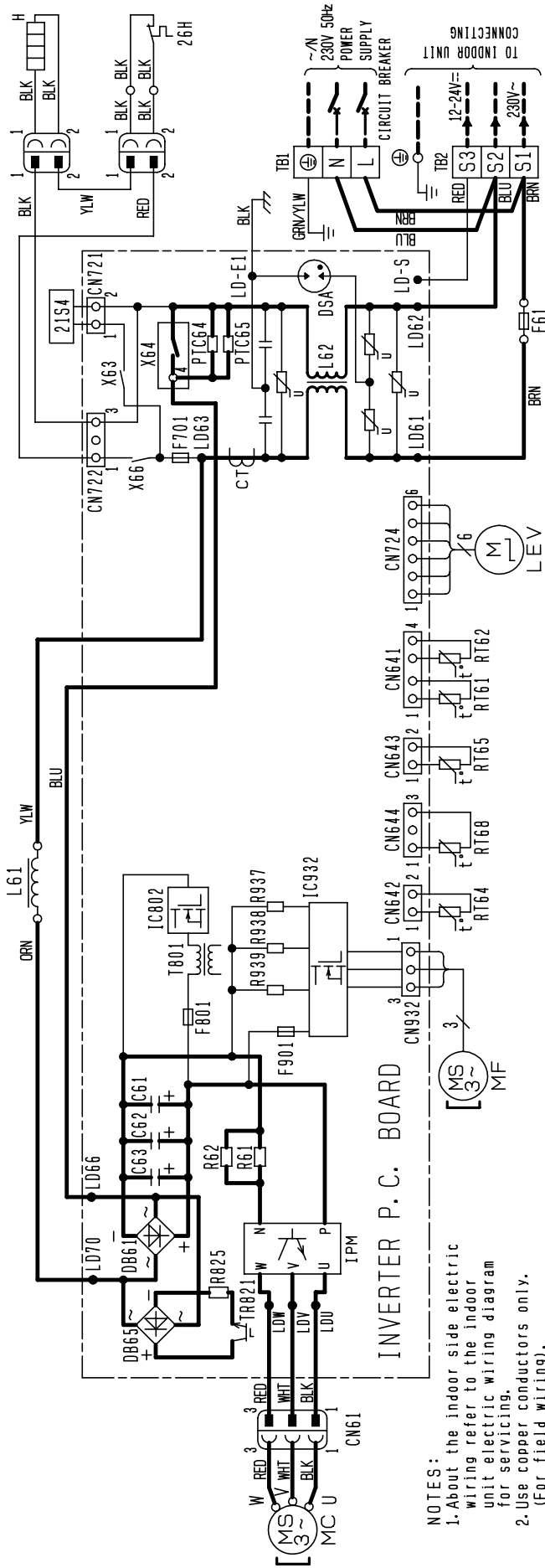

- NOTES:
- About the indoor side electric wiring refer to the indoor unit electric wiring diagram for servicing.
  - Use copper conductors only. (For field wiring).

SYMBOL	NAME	SYMBOL	NAME	SYMBOL	NAME
CT	CURRENT TRANSFORMER	LEV	EXPANSION VALVE COIL	R61, R62	CURRENT-DETECTING RESISTOR
C61, C62, C63	SMOOTHING CAPACITOR	MC	COMPRESSOR	R825, R937	CURRENT-DETECTING RESISTOR
DB61, DB65	DIODE MODULE	MF	FAN MOTOR	R938, R939	CURRENT-DETECTING RESISTOR
DSA	SURGE ABSORBER	PTC64, PTC65	CIRCUIT PROTECTION	TBL, TB2	TERMINAL BLOCK
F61	FUSE (T20AL250V)	RT61	DEFROST THERMISTOR	TR821	SWITCHING POWER TRANSISTOR
F701, F901, F902	FUSE (T3, 15AL250V)	RT62	DISCHARGE TEMP. THERMISTOR	T801	TRANSFORMER
IC802	INTELLIGENT POWER DEVICE	RT64	F.IN TEMP. THERMISTOR	X63, X64, X66	RELAY
IPM, IC932	INTELLIGENT POWER MODULE	RT65	AMBIENT TEMP. THERMISTOR	2154	REVERSING VALVE COIL
L61	REACTOR	RT68	OUTDOOR HEAT EXCHANGER	H	DEFROST HEATER
L62	CMC COIL		TEMP. THERMISTOR.	26H	HEATER PROTECTOR

# MUZ-GE50VA

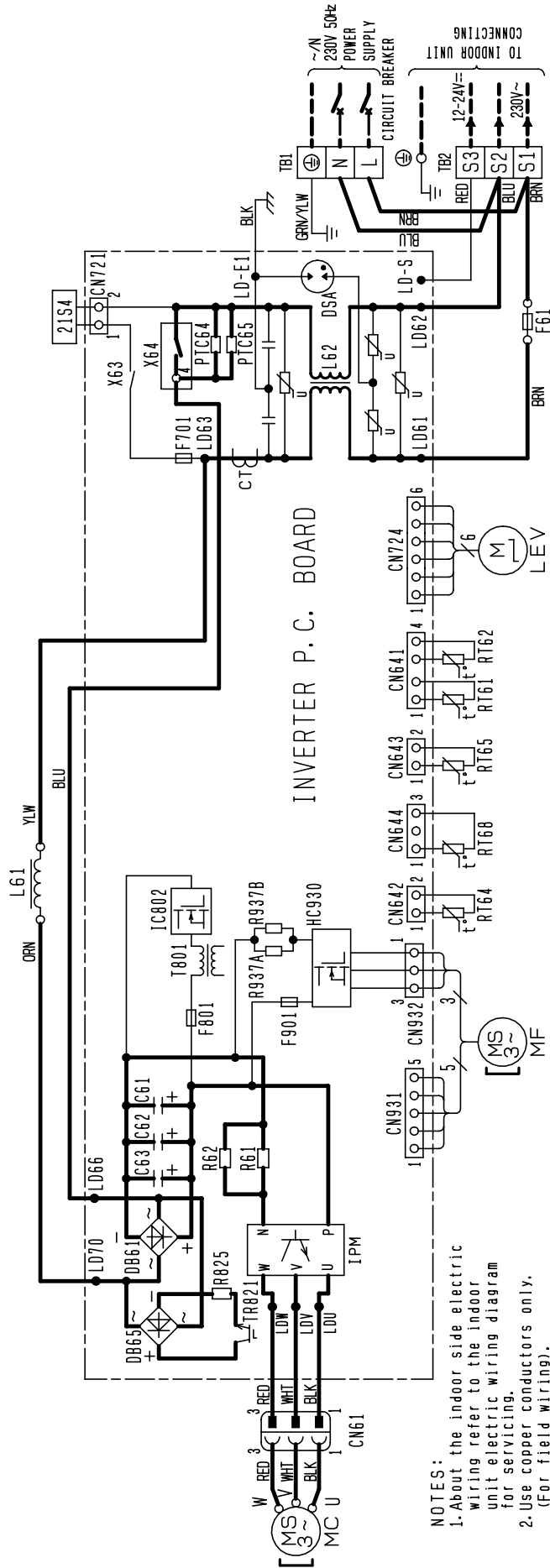

- NOTES:**
- About the indoor side electric wiring refer to the indoor unit electric wiring diagram for servicing.
  - Use copper conductors only. (For field wiring).

SYMBOL	NAME	SYMBOL	NAME	SYMBOL	NAME
CT	CURRENT TRANSFORMER	LEV	EXPANSION VALVE COIL	R61, R62	CURRENT-DETECTING RESISTOR
C61, C62, C63	SMOOTHING CAPACITOR	MC	COMPRESSOR	R825	CURRENT-DETECTING RESISTOR
DB61, DB65	DIODE MODULE	MF	FAN MOTOR	R937A, R937B	CURRENT-DETECTING RESISTOR
DSA	SURGE ABSORBER	PTC64, PTC65	CIRCUIT PROTECTION	TB1, TB2	TERMINAL BLOCK
F61	FUSE (T20A1.250V)	RT61	DEFROST THERMISTOR	TR821	SWITCHING POWER TRANSISTOR
F701, F801, F901	FUSE (T3.15A1.250V)	RT62	DISCHARGE TEMP. THERMISTOR	T801	TRANSFORMER
HC930, IPM	INTELLIGENT POWER MODULE	RT64	FAN TEMP. THERMISTOR	X63, X64	RELAY
IC802	INTELLIGENT POWER DEVICE	RT65	AMBIENT TEMP. THERMISTOR	21S4	REVERSING VALVE COIL
L61	REACTOR	RT68	OUTDOOR HEAT EXCHANGER TEMP. THERMISTOR.		
L62	CMC COIL				

# MUZ-GE50VAH

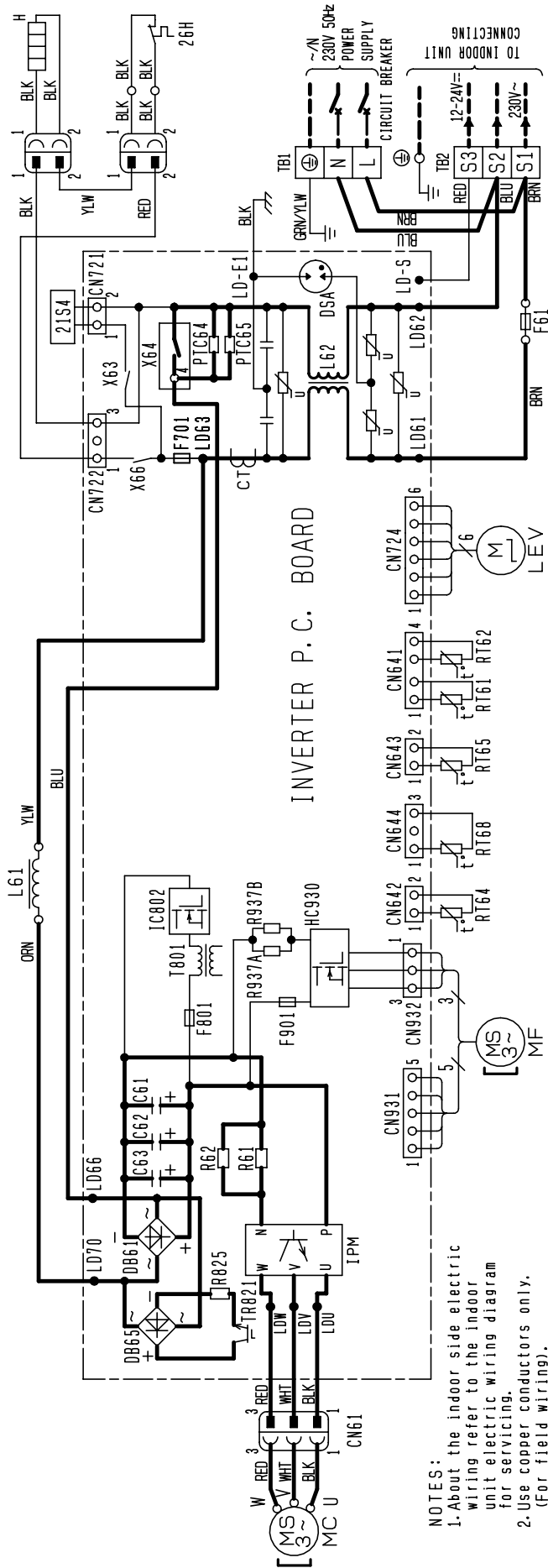

SYMBOL	NAME	SYMBOL	NAME	SYMBOL	NAME
CT	CURRENT TRANSFORMER	LEV	EXPANSION VALVE COIL	R61, R62	CURRENT-DETECTING RESISTOR
C61, C62, C63	SMOOTHING CAPACITOR	MC	COMPRESSOR	R825	CURRENT-DETECTING RESISTOR
DB61, DB65	DIODE MODULE	MF	FAN MOTOR	R937A, R937B	CURRENT-DETECTING RESISTOR
DSA	SURGE ABSORBER	PTC64, PTC65	CIRCUIT PROTECTION	TB1, TB2	TERMINAL BLOCK
F61	FUSE (T20AL250V)	RT61	DEFROST THERMISTOR	TR821	SWITCHING POWER TRANSISTOR
F701, F801, F901	FUSE (T3, 15AL250V)	RT62	DISCHARGE TEMP. THERMISTOR	T801	TRANSFORMER
HC930, IPM	INTELLIGENT POWER MODULE	RT64	FIN TEMP. THERMISTOR	X63, X64, X66	RELAY
IC802	INTELLIGENT POWER DEVICE REACTOR	RT65	AMBIENT TEMP. THERMISTOR	21S4	REVERSING VALVE COIL
L61	CMC COIL	RT68	OUTDOOR HEAT EXCHANGER TEMP. THERMISTOR.	H	DEFROST HEATER
L62				26H	HEATER PROTECTOR



MUZ-GE60VA MUZ-GE71VA

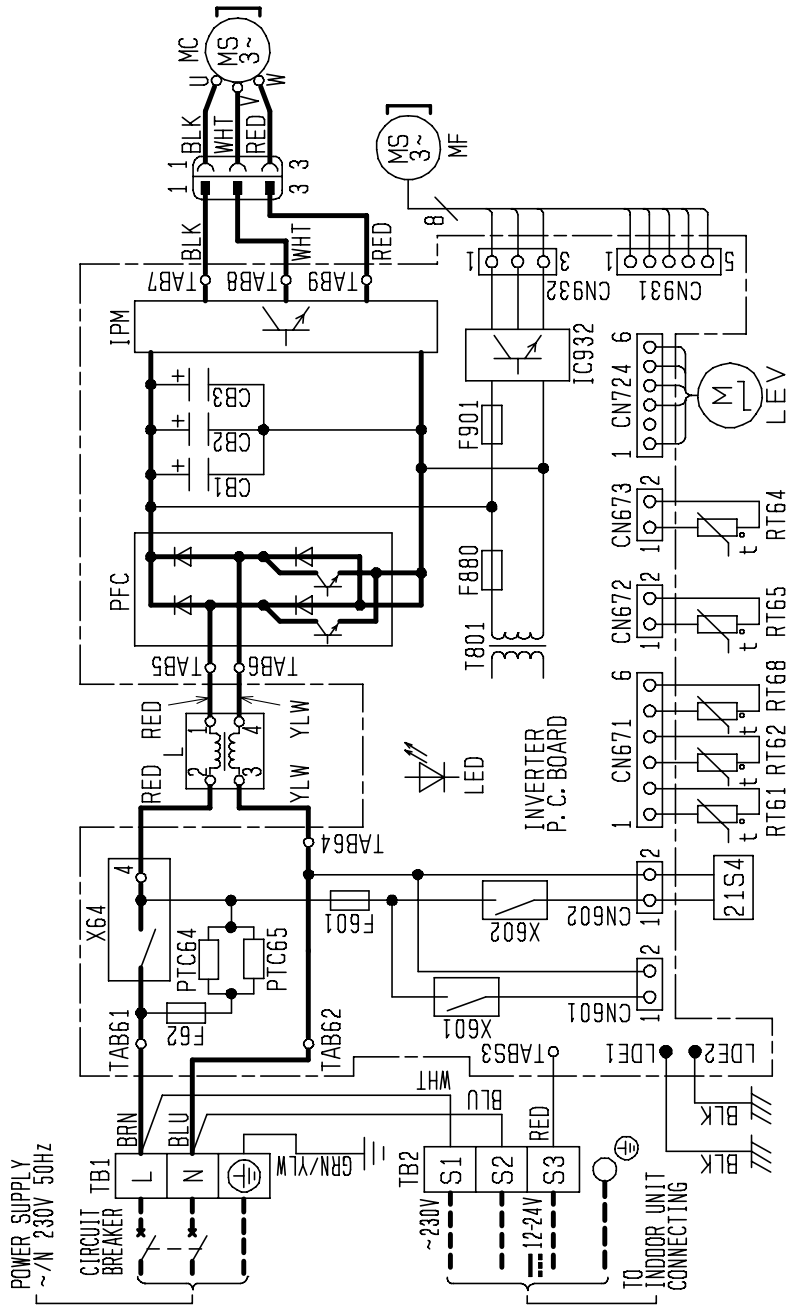

NOTES 1. About the indoor side electric wiring, refer to the indoor unit electric wiring diagram for servicing.  
 2. Use copper conductors only (for field wiring).  
 3. Symbols indicate. □: Terminal block

SYMBOL	NAME	SYMBOL	NAME
CB1 ~3	SMOOTHING CAPACITOR	PTC65	CIRCUIT PROTECTION
F601	FUSE (T3, 15AL250V)	RT61	DEFROST THERMISTOR
F62	FUSE (T2AL250V)	RT62	DISCHARGE TEMP. THERMISTOR
F880	FUSE (T3, 15AL250V)	RT64	FIN TEMP. THERMISTOR
F901	FUSE (T3, 15AL250V)	RT65	AMBIENT TEMP. THERMISTOR
IC932	INTELLIGENT POWER MODULE	RT68	OUTDOOR HEAT EXCHANGER TEMP. THERMISTOR
IPM	INTELLIGENT POWER MODULE REACTOR	TB1, TB2	TERMINAL BLOCK
LEV	EXPANSION VALVE COIL	T801	TRANSFORMER
MC	COMPRESSOR	X601	RELAY
MF	FAN MOTOR	X602	RELAY
PFC	POWER FACTOR CONTROLLER	X64	RELAY
PTC64	CIRCUIT PROTECTION	21S4	REVERSING VALVE SOLENOID COIL

MUZ-GE25VA MUZ-GE25VAH

Unit: mm

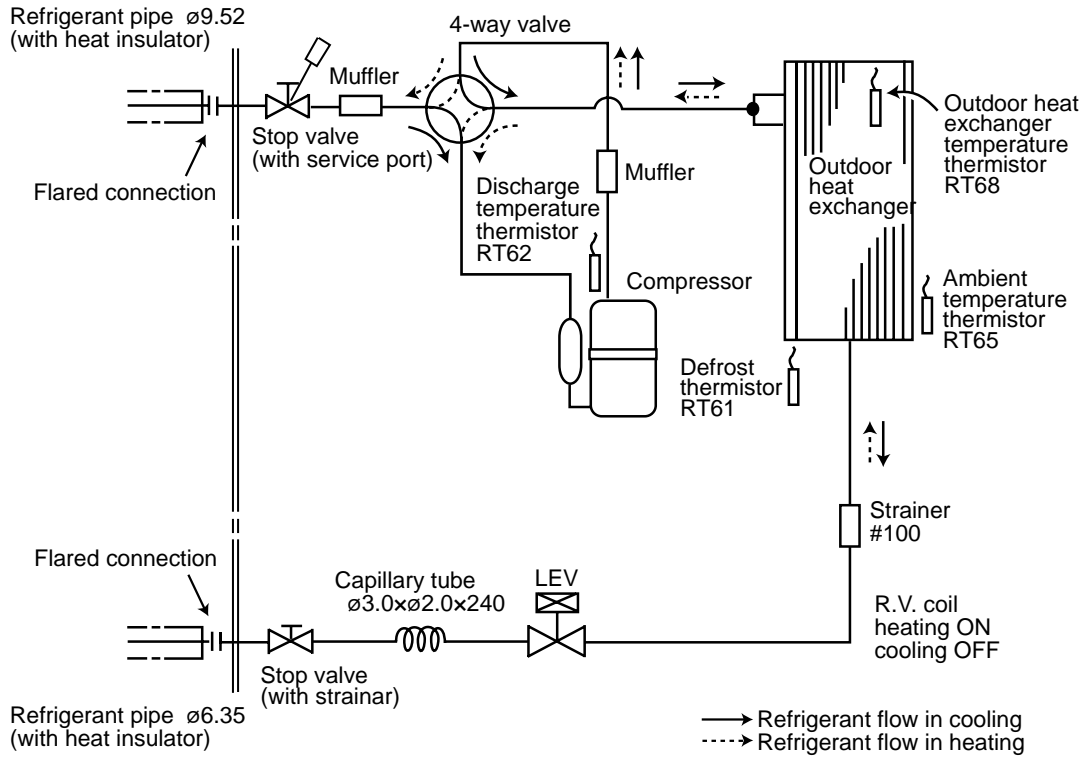

MUZ-GE35VA MUZ-GE35VAH MUZ-GE42VA MUZ-GE42VAH

Unit: mm

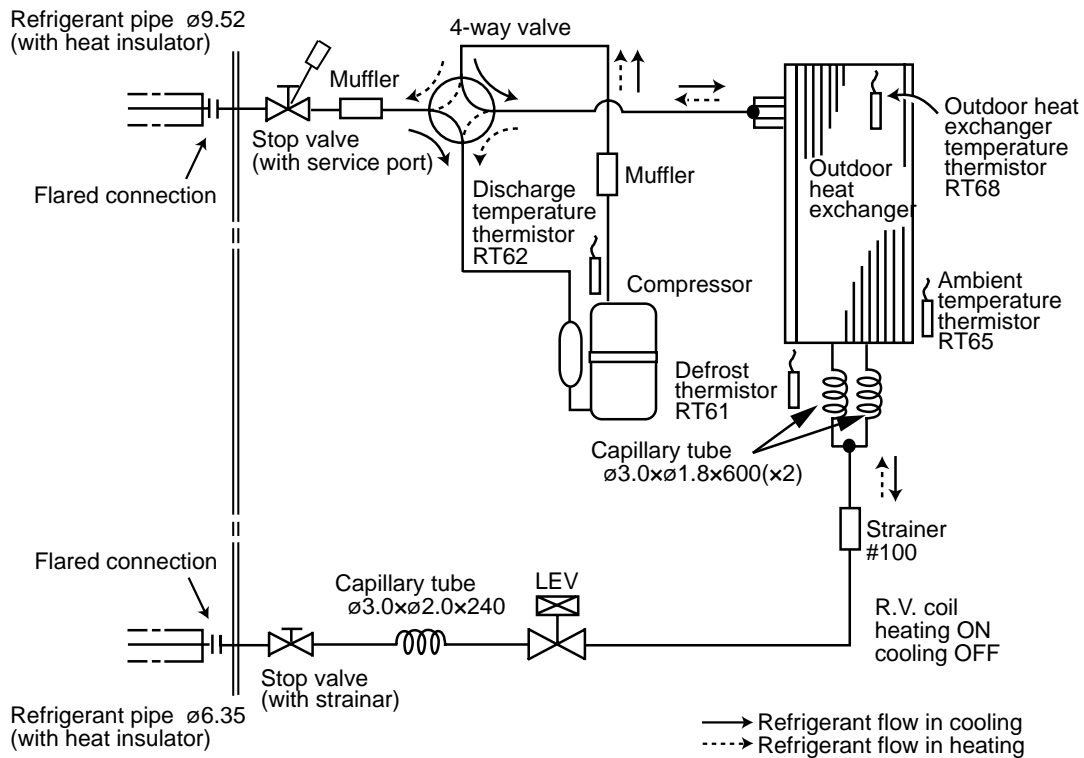

**MUZ-GE50VA MUZ-GE50VAH**

Unit: mm

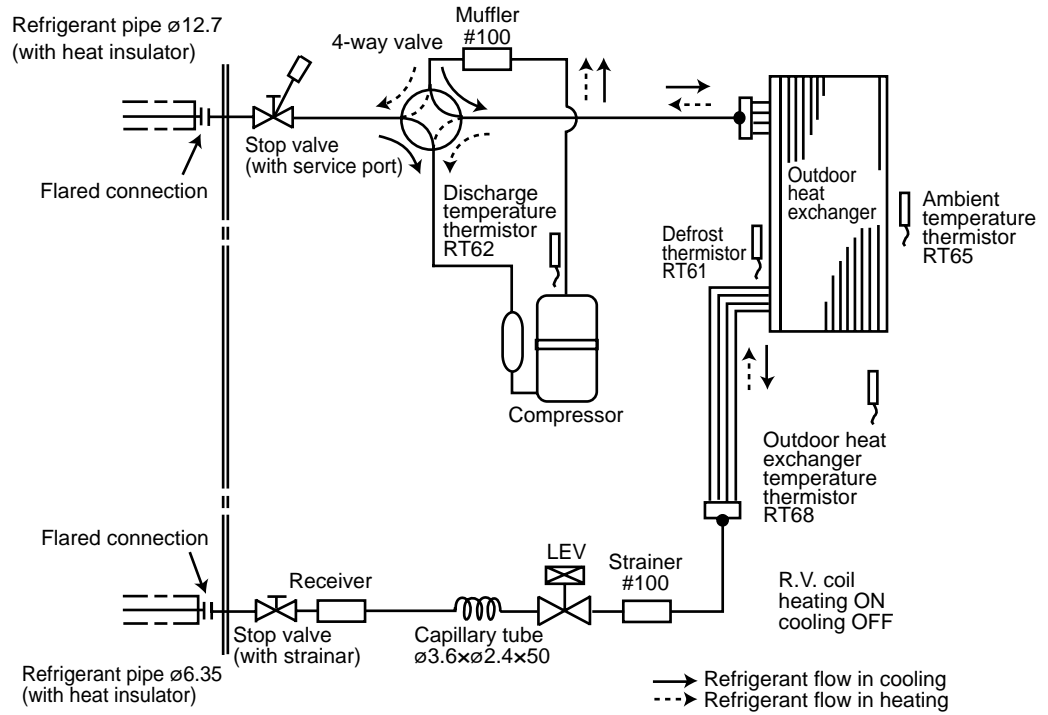

**MUZ-GE60VA**

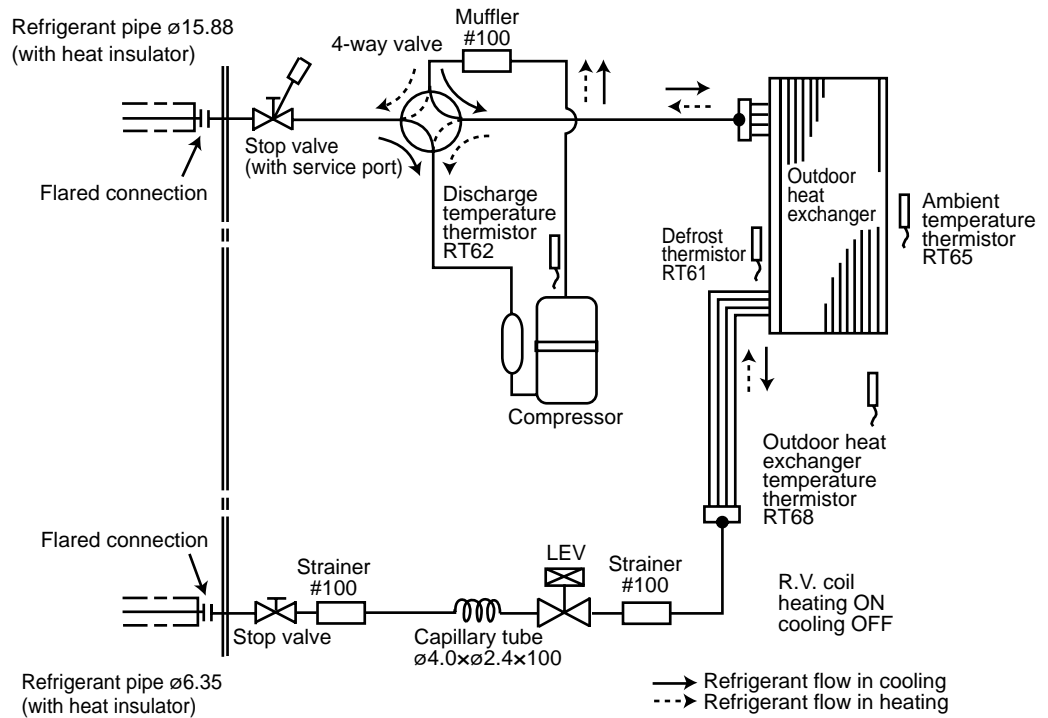

# MUZ-GE71VA

Unit: mm

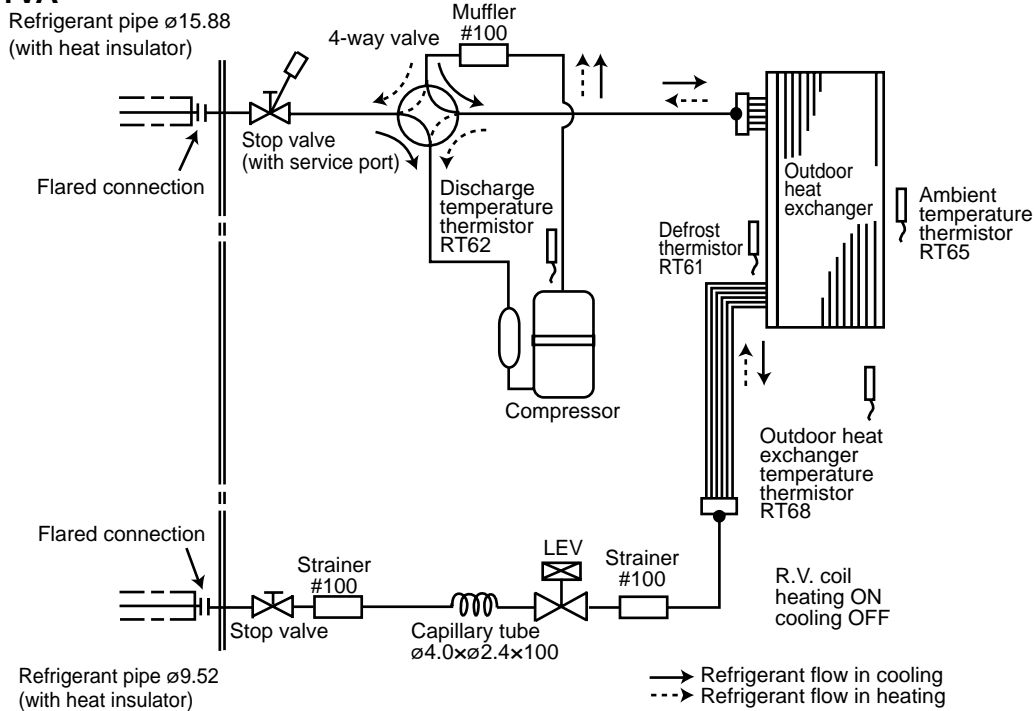

## MAX. REFRIGERANT PIPING LENGTH and MAX. HEIGHT DIFFERENCE

	Refrigerant piping: m		Piping size O.D: mm	
	Max. Length A	Max. Height difference B	Gas	Liquid
<b>MUZ-GE25/35/42</b>	20	12	9.52	6.35
<b>MUZ-GE50</b>	30	15	12.7	
<b>MUZ-GE60</b>			15.88	9.52
<b>MUZ-GE71</b>				

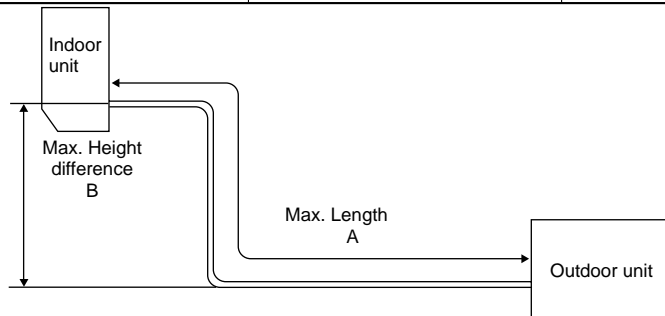

## ADDITIONAL REFRIGERANT CHARGE (R410A: g)

Model	Outdoor unit precharged	Refrigerant piping length (one way)												
		5 m	6 m	7 m	8 m	9 m	10 m	11 m	12 m	13 m	14 m	15 m	20 m	
<b>MUZ-GE25</b>	800	0	0	0	30	60	90	120	150	180	210	240	390	
<b>MUZ-GE35/42</b>	1,150													

Calculation: X g = 30 g/m × (Refrigerant piping length (m) - 7)

Model	Outdoor unit precharged	Refrigerant piping length (one way)					
		7 m	10 m	15 m	20 m	25 m	30 m
<b>MUZ-GE50</b>	1,550	0	60	160	260	360	460

Calculation: X g = 20 g/m × (Refrigerant piping length (m) - 7)

Model	Outdoor unit precharged	Refrigerant piping length (one way)					
		7 m	10 m	15 m	20 m	25 m	30 m
<b>MUZ-GE60</b>	1,550	0	0	100	200	300	400

Calculation: X g = 20 g/m × (Refrigerant piping length (m) - 10)

Model	Outdoor unit precharged	Refrigerant piping length (one way)					
		7 m	10 m	15 m	20 m	25 m	30 m
<b>MUZ-GE71</b>	1,900	0	0	275	550	825	1,100

Calculation: X g = 55 g/m × (Refrigerant piping length (m) - 10)

**NOTE:** Refrigerant piping exceeding 7 m requires additional refrigerant charge according to the calculation.

**MUZ-GE25VA MUZ-GE25VAH MUZ-GE35VA MUZ-GE35VAH MUZ-GE42VA MUZ-GE42VAH  
MUZ-GE50VA MUZ-GE50VAH MUZ-GE60VA MUZ-GE71VA**

The standard specifications apply only to the operation of the air conditioner under normal conditions. Since operating conditions vary according to the areas where these units are installed, the following information has been provided to clarify the operating characteristics of the air conditioner under the conditions indicated by the performance curve.

**(1) GUARANTEED VOLTAGE**

198 ~ 264 V, 50 Hz

**(2) AIR FLOW**

Air flow should be set at MAX.

**(3) MAIN READINGS**

- |  |         |           |
|--|---------|-----------|
| (1) Indoor intake air wet-bulb temperature:  | °C [WB] | } Cooling |
| (2) Indoor outlet air wet-bulb temperature:  | °C [WB] |           |
| (3) Outdoor intake air dry-bulb temperature: | °C [DB] |           |
| (4) Total input:                             | W       | } Heating |
| (5) Indoor intake air dry-bulb temperature:  | °C [DB] |           |
| (6) Outdoor intake air wet-bulb temperature: | °C [WB] |           |
| (7) Total input:                             | W       |           |

Indoor air wet/dry bulb temperature difference on the left side of the following chart shows the difference between the indoor intake air wet/dry bulb temperature and the indoor outlet air wet/dry bulb temperature for your reference at service.

**How to measure the indoor air wet bulb / dry bulb temperature difference**

- Attach at least 2 sets of wet and dry bulb thermometers to the indoor air intake as shown in the figure, and at least 2 sets of wet and dry bulb thermometers to the indoor air outlet. The thermometers must be attached to the position where air speed is high.
- Attach at least 2 sets of wet and dry bulb thermometers to the outdoor air intake. Cover the thermometers to prevent direct rays of the sun.
- Check that the air filter is cleaned.
- Open windows and doors of room.
- Press the EMERGENCY OPERATION switch once (twice) to start the EMERGENCY COOL (HEAT) MODE.
- When system stabilizes after more than 15 minutes, measure temperature and take an average temperature.
- 10 minutes later, measure temperature again and check that the temperature does not change.

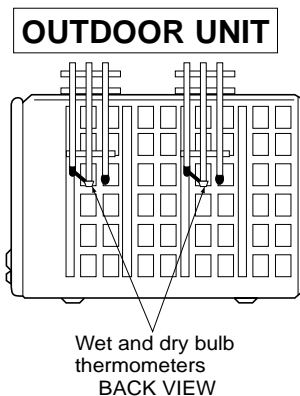
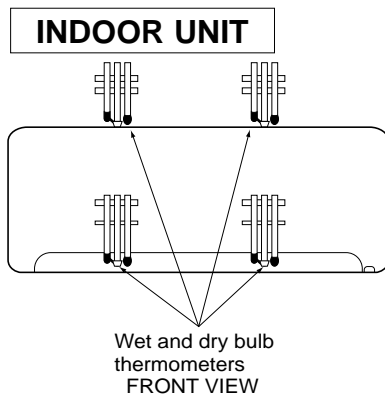

**8-1. CAPACITY AND INPUT CURVES**

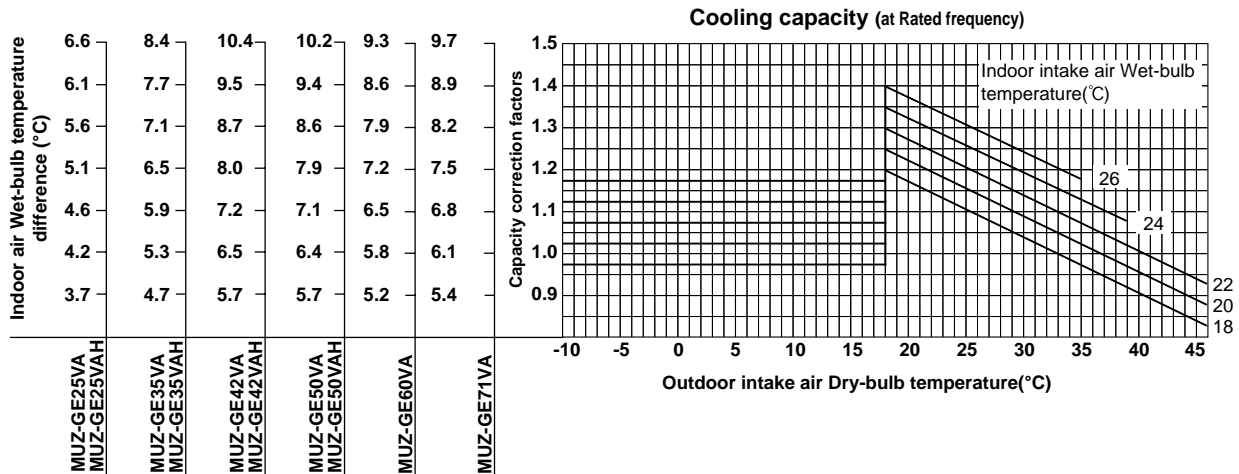

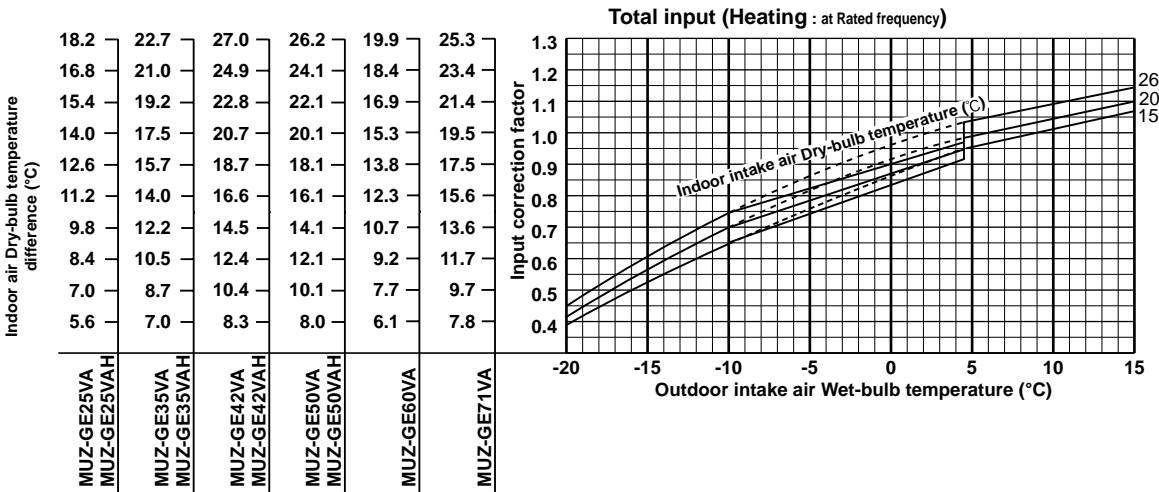
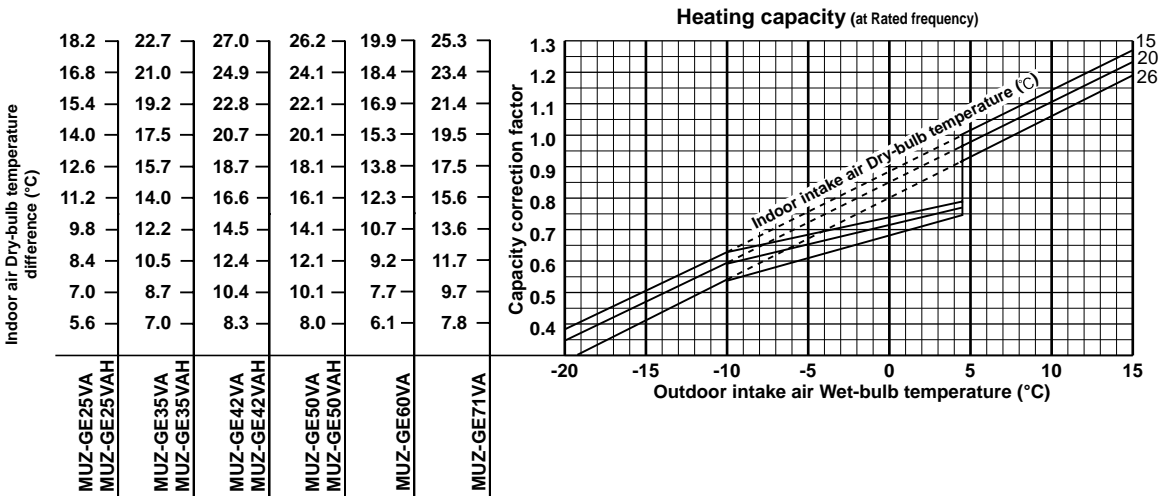
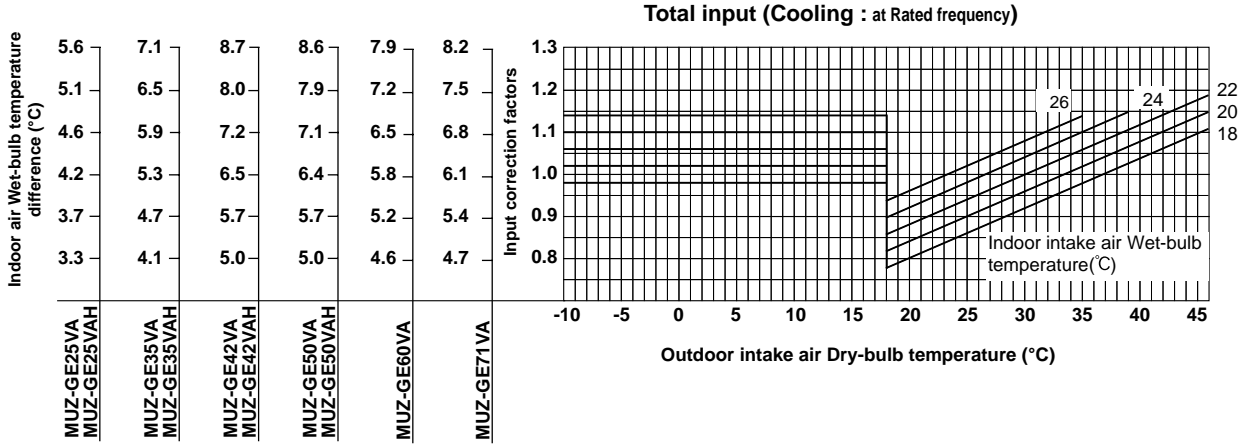
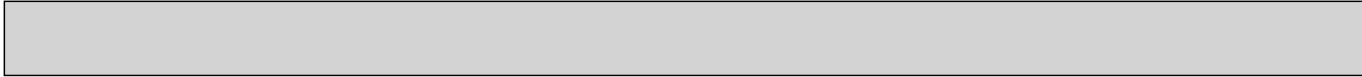

**NOTE:** The above broken lines are for the heating operation without any frost and defrost operation.

## 8-2. CAPACITY AND INPUT CORRECTION BY OPERATIONAL FREQUENCY OF COMPRESSOR

### MUZ-GE25VA MUZ-GE25VAH

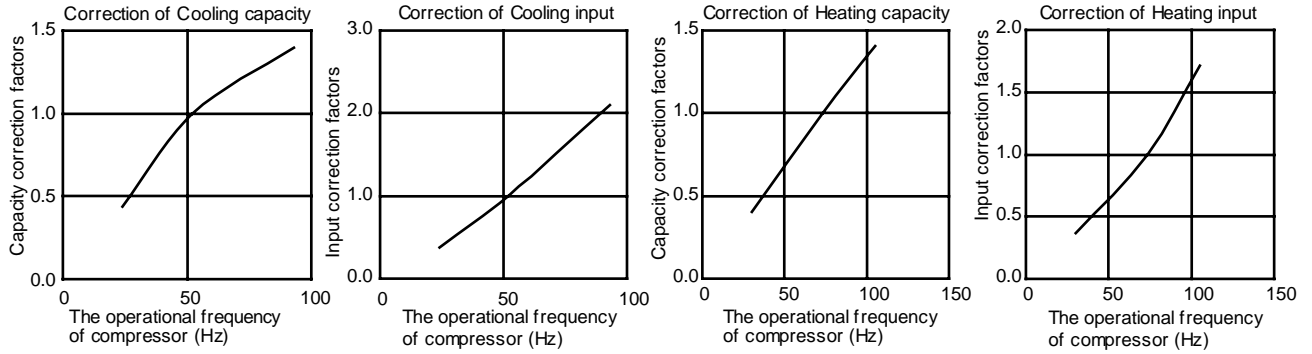

### MUZ-GE35VA MUZ-GE35VAH

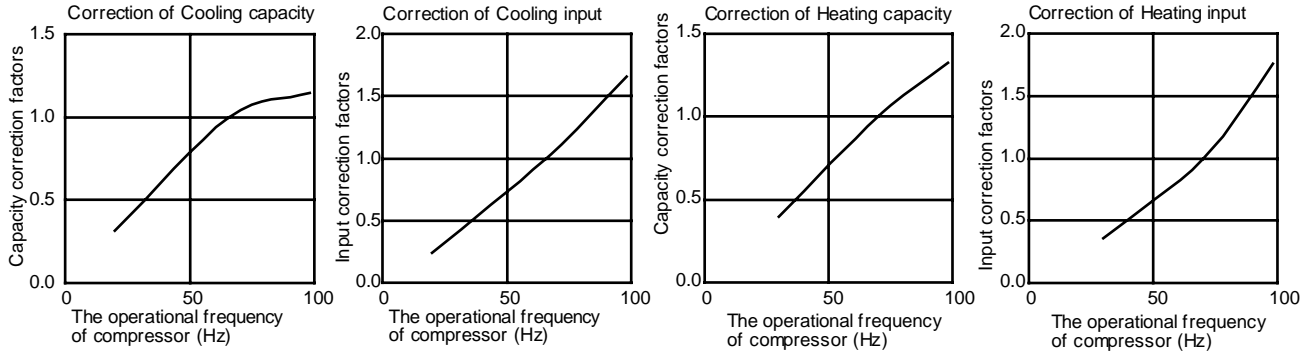

### MUZ-GE42VA MUZ-GE42VAH

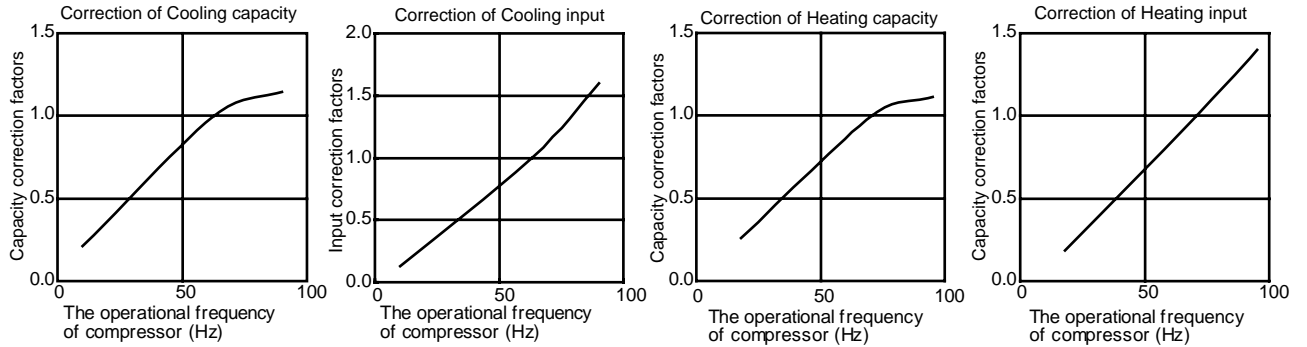

### MUZ-GE50VA MUZ-GE50VAH

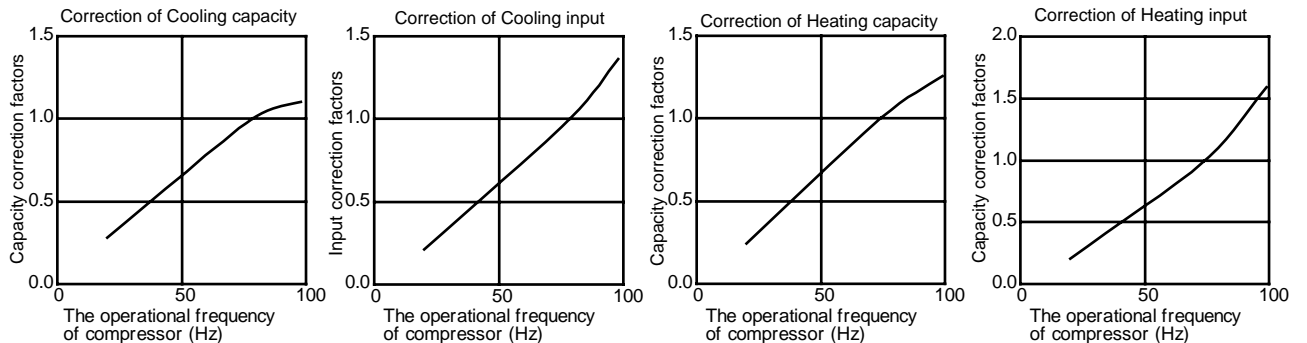

### MUZ-GE60VA

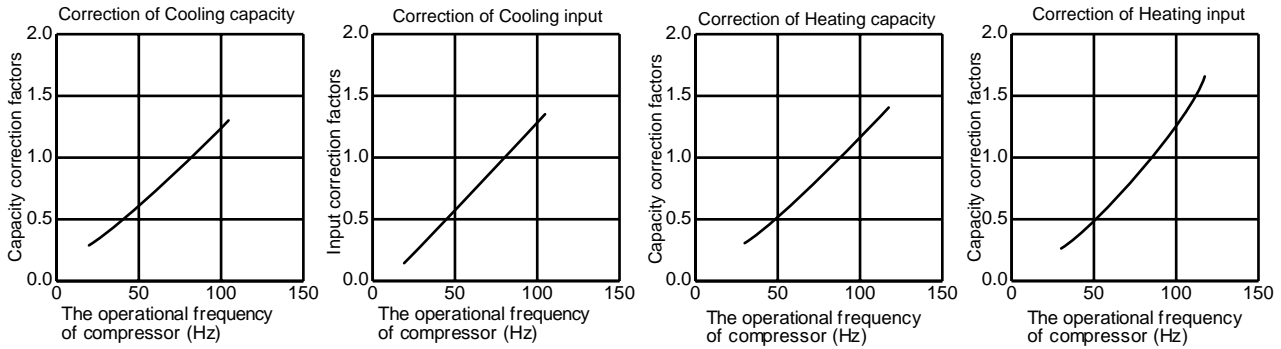

### MUZ-GE71VA

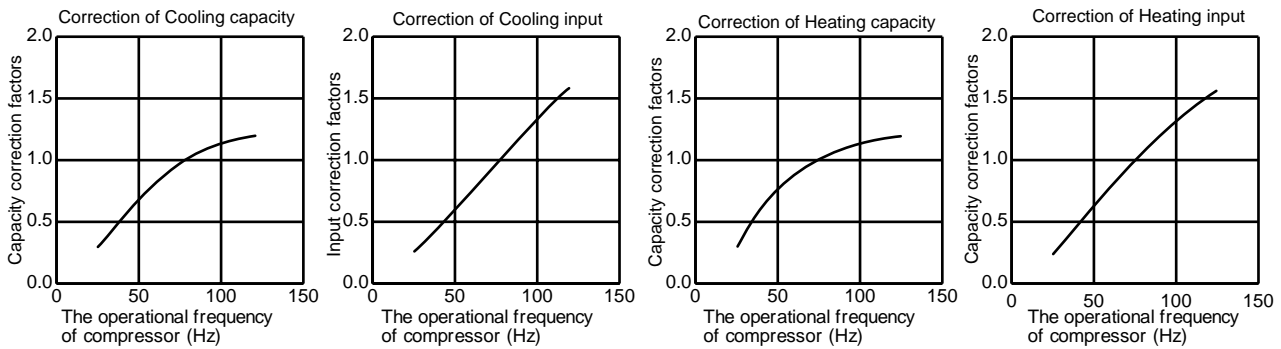

## 8-3. HOW TO OPERATE FIXED-FREQUENCY OPERATION

<Test run operation>

1. Press EMERGENCY OPERATION switch to start COOL or HEAT mode (COOL: Press once, HEAT: Press twice).
2. Test run operation starts and continues to operate for 30 minutes.
3. Compressor operates at rated frequency in COOL mode or 58 Hz (**MUZ-GE25/35/42/50/60VA**)/74 Hz (**MUZ-GE71VA**) in HEAT mode.
4. Indoor fan operates at High speed.
5. After 30 minutes, test run operation finishes and EMERGENCY OPERATION starts (operation frequency of compressor varies).
6. To cancel test run operation (EMERGENCY OPERATION), press EMERGENCY OPERATION switch or any button on remote controller.

## 8-4. OUTDOOR LOW PRESSURE AND OUTDOOR UNIT CURRENT

### COOL operation

- ① Both indoor and outdoor unit are under the same temperature/ humidity condition.
- ② Operation: TEST RUN OPERATION (Refer to 8-3.)

Dry-bulb temperature (°C)	Relative humidity (%)
20	50
25	60
30	70

### Outdoor low pressure

#### MUZ-GE25VA MUZ-GE25VAH

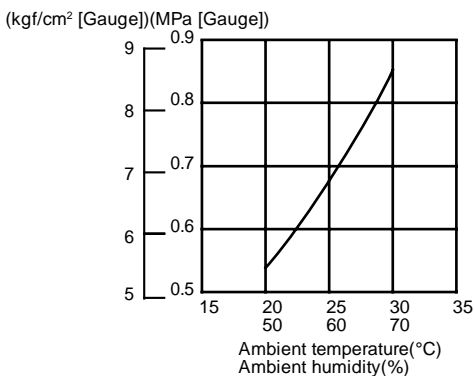

#### MUZ-GE35VA MUZ-GE35VAH

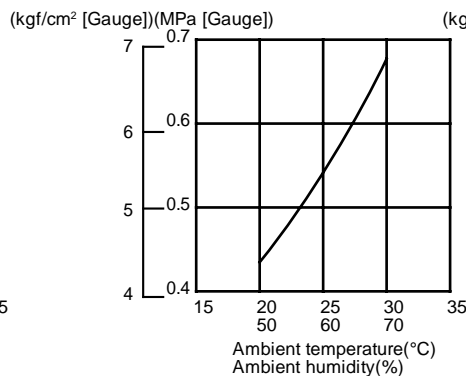

#### MUZ-GE42VA MUZ-GE42VAH

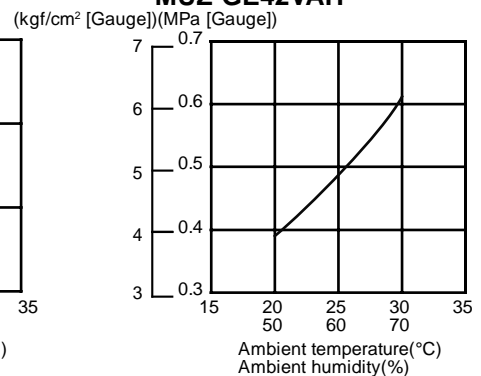



**MUZ-GE50VA  
MUZ-GE50VAH**

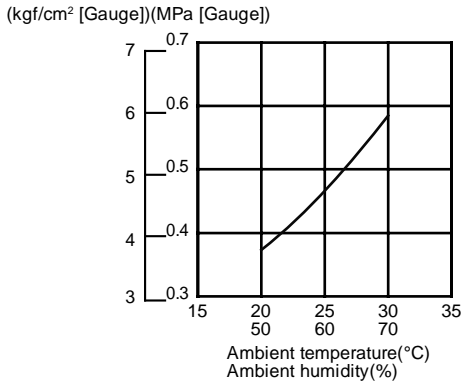

**MUZ-GE60VA**

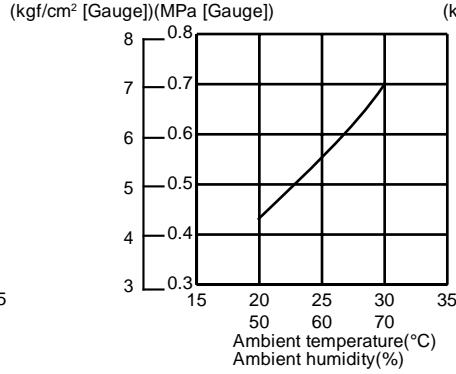

**MUZ-GE71VA**

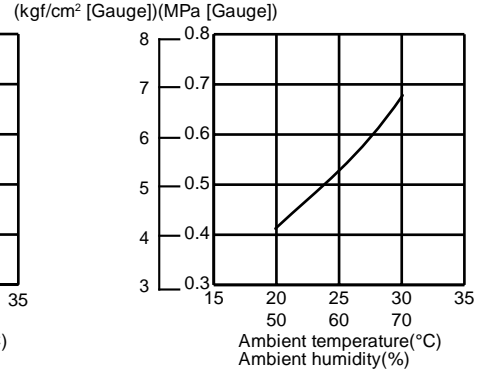

**NOTE:**

The unit of pressure has been changed to MPa on the international system of units (SI unit system)  
The conversion factor is: **1 (MPa [Gauge]) = 10.2 (kgf/cm² [Gauge])**

**Outdoor unit current**

**MUZ-GE25VA MUZ-GE25VAH**

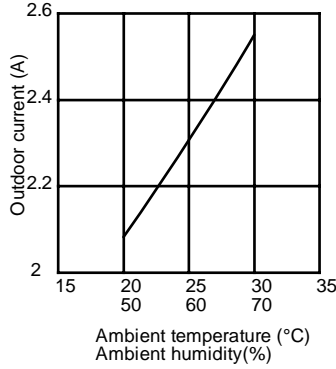

**MUZ-GE35VA MUZ-GE35VAH**

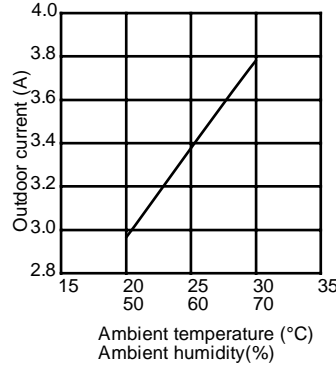

**MUZ-GE42VA MUZ-GE42VAH**

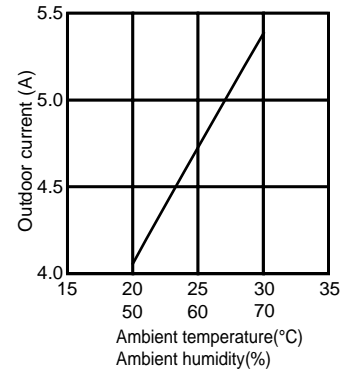

**MUZ-GE50VA MUZ-GE50VAH**

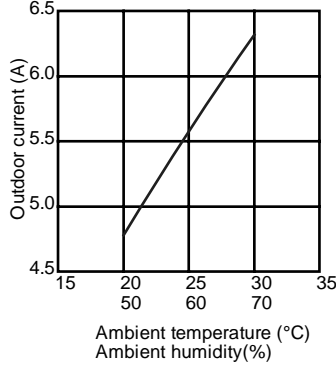

**MUZ-GE60VA**

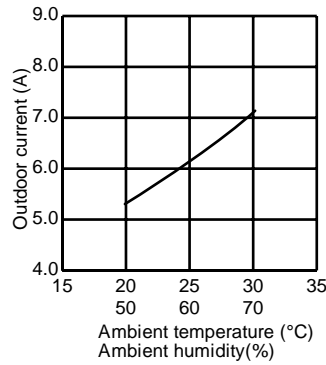

**MUZ-GE71VA**

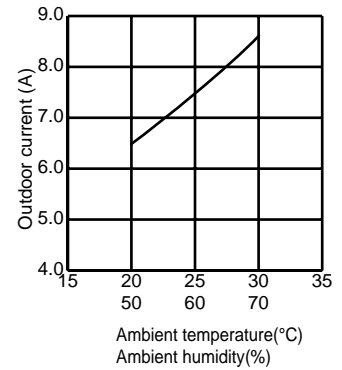

## HEAT operation

① Condition:

	Indoor	Outdoor			
		2	7	15	20.0
Dry bulb temperature (°C)	20.0	2	7	15	20.0
Wet bulb temperature (°C)	14.5	1	6	12	14.5

② Operation: Test run operation (Refer to 8-3.)

### Outdoor unit current

**MUZ-GE25VA MUZ-GE25VAH**

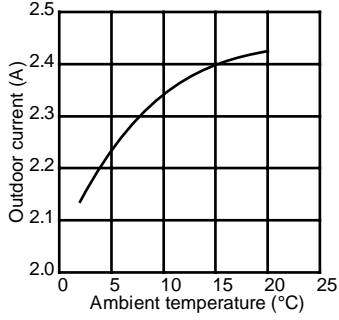

**MUZ-GE35VA MUZ-GE35VAH**

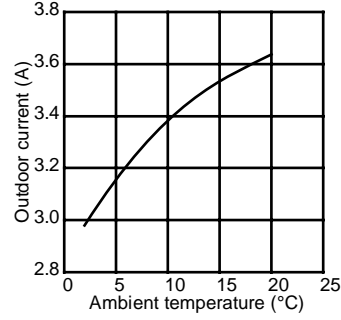

**MUZ-GE42VA MUZ-GE42VAH**

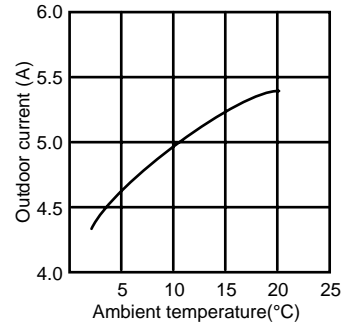

**MUZ-GE50VA MUZ-GE50VAH**

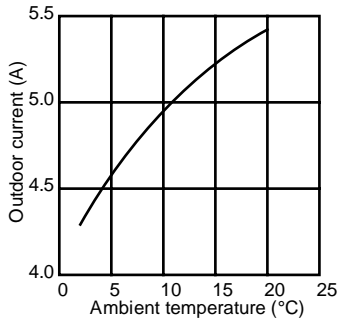

**MUZ-GE60VA**

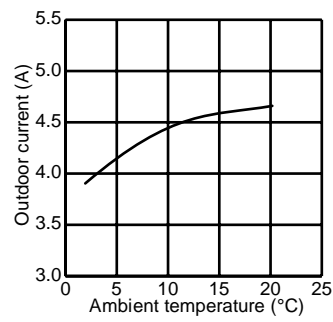

**MUZ-GE71VA**

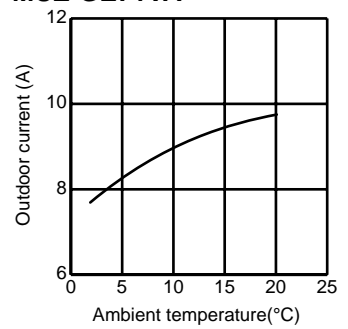

**PERFORMANCE DATA COOL operation at Rated frequency**

**MUZ-GE25VA MUZ-GE25VAH**

CAPACITY: 2.5 kW

SHF: 0.96

INPUT: 545 W

INDOOR DB (°C)	INDOOR WB (°C)	OUTDOOR DB (°C)															
		21				25				27				30			
		Q	SHC	SHF	INPUT	Q	SHC	SHF	INPUT	Q	SHC	SHF	INPUT	Q	SHC	SHF	INPUT
21	18	2.94	2.29	0.78	436	2.81	2.19	0.78	458	2.70	2.11	0.78	480	2.60	2.03	0.78	501
21	20	3.06	2.02	0.66	458	2.94	1.94	0.66	485	2.85	1.88	0.66	496	2.75	1.82	0.66	518
22	18	2.94	2.41	0.82	436	2.81	2.31	0.82	458	2.70	2.21	0.82	480	2.60	2.13	0.82	501
22	20	3.06	2.14	0.70	458	2.94	2.06	0.70	485	2.85	2.00	0.70	496	2.75	1.93	0.70	518
22	22	3.19	1.85	0.58	474	3.08	1.78	0.58	504	3.00	1.74	0.58	518	2.88	1.67	0.58	540
23	18	2.94	2.53	0.86	436	2.81	2.42	0.86	458	2.70	2.32	0.86	480	2.60	2.24	0.86	501
23	20	3.06	2.27	0.74	458	2.94	2.17	0.74	485	2.85	2.11	0.74	496	2.75	2.04	0.74	518
23	22	3.19	1.98	0.62	474	3.08	1.91	0.62	504	3.00	1.86	0.62	518	2.88	1.78	0.62	540
24	18	2.94	2.64	0.90	436	2.81	2.53	0.90	458	2.70	2.43	0.90	480	2.60	2.34	0.90	501
24	20	3.06	2.39	0.78	458	2.94	2.29	0.78	485	2.85	2.22	0.78	496	2.75	2.15	0.78	518
24	22	3.19	2.10	0.66	474	3.08	2.03	0.66	504	3.00	1.98	0.66	518	2.88	1.90	0.66	540
24	24	3.35	1.81	0.54	496	3.23	1.74	0.54	523	3.15	1.70	0.54	540	3.05	1.65	0.54	567
25	18	2.94	2.76	0.94	436	2.81	2.64	0.94	458	2.70	2.54	0.94	480	2.60	2.44	0.94	501
25	20	3.06	2.51	0.82	458	2.94	2.41	0.82	485	2.85	2.34	0.82	496	2.75	2.26	0.82	518
25	22	3.19	2.23	0.70	474	3.08	2.15	0.70	504	3.00	2.10	0.70	518	2.88	2.01	0.70	540
25	24	3.35	1.94	0.58	496	3.23	1.87	0.58	523	3.15	1.83	0.58	540	3.05	1.77	0.58	567
26	18	2.94	2.88	0.98	436	2.81	2.76	0.98	458	2.70	2.65	0.98	480	2.60	2.55	0.98	501
26	20	3.06	2.63	0.86	458	2.94	2.53	0.86	485	2.85	2.45	0.86	496	2.75	2.37	0.86	518
26	22	3.19	2.36	0.74	474	3.08	2.28	0.74	504	3.00	2.22	0.74	518	2.88	2.13	0.74	540
26	24	3.35	2.08	0.62	496	3.23	2.00	0.62	523	3.15	1.95	0.62	540	3.05	1.89	0.62	567
26	26	3.45	1.73	0.50	523	3.35	1.68	0.50	550	3.30	1.65	0.50	567	3.20	1.60	0.50	583
27	18	2.94	2.94	1.00	436	2.81	2.81	1.00	458	2.70	2.70	1.00	480	2.60	2.60	1.00	501
27	20	3.06	2.76	0.90	458	2.94	2.64	0.90	485	2.85	2.57	0.90	496	2.75	2.48	0.90	518
27	22	3.19	2.49	0.78	474	3.08	2.40	0.78	504	3.00	2.34	0.78	518	2.88	2.24	0.78	540
27	24	3.35	2.21	0.66	496	3.23	2.13	0.66	523	3.15	2.08	0.66	540	3.05	2.01	0.66	567
27	26	3.45	1.86	0.54	523	3.35	1.81	0.54	550	3.30	1.78	0.54	567	3.20	1.73	0.54	583
28	18	2.94	2.94	1.00	436	2.81	2.81	1.00	458	2.70	2.70	1.00	480	2.60	2.60	1.00	501
28	20	3.06	2.88	0.94	458	2.94	2.76	0.94	485	2.85	2.68	0.94	496	2.75	2.59	0.94	518
28	22	3.19	2.61	0.82	474	3.08	2.52	0.82	504	3.00	2.46	0.82	518	2.88	2.36	0.82	540
28	24	3.35	2.35	0.70	496	3.23	2.26	0.70	523	3.15	2.21	0.70	540	3.05	2.14	0.70	567
28	26	3.45	2.00	0.58	523	3.35	1.94	0.58	550	3.30	1.91	0.58	567	3.20	1.86	0.58	583
29	18	2.94	2.94	1.00	436	2.81	2.81	1.00	458	2.70	2.70	1.00	480	2.60	2.60	1.00	501
29	20	3.06	3.00	0.98	458	2.94	2.88	0.98	485	2.85	2.79	0.98	496	2.75	2.70	0.98	518
29	22	3.19	2.74	0.86	474	3.08	2.64	0.86	504	3.00	2.58	0.86	518	2.88	2.47	0.86	540
29	24	3.35	2.48	0.74	496	3.23	2.39	0.74	523	3.15	2.33	0.74	540	3.05	2.26	0.74	567
29	26	3.45	2.14	0.62	523	3.35	2.08	0.62	550	3.30	2.05	0.62	567	3.20	1.98	0.62	583
30	18	2.94	2.94	1.00	436	2.81	2.81	1.00	458	2.70	2.70	1.00	480	2.60	2.60	1.00	501
30	20	3.06	3.06	1.00	458	2.94	2.94	1.00	485	2.85	2.85	1.00	496	2.75	2.75	1.00	518
30	22	3.19	2.87	0.90	474	3.08	2.77	0.90	504	3.00	2.70	0.90	518	2.88	2.59	0.90	540
30	24	3.35	2.61	0.78	496	3.23	2.52	0.78	523	3.15	2.46	0.78	540	3.05	2.38	0.78	567
30	26	3.45	2.28	0.66	523	3.35	2.21	0.66	550	3.30	2.18	0.66	567	3.20	2.11	0.66	583
31	18	2.94	2.94	1.00	436	2.81	2.81	1.00	458	2.70	2.70	1.00	480	2.60	2.60	1.00	501
31	20	3.06	3.06	1.00	458	2.94	2.94	1.00	485	2.85	2.85	1.00	496	2.75	2.75	1.00	518
31	22	3.19	3.00	0.94	474	3.08	2.89	0.94	504	3.00	2.82	0.94	518	2.88	2.70	0.94	540
31	24	3.35	2.75	0.82	496	3.23	2.64	0.82	523	3.15	2.58	0.82	540	3.05	2.50	0.82	567
31	26	3.45	2.42	0.70	523	3.35	2.35	0.70	550	3.30	2.31	0.70	567	3.20	2.24	0.70	583
32	18	2.94	2.94	1.00	436	2.81	2.81	1.00	458	2.70	2.70	1.00	480	2.60	2.60	1.00	501
32	20	3.06	3.06	1.00	458	2.94	2.94	1.00	485	2.85	2.85	1.00	496	2.75	2.75	1.00	518
32	22	3.19	3.12	0.98	474	3.08	3.01	0.98	504	3.00	2.94	0.98	518	2.88	2.82	0.98	540
32	24	3.35	2.88	0.86	496	3.23	2.77	0.86	523	3.15	2.71	0.86	540	3.05	2.62	0.86	567
32	26	3.45	2.55	0.74	523	3.35	2.48	0.74	550	3.30	2.44	0.74	567	3.20	2.37	0.74	583

**NOTE** Q : Total capacity (kW) SHF : Sensible heat factor DB : Dry-bulb temperature  
 SHC : Sensible heat capacity (kW) INPUT : Total power input (W) WB : Wet-bulb temperature

**PERFORMANCE DATA COOL operation at Rated frequency**

**MUZ-GE25VA MUZ-GE25VAH**

CAPACITY: 2.5 kW

SHF: 0.96

INPUT: 545 W

INDOOR DB (°C)	INDOOR WB (°C)	OUTDOOR DB (°C)											
		35				40				46			
		Q	SHC	SHF	INPUT	Q	SHC	SHF	INPUT	Q	SHC	SHF	INPUT
21	18	2.45	1.91	0.78	534	2.25	1.76	0.78	567	2.08	1.62	0.78	589
21	20	2.58	1.70	0.66	556	2.40	1.58	0.66	583	2.23	1.47	0.66	616
22	18	2.45	2.01	0.82	534	2.25	1.85	0.82	567	2.08	1.70	0.82	589
22	20	2.58	1.80	0.70	556	2.40	1.68	0.70	583	2.23	1.56	0.70	616
22	22	2.73	1.58	0.58	578	2.55	1.48	0.58	610	2.38	1.38	0.58	632
23	18	2.45	2.11	0.86	534	2.25	1.94	0.86	567	2.08	1.78	0.86	589
23	20	2.58	1.91	0.74	556	2.40	1.78	0.74	583	2.23	1.65	0.74	616
23	22	2.73	1.69	0.62	578	2.55	1.58	0.62	610	2.38	1.47	0.62	632
24	18	2.45	2.21	0.90	534	2.25	2.03	0.90	567	2.08	1.87	0.90	589
24	20	2.58	2.01	0.78	556	2.40	1.87	0.78	583	2.23	1.74	0.78	616
24	22	2.73	1.80	0.66	578	2.55	1.68	0.66	610	2.38	1.57	0.66	632
24	24	2.88	1.55	0.54	600	2.70	1.46	0.54	627	2.55	1.38	0.54	654
25	18	2.45	2.30	0.94	534	2.25	2.12	0.94	567	2.08	1.95	0.94	589
25	20	2.58	2.11	0.82	556	2.40	1.97	0.82	583	2.23	1.82	0.82	616
25	22	2.73	1.91	0.70	578	2.55	1.79	0.70	610	2.38	1.66	0.70	632
25	24	2.88	1.67	0.58	600	2.70	1.57	0.58	627	2.55	1.48	0.58	654
26	18	2.45	2.40	0.98	534	2.25	2.21	0.98	567	2.08	2.03	0.98	589
26	20	2.58	2.21	0.86	556	2.40	2.06	0.86	583	2.23	1.91	0.86	616
26	22	2.73	2.02	0.74	578	2.55	1.89	0.74	610	2.38	1.76	0.74	632
26	24	2.88	1.78	0.62	600	2.70	1.67	0.62	627	2.55	1.58	0.62	654
26	26	3.03	1.51	0.50	621	2.85	1.43	0.50	649	2.68	1.34	0.50	676
27	18	2.45	2.45	1.00	534	2.25	2.25	1.00	567	2.08	2.08	1.00	589
27	20	2.58	2.32	0.90	556	2.40	2.16	0.90	583	2.23	2.00	0.90	616
27	22	2.73	2.13	0.78	578	2.55	1.99	0.78	610	2.38	1.85	0.78	632
27	24	2.88	1.90	0.66	600	2.70	1.78	0.66	627	2.55	1.68	0.66	654
27	26	3.03	1.63	0.54	621	2.85	1.54	0.54	649	2.68	1.44	0.54	676
28	18	2.45	2.45	1.00	534	2.25	2.25	1.00	567	2.08	2.08	1.00	589
28	20	2.58	2.42	0.94	556	2.40	2.26	0.94	583	2.23	2.09	0.94	616
28	22	2.73	2.23	0.82	578	2.55	2.09	0.82	610	2.38	1.95	0.82	632
28	24	2.88	2.01	0.70	600	2.70	1.89	0.70	627	2.55	1.79	0.70	654
28	26	3.03	1.75	0.58	621	2.85	1.65	0.58	649	2.68	1.55	0.58	676
29	18	2.45	2.45	1.00	534	2.25	2.25	1.00	567	2.08	2.08	1.00	589
29	20	2.58	2.52	0.98	556	2.40	2.35	0.98	583	2.23	2.18	0.98	616
29	22	2.73	2.34	0.86	578	2.55	2.19	0.86	610	2.38	2.04	0.86	632
29	24	2.88	2.13	0.74	600	2.70	2.00	0.74	627	2.55	1.89	0.74	654
29	26	3.03	1.88	0.62	621	2.85	1.77	0.62	649	2.68	1.66	0.62	676
30	18	2.45	2.45	1.00	534	2.25	2.25	1.00	567	2.08	2.08	1.00	589
30	20	2.58	2.58	1.00	556	2.40	2.40	1.00	583	2.23	2.23	1.00	616
30	22	2.73	2.45	0.90	578	2.55	2.30	0.90	610	2.38	2.14	0.90	632
30	24	2.88	2.24	0.78	600	2.70	2.11	0.78	627	2.55	1.99	0.78	654
30	26	3.03	2.00	0.66	621	2.85	1.88	0.66	649	2.68	1.77	0.66	676
31	18	2.45	2.45	1.00	534	2.25	2.25	1.00	567	2.08	2.08	1.00	589
31	20	2.58	2.58	1.00	556	2.40	2.40	1.00	583	2.23	2.23	1.00	616
31	22	2.73	2.56	0.94	578	2.55	2.40	0.94	610	2.38	2.23	0.94	632
31	24	2.88	2.36	0.82	600	2.70	2.21	0.82	627	2.55	2.09	0.82	654
31	26	3.03	2.12	0.70	621	2.85	2.00	0.70	649	2.68	1.87	0.70	676
32	18	2.45	2.45	1.00	534	2.25	2.25	1.00	567	2.08	2.08	1.00	589
32	20	2.58	2.58	1.00	556	2.40	2.40	1.00	583	2.23	2.23	1.00	616
32	22	2.73	2.67	0.98	578	2.55	2.50	0.98	610	2.38	2.33	0.98	632
32	24	2.88	2.47	0.86	600	2.70	2.32	0.86	627	2.55	2.19	0.86	654
32	26	3.03	2.24	0.74	621	2.85	2.11	0.74	649	2.68	1.98	0.74	676

**NOTE** Q : Total capacity (kW) SHF : Sensible heat factor DB : Dry-bulb temperature  
 SHC : Sensible heat capacity (kW) INPUT : Total power input (W) WB : Wet-bulb temperature

**PERFORMANCE DATA COOL operation at Rated frequency**  
**MUZ-GE35VA MUZ-GE35VAH**

CAPACITY: 3.5 kW SHF: 0.82 INPUT: 865 W

INDOOR DB (°C)	INDOOR WB (°C)	OUTDOOR DB (°C)															
		21				25				27				30			
		Q	SHC	SHF	INPUT	Q	SHC	SHF	INPUT	Q	SHC	SHF	INPUT	Q	SHC	SHF	INPUT
21	18	4.11	2.63	0.64	692	3.94	2.52	0.64	727	3.78	2.42	0.64	761	3.64	2.33	0.64	796
21	20	4.29	2.23	0.52	727	4.11	2.14	0.52	770	3.99	2.07	0.52	787	3.85	2.00	0.52	822
22	18	4.11	2.80	0.68	692	3.94	2.68	0.68	727	3.78	2.57	0.68	761	3.64	2.48	0.68	796
22	20	4.29	2.40	0.56	727	4.11	2.30	0.56	770	3.99	2.23	0.56	787	3.85	2.16	0.56	822
22	22	4.46	1.96	0.44	753	4.31	1.89	0.44	800	4.20	1.85	0.44	822	4.03	1.77	0.44	856
23	18	4.11	2.96	0.72	692	3.94	2.84	0.72	727	3.78	2.72	0.72	761	3.64	2.62	0.72	796
23	20	4.29	2.57	0.60	727	4.11	2.47	0.60	770	3.99	2.39	0.60	787	3.85	2.31	0.60	822
23	22	4.46	2.14	0.48	753	4.31	2.07	0.48	800	4.20	2.02	0.48	822	4.03	1.93	0.48	856
24	18	4.11	3.13	0.76	692	3.94	2.99	0.76	727	3.78	2.87	0.76	761	3.64	2.77	0.76	796
24	20	4.29	2.74	0.64	727	4.11	2.63	0.64	770	3.99	2.55	0.64	787	3.85	2.46	0.64	822
24	22	4.46	2.32	0.52	753	4.31	2.24	0.52	800	4.20	2.18	0.52	822	4.03	2.09	0.52	856
24	24	4.69	1.88	0.40	787	4.52	1.81	0.40	830	4.41	1.76	0.40	856	4.27	1.71	0.40	900
25	18	4.11	3.29	0.80	692	3.94	3.15	0.80	727	3.78	3.02	0.80	761	3.64	2.91	0.80	796
25	20	4.29	2.92	0.68	727	4.11	2.80	0.68	770	3.99	2.71	0.68	787	3.85	2.62	0.68	822
25	22	4.46	2.50	0.56	753	4.31	2.41	0.56	800	4.20	2.35	0.56	822	4.03	2.25	0.56	856
25	24	4.69	2.06	0.44	787	4.52	1.99	0.44	830	4.41	1.94	0.44	856	4.27	1.88	0.44	900
26	18	4.11	3.45	0.84	692	3.94	3.31	0.84	727	3.78	3.18	0.84	761	3.64	3.06	0.84	796
26	20	4.29	3.09	0.72	727	4.11	2.96	0.72	770	3.99	2.87	0.72	787	3.85	2.77	0.72	822
26	22	4.46	2.68	0.60	753	4.31	2.58	0.60	800	4.20	2.52	0.60	822	4.03	2.42	0.60	856
26	24	4.69	2.25	0.48	787	4.52	2.17	0.48	830	4.41	2.12	0.48	856	4.27	2.05	0.48	900
26	26	4.83	1.74	0.36	830	4.69	1.69	0.36	874	4.62	1.66	0.36	900	4.48	1.61	0.36	926
27	18	4.11	3.62	0.88	692	3.94	3.47	0.88	727	3.78	3.33	0.88	761	3.64	3.20	0.88	796
27	20	4.29	3.26	0.76	727	4.11	3.13	0.76	770	3.99	3.03	0.76	787	3.85	2.93	0.76	822
27	22	4.46	2.86	0.64	753	4.31	2.76	0.64	800	4.20	2.69	0.64	822	4.03	2.58	0.64	856
27	24	4.69	2.44	0.52	787	4.52	2.35	0.52	830	4.41	2.29	0.52	856	4.27	2.22	0.52	900
27	26	4.83	1.93	0.40	830	4.69	1.88	0.40	874	4.62	1.85	0.40	900	4.48	1.79	0.40	926
28	18	4.11	3.78	0.92	692	3.94	3.62	0.92	727	3.78	3.48	0.92	761	3.64	3.35	0.92	796
28	20	4.29	3.43	0.80	727	4.11	3.29	0.80	770	3.99	3.19	0.80	787	3.85	3.08	0.80	822
28	22	4.46	3.03	0.68	753	4.31	2.93	0.68	800	4.20	2.86	0.68	822	4.03	2.74	0.68	856
28	24	4.69	2.63	0.56	787	4.52	2.53	0.56	830	4.41	2.47	0.56	856	4.27	2.39	0.56	900
28	26	4.83	2.13	0.44	830	4.69	2.06	0.44	874	4.62	2.03	0.44	900	4.48	1.97	0.44	926
29	18	4.11	3.95	0.96	692	3.94	3.78	0.96	727	3.78	3.63	0.96	761	3.64	3.49	0.96	796
29	20	4.29	3.60	0.84	727	4.11	3.45	0.84	770	3.99	3.35	0.84	787	3.85	3.23	0.84	822
29	22	4.46	3.21	0.72	753	4.31	3.10	0.72	800	4.20	3.02	0.72	822	4.03	2.90	0.72	856
29	24	4.69	2.81	0.60	787	4.52	2.71	0.60	830	4.41	2.65	0.60	856	4.27	2.56	0.60	900
29	26	4.83	2.32	0.48	830	4.69	2.25	0.48	874	4.62	2.22	0.48	900	4.48	2.15	0.48	926
30	18	4.11	4.11	1.00	692	3.94	3.94	1.00	727	3.78	3.78	1.00	761	3.64	3.64	1.00	796
30	20	4.29	3.77	0.88	727	4.11	3.62	0.88	770	3.99	3.51	0.88	787	3.85	3.39	0.88	822
30	22	4.46	3.39	0.76	753	4.31	3.27	0.76	800	4.20	3.19	0.76	822	4.03	3.06	0.76	856
30	24	4.69	3.00	0.64	787	4.52	2.89	0.64	830	4.41	2.82	0.64	856	4.27	2.73	0.64	900
30	26	4.83	2.51	0.52	830	4.69	2.44	0.52	874	4.62	2.40	0.52	900	4.48	2.33	0.52	926
31	18	4.11	4.11	1.00	692	3.94	3.94	1.00	727	3.78	3.78	1.00	761	3.64	3.64	1.00	796
31	20	4.29	3.94	0.92	727	4.11	3.78	0.92	770	3.99	3.67	0.92	787	3.85	3.54	0.92	822
31	22	4.46	3.57	0.80	753	4.31	3.44	0.80	800	4.20	3.36	0.80	822	4.03	3.22	0.80	856
31	24	4.69	3.19	0.68	787	4.52	3.07	0.68	830	4.41	3.00	0.68	856	4.27	2.90	0.68	900
31	26	4.83	2.70	0.56	830	4.69	2.63	0.56	874	4.62	2.59	0.56	900	4.48	2.51	0.56	926
32	18	4.11	4.11	1.00	692	3.94	3.94	1.00	727	3.78	3.78	1.00	761	3.64	3.64	1.00	796
32	20	4.29	4.12	0.96	727	4.11	3.95	0.96	770	3.99	3.83	0.96	787	3.85	3.70	0.96	822
32	22	4.46	3.75	0.84	753	4.31	3.62	0.84	800	4.20	3.53	0.84	822	4.03	3.38	0.84	856
32	24	4.69	3.38	0.72	787	4.52	3.25	0.72	830	4.41	3.18	0.72	856	4.27	3.07	0.72	900
32	26	4.83	2.90	0.60	830	4.69	2.81	0.60	874	4.62	2.77	0.60	900	4.48	2.69	0.60	926

**NOTE** Q : Total capacity (kW) SHF : Sensible heat factor DB : Dry-bulb temperature  
 SHC : Sensible heat capacity (kW) INPUT : Total power input (W) WB : Wet-bulb temperature

**PERFORMANCE DATA COOL operation at Rated frequency**

**MUZ-GE35VA MUZ-GE35VAH**

CAPACITY: 3.5 kW

SHF: 0.82

INPUT: 865 W

INDOOR DB (°C)	INDOOR WB (°C)	OUTDOOR DB (°C)											
		35				40				46			
		Q	SHC	SHF	INPUT	Q	SHC	SHF	INPUT	Q	SHC	SHF	INPUT
21	18	3.43	2.20	0.64	848	3.15	2.02	0.64	900	2.91	1.86	0.64	934
21	20	3.61	1.87	0.52	882	3.36	1.75	0.52	926	3.12	1.62	0.52	977
22	18	3.43	2.33	0.68	848	3.15	2.14	0.68	900	2.91	1.98	0.68	934
22	20	3.61	2.02	0.56	882	3.36	1.88	0.56	926	3.12	1.74	0.56	977
22	22	3.82	1.68	0.44	917	3.57	1.57	0.44	969	3.33	1.46	0.44	1003
23	18	3.43	2.47	0.72	848	3.15	2.27	0.72	900	2.91	2.09	0.72	934
23	20	3.61	2.16	0.60	882	3.36	2.02	0.60	926	3.12	1.87	0.60	977
23	22	3.82	1.83	0.48	917	3.57	1.71	0.48	969	3.33	1.60	0.48	1003
24	18	3.43	2.61	0.76	848	3.15	2.39	0.76	900	2.91	2.21	0.76	934
24	20	3.61	2.31	0.64	882	3.36	2.15	0.64	926	3.12	1.99	0.64	977
24	22	3.82	1.98	0.52	917	3.57	1.86	0.52	969	3.33	1.73	0.52	1003
24	24	4.03	1.61	0.40	952	3.78	1.51	0.40	995	3.57	1.43	0.40	1038
25	18	3.43	2.74	0.80	848	3.15	2.52	0.80	900	2.91	2.32	0.8	934
25	20	3.61	2.45	0.68	882	3.36	2.28	0.68	926	3.12	2.12	0.68	977
25	22	3.82	2.14	0.56	917	3.57	2.00	0.56	969	3.33	1.86	0.56	1003
25	24	4.03	1.77	0.44	952	3.78	1.66	0.44	995	3.57	1.57	0.44	1038
26	18	3.43	2.88	0.84	848	3.15	2.65	0.84	900	2.91	2.44	0.84	934
26	20	3.61	2.60	0.72	882	3.36	2.42	0.72	926	3.12	2.24	0.72	977
26	22	3.82	2.29	0.60	917	3.57	2.14	0.60	969	3.33	2.00	0.60	1003
26	24	4.03	1.93	0.48	952	3.78	1.81	0.48	995	3.57	1.71	0.48	1038
26	26	4.24	1.52	0.36	986	3.99	1.44	0.36	1029	3.75	1.35	0.36	1073
27	18	3.43	3.02	0.88	848	3.15	2.77	0.88	900	2.91	2.56	0.88	934
27	20	3.61	2.74	0.76	882	3.36	2.55	0.76	926	3.12	2.37	0.76	977
27	22	3.82	2.44	0.64	917	3.57	2.28	0.64	969	3.33	2.13	0.64	1003
27	24	4.03	2.09	0.52	952	3.78	1.97	0.52	995	3.57	1.86	0.52	1038
27	26	4.24	1.69	0.40	986	3.99	1.60	0.40	1029	3.75	1.50	0.40	1073
28	18	3.43	3.16	0.92	848	3.15	2.90	0.92	900	2.91	2.67	0.92	934
28	20	3.61	2.88	0.80	882	3.36	2.69	0.80	926	3.12	2.49	0.80	977
28	22	3.82	2.59	0.68	917	3.57	2.43	0.68	969	3.33	2.26	0.68	1003
28	24	4.03	2.25	0.56	952	3.78	2.12	0.56	995	3.57	2.00	0.56	1038
28	26	4.24	1.86	0.44	986	3.99	1.76	0.44	1029	3.75	1.65	0.44	1073
29	18	3.43	3.29	0.96	848	3.15	3.02	0.96	900	2.91	2.79	0.96	934
29	20	3.61	3.03	0.84	882	3.36	2.82	0.84	926	3.12	2.62	0.84	977
29	22	3.82	2.75	0.72	917	3.57	2.57	0.72	969	3.33	2.39	0.72	1003
29	24	4.03	2.42	0.60	952	3.78	2.27	0.60	995	3.57	2.14	0.60	1038
29	26	4.24	2.03	0.48	986	3.99	1.92	0.48	1029	3.75	1.80	0.48	1073
30	18	3.43	3.43	1.00	848	3.15	3.15	1.00	900	2.91	2.91	1.00	934
30	20	3.61	3.17	0.88	882	3.36	2.96	0.88	926	3.12	2.74	0.88	977
30	22	3.82	2.90	0.76	917	3.57	2.71	0.76	969	3.33	2.53	0.76	1003
30	24	4.03	2.58	0.64	952	3.78	2.42	0.64	995	3.57	2.28	0.64	1038
30	26	4.24	2.20	0.52	986	3.99	2.07	0.52	1029	3.75	1.95	0.52	1073
31	18	3.43	3.43	1.00	848	3.15	3.15	1.00	900	2.91	2.91	1.00	934
31	20	3.61	3.32	0.92	882	3.36	3.09	0.92	926	3.12	2.87	0.92	977
31	22	3.82	3.05	0.80	917	3.57	2.86	0.80	969	3.33	2.66	0.80	1003
31	24	4.03	2.74	0.68	952	3.78	2.57	0.68	995	3.57	2.43	0.68	1038
31	26	4.24	2.37	0.56	986	3.99	2.23	0.56	1029	3.75	2.10	0.56	1073
32	18	3.43	3.43	1.00	848	3.15	3.15	1.00	900	2.91	2.91	1.00	934
32	20	3.61	3.46	0.96	882	3.36	3.23	0.96	926	3.12	2.99	0.96	977
32	22	3.82	3.20	0.84	917	3.57	3.00	0.84	969	3.33	2.79	0.84	1003
32	24	4.03	2.90	0.72	952	3.78	2.72	0.72	995	3.57	2.57	0.72	1038
32	26	4.24	2.54	0.60	986	3.99	2.39	0.60	1029	3.75	2.25	0.60	1073

**NOTE** Q : Total capacity (kW) SHF : Sensible heat factor DB : Dry-bulb temperature  
 SHC : Sensible heat capacity (kW) INPUT : Total power input (W) WB : Wet-bulb temperature

**PERFORMANCE DATA COOL operation at Rated frequency**  
**MUZ-GE42VA MUZ-GE42VAH**

CAPACITY: 4.2 kW SHF: 0.77 INPUT: 1215 W

INDOOR DB (°C)	INDOOR WB (°C)	OUTDOOR DB (°C)															
		21				25				27				30			
		Q	SHC	SHF	INPUT	Q	SHC	SHF	INPUT	Q	SHC	SHF	INPUT	Q	SHC	SHF	INPUT
21	18	4.94	2.91	0.59	972	4.73	2.79	0.59	1021	4.54	2.68	0.59	1069	4.37	2.58	0.59	1118
21	20	5.15	2.42	0.47	1021	4.94	2.32	0.47	1081	4.79	2.25	0.47	1106	4.62	2.17	0.47	1154
22	18	4.94	3.11	0.63	972	4.73	2.98	0.63	1021	4.54	2.86	0.63	1069	4.37	2.75	0.63	1118
22	20	5.15	2.62	0.51	1021	4.94	2.52	0.51	1081	4.79	2.44	0.51	1106	4.62	2.36	0.51	1154
22	22	5.36	2.09	0.39	1057	5.17	2.01	0.39	1124	5.04	1.97	0.39	1154	4.83	1.88	0.39	1203
23	18	4.94	3.31	0.67	972	4.73	3.17	0.67	1021	4.54	3.04	0.67	1069	4.37	2.93	0.67	1118
23	20	5.15	2.83	0.55	1021	4.94	2.71	0.55	1081	4.79	2.63	0.55	1106	4.62	2.54	0.55	1154
23	22	5.36	2.30	0.43	1057	5.17	2.22	0.43	1124	5.04	2.17	0.43	1154	4.83	2.08	0.43	1203
24	18	4.94	3.50	0.71	972	4.73	3.35	0.71	1021	4.54	3.22	0.71	1069	4.37	3.10	0.71	1118
24	20	5.15	3.04	0.59	1021	4.94	2.91	0.59	1081	4.79	2.82	0.59	1106	4.62	2.73	0.59	1154
24	22	5.36	2.52	0.47	1057	5.17	2.43	0.47	1124	5.04	2.37	0.47	1154	4.83	2.27	0.47	1203
24	24	5.63	1.97	0.35	1106	5.42	1.90	0.35	1166	5.29	1.85	0.35	1203	5.12	1.79	0.35	1264
25	18	4.94	3.70	0.75	972	4.73	3.54	0.75	1021	4.54	3.40	0.75	1069	4.37	3.28	0.75	1118
25	20	5.15	3.24	0.63	1021	4.94	3.11	0.63	1081	4.79	3.02	0.63	1106	4.62	2.91	0.63	1154
25	22	5.36	2.73	0.51	1057	5.17	2.63	0.51	1124	5.04	2.57	0.51	1154	4.83	2.46	0.51	1203
25	24	5.63	2.19	0.39	1106	5.42	2.11	0.39	1166	5.29	2.06	0.39	1203	5.12	2.00	0.39	1264
26	18	4.94	3.90	0.79	972	4.73	3.73	0.79	1021	4.54	3.58	0.79	1069	4.37	3.45	0.79	1118
26	20	5.15	3.45	0.67	1021	4.94	3.31	0.67	1081	4.79	3.21	0.67	1106	4.62	3.10	0.67	1154
26	22	5.36	2.95	0.55	1057	5.17	2.84	0.55	1124	5.04	2.77	0.55	1154	4.83	2.66	0.55	1203
26	24	5.63	2.42	0.43	1106	5.42	2.33	0.43	1166	5.29	2.28	0.43	1203	5.12	2.20	0.43	1264
26	26	5.80	1.80	0.31	1166	5.63	1.74	0.31	1227	5.54	1.72	0.31	1264	5.38	1.67	0.31	1300
27	18	4.94	4.10	0.83	972	4.73	3.92	0.83	1021	4.54	3.76	0.83	1069	4.37	3.63	0.83	1118
27	20	5.15	3.65	0.71	1021	4.94	3.50	0.71	1081	4.79	3.40	0.71	1106	4.62	3.28	0.71	1154
27	22	5.36	3.16	0.59	1057	5.17	3.05	0.59	1124	5.04	2.97	0.59	1154	4.83	2.85	0.59	1203
27	24	5.63	2.65	0.47	1106	5.42	2.55	0.47	1166	5.29	2.49	0.47	1203	5.12	2.41	0.47	1264
27	26	5.80	2.03	0.35	1166	5.63	1.97	0.35	1227	5.54	1.94	0.35	1264	5.38	1.88	0.35	1300
28	18	4.94	4.29	0.87	972	4.73	4.11	0.87	1021	4.54	3.95	0.87	1069	4.37	3.80	0.87	1118
28	20	5.15	3.86	0.75	1021	4.94	3.70	0.75	1081	4.79	3.59	0.75	1106	4.62	3.47	0.75	1154
28	22	5.36	3.37	0.63	1057	5.17	3.25	0.63	1124	5.04	3.18	0.63	1154	4.83	3.04	0.63	1203
28	24	5.63	2.87	0.51	1106	5.42	2.76	0.51	1166	5.29	2.70	0.51	1203	5.12	2.61	0.51	1264
28	26	5.80	2.26	0.39	1166	5.63	2.19	0.39	1227	5.54	2.16	0.39	1264	5.38	2.10	0.39	1300
29	18	4.94	4.49	0.91	972	4.73	4.30	0.91	1021	4.54	4.13	0.91	1069	4.37	3.97	0.91	1118
29	20	5.15	4.06	0.79	1021	4.94	3.90	0.79	1081	4.79	3.78	0.79	1106	4.62	3.65	0.79	1154
29	22	5.36	3.59	0.67	1057	5.17	3.46	0.67	1124	5.04	3.38	0.67	1154	4.83	3.24	0.67	1203
29	24	5.63	3.10	0.55	1106	5.42	2.98	0.55	1166	5.29	2.91	0.55	1203	5.12	2.82	0.55	1264
29	26	5.80	2.49	0.43	1166	5.63	2.42	0.43	1227	5.54	2.38	0.43	1264	5.38	2.31	0.43	1300
30	18	4.94	4.69	0.95	972	4.73	4.49	0.95	1021	4.54	4.31	0.95	1069	4.37	4.15	0.95	1118
30	20	5.15	4.27	0.83	1021	4.94	4.10	0.83	1081	4.79	3.97	0.83	1106	4.62	3.83	0.83	1154
30	22	5.36	3.80	0.71	1057	5.17	3.67	0.71	1124	5.04	3.58	0.71	1154	4.83	3.43	0.71	1203
30	24	5.63	3.32	0.59	1106	5.42	3.20	0.59	1166	5.29	3.12	0.59	1203	5.12	3.02	0.59	1264
30	26	5.80	2.72	0.47	1166	5.63	2.65	0.47	1227	5.54	2.61	0.47	1264	5.38	2.53	0.47	1300
31	18	4.94	4.89	0.99	972	4.73	4.68	0.99	1021	4.54	4.49	0.99	1069	4.37	4.32	0.99	1118
31	20	5.15	4.48	0.87	1021	4.94	4.29	0.87	1081	4.79	4.17	0.87	1106	4.62	4.02	0.87	1154
31	22	5.36	4.02	0.75	1057	5.17	3.87	0.75	1124	5.04	3.78	0.75	1154	4.83	3.62	0.75	1203
31	24	5.63	3.55	0.63	1106	5.42	3.41	0.63	1166	5.29	3.33	0.63	1203	5.12	3.23	0.63	1264
31	26	5.80	2.96	0.51	1166	5.63	2.87	0.51	1227	5.54	2.83	0.51	1264	5.38	2.74	0.51	1300
32	18	4.94	4.94	1.00	972	4.73	4.73	1.00	1021	4.54	4.54	1.00	1069	4.37	4.37	1.00	1118
32	20	5.15	4.68	0.91	1021	4.94	4.49	0.91	1081	4.79	4.36	0.91	1106	4.62	4.20	0.91	1154
32	22	5.36	4.23	0.79	1057	5.17	4.08	0.79	1124	5.04	3.98	0.79	1154	4.83	3.82	0.79	1203
32	24	5.63	3.77	0.67	1106	5.42	3.63	0.67	1166	5.29	3.55	0.67	1203	5.12	3.43	0.67	1264
32	26	5.80	3.19	0.55	1166	5.63	3.10	0.55	1227	5.54	3.05	0.55	1264	5.38	2.96	0.55	1300

**NOTE** Q : Total capacity (kW) SHF : Sensible heat factor DB : Dry-bulb temperature  
 SHC : Sensible heat capacity (kW) INPUT : Total power input (W) WB : Wet-bulb temperature

**PERFORMANCE DATA COOL operation at Rated frequency**

**MUZ-GE42VA MUZ-GE42VAH**

CAPACITY: 4.2 kW

SHF: 0.77

INPUT: 1215 W

INDOOR DB (°C)	INDOOR WB (°C)	OUTDOOR DB (°C)											
		35				40				46			
		Q	SHC	SHF	INPUT	Q	SHC	SHF	INPUT	Q	SHC	SHF	INPUT
21	18	4.12	2.43	0.59	1191	3.78	2.23	0.59	1264	3.49	2.06	0.59	1312
21	20	4.33	2.03	0.47	1239	4.03	1.90	0.47	1300	3.74	1.76	0.47	1373
22	18	4.12	2.59	0.63	1191	3.78	2.38	0.63	1264	3.49	2.20	0.63	1312
22	20	4.33	2.21	0.51	1239	4.03	2.06	0.51	1300	3.74	1.91	0.51	1373
22	22	4.58	1.79	0.39	1288	4.28	1.67	0.39	1361	3.99	1.56	0.39	1409
23	18	4.12	2.76	0.67	1191	3.78	2.53	0.67	1264	3.49	2.34	0.67	1312
23	20	4.33	2.38	0.55	1239	4.03	2.22	0.55	1300	3.74	2.06	0.55	1373
23	22	4.58	1.97	0.43	1288	4.28	1.84	0.43	1361	3.99	1.72	0.43	1409
24	18	4.12	2.92	0.71	1191	3.78	2.68	0.71	1264	3.49	2.48	0.71	1312
24	20	4.33	2.55	0.59	1239	4.03	2.38	0.59	1300	3.74	2.21	0.59	1373
24	22	4.58	2.15	0.47	1288	4.28	2.01	0.47	1361	3.99	1.88	0.47	1409
24	24	4.83	1.69	0.35	1337	4.54	1.59	0.35	1397	4.28	1.50	0.35	1458
25	18	4.12	3.09	0.75	1191	3.78	2.84	0.75	1264	3.49	2.61	0.75	1312
25	20	4.33	2.73	0.63	1239	4.03	2.54	0.63	1300	3.74	2.35	0.63	1373
25	22	4.58	2.33	0.51	1288	4.28	2.18	0.51	1361	3.99	2.03	0.51	1409
25	24	4.83	1.88	0.39	1337	4.54	1.77	0.39	1397	4.28	1.67	0.39	1458
26	18	4.12	3.25	0.79	1191	3.78	2.99	0.79	1264	3.49	2.75	0.79	1312
26	20	4.33	2.90	0.67	1239	4.03	2.70	0.67	1300	3.74	2.50	0.67	1373
26	22	4.58	2.52	0.55	1288	4.28	2.36	0.55	1361	3.99	2.19	0.55	1409
26	24	4.83	2.08	0.43	1337	4.54	1.95	0.43	1397	4.28	1.84	0.43	1458
26	26	5.08	1.58	0.31	1385	4.79	1.48	0.31	1446	4.49	1.39	0.31	1507
27	18	4.12	3.42	0.83	1191	3.78	3.14	0.83	1264	3.49	2.89	0.83	1312
27	20	4.33	3.07	0.71	1239	4.03	2.86	0.71	1300	3.74	2.65	0.71	1373
27	22	4.58	2.70	0.59	1288	4.28	2.53	0.59	1361	3.99	2.35	0.59	1409
27	24	4.83	2.27	0.47	1337	4.54	2.13	0.47	1397	4.28	2.01	0.47	1458
27	26	5.08	1.78	0.35	1385	4.79	1.68	0.35	1446	4.49	1.57	0.35	1507
28	18	4.12	3.58	0.87	1191	3.78	3.29	0.87	1264	3.49	3.03	0.87	1312
28	20	4.33	3.24	0.75	1239	4.03	3.02	0.75	1300	3.74	2.80	0.75	1373
28	22	4.58	2.88	0.63	1288	4.28	2.70	0.63	1361	3.99	2.51	0.63	1409
28	24	4.83	2.46	0.51	1337	4.54	2.31	0.51	1397	4.28	2.18	0.51	1458
28	26	5.08	1.98	0.39	1385	4.79	1.87	0.39	1446	4.49	1.75	0.39	1507
29	18	4.12	3.75	0.91	1191	3.78	3.44	0.91	1264	3.49	3.17	0.91	1312
29	20	4.33	3.42	0.79	1239	4.03	3.19	0.79	1300	3.74	2.95	0.79	1373
29	22	4.58	3.07	0.67	1288	4.28	2.87	0.67	1361	3.99	2.67	0.67	1409
29	24	4.83	2.66	0.55	1337	4.54	2.49	0.55	1397	4.28	2.36	0.55	1458
29	26	5.08	2.19	0.43	1385	4.79	2.06	0.43	1446	4.49	1.93	0.43	1507
30	18	4.12	3.91	0.95	1191	3.78	3.59	0.95	1264	3.49	3.31	0.95	1312
30	20	4.33	3.59	0.83	1239	4.03	3.35	0.83	1300	3.74	3.10	0.83	1373
30	22	4.58	3.25	0.71	1288	4.28	3.04	0.71	1361	3.99	2.83	0.71	1409
30	24	4.83	2.85	0.59	1337	4.54	2.68	0.59	1397	4.28	2.53	0.59	1458
30	26	5.08	2.39	0.47	1385	4.79	2.25	0.47	1446	4.49	2.11	0.47	1507
31	18	4.12	4.07	0.99	1191	3.78	3.74	0.99	1264	3.49	3.45	0.99	1312
31	20	4.33	3.76	0.87	1239	4.03	3.51	0.87	1300	3.74	3.25	0.87	1373
31	22	4.58	3.43	0.75	1288	4.28	3.21	0.75	1361	3.99	2.99	0.75	1409
31	24	4.83	3.04	0.63	1337	4.54	2.86	0.63	1397	4.28	2.70	0.63	1458
31	26	5.08	2.59	0.51	1385	4.79	2.44	0.51	1446	4.49	2.29	0.51	1507
32	18	4.12	4.12	1.00	1191	3.78	3.78	1.00	1264	3.49	3.49	1.00	1312
32	20	4.33	3.94	0.91	1239	4.03	3.67	0.91	1300	3.74	3.40	0.91	1373
32	22	4.58	3.62	0.79	1288	4.28	3.38	0.79	1361	3.99	3.15	0.79	1409
32	24	4.83	3.24	0.67	1337	4.54	3.04	0.67	1397	4.28	2.87	0.67	1458
32	26	5.08	2.80	0.55	1385	4.79	2.63	0.55	1446	4.49	2.47	0.55	1507

**NOTE** Q : Total capacity (kW) SHF : Sensible heat factor DB : Dry-bulb temperature  
 SHC : Sensible heat capacity (kW) INPUT : Total power input (W) WB : Wet-bulb temperature



**PERFORMANCE DATA COOL operation at Rated frequency**  
**MUZ-GE50VA MUZ-GE50VAH**

CAPACITY: 5.0 kW SHF: 0.76 INPUT: 1515 W

INDOOR DB (°C)	INDOOR WB (°C)	OUTDOOR DB (°C)															
		21				25				27				30			
		Q	SHC	SHF	INPUT	Q	SHC	SHF	INPUT	Q	SHC	SHF	INPUT	Q	SHC	SHF	INPUT
21	18	5.88	3.41	0.58	1212	5.63	3.26	0.58	1273	5.40	3.13	0.58	1333	5.20	3.02	0.58	1394
21	20	6.13	2.82	0.46	1273	5.88	2.70	0.46	1348	5.70	2.62	0.46	1379	5.50	2.53	0.46	1439
22	18	5.88	3.64	0.62	1212	5.63	3.49	0.62	1273	5.40	3.35	0.62	1333	5.20	3.22	0.62	1394
22	20	6.13	3.06	0.50	1273	5.88	2.94	0.50	1348	5.70	2.85	0.50	1379	5.50	2.75	0.50	1439
22	22	6.38	2.42	0.38	1318	6.15	2.34	0.38	1401	6.00	2.28	0.38	1439	5.75	2.19	0.38	1500
23	18	5.88	3.88	0.66	1212	5.63	3.71	0.66	1273	5.40	3.56	0.66	1333	5.20	3.43	0.66	1394
23	20	6.13	3.31	0.54	1273	5.88	3.17	0.54	1348	5.70	3.08	0.54	1379	5.50	2.97	0.54	1439
23	22	6.38	2.68	0.42	1318	6.15	2.58	0.42	1401	6.00	2.52	0.42	1439	5.75	2.42	0.42	1500
24	18	5.88	4.11	0.70	1212	5.63	3.94	0.70	1273	5.40	3.78	0.70	1333	5.20	3.64	0.70	1394
24	20	6.13	3.55	0.58	1273	5.88	3.41	0.58	1348	5.70	3.31	0.58	1379	5.50	3.19	0.58	1439
24	22	6.38	2.93	0.46	1318	6.15	2.83	0.46	1401	6.00	2.76	0.46	1439	5.75	2.65	0.46	1500
24	24	6.70	2.28	0.34	1379	6.45	2.19	0.34	1454	6.30	2.14	0.34	1500	6.10	2.07	0.34	1576
25	18	5.88	4.35	0.74	1212	5.63	4.16	0.74	1273	5.40	4.00	0.74	1333	5.20	3.85	0.74	1394
25	20	6.13	3.80	0.62	1273	5.88	3.64	0.62	1348	5.70	3.53	0.62	1379	5.50	3.41	0.62	1439
25	22	6.38	3.19	0.50	1318	6.15	3.08	0.50	1401	6.00	3.00	0.50	1439	5.75	2.88	0.50	1500
25	24	6.70	2.55	0.38	1379	6.45	2.45	0.38	1454	6.30	2.39	0.38	1500	6.10	2.32	0.38	1576
26	18	5.88	4.58	0.78	1212	5.63	4.39	0.78	1273	5.40	4.21	0.78	1333	5.20	4.06	0.78	1394
26	20	6.13	4.04	0.66	1273	5.88	3.88	0.66	1348	5.70	3.76	0.66	1379	5.50	3.63	0.66	1439
26	22	6.38	3.44	0.54	1318	6.15	3.32	0.54	1401	6.00	3.24	0.54	1439	5.75	3.11	0.54	1500
26	24	6.70	2.81	0.42	1379	6.45	2.71	0.42	1454	6.30	2.65	0.42	1500	6.10	2.56	0.42	1576
26	26	6.90	2.07	0.30	1454	6.70	2.01	0.30	1530	6.60	1.98	0.30	1576	6.40	1.92	0.30	1621
27	18	5.88	4.82	0.82	1212	5.63	4.61	0.82	1273	5.40	4.43	0.82	1333	5.20	4.26	0.82	1394
27	20	6.13	4.29	0.70	1273	5.88	4.11	0.70	1348	5.70	3.99	0.70	1379	5.50	3.85	0.70	1439
27	22	6.38	3.70	0.58	1318	6.15	3.57	0.58	1401	6.00	3.48	0.58	1439	5.75	3.34	0.58	1500
27	24	6.70	3.08	0.46	1379	6.45	2.97	0.46	1454	6.30	2.90	0.46	1500	6.10	2.81	0.46	1576
27	26	6.90	2.35	0.34	1454	6.70	2.28	0.34	1530	6.60	2.24	0.34	1576	6.40	2.18	0.34	1621
28	18	5.88	5.05	0.86	1212	5.63	4.84	0.86	1273	5.40	4.64	0.86	1333	5.20	4.47	0.86	1394
28	20	6.13	4.53	0.74	1273	5.88	4.35	0.74	1348	5.70	4.22	0.74	1379	5.50	4.07	0.74	1439
28	22	6.38	3.95	0.62	1318	6.15	3.81	0.62	1401	6.00	3.72	0.62	1439	5.75	3.57	0.62	1500
28	24	6.70	3.35	0.50	1379	6.45	3.23	0.50	1454	6.30	3.15	0.50	1500	6.10	3.05	0.50	1576
28	26	6.90	2.62	0.38	1454	6.70	2.55	0.38	1530	6.60	2.51	0.38	1576	6.40	2.43	0.38	1621
29	18	5.88	5.29	0.90	1212	5.63	5.06	0.90	1273	5.40	4.86	0.90	1333	5.20	4.68	0.90	1394
29	20	6.13	4.78	0.78	1273	5.88	4.58	0.78	1348	5.70	4.45	0.78	1379	5.50	4.29	0.78	1439
29	22	6.38	4.21	0.66	1318	6.15	4.06	0.66	1401	6.00	3.96	0.66	1439	5.75	3.80	0.66	1500
29	24	6.70	3.62	0.54	1379	6.45	3.48	0.54	1454	6.30	3.40	0.54	1500	6.10	3.29	0.54	1576
29	26	6.90	2.90	0.42	1454	6.70	2.81	0.42	1530	6.60	2.77	0.42	1576	6.40	2.69	0.42	1621
30	18	5.88	5.52	0.94	1212	5.63	5.29	0.94	1273	5.40	5.08	0.94	1333	5.20	4.89	0.94	1394
30	20	6.13	5.02	0.82	1273	5.88	4.82	0.82	1348	5.70	4.67	0.82	1379	5.50	4.51	0.82	1439
30	22	6.38	4.46	0.70	1318	6.15	4.31	0.70	1401	6.00	4.20	0.70	1439	5.75	4.03	0.70	1500
30	24	6.70	3.89	0.58	1379	6.45	3.74	0.58	1454	6.30	3.65	0.58	1500	6.10	3.54	0.58	1576
30	26	6.90	3.17	0.46	1454	6.70	3.08	0.46	1530	6.60	3.04	0.46	1576	6.40	2.94	0.46	1621
31	18	5.88	5.76	0.98	1212	5.63	5.51	0.98	1273	5.40	5.29	0.98	1333	5.20	5.10	0.98	1394
31	20	6.13	5.27	0.86	1273	5.88	5.05	0.86	1348	5.70	4.90	0.86	1379	5.50	4.73	0.86	1439
31	22	6.38	4.72	0.74	1318	6.15	4.55	0.74	1401	6.00	4.44	0.74	1439	5.75	4.26	0.74	1500
31	24	6.70	4.15	0.62	1379	6.45	4.00	0.62	1454	6.30	3.91	0.62	1500	6.10	3.78	0.62	1576
31	26	6.90	3.45	0.50	1454	6.70	3.35	0.50	1530	6.60	3.30	0.50	1576	6.40	3.20	0.50	1621
32	18	5.88	5.88	1.00	1212	5.63	5.63	1.00	1273	5.40	5.40	1.00	1333	5.20	5.20	1.00	1394
32	20	6.13	5.51	0.90	1273	5.88	5.29	0.90	1348	5.70	5.13	0.90	1379	5.50	4.95	0.90	1439
32	22	6.38	4.97	0.78	1318	6.15	4.80	0.78	1401	6.00	4.68	0.78	1439	5.75	4.49	0.78	1500
32	24	6.70	4.42	0.66	1379	6.45	4.26	0.66	1454	6.30	4.16	0.66	1500	6.10	4.03	0.66	1576
32	26	6.90	3.73	0.54	1454	6.70	3.62	0.54	1530	6.60	3.56	0.54	1576	6.40	3.46	0.54	1621

**NOTE** Q : Total capacity (kW) SHF : Sensible heat factor DB : Dry-bulb temperature  
 SHC : Sensible heat capacity (kW) INPUT : Total power input (W) WB : Wet-bulb temperature

**PERFORMANCE DATA COOL operation at Rated frequency**

**MUZ-GE50VA MUZ-GE50VAH**

CAPACITY: 5.0 kW

SHF: 0.76

INPUT: 1515 W

INDOOR DB (°C)	INDOOR WB (°C)	OUTDOOR DB (°C)											
		35				40				46			
		Q	SHC	SHF	INPUT	Q	SHC	SHF	INPUT	Q	SHC	SHF	INPUT
21	18	4.90	2.84	0.58	1485	4.50	2.61	0.58	1576	4.15	2.41	0.58	1636
21	20	5.15	2.37	0.46	1545	4.80	2.21	0.46	1621	4.45	2.05	0.46	1712
22	18	4.90	3.04	0.62	1485	4.50	2.79	0.62	1576	4.15	2.57	0.62	1636
22	20	5.15	2.58	0.50	1545	4.80	2.40	0.50	1621	4.45	2.23	0.50	1712
22	22	5.45	2.07	0.38	1606	5.10	1.94	0.38	1697	4.75	1.81	0.38	1757
23	18	4.90	3.23	0.66	1485	4.50	2.97	0.66	1576	4.15	2.74	0.66	1636
23	20	5.15	2.78	0.54	1545	4.80	2.59	0.54	1621	4.45	2.40	0.54	1712
23	22	5.45	2.29	0.42	1606	5.10	2.14	0.42	1697	4.75	2.00	0.42	1757
24	18	4.90	3.43	0.70	1485	4.50	3.15	0.70	1576	4.15	2.91	0.70	1636
24	20	5.15	2.99	0.58	1545	4.80	2.78	0.58	1621	4.45	2.58	0.58	1712
24	22	5.45	2.51	0.46	1606	5.10	2.35	0.46	1697	4.75	2.19	0.46	1757
24	24	5.75	1.96	0.34	1667	5.40	1.84	0.34	1742	5.10	1.73	0.34	1818
25	18	4.90	3.63	0.74	1485	4.50	3.33	0.74	1576	4.15	3.07	0.74	1636
25	20	5.15	3.19	0.62	1545	4.80	2.98	0.62	1621	4.45	2.76	0.62	1712
25	22	5.45	2.73	0.50	1606	5.10	2.55	0.50	1697	4.75	2.38	0.50	1757
25	24	5.75	2.19	0.38	1667	5.40	2.05	0.38	1742	5.10	1.94	0.38	1818
26	18	4.90	3.82	0.78	1485	4.50	3.51	0.78	1576	4.15	3.24	0.78	1636
26	20	5.15	3.40	0.66	1545	4.80	3.17	0.66	1621	4.45	2.94	0.66	1712
26	22	5.45	2.94	0.54	1606	5.10	2.75	0.54	1697	4.75	2.57	0.54	1757
26	24	5.75	2.42	0.42	1667	5.40	2.27	0.42	1742	5.10	2.14	0.42	1818
26	26	6.05	1.82	0.30	1727	5.70	1.71	0.30	1803	5.35	1.61	0.30	1879
27	18	4.90	4.02	0.82	1485	4.50	3.69	0.82	1576	4.15	3.40	0.82	1636
27	20	5.15	3.61	0.70	1545	4.80	3.36	0.70	1621	4.45	3.12	0.70	1712
27	22	5.45	3.16	0.58	1606	5.10	2.96	0.58	1697	4.75	2.76	0.58	1757
27	24	5.75	2.65	0.46	1667	5.40	2.48	0.46	1742	5.10	2.35	0.46	1818
27	26	6.05	2.06	0.34	1727	5.70	1.94	0.34	1803	5.35	1.82	0.34	1879
28	18	4.90	4.21	0.86	1485	4.50	3.87	0.86	1576	4.15	3.57	0.86	1636
28	20	5.15	3.81	0.74	1545	4.80	3.55	0.74	1621	4.45	3.29	0.74	1712
28	22	5.45	3.38	0.62	1606	5.10	3.16	0.62	1697	4.75	2.95	0.62	1757
28	24	5.75	2.88	0.50	1667	5.40	2.70	0.50	1742	5.10	2.55	0.50	1818
28	26	6.05	2.30	0.38	1727	5.70	2.17	0.38	1803	5.35	2.03	0.38	1879
29	18	4.90	4.41	0.90	1485	4.50	4.05	0.90	1576	4.15	3.74	0.90	1636
29	20	5.15	4.02	0.78	1545	4.80	3.74	0.78	1621	4.45	3.47	0.78	1712
29	22	5.45	3.60	0.66	1606	5.10	3.37	0.66	1697	4.75	3.14	0.66	1757
29	24	5.75	3.11	0.54	1667	5.40	2.92	0.54	1742	5.10	2.75	0.54	1818
29	26	6.05	2.54	0.42	1727	5.70	2.39	0.42	1803	5.35	2.25	0.42	1879
30	18	4.90	4.61	0.94	1485	4.50	4.23	0.94	1576	4.15	3.90	0.94	1636
30	20	5.15	4.22	0.82	1545	4.80	3.94	0.82	1621	4.45	3.65	0.82	1712
30	22	5.45	3.82	0.70	1606	5.10	3.57	0.70	1697	4.75	3.33	0.70	1757
30	24	5.75	3.34	0.58	1667	5.40	3.13	0.58	1742	5.10	2.96	0.58	1818
30	26	6.05	2.78	0.46	1727	5.70	2.62	0.46	1803	5.35	2.46	0.46	1879
31	18	4.90	4.80	0.98	1485	4.50	4.41	0.98	1576	4.15	4.07	0.98	1636
31	20	5.15	4.43	0.86	1545	4.80	4.13	0.86	1621	4.45	3.83	0.86	1712
31	22	5.45	4.03	0.74	1606	5.10	3.77	0.74	1697	4.75	3.52	0.74	1757
31	24	5.75	3.57	0.62	1667	5.40	3.35	0.62	1742	5.10	3.16	0.62	1818
31	26	6.05	3.03	0.50	1727	5.70	2.85	0.50	1803	5.35	2.68	0.50	1879
32	18	4.90	4.90	1.00	1485	4.50	4.50	1.00	1576	4.15	4.15	1.00	1636
32	20	5.15	4.64	0.90	1545	4.80	4.32	0.90	1621	4.45	4.01	0.90	1712
32	22	5.45	4.25	0.78	1606	5.10	3.98	0.78	1697	4.75	3.71	0.78	1757
32	24	5.75	3.80	0.66	1667	5.40	3.56	0.66	1742	5.10	3.37	0.66	1818
32	26	6.05	3.27	0.54	1727	5.70	3.08	0.54	1803	5.35	2.89	0.54	1879

**NOTE** Q : Total capacity (kW) SHF : Sensible heat factor DB : Dry-bulb temperature  
 SHC : Sensible heat capacity (kW) INPUT : Total power input (W) WB : Wet-bulb temperature

**PERFORMANCE DATA COOL operation at Rated frequency**

**MUZ-GE60VA**

CAPACITY: 6.0 kW

SHF: 0.79

INPUT: 1760 W

INDOOR DB (°C)	INDOOR WB (°C)	OUTDOOR DB (°C)															
		21				25				27				30			
		Q	SHC	SHF	INPUT	Q	SHC	SHF	INPUT	Q	SHC	SHF	INPUT	Q	SHC	SHF	INPUT
21	18	7.05	4.30	0.61	1408	6.75	4.12	0.61	1478	6.48	3.95	0.61	1549	6.24	3.81	0.61	1619
21	20	7.35	3.60	0.49	1478	7.05	3.45	0.49	1566	6.84	3.35	0.49	1602	6.60	3.23	0.49	1672
22	18	7.05	4.58	0.65	1408	6.75	4.39	0.65	1478	6.48	4.21	0.65	1549	6.24	4.06	0.65	1619
22	20	7.35	3.90	0.53	1478	7.05	3.74	0.53	1566	6.84	3.63	0.53	1602	6.60	3.50	0.53	1672
22	22	7.65	3.14	0.41	1531	7.38	3.03	0.41	1628	7.20	2.95	0.41	1672	6.90	2.83	0.41	1742
23	18	7.05	4.86	0.69	1408	6.75	4.66	0.69	1478	6.48	4.47	0.69	1549	6.24	4.31	0.69	1619
23	20	7.35	4.19	0.57	1478	7.05	4.02	0.57	1566	6.84	3.90	0.57	1602	6.60	3.76	0.57	1672
23	22	7.65	3.44	0.45	1531	7.38	3.32	0.45	1628	7.20	3.24	0.45	1672	6.90	3.11	0.45	1742
24	18	7.05	5.15	0.73	1408	6.75	4.93	0.73	1478	6.48	4.73	0.73	1549	6.24	4.56	0.73	1619
24	20	7.35	4.48	0.61	1478	7.05	4.30	0.61	1566	6.84	4.17	0.61	1602	6.60	4.03	0.61	1672
24	22	7.65	3.75	0.49	1531	7.38	3.62	0.49	1628	7.20	3.53	0.49	1672	6.90	3.38	0.49	1742
24	24	8.04	2.97	0.37	1602	7.74	2.86	0.37	1690	7.56	2.80	0.37	1742	7.32	2.71	0.37	1830
25	18	7.05	5.43	0.77	1408	6.75	5.20	0.77	1478	6.48	4.99	0.77	1549	6.24	4.80	0.77	1619
25	20	7.35	4.78	0.65	1478	7.05	4.58	0.65	1566	6.84	4.45	0.65	1602	6.60	4.29	0.65	1672
25	22	7.65	4.05	0.53	1531	7.38	3.91	0.53	1628	7.20	3.82	0.53	1672	6.90	3.66	0.53	1742
25	24	8.04	3.30	0.41	1602	7.74	3.17	0.41	1690	7.56	3.10	0.41	1742	7.32	3.00	0.41	1830
26	18	7.05	5.71	0.81	1408	6.75	5.47	0.81	1478	6.48	5.25	0.81	1549	6.24	5.05	0.81	1619
26	20	7.35	5.07	0.69	1478	7.05	4.86	0.69	1566	6.84	4.72	0.69	1602	6.60	4.55	0.69	1672
26	22	7.65	4.36	0.57	1531	7.38	4.21	0.57	1628	7.20	4.10	0.57	1672	6.90	3.93	0.57	1742
26	24	8.04	3.62	0.45	1602	7.74	3.48	0.45	1690	7.56	3.40	0.45	1742	7.32	3.29	0.45	1830
26	26	8.28	2.73	0.33	1690	8.04	2.65	0.33	1778	7.92	2.61	0.33	1830	7.68	2.53	0.33	1883
27	18	7.05	5.99	0.85	1408	6.75	5.74	0.85	1478	6.48	5.51	0.85	1549	6.24	5.30	0.85	1619
27	20	7.35	5.37	0.73	1478	7.05	5.15	0.73	1566	6.84	4.99	0.73	1602	6.60	4.82	0.73	1672
27	22	7.65	4.67	0.61	1531	7.38	4.50	0.61	1628	7.20	4.39	0.61	1672	6.90	4.21	0.61	1742
27	24	8.04	3.94	0.49	1602	7.74	3.79	0.49	1690	7.56	3.70	0.49	1742	7.32	3.59	0.49	1830
27	26	8.28	3.06	0.37	1690	8.04	2.97	0.37	1778	7.92	2.93	0.37	1830	7.68	2.84	0.37	1883
28	18	7.05	6.27	0.89	1408	6.75	6.01	0.89	1478	6.48	5.77	0.89	1549	6.24	5.55	0.89	1619
28	20	7.35	5.66	0.77	1478	7.05	5.43	0.77	1566	6.84	5.27	0.77	1602	6.60	5.08	0.77	1672
28	22	7.65	4.97	0.65	1531	7.38	4.80	0.65	1628	7.20	4.68	0.65	1672	6.90	4.49	0.65	1742
28	24	8.04	4.26	0.53	1602	7.74	4.10	0.53	1690	7.56	4.01	0.53	1742	7.32	3.88	0.53	1830
28	26	8.28	3.39	0.41	1690	8.04	3.30	0.41	1778	7.92	3.25	0.41	1830	7.68	3.15	0.41	1883
29	18	7.05	6.56	0.93	1408	6.75	6.28	0.93	1478	6.48	6.03	0.93	1549	6.24	5.80	0.93	1619
29	20	7.35	5.95	0.81	1478	7.05	5.71	0.81	1566	6.84	5.54	0.81	1602	6.60	5.35	0.81	1672
29	22	7.65	5.28	0.69	1531	7.38	5.09	0.69	1628	7.20	4.97	0.69	1672	6.90	4.76	0.69	1742
29	24	8.04	4.58	0.57	1602	7.74	4.41	0.57	1690	7.56	4.31	0.57	1742	7.32	4.17	0.57	1830
29	26	8.28	3.73	0.45	1690	8.04	3.62	0.45	1778	7.92	3.56	0.45	1830	7.68	3.46	0.45	1883
30	18	7.05	6.84	0.97	1408	6.75	6.55	0.97	1478	6.48	6.29	0.97	1549	6.24	6.05	0.97	1619
30	20	7.35	6.25	0.85	1478	7.05	5.99	0.85	1566	6.84	5.81	0.85	1602	6.60	5.61	0.85	1672
30	22	7.65	5.58	0.73	1531	7.38	5.39	0.73	1628	7.20	5.26	0.73	1672	6.90	5.04	0.73	1742
30	24	8.04	4.90	0.61	1602	7.74	4.72	0.61	1690	7.56	4.61	0.61	1742	7.32	4.47	0.61	1830
30	26	8.28	4.06	0.49	1690	8.04	3.94	0.49	1778	7.92	3.88	0.49	1830	7.68	3.76	0.49	1883
31	18	7.05	7.05	1.00	1408	6.75	6.75	1.00	1478	6.48	6.48	1.00	1549	6.24	6.24	1.00	1619
31	20	7.35	6.54	0.89	1478	7.05	6.27	0.89	1566	6.84	6.09	0.89	1602	6.60	5.87	0.89	1672
31	22	7.65	5.89	0.77	1531	7.38	5.68	0.77	1628	7.20	5.54	0.77	1672	6.90	5.31	0.77	1742
31	24	8.04	5.23	0.65	1602	7.74	5.03	0.65	1690	7.56	4.91	0.65	1742	7.32	4.76	0.65	1830
31	26	8.28	4.39	0.53	1690	8.04	4.26	0.53	1778	7.92	4.20	0.53	1830	7.68	4.07	0.53	1883
32	18	7.05	7.05	1.00	1408	6.75	6.75	1.00	1478	6.48	6.48	1.00	1549	6.24	6.24	1.00	1619
32	20	7.35	6.84	0.93	1478	7.05	6.56	0.93	1566	6.84	6.36	0.93	1602	6.60	6.14	0.93	1672
32	22	7.65	6.20	0.81	1531	7.38	5.98	0.81	1628	7.20	5.83	0.81	1672	6.90	5.59	0.81	1742
32	24	8.04	5.55	0.69	1602	7.74	5.34	0.69	1690	7.56	5.22	0.69	1742	7.32	5.05	0.69	1830
32	26	8.28	4.72	0.57	1690	8.04	4.58	0.57	1778	7.92	4.51	0.57	1830	7.68	4.38	0.57	1883

**NOTE** Q : Total capacity (kW) SHF : Sensible heat factor DB : Dry-bulb temperature  
 SHC : Sensible heat capacity (kW) INPUT : Total power input (W) WB : Wet-bulb temperature

**PERFORMANCE DATA COOL operation at Rated frequency**

**MUZ-GE60VA**

CAPACITY: 6.0 kW

SHF: 0.79

INPUT: 1760 W

INDOOR DB (°C)	INDOOR WB (°C)	OUTDOOR DB (°C)											
		35				40				46			
		Q	SHC	SHF	INPUT	Q	SHC	SHF	INPUT	Q	SHC	SHF	INPUT
21	18	5.88	3.59	0.61	1725	5.40	3.29	0.61	1830	4.98	3.04	0.61	1901
21	20	6.18	3.03	0.49	1795	5.76	2.82	0.49	1883	5.34	2.62	0.49	1989
22	18	5.88	3.82	0.65	1725	5.40	3.51	0.65	1830	4.98	3.24	0.65	1901
22	20	6.18	3.28	0.53	1795	5.76	3.05	0.53	1883	5.34	2.83	0.53	1989
22	22	6.54	2.68	0.41	1866	6.12	2.51	0.41	1971	5.70	2.34	0.41	2042
23	18	5.88	4.06	0.69	1725	5.40	3.73	0.69	1830	4.98	3.44	0.69	1901
23	20	6.18	3.52	0.57	1795	5.76	3.28	0.57	1883	5.34	3.04	0.57	1989
23	22	6.54	2.94	0.45	1866	6.12	2.75	0.45	1971	5.70	2.57	0.45	2042
24	18	5.88	4.29	0.73	1725	5.40	3.94	0.73	1830	4.98	3.64	0.73	1901
24	20	6.18	3.77	0.61	1795	5.76	3.51	0.61	1883	5.34	3.26	0.61	1989
24	22	6.54	3.20	0.49	1866	6.12	3.00	0.49	1971	5.70	2.79	0.49	2042
24	24	6.90	2.55	0.37	1936	6.48	2.40	0.37	2024	6.12	2.26	0.37	2112
25	18	5.88	4.53	0.77	1725	5.40	4.16	0.77	1830	4.98	3.83	0.77	1901
25	20	6.18	4.02	0.65	1795	5.76	3.74	0.65	1883	5.34	3.47	0.65	1989
25	22	6.54	3.47	0.53	1866	6.12	3.24	0.53	1971	5.70	3.02	0.53	2042
25	24	6.90	2.83	0.41	1936	6.48	2.66	0.41	2024	6.12	2.51	0.41	2112
26	18	5.88	4.76	0.81	1725	5.40	4.37	0.81	1830	4.98	4.03	0.81	1901
26	20	6.18	4.26	0.69	1795	5.76	3.97	0.69	1883	5.34	3.68	0.69	1989
26	22	6.54	3.73	0.57	1866	6.12	3.49	0.57	1971	5.70	3.25	0.57	2042
26	24	6.90	3.11	0.45	1936	6.48	2.92	0.45	2024	6.12	2.75	0.45	2112
26	26	7.26	2.40	0.33	2006	6.84	2.26	0.33	2094	6.42	2.12	0.33	2182
27	18	5.88	5.00	0.85	1725	5.40	4.59	0.85	1830	4.98	4.23	0.85	1901
27	20	6.18	4.51	0.73	1795	5.76	4.20	0.73	1883	5.34	3.90	0.73	1989
27	22	6.54	3.99	0.61	1866	6.12	3.73	0.61	1971	5.70	3.48	0.61	2042
27	24	6.90	3.38	0.49	1936	6.48	3.18	0.49	2024	6.12	3.00	0.49	2112
27	26	7.26	2.69	0.37	2006	6.84	2.53	0.37	2094	6.42	2.38	0.37	2182
28	18	5.88	5.23	0.89	1725	5.40	4.81	0.89	1830	4.98	4.43	0.89	1901
28	20	6.18	4.76	0.77	1795	5.76	4.44	0.77	1883	5.34	4.11	0.77	1989
28	22	6.54	4.25	0.65	1866	6.12	3.98	0.65	1971	5.70	3.71	0.65	2042
28	24	6.90	3.66	0.53	1936	6.48	3.43	0.53	2024	6.12	3.24	0.53	2112
28	26	7.26	2.98	0.41	2006	6.84	2.80	0.41	2094	6.42	2.63	0.41	2182
29	18	5.88	5.47	0.93	1725	5.40	5.02	0.93	1830	4.98	4.63	0.93	1901
29	20	6.18	5.01	0.81	1795	5.76	4.67	0.81	1883	5.34	4.33	0.81	1989
29	22	6.54	4.51	0.69	1866	6.12	4.22	0.69	1971	5.70	3.93	0.69	2042
29	24	6.90	3.93	0.57	1936	6.48	3.69	0.57	2024	6.12	3.49	0.57	2112
29	26	7.26	3.27	0.45	2006	6.84	3.08	0.45	2094	6.42	2.89	0.45	2182
30	18	5.88	5.70	0.97	1725	5.40	5.24	0.97	1830	4.98	4.83	0.97	1901
30	20	6.18	5.25	0.85	1795	5.76	4.90	0.85	1883	5.34	4.54	0.85	1989
30	22	6.54	4.77	0.73	1866	6.12	4.47	0.73	1971	5.70	4.16	0.73	2042
30	24	6.90	4.21	0.61	1936	6.48	3.95	0.61	2024	6.12	3.73	0.61	2112
30	26	7.26	3.56	0.49	2006	6.84	3.35	0.49	2094	6.42	3.15	0.49	2182
31	18	5.88	5.88	1.00	1725	5.40	5.40	1.00	1830	4.98	4.98	1.00	1901
31	20	6.18	5.50	0.89	1795	5.76	5.13	0.89	1883	5.34	4.75	0.89	1989
31	22	6.54	5.04	0.77	1866	6.12	4.71	0.77	1971	5.70	4.39	0.77	2042
31	24	6.90	4.49	0.65	1936	6.48	4.21	0.65	2024	6.12	3.98	0.65	2112
31	26	7.26	3.85	0.53	2006	6.84	3.63	0.53	2094	6.42	3.40	0.53	2182
32	18	5.88	5.88	1.00	1725	5.40	5.40	1.00	1830	4.98	4.98	1.00	1901
32	20	6.18	5.75	0.93	1795	5.76	5.36	0.93	1883	5.34	4.97	0.93	1989
32	22	6.54	5.30	0.81	1866	6.12	4.96	0.81	1971	5.70	4.62	0.81	2042
32	24	6.90	4.76	0.69	1936	6.48	4.47	0.69	2024	6.12	4.22	0.69	2112
32	26	7.26	4.14	0.57	2006	6.84	3.90	0.57	2094	6.42	3.66	0.57	2182

**NOTE** Q : Total capacity (kW) SHF : Sensible heat factor DB : Dry-bulb temperature  
 SHC : Sensible heat capacity (kW) INPUT : Total power input (W) WB : Wet-bulb temperature

**PERFORMANCE DATA COOL operation at Rated frequency**

**MUZ-GE71VA**

CAPACITY: 7.1 kW

SHF: 0.78

INPUT: 2130 W

INDOOR DB (°C)	INDOOR WB (°C)	OUTDOOR DB (°C)															
		21				25				27				30			
		Q	SHC	SHF	INPUT	Q	SHC	SHF	INPUT	Q	SHC	SHF	INPUT	Q	SHC	SHF	INPUT
21	18	8.34	5.01	0.60	1704	7.99	4.79	0.60	1789	7.67	4.60	0.60	1874	7.38	4.43	0.60	1960
21	20	8.70	4.17	0.48	1789	8.34	4.00	0.48	1896	8.09	3.89	0.48	1938	7.81	3.75	0.48	2024
22	18	8.34	5.34	0.64	1704	7.99	5.11	0.64	1789	7.67	4.91	0.64	1874	7.38	4.73	0.64	1960
22	20	8.70	4.52	0.52	1789	8.34	4.34	0.52	1896	8.09	4.21	0.52	1938	7.81	4.06	0.52	2024
22	22	9.05	3.62	0.40	1853	8.73	3.49	0.40	1970	8.52	3.41	0.40	2024	8.17	3.27	0.40	2109
23	18	8.34	5.67	0.68	1704	7.99	5.43	0.68	1789	7.67	5.21	0.68	1874	7.38	5.02	0.68	1960
23	20	8.70	4.87	0.56	1789	8.34	4.67	0.56	1896	8.09	4.53	0.56	1938	7.81	4.37	0.56	2024
23	22	9.05	3.98	0.44	1853	8.73	3.84	0.44	1970	8.52	3.75	0.44	2024	8.17	3.59	0.44	2109
24	18	8.34	6.01	0.72	1704	7.99	5.75	0.72	1789	7.67	5.52	0.72	1874	7.38	5.32	0.72	1960
24	20	8.70	5.22	0.60	1789	8.34	5.01	0.60	1896	8.09	4.86	0.60	1938	7.81	4.69	0.60	2024
24	22	9.05	4.35	0.48	1853	8.73	4.19	0.48	1970	8.52	4.09	0.48	2024	8.17	3.92	0.48	2109
24	24	9.51	3.43	0.36	1938	9.16	3.30	0.36	2045	8.95	3.22	0.36	2109	8.66	3.12	0.36	2215
25	18	8.34	6.34	0.76	1704	7.99	6.07	0.76	1789	7.67	5.83	0.76	1874	7.38	5.61	0.76	1960
25	20	8.70	5.57	0.64	1789	8.34	5.34	0.64	1896	8.09	5.18	0.64	1938	7.81	5.00	0.64	2024
25	22	9.05	4.71	0.52	1853	8.73	4.54	0.52	1970	8.52	4.43	0.52	2024	8.17	4.25	0.52	2109
25	24	9.51	3.81	0.40	1938	9.16	3.66	0.40	2045	8.95	3.58	0.40	2109	8.66	3.46	0.40	2215
26	18	8.34	6.67	0.80	1704	7.99	6.39	0.80	1789	7.67	6.13	0.80	1874	7.38	5.91	0.80	1960
26	20	8.70	5.91	0.68	1789	8.34	5.67	0.68	1896	8.09	5.50	0.68	1938	7.81	5.31	0.68	2024
26	22	9.05	5.07	0.56	1853	8.73	4.89	0.56	1970	8.52	4.77	0.56	2024	8.17	4.57	0.56	2109
26	24	9.51	4.19	0.44	1938	9.16	4.03	0.44	2045	8.95	3.94	0.44	2109	8.66	3.81	0.44	2215
26	26	9.80	3.14	0.32	2045	9.51	3.04	0.32	2151	9.37	3.00	0.32	2215	9.09	2.91	0.32	2279
27	18	8.34	7.01	0.84	1704	7.99	6.71	0.84	1789	7.67	6.44	0.84	1874	7.38	6.20	0.84	1960
27	20	8.70	6.26	0.72	1789	8.34	6.01	0.72	1896	8.09	5.83	0.72	1938	7.81	5.62	0.72	2024
27	22	9.05	5.43	0.60	1853	8.73	5.24	0.60	1970	8.52	5.11	0.60	2024	8.17	4.90	0.60	2109
27	24	9.51	4.57	0.48	1938	9.16	4.40	0.48	2045	8.95	4.29	0.48	2109	8.66	4.16	0.48	2215
27	26	9.80	3.53	0.36	2045	9.51	3.43	0.36	2151	9.37	3.37	0.36	2215	9.09	3.27	0.36	2279
28	18	8.34	7.34	0.88	1704	7.99	7.03	0.88	1789	7.67	6.75	0.88	1874	7.38	6.50	0.88	1960
28	20	8.70	6.61	0.76	1789	8.34	6.34	0.76	1896	8.09	6.15	0.76	1938	7.81	5.94	0.76	2024
28	22	9.05	5.79	0.64	1853	8.73	5.59	0.64	1970	8.52	5.45	0.64	2024	8.17	5.23	0.64	2109
28	24	9.51	4.95	0.52	1938	9.16	4.76	0.52	2045	8.95	4.65	0.52	2109	8.66	4.50	0.52	2215
28	26	9.80	3.92	0.40	2045	9.51	3.81	0.40	2151	9.37	3.75	0.40	2215	9.09	3.64	0.40	2279
29	18	8.34	7.68	0.92	1704	7.99	7.35	0.92	1789	7.67	7.05	0.92	1874	7.38	6.79	0.92	1960
29	20	8.70	6.96	0.80	1789	8.34	6.67	0.80	1896	8.09	6.48	0.80	1938	7.81	6.25	0.80	2024
29	22	9.05	6.16	0.68	1853	8.73	5.94	0.68	1970	8.52	5.79	0.68	2024	8.17	5.55	0.68	2109
29	24	9.51	5.33	0.56	1938	9.16	5.13	0.56	2045	8.95	5.01	0.56	2109	8.66	4.85	0.56	2215
29	26	9.80	4.31	0.44	2045	9.51	4.19	0.44	2151	9.37	4.12	0.44	2215	9.09	4.00	0.44	2279
30	18	8.34	8.01	0.96	1704	7.99	7.67	0.96	1789	7.67	7.36	0.96	1874	7.38	7.09	0.96	1960
30	20	8.70	7.31	0.84	1789	8.34	7.01	0.84	1896	8.09	6.80	0.84	1938	7.81	6.56	0.84	2024
30	22	9.05	6.52	0.72	1853	8.73	6.29	0.72	1970	8.52	6.13	0.72	2024	8.17	5.88	0.72	2109
30	24	9.51	5.71	0.60	1938	9.16	5.50	0.60	2045	8.95	5.37	0.60	2109	8.66	5.20	0.60	2215
30	26	9.80	4.70	0.48	2045	9.51	4.57	0.48	2151	9.37	4.50	0.48	2215	9.09	4.36	0.48	2279
31	18	8.34	8.34	1.00	1704	7.99	7.99	1.00	1789	7.67	7.67	1.00	1874	7.38	7.38	1.00	1960
31	20	8.70	7.65	0.88	1789	8.34	7.34	0.88	1896	8.09	7.12	0.88	1938	7.81	6.87	0.88	2024
31	22	9.05	6.88	0.76	1853	8.73	6.64	0.76	1970	8.52	6.48	0.76	2024	8.17	6.21	0.76	2109
31	24	9.51	6.09	0.64	1938	9.16	5.86	0.64	2045	8.95	5.73	0.64	2109	8.66	5.54	0.64	2215
31	26	9.80	5.09	0.52	2045	9.51	4.95	0.52	2151	9.37	4.87	0.52	2215	9.09	4.73	0.52	2279
32	18	8.34	8.34	1.00	1704	7.99	7.99	1.00	1789	7.67	7.67	1.00	1874	7.38	7.38	1.00	1960
32	20	8.70	8.00	0.92	1789	8.34	7.68	0.92	1896	8.09	7.45	0.92	1938	7.81	7.19	0.92	2024
32	22	9.05	7.24	0.80	1853	8.73	6.99	0.80	1970	8.52	6.82	0.80	2024	8.17	6.53	0.80	2109
32	24	9.51	6.47	0.68	1938	9.16	6.23	0.68	2045	8.95	6.08	0.68	2109	8.66	5.89	0.68	2215
32	26	9.80	5.49	0.56	2045	9.51	5.33	0.56	2151	9.37	5.25	0.56	2215	9.09	5.09	0.56	2279

**NOTE** Q : Total capacity (kW) SHF : Sensible heat factor DB : Dry-bulb temperature  
 SHC : Sensible heat capacity (kW) INPUT : Total power input (W) WB : Wet-bulb temperature

**PERFORMANCE DATA COOL operation at Rated frequency**

**MUZ-GE71VA**

CAPACITY: 7.1 kW

SHF: 0.78

INPUT: 2130 W

INDOOR DB (°C)	INDOOR WB (°C)	OUTDOOR DB (°C)											
		35				40				46			
		Q	SHC	SHF	INPUT	Q	SHC	SHF	INPUT	Q	SHC	SHF	INPUT
21	18	6.96	4.17	0.60	2087	6.39	3.83	0.60	2215	5.89	3.54	0.60	2300
21	20	7.31	3.51	0.48	2173	6.82	3.27	0.48	2279	6.32	3.03	0.48	2407
22	18	6.96	4.45	0.64	2087	6.39	4.09	0.64	2215	5.89	3.77	0.64	2300
22	20	7.31	3.80	0.52	2173	6.82	3.54	0.52	2279	6.32	3.29	0.52	2407
22	22	7.74	3.10	0.40	2258	7.24	2.90	0.40	2386	6.75	2.70	0.40	2471
23	18	6.96	4.73	0.68	2087	6.39	4.35	0.68	2215	5.89	4.01	0.68	2300
23	20	7.31	4.10	0.56	2173	6.82	3.82	0.56	2279	6.32	3.54	0.56	2407
23	22	7.74	3.41	0.44	2258	7.24	3.19	0.44	2386	6.75	2.97	0.44	2471
24	18	6.96	5.01	0.72	2087	6.39	4.60	0.72	2215	5.89	4.24	0.72	2300
24	20	7.31	4.39	0.60	2173	6.82	4.09	0.60	2279	6.32	3.79	0.60	2407
24	22	7.74	3.71	0.48	2258	7.24	3.48	0.48	2386	6.75	3.24	0.48	2471
24	24	8.17	2.94	0.36	2343	7.67	2.76	0.36	2450	7.24	2.61	0.36	2556
25	18	6.96	5.29	0.76	2087	6.39	4.86	0.76	2215	5.89	4.48	0.76	2300
25	20	7.31	4.68	0.64	2173	6.82	4.36	0.64	2279	6.32	4.04	0.64	2407
25	22	7.74	4.02	0.52	2258	7.24	3.77	0.52	2386	6.75	3.51	0.52	2471
25	24	8.17	3.27	0.40	2343	7.67	3.07	0.40	2450	7.24	2.90	0.40	2556
26	18	6.96	5.57	0.80	2087	6.39	5.11	0.80	2215	5.89	4.71	0.80	2300
26	20	7.31	4.97	0.68	2173	6.82	4.63	0.68	2279	6.32	4.30	0.68	2407
26	22	7.74	4.33	0.56	2258	7.24	4.06	0.56	2386	6.75	3.78	0.56	2471
26	24	8.17	3.59	0.44	2343	7.67	3.37	0.44	2450	7.24	3.19	0.44	2556
26	26	8.59	2.75	0.32	2428	8.09	2.59	0.32	2535	7.60	2.43	0.32	2641
27	18	6.96	5.84	0.84	2087	6.39	5.37	0.84	2215	5.89	4.95	0.84	2300
27	20	7.31	5.27	0.72	2173	6.82	4.91	0.72	2279	6.32	4.55	0.72	2407
27	22	7.74	4.64	0.60	2258	7.24	4.35	0.60	2386	6.75	4.05	0.60	2471
27	24	8.17	3.92	0.48	2343	7.67	3.68	0.48	2450	7.24	3.48	0.48	2556
27	26	8.59	3.09	0.36	2428	8.09	2.91	0.36	2535	7.60	2.73	0.36	2641
28	18	6.96	6.12	0.88	2087	6.39	5.62	0.88	2215	5.89	5.19	0.88	2300
28	20	7.31	5.56	0.76	2173	6.82	5.18	0.76	2279	6.32	4.80	0.76	2407
28	22	7.74	4.95	0.64	2258	7.24	4.63	0.64	2386	6.75	4.32	0.64	2471
28	24	8.17	4.25	0.52	2343	7.67	3.99	0.52	2450	7.24	3.77	0.52	2556
28	26	8.59	3.44	0.40	2428	8.09	3.24	0.40	2535	7.60	3.04	0.40	2641
29	18	6.96	6.40	0.92	2087	6.39	5.88	0.92	2215	5.89	5.42	0.92	2300
29	20	7.31	5.85	0.80	2173	6.82	5.45	0.80	2279	6.32	5.06	0.80	2407
29	22	7.74	5.26	0.68	2258	7.24	4.92	0.68	2386	6.75	4.59	0.68	2471
29	24	8.17	4.57	0.56	2343	7.67	4.29	0.56	2450	7.24	4.06	0.56	2556
29	26	8.59	3.78	0.44	2428	8.09	3.56	0.44	2535	7.60	3.34	0.44	2641
30	18	6.96	6.68	0.96	2087	6.39	6.13	0.96	2215	5.89	5.66	0.96	2300
30	20	7.31	6.14	0.84	2173	6.82	5.73	0.84	2279	6.32	5.31	0.84	2407
30	22	7.74	5.57	0.72	2258	7.24	5.21	0.72	2386	6.75	4.86	0.72	2471
30	24	8.17	4.90	0.60	2343	7.67	4.60	0.60	2450	7.24	4.35	0.60	2556
30	26	8.59	4.12	0.48	2428	8.09	3.89	0.48	2535	7.60	3.65	0.48	2641
31	18	6.96	6.96	1.00	2087	6.39	6.39	1.00	2215	5.89	5.89	1.00	2300
31	20	7.31	6.44	0.88	2173	6.82	6.00	0.88	2279	6.32	5.56	0.88	2407
31	22	7.74	5.88	0.76	2258	7.24	5.50	0.76	2386	6.75	5.13	0.76	2471
31	24	8.17	5.23	0.64	2343	7.67	4.91	0.64	2450	7.24	4.63	0.64	2556
31	26	8.59	4.47	0.52	2428	8.09	4.21	0.52	2535	7.60	3.95	0.52	2641
32	18	6.96	6.96	1.00	2087	6.39	6.39	1.00	2215	5.89	5.89	1.00	2300
32	20	7.31	6.73	0.92	2173	6.82	6.27	0.92	2279	6.32	5.81	0.92	2407
32	22	7.74	6.19	0.80	2258	7.24	5.79	0.80	2386	6.75	5.40	0.80	2471
32	24	8.17	5.55	0.68	2343	7.67	5.21	0.68	2450	7.24	4.92	0.68	2556
32	26	8.59	4.81	0.56	2428	8.09	4.53	0.56	2535	7.60	4.25	0.56	2641

**NOTE** Q : Total capacity (kW) SHF : Sensible heat factor DB : Dry-bulb temperature  
 SHC : Sensible heat capacity (kW) INPUT : Total power input (W) WB : Wet-bulb temperature

**PERFORMANCE DATA HEAT operation at Rated frequency**  
**MUZ-GE25VA MUZ-GE25VAH**

CAPACITY: 3.2 kW INPUT: 700 W

INDOOR DB (°C)	OUTDOOR WB (°C)													
	-10		-5		0		5		10		15		20	
	Q	INPUT	Q	INPUT	Q	INPUT	Q	INPUT	Q	INPUT	Q	INPUT	Q	INPUT
15	2.02	455	2.43	546	2.85	616	3.26	665	3.68	707	4.06	728	4.48	742
21	1.92	490	2.30	581	2.72	644	3.10	693	3.52	728	3.90	749	4.30	777
26	1.73	525	2.14	616	2.53	679	2.94	728	3.36	763	3.74	784	4.16	805

**MUZ-GE35VA MUZ-GE35VAH**

CAPACITY: 4.0 kW INPUT: 955 W

INDOOR DB (°C)	OUTDOOR WB (°C)													
	-10		-5		0		5		10		15		20	
	Q	INPUT	Q	INPUT	Q	INPUT	Q	INPUT	Q	INPUT	Q	INPUT	Q	INPUT
15	2.52	621	3.04	745	3.56	840	4.08	907	4.60	965	5.08	993	5.60	1012
21	2.40	669	2.88	793	3.40	879	3.88	945	4.40	993	4.88	1022	5.38	1060
26	2.16	716	2.68	840	3.16	926	3.68	993	4.20	1041	4.68	1070	5.20	1098

**MUZ-GE42VA MUZ-GE42VAH**

CAPACITY: 5.4 kW INPUT: 1460 W

INDOOR DB (°C)	OUTDOOR WB (°C)													
	-10		-5		0		5		10		15		20	
	Q	INPUT	Q	INPUT	Q	INPUT	Q	INPUT	Q	INPUT	Q	INPUT	Q	INPUT
15	3.40	949	4.10	1139	4.81	1285	5.51	1387	6.21	1475	6.86	1518	7.56	1548
21	3.24	1022	3.89	1212	4.59	1343	5.24	1445	5.94	1518	6.59	1562	7.26	1621
26	2.92	1095	3.62	1285	4.27	1416	4.97	1518	5.67	1591	6.32	1635	7.02	1679

**MUZ-GE50VAH MUZ-GE50VAH**

CAPACITY: 5.8 kW INPUT: 1565 W

INDOOR DB (°C)	OUTDOOR WB (°C)													
	-10		-5		0		5		10		15		20	
	Q	INPUT	Q	INPUT	Q	INPUT	Q	INPUT	Q	INPUT	Q	INPUT	Q	INPUT
15	3.65	1017	4.41	1221	5.16	1377	5.92	1487	6.67	1581	7.37	1628	8.12	1659
21	3.48	1096	4.18	1299	4.93	1440	5.63	1549	6.38	1628	7.08	1675	7.80	1737
26	3.13	1174	3.89	1377	4.58	1518	5.34	1628	6.09	1706	6.79	1753	7.54	1800

**MUZ-GE60VA**

CAPACITY: 6.8 kW INPUT: 1770 W

INDOOR DB (°C)	OUTDOOR WB (°C)													
	-10		-5		0		5		10		15		20	
	Q	INPUT	Q	INPUT	Q	INPUT	Q	INPUT	Q	INPUT	Q	INPUT	Q	INPUT
15	4.28	1151	5.17	1381	6.05	1558	6.94	1682	7.82	1788	8.64	1841	9.52	1876
21	4.08	1239	4.90	1469	5.78	1628	6.60	1752	7.48	1841	8.30	1894	9.15	1965
26	3.67	1328	4.56	1558	5.37	1717	6.26	1841	7.14	1929	7.96	1982	8.84	2036

**MUZ-GE71VA**

CAPACITY: 8.1 kW INPUT: 2110 W

INDOOR DB (°C)	OUTDOOR WB (°C)													
	-10		-5		0		5		10		15		20	
	Q	INPUT	Q	INPUT	Q	INPUT	Q	INPUT	Q	INPUT	Q	INPUT	Q	INPUT
15	5.10	1372	6.16	1646	7.21	1857	8.26	2005	9.32	2131	10.29	2194	11.34	2237
21	4.86	1477	5.83	1751	6.89	1941	7.86	2089	8.91	2194	9.88	2258	10.89	2342
26	4.37	1583	5.43	1857	6.40	2047	7.45	2194	8.51	2300	9.48	2363	10.53	2427

**NOTE:** Q: Total capacity (kW) INPUT : Total power input (W) DB: Dry-bulb temperature WB: Wet-bulb temperature

**MUZ-GE25VA MUZ-GE25VAH MUZ-GE35VA MUZ-GE35VAH MUZ-GE42VA MUZ-GE42VAH  
MUZ-GE50VA MUZ-GE50VAH MUZ-GE60VA MUZ-GE71VA**

**9-1. OUTDOOR FAN MOTOR CONTROL**

The fan motor turns ON/OFF, interlocking with the compressor.

[ON] The fan motor turns ON 5 seconds before the compressor starts up.

[OFF] The fan motor turns OFF 15 seconds after the compressor has stopped running.

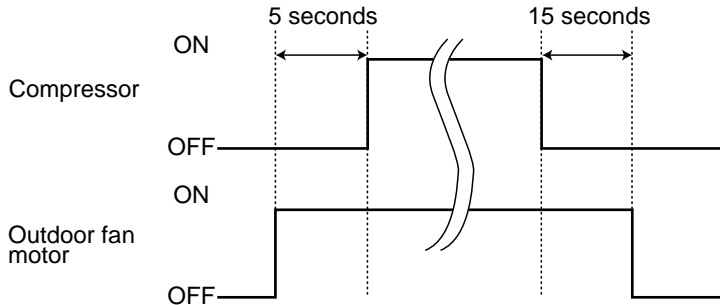

**9-2. R.V. COIL CONTROL**

Heating ..... ON

Cooling ..... OFF

Dry ..... OFF

**NOTE:** The 4-way valve reverses for 5 seconds right before start-up of the compressor.

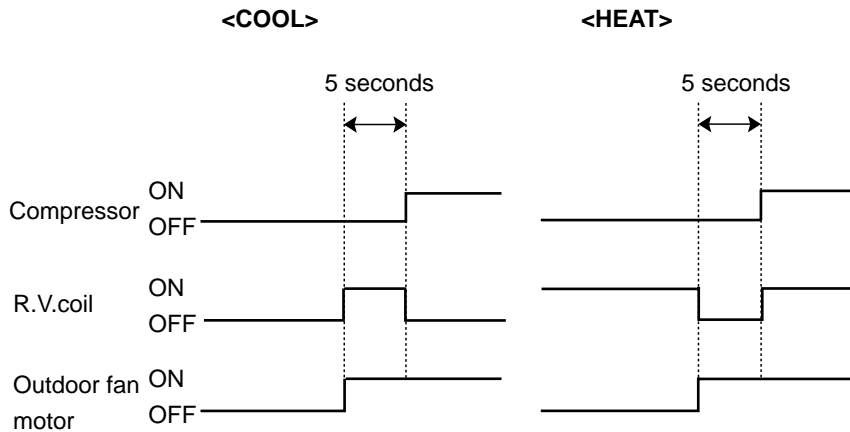

**9-3. RELATION BETWEEN MAIN SENSOR AND ACTUATOR**

Sensor	Purpose	Actuator					
		Compressor	LEV	Outdoor fan motor	R.V.coil	Indoor fan motor	Defrost heater
Discharge temperature thermistor	Protection	○	○				
Indoor coil temperature thermistor	Cooling: Coil frost prevention	○					
	Heating: High pressure protection	○	○				
Defrost thermistor	Heating: Defrosting	○	○	○	○	○	
Fin temperature thermistor	Protection	○		○			
Ambient temperature thermistor	Cooling: Low ambient temperature operation	○	○	○			
	Heating: Defrosting (Heater)						○
Outdoor heat exchanger temperature thermistor	Cooling: Low ambient temperature operation	○	○	○			
	Cooling: High pressure protection	○	○	○			



# 10

# SERVICE FUNCTIONS

MUZ-GE25VA MUZ-GE25VAH MUZ-GE35VA MUZ-GE35VAH MUZ-GE42VA MUZ-GE42VAH  
 MUZ-GE50VA MUZ-GE50VAH MUZ-GE60VA MUZ-GE71VA

## 10-1. CHANGE IN DEFROST SETTING

### Changing defrost finish temperature

<JS> To change the defrost finish temperature, cut/solder the JS wire of the outdoor inverter P.C. board. (Refer to 11-6-1.)

Jumper wire		Defrost finish temperature (°C)		
		MUZ-GE25/35/42	MUZ-GE50	MUZ-GE60/71
JS	Soldered (Initial setting)	5	9	10
	None (Cut)	10	18	18

## 10-2. PRE-HEAT CONTROL SETTING

### PRE-HEAT CONTROL

When moisture gets into the refrigerant cycle, it may interfere the start-up of the compressor at low outside temperature. The pre-heat control prevents this interference. The pre-heat control turns ON when outside temperature is 20°C or below. When pre-heat control is turned ON, compressor is energized. (About 50 W)

<JK> To activate the pre-heat control, cut the JK wire of the inverter P.C. board. (Refer to 11-6.1)

**NOTE:** When the inverter P.C. board is replaced, check the Jumper wires, and cut/solder them if necessary.

# 11

# TROUBLESHOOTING

MUZ-GE25VA MUZ-GE25VAH MUZ-GE35VA MUZ-GE35VAH MUZ-GE42VA MUZ-GE42VAH  
 MUZ-GE50VA MUZ-GE50VAH MUZ-GE60VA MUZ-GE71VA

## 11-1. CAUTIONS ON TROUBLESHOOTING

### 1. Before troubleshooting, check the following

- 1) Check the power supply voltage.
- 2) Check the indoor/outdoor connecting wire for miswiring.

### 2. Take care of the following during servicing

- 1) Before servicing the air conditioner, be sure to turn OFF the main unit first with the remote controller, and then after confirming the horizontal vane is closed, turn OFF the breaker and/or disconnect the power plug.
- 2) Be sure to turn OFF the power supply before removing the front panel, the cabinet, the top panel, and the electronic control P.C. board.
- 3) When removing the electrical parts, be careful of the residual voltage of smoothing capacitor.
- 4) When removing the electronic control P.C. board, hold the edge of the board with care NOT to apply stress on the components.
- 5) When connecting or disconnecting the connectors, hold the housing of the connector. DO NOT pull the lead wires.

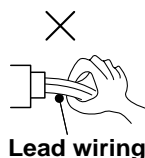

### 3. Troubleshooting procedure

- 1) First, check if the OPERATION INDICATOR lamp on the indoor unit is flashing on and off to indicate an abnormality. To make sure, check how many times the abnormality indication is flashing on and off before starting service work.
- 2) Before servicing, check that the connector and terminal are connected properly.
- 3) When the electronic control P.C. board seems to be defective, check the copper foil pattern for disconnection and the components for bursting and discoloration.
- 4) Refer to 11-2 and 11-3.

## 11-2. FAILURE MODE RECALL FUNCTION

Outline of the function

This air conditioner can memorize the abnormal condition which has occurred once.

Even though LED indication listed on the troubleshooting check table (11-3.) disappears, the memorized failure details can be recalled.

### 1. Flow chart of failure mode recall function for the indoor/outdoor unit

MSZ-GE25VA MSZ-GE42VA  
MSZ-GE35VA MSZ-GE50VA

MSZ-GE60VA  
MSZ-GE71VA

Operational procedure

The cause of abnormality cannot be found because the abnormality does not recur.

Setting up the failure mode recall function

Turn ON the power supply.  
<Preparation of the remote controller>  
① While pressing both OPERATION SELECT button and TOO COOL button (MSZ-GE25/35/42/50VA)/TEMP button (MSZ-GE60/71VA) on the remote controller at the same time, press RESET button.  
② First, release RESET button.  
And release the other two buttons after all LCD in operation display section of the remote controller is displayed after 3 seconds.

Press OPERATE/STOP (ON/OFF) button of the remote controller (the set temperature is displayed) with the remote controller headed towards the indoor unit. ※1

※1. Regardless of normal or abnormal condition, a short beep is emitted once the signal is received.

Does the upper lamp of OPERATION INDICATOR lamp on the indoor unit blink at the interval of 0.5 seconds?  
Blinks: Either indoor or outdoor unit is abnormal. Beep is emitted at the same timing as the blinking of the upper lamp of OPERATION INDICATOR lamp. ※2

No (OFF)

Indoor unit is normal.  
But the outdoor unit might be abnormal because there are some abnormalities that can not be recalled with this way.  
Confirm if outdoor unit is abnormal according to the detailed outdoor unit failure mode recall function. (Refer to 11-2.2)

Judgment of indoor/outdoor abnormality

Yes (Blinks)

Before blinking, does the upper lamp of OPERATION INDICATOR lamp stay ON for 3 seconds?  
Stays ON for 3 seconds (without beep):  
The outdoor unit is abnormal.

Yes

The indoor unit is abnormal.  
Check the blinking pattern, and confirm the abnormal point with the indoor unit failure mode table. (Refer to indoor unit service manual.)  
Make sure to check at least two consecutive blinking cycles. ※2

The outdoor unit is abnormal.  
Check the blinking pattern, and confirm the abnormal point with the outdoor unit failure mode table. (Refer to 11-2.3)  
Make sure to check at least two consecutive blinking cycles. ※3

Releasing the failure mode recall function

Release the failure mode recall function by the following procedures.  
Turn OFF the power supply and turn it ON again.  
Press RESET button of the remote controller.

Repair the defective parts.

Deleting the memorized abnormal condition

① After repairing the unit, recall the failure mode again according to "Setting up the failure mode recall function" mentioned above.  
② Press OPERATE/STOP (ON/OFF) button of the remote controller (the set temperature is displayed) with the remote controller headed towards the indoor unit.  
③ Press EMERGENCY OPERATION switch so that the memorized abnormal condition is deleted.  
④ Release the failure mode recall function according to "Releasing the failure mode recall function" mentioned above.

**NOTE:** 1. Make sure to release the failure mode recall function once it is set up, otherwise the unit cannot operate properly.  
2. If the abnormal condition is not deleted from the memory, the last abnormal condition is kept memorized.

※2. Blinking pattern when the indoor unit is abnormal:

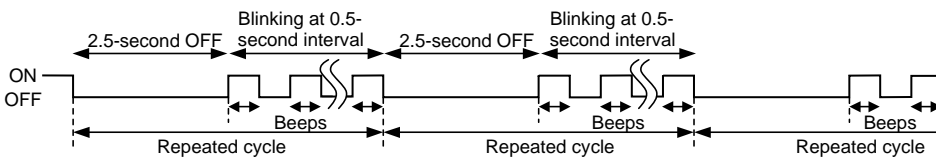

※3. Blinking pattern when the outdoor unit is abnormal:

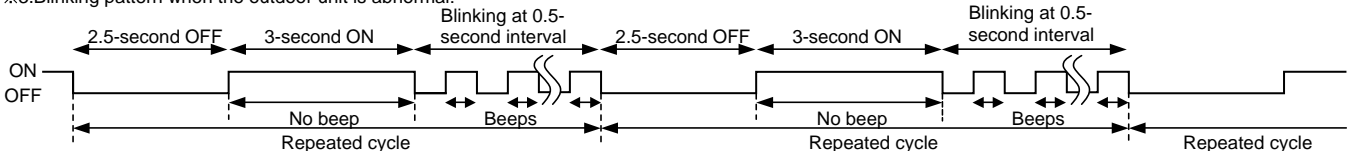

## 2. Flow chart of the detailed outdoor unit failure mode recall function

### Operational procedure

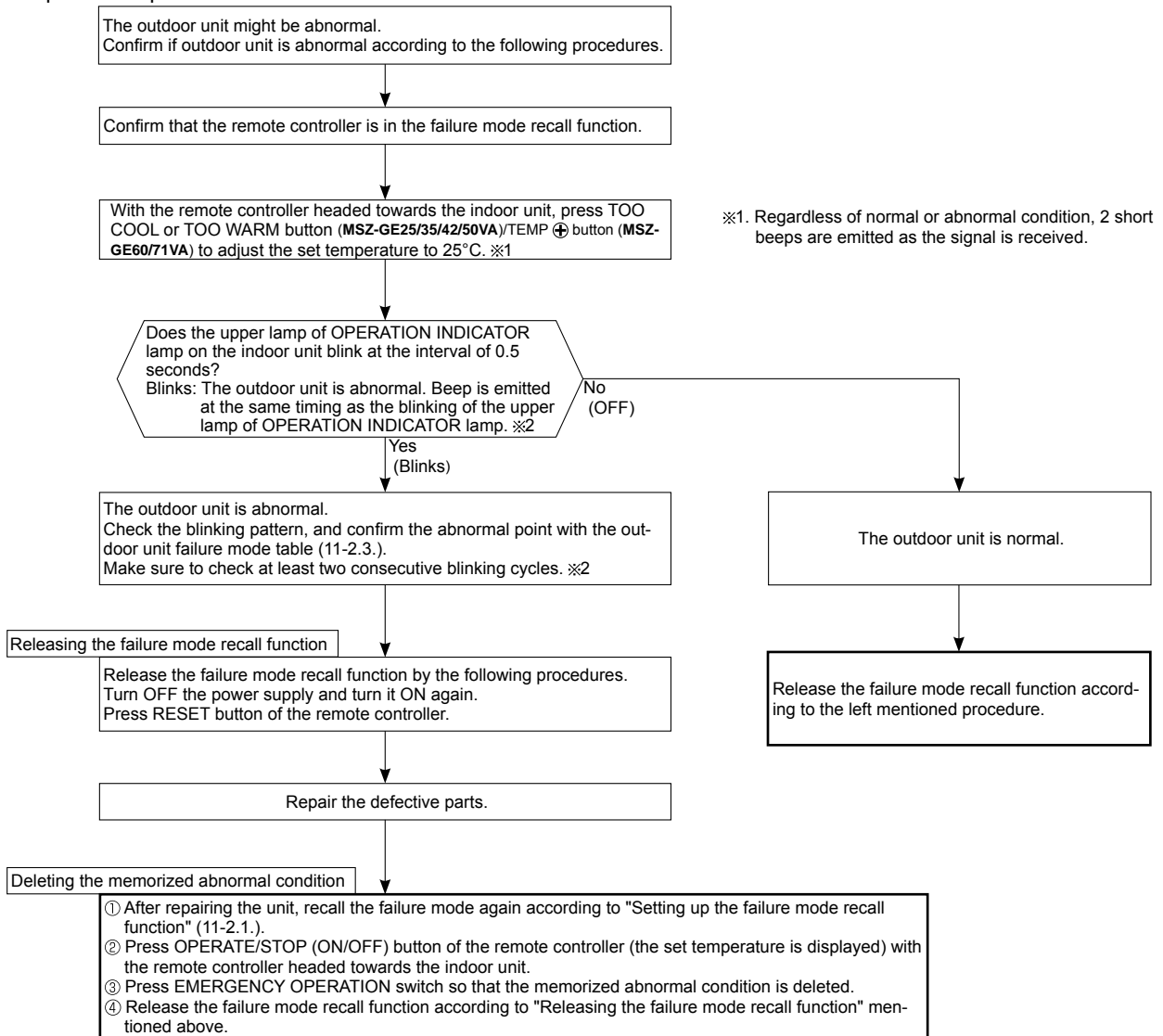

**NOTE:** 1. Make sure to release the failure mode recall function once it is set up, otherwise the unit cannot operate properly.  
2. If the abnormal condition is not deleted from the memory, the last abnormal condition is kept memorized.

※2. Blinking pattern when outdoor unit is abnormal:

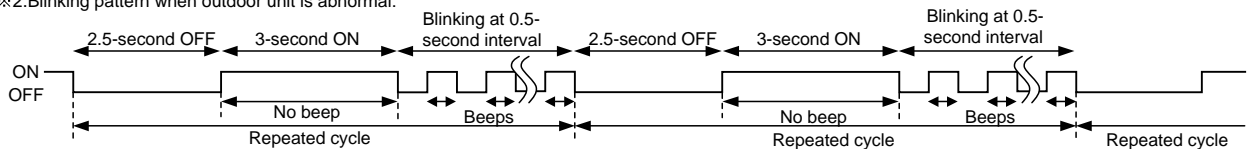

### 3. Outdoor unit failure mode table

The upper lamp of OPERATION INDICATOR lamp (Indoor unit)	Abnormal point (Failure mode / protection)	LED indication (Outdoor P.C. board)	Condition	Correspondence	Indoor/outdoor unit failure mode recall function	Outdoor unit failure mode recall function
OFF	None (Normal)	—	—	—	—	—
2-time flash 2.5 seconds OFF	Outdoor power system	—	Overcurrent protection stop is continuously performed 3 times within 1 minute after the compressor gets started.	<ul style="list-style-type: none"> <li>•Reconnect connectors.</li> <li>•Refer to 11-5. Ⓐ"How to check inverter/compressor".</li> <li>•Check stop valve.</li> </ul>	○	○
3-time flash 2.5 seconds OFF	Discharge temperature thermistor	1-time flash every 2.5 seconds	Thermistor shorts or opens during compressor running.	<ul style="list-style-type: none"> <li>•Refer to 11-5. Ⓒ"Check of outdoor thermistors". Defective outdoor thermistors can be identified by checking the blinking pattern of LED.</li> </ul>	○	○
	Defrost thermistor	—				
	Fin temperature thermistor	3-time flash 2.5 seconds OFF				
	P.C. board temperature thermistor	4-time flash 2.5 seconds OFF				
	Ambient temperature thermistor	2-time flash 2.5 seconds OFF				
	Outdoor heat exchanger temperature thermistor	—				
4-time flash 2.5 seconds OFF	Overcurrent	11-time flash 2.5 seconds OFF	Large current flows into intelligent power module.	<ul style="list-style-type: none"> <li>•Reconnect compressor connector.</li> <li>•Refer to 11-5. Ⓐ"How to check inverter/compressor".</li> <li>•Check stop valve.</li> </ul>	—	○
	Compressor synchronous abnormality (Compressor start-up failure protection)	12-time flash 2.5 seconds OFF	Waveform of compressor current is distorted.	<ul style="list-style-type: none"> <li>•Reconnect compressor connector.</li> <li>•Refer to 11-5. Ⓐ"How to check inverter/compressor".</li> </ul>	—	○
5-time flash 2.5 seconds OFF	Discharge temperature	—	Temperature of discharge temperature thermistor exceeds 116°C, compressor stops. Compressor can restart if discharge temperature thermistor reads 100°C or less 3 minutes later.	<ul style="list-style-type: none"> <li>•Check refrigerant circuit and refrigerant amount.</li> <li>•Refer to 11-5. Ⓒ"Check of LEV".</li> </ul>	—	○
6-time flash 2.5 seconds OFF	High pressure	—	Temperature indoor coil thermistor exceeds 70°C in HEAT mode. Temperature defrost thermistor exceeds 70°C in COOL mode.	<ul style="list-style-type: none"> <li>•Check refrigerant circuit and refrigerant amount.</li> <li>•Check stop valve.</li> </ul>	—	○
7-time flash 2.5 seconds OFF	Fin temperature/ P.C. board temperature	7-time flash 2.5 seconds OFF	Temperature of fin temperature thermistor on the inverter P.C. board exceeds 75 ~ 80°C, or temperature of P.C. board temperature thermistor on the inverter P.C. board exceeds 70 ~ 75°C.	<ul style="list-style-type: none"> <li>•Check around outdoor unit.</li> <li>•Check outdoor unit air passage.</li> <li>•Refer to 11-5. ①"Check of outdoor fan motor".</li> </ul>	—	○
8-time flash 2.5 seconds OFF	Outdoor fan motor	—	Outdoor fan has stopped 3 times in a row within 30 seconds after outdoor fan start-up.	<ul style="list-style-type: none"> <li>•Refer to 11-5. ①"Check of outdoor fan motor".</li> <li>Refer to 11-5. ②"Check of inverter P.C. board".</li> </ul>	—	○
9-time flash 2.5 seconds OFF	Nonvolatile memory data	5-time flash 2.5 seconds OFF	Nonvolatile memory data cannot be read properly.	•Replace the inverter P.C. board.	○	○
	Power module	6-time flash 2.5 seconds OFF	The interphase short circuit occurs in the output of the intelligent power module (IPM). The compressor winding shorts circuit.	•Refer to 11-5. Ⓐ"How to check inverter/compressor".		
10-time flash 2.5 seconds OFF	Discharge temperature	—	Temperature of discharge temperature thermistor has been 50°C or less for 20 minutes.	<ul style="list-style-type: none"> <li>•Refer to 11-5. Ⓒ"Check of LEV".</li> <li>•Check refrigerant circuit and refrigerant amount.</li> </ul>	—	○
11-time flash 2.5 seconds OFF	DC voltage	8-time flash 2.5 seconds OFF	DC voltage of inverter cannot be detected normally.	•Refer to 11-5. Ⓐ"How to check inverter/compressor".	—	○
	Each phase current of compressor	9-time flash 2.5 seconds OFF	Each phase current of compressor cannot be detected normally.			
12-time flash 2.5 seconds OFF	Overcurrent Compressor open-phase	10-time flash 2.5 seconds OFF	Large current flows into intelligent power module (IPM). The open-phase operation of compressor is detected. The interphase short circuit occurs in the output of the intelligent power module (IPM). The compressor winding shorts circuit.	<ul style="list-style-type: none"> <li>•Reconnect compressor connector.</li> <li>•Refer to 11-5. Ⓐ"How to check inverter/compressor".</li> </ul>	—	○
14-time flash 2.5 seconds OFF	Stop valve (Closed valve)	14-time flash 2.5 seconds OFF	Closed valve is detected by compressor current.	•Check stop valve	○	○

**NOTE:** Blinking patterns of this mode differ from the ones of Troubleshooting check table (11-3.).

### 11-3. TROUBLESHOOTING CHECK TABLE

No.	Symptom	LED indication	Abnormal point/ Condition	Condition	Correspondence	
1	Outdoor unit does not operate.	1-time flash every 2.5 seconds	Outdoor power system	Overcurrent protection stop is continuously performed 3 times within 1 minute after the compressor gets started.	<ul style="list-style-type: none"> <li>•Reconnect connector of compressor.</li> <li>•Refer to 11-5.Ⓐ "How to check inverter/compressor".</li> <li>•Check stop valve.</li> </ul>	
2			Outdoor thermistors	Discharge temperature thermistor, fin temperature thermistor, defrost thermistor, P.C. board temperature thermistor, outdoor heat exchanger temperature thermistor or ambient temperature thermistor shorts or opens during compressor running.	•Refer to 11-5.Ⓒ "Check of outdoor thermistors".	
3			Outdoor control system	Nonvolatile memory data cannot be read properly. (The upper lamp of OPERATION INDICATOR lamp of the indoor unit lights up or flashes 7-time.)	•Replace inverter P.C. board.	
4		6-time flash 2.5 seconds OFF	Serial signal	The communication fails between the indoor and outdoor unit for 3 minutes.	•Refer to 11-5.Ⓓ "How to check miswiring and serial signal error."	
5		11-time flash 2.5 seconds OFF	Stop valve/ Closed valve	Closed valve is detected by compressor current.	•Check stop valve.	
6		14-time flash 2.5 seconds OFF	Outdoor unit (Other abnormality)	Outdoor unit is defective.	•Refer to 11-2.2. "Flow chart of the detailed outdoor unit failure mode recall function".	
7	'Outdoor unit stops and restarts 3 minutes later' is repeated.	2-time flash 2.5 seconds OFF	Overcurrent protection	Large current flows into intelligent power module.	<ul style="list-style-type: none"> <li>•Reconnect connector of compressor.</li> <li>•Refer to 11-5.Ⓐ "How to check inverter/compressor".</li> <li>•Check stop valve.</li> </ul>	
8		3-time flash 2.5 seconds OFF	Discharge temperature overheat protection	Temperature of discharge temperature thermistor exceeds 116°C, compressor stops. Compressor can restart if discharge temperature thermistor reads 100°C or less 3 minutes later.	<ul style="list-style-type: none"> <li>•Check refrigerant circuit and refrigerant amount.</li> <li>•Refer to 11-5.Ⓔ "Check of LEV".</li> </ul>	
9		4-time flash 2.5 seconds OFF	Fin temperature /P.C. board temperature thermistor overheat protection	Temperature of fin temperature thermistor on the heat sink exceeds 75 ~ 80°C or temperature of P.C. board temperature thermistor on the inverter P.C. board exceeds 70 ~ 75°C.	<ul style="list-style-type: none"> <li>•Check around outdoor unit.</li> <li>•Check outdoor unit air passage.</li> <li>•Refer to 11-5.Ⓛ "Check of outdoor fan motor".</li> </ul>	
10		5-time flash 2.5 seconds OFF	High pressure protection	Indoor coil thermistor exceeds 70°C in HEAT mode. Defrost thermistor exceeds 70°C in COOL mode.	<ul style="list-style-type: none"> <li>•Check refrigerant circuit and refrigerant amount.</li> <li>•Check stop valve.</li> </ul>	
11		8-time flash 2.5 seconds OFF	Compressor synchronous abnormality	The waveform of compressor current is distorted.	<ul style="list-style-type: none"> <li>•Reconnect connector of compressor.</li> <li>•Refer to 11-5.Ⓐ "How to check inverter/compressor".</li> </ul>	
12		10-time flash 2.5 seconds OFF	Outdoor fan motor	Outdoor fan has stopped 3 times in a row within 30 seconds after outdoor fan start-up.	<ul style="list-style-type: none"> <li>•Refer to 11-5.Ⓜ "Check of outdoor fan motor."</li> <li>•Refer to 11-5.Ⓨ "Check of inverter P.C. board."</li> </ul>	
13		12-time flash 2.5 seconds OFF	Each phase current of compressor	Each phase current of compressor cannot be detected normally.	•Refer to 11-5.Ⓐ "How to check inverter/compressor".	
14		13-time flash 2.5 seconds OFF	DC voltage	DC voltage of inverter cannot be detected normally.	•Refer to 11-5.Ⓐ "How to check inverter/compressor".	
15		Outdoor unit operates.	1-time flash 2.5 seconds OFF	Frequency drop by current protection	Current from power outlet is nearing breaker capacity. PFC module stops due to overcurrent. <b>(MUZ-GE60/71)</b>	The unit is normal, but check the following.
16			3-time flash 2.5 seconds OFF	Frequency drop by high pressure protection	Temperature of indoor coil thermistor exceeds 55°C in HEAT mode, compressor frequency lowers.	<ul style="list-style-type: none"> <li>•Check if indoor filters are clogged.</li> <li>•Check if refrigerant is short.</li> <li>•Check if indoor/outdoor unit air circulation is short cycled.</li> </ul>
	Frequency drop by defrosting in COOL mode			Indoor coil thermistor reads 8°C or less in COOL mode, compressor frequency lowers.		
17	4-time flash 2.5 seconds OFF	Frequency drop by discharge temperature protection	Temperature of discharge temperature thermistor exceeds 111°C, compressor frequency lowers.	<ul style="list-style-type: none"> <li>•Check refrigerant circuit and refrigerant amount.</li> <li>•Refer to 11-5.Ⓔ "Check of LEV".</li> <li>•Refer to 11-5.Ⓒ "Check of outdoor thermistors".</li> </ul>		
18	Outdoor unit operates.	7-time flash 2.5 seconds OFF	Low discharge temperature protection	Temperature of discharge temperature thermistor has been 50°C or less for 20 minutes.	<ul style="list-style-type: none"> <li>•Refer to 11-5.Ⓔ "Check of LEV".</li> <li>•Check refrigerant circuit and refrigerant amount.</li> </ul>	
19		8-time flash 2.5 seconds OFF	MUZ-GE25/35/42/50 PAM protection PAM: Pulse Amplitude Modulation	The overcurrent flows into IGBT (Insulated Gate Bipolar transistor: TR821) or the bus-bar voltage reaches 320 V or more, PAM stops and restarts.	This is not malfunction. PAM protection will be activated in the following cases: 1 Instantaneous power voltage drop. (Short time power failure) 2 When the power supply voltage is high.	
			MUZ-GE60/71 Zero cross detecting circuit	Zero cross signal for PAM control cannot be detected.		
20	9-time flash 2.5 seconds OFF	Inverter check mode	The connector of compressor is disconnected, inverter check mode starts.	•Check if the connector of the compressor is correctly connected. Refer to 11-5.Ⓐ "How to check inverter/compressor".		

NOTE: 1. The location of LED is illustrated at the right figure. Refer to 11-6.1.  
2. LED is lighted during normal operation.

The flashing frequency shows the number of times  
(Example) When the flashing frequency is "2".

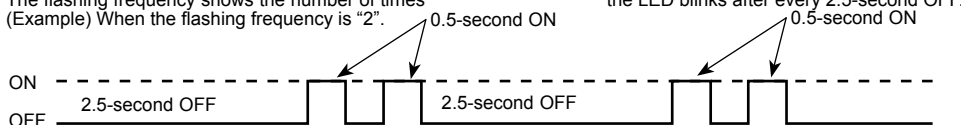

Inverter P.C. board

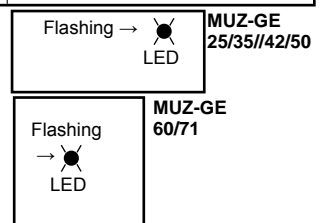

#### 11-4. TROUBLE CRITERION OF MAIN PARTS

#### MUZ-GE25VA MUZ-GE25VAH MUZ-GE35VA MUZ-GE35VAH MUZ-GE42VA MUZ-GE42VAH MUZ-GE50VA MUZ-GE50VAH MUZ-GE60VA MUZ-GE71VA

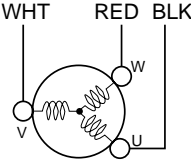
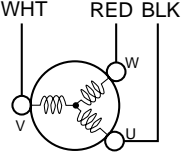
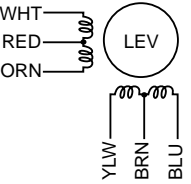
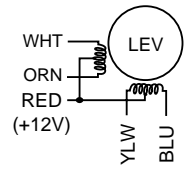
Part name	Check method and criterion	Figure																
Defrost thermistor (RT61) Fin temperature thermistor (RT64) Ambient temperature thermistor (RT65) Outdoor heat exchanger temperature thermistor (RT68)	Measure the resistance with a tester.  Refer to 11-6. "Test point diagram and voltage", 1. "Inverter P.C. board", for the chart of thermistor.																	
Discharge temperature thermistor (RT62)	Measure the resistance with a tester. Before measurement, hold the thermistor with your hands to warm it up.  Refer to 11-6. "Test point diagram and voltage", 1. "Inverter P.C. board", for the chart of thermistor.																	
Compressor	Measure the resistance between terminals using a tester. (Temperature: -10 ~ 40°C) <table border="1"> <thead> <tr> <th rowspan="2"></th> <th colspan="4">Normal (Ω)</th> </tr> <tr> <th>MUZ-GE25</th> <th>MUZ-GE35</th> <th>MUZ-GE42/50/60</th> <th>MUZ-GE71</th> </tr> </thead> <tbody> <tr> <td>U-V</td> <td rowspan="3">1.36 ~ 1.93</td> <td rowspan="3">1.52 ~ 2.17</td> <td rowspan="3">0.78 ~ 1.11</td> <td rowspan="3">0.83 ~ 1.18</td> </tr> <tr> <td>U-W</td> </tr> <tr> <td>V-W</td> </tr> </tbody> </table>		Normal (Ω)				MUZ-GE25	MUZ-GE35	MUZ-GE42/50/60	MUZ-GE71	U-V	1.36 ~ 1.93	1.52 ~ 2.17	0.78 ~ 1.11	0.83 ~ 1.18	U-W	V-W	
	Normal (Ω)																	
	MUZ-GE25	MUZ-GE35	MUZ-GE42/50/60	MUZ-GE71														
U-V	1.36 ~ 1.93	1.52 ~ 2.17	0.78 ~ 1.11	0.83 ~ 1.18														
U-W																		
V-W																		
Outdoor fan motor	Measure the resistance between lead wires using a tester. (Temperature: -10 ~ 40°C) <table border="1"> <thead> <tr> <th rowspan="2">Color of lead wire</th> <th colspan="3">Normal (Ω)</th> </tr> <tr> <th>MUZ-GE25/35</th> <th>MUZ-GE42</th> <th>MUZ-GE50/60/71</th> </tr> </thead> <tbody> <tr> <td>RED - BLK</td> <td rowspan="3">29 ~ 42</td> <td rowspan="3">11 ~ 16</td> <td rowspan="3">12 ~ 17</td> </tr> <tr> <td>BLK - WHT</td> </tr> <tr> <td>WHT - RED</td> </tr> </tbody> </table>	Color of lead wire	Normal (Ω)			MUZ-GE25/35	MUZ-GE42	MUZ-GE50/60/71	RED - BLK	29 ~ 42	11 ~ 16	12 ~ 17	BLK - WHT	WHT - RED				
Color of lead wire	Normal (Ω)																	
	MUZ-GE25/35	MUZ-GE42	MUZ-GE50/60/71															
RED - BLK	29 ~ 42	11 ~ 16	12 ~ 17															
BLK - WHT																		
WHT - RED																		
R. V. coil (21S4)	Measure the resistance using a tester. (Temperature: -10 ~ 40°C) <table border="1"> <thead> <tr> <th>Normal (kΩ)</th> </tr> </thead> <tbody> <tr> <td>1.19 ~ 1.78</td> </tr> </tbody> </table>	Normal (kΩ)	1.19 ~ 1.78															
Normal (kΩ)																		
1.19 ~ 1.78																		
Expansion valve coil (LEV)	Measure the resistance using a tester. (Temperature: -10 ~ 40°C) <b>MUZ-GE25/35/42/50</b> <table border="1"> <thead> <tr> <th>Color of lead wire</th> <th>Normal (Ω)</th> </tr> </thead> <tbody> <tr> <td>WHT - RED</td> <td rowspan="4">37 ~ 54</td> </tr> <tr> <td>RED - ORN</td> </tr> <tr> <td>YLW - BRN</td> </tr> <tr> <td>BRN - BLU</td> </tr> </tbody> </table>	Color of lead wire	Normal (Ω)	WHT - RED	37 ~ 54	RED - ORN	YLW - BRN	BRN - BLU										
	Color of lead wire	Normal (Ω)																
WHT - RED	37 ~ 54																	
RED - ORN																		
YLW - BRN																		
BRN - BLU																		
Measure the resistance using a tester. (Temperature: -10 ~ 40°C) <b>MUZ-GE60/71</b> <table border="1"> <thead> <tr> <th>Color of lead wire</th> <th>Normal (Ω)</th> </tr> </thead> <tbody> <tr> <td>RED - ORN</td> <td rowspan="4">37 ~ 54</td> </tr> <tr> <td>RED - WHT</td> </tr> <tr> <td>RED - BLU</td> </tr> <tr> <td>RED - YLW</td> </tr> </tbody> </table>	Color of lead wire	Normal (Ω)	RED - ORN	37 ~ 54	RED - WHT	RED - BLU	RED - YLW											
Color of lead wire	Normal (Ω)																	
RED - ORN	37 ~ 54																	
RED - WHT																		
RED - BLU																		
RED - YLW																		
Defrost heater <b>MUZ-GE•VAH</b>	Measure the resistance using a tester. (Temperature: -10 ~ 40°C) <table border="1"> <thead> <tr> <th>Normal (Ω)</th> </tr> </thead> <tbody> <tr> <td>349 ~ 428</td> </tr> </tbody> </table>	Normal (Ω)	349 ~ 428															
Normal (Ω)																		
349 ~ 428																		



### 11-5. TROUBLESHOOTING FLOW

#### Ⓐ How to check inverter/compressor

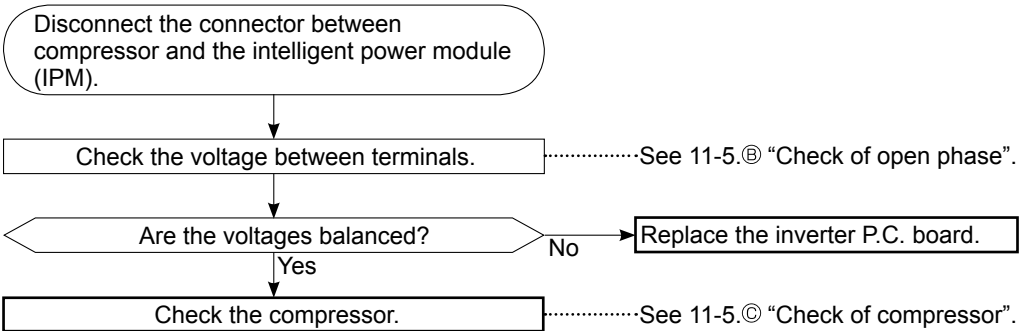

#### Ⓑ Check of open phase

- With the connector between the compressor and the intelligent power module disconnected, activate the inverter and check if the inverter is normal by measuring **the balance of voltage** between the terminals.

Output voltage is 50 - 130 V. (The voltage may differ according to the tester.)

<< Operation method >>

Start cooling or heating operation by pressing EMERGENCY OPERATION switch on the indoor unit. (TEST RUN OPERATION: Refer to 8-3.)

<< Measurement point >>

At 3 points

BLK (U)-WHT (V) ※ Measure AC voltage between the lead wires at 3 points.

BLK (U)-RED (W)

WHT(V)-RED (W)

- NOTE:**
1. Output voltage varies according to power supply voltage.
  2. Measure the voltage by analog type tester.
  3. During this check, LED of the inverter P.C. board flashes 9 times. (Refer to 11-6.1.)

#### Ⓒ Check of compressor

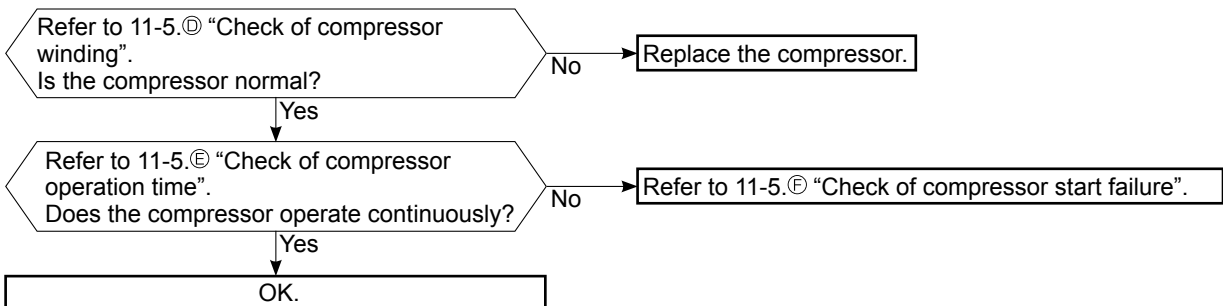

### D Check of compressor winding

- Disconnect the connector between the compressor and intelligent power module, and measure the resistance between the compressor terminals.

<<Measurement point>>

at 3 points

BLK-WHT

BLK-RED

WHT-RED

※ Measure the resistance between the lead wires at 3 points.

<<Judgement>>

Refer to 11-4.

0 [Ω] .....Abnormal [short]

Infinite [Ω] .....Abnormal [open]

**NOTE:** Be sure to zero the ohmmeter before measurement.

### E Check of compressor operation time

- Connect the compressor and activate the inverter. Then measure the time until the inverter stops due to over current.

<<Operation method>>

Start heating or cooling operation by pressing EMERGENCY OPERATION switch on the indoor unit. (TEST RUN OPERATION: Refer to 8-3.)

<<Measurement>>

Measure the time from the start of compressor to the stop of compressor due to overcurrent.

<<Judgement>>

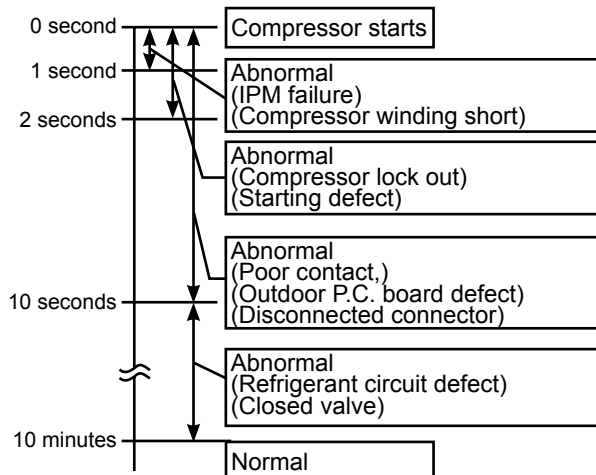

### F Check of compressor start failure

Confirm that ①~④ is normal.

•Electrical circuit check

①. Contact of the compressor connector

②. Output voltage of inverter P.C. board and balance of them (See 11-5.③)

③. Direct current voltage between DB61(+) and (-) (**MUZ-GE25/35/42/50**)/JP715(+) and JP30(-) (**MUZ-GE60/71**) on the inverter P.C. board

④. Voltage between outdoor terminal block S1-S2

Does the compressor run for 10 seconds or more after it starts?

Yes

Check the refrigerant circuit.  
Check the stop valve.

No

After the compressor is heated with a drier, does the compressor start? ※1

No

Replace the compressor.

Yes

Compressor start failure. Activate pre-heat control.  
(Refer to 10-2. "PRE-HEAT CONTROL SETTING")

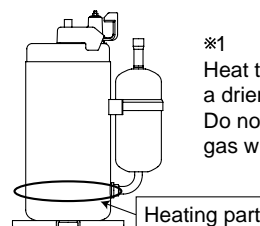

※1 Heat the compressor with a drier for about 20 minutes. Do not recover refrigerant gas while heating.



### G Check of outdoor thermistors

Disconnect the connector of thermistor in the outdoor P.C. board (see below table), and measure the resistance of thermistor.

Is the resistance of thermistor normal?  
(Refer to 11-6.1.)

No

Replace the thermistor except RT64.  
When RT64 is abnormal, replace the inverter P.C. board.

Yes

Reconnect the connector of thermistor.  
Turn ON the power supply and press EMERGENCY OPERATION switch.

Does the unit operate for 10 minutes or more  
without showing thermistor abnormality?

No

Replace the inverter P.C. board.

Yes

OK.  
(Cause is poor contact.)

#### MUZ-GE25VA MUZ-GE35VA MUZ-GE42VA MUZ-GE50VA

Thermistor	Symbol	Connector, Pin No.	Board
Defrost	RT61	Between CN641 pin1 and pin2	Inverter P.C. board
Discharge temperature	RT62	Between CN641 pin3 and pin4	
Fin temperature	RT64	Between CN642 pin1 and pin2	
Ambient temperature	RT65	Between CN643 pin1 and pin2	
Outdoor heat exchanger temperature	RT68	Between CN644 pin1 and pin3	

#### MUZ-GE60VA MUZ-GE71VA

Thermistor	Symbol	Connector, Pin No.	Board
Defrost	RT61	Between CN671 pin1 and pin2	Inverter P.C. board
Discharge temperature	RT62	Between CN671 pin3 and pin4	
Fin temperature	RT64	Between CN673 pin1 and pin2	
Ambient temperature	RT65	Between CN672 pin1 and pin2	
Outdoor heat exchanger temperature	RT68	Between CN671 pin5 and pin6	

### H Check of R.V. coil

\* First of all, measure the resistance of R.V. coil to check if the coil is defective. Refer to 11-4.

\* In case CN721 (MUZ-GE25/35/42/50)/CN602 (MUZ-GE60/71) is disconnected or R.V. coil is open, voltage is generated between the terminal pins of the connector although no signal is being transmitted to R.V. coil.  
Check if CN721 (MUZ-GE25/35/42/50)/CN602 (MUZ-GE60/71) is connected.

#### Unit operates COOL mode even if it is set to HEAT mode.

Disconnect connector between the compressor and the intelligent power module.  
Turn ON the power supply and press EMERGENCY OPERATION switch twice (HEAT mode).

Is there 230 VAC between CN721 (MUZ-GE25/35/42/50)/CN602 (MUZ-GE60/71) ① and ② on the inverter P.C. board 3 minutes after the power supply is turned ON?

No

Replace the inverter P.C. board.

Yes

Replace the 4-way valve.

#### Unit operates HEAT mode even if it is set to COOL mode.

Disconnect connector between the compressor and the intelligent power module.  
Turn ON the power supply and press EMERGENCY OPERATION switch once (COOL mode).

Is there 230 VAC between CN721 (MUZ-GE25/35/42/50)/CN602 (MUZ-GE60/71) ① and ② on the inverter P.C. board 3 minutes after the power supply is turned ON?

Yes

Replace the inverter P.C. board.

No

Replace the 4-way valve.



**① Check of outdoor fan motor**

**MUZ-GE25VA MUZ-GE25VAH MUZ-GE35VA MUZ-GE35VAH MUZ-GE42VA MUZ-GE42VAH**

Disconnect CN932 from the inverter P.C. board, and measure the resistance of the outdoor fan motor.

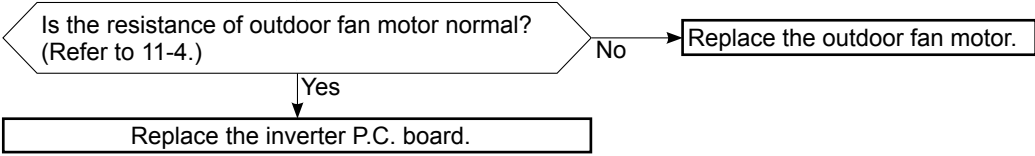

**MUZ-GE50VA MUZ-GE50VAH MUZ-GE60VA MUZ-GE71VA**

Disconnect the connectors CN931 and CN932 from the inverter P.C. board. Check the connection between the connector CN931 and CN932.

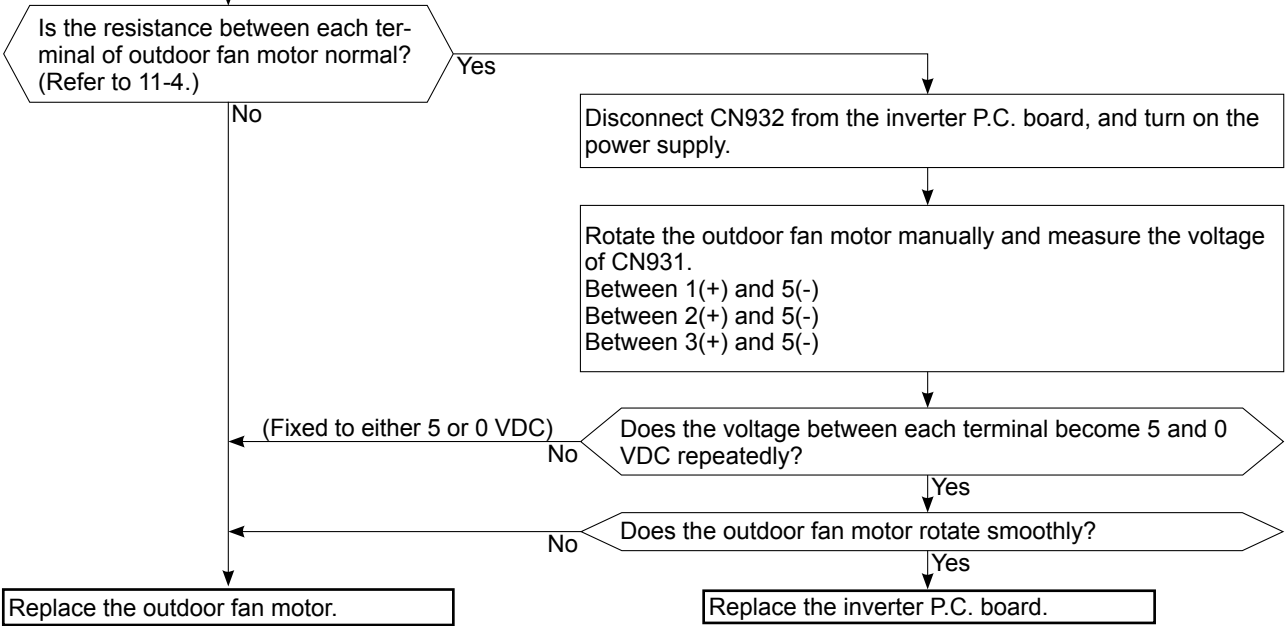

**J Check of power supply**

**MUZ-GE25VA MUZ-GE25VAH MUZ-GE35VA MUZ-GE35VAH MUZ-GE42VA MUZ-GE42VAH MUZ-GE50VA MUZ-GE50VAH**

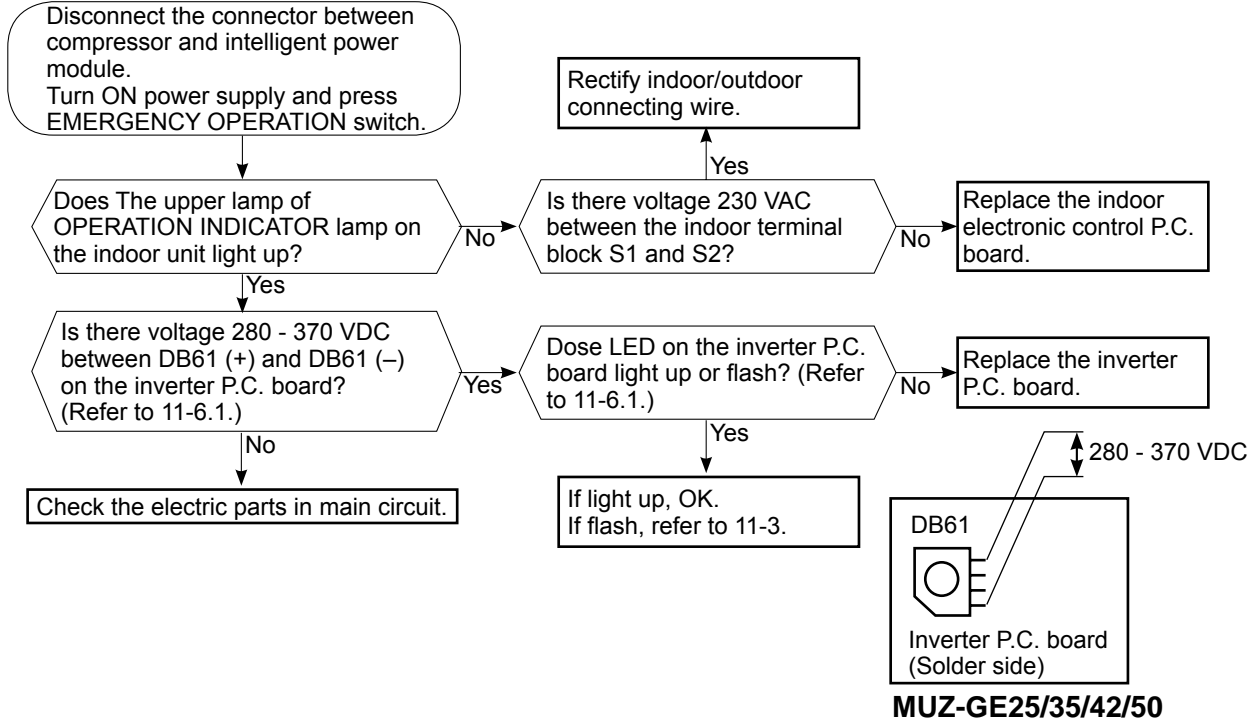

**MUZ-GE60VA MUZ-GE71VA**

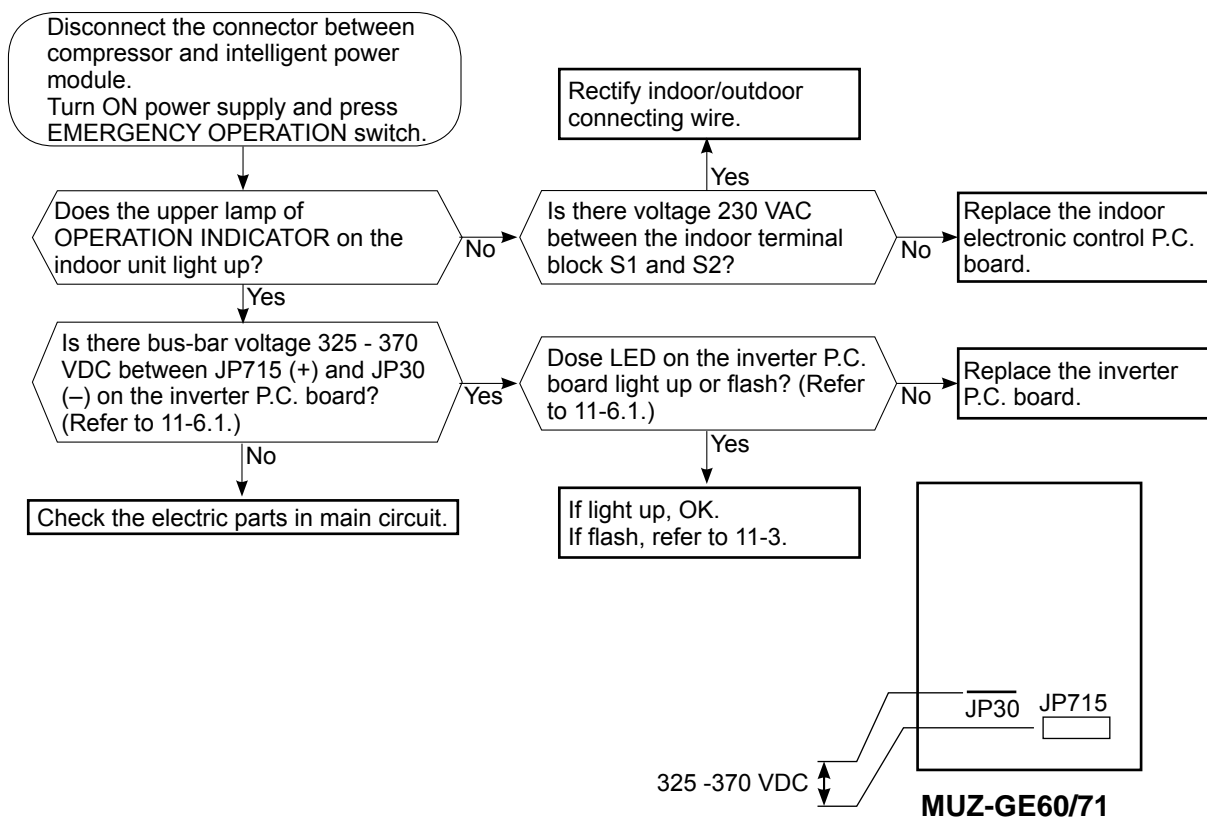

## Ⓚ Check of LEV (Expansion valve)

Turn ON the power supply.

<Preparation of the remote controller>

① While pressing both OPERATION SELECT button and TOO COOL button (**MSZ-GE25/35/42/50VA**)/TEMP  $\oplus$  button (**MSZ-GE60/71VA**) on the remote controller at the same time, press RESET button.

② First, release RESET button.

And release the other two buttons after all LCD except the set temperature in operation display section of the remote controller is displayed after 3 seconds.

**MUZ-GE25VA MUZ-GE42VA**  
**MUZ-GE35VA MUZ-GE50VA**

**MUZ-GE60VA**  
**MUZ-GE71VA**

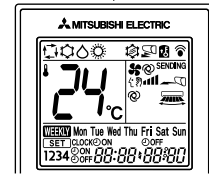
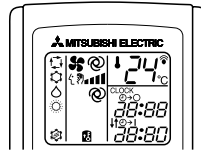
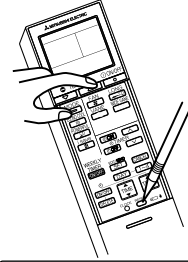
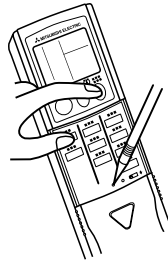

Press OPERATE/STOP (ON/OFF) button of the remote controller (the set temperature is displayed) with the remote controller headed towards the indoor unit. ※1

Expansion valve operates in full-opening direction.

Do you hear the expansion valve "click, click....." ?  
Do you feel the expansion valve vibrate on touching it ?

Yes → OK

No

Is LEV coil properly fixed to the expansion valve?

No

Properly fix the LEV coil to the expansion valve.

Yes

Does the resistance of LEV coil have the characteristics? (Refer to 11-4.)

Yes

Measure each voltage between connector pins of CN724 on the inverter P.C. board.  
1. Pin③(-) — Pin①(+)  
2. Pin④(-) — Pin①(+)  
3. Pin⑤(-) — Pin①(+)  
4. Pin⑥(-) — Pin①(+)  
Is there about 3 - 5 VAC between each?  
**NOTE:** Measure the voltage by an analog tester.

No

Replace the inverter P.C. board.

Replace the LEV coil.

Yes

Replace the expansion valve.

※1. Regardless of normal or abnormal condition, a short beep is emitted once the signal is received.

**NOTE:** After check of LEV, do the undermentioned operations.

1. Turn OFF the power supply and turn it ON again.
2. Press RESET button on the remote controller.

**L Check of inverter P.C. board**

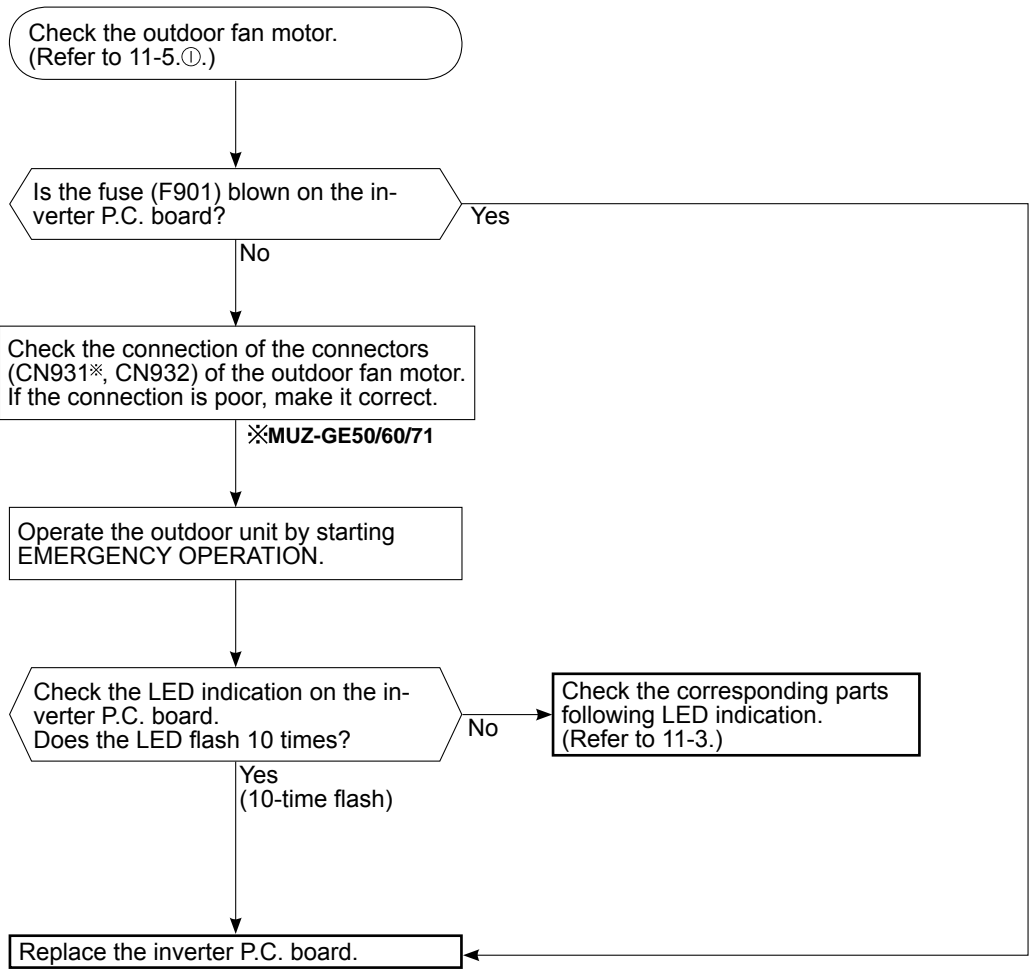

## M How to check miswiring and serial signal error

MUZ-GE25VA MUZ-GE25VAH MUZ-GE35VA MUZ-GE35VAH MUZ-GE42VA MUZ-GE42VAH  
 MUZ-GE50VA MUZ-GE50VAH

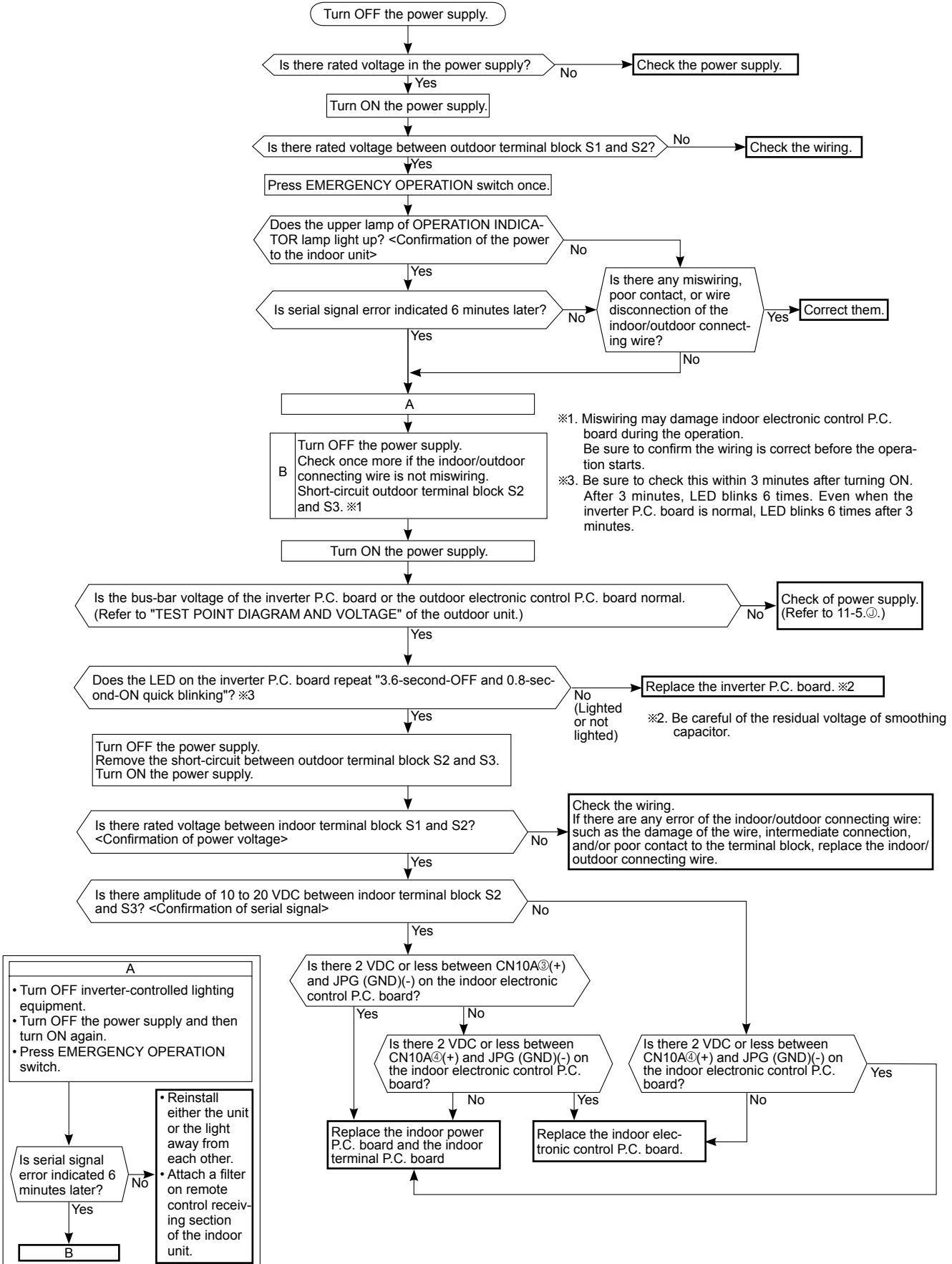

**MUZ-GE60VA MUZ-GE71VA**

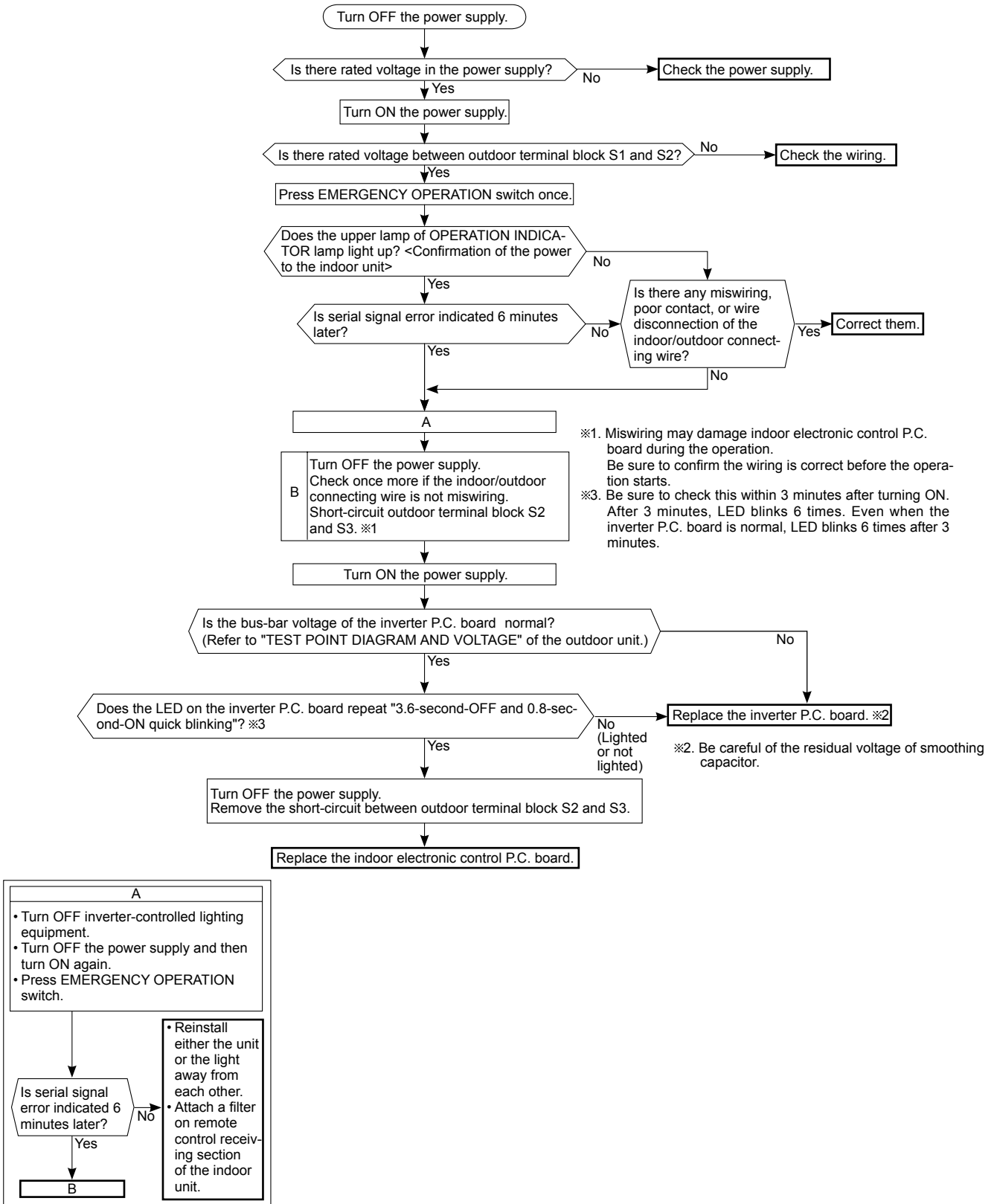

## Ⓝ Electromagnetic noise enters into TV sets or radios

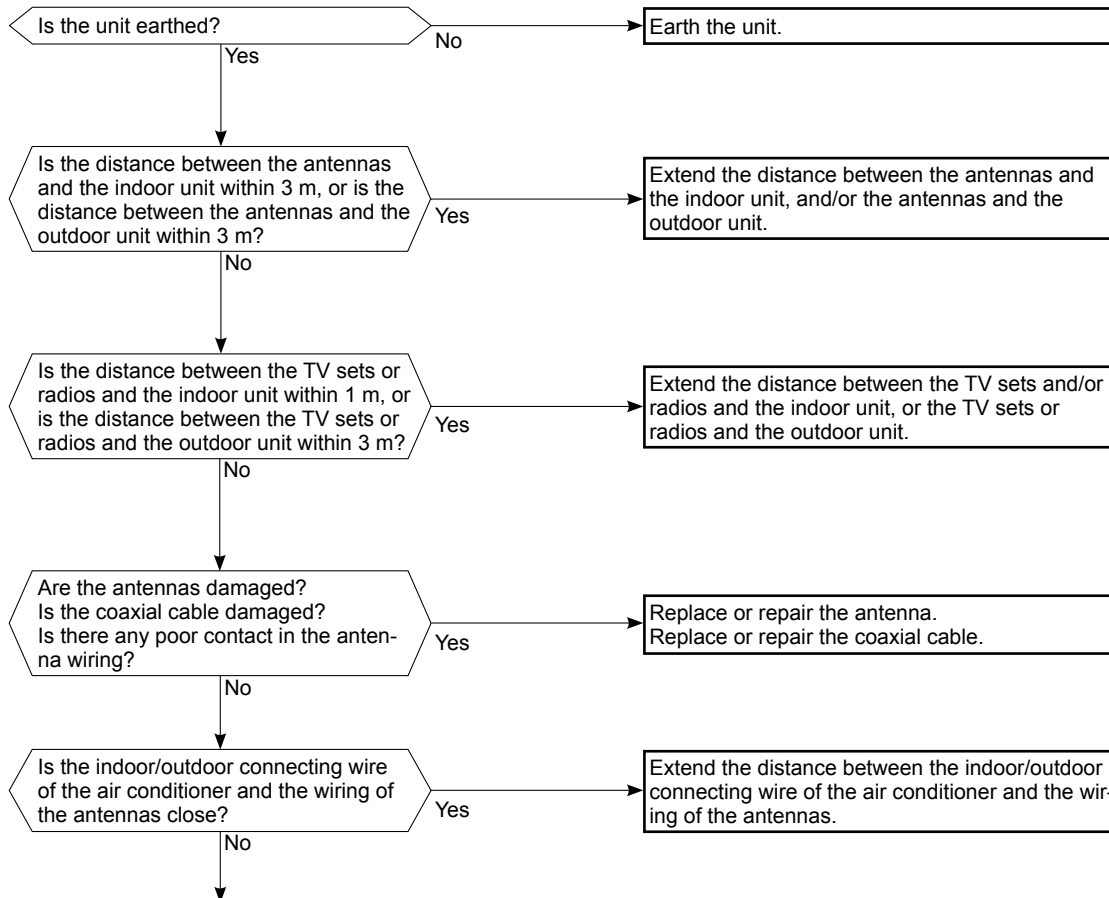

Even if all of the above conditions are fulfilled, the electromagnetic noise may enter, depending on the electric field strength or the installation condition (combination of specific conditions such as antennas or wiring). Check the following before asking for service.

1. Devices affected by the electromagnetic noise  
TV sets, radios (FM/AM broadcast, shortwave)
2. Channel, frequency, broadcast station affected by the electromagnetic noise
3. Channel, frequency, broadcast station unaffected by the electromagnetic noise
4. Layout of:  
indoor/outdoor unit of the air conditioner, indoor/outdoor wiring, earth wire, antennas, wiring from antennas, receiver
5. Electric field intensity of the broadcast station affected by the electromagnetic noise
6. Presence or absence of amplifier such as booster
7. Operation condition of air conditioner when the electromagnetic noise enters in
  - 1) Turn OFF the power supply once, and then turn ON the power supply. In this situation, check for the electromagnetic noise.
  - 2) Within 3 minutes after turning ON the power supply, press OPERATE/STOP (ON/OFF) button on the remote controller for power ON, and check for the electromagnetic noise.
  - 3) After a short time (3 minutes later after turning ON), the outdoor unit starts running. During operation, check for the electromagnetic noise.
  - 4) Press OPERATE/STOP (ON/OFF) button on the remote controller for power OFF, when the outdoor unit stops but the indoor/outdoor communication still runs on. In this situation, check for the electromagnetic noise.





**⊙ Check of defrost heater**

**MUZ-GE•VAH**

Check the following points before checking electric continuity.

- 1. Does the resistance of ambient temperature thermistor have the characteristics? Refer to 11-6.1.
- 2. Is the resistance of defrost heater normal? Refer to 11-4.
- 3. Does the heater protector remain conducted (not open)?
- 4. Are both ambient temperature thermistor and circuit of defrost heater securely connected to connectors?

In HEAT mode, for more than 5 minutes, let the ambient temperature thermistor continue to read 5°C or below, and let the defrost thermistor continue to read -1°C or below.

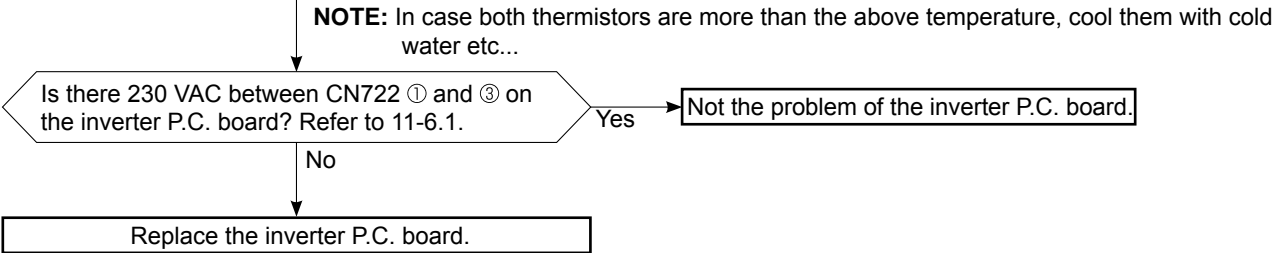

# 11-6. TEST POINT DIAGRAM AND VOLTAGE

## 1. Inverter P.C. board

**MUZ-GE25VA MUZ-GE25VAH MUZ-GE35VA MUZ-GE35VAH  
MUZ-GE42VA MUZ-GE42VAH**

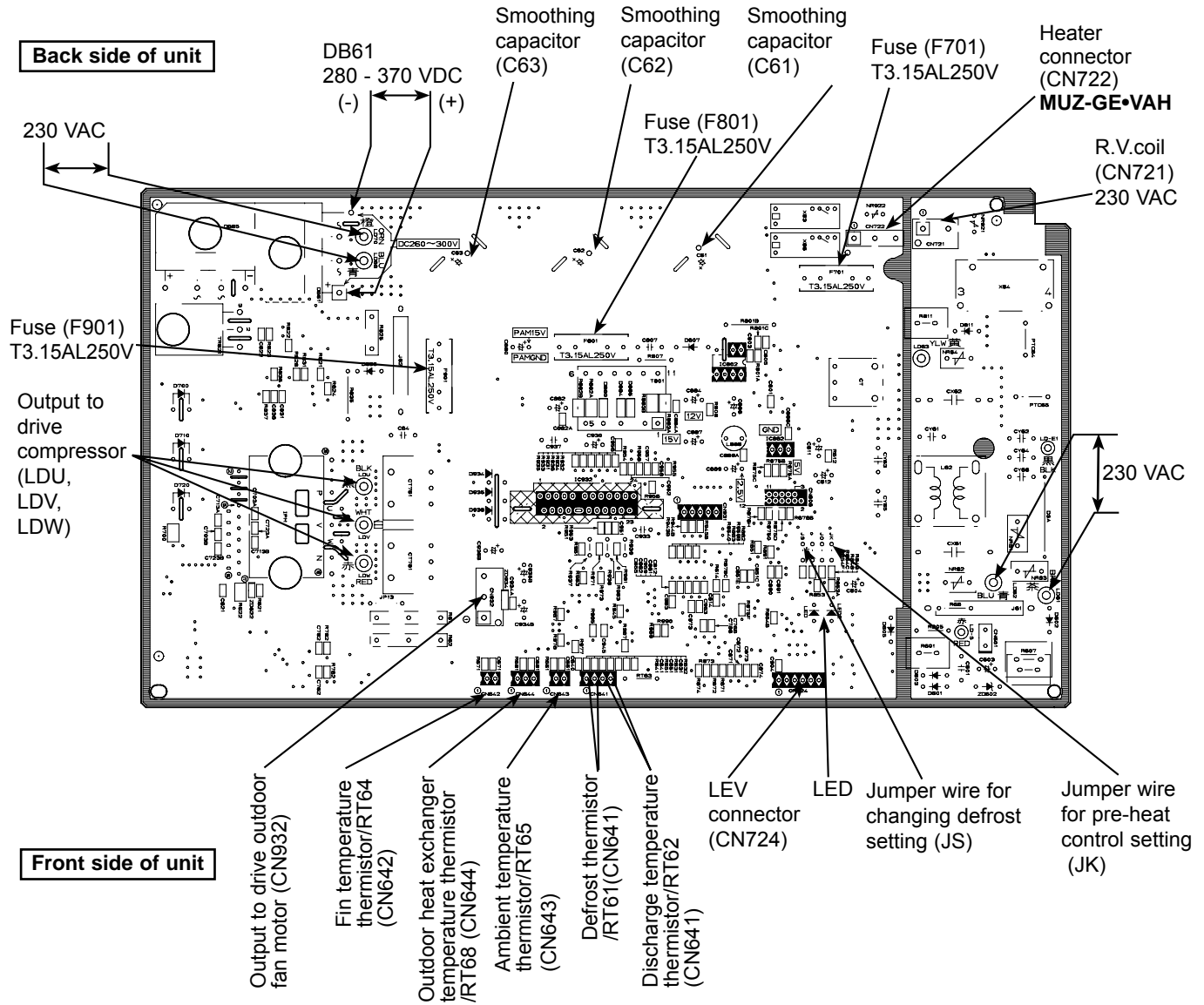

Defrost thermistor(RT61)  
Ambient temperature thermistor(RT65)  
Outdoor heat exchanger temperature thermistor(RT68)

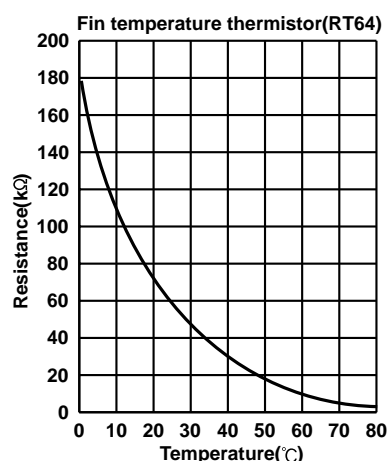
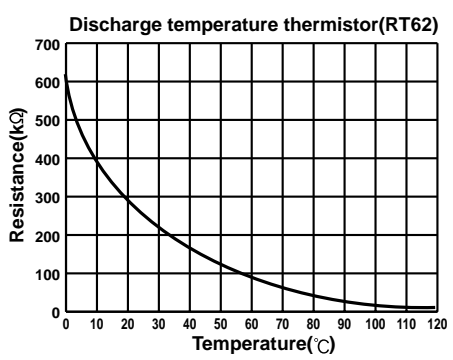
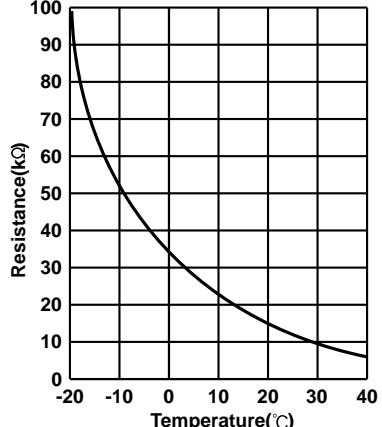

# MUZ-GE50VA MUZ-GE50VAH

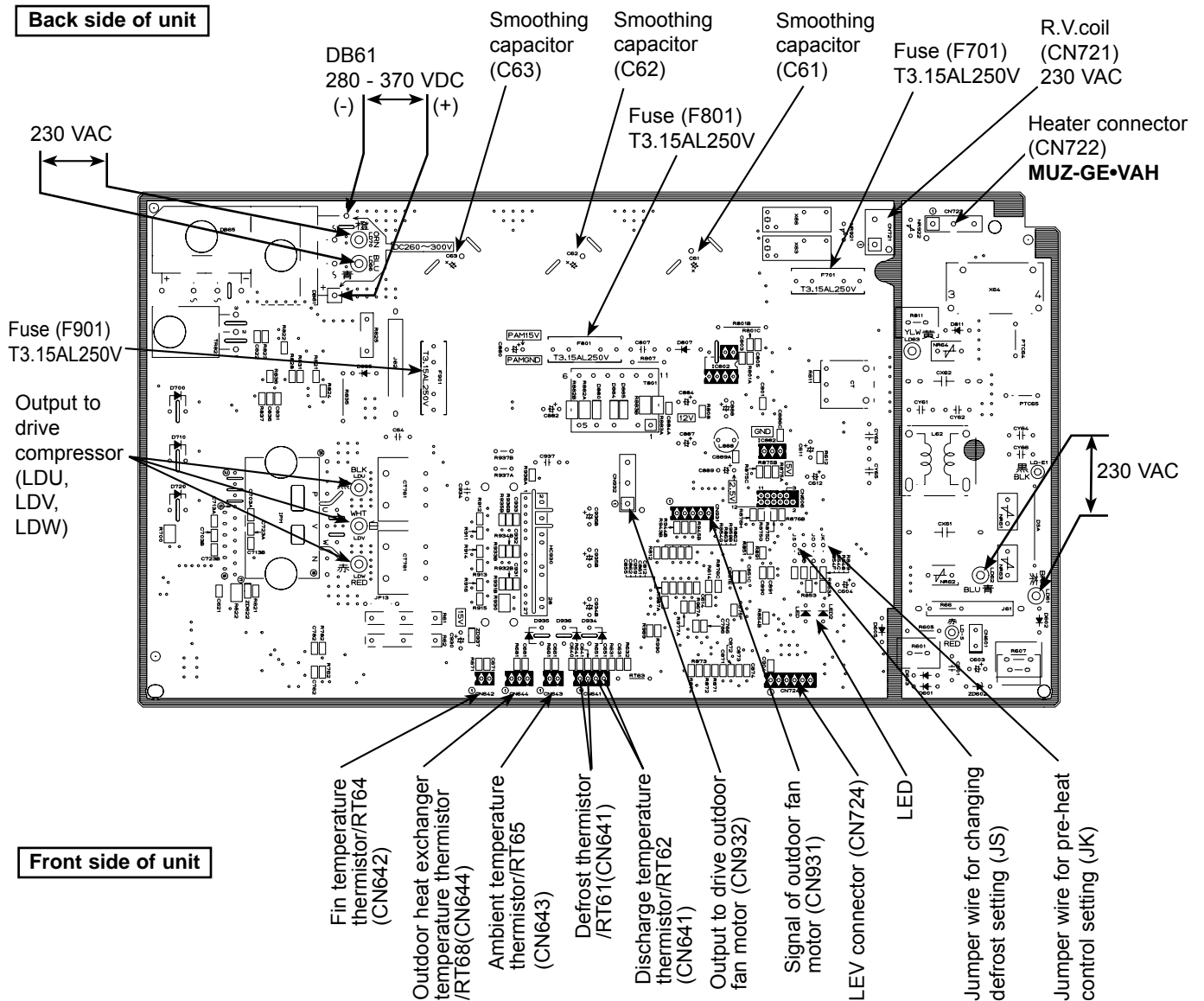

Defrost thermistor(RT61)  
Ambient temperature thermistor(RT65)  
Outdoor heat exchanger temperature thermistor(RT68)

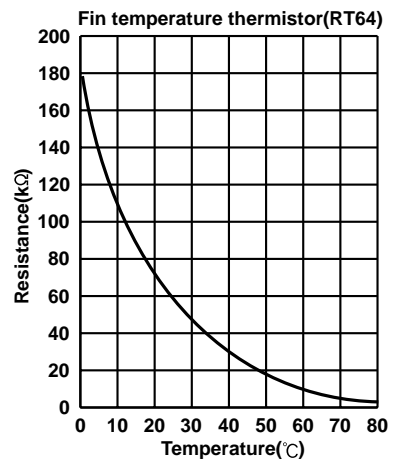
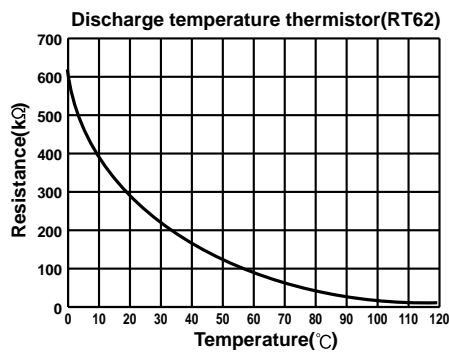
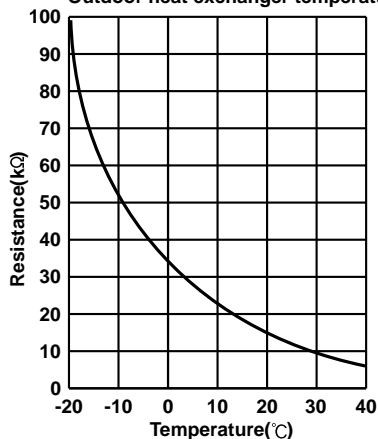

# MUZ-GE60VA MUZ-GE71VA

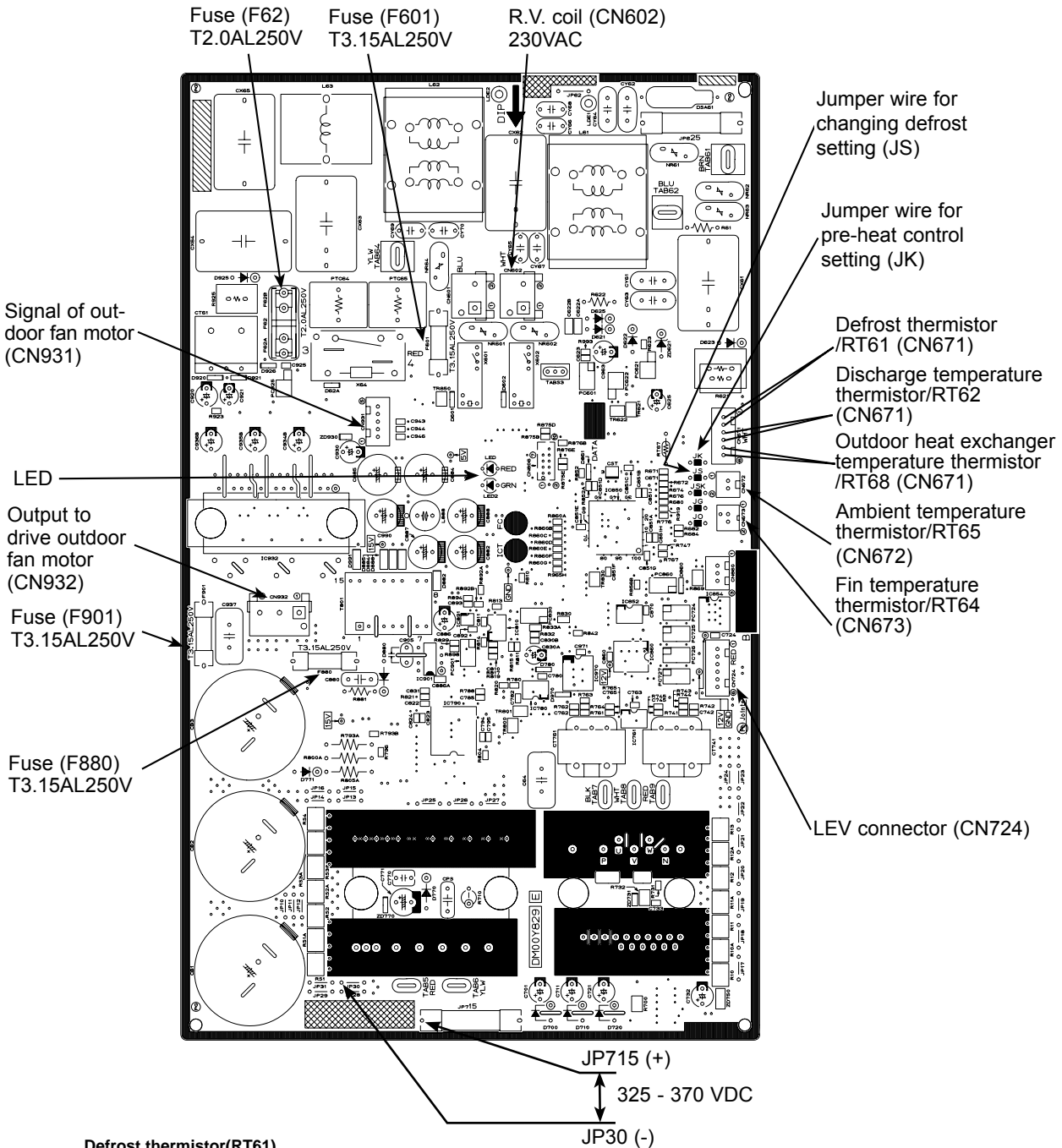

Defrost thermistor(RT61)  
Ambient temperature thermistor(RT65)  
Outdoor heat exchanger temperature thermistor(RT68)

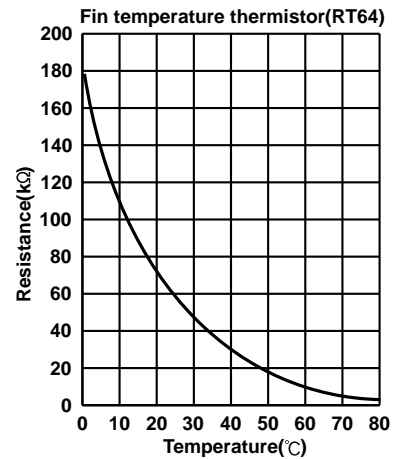
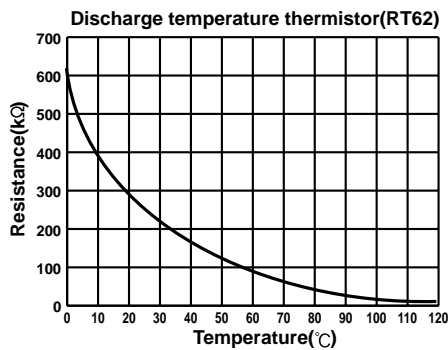
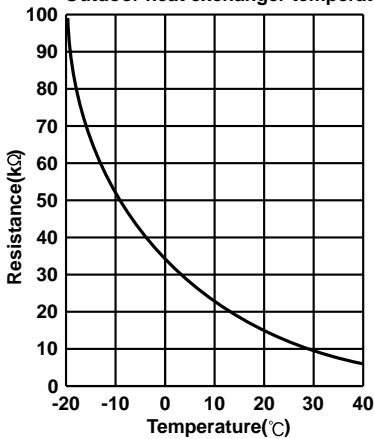

## &lt;"Terminal with locking mechanism" Detaching points&gt;

The terminal which has the locking mechanism can be detached as shown below.  
There are two types (refer to (1) and (2)) of the terminal with locking mechanism.  
The terminal without locking mechanism can be detached by pulling it out.  
Check the shape of the terminal before detaching.

(1) Slide the sleeve and check if there is a locking lever or not.

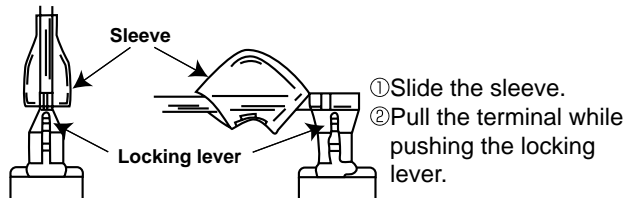

(2) The terminal with this connector has the locking mechanism.

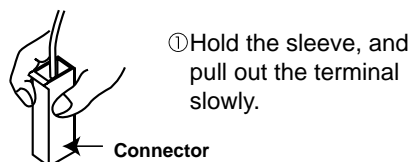

### 12-1. MUZ-GE25VA MUZ-GE25VAH MUZ-GE35VA MUZ-GE35VAH MUZ-GE42VA MUZ-GE42VAH

**NOTE:** Turn OFF power supply before disassembling.

OPERATING PROCEDURE	PHOTOS
<p><b>1. Removing the cabinet</b></p> <ol style="list-style-type: none"> <li>(1) Remove the screw fixing the service panel.</li> <li>(2) Pull down the service panel and remove it.</li> <li>(3) Disconnect the power supply and indoor/outdoor connecting wire.</li> <li>(4) Remove the screws fixing the top panel.</li> <li>(5) Remove the top panel.</li> <li>(6) Remove the screws fixing the cabinet.</li> <li>(7) Remove the cabinet.</li> <li>(8) Remove the screws fixing the back panel.</li> <li>(9) Remove the back panel.</li> </ol>	<p><b>Photo 1</b></p> <p><b>Photo 2</b></p>

## OPERATING PROCEDURE

### 2. Removing the inverter assembly, inverter P.C. board

- (1) Remove the cabinet and panels. (Refer to 1.)
- (2) Disconnect the lead wire to the reactor and the following connectors:  
<Inverter P.C. board>  
CN721 (R.V. coil)  
CN722 (Defrost heater)  
CN932 (Fan motor)  
CN641 (Defrost thermistor and discharge temperature thermistor)  
CN643 (Ambient temperature thermistor)  
CN644 (Outdoor heat exchanger temperature thermistor)  
CN724 (LEV)
- (3) Remove the compressor connector (CN61).
- (4) Remove the screws fixing the relay panel. (Photo 3)
- (5) Remove the inverter assembly. (Photo 4)
- (6) Remove the screw of the earth wire and screw of the T.B.support. (Photo 4)
- (7) Remove the relay panel from the inverter assembly.
- (8) Remove the inverter P.C. board from the relay panel.

### 3. Removing R.V. coil

- (1) Remove the cabinet and panels. (Refer to 1.)
- (2) Disconnect the following connectors:  
<Inverter P.C. board>  
CN721 (R.V. coil)
- (3) Remove the R.V. coil. (Photo 5)

### 4. Removing the discharge temperature thermistor, defrost thermistor, outdoor heat exchanger temperature thermistor and ambient temperature thermistor

- (1) Remove the cabinet and panels. (Refer to 1.)
- (2) Disconnect the lead wire to the reactor and the following connectors:  
<Inverter P.C. board>  
CN641 (Defrost thermistor and discharge temperature thermistor)  
CN643 (Ambient temperature thermistor)  
CN644 (Outdoor heat exchanger temperature thermistor)
- (3) Pull out the discharge temperature thermistor from its holder. (Photo 5)
- (4) Pull out the defrost thermistor from its holder. (Photo 6)
- (5) Pull out the outdoor heat exchanger temperature thermistor from its holder. (Photo 6)
- (6) Pull out the ambient temperature thermistor from its holder.

## PHOTOS

Photo 3

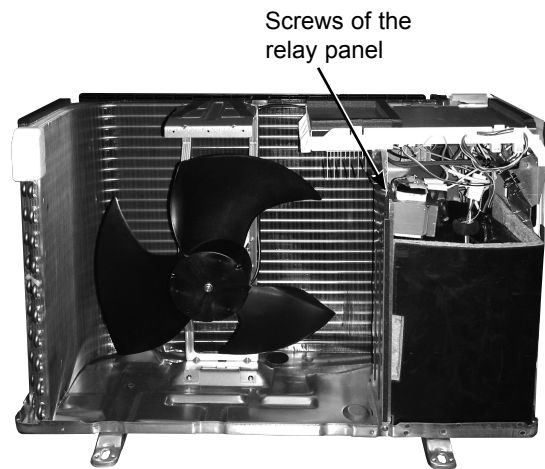

Photo 4 (Inverter assembly)

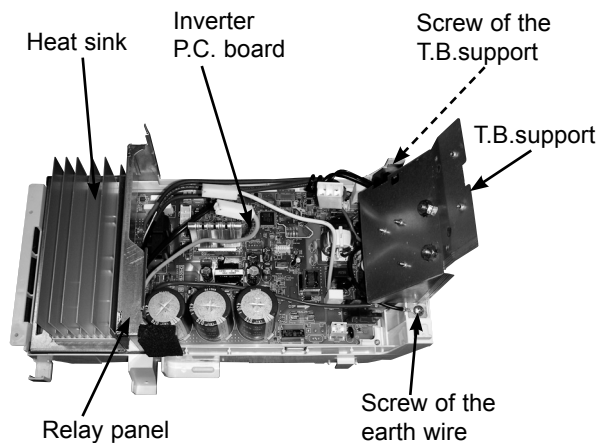

Photo 5



## OPERATING PROCEDURE

### 5. Removing outdoor fan motor

- (1) Remove the cabinet and panels. (Refer to 1.)
- (2) Disconnect the following connectors:  
<Inverter P.C. board>  
CN932 (Fan motor)
- (3) Remove the propeller nut. (Photo 7)
- (4) Remove the propeller. (Photo 7)
- (5) Remove the screws fixing the fan motor. (Photo 7)
- (6) Remove the fan motor.

### 6. Removing the compressor and 4-way valve

- (1) Remove the cabinet and panels. (Refer to 1.)
- (2) Remove the inverter assembly. (Refer to 2.)
- (3) Recover gas from the refrigerant circuit.  
**NOTE:** Recover gas from the pipes until the pressure gauge shows 0 kg/cm<sup>2</sup> (0 MPa).
- (4) Detach the welded part of the suction and the discharge pipe connected with compressor.
- (5) Remove the nuts of compressor legs.
- (6) Remove the compressor.
- (7) Detach the welded part of pipes connected with 4-way valve. (Photo 8)

## PHOTOS

Photo 6

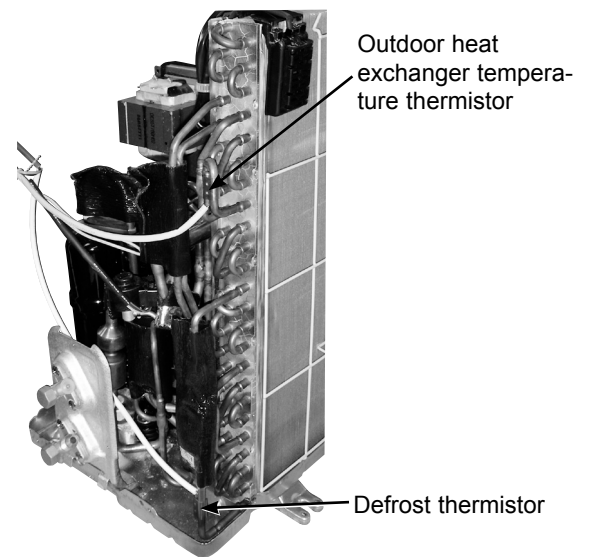

Photo 7

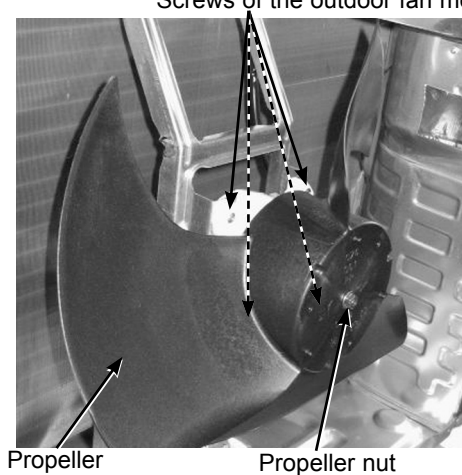
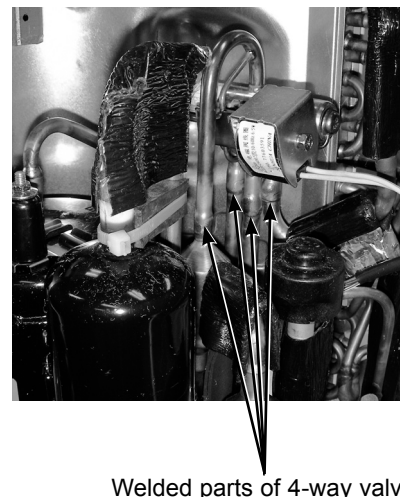
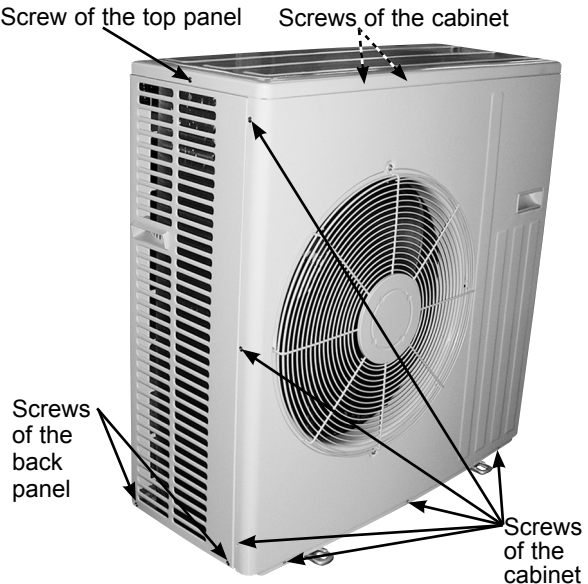
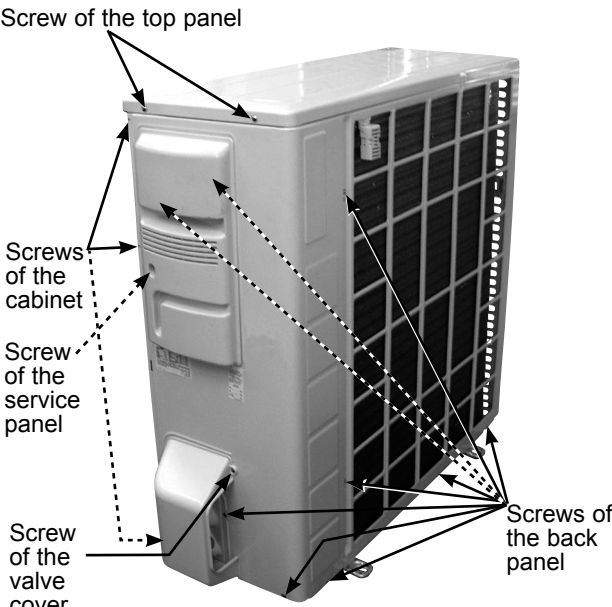

Photo 8



## 12-2. MUZ-GE50VA MUZ-GE50VAH

**NOTE:** Turn OFF power supply before disassembling.

OPERATING PROCEDURE	PHOTOS
<p><b>1. Removing the cabinet</b></p> <ol style="list-style-type: none"><li>(1) Remove the screws of the service panel.</li><li>(2) Remove the screws of the top panel.</li><li>(3) Remove the screw of the valve cover.</li><li>(4) Remove the service panel.</li><li>(5) Remove the top panel.</li><li>(6) Remove the valve cover.</li><li>(7) Disconnect the power supply and indoor/outdoor connecting wire.</li><li>(8) Remove the screws of the cabinet.</li><li>(9) Remove the cabinet.</li><li>(10) Remove the screws of the back panel.</li><li>(11) Remove the back panel.</li></ol>	<p><b>Photo 1</b></p>  <p>Screw of the top panel    Screws of the cabinet</p> <p>Screws of the back panel</p> <p>Screws of the cabinet</p> <p><b>Photo 2</b></p>  <p>Screw of the top panel</p> <p>Screws of the cabinet</p> <p>Screw of the service panel</p> <p>Screw of the valve cover</p> <p>Screws of the back panel</p>



## OPERATING PROCEDURE

### 2. Removing the inverter assembly, inverter P.C. board

- (1) Remove the cabinet and panels. (Refer to 1.)
- (2) Disconnect the lead wire to the reactor and the following connectors:  
<Inverter P.C. board>  
CN721 (R.V. coil)  
CN931, CN932 (Fan motor)  
CN641 (Defrost thermistor and discharge temperature thermistor)  
CN643 (Ambient temperature thermistor)  
CN644 (Outdoor heat exchanger temperature thermistor)  
CN724 (LEV)
- (3) Remove the compressor connector (CN61).
- (4) Remove the screws fixing the relay panel. (Photo 3)
- (5) Remove the inverter assembly. (Photo 4)
- (6) Remove the screw of the earth wire and screw of the T.B. support. (Photo 4)
- (7) Remove the screw of the PB fixture.
- (8) Remove the relay panel from the PB support.
- (9) Remove the inverter P.C. board from the inverter assembly.

### 3. Removing R.V. coil

- (1) Remove the cabinet and panels. (Refer to 1.)
- (2) Disconnect the following connectors:  
<Inverter P.C. board>  
CN721 (R.V. coil)
- (3) Remove the R.V. coil. (Photo 5)

## PHOTOS

Photo 3

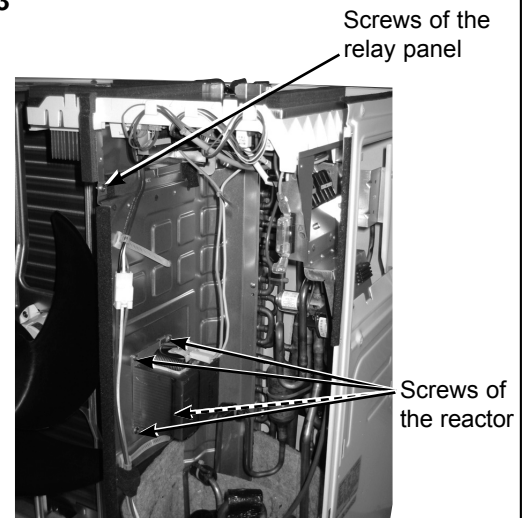

Photo 4 (Inverter assembly)

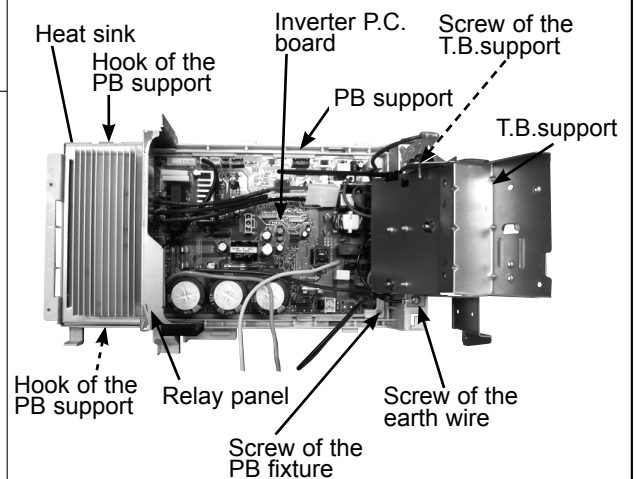
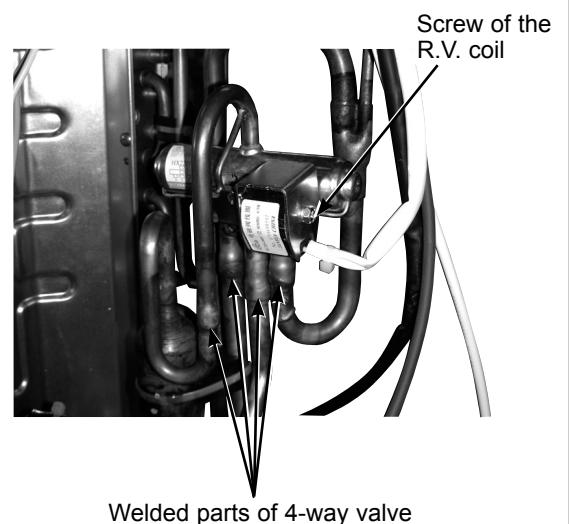

Photo5



## OPERATING PROCEDURE

### 4. Removing the discharge temperature thermistor, defrost thermistor, outdoor heat exchanger temperature thermistor and ambient temperature thermistor

- (1) Remove the cabinet and panels. (Refer to 1.)
- (2) Disconnect the lead wire to the reactor and the following connectors:  
<Inverter P.C. board>  
CN641 (Defrost thermistor and discharge temperature thermistor)  
CN643 (Ambient temperature thermistor)  
CN644 (Outdoor heat exchanger temperature thermistor)
- (3) Pull out the discharge temperature thermistor from its holder. (Photo 8)
- (4) Pull out the defrost thermistor from its holder. (Photo 6)
- (5) Pull out the outdoor heat exchanger temperature thermistor from its holder. (Photo 6)
- (6) Pull out the ambient temperature thermistor from its holder. (Photo 6)

### 5. Removing outdoor fan motor

- (1) Remove the top panel, cabinet and service panel. (Refer to 1.)
- (2) Disconnect the following connectors:  
<Inverter P.C. board>  
CN931 and CN932 (Fan motor)
- (3) Remove the propeller.
- (4) Remove the screws fixing the fan motor.
- (5) Remove the fan motor.

### 6. Removing the compressor and 4-way valve

- (1) Remove the top panel, cabinet and service panel. (Refer to 1.)
- (2) Remove the back panel. (Refer to 1.)
- (3) Remove the inverter assembly. (Refer to 2.)
- (4) Recover gas from the refrigerant circuit.  
**NOTE:** Recover gas from the pipes until the pressure gauge shows 0 kg/cm<sup>2</sup> (0 MPa).
- (5) Detach the welded part of the suction and the discharge pipe connected with compressor.
- (6) Remove the compressor nuts.
- (7) Remove the compressor.
- (8) Detach the welded part of 4-way valve and pipe. (Photo 5.)

## PHOTOS

Photo 6

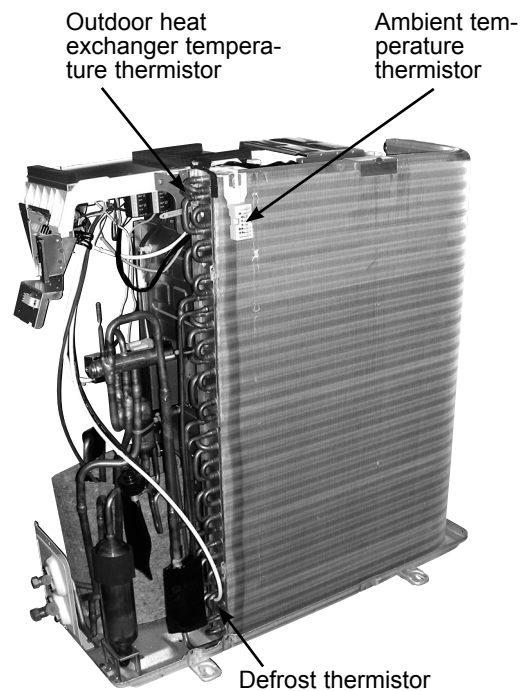

Photo 7

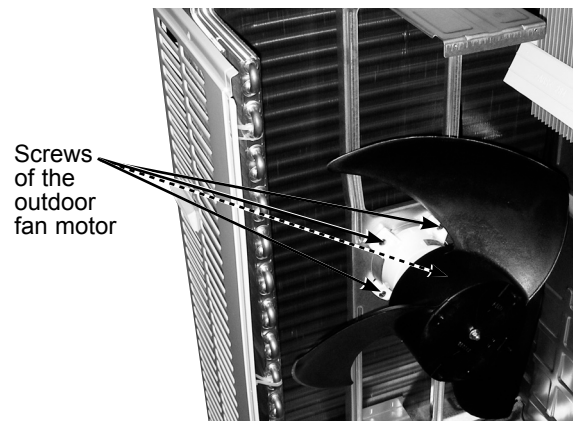
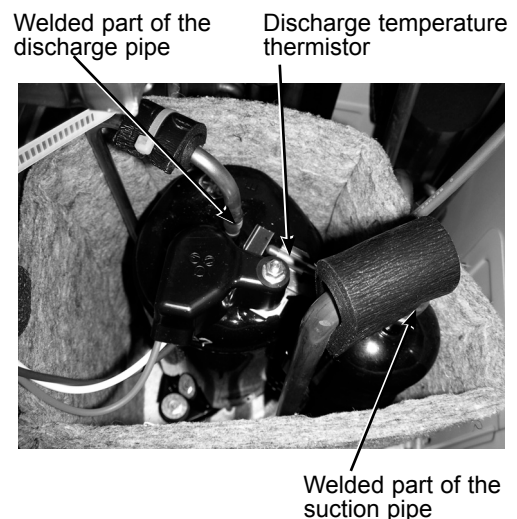
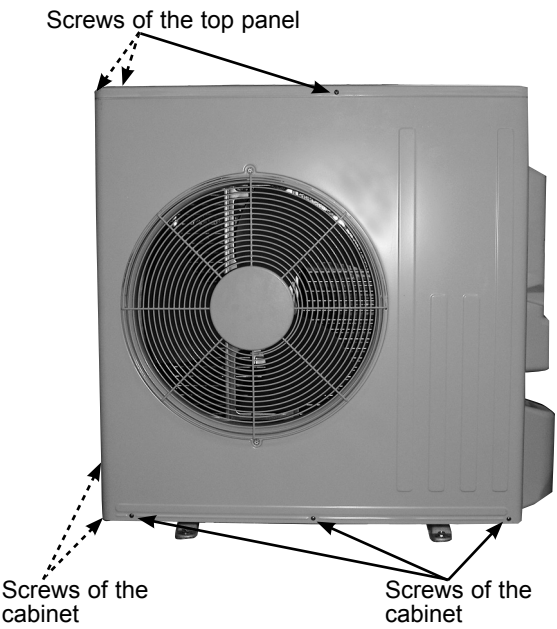
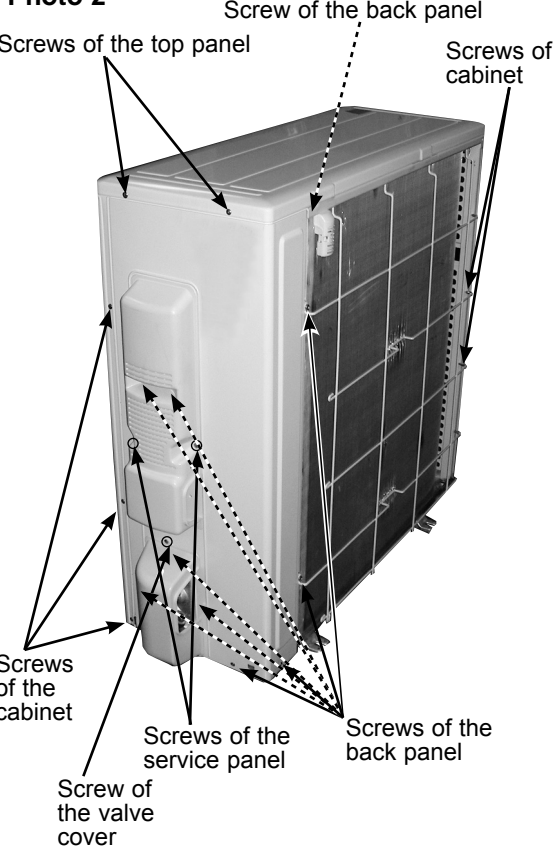

Photo 8



## 12-3. MUZ-GE60VA MUZ-GE71VA

**NOTE:** Turn OFF power supply before disassembling.

OPERATING PROCEDURE	PHOTOS
<p><b>1. Removing the cabinet</b></p> <ol style="list-style-type: none"><li>(1) Remove the screws of the service panel.</li><li>(2) Remove the screws of the top panel.</li><li>(3) Remove the screw of the valve cover.</li><li>(4) Remove the service panel.</li><li>(5) Remove the top panel.</li><li>(6) Remove the valve cover.</li><li>(7) Disconnect the power supply and indoor/outdoor connecting wire.</li><li>(8) Remove the screws of the cabinet.</li><li>(9) Remove the cabinet.</li><li>(10) Remove the screws of the back panel.</li><li>(11) Remove the back panel.</li></ol>	<p><b>Photo 1</b></p>  <p>Screws of the top panel</p> <p>Screws of the cabinet</p> <p>Screws of the cabinet</p> <p><b>Photo 2</b></p>  <p>Screw of the back panel</p> <p>Screws of the top panel</p> <p>Screws of the cabinet</p> <p>Screws of the cabinet</p> <p>Screws of the service panel</p> <p>Screws of the back panel</p> <p>Screw of the valve cover</p>

## OPERATING PROCEDURE

### 2. Removing the inverter assembly, inverter P.C. board

- (1) Remove the cabinet and panels. (Refer to 1.)
- (2) Disconnect the lead wire to the reactor and the following connectors:
  - <Inverter P.C. board>
  - CN602 (R.V. coil)
  - CN931, CN932 (Fan motor)
  - CN671 (Defrost thermistor, discharge temperature thermistor and outdoor heat exchanger temperature thermistor)
  - CN672 (Ambient temperature thermistor)
  - CN724 (LEV)
- (3) Remove the compressor connector.
- (4) Remove the screws fixing the relay panel.
- (5) Remove the relay panel.
- (6) Remove the earth wires and the lead wires of the inverter P.C. board.
- (7) Remove the screw of the PB support.
- (8) Remove the inverter P.C. board from the relay panel.

### 3. Removing R.V. coil

- (1) Remove the cabinet and panels. (Refer to 1.)
- (2) Disconnect the following connector:
  - <Inverter P.C. board>
  - CN602 (R.V. coil)
- (3) Remove the R.V. coil.

## PHOTOS

Photo 3

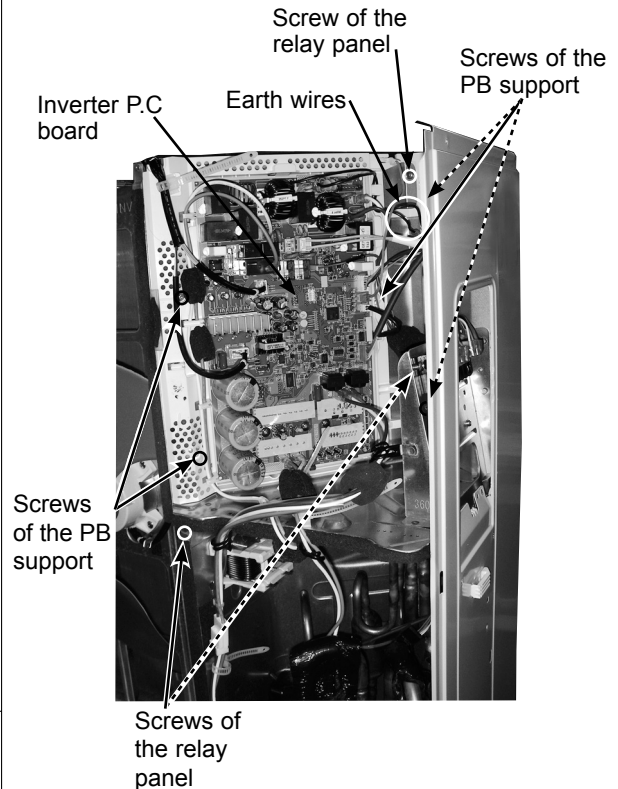
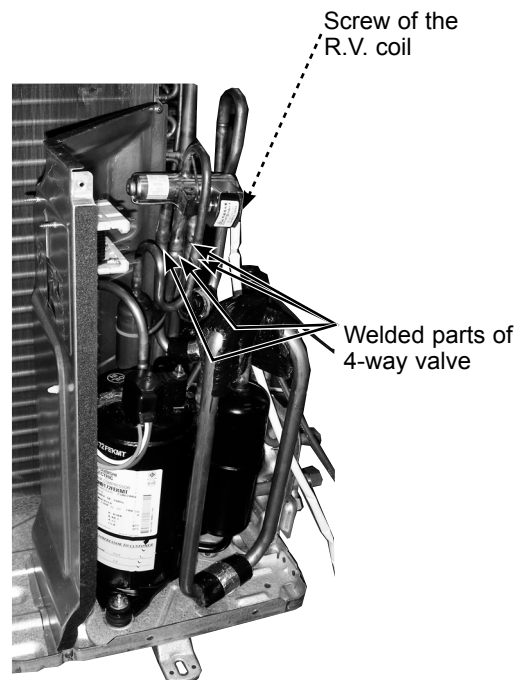

Photo 4



## OPERATING PROCEDURE

### 4. Removing the discharge temperature thermistor, defrost thermistor, outdoor heat exchanger temperature thermistor and ambient temperature thermistor

- (1) Remove the cabinet and panels. (Refer to 1.)
- (2) Disconnect the lead wire to the reactor and the following connectors:  
<Inverter P.C. board>  
CN671 (Defrost thermistor, discharge temperature thermistor and outdoor heat exchanger temperature thermistor)  
CN672 (Ambient temperature thermistor)
- (3) Pull out the discharge temperature thermistor from its holder. (Photo 7)
- (4) Pull out the defrost thermistor from its holder.
- (5) Pull out the outdoor heat exchanger temperature thermistor from its holder.
- (6) Pull out the ambient temperature thermistor from its holder.

### 5. Removing outdoor fan motor

- (1) Remove the top panel, cabinet and service panel. (Refer to 1.)
- (2) Disconnect the following connectors:  
<Inverter P.C. board>  
CN931 and CN932 (Fan motor)
- (3) Remove the propeller.
- (4) Remove the screws fixing the fan motor.
- (5) Remove the fan motor.

### 6. Removing the compressor and 4-way valve

- (1) Remove the top panel, cabinet and service panel. (Refer to 1.)
- (2) Remove the back panel. (Refer to 1.)
- (3) Remove the inverter assembly. (Refer to 2.)
- (4) Recover gas from the refrigerant circuit.  
**NOTE:** Recover gas from the pipes until the pressure gauge shows 0 kg/cm<sup>2</sup> (0 MPa).
- (5) Detach the welded part of the suction and the discharge pipe connected with compressor.
- (6) Remove the compressor nuts.
- (7) Remove the compressor.
- (8) Detach the welded part of 4-way valve and pipe. (Photo 4)

## PHOTOS

Photo 5

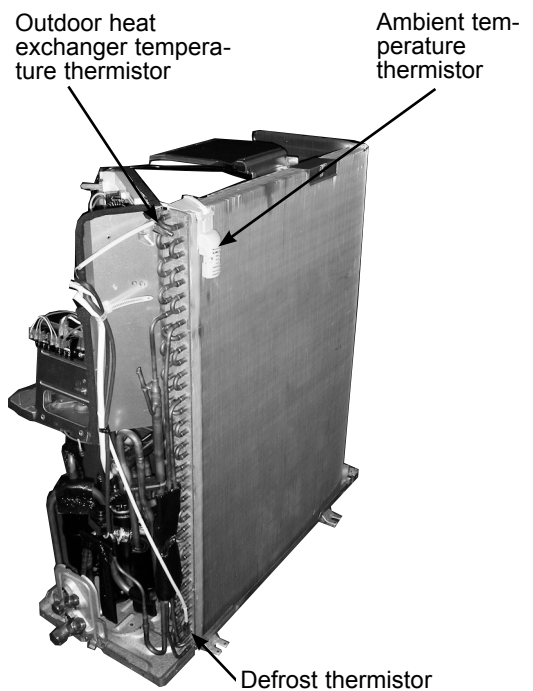

Photo 6

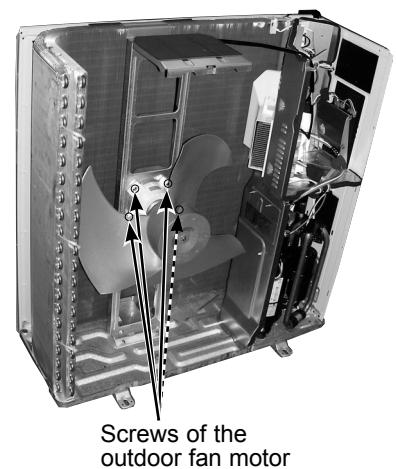
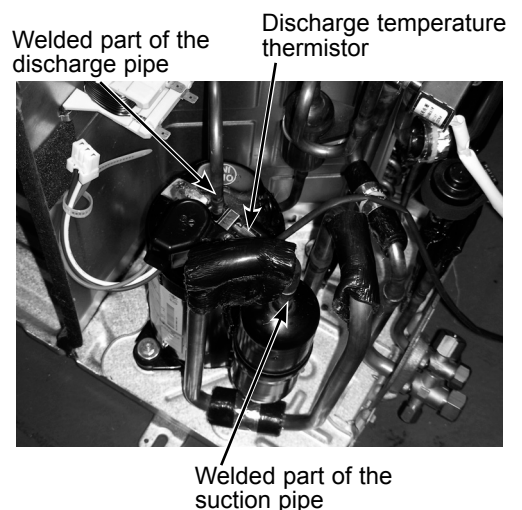

Photo 7





HEAD OFFICE: TOKYO BLDG., 2-7-3, MARUNOUCHI, CHIYODA-KU, TOKYO 100-8310, JAPAN

© Copyright 2008 MITSUBISHI ELECTRIC CO.,LTD  
Distributed in Jun. 2010. No. OBH516 REVISED EDITION-C 5  
Distributed in Oct. 2009. No. OBH516 REVISED EDITION-B 5  
Distributed in Dec. 2008. No. OBH516 REVISED EDITION-A 5  
Distributed in Aug. 2008. No. OBH516 6  
Made in Japan

New publication, effective Jun. 2010  
Specifications subject to change without notice.