

**Revision A:**

• Another type of the electronic control P.C. board (TYPE 2) has been added to the original one (TYPE 1). They are both compatible with MS-GD80VB-**E1**.

Please void OBH511.

# INDOOR UNIT

# SERVICE MANUAL

**No. OBH511**  
**REVISED EDITION-A**

Wireless type  
Model  
**MS-GD80VB** - **E1**

**Outdoor unit service manual**  
**MU-GD•VB Series (OBH512)**

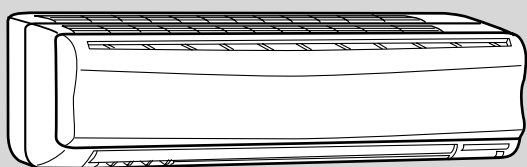

## CONTENTS

1. TECHNICAL CHANGES .....	2
2. PART NAMES AND FUNCTIONS .....	2
3. SPECIFICATION .....	3
4. NOISE CRITERIA CURVES .....	3
5. OUTLINES AND DIMENSIONS .....	4
6. WIRING DIAGRAM .....	4
7. REFRIGERANT SYSTEM DIAGRAM .....	5
8. SERVICE FUNCTIONS .....	6
9. MICROPROCESSOR CONTROL .....	8
10. TROUBLESHOOTING .....	14
11. DISASSEMBLY INSTRUCTIONS .....	23

**PARTS CATALOG (OBB511)**

**NOTE:**  
RoHS compliant products have <G> mark on the spec name plate.



# Use the specified refrigerant only

## Never use any refrigerant other than that specified.

Doing so may cause a burst, an explosion, or fire when the unit is being used, serviced, or disposed of.

Correct refrigerant is specified in the manuals and on the spec labels provided with our products.

We will not be held responsible for mechanical failure, system malfunction, unit breakdown or accidents caused by failure to follow the instructions.

### Revision A:

- Another type of the electronic control P.C. board (TYPE 2) has been added to the original one (TYPE 1). They are both compatible with MS-GD80VB-**E1**.

## 1 TECHNICAL CHANGES

### MS-GD80VB -**E1**

1. New model

## 2 PART NAMES AND FUNCTIONS

### MS-GD80VB

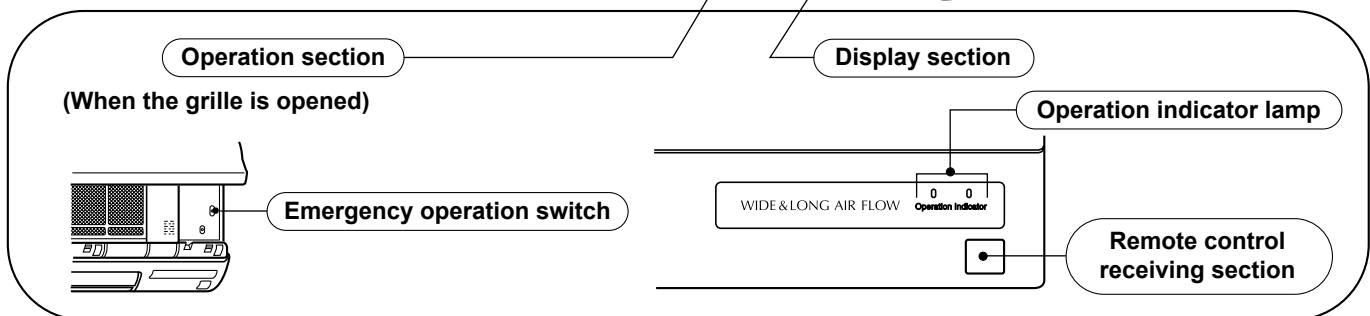
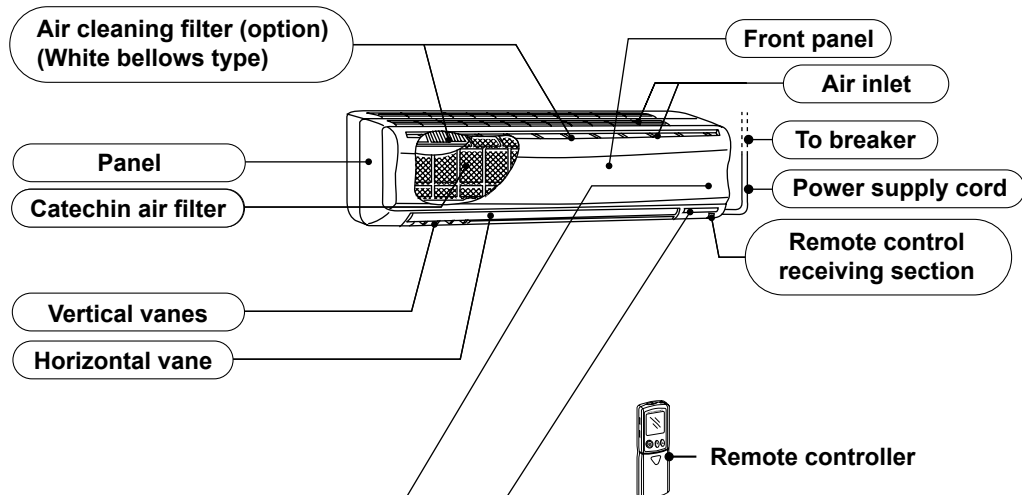

### ACCESSORIES

		MS-GD80VB
①	Installation plate	1
②	Installation plate fixing screw 4 × 25 mm	7
③	Remote controller holder	1
④	Fixing screw for ③ × 3.5 × 1.6 mm (Black)	2
⑤	Battery (AAA) for remote controller	2
⑥	Wireless remote controller	1
⑦	Felt tape (Used for left or left-rear piping)	1

### 3

## SPECIFICATION

Indoor model		<b>MS-GD80VB</b>	
Function		Cooling	
Power supply		Single phase 230 V, 50 Hz	
Electrical data	Breaker capacity	A	10
	Running current	A	0.34
	Power input	W	69
	Power factor	%	88
Fan motor	Model	RC4V40-AA	
	Fan motor current	A	0.34
Dimensions W × H × D		mm	1,100 × 325 × 258
Weight		kg	16
Special remarks	Air direction		5
	Air flow (High/Med./Low)	m <sup>3</sup> /h	954/822/684
	Sound level (High/Med./Low)	dB	47/42/37
	Fan speed (High/Med./Low)	rpm	1,280/1,130/970
	Fan speed regulator		3
Remote controller model		KM04B	

**NOTE:** Test conditions are based on ISO 5151.

Cooling: Indoor Dry-bulb temperature 27°C Wet-bulb temperature 19°C  
 Outdoor Dry-bulb temperature 35°C Wet-bulb temperature 24°C  
 Indoor-Outdoor piping length: 5 m

### 4

## NOISE CRITERIA CURVES

### MS-GD80VB

FAN SPEED	SPL(dB(A))	LINE
High	47	●—●

Test conditions,  
 Cooling : Dry-bulb temperature 27°C Wet-bulb temperature 19°C

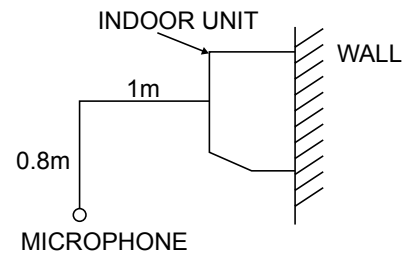
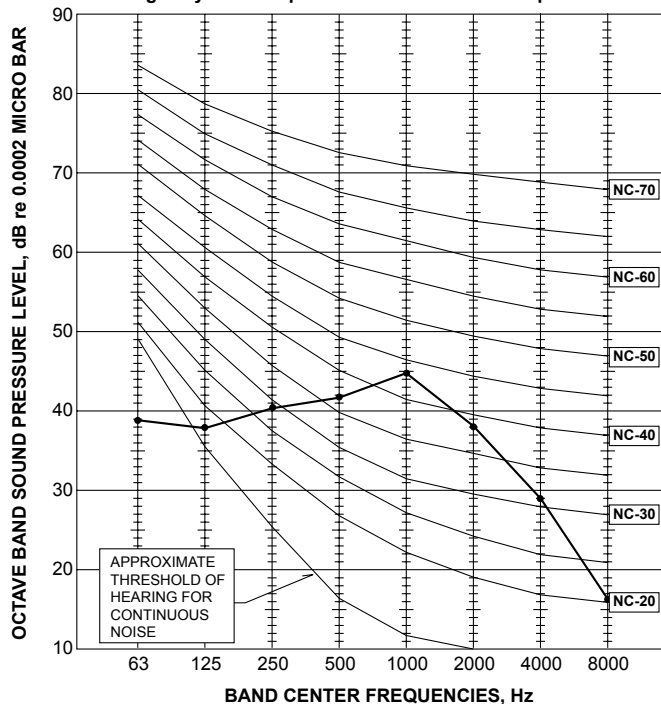

# 5

# OUTLINES AND DIMENSIONS

## MS-GD80VB

Unit: mm

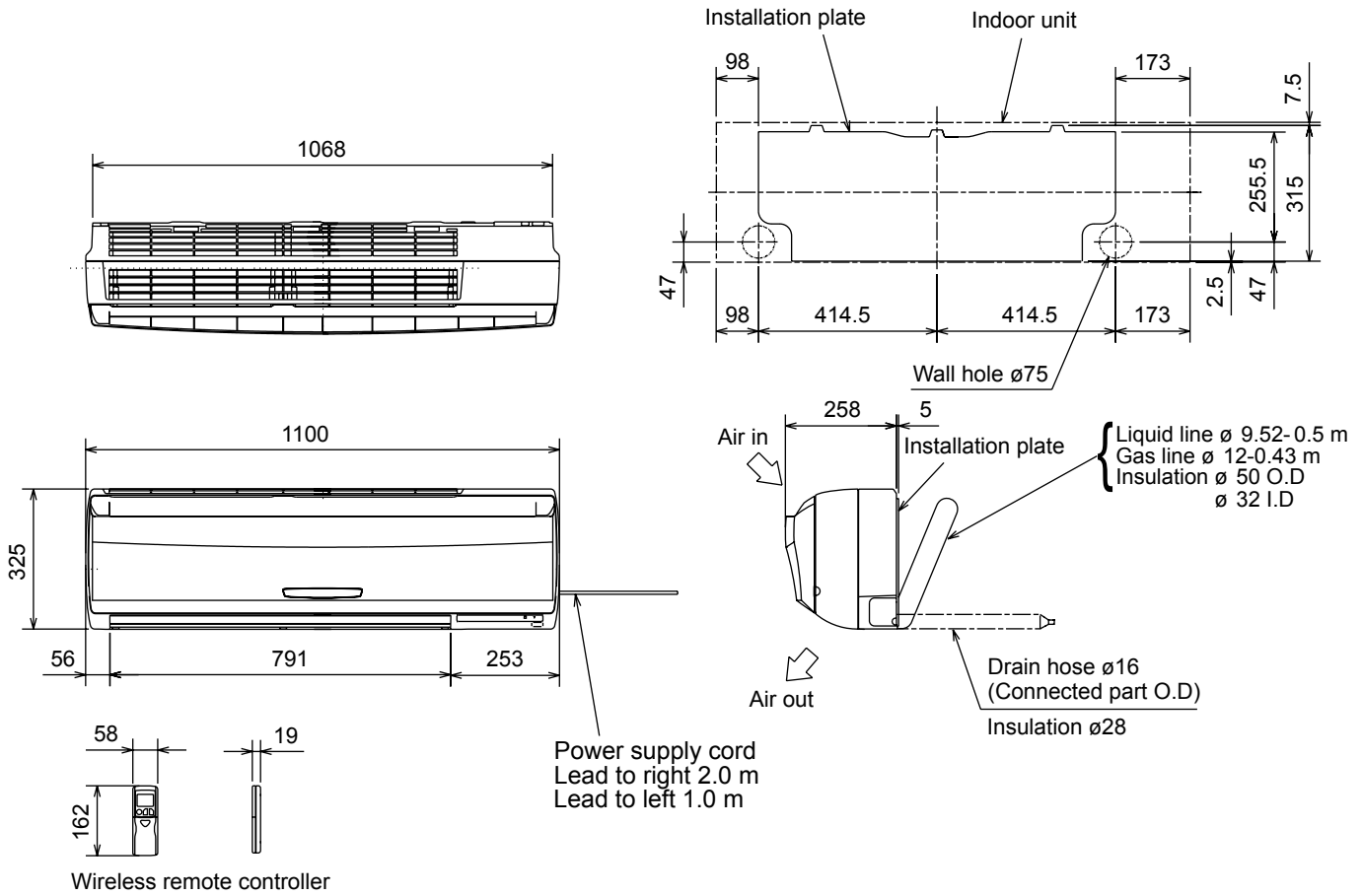

# 6

# WIRING DIAGRAM

## MS-GD80VB

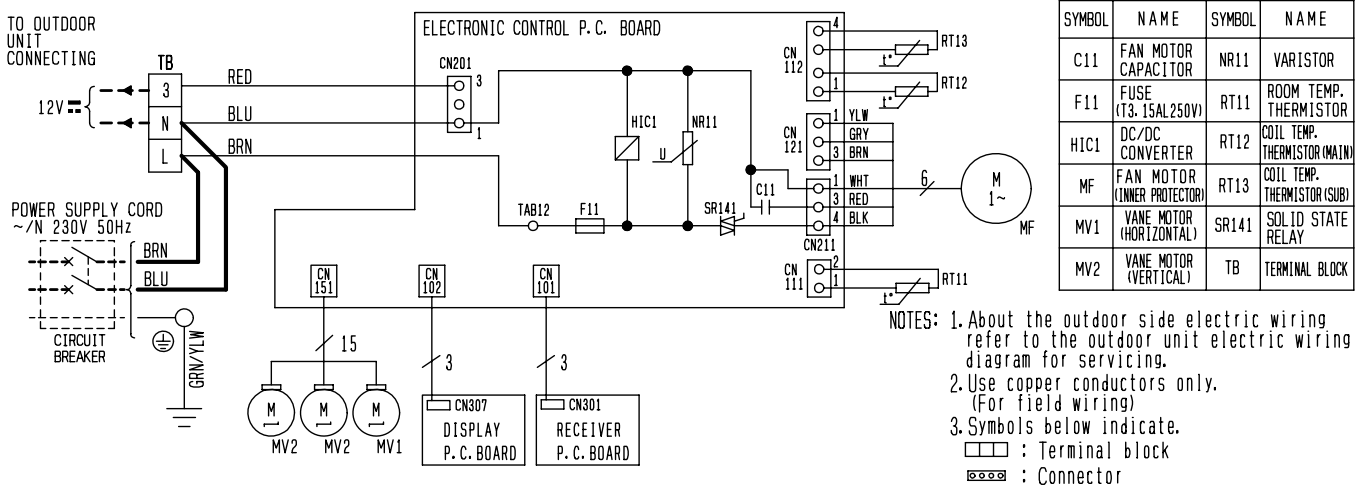

MS-GD80VB

Unit: mm

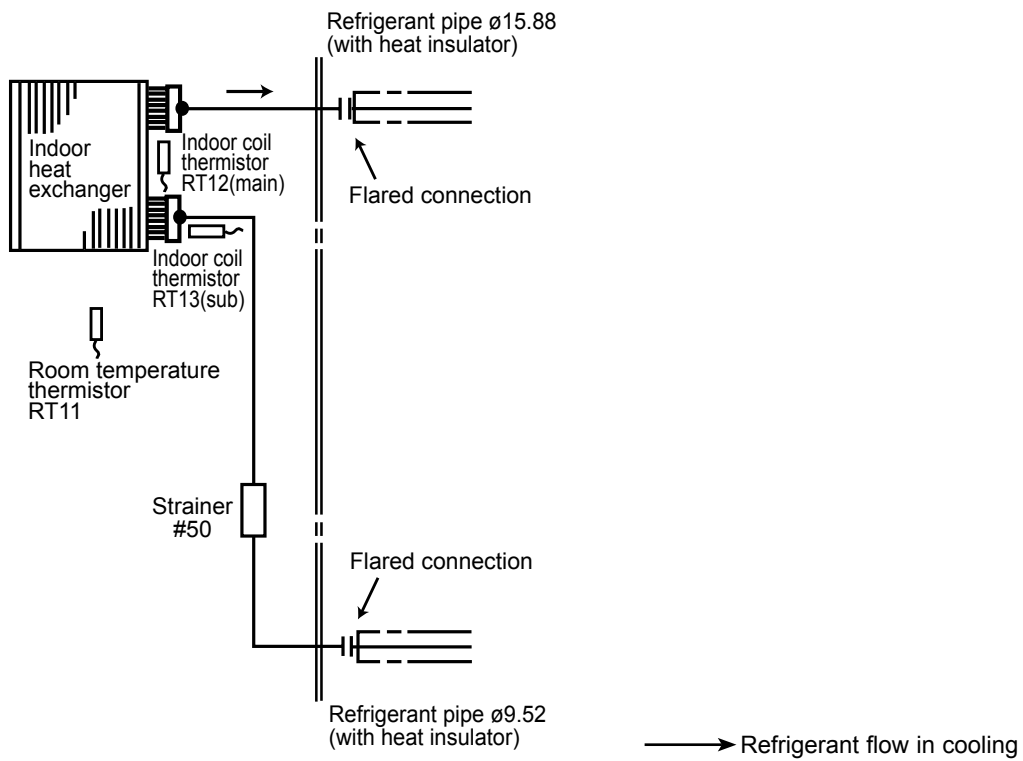

## MS-GD80VB

### 8-1. TIMER SHORT MODE

For service, set time can be shortened by short circuit of JPG and JPS on the electronic control P.C. board.  
(Refer to 10-6.)

The time will be shortened as follows.

Set time: 1 minute → 1-second

Set time: 3 minute → 3-second (It takes 3 minutes for the compressor to start operation. However, the starting time is shortened by short circuit of JPG and JPS.)

### 8-2. P.C. BOARD MODIFICATION FOR INDIVIDUAL OPERATION

A maximum of 4 indoor units with wireless remote controllers can be used in a room.

In this case, to operate each indoor unit individually by each remote controller, P.C. boards of remote controller must be modified according to the number of the indoor unit.

#### How to modify the remote controller P.C. board

Remove batteries before modification.

The board has a print as shown below:

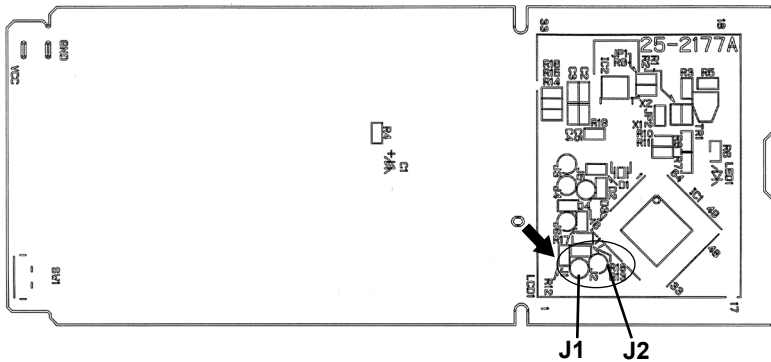

**NOTE:** For modification, take out the batteries and press the OPERATE/ STOP (ON/OFF) button 2 or 3 times at first. After modification, put back the batteries then press the RESET button.

The P.C. board has the print "J1" and "J2". Solder "J1" and "J2" according to the number of indoor unit as shown in Table 1. After modification, press the RESET button.

**Table 1**

	1 unit operation	2 units operation	3 units operation	4 units operation
No. 1 unit	No modification	Same as at left	Same as at left	Same as at left
No. 2 unit	—	Solder J1	Same as at left	Same as at left
No. 3 unit	—	—	Solder J2	Same as at left
No. 4 unit	—	—	—	Solder both J1 and J2

#### How to set the remote controller exclusively for particular indoor unit

After you turn the breaker ON, the first remote controller that sends the signal to the indoor unit will be regarded as the remote controller for the indoor unit.

The indoor unit will only accept the signal from the remote controller that has been assigned to the indoor unit once they are set. The setting will be cancelled if the breaker has turned OFF, or the power supply has shut down.

Please conduct the above setting once again after the power has restored.

### 8-3. AUTO RESTART FUNCTION

When the indoor unit is controlled with the remote controller, the operation mode, set temperature, and the fan speed are memorized by the indoor electronic control P.C. board. The "AUTO RESTART FUNCTION" automatically starts operation in the same mode just before the shutoff of the main power. However if the unit is operated in "I FEEL CONTROL" mode before power failure, the operation is not memorized. In "I FEEL CONTROL" mode, the operation is decided by the initial room temperature.

#### Operation

- ① If the main power has been cut, the operation settings remain.
- ② After the power is restored, the unit restarts automatically according to the memory. (However, it takes at least 3 minutes for the compressor to start running.)

#### How to disable "AUTO RESTART FUNCTION"

- ① Turn OFF the main power for the unit.
- ② Solder jumper wire to JR07 on the indoor electronic control P.C. board. (Refer to 10-6.)

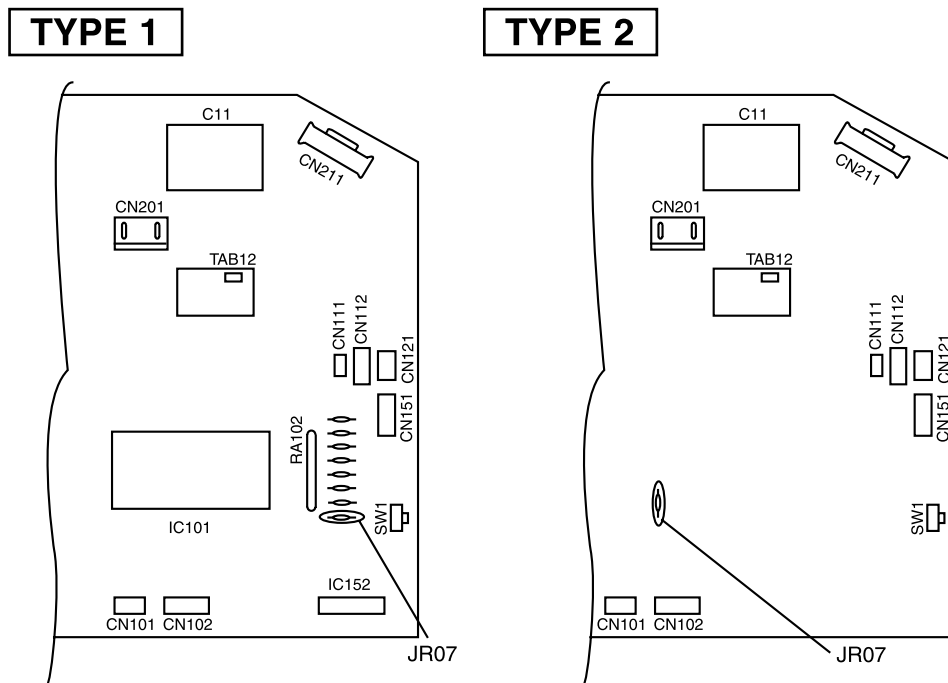

- NOTE:**
- The operation settings are memorized when 10 seconds have passed after the remote controller was operated with the remote controller.
  - If main power is turned OFF or a power failure occurs while AUTO START/STOP timer is active, the timer setting is cancelled.
  - If the unit has been OFF with the remote controller before power failure, the auto restart function does not work as the power button of the remote controller is OFF.
  - To prevent breaker OFF due to the rush of starting current, systematize other home appliances not to turn ON at the same time.
  - When some air conditioners are connected to the same supply system, if they are operated before power failure, the starting current of all the compressors may flow simultaneously at restart. Therefore, the special counter-measures are required to prevent the main voltage-drop or the rush of the starting current by adding to the system that allows the units to start one by one.

## MS-GD80VB

### WIRELESS REMOTE CONTROLLER

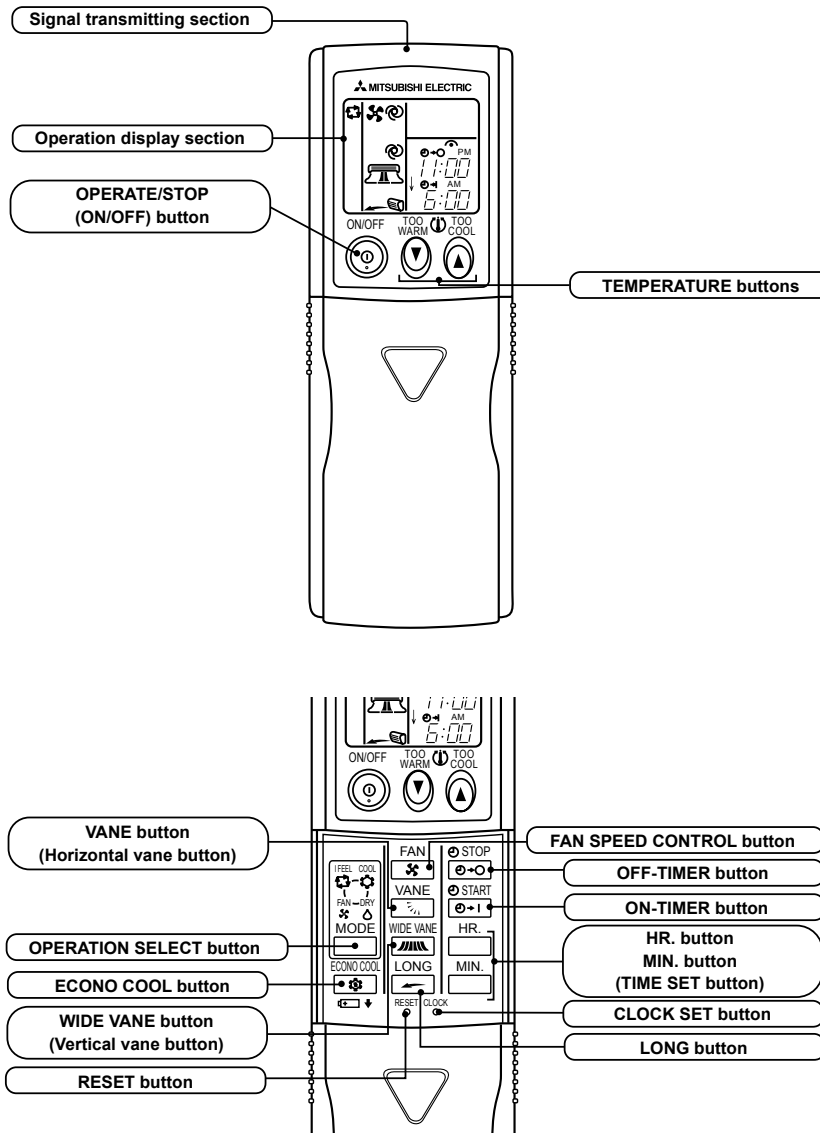

**NOTE:**

- The last setting will be stored after the unit is turned OFF with the remote controller.
- Indoor unit receives the signal of the remote controller with beeps.

### INDOOR UNIT DISPLAY SECTION

#### OPERATION INDICATOR lamp

The OPERATION INDICATOR at the right side of the indoor unit indicates the operation state.

• The following indication applies regardless of shape of the indicator.

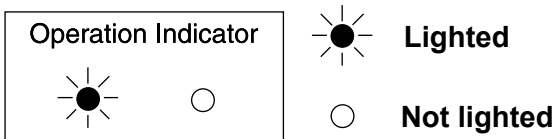

Indication	Operation state	Difference between target temperature and room temperature
	This shows that the air conditioner is operating to reach the target temperature. Please wait until the target temperature is obtained.	Approximate 2 °C or more
	This shows that the room temperature is approaching the target temperature.	Approximate 2 °C or less



## 9-1. COOL ( ❄ ) OPERATION

- (1) Press OPERATE/STOP (ON/OFF) button.  
OPERATION INDICATOR lamp of the indoor unit turns on with a beep tone.
- (2) Select COOL mode with OPERATION SELECT button.
- (3) Press TEMPERATURE buttons.  
(TOO WARM or TOO COOL button) to select the desired temperature.  
The setting range is 16 ~ 31°C  
※ Indoor fan continues to operate regardless of thermostat's OFF-ON at set speed.

### 1. Coil frost prevention

When the temperature of indoor heat exchanger becomes too low, the coil frost prevention mode works.  
The indoor fan operates at the set speed and the compressor stops. This mode continues until the temperature of indoor heat exchanger rises.

### 2. Discharge temperature protection

The compressor is controlled by the temperature of discharge temperature thermistor RT62 for excess rise protection of compressor discharge pressure.

## 9-2. DRY ( ☀ ) OPERATION

- (1) Press OPERATE/STOP (ON/OFF) button.  
OPERATION INDICATOR lamp of the indoor unit turns ON with a beep tone.
- (2) Select DRY mode with OPERATION SELECT button.
- (3) The set temperature is determined from the initial room temperature.
- (4) DRY operation will not function when the room temperature is 13°C or below.

### 1. Indoor fan speed control

Indoor fan operates at the set speed by FAN SPEED CONTROL button.  
However, in AUTO fan operation, fan speed becomes Low.

### 2. The operation of the compressor and indoor/outdoor fan

Compressor operates by room temperature control and time control.  
Set temperature is controlled to fall 2°C from initial room temperature.  
Indoor fan and outdoor fan operate in the same cycle as the compressor.

### 3. Coil frost prevention

- The operation is as same as coil frost prevention during COOL mode.
- Indoor fan operates at the set speed and the compressor stops for 5 minutes, because protection (Coil frost prevention) has the priority.  
However, when coil frost prevention works while the compressor is not operating, it's speed becomes Low.

## 9-3. FAN ( 🌀 ) OPERATION

- (1) Press OPERATE/STOP (ON/OFF) button.  
OPERATION INDICATOR lamp of the indoor unit turns ON with a beep tone.
- (2) Select FAN mode with OPERATION SELECT button.
- (3) Select the desired fan speed. When AUTO, it becomes Low.  
Only indoor fan operates. Outdoor unit dose not operate.

## 9-4. "I FEEL CONTROL" ( 🏠 ) OPERATION

- (1) Press OPERATE/STOP (ON/OFF) button on the remote controller. OPERATION INDICATOR lamp of the indoor unit turns ON with a beep tone.
- (2) Select "I FEEL CONTROL" mode with OPERATION SELECT button.
- (3) The operation mode is determined by the room temperature at start-up of the operation.

Initial room temperature	Mode
25°C or more	COOL mode of "I FEEL CONTROL"
more than 13°C, less than 25°C	DRY mode of "I FEEL CONTROL"

- Once the mode is fixed, the mode dose not change by room temperature afterwards.
- Under the ON-TIMER ( ⌚ → | ) operation, mode is determined as follows.

When the system is stopped on the remote controller, and restarted within 2 hours in " I FEEL CONTROL" ( 🏠 ) mode, the system operates in previous mode automatically regardless of the room temperature.



**Operation timer chart**

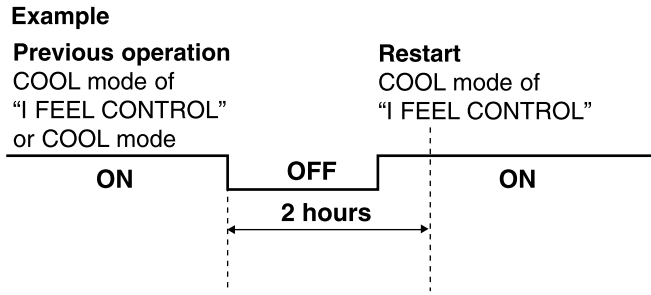

When the system is restarted after 2 hours and more, the operation mode is determined by the room temperature at start-up of the operation.

**Operation timer chart**

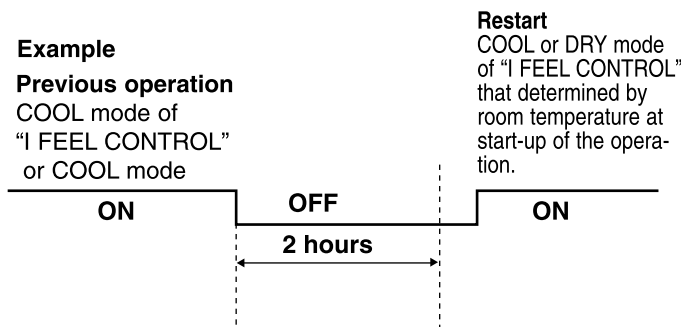

(4) The initial set temperature is decided by the initial room temperature.

Model	Initial room temperature	Initial set temperature	
COOL mode of "I FEEL CONTROL"	26°C or more	24°C	*1
	25°C to 26°C	Initial room temperature minus 2°C	
DRY mode of "I FEEL CONTROL"	more than 13°C, less than 25°C	Initial room temperature minus 2°C	

\*1 When the system is restarted with the remote controller, the system operates with the previous set temperature regardless of room temperature at restart. The set temperature is calculated by the previous set temperature.

(5) TEMPERATURE buttons

In "I FEEL CONTROL" (□) mode, set temperature is decided by the microprocessor based on the room temperature. In addition, set temperature can be controlled by TOO WARM or TOO COOL buttons when you feel too cool or too warm.

Each time the TOO WARM or TOO COOL button is pressed, the indoor unit receives the signal and emits a beep tone.

• Fuzzy control

When the TOO COOL or TOO WARM button is pressed, the microprocessor changes the set temperature, considering the room temperature, the frequency of pressing TOO COOL or TOO WARM button and the user's preference to heat or cool. So this is called "Fuzzy control", and works only in "I FEEL CONTROL" mode.

In DRY mode of "I FEEL CONTROL", the set temperature doesn't change.



**9-5. AUTO VANE OPERATION**

**1. Horizontal vane**

(1) Vane motor drive

These models are equipped with a stepping motor for the horizontal vane. The rotating direction, speed, and angle of the motor are controlled by pulse signals (approximate 12 V) transmitted from indoor microprocessor.

(2) The horizontal vane angle and mode change as follows by pressing the VANE button.

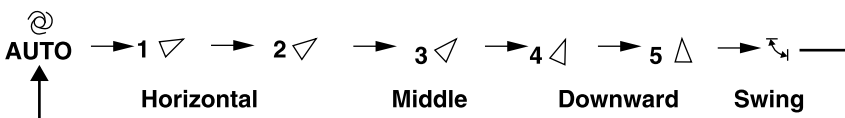

(3) Positioning

To confirm the standard position, the vane moves until it touches the vane stopper. Then the vane is set to the desired angle.

Confirming of standard position is performed in the following case:

- (a) When the power supply turns ON.
- (b) When the operation starts or finishes (including timer operation).
- (c) When the test run starts.
- (d) When the vane control is changed AUTO to MANUAL (except SWING).
- (d) When the SWING is finished (including ECONO COOL).

(4) VANE AUTO ( @ ) mode

In VANE AUTO mode, the microprocessor automatically determines the horizontal vane angle and operation to make the optimum room-temperature distribution.

① In COOL and DRY operation

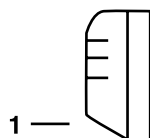

Vane angle is fixed to Angle 1.

② In FAN operation

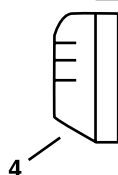

Vane angle is fixed to Angle 4.

(5) STOP (operation OFF) and ON-TIMER standby

When the following cases occur, the horizontal vane returns to the closed position.

- (a) When OPERATE/STOP (ON/OFF) button is pressed (POWER OFF).
- (b) When the operation is stopped by the emergency operation.
- (c) When ON-TIMER is on standby.

(6) Dew prevention

During COOL or DRY operation at Vane Angle 4 or 5 when the compressor cumulative operation time of compressor exceeds 1 hour, the vane angle automatically changes to Angle 1 for dew prevention.

(7) SWING ( ㄟ ) mode

By selecting SWING mode with VANE button, the horizontal vane swings vertically. The remote controller displays " ㄟ ". SWING mode is cancelled when VANE button is pressed once again.

(8) ECONO COOL ( ㄟ ) operation (ECONOMical operation)

When ECONO COOL button is pressed in COOL mode, set temperature is automatically set 2 °C higher.

Also the horizontal vane swings in various cycle.

SWING operation makes you feel cooler than set temperature. So, even though the set temperature is higher, the air conditioner can keep comfort. As a result, energy can be saved.

To cancel this operation, select a different mode or press one of the following buttons in ECONO COOL operation: ECONO COOL, VANE or LONG button.

(9) LONG ( ㄟ ) mode

By pressing LONG button indoor fan speed becomes faster than setting fan speed on the remote controller, and the horizontal vane moves to the position for LONG mode. The remote controller displays " ㄟ ".

To cancel this operation, press one of the following buttons:

ECONO COOL button in COOL mode, VANE or LONG button.

• In the following example, the vertical vane is set to ㄟ (front).

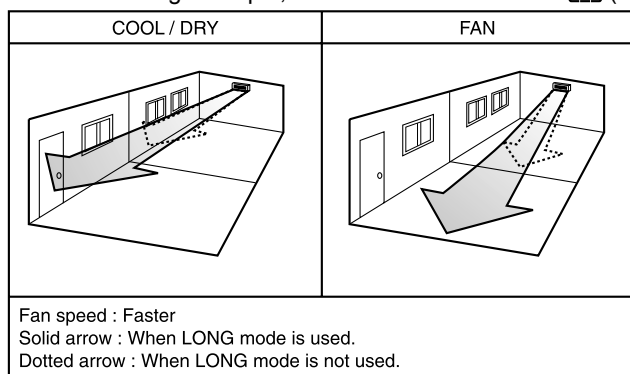

## 2. Vertical vane

### (1) Vane motor drive

These models are equipped with a stepping motor for the vertical vane. The rotating direction, speed, and angle of the motor are controlled by pulse signals (approximate 12 V) transmitted from microprocessor.

### (2) The vertical vane angle and mode change as follows by pressing WIDE VANE button.

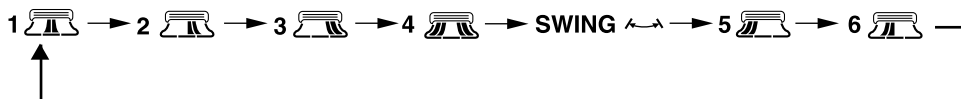

### (3) Positioning

To confirm the standard position, the vane moves until it touches the vane stopper. Then the vane is set to the desired angle.

Confirming of standard position is performed in the following case:

- When OPERATE/STOP (ON/OFF) button is pressed (POWER ON/OFF).
- When SWING is started or finished.
- When the power supply turns ON.

### (4) SWING (↔) mode

By selecting SWING mode with WIDE VANE button, the vertical vane swings horizontally. The remote controller displays "↔". The vane moves right and left in the width of Angle 4 repeatedly.

### (5) WIDE (🌀) mode

By selecting WIDE mode with WIDE VANE button, indoor fan speed becomes faster than setting fan speed on the remote controller (\*). The remote controller displays "🌀".

\* Indoor fan speed becomes faster than setting fan speed on the remote controller even when 🌀 or 🌀 is selected.

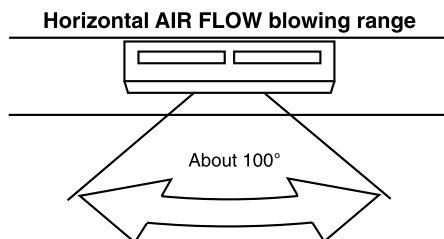

## 9-6. TIMER OPERATION

### 1. How to set the timer

- Press OPERATE/STOP (ON/OFF) button to start the air conditioner.
- Check that the current time is set correctly.

**NOTE:** Timer operation will not work without setting the current time. Initially "AM0:00" blinks at the current time display of TIME MONITOR, so set the current time correctly with CLOCK SET button.

- Press ON/OFF TIMER buttons to select the operation.
  - "ON-TIMER" button...AUTO START operation (ON timer)
  - "OFF-TIMER" button...AUTO STOP operation (OFF timer)
- Press HR. and MIN. button to set the timer. Time setting is 10-minute units.
  - HR. and MIN. button will work when "⊖ → |" or "⊖ → ○" mark is flashing.
  - These marks disappear in 1 minute.
  - After setting the ON timer, check that OPERATION INDICATOR lamp of the indoor unit lights.

**NOTE1:** Be sure to place the remote controller at the position where its signal can reach the air conditioner even during TIMER operation, or the set time may deviate within the range of about 10 minutes.

**NOTE2:** Reset the timer in the following cases, or the set time may deviate and other malfunctions may occur.

- A power failure occurs.
- The circuit breaker functions.

### 2. Cancel

TIMER setting can be cancelled with ON/OFF TIMER buttons.

To cancel ON timer, press "ON-TIMER" button.

To cancel OFF timer, press "OFF-TIMER" button.

TIMER is cancelled and the display of set time disappears.



## PROGRAM TIMER

- OFF timer and ON timer can be used in combination.
- "↑" and "↓" display shows the order of OFF timer and ON timer operation.

(Example 1) The current time is 8:00 PM.  
The unit turns OFF at 11:00 PM, and ON at 6:00 AM.

(Example 2) The current time is 11:00 AM.  
The unit turns ON at 5:00 PM, and OFF at 9:00 PM.

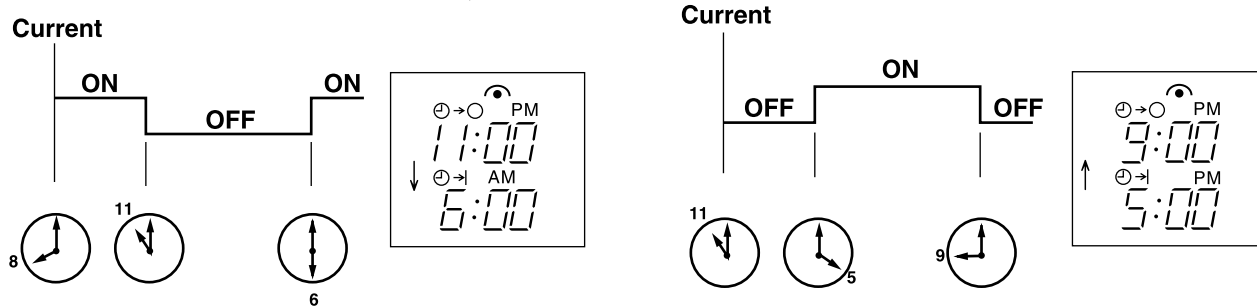

NOTE: TIMER setting will be cancelled by failure or breaker functioning.

### 9-7. EMERGENCY/TEST OPERATION

In case of test run operation or emergency operation, use EMERGENCY OPERATION switch on the front of the indoor unit. Emergency operation is available when the remote controller is missing, has failed or batteries of remote controller run down. The unit will start and OPERATION INDICATOR lamp will light.

The first 30 minutes of operation is the test run operation. This operation is for servicing. The indoor fan speed runs at High speed and the temperature control does not work.

After 30 minutes of test run operation, the system shifts to EMERGENCY COOL MODE with a set temperature of 24°C.

The fan speed shifts to Med. speed.

The coil frost prevention works even in the test run or the emergency operation.

In the test run or emergency operation, the horizontal vane operates in VANE AUTO ( @ ) mode.

Emergency operation continues until EMERGENCY OPERATION switch is pressed again or the unit receives any signal from the remote controller. In case of latter, normal operation will start.

NOTE: Do not press EMERGENCY OPERATION switch during normal operation.

- The following indication applies regardless of shape of the indicator.

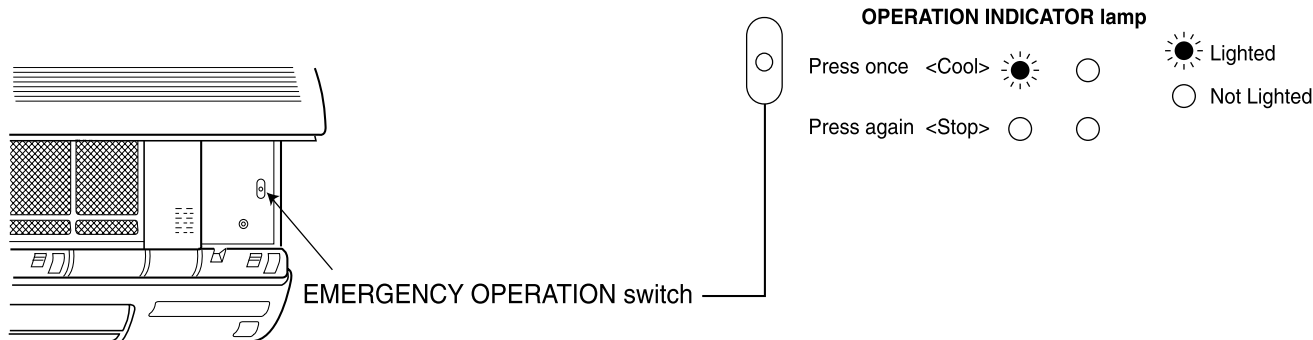

### 9-8. 3-MINUTE TIME DELAY OPERATION

When the system turns OFF, compressor will not restart for 3 minutes as 3-minute time delay function operates to protect compressor from overload.

**MS-GD80VB****10-1. CAUTIONS ON TROUBLESHOOTING****1. Before troubleshooting, check the following:**

- (1) Check the power supply voltage.
- (2) Check the indoor/outdoor connecting wire for mis-wiring.

**2. Take care the following during servicing.**

- (1) Before servicing the air conditioner, be sure to turn OFF the main unit first with the remote controller, and after confirming the horizontal vane is closed, turn OFF the breaker and/or disconnect the power plug.
- (2) Be sure to turn OFF the power supply before removing the panel, the cabinet, the top panel, and the electronic control P.C. board.
- (3) When removing the electronic control P.C. board, hold the edge of the board with care NOT to apply stress on the components.
- (4) When connecting or disconnecting the connectors, hold the housing of the connector. DO NOT pull the lead wires.

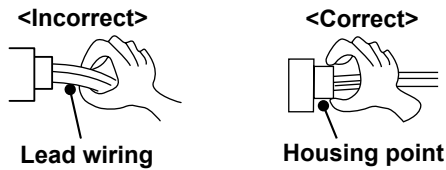
**3. Troubleshooting procedure**

- (1) First, check if the OPERATION INDICATOR lamp on the indoor unit is flashing ON and OFF to indicate an abnormality. To make sure, check how many times the OPERATION INDICATOR lamp is flashing ON and OFF before starting service work.
- (2) Before servicing check, that the connector and terminal are connected properly.
- (3) When the electronic control P.C. board seems to be defective, check the copper foil pattern for disconnection and the components for bursting and discoloration.
- (4) When troubleshooting, refer to 10-2. and 10-3.

**4. How to replace batteries**

Weak batteries may cause the remote controller malfunction.

In this case, replace the batteries to operate the remote controller normally.

- ① Remove the front lid and insert batteries. Then reattach the front lid.

- ② Press the RESET button with a thin instrument, and then use the remote controller.

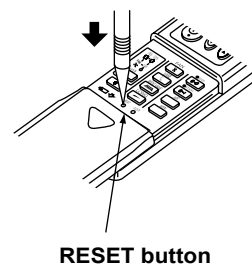
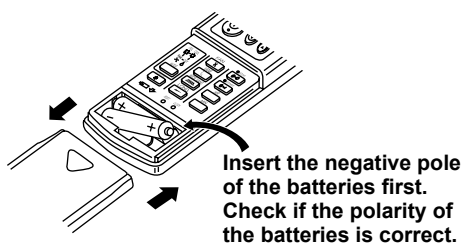

- NOTE:** 1.If the RESET button is not pressed, the remote controller may not operate correctly.  
2. Do not use the leaking batteries.

## 10-2. INSTRUCTION OF TROUBLESHOOTING

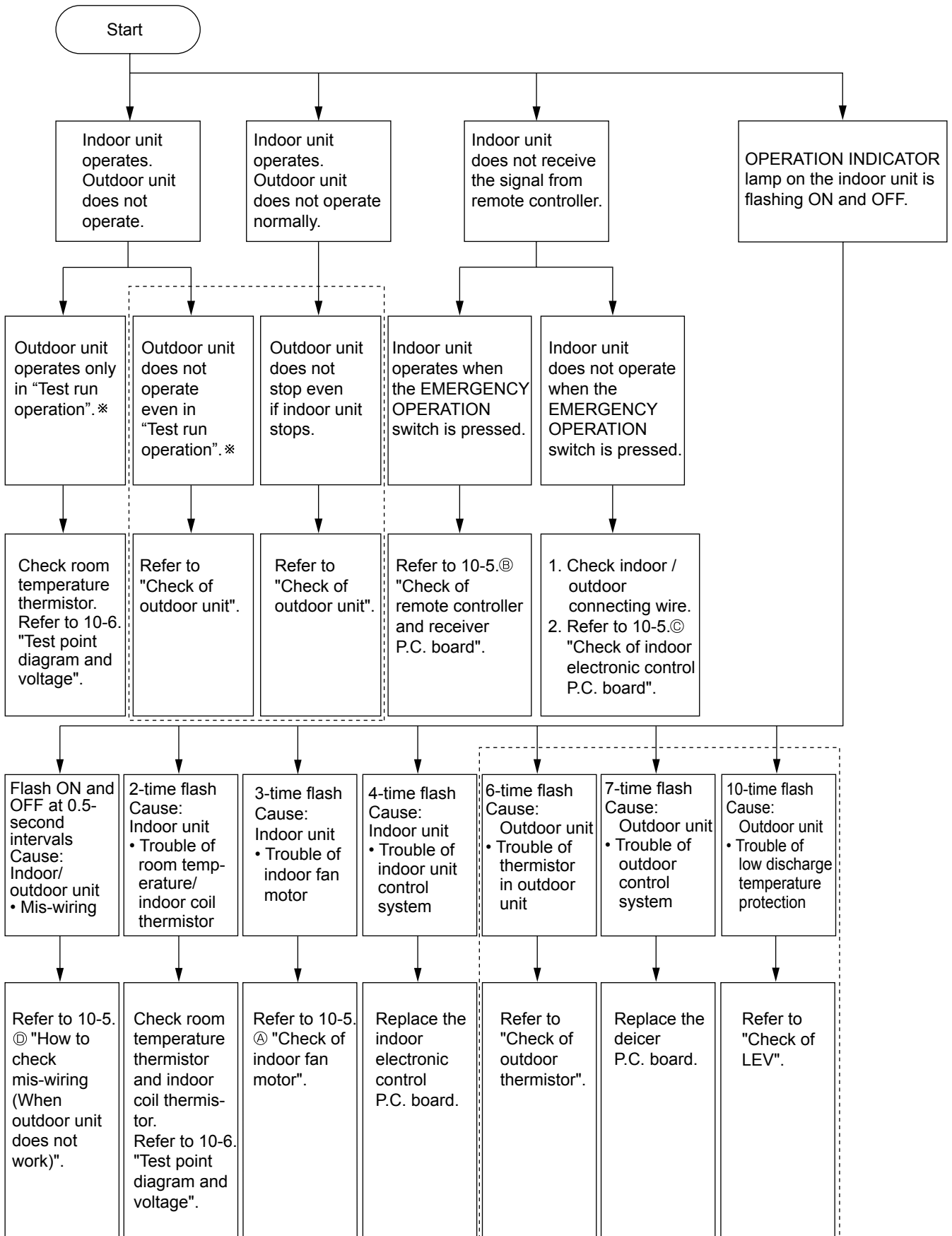

⋯ Refer to outdoor unit service manual.

\* "Test run operation" means the operation within 30 minutes after EMERGENCY OPERATION switch is pressed.

### 10-3. TROUBLESHOOTING CHECK TABLE

- Before taking measures, make sure that the symptom reappears for accurate troubleshooting.  
When the indoor unit has started operation and the following detection method has detected an abnormality (the first detection after the power ON), the indoor electronic control P.C. board turns OFF the indoor fan motor with the OPERATION INDICATOR lamp flashing.

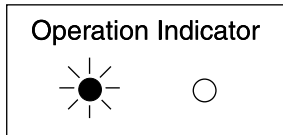

**Lighted**



**Not lighted**

• Flashing of the OPERATION INDICATOR lamp (the left-hand side lamp) indicates possible abnormalities.

No.	Abnormal point	Operation indicator lamp	Symptom	Condition	Remedy
1	Mis-Wiring	0.5-second ON ●○●○●○●○ 0.5-second OFF	Outdoor unit does not operate.	3 minutes after power supply turns ON, serial signal is not received.	• Refer to 10-5. ① "How to check mis-wiring".
2	Indoor coil thermistor	2-time flash ●○●○●○●○●○●○ 2.5-second OFF	Outdoor unit does not operate.	Indoor coil/room temperature thermistor detects short or open circuit every 8 seconds during operation.	• Refer to the characteristics of indoor coil thermistor, and room temperature thermistor on 10-6.
	Room temperature thermistor				
3	Indoor fan motor	3-time flash ●○●○●○●○●○●○●○●○ 2.5-second OFF	Indoor fan repeats 12 seconds ON and 3 minutes OFF. When the indoor fan breaks, the fan keeps stopping.	The rotational frequency feedback signal is not emitted for 12 seconds after indoor fan breaks, the fan keeps stopping.	• Refer to 10-5. ② "Check of indoor fan motor".
4	Indoor control system	4-time flash ●○●○●○●○●○●○●○●○ 2.5-second OFF	Outdoor unit does not operate.	It cannot properly read data in the nonvolatile memory of the indoor electronic control P.C. board.	• Check the indoor electronic control P.C. board.
5	Outdoor thermistor	6-time flash ●○●○●○●○●○●○●○●○ 2.5-second OFF	Outdoor unit does not operate.	<Thermistor short> Thermistors are abnormal when they short after compressor start-up. <Thermistor open> Thermistors are abnormal when they open after compressor start-up. However, discharge temperature thermistor is abnormal when open circuit is detected more than 10 minutes after compressor start-up.	• Check the deicer P.C. board. • Reconnect the connector. Refer to "Check of outdoor thermistor". Refer to outdoor service manual.
6	Outdoor control system	7-time flash ●○●○●○●○●○●○●○●○ 2.5-second OFF	Outdoor unit does not operate.	It cannot properly read data in the nonvolatile memory of the deicer P.C. board.	• Check the deicer P.C. board. Refer to outdoor service manual.
7	Low discharge temperature protection	10-time flash ●○●○●○●○●○●○●○●○ 2.5-second OFF	Outdoor unit does not operate.	Discharge temperature has been 50°C or less on cool operation.	• Refer to "Check of LEV". • Check refrigerant circuit and refrigerant amount. Refer to outdoor service manual.

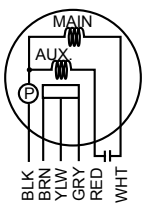
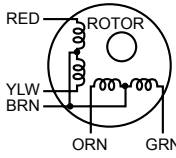

## 10-4. TROUBLE CRITERION OF MAIN PARTS MS-GD80VB

Part name	Check method and criterion	Figure					
Room temperature thermistor (RT11)	Measure the resistance with a tester. (Part temperature 10°C ~ 30°C)						
Indoor coil thermistor (RT12 (main), RT13 (sub))	Refer to 10-6. "Test point diagram and voltage", "Indoor electronic control P.C. board", for the chart of thermistor.						
Indoor fan motor (MF)	Measure the resistance between the terminals with a tester. (Part temperature 10°C ~ 30°C)						
	<table border="1"> <thead> <tr> <th>Color of lead wire</th> <th>Normal</th> </tr> </thead> <tbody> <tr> <td>WHT – BLK</td> <td>132 Ω ~ 144 Ω</td> </tr> <tr> <td>BLK – RED</td> <td>152 Ω ~ 166 Ω</td> </tr> </tbody> </table>		Color of lead wire	Normal	WHT – BLK	132 Ω ~ 144 Ω	BLK – RED
Color of lead wire	Normal						
WHT – BLK	132 Ω ~ 144 Ω						
BLK – RED	152 Ω ~ 166 Ω						
INNER PROTECTOR 135± 5 °C OPEN	Measure the voltage power ON.						
	<table border="1"> <thead> <tr> <th>Color of lead wire</th> <th>Normal</th> </tr> </thead> <tbody> <tr> <td>BRN – YLW</td> <td>4.5 ~ 5.5 V</td> </tr> <tr> <td>YLW – GRN</td> <td>(When fan revolved one time) 0 V → 5 V → 0 V (Approx.)</td> </tr> </tbody> </table>		Color of lead wire	Normal	BRN – YLW	4.5 ~ 5.5 V	YLW – GRN
Color of lead wire	Normal						
BRN – YLW	4.5 ~ 5.5 V						
YLW – GRN	(When fan revolved one time) 0 V → 5 V → 0 V (Approx.)						
Horizontal vane motor (MV1) Vertical vane motor (MV2)	Measure the resistance between the terminal with a tester. (Part temperature 10°C ~ 30°C)						
	<table border="1"> <thead> <tr> <th>Normal</th> </tr> </thead> <tbody> <tr> <td>282 Ω ~ 306 Ω</td> </tr> </tbody> </table>	Normal	282 Ω ~ 306 Ω				
Normal							
282 Ω ~ 306 Ω							

Ⓟ: INNER PROTECTOR

## 10-5. TROUBLESHOOTING FLOW

When OPERATION INDICATOR lamp flashes 3-time.  
Indoor fan motor does not operate.

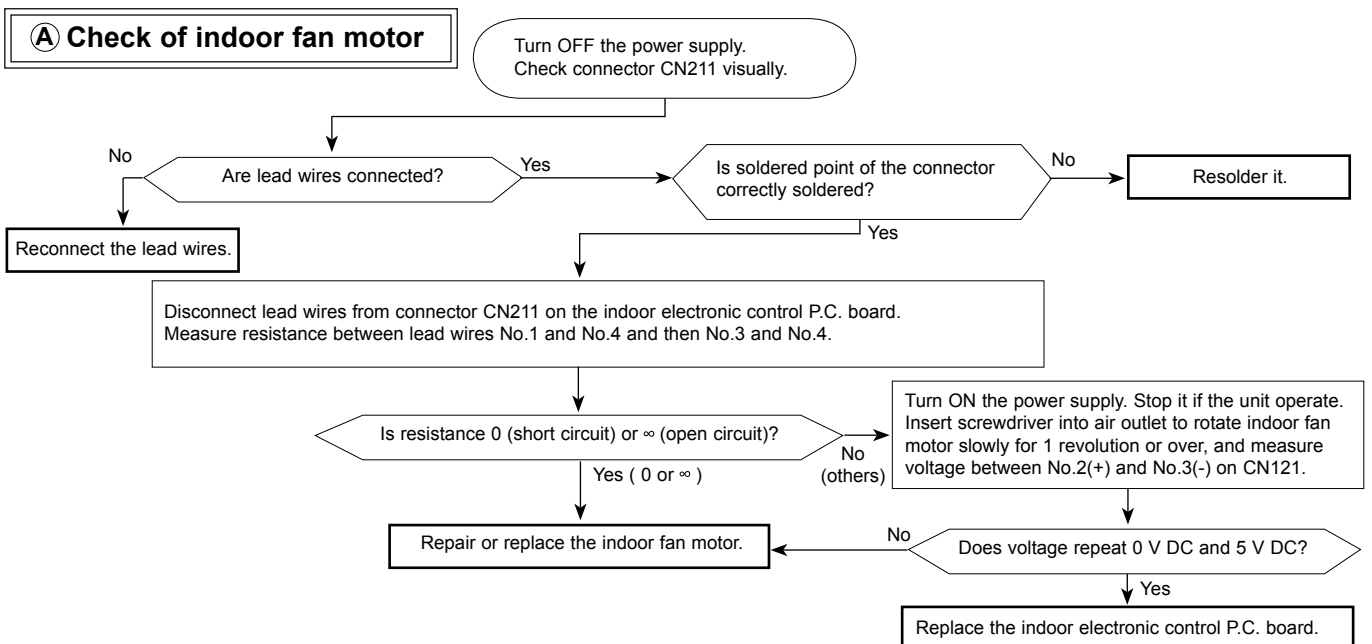

Indoor unit operates by pressing the EMERGENCY OPERATION switch, but does not operate with the remote controller.

### Ⓑ Check of remote controller and receiver P.C. board

※ Check if the remote controller is exclusive for this air conditioner.

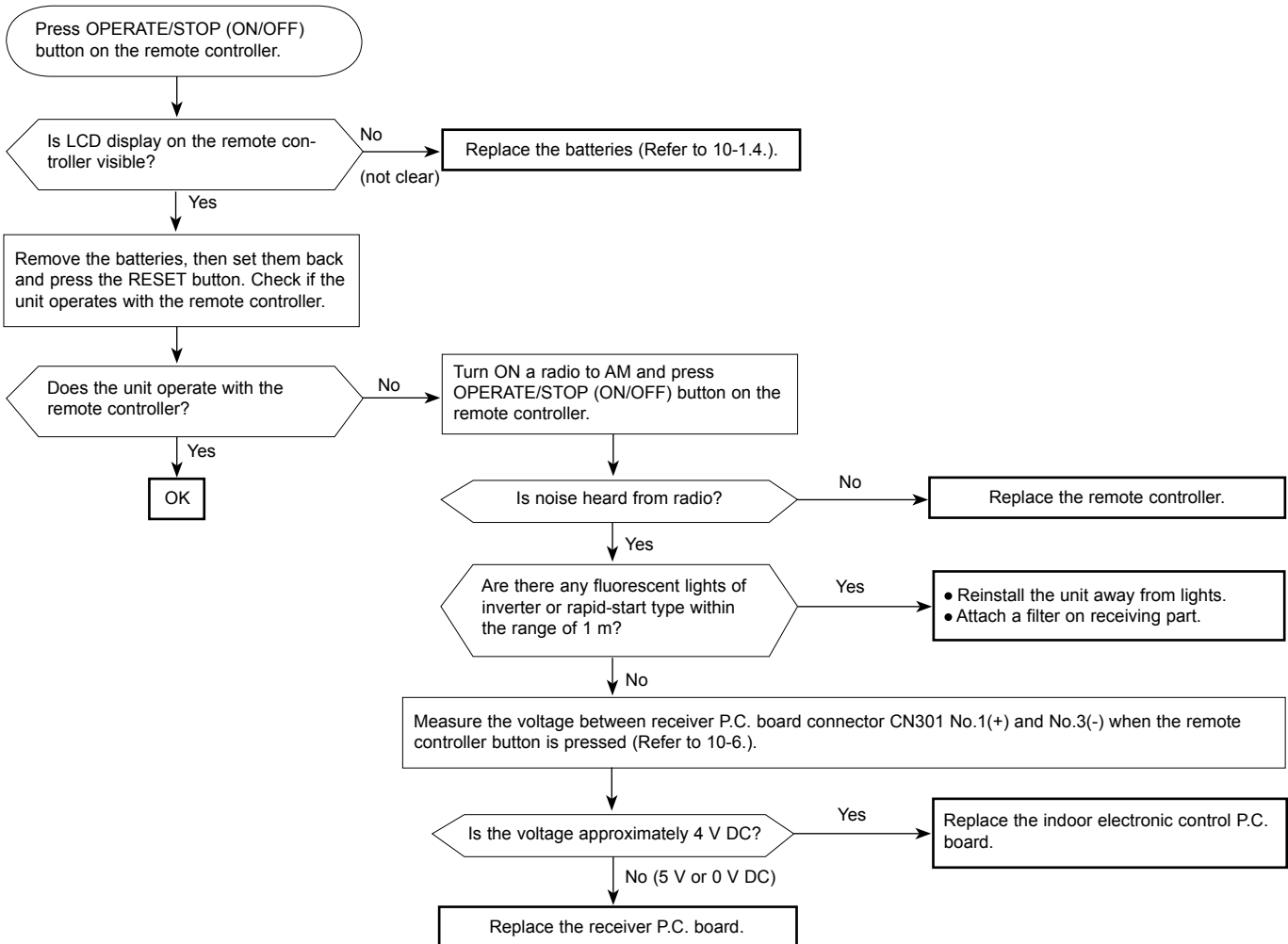

The unit doesn't operate with the remote controller. Also, the OPERATION INDICATOR lamp does not light up by pressing the EMERGENCY OPERATION switch.

**© Check of indoor electronic control P.C. board**

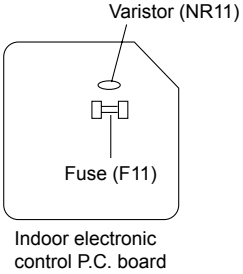
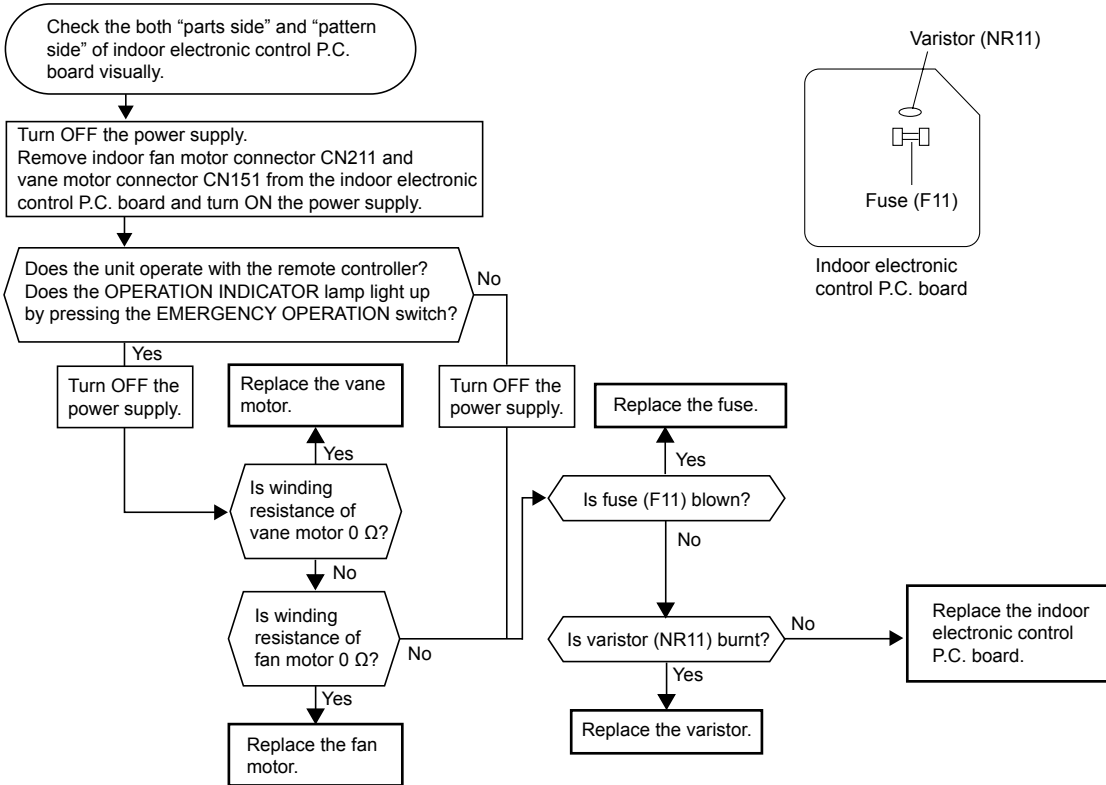

When OPERATION INDICATOR lamp flashes ON and OFF in every 0.5-second.  
Outdoor unit does not operate.

**D How to check mis-wiring**

\* Short circuit of JPG and JPS on the indoor electronic control P.C. board enables self-check to be displayed in 3 seconds.

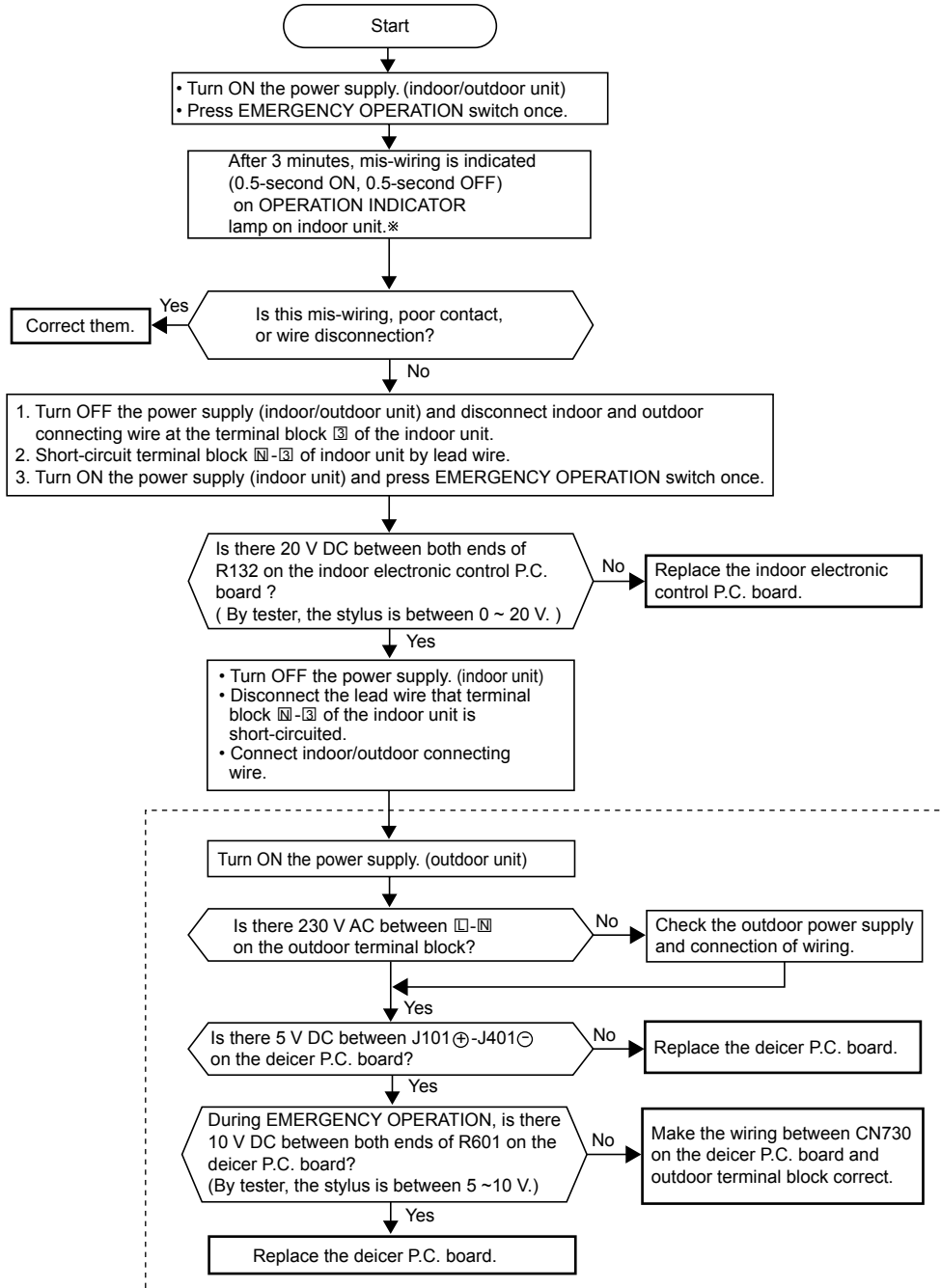

Refer to outdoor unit service manual.

**10-6. TEST POINT DIAGRAM AND VOLTAGE  
MS-GD80VB  
Indoor electronic control P.C. board**

**NOTE:** There are two types of electronic control P.C. boards (TYPE 1/TYPE 2). They are both compatible with MS-GD80VB.

**TYPE 1**

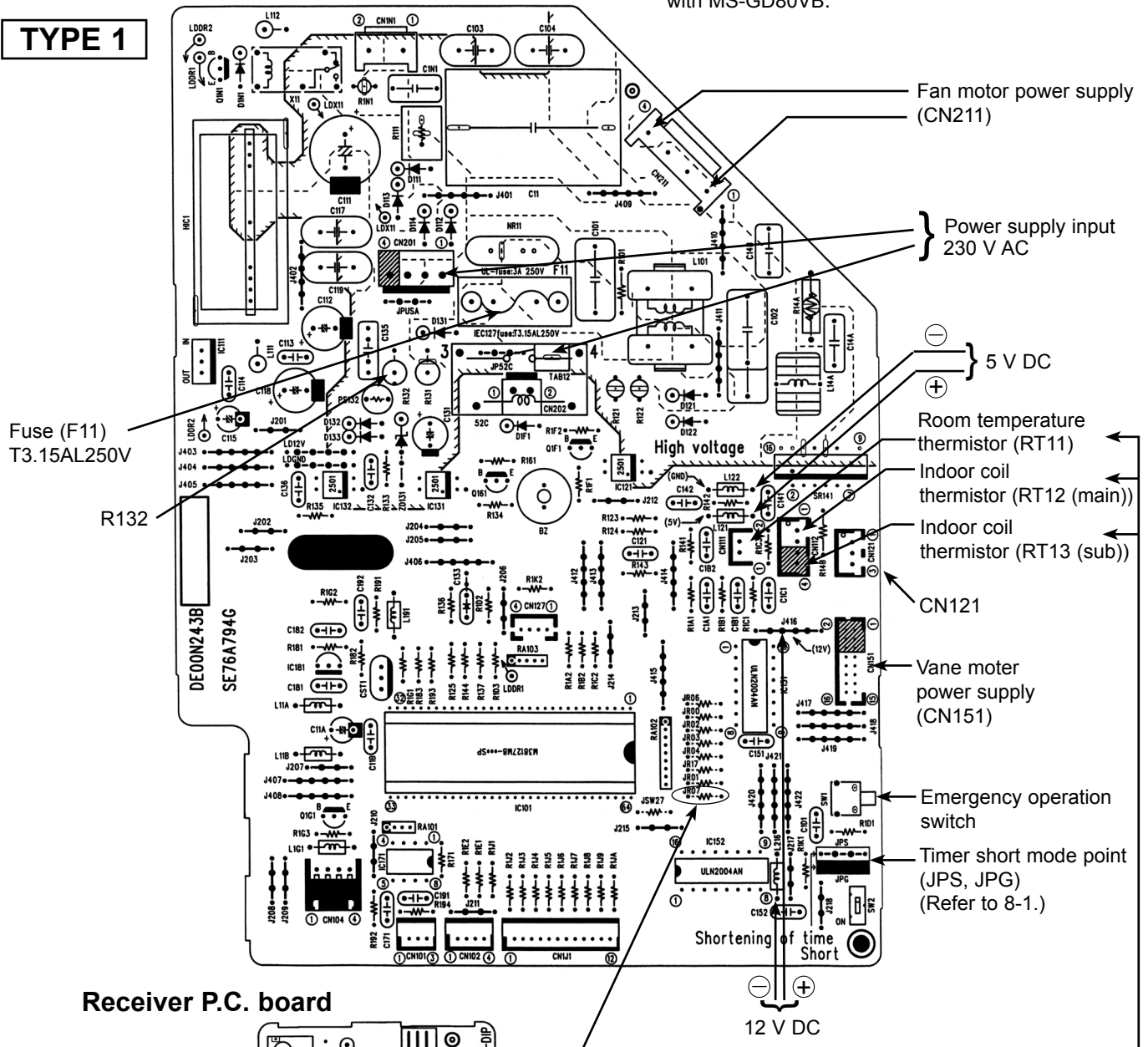

**Indoor coil thermistor (RT12 (main), RT13 (sub))  
Room temperature thermistor (RT11)**

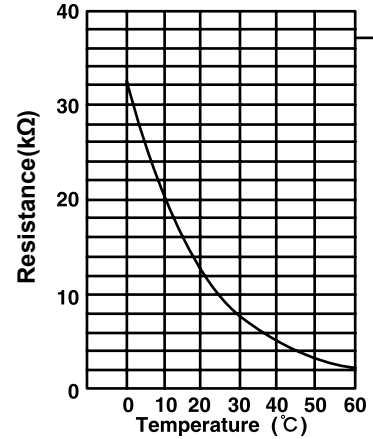

To disable "Auto restart function",  
solder jumper wire to JR07.  
(Refer to 8-3.)

**MS-GD80VB**  
Indoor electronic control P.C. board

**TYPE 2**

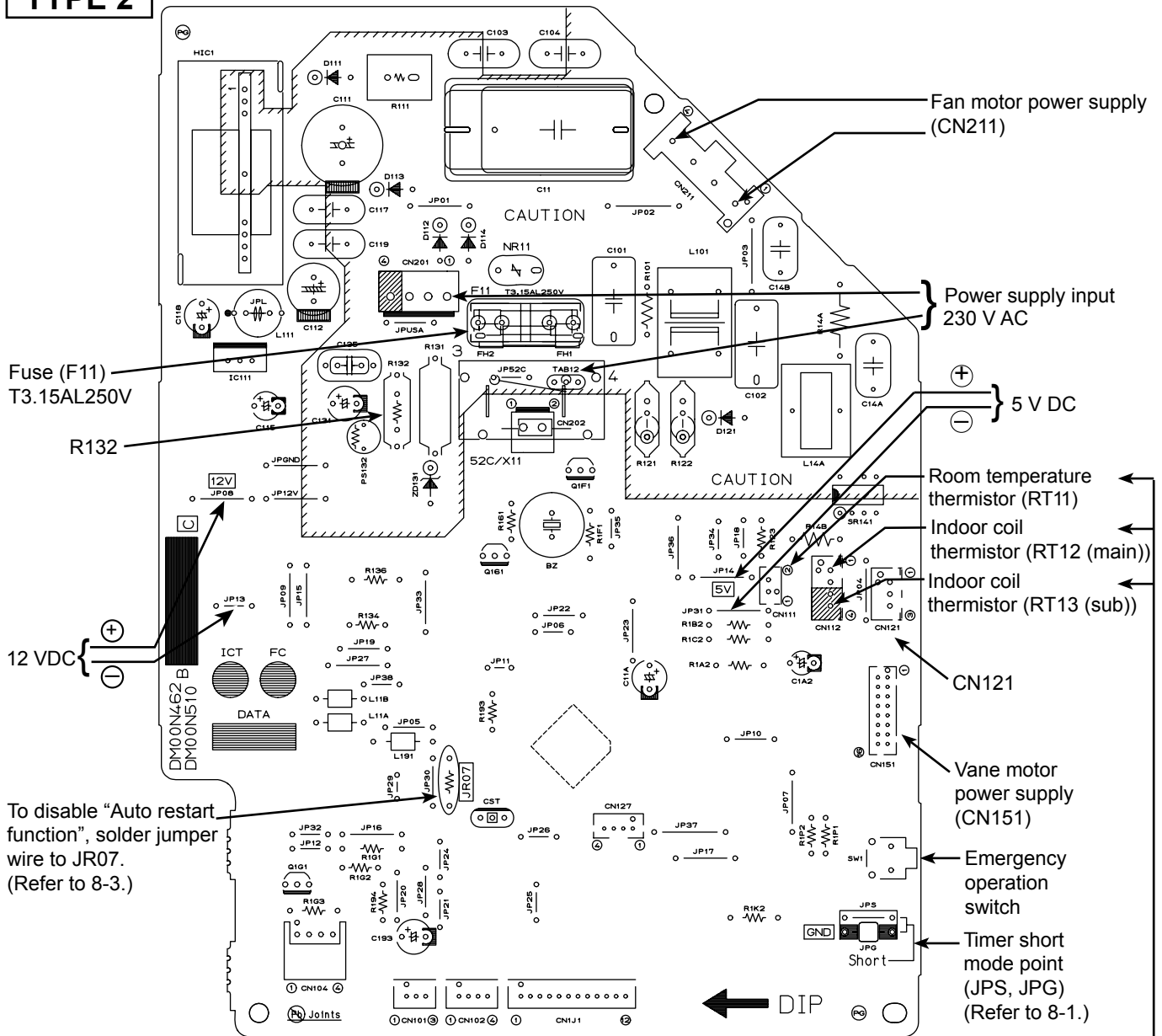

Fuse (F11)  
T3.15AL250V

R132

12 VDC  
DM00N462 B  
DM00N510  
ICT  
FC  
DATA  
To disable "Auto restart function", solder jumper wire to JR07.  
(Refer to 8-3.)

Fan motor power supply  
(CN211)

Power supply input  
230 V AC

5 V DC

Room temperature thermistor (RT11)

Indoor coil thermistor (RT12 (main))

Indoor coil thermistor (RT13 (sub))

CN121

Vane motor power supply  
(CN151)

Emergency operation switch

Timer short mode point  
(JPS, JPG)  
(Refer to 8-1.)

**Receiver P.C. board**

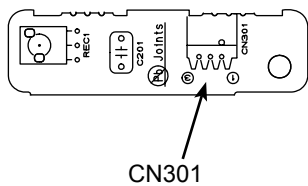

CN301

Indoor coil thermistor (RT12 (main), RT13 (sub))  
Room temperature thermistor (RT11)

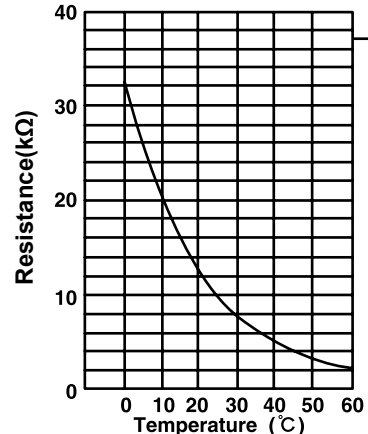

## &lt;"Terminal with locking mechanism" Detaching points&gt;

The terminal which has the locking mechanism can be detached as shown below.  
There are two types ( Refer to (1) and (2)) of the terminal with locking mechanism.  
The terminal without locking mechanism can be detached by pulling it out.  
Check the shape of the terminal before detaching.

(1) Slide the sleeve and check if there is a locking lever or not.

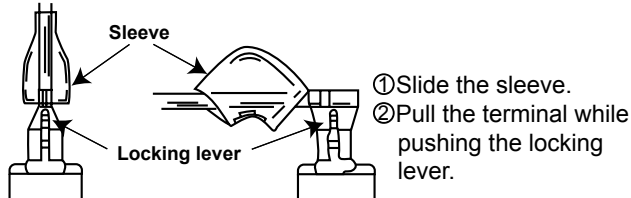

(2) The terminal with this connector has the locking mechanism.

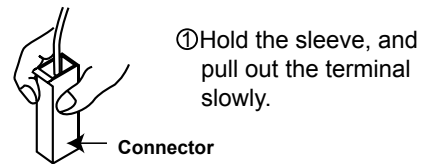

## 11-1. MS-GD80VB

**NOTE:** Turn OFF power supply before disassembly.

OPERATING PROCEDURE	PHOTOS
<p><b>1. Removing the panel</b></p> <ol style="list-style-type: none"> <li>(1) Remove the screw caps of the panel. Remove the screws of the panel.</li> <li>(2) Pull the panel down to your side slightly and unhook the catches at the top.</li> <li>(3) Remove the screw of the corner box. Remove the corner box.</li> </ol>	<p><b>Photo 1</b></p> <p>Screws of the panel Screw of the corner box</p>
<p><b>2. Removing the electronic control P.C. board, the receiver P.C. board and the display P.C. board</b></p> <ol style="list-style-type: none"> <li>(1) Remove the panel and the corner box. (Refer to 1.)</li> <li>(2) Remove the screw of the electrical cover. Remove the electrical cover.</li> <li>(3) Remove the screws of the V.A. clamp. Remove the V.A. clamp.</li> <li>(4) Remove the screw of the terminal block.</li> <li>(5) Remove the screws of the earth wire.</li> <li>(6) Disconnect all the connectors and all the lead wires on the electronic control P.C. board.</li> <li>(7) Remove the R.L holder.</li> <li>(8) Remove the electronic control P.C. board.</li> <li>(9) Open the R.L holder, remove the receiver P.C. board and the display P.C. board.</li> </ol>	<p><b>Photo 2</b></p> <p>Screws of the earth wire Fan motor connectors Vane motor connector Indoor electronic control P.C. board Screw of the electrical cover R.L holder Screw of the terminal block Receiver P.C. board Screw of the V.A. clamp</p>

## OPERATING PROCEDURE

### 3. Removing the electrical box

- (1) Remove the panel and the corner box. (Refer to 1.)
- (2) Remove the electrical cover. (Refer to 2.)
- (3) Disconnect the connector of the indoor coil thermistor.
- (4) Disconnect the motor connector (CN211 and CN121) and the vane motor connector (CN151) on the electronic control P.C. board.
- (5) Remove the screws of earth wire.
- (6) Remove the fan motor lead wire and indoor coil thermistor from the electrical box.
- (7) Remove the lead wire of vane motor from the bottom of electrical box.
- (8) Remove the screw of the electrical box and remove the electrical box.

### 4. Removing the vane motor

- (1) Remove the panel and the corner box. (Refer to 1.)
- (2) Remove the electrical cover. (Refer to 2.)
- (3) Remove the lead wire of vane motor. (Refer to 3.)
- (4) Remove the R.L. holder.
- (5) Pull out the drain hose from the nozzle assembly and remove the nozzle assembly.
- (6) Remove the screws of the vane motor and disconnect the connector.
- (7) Remove the vane motor.

**Photo 5** Screws of the vane motor

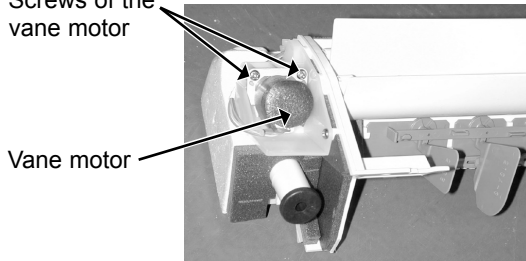

### 5. Removing the line flow fan and the indoor fan motor

- (1) Remove the panel and the corner box. (Refer to 1.)
- (2) Remove the electrical box. (Refer to 3.)
- (3) Pull out the drain hose from the nozzle assembly and remove the nozzle assembly.
- (4) Remove the water cut.
- (5) Slide the hole cover and remove the hole cover.
- (6) Remove the hexagon socket set screw from the line flow fan.
- (7) Remove the screws of the fan motor and remove the fan motor. (Be careful not to drop the fan motor because it is heavy.)
- (8) Remove the screws of the left side of the heat exchanger.
- (9) Lift the left side of the heat exchanger.
- (10) Remove the line flow fan.

**Photo 8**

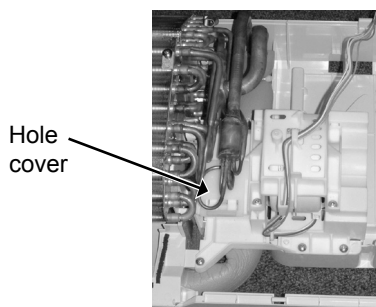

## PHOTOS

**Photo 3** Screws of the earth wire



Screw of the electrical cover  
Screw of the electrical box

**Photo 4**

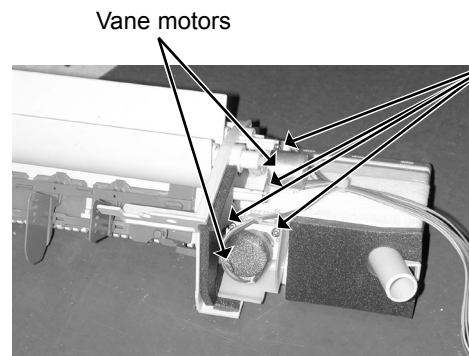

Vane motors

Screws of the vane motor

**Photo 6**

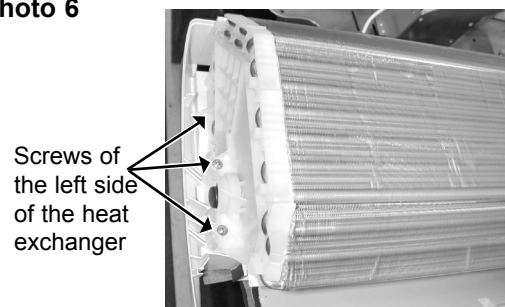

Screws of the left side of the heat exchanger

**Photo 7**

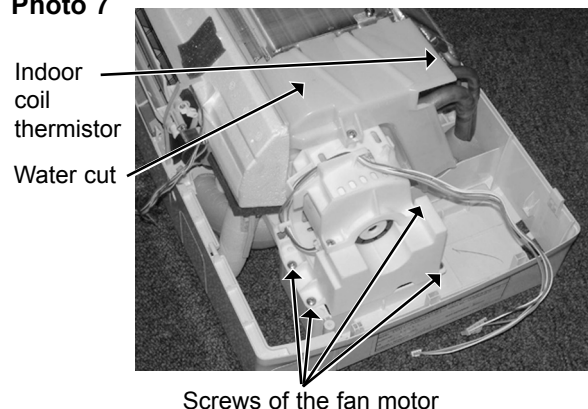

Indoor coil thermistor  
Water cut

Screws of the fan motor







HEAD OFFICE: TOKYO BLDG., 2-7-3, MARUNOUCHI, CHIYODA-KU, TOKYO 100-8310, JAPAN

© Copyright 2008 MITSUBISHI ELECTRIC ENGINEERING CO., LTD  
Distributed in Aug. 2011. No.OBH511 REVISED EDITION-A  
Distributed in Apr. 2008. No.OBH511 6  
Made in Japan

New publication, effective Aug. 2011  
Specifications subject to change without notice.