

Revision C:

- MXZ-2B30VA- [E1] and MXZ-2B52VA- [E1] have been added.

Please void OBB554 REVISED EDITION-B.

OUTDOOR UNIT PARTS CATALOG



**No. OBB554
REVISED EDITION-C**

Models

MXZ-2B30VA - [E1]

MXZ-2B40VA - [E1]

MXZ-2B52VA - [E1]

MXZ-3B54VA - [E1]

MXZ-3B68VA - [E1]

MXZ-4B71VA - [E1]

MXZ-4B80VA - [E1]

MXZ-5B100VA - [E1]

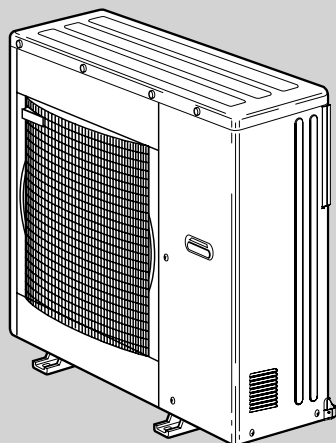

MXZ-4B80VA

CONTENTS

1. RoHS PARTS LIST..... 2
2. OPTIONAL PARTS..... 14

SERVICE MANUAL (OBH554)

NOTE:

RoHS compliant products have <G> mark on the spec name plate.



Revision A :

- MXZ-3B54VA- [E1], MXZ-3B68VA- [E1] and MXZ-4B71VA- [E1] have been added.
- Power board of MXZ-4B80VA- [E1] and MXZ-5B100VA- [E1] has been changed.

Revision B :

- MXZ-2B40VA- [E1] has been added.

Revision C :

- MXZ-2B30VA- [E1] and MXZ-2B52VA- [E1] have been added.

1

RoHS PARTS LIST

MXZ-2B30VA MXZ-2B40VA MXZ-2B52VA

1-1. OUTDOOR UNIT STRUCTURAL PARTS AND FUNCTIONAL PARTS

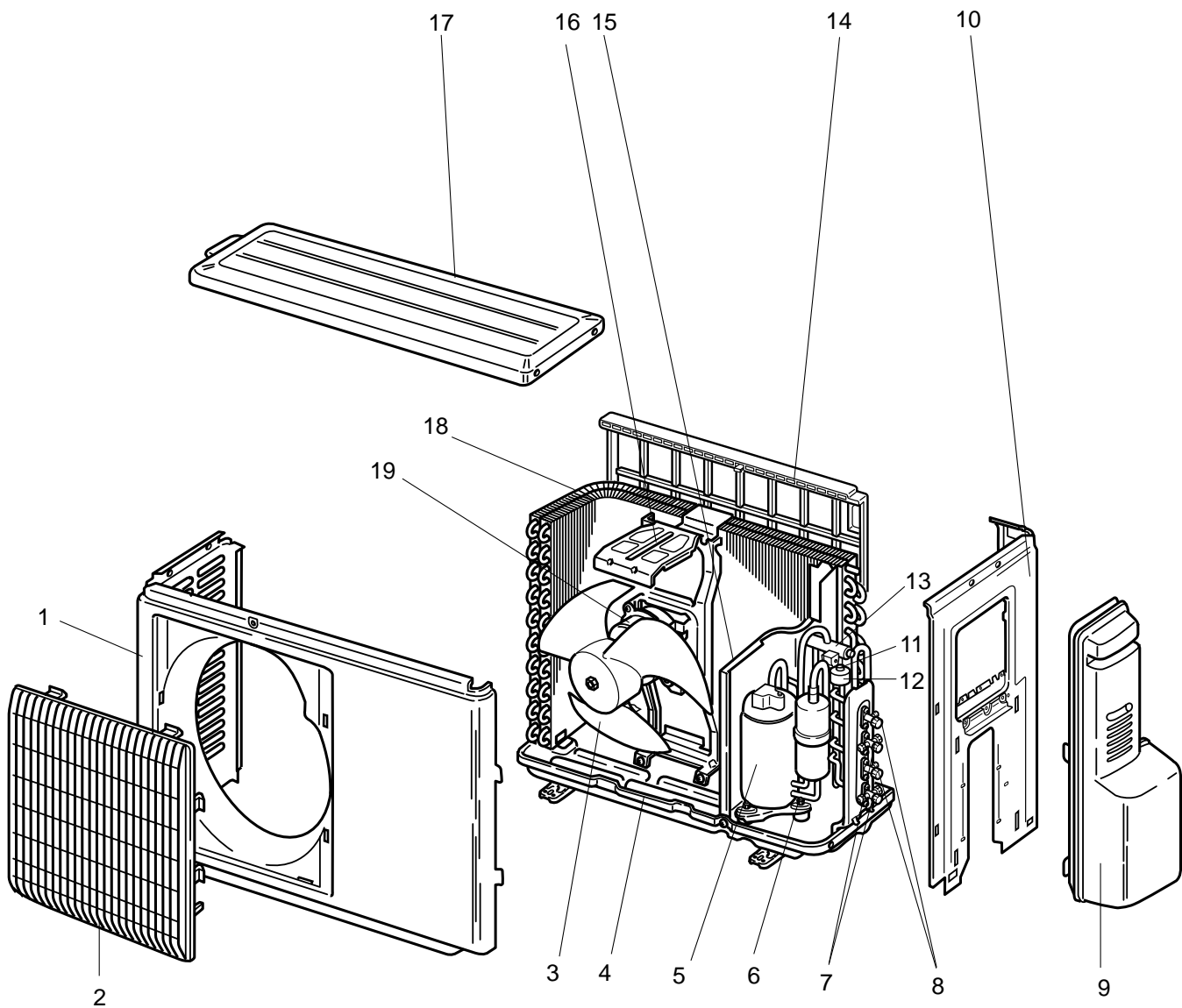

MXZ-2B30VA MXZ-2B40VA MXZ-2B52VA

1-1. OUTDOOR UNIT STRUCTURAL PARTS AND FUNCTIONAL PARTS

Part numbers that are circled are not shown in the illustration.

No.	ROHS	Part No.	Part Name	Symbol in Wiring Diagram	Q'ty/unit			Remarks
					MXZ-			
					2B30VA- [E1]	2B40VA- [E1]	2B52VA- [E1]	
1	G	E12 927 232	CABINET		1		1	
	G	E12 A89 232	CABINET			1		
2	G	E12 927 521	GRILLE		1	1	1	
3	G	E12 927 501	PROPELLER		1	1	1	
4	G	E12 A45 290	BASE		1		1	
	G	E12 F24 290	BASE			1		
5	G	E12 F24 900	COMPRESSOR	MC		1		KNB092FFDHC
	G	E12 E05 900	COMPRESSOR	MC			1	SNB130FGBHT
	G	E12 D75 900	COMPRESSOR	MC	1			KNB073FGDHC
6	G	E12 065 506	COMPRESSOR RUBBER SET		3	3		3RUBBERS/SET
	G	E12 C34 506	COMPRESSOR RUBBER SET				3	3RUBBERS/SET
7	G	E12 927 661	STOP VALVE (GAS)		2	2	2	φ 9.52
8	G	E12 927 662	STOP VALVE (LIQUID)		2	2	2	φ 6.35
9	G	E12 A47 245	SERVICE PANEL		1	1	1	
10	G	E12 A47 233	BACK PANEL		1	1	1	
11	G	E12 735 640	EXPANSION VALVE		1	1	1	ROOM B
12	G	E12 F25 493	EXPANSION VALVE COIL	LEV B	1	1	1	
13	G	E12 A47 961	4-WAY VALVE				1	
	G	E12 927 961	4-WAY VALVE		1	1		
14	G	E12 929 523	CONDENSER NET				1	
	G	E12 838 523	CONDENSER NET		1			
	G	E12 900 523	CONDENSER NET			1		
15	G	E12 929 293	SEPARATOR			1	1	
	G	E12 F24 293	SEPARATOR		1			
16	G	E12 929 515	MOTOR SUPPORT			1	1	
	G	E12 927 515	MOTOR SUPPORT		1			
17	G	E12 927 297	TOP PANEL		1	1	1	
18	G	E12 A47 630	OUTDOOR HEAT EXCHANGER				1	
	G	E12 B70 630	OUTDOOR HEAT EXCHANGER		1			
	G	E12 F24 630	OUTDOOR HEAT EXCHANGER			1		
19	G	E12 A47 301	OUTDOOR FAN MOTOR	MF	1	1	1	RC0J50- □□
⑳	G	E12 339 936	CAPILLARY TUBE			4	4	φ3.0×φ1.4×600
	G	E12 838 936	CAPILLARY TUBE		2	2	2	φ3.0×φ2.0×200
㉑	G	E12 735 640	EXPANSION VALVE		1	1	1	ROOM A
㉒	G	E12 F24 493	EXPANSION VALVE COIL	LEV A	1	1	1	

MXZ-2B30VA MXZ-2B40VA MXZ-2B52VA
1-2. OUTDOOR UNIT ELECTRICAL PARTS

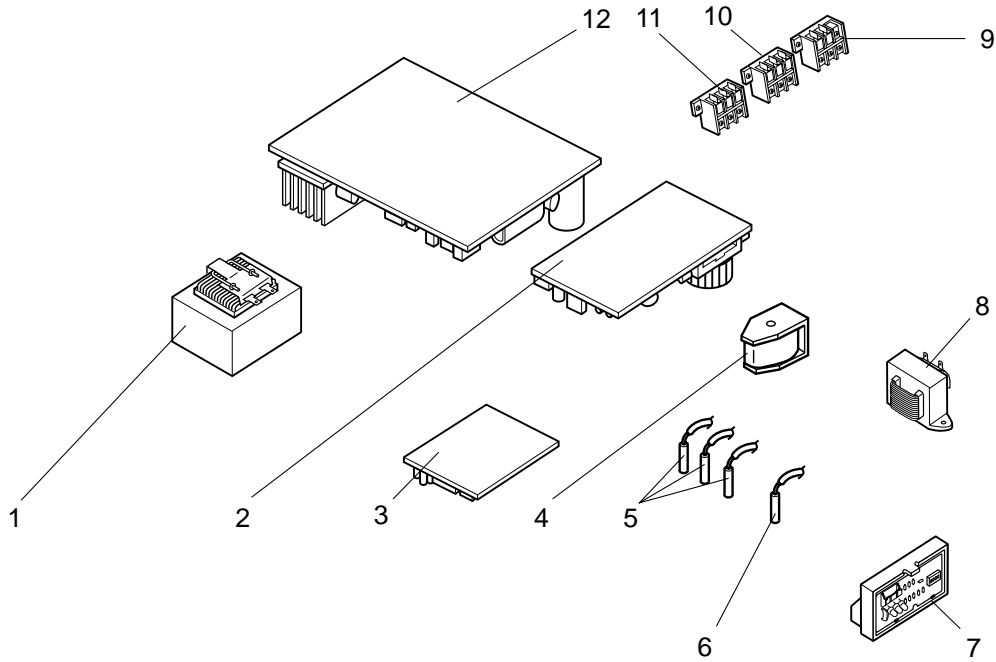

Part numbers that are circled are not shown in the illustration.

No.	RoHS	Part No.	Part Name	Symbol in Wiring Diagram	Q'ty/unit			Remarks
					MXZ-2B30VA- [E1]	MXZ-2B40VA- [E1]	MXZ-2B52VA- [E1]	
1	G	E12 838 337	REACTOR	L64	1	1	1	10A 23mH
2	G	E12 F23 440	POWER P.C. BOARD		1	1	1	
3	G	E12 F23 454	INTERFACE P.C. BOARD		1	1	1	
4	G	E12 A47 490	R.V. COIL	21S4	1	1	1	
5	G	E12 A47 308	THERMISTOR SET	RT61,62,68	1	1	1	DEFROST, DISCHARGE OUTDOOR HEAT EXCHANGER
6	G	E12 A47 309	AMBIENT TEMPERATURE THERMISTOR	RT65	1	1	1	
7	G	E12 A47 329	DISPLAY P.C. BOARD		1	1	1	
8	G	E12 A47 337	REACTOR	L65	1	1	1	2A 25mH
9	G	E12 F24 374	TERMINAL BLOCK	TB1	1	1	1	Power supply
10	G	E12 935 374	TERMINAL BLOCK	TB3	1	1	1	Indoor unit connecting
11	G	E12 935 374	TERMINAL BLOCK	TB2	1	1	1	Indoor unit connecting
12	G	E12 F24 451	INVERTER P.C. BOARD			1		Including heat sink and RT64
	G	E12 F25 451	INVERTER P.C. BOARD				1	Including heat sink and RT64
	G	E12 F23 451	INVERTER P.C. BOARD		1			Including heat sink and RT64



MXZ-2B30VA MXZ-2B40VA MXZ-2B52VA
1-3. DRAIN SOCKET

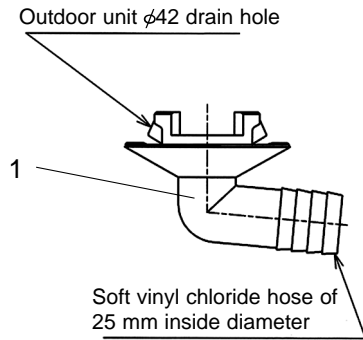

No.	RoHS	Parts No.	Parts Name	Symbol in Wiring Diagram	Q'ty/unit			Remarks
					MXZ-			
					2B30VA- <input type="checkbox"/> E1	2B40VA- <input type="checkbox"/> E1	2B52VA- <input type="checkbox"/> E1	
1	G	E12 838 704	DRAIN SOCKET		1	1	1	

MXZ-3B54VA MXZ-3B68VA MXZ-4B71VA

1-4. OUTDOOR UNIT STRUCTURAL PARTS AND FUNCTIONAL PARTS

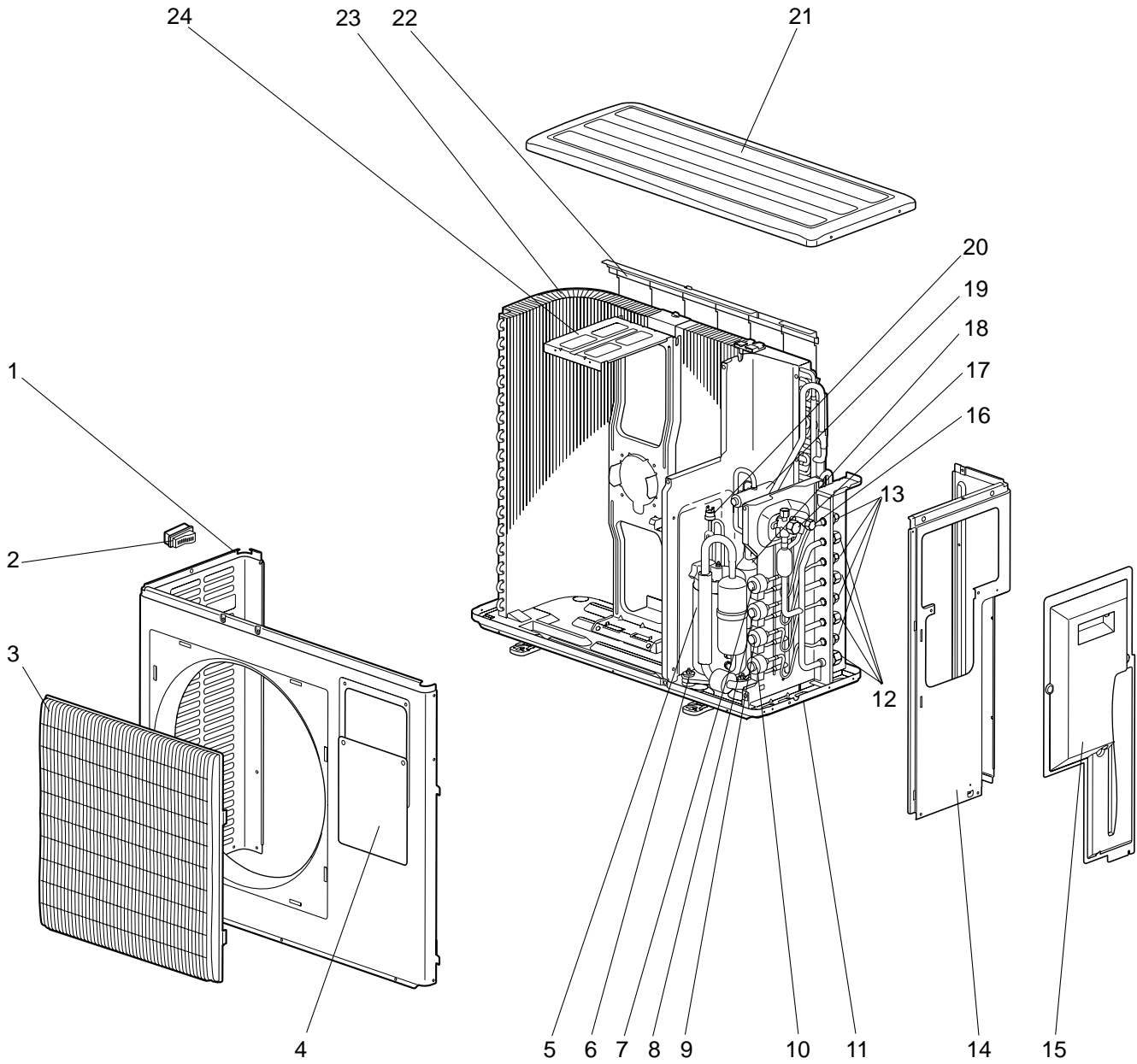

RoHS PARTS LIST (RoHS compliant)

MXZ-3B54VA MXZ-3B68VA MXZ-4B71VA

1-4. OUTDOOR UNIT STRUCTURAL PARTS AND FUNCTIONAL PARTS

Part numbers that are circled are not shown in the illustration.

No.	RoHS	Parts No.	Parts Name	Symbol in Wiring Diagram	Q'ty/unit			Remarks
					MXZ-			
					3B54VA-[E1]	3B68VA-[E1]	4B71VA-[E1]	
1	G	E12 D36 232	CABINET		1	1	1	
2	G	E12 817 009	HANDLE		1	1	1	
3	G	E12 939 521	GRILLE		1	1	1	
4	G	E12 D36 246	SUB PANEL		1	1	1	
5	G	E12 F22 900	COMPRESSOR	MC		1	1	SNB172FEGH1T
	G	E12 F10 900	COMPRESSOR	MC	1			SNB130FGBH1T
6	G	E12 C34 506	COMPRESSOR RUBBER SET		3	3	3	3RUBBERS SET
7	G	E12 851 640	EXPANSION VALVE				1	D room
	G	E12 F21 493	LEV COIL	LEV D			1	D room
8	G	E12 851 640	EXPANSION VALVE		1	1	1	C room
	G	E12 F20 493	LEV COIL	LEV C	1	1	1	C room
9	G	E12 851 640	EXPANSION VALVE		1	1	1	B room
	G	E12 F54 493	LEV COIL	LEV B	1	1	1	B room
10	G	E12 851 640	EXPANSION VALVE		1	1	1	A room
	G	E12 F15 493	LEV COIL	LEV A, E	2	2	2	A, room, LEV E
11	G	E12 939 290	BASE		1	1	1	
12	G	E12 D36 666	UNION(GAS)		3	3	3	φ 9.52
	G	E12 D37 666	UNION(GAS)				1	φ 12.7
13	G	E12 D36 667	UNION(LIQUID)		3	3	4	φ 6.35
14	G	E12 939 233	BACK PANEL		1	1	1	
15	G	E12 D36 245	SERVICE PANEL		1	1	1	
16	G	E12 D36 662	STOP VALVE (LIQUID) 3/8		1	1	1	φ 9.52
17	G	E12 D36 661	STOP VALVE (GAS) 5/8		1	1	1	φ 15.88
18	G	E12 D36 299	OIL SEPARATOR		1	1	1	
19	G	E12 C18 961	4-WAY VALVE		1	1	1	
20	G	E12 853 646	HIGH PRESSURE SWITCH	HPS		1	1	
21	G	E12 819 297	TOP PANEL		1	1	1	
22	G	E12 939 523	REAR GUARD		1	1	1	
23	G	E12 939 630	OUTDOOR HEAT EXCHANGER		1	1	1	
24	G	E12 939 515	MOTOR SUPPORT		1	1	1	
25	G	E12 938 937	CAPILLARY TUBE		8	8	8	φ3.6×φ2.4×500
26	G	E12 939 936	CAPILLARY TUBE		3	3	4	φ4.0×φ2.8×100
27	G	E12 938 936	CAPILLARY TUBE		1	1	1	φ2.5×φ0.6×1000
28	G	E12 C18 959	POWER RECEIVER		1	1	1	
29	G	E12 853 640	EXPANSION VALVE		1	1	1	E

RoHS PARTS LIST (RoHS compliant)

MXZ-3B54VA MXZ-3B68VA MXZ-4B71VA

1-5. OUTDOOR UNIT FUNCTIONAL PARTS AND ELECTRICAL PARTS

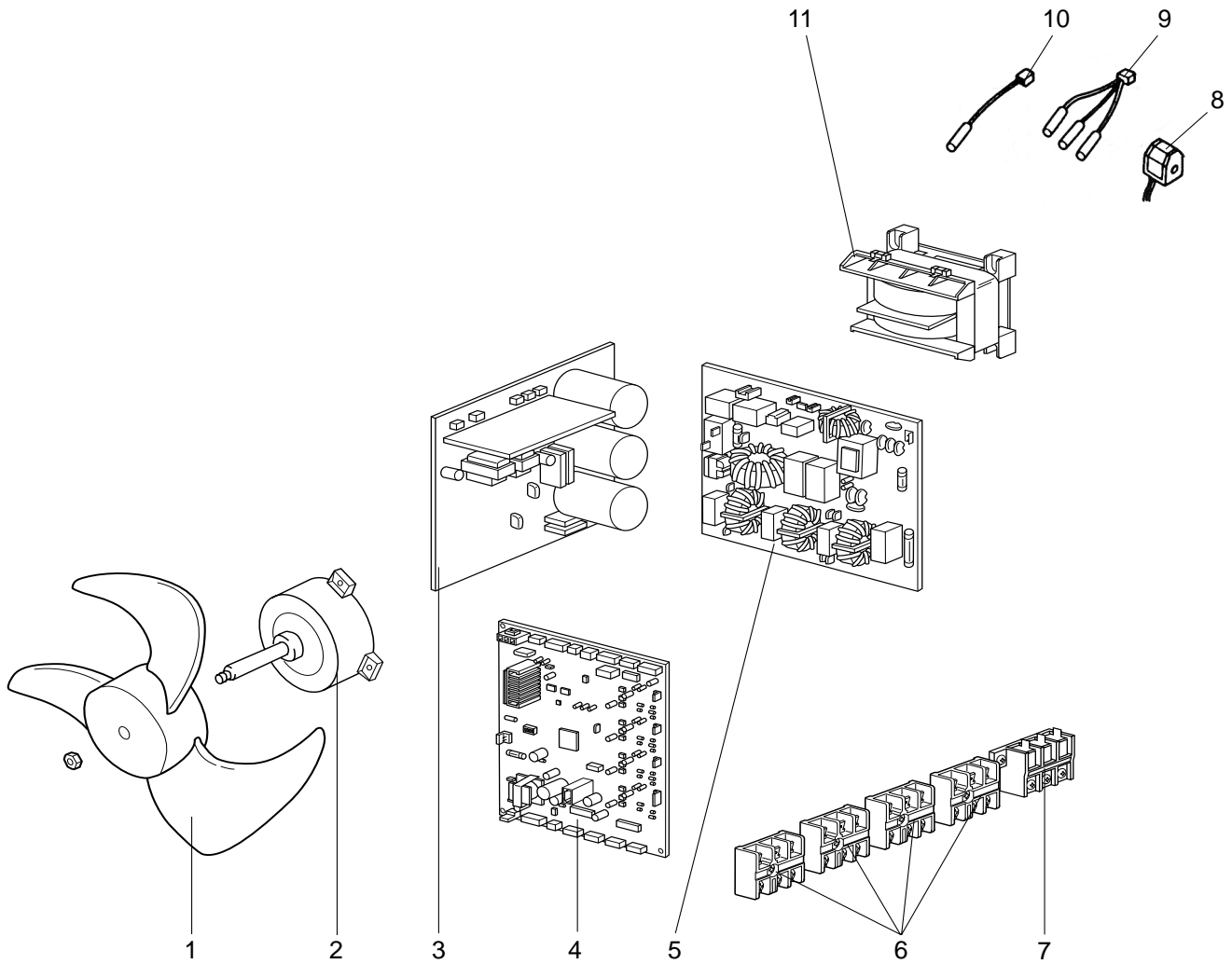

1-6. ACCESSORY

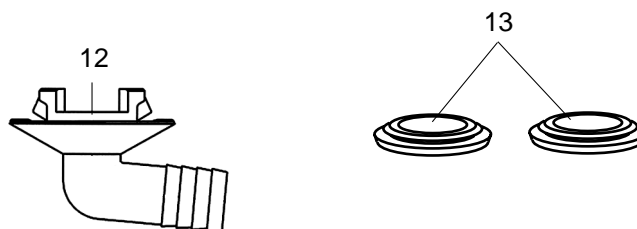

RoHS PARTS LIST (RoHS compliant)

MXZ-3B54VA MXZ-3B68VA MXZ-4B71VA

1-5. OUTDOOR UNIT FUNCTIONAL PARTS AND ELECTRICAL PARTS

Part numbers that are circled are not shown in the illustration.

No.	RoHS	Parts No.	Parts Name	Symbol in Wiring Diagram	Q'ty/unit			Remarks
					MXZ-			
					3B54VA- ^[E1]	3B68VA- ^[E1]	4B71VA- ^[E1]	
1	G	E12 851 501	PROPELLER		1	1	1	
2	G	E12 938 301	OUTDOOR FAN MOTOR	MF	1	1	1	RC0J60-□□
3	G	E12 F20 440	POWER BOARD		1	1	1	Including heat sink and RT64
4	G	E12 F20 450	ELECTRONIC CONTROL P.C. BOARD		1			
	G	E12 F21 450	ELECTRONIC CONTROL P.C. BOARD			1		
	G	E12 F22 450	ELECTRONIC CONTROL P.C. BOARD				1	
5	G	E12 F20 444	NOISE FILTER P.C. BOARD		1	1	1	
6	G	E12 C92 375	TERMINAL BLOCK	TB2~5	3	3	4	Indoor unit connecting
7	G	E12 D69 374	TERMINAL BLOCK	TB1	1	1	1	Power supply
8	G	E12 C18 490	R.V. COIL	21S4	1	1	1	
9	G	E12 938 308	THERMISTOR SET	RT61,62,68	1	1	1	DEFROST, DISCHARGE OUTDOOR HEAT EXCHANGER
10	G	E12 938 309	AMBIENT TEMPERATURE THERMISTOR	RT65	1	1	1	
11	G	E12 938 337	REACTOR	L	1	1	1	20A 600μH

1-6. ACCESSORY

No.	RoHS	Parts No.	Parts Name	Symbol in Wiring Diagram	Q'ty/unit			Remarks
					MXZ-			
					3B54VA- ^[E1]	3B68VA- ^[E1]	4B71VA- ^[E1]	
12	G	E12 817 704	DRAIN SOCKET		1	1	1	
13	G	E12 444 705	DRAIN CAP		2	2	2	

RoHS PARTS LIST (RoHS compliant)

MXZ-4B80VA MXZ-5B100VA

1-7. OUTDOOR UNIT STRUCTURAL PARTS AND FUNCTIONAL PARTS

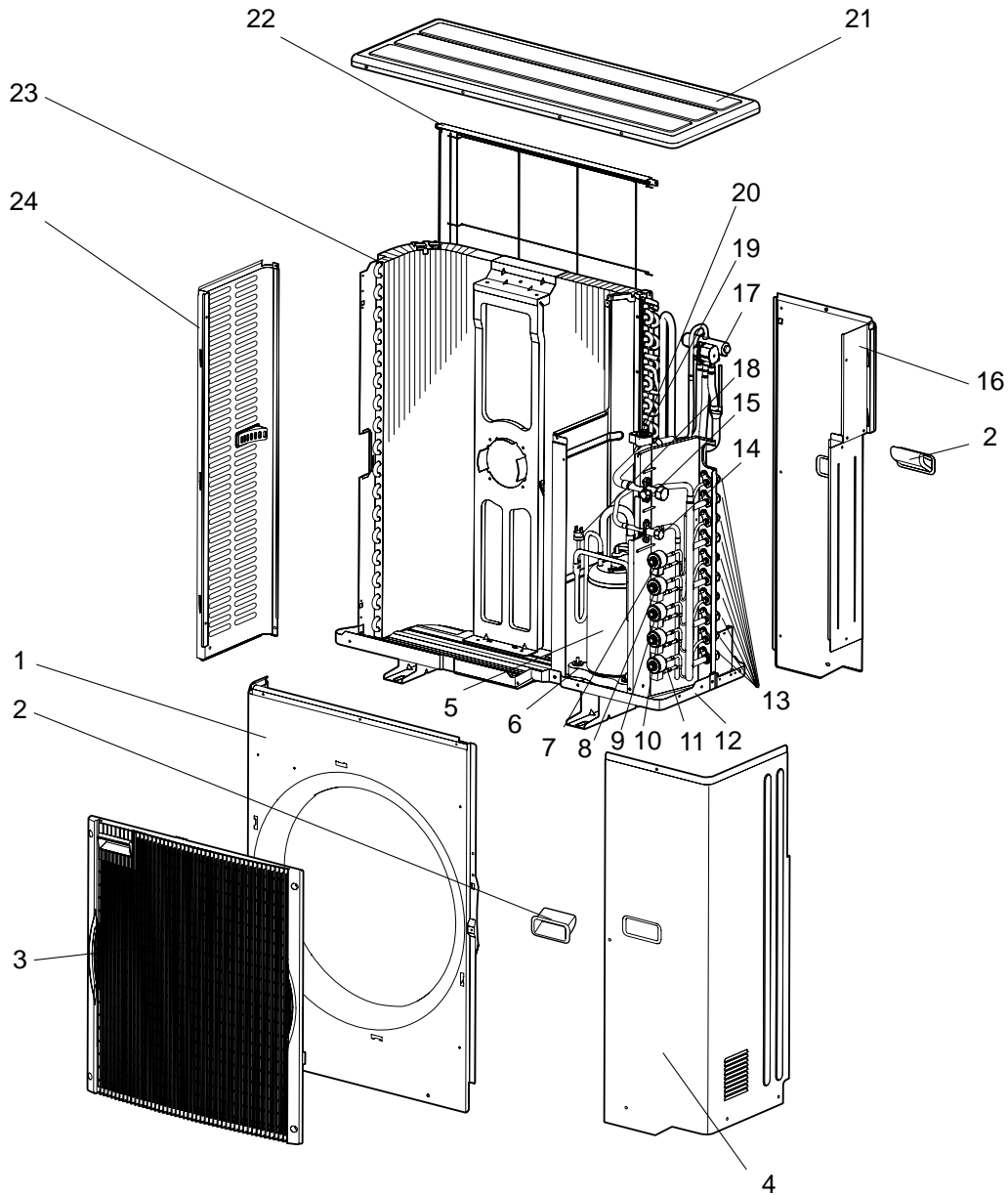

RoHS PARTS LIST (RoHS compliant)

MXZ-4B80VA MXZ-5B100VA

1-7. OUTDOOR UNIT STRUCTURAL PARTS AND FUNCTIONAL PARTS

Part numbers that are circled are not shown in the illustration.

No.	RoHS	Parts No.	Parts Name	Symbol in Wiring Diagram	Q'ty/unit		Remarks
					MXZ-4B80VA - E1	MXZ-5B100VA - E1	
1	G	M21 0A2 232	FRONT PANEL		1	1	
2	G	M21 0A2 027	HANDLE ASSEMBLY		2	2	
3	G	M21 L2V 010	GRILLE		1	1	
4	G	M21 0A2 245	SERVICE PANEL		1	1	
5	G	T92 505 801	COMPRESSOR	MC	1	1	TNB220FMCH
6	G	M21 L2V 505	COMPRESSOR RUBBER SET		3	3	3RUBBERS SET
7	G	M21 L2V 401	EXPANSION VALVE			1	E room
	G	M21 9T4 655	LEV COIL	LEV E		1	E room
8	G	M21 L2V 401	EXPANSION VALVE		1	1	D room
	G	M21 9T4 654	LEV COIL	LEV D	1	1	D room
9	G	M21 L2V 401	EXPANSION VALVE		1	1	C room
	G	M21 9T4 653	LEV COIL	LEV C	1	1	C room
10	G	M21 L2V 401	EXPANSION VALVE		1	1	B room
	G	M21 9T4 652	LEV COIL	LEV B	1	1	B room
11	G	M21 L2V 401	EXPANSION VALVE		1	1	A room
	G	M21 9T4 651	LEV COIL	LEV A	1	1	A room
12	G	M21 0A2 290	BASE ASSEMBLY		1	1	
13	G	M21 0A2 644	UNION		1	1	$\phi 12.7, \phi 9.52, \phi 6.35$ SET
14	G	M21 4N9 668	STOP VALVE (LIQUID) 3/8		1	1	$\phi 9.52$
15	G	M21 4N0 667	STOP VALVE (GAS) 5/8		1	1	$\phi 15.88$
16	G	M21 0A2 248	REAR PANEL		1	1	
17	G	M21 L2V 642	4-WAY VALVE		1	1	
18	G	M21 L2V 646	HIGH PRESSURE SWITCH	HPS	1	1	4.8 MPa (48.9 kg/cm ²)
19	G	M21 L2V 402	EXPANSION VALVE		1		F
	G	M21 0A2 402	EXPANSION VALVE			1	F
20	G	M21 9T6 651	LEV COIL	LEV F	1	1	
21	G	M21 L2V 297	TOP PANEL		1	1	
22	G	M21 0A2 523	REAR GUARD		1	1	
23	G	M21 0A3 630	OUTDOOR HEAT EXCHANGER		1		
	G	T2W 0A2 630	OUTDOOR HEAT EXCHANGER			1	
24	G	M21 L2V 249	SIDE PANEL		1	1	
25	G	M21 L2V 959	POWER RECEIVER		1	1	
26	G	M21 0A2 937	CAPILLARY TUBE		2	2	$\phi 3.0 \times \phi 2.0 \times 300$
27	G	M21 0A2 936	CAPILLARY TUBE		4	5	$\phi 4.0 \times \phi 2.8 \times 100$
28	G	M21 L2V 938	CAPILLARY TUBE		1	1	$\phi 2.5 \times \phi 0.6 \times 1000$
29	G	M21 L2V 656	OIL SEPARATOR		1	1	

RoHS PARTS LIST (RoHS compliant)

MXZ-4B80VA MXZ-5B100VA

1-8. OUTDOOR UNIT FUNCTIONAL PARTS AND ELECTRICAL PARTS

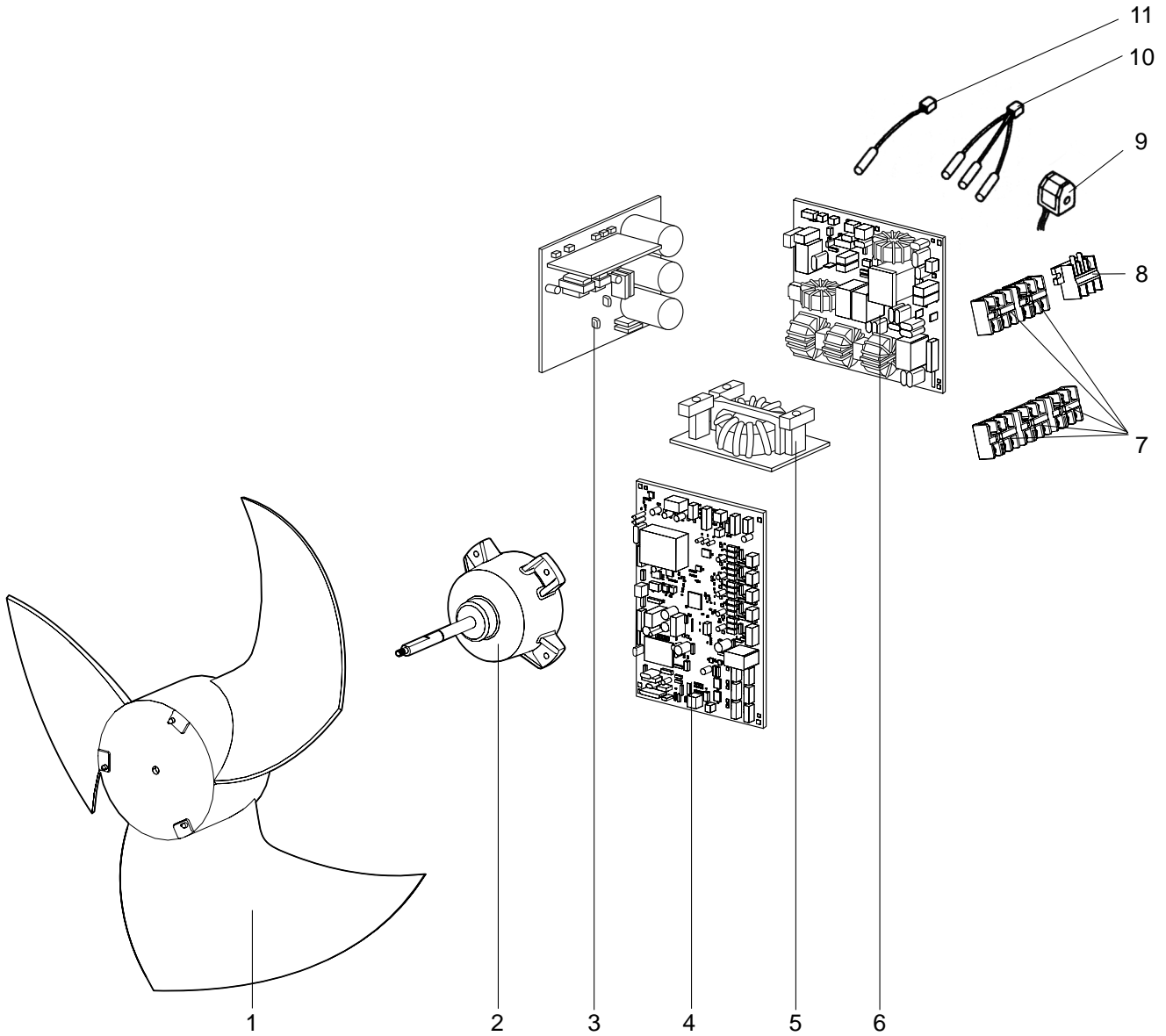

1-9. ACCESSORY

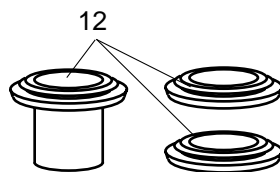

RoHS PARTS LIST (RoHS compliant)

MXZ-4B80VA MXZ-5B100VA

1-8. OUTDOOR UNIT FUNCTIONAL PARTS AND ELECTRICAL PARTS

No.	RoHS	Parts No.	Parts Name	Symbol in Wiring Diagram	Q'ty/unit		Remarks
					MXZ-4B80VA - E1	MXZ-5B100VA - E1	
1	G	M21 L2V 501	PROPELLER		1	1	PM8H60-□□
2	G	M21 L2V 301	OUTDOOR FAN MOTOR	MF	1	1	
3	G	M21 9T4 440	POWER BOARD		1	1	Including heat sink and RT64
4	G	T2W 9T5 451	ELECTRONIC CONTROL P.C. BOARD		1		
	G	T2W 9T4 451	ELECTRONIC CONTROL P.C. BOARD			1	
5	G	M21 L2V 337	REACTOR	L	1	1	20A 600μH
6	G	M21 9T5 424	NOISE FILTER P.C. BOARD		1	1	
7	G	T2W 0A2 376	TERMINAL BLOCK	TB2~6	4	5	Indoor unit connecting
8	G	T2W 9T4 377	TERMINAL BLOCK	TB1	1	1	Power supply
9	G	T2W L2V 398	R.V. COIL	21S4	1	1	
10	G	M21 L2V 308	THERMISTOR SET	RT61,62,68	1	1	DEFROST, DISCHARGE, OUTDOOR HEAT EXCHANGER
11	G	M21 0A2 309	AMBIENT TEMPERATURE THERMISTOR	RT65	1	1	

1-9. ACCESSORY

No.	RoHS	Parts No.	Parts Name	Symbol in Wiring Diagram	Q'ty/unit		Remarks
					MXZ-4B80VA - E1	MXZ-5B100VA - E1	
12	G	T2W L2V 704	DRAIN SOCKET ASSEMBLY		1	1	DRAIN SOCKET ×1 DRAIN CAP ×2

2

OPTIONAL PARTS

2-1. DIFFERENT-DIAMETER PIPE

MXZ-3B54VA MXZ-3B68VA MXZ-4B71VA MXZ-4B80VA MXZ-5B100VA	Model name	Connected pipes diameter	Diameter A	Diameter B	Length C
For different-diameter pipes	MAC-A454JP	φ9.52 — φ12.7 (3/8) (1/2)	φ9.52 (3/8)	φ12.7 (1/2)	69
	MAC-A455JP	φ12.7 — φ9.52 (1/2) (3/8)	φ12.7 (1/2)	φ9.52 (3/8)	65
	MAC-A456JP	φ12.7 — φ15.88 (1/2) (5/8)	φ12.7 (1/2)	φ15.88 (5/8)	66.5
	PAC-493PI	φ6.35 — φ9.52 (1/4) (3/8)	φ6.35 (1/4)	φ9.52 (3/8)	60.5
	PAC-SG76RJ-E	φ9.52 — φ15.88 (3/8) (5/8)	φ9.52 (3/8)	φ15.88 (5/8)	101.5

Unit: mm (inch)

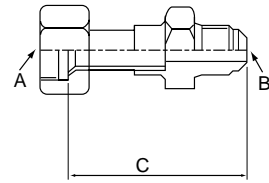

2-2. OUTLET GUIDE

Changes air discharge direction.

Applied unit	Model name	Model code
MXZ-2B30VA MXZ-2B40VA MXZ-2B52VA MXZ-3B54VA MXZ-3B68VA MXZ-4B71VA	MAC-889SG	506-889
MXZ-4B80VA MXZ-5B100VA	MAC-856SG	51H-856

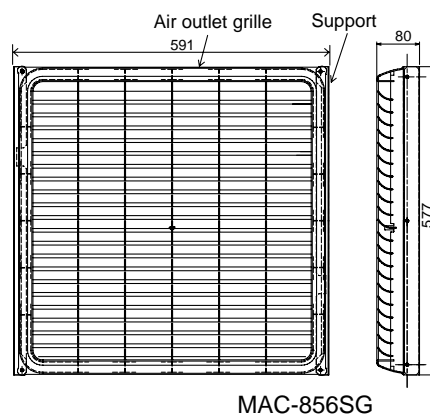
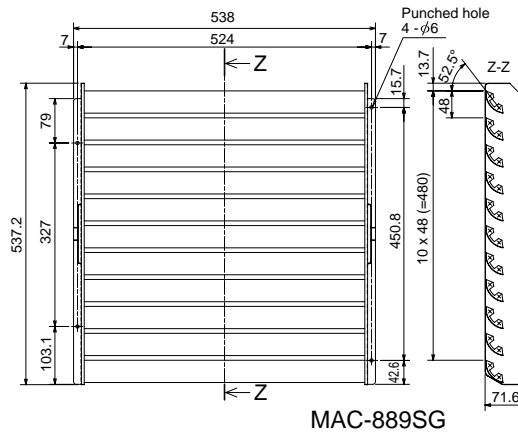



HEAD OFFICE: TOKYO BLDG., 2-7-3, MARUNOUCHI, CHIYODA-KU, TOKYO 100-8310, JAPAN

© Copyright 2009 MITSUBISHI ELECTRIC ENGINEERING CO.,LTD

Distributed in Jan. 2010. No.OBB554 REVISED EDITION-C 5

Distributed in Dec. 2009. No.OBB554 REVISED EDITION-B 6

Distributed in Nov. 2009. No.OBB554 REVISED EDITION-A 6

Distributed in Aug. 2009. No.OBB554 6

Made in Japan

New publication, effective Jan. 2010
Specifications subject to change without notice.