

Revision D:

- MXZ-6C122VA- **E1** has been added.

Please void OBB584 REVISED EDITION-C.

OUTDOOR UNIT PARTS CATALOG



**No. OBB584
REVISED EDITION-D**

Models

MXZ-2C30VA - E1

MXZ-2C40VA - E1

MXZ-2C52VA - E1

MXZ-3C54VA - E1

MXZ-3C68VA - E1

MXZ-4C71VA - E1

MXZ-4C80VA - E1

MXZ-4C80VA2 - E1

MXZ-5C100VA - E1

MXZ-5C100VA2 - E1

MXZ-6C120VA - E1

MXZ-6C120VA - E2

MXZ-6C122VA - E1

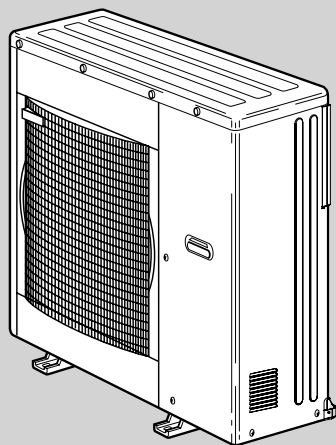

**MXZ-4C80VA
MXZ-5C100VA**

CONTENTS

1. RoHS PARTS LIST..... 2
2. OPTIONAL PARTS..... BACK COVER

SERVICE MANUAL (OBH584)

NOTE:

RoHS compliant products have <G> mark on the spec name plate.



Revision A:

- MXZ-2C30VA- [E1], MXZ-2C40VA- [E1], and MXZ-2C52VA- [E1] have been added.

Revision B:

- MXZ-6C120VA- [E2] has been added.

Revision C:

- MXZ-4C80VA2- [E1] and MXZ-5C100VA2- [E1] have been added.

Revision D:

- MXZ-6C122VA- [E1] has been added.

1

RoHS PARTS LIST

MXZ-2C30VA MXZ-2C40VA MXZ-2C52VA

1-1. OUTDOOR UNIT STRUCTURAL PARTS AND FUNCTIONAL PARTS

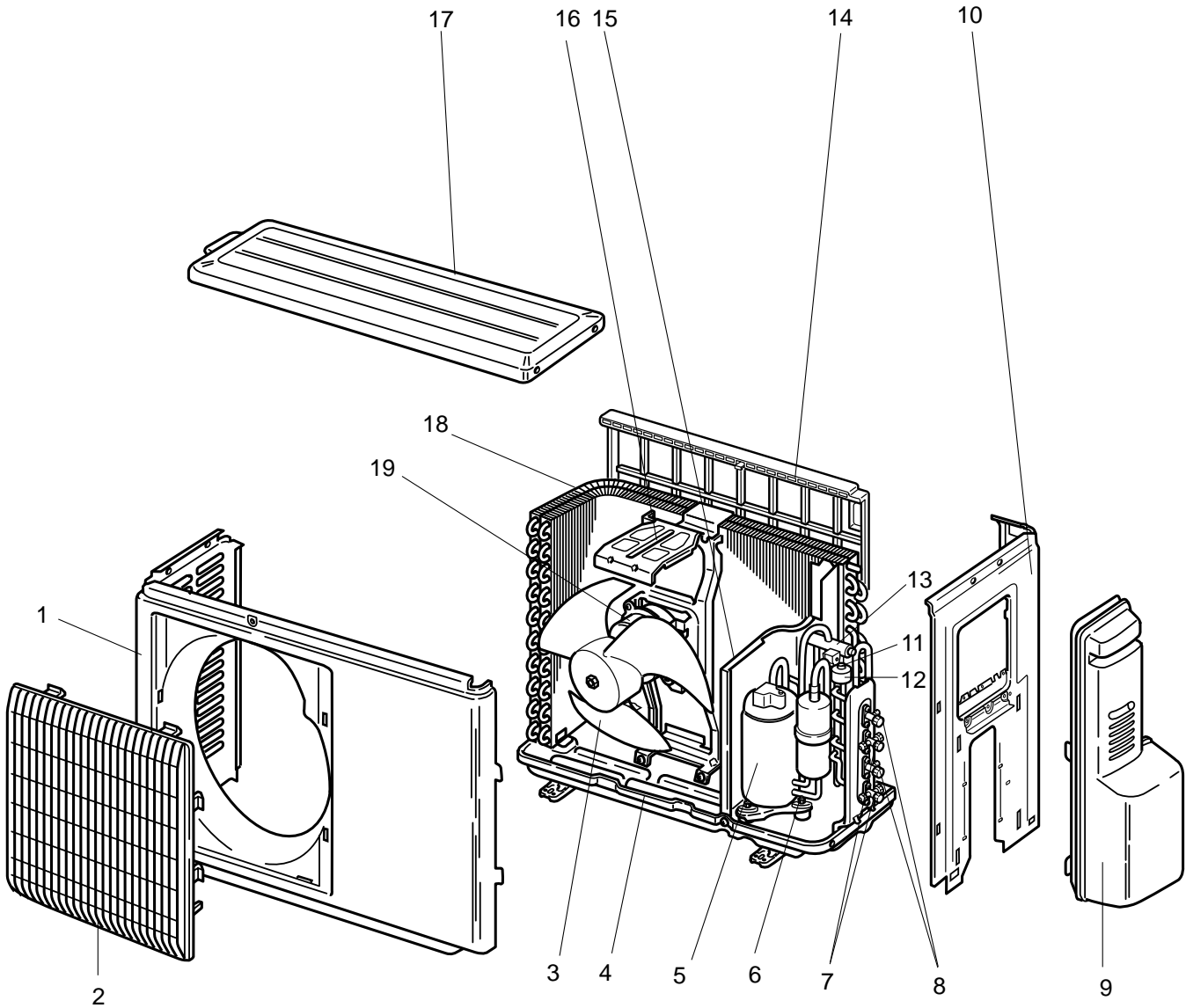

RoHS PARTS LIST (RoHS compliant)

MXZ-2C30VA MXZ-2C40VA MXZ-2C52VA

1-1. OUTDOOR UNIT STRUCTURAL PARTS AND FUNCTIONAL PARTS

Part numbers that are circled are not shown in the illustration.

No.	ROHS	Part No.	Part Name	Symbol in Wiring Diagram	Q'ty/unit			Remarks
					MXZ-			
					2C30VA- [E1]	2C40VA- [E1]	2C52VA- [E1]	
1	G	E12 927 232	CABINET		1		1	
	G	E12 A89 232	CABINET			1		
2	G	E12 927 521	GRILLE		1	1	1	
3	G	E12 927 501	PROPELLER		1	1	1	
4	G	E12 A45 290	BASE		1		1	
	G	E12 F24 290	BASE			1		
5	G	E12 F24 900	COMPRESSOR	MC		1		KNB092FFDHC
	G	E12 E05 900	COMPRESSOR	MC			1	SNB130FGBHT
	G	E12 D75 900	COMPRESSOR	MC	1			KNB073FGDHC
6	G	E12 065 506	COMPRESSOR RUBBER SET		3			3RUBBERS/SET
	G	E12 C34 506	COMPRESSOR RUBBER SET			3	3	3RUBBERS/SET
7	G	E12 927 661	STOP VALVE (GAS)		2	2	2	Ø9.52
8	G	E12 927 662	STOP VALVE (LIQUID)		2	2	2	Ø6.35
9	G	E12 A47 245	SERVICE PANEL		1	1	1	
10	G	E12 A47 233	BACK PANEL		1	1	1	
11	G	E12 735 640	EXPANSION VALVE		1	1	1	ROOM B
12	G	E12 F25 493	EXPANSION VALVE COIL	LEV B	1	1	1	
13	G	E12 A47 961	4-WAY VALVE				1	
	G	E12 927 961	4-WAY VALVE		1	1		
14	G	E12 G06 523	CONDENSER NET				1	
	G	E12 G04 523	CONDENSER NET		1			
	G	E12 G05 523	CONDENSER NET			1		
15	G	E12 G05 293	SEPARATOR			1	1	
	G	E12 G04 293	SEPARATOR		1			
16	G	E12 929 515	MOTOR SUPPORT			1	1	
	G	E12 927 515	MOTOR SUPPORT		1			
17	G	E12 927 297	TOP PANEL		1	1	1	
18	G	E12 G04 630	OUTDOOR HEAT EXCHANGER		1			
	G	E12 G05 630	OUTDOOR HEAT EXCHANGER			1		
	G	E12 G06 630	OUTDOOR HEAT EXCHANGER				1	
19	G	E12 A47 301	OUTDOOR FAN MOTOR	MF	1	1	1	RC0J50- □□
20	G	E12 339 936	CAPILLARY TUBE			4	4	Ø3.0 × Ø1.4 × 600
	G	E12 838 936	CAPILLARY TUBE		2	2	2	Ø3.0 × Ø2.0 × 200
21	G	E12 735 640	EXPANSION VALVE		1	1	1	ROOM A
22	G	E12 F24 493	EXPANSION VALVE COIL	LEV A	1	1	1	

RoHS PARTS LIST (RoHS compliant)

MXZ-2C30VA MXZ-2C40VA MXZ-2C52VA

1-2. OUTDOOR UNIT ELECTRICAL PARTS

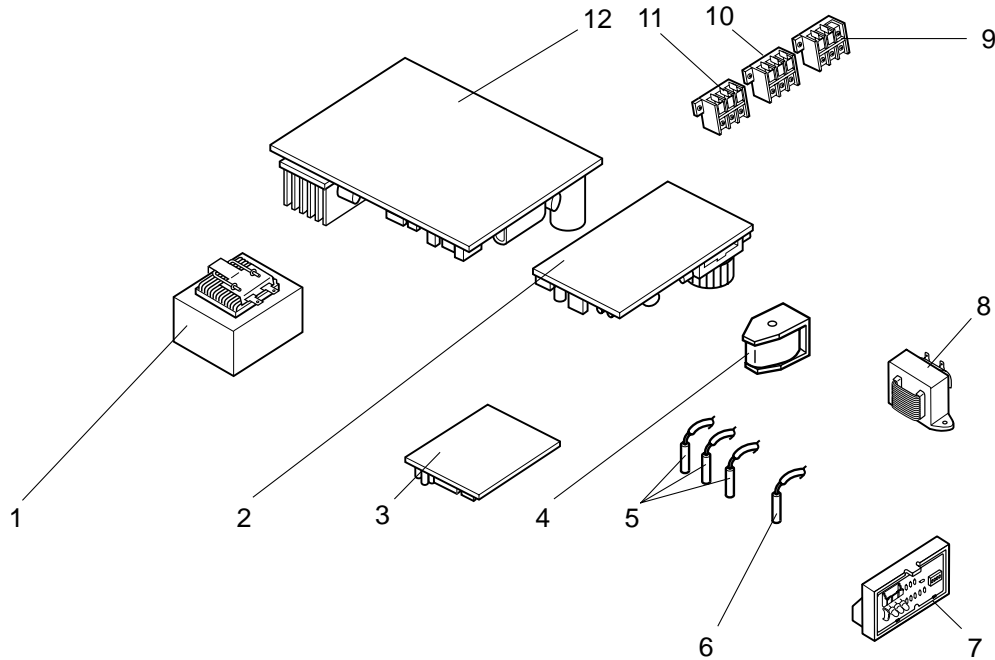

Part numbers that are circled are not shown in the illustration.

No.	RoHS	Part No.	Part Name	Symbol in Wiring Diagram	Q'ty/unit			Remarks
					MXZ-2C30VA- E1	MXZ-2C40VA- E1	MXZ-2C52VA- E1	
1	G	E12 G11 337	REACTOR	L64	1	1	1	10A 23μH
2	G	E12 F23 440	POWER P.C. BOARD		1	1	1	
3	G	E12 F23 454	INTERFACE P.C. BOARD		1	1	1	
4	G	E12 A47 490	R.V. COIL	21S4	1	1	1	
5	G	E12 A47 308	THERMISTOR SET	RT61,62,68	1	1	1	DEFROST, DISCHARGE OUTDOOR HEAT EXCHANGER
6	G	E12 A47 309	AMBIENT TEMPERATURE THERMISTOR	RT65	1	1	1	
7	G	E12 A47 329	DISPLAY P.C. BOARD		1	1	1	
8	G	E12 A47 337	REACTOR	L65	1	1	1	2A 25μH
9	G	E12 F24 374	TERMINAL BLOCK	TB1	1	1	1	Power supply
10	G	E12 935 374	TERMINAL BLOCK	TB3	1	1	1	Indoor unit connecting
	G	E12 935 374	TERMINAL BLOCK	TB2	1	1	1	Indoor unit connecting
12	G	E12 G04 451	INVERTER P.C. BOARD		1			Including heat sink and RT64
	G	E12 G05 451	INVERTER P.C. BOARD			1		Including heat sink and RT64
	G	E12 G06 451	INVERTER P.C. BOARD				1	Including heat sink and RT64

RoHS PARTS LIST (RoHS compliant)

MXZ-2C30VA MXZ-2C40VA MXZ-2C52VA
1-3. DRAIN SOCKET

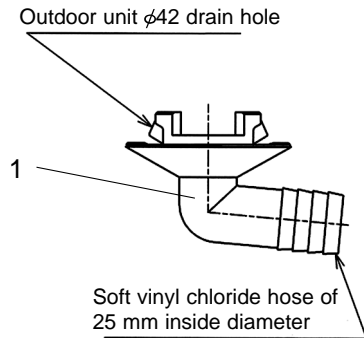

No.	RoHS	Parts No.	Parts Name	Symbol in Wiring Diagram	Q'ty/unit			Remarks
					MXZ-			
					2C30VA-[E1]	2C40VA-[E1]	2C52VA-[E1]	
1	G	E12 838 704	DRAIN SOCKET		1	1	1	

RoHS PARTS LIST (RoHS compliant)

MXZ-3C54VA MXZ-3C68VA MXZ-4C71VA

1-4. OUTDOOR UNIT STRUCTURAL PARTS AND FUNCTIONAL PARTS

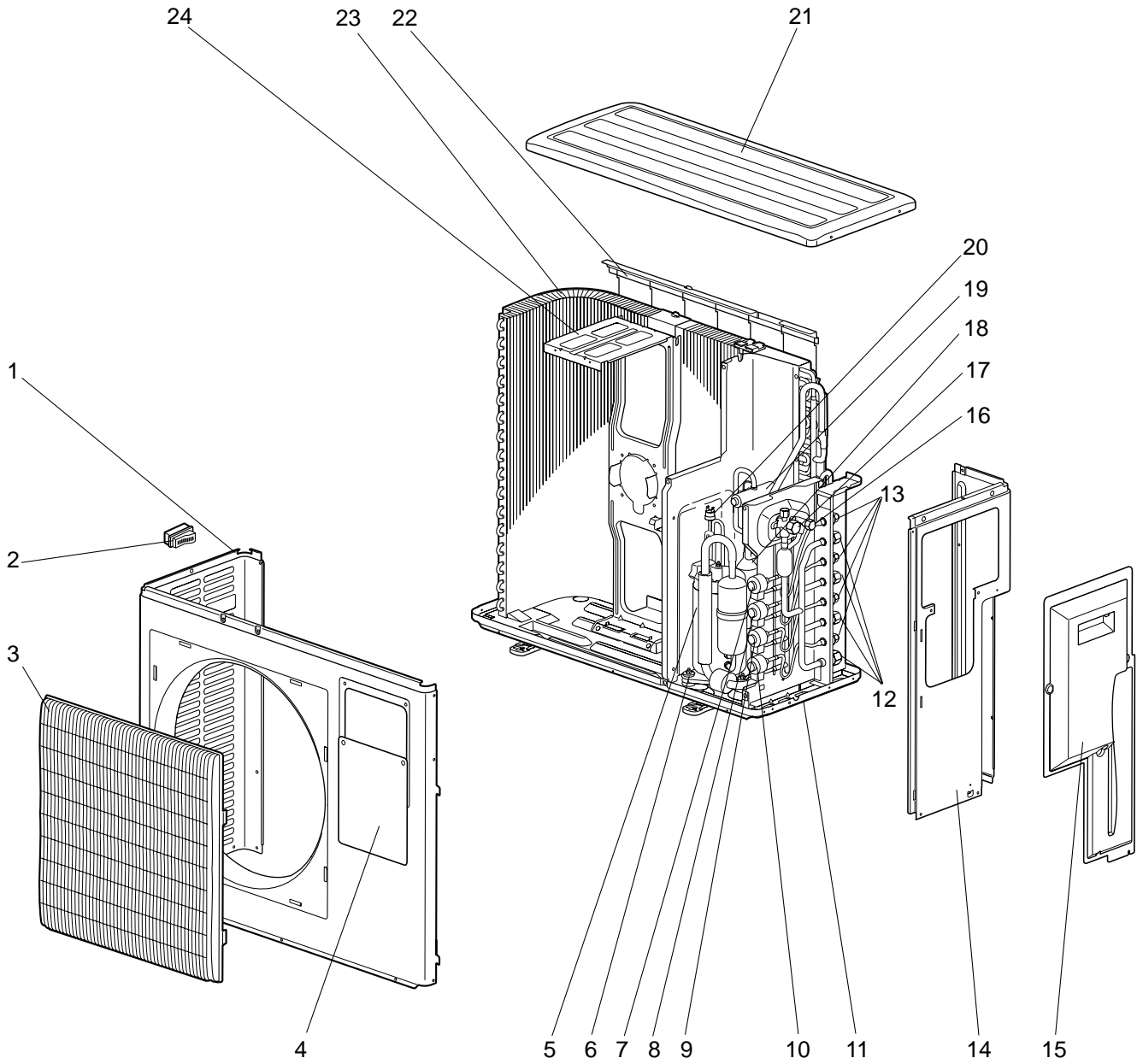

RoHS PARTS LIST (RoHS compliant)

MXZ-3C54VA MXZ-3C68VA MXZ-4C71VA

1-4. OUTDOOR UNIT STRUCTURAL PARTS AND FUNCTIONAL PARTS

Part numbers that are circled are not shown in the illustration.

No.	RoHS	Parts No.	Parts Name	Symbol in Wiring Diagram	Q'ty/unit			Remarks
					MXZ-			
					3C54VA-[E1]	3C68VA-[E1]	4C71VA-[E1]	
1	G	E12 D36 232	CABINET		1	1	1	
2	G	E12 817 009	HANDLE		1	1	1	
3	G	E12 939 521	GRILLE		1	1	1	
4	G	E12 D36 246	SUB PANEL		1	1	1	
5	G	E12 F22 900	COMPRESSOR	MC		1	1	SNB172FEGH1T
	G	E12 F10 900	COMPRESSOR	MC	1			SNB130FGBH1T
6	G	E12 C34 506	COMPRESSOR RUBBER SET		3	3	3	3RUBBERS SET
7	G	E12 851 640	EXPANSION VALVE				1	D room
	G	E12 F21 493	LEV COIL	LEV D			1	D room
8	G	E12 851 640	EXPANSION VALVE		1	1	1	C room
	G	E12 F20 493	LEV COIL	LEV C	1	1	1	C room
9	G	E12 851 640	EXPANSION VALVE		1	1	1	B room
	G	E12 F54 493	LEV COIL	LEV B	1	1	1	B room
10	G	E12 851 640	EXPANSION VALVE		1	1	1	A room
	G	E12 F15 493	LEV COIL	LEV A, E	2	2	2	A, room, LEV E
11	G	E12 939 290	BASE		1	1	1	
12	G	E12 D36 666	UNION(GAS)		3	3	3	Ø9.52
	G	E12 D37 666	UNION(GAS)				1	Ø12.7
13	G	E12 D36 667	UNION(LIQUID)		3	3	4	Ø6.35
14	G	E12 939 233	BACK PANEL		1	1	1	
15	G	E12 D36 245	SERVICE PANEL		1	1	1	
16	G	E12 D36 662	STOP VALVE (LIQUID) 3/8		1	1	1	Ø9.52
17	G	E12 D36 661	STOP VALVE (GAS) 5/8		1	1	1	Ø15.88
18	G	E12 D36 299	OIL SEPARATOR		1	1	1	
19	G	E12 C18 961	4-WAY VALVE		1	1	1	
20	G	E12 853 646	HIGH PRESSURE SWITCH	HPS		1	1	
21	G	E12 819 297	TOP PANEL		1	1	1	
22	G	E12 939 523	REAR GUARD		1	1	1	
23	G	E12 939 630	OUTDOOR HEAT EXCHANGER		1	1	1	
24	G	E12 G07 515	MOTOR SUPPORT		1	1	1	
25	G	E12 938 937	CAPILLARY TUBE		8	8	8	Ø3.6 × Ø2.4 × 500
26	G	E12 939 936	CAPILLARY TUBE		3	3	4	Ø4.0 × Ø2.8 × 100
27	G	E12 938 936	CAPILLARY TUBE		1	1	1	Ø2.5 × Ø0.6 × 1000
28	G	E12 C18 959	POWER RECEIVER		1	1	1	
29	G	E12 853 640	EXPANSION VALVE		1	1	1	E

RoHS PARTS LIST (RoHS compliant)

MXZ-3C54VA MXZ-3C68VA MXZ-4C71VA

1-5. OUTDOOR UNIT FUNCTIONAL PARTS AND ELECTRICAL PARTS

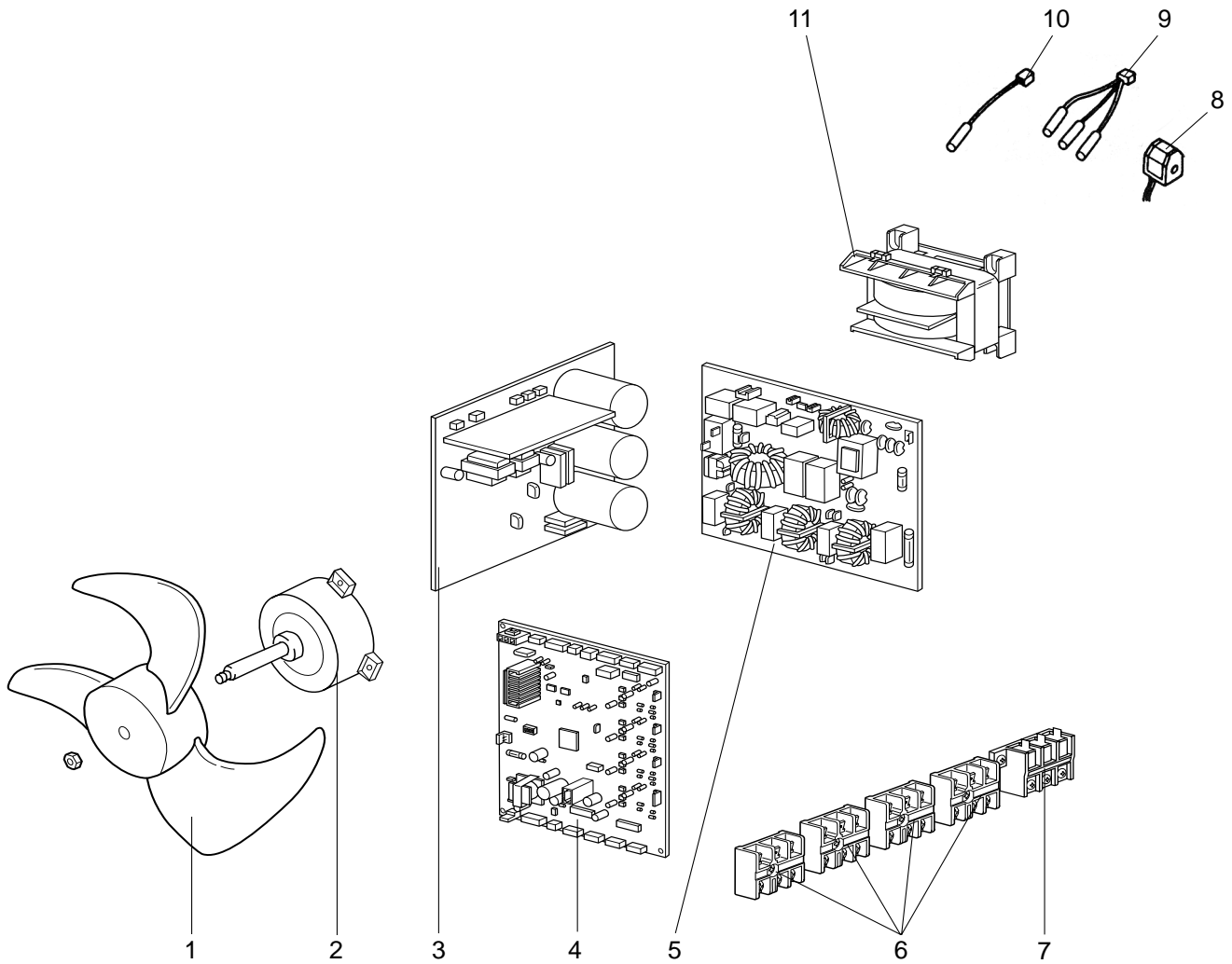

1-6. ACCESSORY

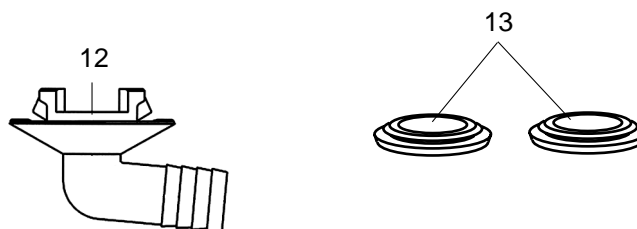

RoHS PARTS LIST (RoHS compliant)

MXZ-3C54VA MXZ-3C68VA MXZ-4C71VA

1-5. OUTDOOR UNIT FUNCTIONAL PARTS AND ELECTRICAL PARTS

Part numbers that are circled are not shown in the illustration.

No.	RoHS	Parts No.	Parts Name	Symbol in Wiring Diagram	Q'ty/unit			Remarks
					MXZ-			
					3C54VA- ^[E1]	3C68VA- ^[E1]	4C71VA- ^[E1]	
1	G	E12 851 501	PROPELLER		1	1	1	
2	G	E12 G07 301	OUTDOOR FAN MOTOR	MF	1	1	1	RC0J60- □□
3	G	E12 F20 440	POWER BOARD		1	1	1	Including heat sink and RT64
4	G	E12 G07 450	ELECTRONIC CONTROL P.C. BOARD		1			
	G	E12 G08 450	ELECTRONIC CONTROL P.C. BOARD			1		
	G	E12 G09 450	ELECTRONIC CONTROL P.C. BOARD				1	
5	G	E12 F20 444	NOISE FILTER P.C. BOARD		1	1	1	
6	G	E12 C92 375	TERMINAL BLOCK	TB2~5	3	3	4	Indoor unit connecting
7	G	E12 D69 374	TERMINAL BLOCK	TB1	1	1	1	Power supply
8	G	E12 C18 490	R.V. COIL	21S4	1	1	1	
9	G	E12 938 308	THERMISTOR SET	RT61,62,68	1	1	1	DEFROST, DISCHARGE OUTDOOR HEAT EXCHANGER
10	G	E12 938 309	AMBIENT TEMPERATURE THERMISTOR	RT65	1	1	1	
11	G	E12 938 337	REACTOR	L	1	1	1	20A 600μH

1-6. ACCESSORY

No.	RoHS	Parts No.	Parts Name	Symbol in Wiring Diagram	Q'ty/unit			Remarks
					MXZ-			
					3C54VA- ^[E1]	3C68VA- ^[E1]	4C71VA- ^[E1]	
12	G	E12 817 704	DRAIN SOCKET		1	1	1	
13	G	E12 444 705	DRAIN CAP		2	2	2	

RoHS PARTS LIST (RoHS compliant)

MXZ-4C80VA MXZ-5C100VA

1-7. OUTDOOR UNIT STRUCTURAL PARTS AND FUNCTIONAL PARTS

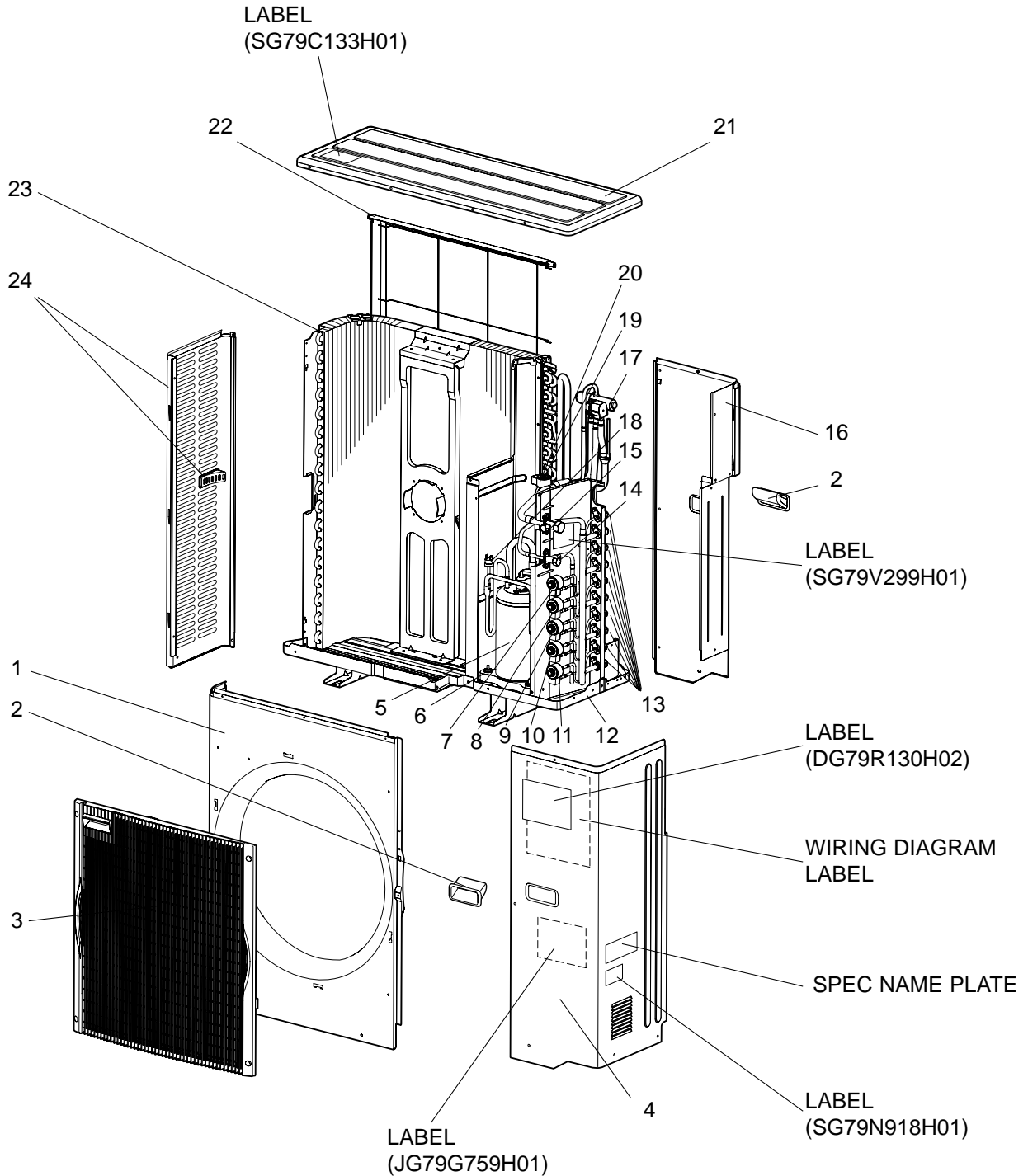

RoHS PARTS LIST (RoHS compliant)

MXZ-4C80VA MXZ-5C100VA

1-7. OUTDOOR UNIT STRUCTURAL PARTS AND FUNCTIONAL PARTS

Part numbers that are circled are not shown in the illustration.

No.	RoHS	Parts No.	Parts Name	Symbol in Wiring Diagram	Q'ty/unit		Remarks
					MXZ-		
					4C80VA - [E1]	5C100VA - [E1]	
1	G	M21 EA2 232	FRONT PANEL		1	1	
2	G	M21 0A2 027	HANDLE ASSEMBLY		2	2	
3	G	M21 L2V 010	GRILLE		1	1	
4	G	M21 EA1 245	SERVICE PANEL		1	1	Without LABEL
5	G	T92 505 801	COMPRESSOR	MC	1	1	TNB220FMCH
6	G	M21 L2V 505	COMPRESSOR RUBBER SET		3	3	3RUBBERS SET
7	G	M21 L2V 401	EXPANSION VALVE			1	E room
	G	M21 9T4 655	LEV COIL	LEV E		1	E room
8	G	M21 L2V 401	EXPANSION VALVE		1	1	D room
	G	M21 9T4 654	LEV COIL	LEV D	1	1	D room
9	G	M21 L2V 401	EXPANSION VALVE		1	1	C room
	G	M21 9T4 653	LEV COIL	LEV C	1	1	C room
10	G	M21 L2V 401	EXPANSION VALVE		1	1	B room
	G	M21 9T4 652	LEV COIL	LEV B	1	1	B room
11	G	M21 L2V 401	EXPANSION VALVE		1	1	A room
	G	M21 9T4 651	LEV COIL	LEV A	1	1	A room
12	G	M21 EA0 290	BASE ASSEMBLY		1	1	
13	G	M21 0A2 644	UNION		1	1	Ø12.7, Ø9.52, Ø6.35 SET
14	G	M21 4N9 668	STOP VALVE (LIQUID) 3/8		1	1	Ø9.52
15	G	M21 4N0 667	STOP VALVE (GAS) 5/8		1	1	Ø15.88
16	G	M21 EA0 248	REAR PANEL		1	1	
17	G	M21 L2V 642	4-WAY VALVE		1	1	
18	G	M21 L2V 646	HIGH PRESSURE SWITCH	HPS	1	1	4.8 MPa (48.9 kg/cm ²)
19	G	M21 L2V 402	EXPANSION VALVE		1		F
	G	M21 0A2 402	EXPANSION VALVE			1	F
20	G	M21 9T6 651	LEV COIL	LEV F	1	1	
21	G	M21 EA1 297	TOP PANEL		1	1	Without LABEL
22	G	M21 0A2 523	REAR GUARD		1	1	
23	G	M21 0A3 630	OUTDOOR HEAT EXCHANGER		1		
	G	T2W 0A2 630	OUTDOOR HEAT EXCHANGER			1	
24	G	M21 EA0 249	SIDE PANEL		1	1	Including handle
25	G	M21 EAA 959	POWER RECEIVER		1	1	
26	G	M21 0A2 937	CAPILLARY TUBE		2	2	Ø3.0 × Ø2.0 × 300
27	G	M21 0A2 936	CAPILLARY TUBE		4	5	Ø4.0 × Ø2.8 × 100
28	G	M21 L2V 938	CAPILLARY TUBE		1	1	Ø2.5 × Ø0.6 × 1000
29	G	M21 L2V 656	OIL SEPARATOR		1	1	

RoHS PARTS LIST (RoHS compliant)

MXZ-4C80VA MXZ-5C100VA

1-8. OUTDOOR UNIT FUNCTIONAL PARTS AND ELECTRICAL PARTS

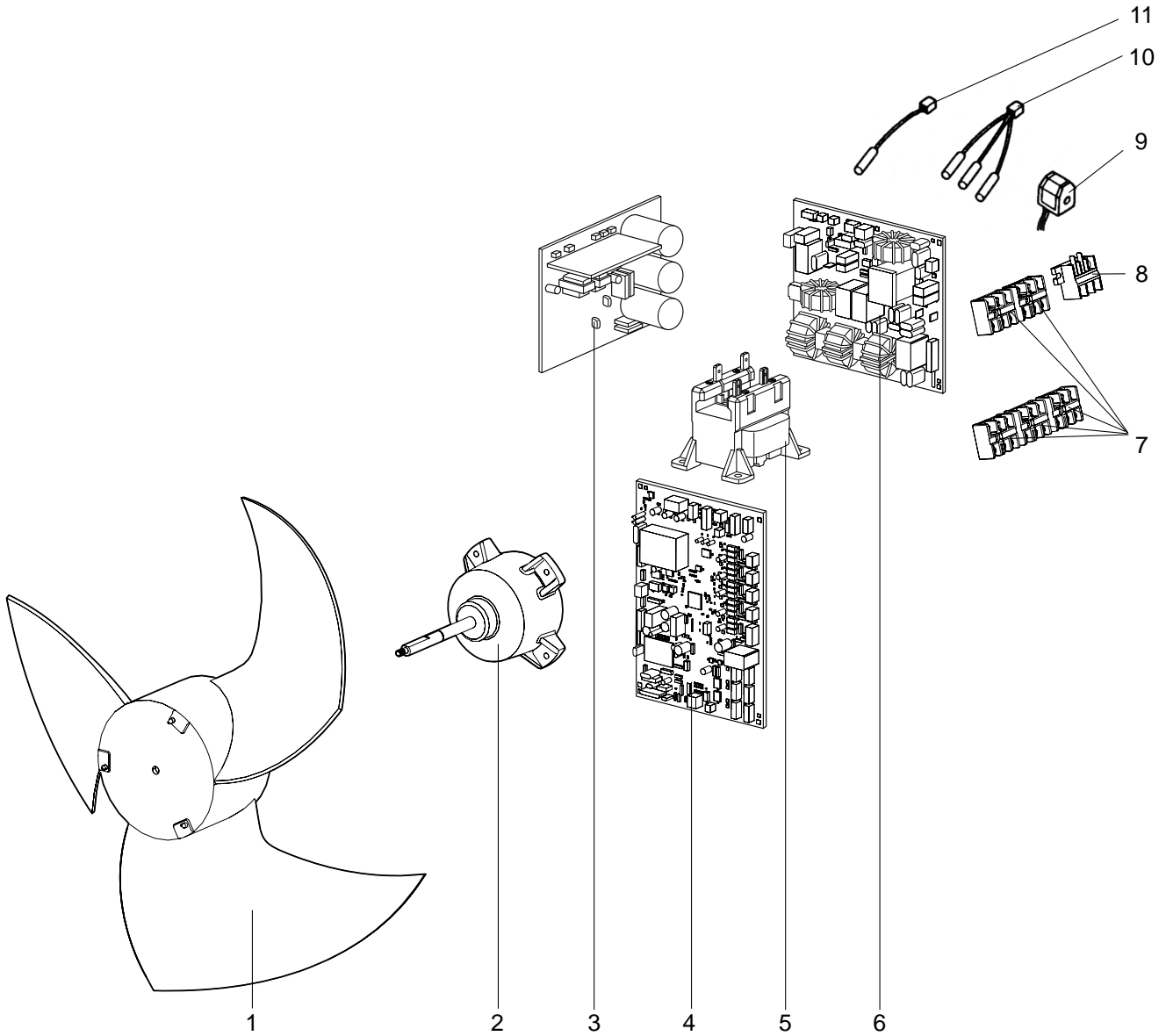

1-9. ACCESSORY

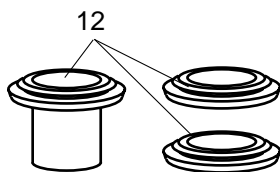

RoHS PARTS LIST (RoHS compliant)

MXZ-4C80VA MXZ-5C100VA

1-8. OUTDOOR UNIT FUNCTIONAL PARTS AND ELECTRICAL PARTS

No.	RoHS	Parts No.	Parts Name	Symbol in Wiring Diagram	Q'ty/unit		Remarks
					MXZ-		
					4C80VA - E1	5C100VA - E1	
1	G	M21 L2V 501	PROPELLER		1	1	
2	G	T2W 3K5 301	OUTDOOR FAN MOTOR	MF	1	1	RC0J60- □□
3	G	M21 9T4 440	POWER BOARD		1	1	Including heat sink and RT64
4	G	T2W 3K8 451	ELECTRONIC CONTROL P.C. BOARD		1		
	G	T2W 3K7 451	ELECTRONIC CONTROL P.C. BOARD			1	
5	G	M21 9T7 337	REACTOR	L	1	1	20A 600μH
6	G	M21 9T5 424	NOISE FILTER P.C. BOARD		1	1	
7	G	T2W 0A2 376	TERMINAL BLOCK	TB2~6	4	5	Indoor unit connecting
8	G	T2W 9T4 377	TERMINAL BLOCK	TB1	1	1	Power supply
9	G	T2W L2V 398	R.V. COIL	21S4	1	1	
10	G	M21 L2V 308	THERMISTOR SET	RT61,62,68	1	1	DEFROST, DISCHARGE, OUTDOOR HEAT EXCHANGER
11	G	M21 0A2 309	AMBIENT TEMPERATURE THERMISTOR	RT65	1	1	

1-9. ACCESSORY

No.	RoHS	Parts No.	Parts Name	Symbol in Wiring Diagram	Q'ty/unit		Remarks
					MXZ-		
					4C80VA - E1	5C100VA - E1	
12	G	T2W L2V 704	DRAIN SOCKET ASSEMBLY		1	1	DRAIN SOCKET ×1 DRAIN CAP ×2

RoHS PARTS LIST (RoHS compliant)

MXZ-4C80VA2 MXZ-5C100VA2

1-10. OUTDOOR UNIT STRUCTURAL PARTS AND FUNCTIONAL PARTS

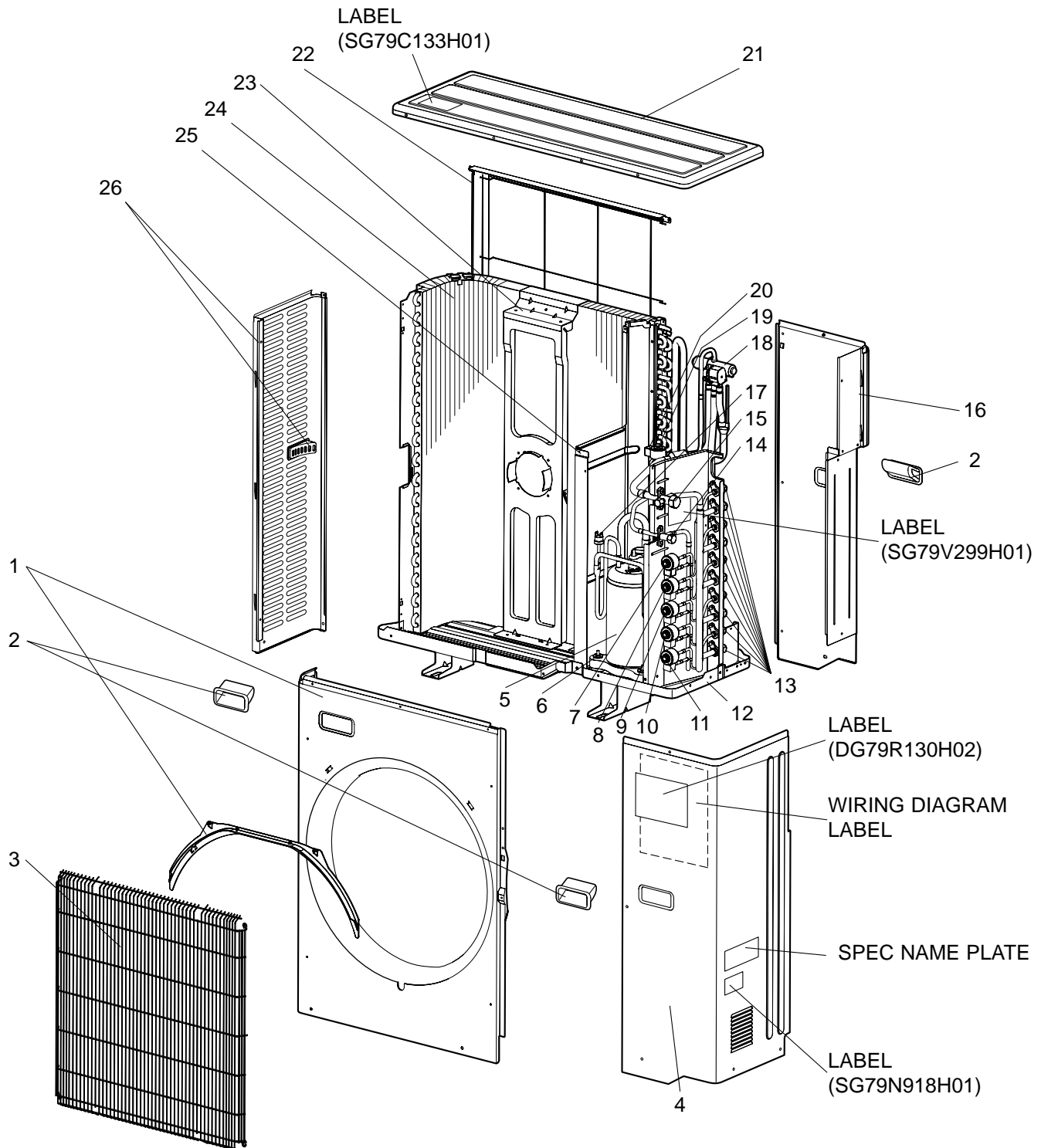

RoHS PARTS LIST (RoHS compliant)

MXZ-4C80VA2 MXZ-5C100VA2

1-10. OUTDOOR UNIT STRUCTURAL PARTS AND FUNCTIONAL PARTS

Part numbers that are circled are not shown in the illustration.

No.	ROHS	Parts No.	Parts Name	Symbol In Wiring Diagram	Q'ty/unit		Remarks
					MXZ-		
					4C80VA2- [E1]	5C100VA2- [E1]	
1	G	M21 EAA 232	FRONT PANEL		1	1	Including grille roof
2	G	M21 0A2 027	HANDLE ASSEMBLY		3	3	
3	G	M21 EA5 521	GRILLE		1	1	
4	G	M21 EA1 245	SERVICE PANEL		1	1	Without LABEL
5	G	T92 505 801	COMPRESSOR	MC	1	1	TNB220FMCH
6	G	M21 L2V 505	COMPRESSOR RUBBER SET		3	3	3RUBBERS SET
7	G	M21 L2V 401	EXPANSION VALVE			1	E room
	G	M21 9T4 655	LEV COIL	LEV E		1	E room
8	G	M21 L2V 401	EXPANSION VALVE		1	1	D room
	G	M21 9T4 654	LEV COIL	LEV D	1	1	D room
9	G	M21 L2V 401	EXPANSION VALVE		1	1	C room
	G	M21 9T4 653	LEV COIL	LEV C	1	1	C room
10	G	M21 L2V 401	EXPANSION VALVE		1	1	B room
	G	M21 9T4 652	LEV COIL	LEV B	1	1	B room
11	G	M21 L2V 401	EXPANSION VALVE		1	1	A room
	G	M21 9T4 651	LEV COIL	LEV A	1	1	A room
12	G	M21 EA5 290	BASE ASSEMBLY		1	1	
13	G	M21 0A2 644	UNION		1	1	Ø12.7, Ø9.52, Ø6.35 SET
14	G	M21 4N9 668	STOP VALVE (LIQUID) 3/8		1	1	Ø9.52
15	G	M21 4N0 667	STOP VALVE (GAS) 5/8		1	1	Ø15.88
16	G	M21 EA0 248	REAR PANEL		1	1	
17	G	M21 L2V 646	HIGH PRESSURE SWITCH	HPS	1	1	4.8 MPa (48.9 kg/cm ²)
18	G	M21 L2V 642	4-WAY VALVE		1	1	
19	G	M21 L2V 402	EXPANSION VALVE		1		F
	G	M21 0A2 402	EXPANSION VALVE			1	F
20	G	M21 9T6 651	LEV COIL	LEV F	1	1	
21	G	M21 EA1 297	TOP PANEL		1	1	Without LABEL
22	G	M21 EA1 523	REAR GUARD		1	1	
23	G	M21 6K8 515	MOTOR SUPPORT		1	1	
24	G	T2W 0A2 630	OUTDOOR HEAT EXCHANGER		1	1	
25	G	M21 0A0 293	SEPARATOR		1	1	
26	G	M21 EA0 249	SIDE PANEL		1	1	Including handle
27	G	M21 EAA 959	POWER RECEIVER		1	1	
28	G	M21 0A2 937	CAPILLARY TUBE		2	2	Ø3.0 × Ø2.0 × 300
29	G	M21 0A2 936	CAPILLARY TUBE		4	5	Ø4.0 × Ø2.8 × 100
30	G	M21 L2V 938	CAPILLARY TUBE		1	1	Ø2.5 × Ø0.6 × 1000
31	G	M21 L2V 656	OIL SEPARATOR		1	1	

RoHS PARTS LIST (RoHS compliant)

MXZ-4C80VA2 MXZ-5C100VA2

1-11. OUTDOOR UNIT FUNCTIONAL PARTS AND ELECTRICAL PARTS

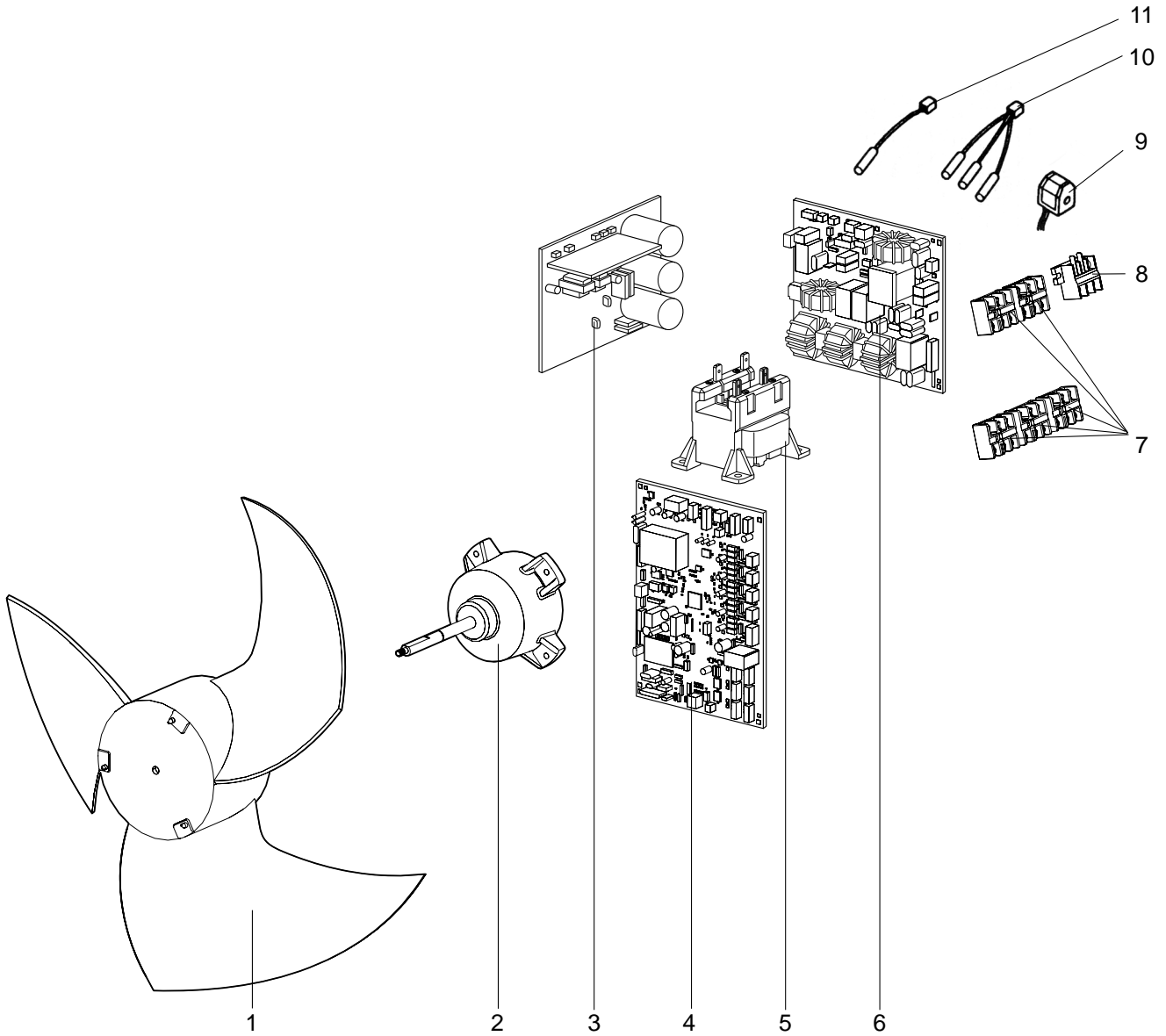

1-12. ACCESSORY

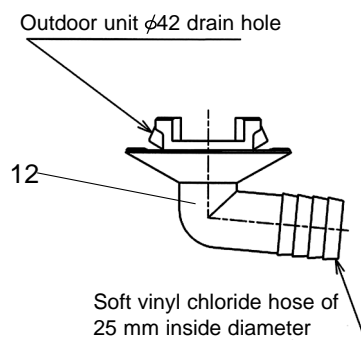

RoHS PARTS LIST (RoHS compliant)

MXZ-4C80VA2 MXZ-5C100VA2

1-11. OUTDOOR UNIT FUNCTIONAL PARTS AND ELECTRICAL PARTS

No.	RoHS	Parts No.	Parts Name	Symbol In Wiring Diagram	Q'ty/unit		Remarks
					MXZ-		
					4C80VA2- [E1]	5C100VA2- [E1]	
1	G	M21 L2V 501	PROPELLER		1	1	
2	G	T2W 3K5 301	OUTDOOR FAN MOTOR	MF	1	1	RC0J60- □□
3	G	M21 9T4 440	POWER BOARD		1	1	Including heat sink and RT64
4	G	T2W 3K8 451	ELECTRONIC CONTROL P.C. BOARD		1		
	G	T2W 3K7 451	ELECTRONIC CONTROL P.C. BOARD			1	
5	G	M21 9T7 337	REACTOR	L	1	1	20A 600μH
6	G	M21 9T5 424	NOISE FILTER P.C. BOARD		1	1	
7	G	T2W 0A2 376	TERMINAL BLOCK	TB2~6	4	5	Indoor unit connecting
8	G	T2W 9T4 377	TERMINAL BLOCK	TB1	1	1	Power supply
9	G	T2W L2V 398	R.V. COIL	21S4	1	1	
10	G	M21 L2V 308	THERMISTOR SET	RT61,62,68	1	1	DEFROST, DISCHARGE, OUTDOOR HEAT EXCHANGER
11	G	M21 0A2 309	AMBIENT TEMPERATURE THERMISTOR	RT65	1	1	

1-12. ACCESSORY

No.	RoHS	Parts No.	Parts Name	Symbol In Wiring Diagram	Q'ty/unit		Remarks
					MXZ-		
					4C80VA2- [E1]	5C100VA2- [E1]	
12	G	M21 8K9 709	DRAIN SOCKET		1	1	

RoHS PARTS LIST (RoHS compliant)

MXZ-6C120VA MXZ-6C122VA

1-13. OUTDOOR UNIT FUNCTIONAL PARTS AND ELECTRICAL PARTS

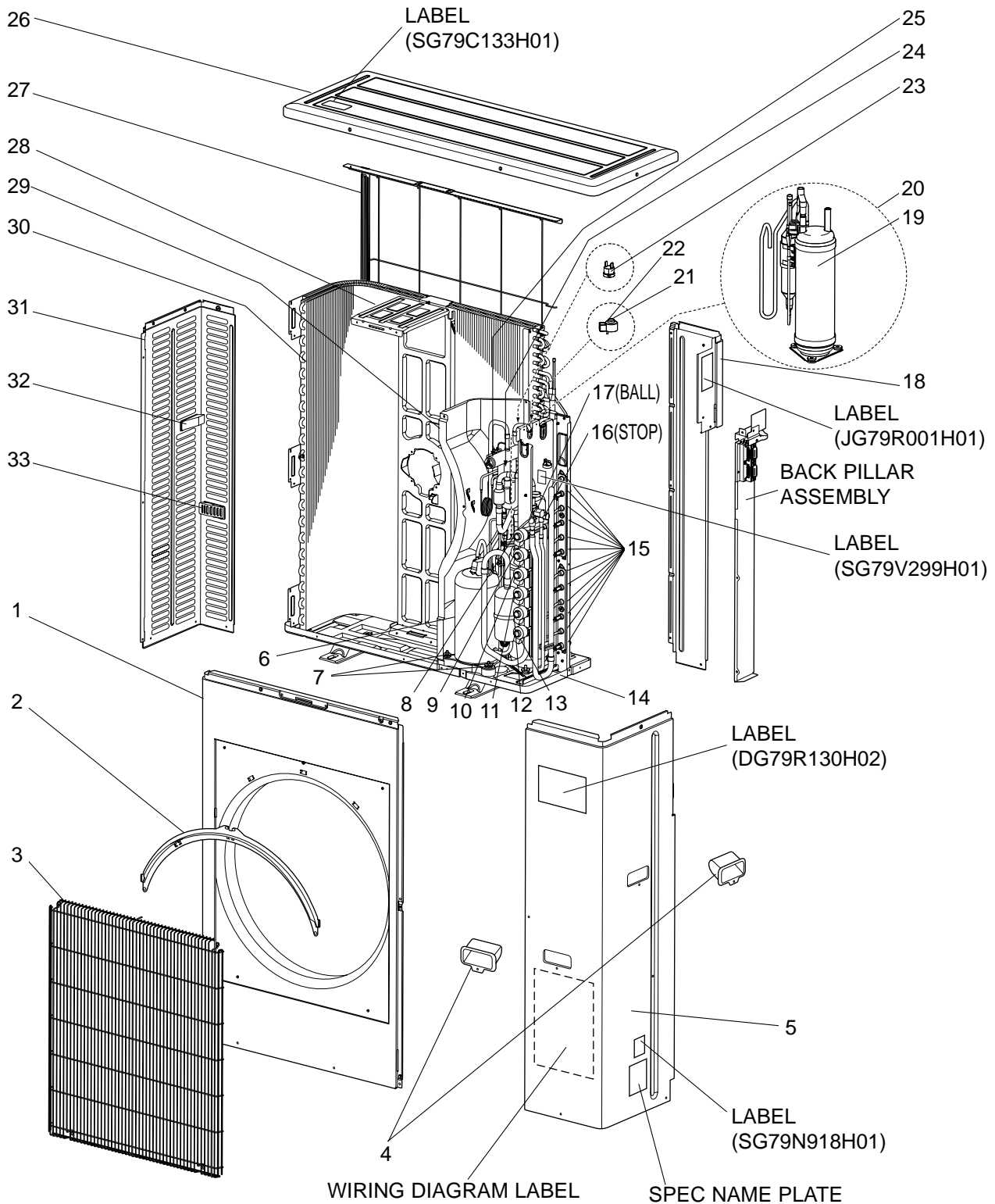

RoHS PARTS LIST (RoHS compliant)

MXZ-6C120VA MXZ-6C122VA

1-13. OUTDOOR UNIT FUNCTIONAL PARTS AND ELECTRICAL PARTS

Part numbers that are circled are not shown in the illustration.

No.	ROHS	Parts No.	Parts Name	Symbol In Wiring Diagram	Q'ty/unit			Remarks
					MXZ-			
					6C120VA - [E1]	6C120VA - [E2]	6C122VA - [E1]	
1	G	T2W 2Y7 232	FRONT PANEL		1	1	1	
2	G	M21 2Y7 750	GRILLE ROOF		1	1	1	
3	G	T2W 2Y7 010	GRILLE		1	1	1	
4	G	M21 1Y7 027	HANDLE ASSEMBLY		2	2	2	
5	G	T2W 2Y7 245	SERVICE PANEL		1			Without LABEL
	G	M21 EA4 245	SERVICE PANEL			1	1	Without LABEL
6	G	T92 509 802	COMPRESSOR	MC	1			TNB306FPGM3
	G	T92 EA0 617	COMPRESSOR	MC		1	1	TNB306FPGM2
7	G	M21 L2V 505	COMPRESSOR RUBBER SET		3	3	3	3RUBBERS SET
8	G	M21 L2V 401	EXPANSION VALVE		1	1	1	F room
	G	M21 1W6 651	LEV COIL	LEV F	1	1	1	F room
9	G	M21 L2V 401	EXPANSION VALVE		1	1	1	E room
	G	M21 1W5 651	LEV COIL	LEV E	1	1	1	E room
10	G	M21 L2V 401	EXPANSION VALVE		1	1	1	D room
	G	M21 1W4 651	LEV COIL	LEV D	1	1	1	D room
11	G	M21 L2V 401	EXPANSION VALVE		1	1	1	C room
	G	M21 1W3 651	LEV COIL	LEV C	1	1	1	C room
12	G	M21 L2V 401	EXPANSION VALVE		1	1	1	B room
	G	M21 1W2 651	LEV COIL	LEV B	1	1	1	B room
13	G	M21 L2V 401	EXPANSION VALVE		1	1	1	A room
	G	M21 1W1 651	LEV COIL	LEV A	1	1	1	A room
14	G	T2W 2Y7 290	BASE ASSEMBLY		1	1	1	
15	G	M21 2Y7 644	UNION		1	1	1	Ø12.7,Ø9.52,Ø6.35 SET
16	G	M21 2Y7 667	STOP VALVE (LIQUID) 3/8		1	1	1	Ø9.52
17	G	M21 9E4 668	BALL VALVE (GAS) 5/8		1	1	1	Ø15.88
18	G	T2W 2Y7 531	BACK PANEL		1			Without LABEL
	G	M21 EA9 531	BACK PANEL			1	1	Without LABEL
19	G	M21 EA0 934	ACCUMULATOR ASSEMBLY			1	1	
20	G	M21 EA0 933	ACCUMULATOR AND PIPE ASSEMBLY			1	1	
21	G	M21 2Y7 402	EXPANSION VALVE		1	1	1	M
22	G	M21 1W7 651	LEV COIL	LEV M	1	1	1	
23	G	M21 L2V 646	HIGH PRESSURE SWITCH	HPS	1	1	1	4.8 MPa (48.9 kg/cm ²)
24	G	T2W 2Y7 645	4-WAY VALVE ASSEMBLY		1	1	1	
25	G	M21 2Y7 642	4-WAY VALVE		1	1	1	
26	G	T2W 2Y7 297	TOP PANEL		1	1	1	Without LABEL
27	G	T2W 2Y7 523	REAR GUARD		1	1	1	
28	G	M21 EA2 515	MOTOR SUPPORT		1	1	1	
29	G	M21 EA3 293	SEPARATOR		1	1	1	
30	G	T2W 2Y7 630	OUTDOOR HEAT EXCHANGER		1			
	G	M21 EAT 630	OUTDOOR HEAT EXCHANGER			1	1	
31	G	T2W 2Y7 249	SIDE PANEL		1	1	1	
32	G	M21 2Y5 027	HANDLE		1	1	1	
33	G	M21 2Y7 027	HANDLE		1	1	1	
(34)	G	M21 T0A 641	2-WAY SOLENOID VALVE		1	1	1	
(35)	G	T2W 2Y7 959	POWER RECEIVER		1			
(36)	G	M21 0A2 936	CAPILLARY TUBE		6	6	6	Ø4.0 × Ø2.8 × 100
(37)	G	M21 L2V 938	CAPILLARY TUBE		1	1	1	Ø2.5 × Ø0.6 × 1000
(38)	G	T2W 2Y7 633	OUT PIPE ASSEMBLY		1			Ø3.6 × Ø2.4 × 600 (×1) Ø3.6 × Ø2.4 × 500 (×5)
	G	M21 EA2 633	OUT PIPE ASSEMBLY			1	1	Ø3.6 × Ø2.4 × 600 (×1) Ø3.6 × Ø2.4 × 500 (×3) Ø3.6 × Ø2.4 × 300 (×2)
(39)	G	M21 EA8 800	TOP FELT		1	1	1	
(40)	G	M21 EA8 801	COMPRESSOR FELT		1	1	1	

RoHS PARTS LIST (RoHS compliant)

MXZ-6C120VA MXZ-6C122VA

1-14. OUTDOOR UNIT FUNCTIONAL PARTS AND ELECTRICAL PARTS

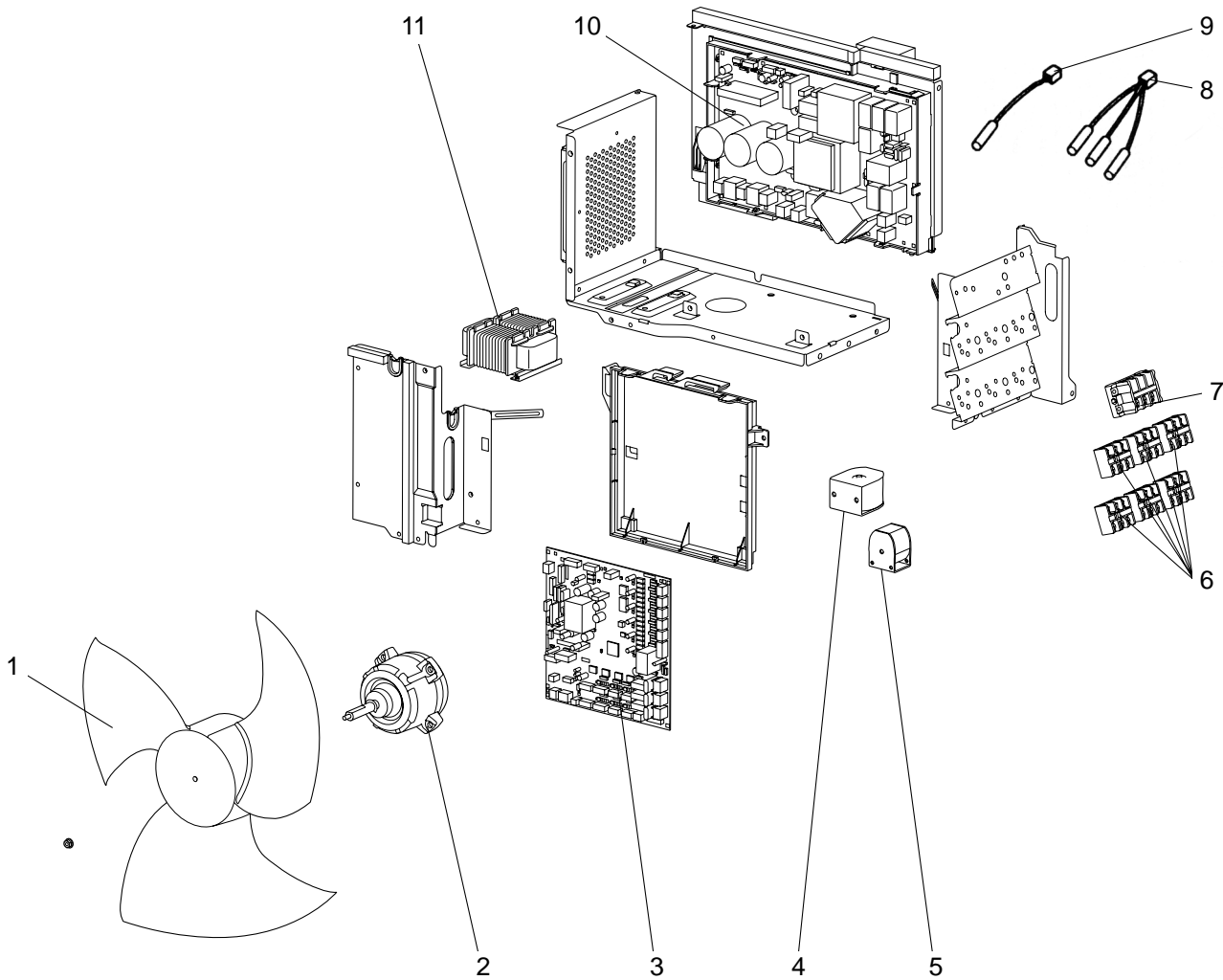

1-15. ACCESSORY

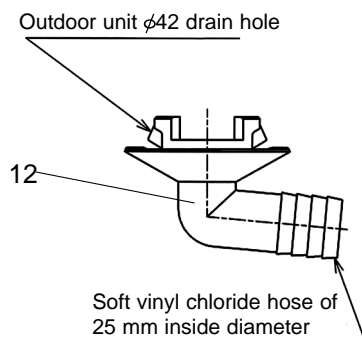

RoHS PARTS LIST (RoHS compliant)

MXZ-6C120VA MXZ-6C122VA

1-14. OUTDOOR UNIT FUNCTIONAL PARTS AND ELECTRICAL PARTS

No.	RoHS	Parts No.	Parts Name	Symbol In Wiring Diagram	Q'ty/unit			Remarks
					MXZ-			
					6C120VA - [E1]	6C120VA - [E2]	6C122VA - [E1]	
1	G	T2W 2Y7 501	PROPELLER		1	1	1	
2	G	T2W 2Y7 301	OUTDOOR FAN MOTOR	MF	1	1	1	SIC-81FW-D888-□
3	G	T2W EG3 451	CONTROL P.C. BOARD		1			
	G	T2W EH3 451	CONTROL P.C. BOARD			1		
	G	T2W EK5 451	OUTDOOR CONTROL P.C. BOARD				1	
4	G	T2W 2Y7 399	2-WAY VALVE SORENOIDE COIL	21S2	1	1	1	
5	G	T2W 2Y7 398	R.V. COIL	21S4	1	1	1	
6	G	T2W 0A2 376	TERMINAL BLOCK	TB2~7	6	6	6	Indoor unit connecting
7	G	T2W E65 375	TERMINAL BLOCK	TB1	1	1	1	Power supply
8	G	M21 2Y7 308	THERMISTOR SET	RT61,62,68	1	1	1	DEFROST, DISCHARGE, OUTDOOR HEAT EXCHANGER
9	G	M21 2Y7 309	AMBIENT TEMPERATURE THERMISTOR	RT65	1	1	1	
10	G	T2W 2Y7 440	POWER BOARD		1	1		
	G	T2W 2Y7 440	OUTDOOR POWER P.C. BOARD				1	
11	G	T2W 2Y7 337	REACTOR	L	1	1	1	20A 600μH

1-15. ACCESSORY

No.	RoHS	Parts No.	Parts Name	Symbol In Wiring Diagram	Q'ty/unit			Remarks
					MXZ-			
					6C120VA - [E1]	6C120VA - [E2]	6C122VA - [E1]	
12	G	M21 8K9 709	DRAIN SOCKET		1	1	1	

2-1. DIFFERENT-DIAMETER PIPE

Model name	Connected pipes diameter	Diameter A	Diameter B	Length C	
MXZ-2C52VA MXZ-3C54VA MXZ-3C68VA MXZ-4C71VA MXZ-4C80VA MXZ-4C80VA2 MXZ-5C100VA MXZ-5C100VA2 MXZ-6C120VA MXZ-6C122VA					
For different-diameter pipes	MAC-A454JP	$\phi 9.52 - \phi 12.7$ (3/8) (1/2)	$\phi 9.52$ (3/8)	$\phi 12.7$ (1/2)	69
	MAC-A455JP	$\phi 12.7 - \phi 9.52$ (1/2) (3/8)	$\phi 12.7$ (1/2)	$\phi 9.52$ (3/8)	65
	MAC-A456JP	$\phi 12.7 - \phi 15.88$ (1/2) (5/8)	$\phi 12.7$ (1/2)	$\phi 15.88$ (5/8)	66.5
	PAC-493PI	$\phi 6.35 - \phi 9.52$ (1/4) (3/8)	$\phi 6.35$ (1/4)	$\phi 9.52$ (3/8)	60.5
	PAC-SG76RJ-E	$\phi 9.52 - \phi 15.88$ (3/8) (5/8)	$\phi 9.52$ (3/8)	$\phi 15.88$ (5/8)	101.5

Unit: mm (inch)

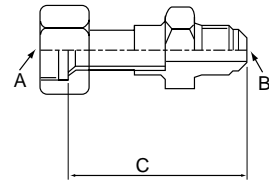

2-2. OUTLET GUIDE

Changes air discharge direction.

Applied unit	Model name	Model code
MXZ-2C30VA MXZ-2C40VA MXZ-2C52VA	MAC-889SG	506-889
MXZ-3C54VA MXZ-3C68VA MXZ-4C71VA MXZ-4C80VA MXZ-4C80VA2 MXZ-5C100VA MXZ-5C100VA2	MAC-856SG	51H-856
MXZ-6C120VA MXZ-6C122VA	MAC-857SG	551H-857

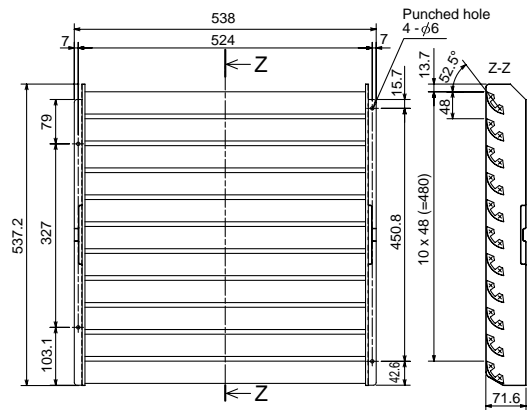

MAC-889SG

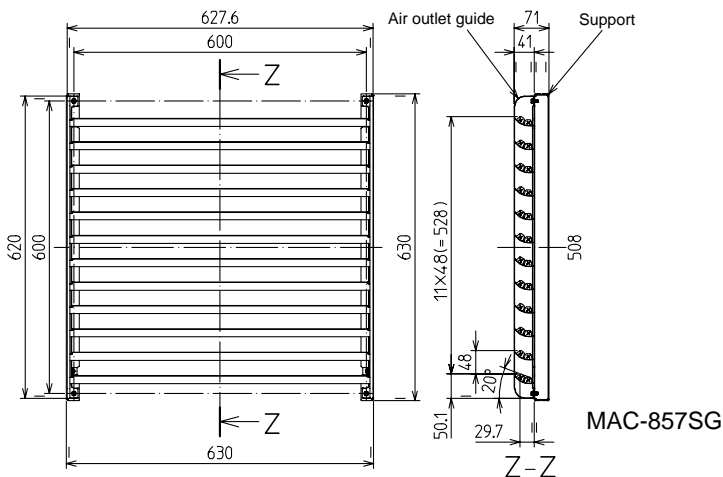

MAC-857SG

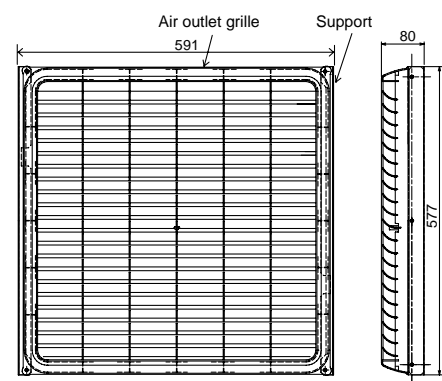

MAC-856SG

MITSUBISHI ELECTRIC CORPORATION

HEAD OFFICE: TOKYO BLDG., 2-7-3, MARUNOUCHI, CHIYODA-KU, TOKYO 100-8310, JAPAN

© Copyright 2010 MITSUBISHI ELECTRIC CORPORATION
 Distributed in Dec. 2012. No.OBB584 REVISED EDITION-D
 Distributed in Jul. 2012. No.OBB584 REVISED EDITION-C
 Distributed in Jun. 2012. No.OBB584 REVISED EDITION-B
 Distributed in Apr. 2011. No.OBB584 REVISED EDITION-A
 Distributed in Oct. 2010. No.OBB584
 Made in Japan

New publication, effective Dec. 2012
 Specifications are subject to change without notice.