

**MITSUBISHI ELECTRIC**

**CITY MULTI**

**Air-Conditioners  
OUTDOOR UNIT**

**PUHY-YSMF-B**

**FOR INSTALLER  
FÜR INSTALLATEUR  
POUR L'INSTALLATEUR  
VOOR DE INSTALLATEUR  
PER L'INSTALLATORE**

ENGLISH

DEUTSCH

FRANÇAIS

## **INSTALLATION MANUAL**

For safe and correct use, please read this installation manual thoroughly before installing the air-conditioner unit.

\* Remote controller (PAR-F25MA) is available as an optional remote controller.

## **INSTALLATIONSHANDBUCH**

Zum sicheren und ordnungsgemäßen Gebrauch der Klimageräte das Installationshandbuch gründlich durchlesen.

\* Fernbedienung (PAR-F25MA) ist als Zubehör wahlweise erhältlich.

## **MANUEL D'INSTALLATION**

Veillez lire le manuel d'installation en entier avant d'installer ce climatiseur pour éviter tout accident et vous assurer d'une utilisation correcte.

\* La télécommande (PAR-F25MA) est disponible en option.

## **INSTALLATIEHANDLEIDING**

Voor een veilig en juist gebruik moet u deze installatiehandleiding grondig doorlezen voordat u de airconditioner installeert.

\* De afstandsbedieningseenheid (PAR-F25MA) is verkrijgbaar als een optioneel toe te voegen afstandsbediening.

## **MANUALE DI INSTALLAZIONE**

Per un uso sicuro e corretto, leggere attentamente questo manuale di installazione prima di installare il condizionatore d'aria.

\* Il comando a distanza (modello PAR-F25MA) disponibile in opzione.

NEDERLANDS

ITALIANO

# Contents

---

1. Safety precautions .....	3
1.1. Before installation and electric work .....	3
1.2. Before getting installed .....	3
1.3. Before getting installed (moved) - electrical work .....	4
1.4. Before starting the test run .....	4
2. Combination with indoor units .....	5
3. Confirmation of parts attached .....	5
4. Outdoor unit configuration .....	6
5. Selection of installation site .....	6
6. Space required around unit .....	7
6.1. Individual installation .....	7
6.2. Collective installation and continuous installation .....	8
7. Lifting method and weight of product .....	8
8. Installation of unit .....	9
8.1. Location of anchor bolt .....	9
8.2. Installation .....	9
8.3. Connecting direction for refrigerant piping .....	10
8.4. Noise level .....	10
9. Caution for snow and seasonal wind .....	11
9.1. Snow and seasonal wind .....	11
9.2. Countermeasure to seasonal wind .....	11
10. Refrigerant piping installation .....	12
10.1. Areas of caution .....	12
10.2. Refrigerant piping system .....	13
10.3. Precautions concerning piping connection and valve operation .....	15
10.4. Oil balance pipe connection method .....	18
10.5. Distributor (gas) connection method .....	19
10.6. How to install branch pipe .....	20
10.7. Airtight test and evacuation .....	21
10.8. Thermal insulation of refrigerant piping .....	22
11. Electrical work .....	24
11.1. Caution .....	24
11.2. Control box and connecting position of wiring .....	25
11.3. Wiring transmission cables .....	27
11.4. Wiring of main power supply and equipment capacity .....	33
12. Test run .....	34
12.1. Checking before getting test run .....	34
12.2. Test run method .....	34
12.3. How to cope with test run abnormality .....	35
12.4. Coping with remote controller abnormality .....	37
12.5. The following phenomena do not represent abnormality (emergency) .....	38

# 1. Safety precautions

## 1.1. Before installation and electric work

- ▶ **Before installing the unit, make sure you read all the “Safety precautions”.**
- ▶ **The “Safety precautions” provide very important points regarding safety. Make sure you follow them.**

### Symbols used in the text









#### **Warning:**

Describes precautions that should be observed to prevent danger of injury or death to the user.

#### **Caution:**

Describes precautions that should be observed to prevent damage to the unit.

### Symbols used in the illustrations

-  : Indicates an action that must be avoided.
-  : Indicates that important instructions must be followed.
-  : Indicates a part which must be grounded.
-  : Indicates that caution should be taken with rotating parts. (This symbol is displayed on the main unit label.) <Color: Yellow>
-  : Indicates that the main switch must be turned off before servicing. (This symbol is displayed on the main unit label.) <Color: Blue>
-  : Beware of electric shock (This symbol is displayed on the main unit label.) <Color: Yellow>
-  : Beware of hot surface (This symbol is displayed on the main unit label.) <Color: Yellow>
-  **ELV** : Please pay attention to electric shock fully because this is not Safety Extra Low-Voltage (SELV) circuit. And at servicing, please shut down the power supply for both of Indoor Unit and Outdoor Unit.

#### **Warning:**

**Carefully read the labels affixed to the main unit.**

#### **Warning:**

- **Ask the dealer or an authorized technician to install the air conditioner.**
  - Improper installation by the user may result in water leakage, electric shock, or fire.
- **Install the air unit at a place that can withstand its weight.**
  - Inadequate strength may cause the unit to fall down, resulting in injuries.
- **Use the specified cables for wiring. Make the connections securely so that the outside force of the cable is not applied to the terminals.**
  - Inadequate connection and fastening may generate heat and cause a fire.
- **Prepare for typhoons and other strong winds and earthquakes and install the unit at the specified place.**
  - Improper installation may cause the unit to topple and result in injury.
- **Always use an air cleaner, humidifier, electric heater, and other accessories specified by Mitsubishi Electric.**
  - Ask an authorized technician to install the accessories. Improper installation by the user may result in water leakage, electric shock, or fire.
- **Never repair the unit. If the air conditioner must be repaired, consult the dealer.**
  - If the unit is repaired improperly, water leakage, electric shock, or fire may result.
- **Do not touch the heat exchanger fins.**
  - Improper handling may result in injury.
- **If refrigerant gas leaks during installation work, ventilate the room.**

- If the refrigerant gas comes into contact with a flame, poisonous gases will be released.
- **Install the air conditioner according to this Installation Manual.**
  - If the unit is installed improperly, water leakage, electric shock, or fire may result.
- **Have all electric work done by a licensed electrician according to “Electric Facility Engineering Standard” and “Interior Wire Regulations” and the instructions given in this manual and always use a special circuit.**
  - If the power source capacity is inadequate or electric work is performed improperly, electric shock and fire may result.
- **Securely install the cover of control box and the panel.**
  - If the cover and panel are not installed properly, dust or water may enter the outdoor unit and fire or electric shock may result.
- **When installing and moving the air conditioner to another site, do not charge the it with a refrigerant different from the refrigerant (R22) specified on the unit.**
  - If a different refrigerant or air is mixed with the original refrigerant, the refrigerant cycle may malfunction and the unit may be damaged.
- **If the air conditioner is installed in a small room, measures must be taken to prevent the refrigerant concentration from exceeding the safety limit even if the refrigerant should leak.**
  - Consult the dealer regarding the appropriate measures to prevent the safety limit from being exceeded. Should the refrigerant leak and cause the safety limit to be exceeded, hazards due to lack of oxygen in the room could result.
- **When moving and reinstalling the air conditioner, consult the dealer or an authorized technician.**
  - If the air conditioner is installed improperly, water leakage, electric shock, or fire may result.
- **After completing installation work, make sure that refrigerant gas is not leaking.**
  - If the refrigerant gas leaks and is exposed to a fan heater, stove, oven, or other heat source, it may generate noxious gases.
- **Do not reconstruct or change the settings of the protection devices.**
  - If the pressure switch, thermal switch, or other protection device is shorted and operated forcibly, or parts other than those specified by Mitsubishi Electric are used, fire or explosion may result.
- **To dispose of this product, consult your dealer.**
- **The installer and system specialist shall secure safety against leakage according to local regulation or standards.**
  - Following standards may be applicable if local regulation are not available.
- **Pay a special attention to the place, such as a basement, etc. where refrigeration gas can stay, since refrigeration is heavier than the air.**

## 1.2. Before getting installed

#### **Caution:**

- **Do not install the unit where combustible gas may leak.**
  - If the gas leaks and accumulates around the unit, an explosion may result.
- **Do not use the air conditioner where food, pets, plants, precision instruments, or artwork are kept.**
  - The quality of the food, etc. may deteriorate.
- **Do not use the air conditioner in special environments.**
  - Oil, steam, sulfuric smoke, etc. can significantly reduce the performance of the air conditioner or damage its parts.
- **When installing the unit in a hospital, communication station, or similar place, provide sufficient protection against noise.**
  - The inverter equipment, private power generator, high-frequency medical equipment, or radio communication equipment may cause the air conditioner to operate erroneously, or fail to operate. On the other hand, the air conditioner may affect such equipment by creating noise that disturbs medical treatment or image broadcasting.
- **Do not install the unit on a structure that may cause leakage.**
  - When the room humidity exceeds 80% or when the drain pipe is clogged, condensation may drip from the indoor unit. Perform collective drainage work together with the outdoor unit, as required.

### 1.3. Before getting installed (moved) - electrical work

#### ⚠ Caution:

- **Ground the unit.**
  - Do not connect the ground wire to gas or water pipes, lightning rods, or telephone ground lines. Improper grounding may result in electric shock.
- **The reverse phase of L lines (L1, L2, L3) can be detected (Error cord: 4103), but the reverse phase of L lines and N line can be not be detected.**
  - The some electric parts should be damaged when power is supplied under the miss wiring.
- **Install the power cable so that tension is not applied to the cable.**
  - Tension may cause the cable to break and generate heat and cause a fire.
- **Install an leak circuit breaker, as required.**
  - If an leak circuit breaker is not installed, electric shock may result.
- **Use power line cables of sufficient current carrying capacity and rating.**
  - Cables that are too small may leak, generate heat, and cause a fire.
- **Use only a circuit breaker and fuse of the specified capacity.**
  - A fuse or circuit breaker of a larger capacity or a steel or copper wire may result in a general unit failure or fire.
- **Do not wash the air conditioner units.**
  - Washing them may cause an electric shock.
- **Be careful that the installation base is not damaged by long use.**
  - If the damage is left uncorrected, the unit may fall and cause personal injury or property damage.
- **Install the drain piping according to this Installation Manual to ensure proper drainage. Wrap thermal insulation around the pipes to prevent condensation.**
  - Improper drain piping may cause water leakage and damage to furniture and other possessions.
- **Be very careful about product transportation.**
  - Only one person should not carry the product if it weighs more than 20 kg.
  - Some products use PP bands for packaging. Do not use any PP bands for a means of transportation. It is dangerous.
  - Do not touch the heat exchanger fins. Doing so may cut your fingers.
  - When transporting the outdoor unit, suspend it at the specified positions on the unit base. Also support the outdoor unit at four points so that it cannot slip sideways.
- **Safely dispose of the packing materials.**
  - Packing materials, such as nails and other metal or wooden parts, may cause stabs or other injuries.
  - Tear apart and throw away plastic packaging bags so that children will not play with them. If children play with a plastic bag which was not torn apart, they face the risk of suffocation.

### 1.4. Before starting the test run

#### ⚠ Caution:

- **Turn on the power at least 12 hours before starting operation.**
  - Starting operation immediately after turning on the main power switch can result in severe damage to internal parts. Keep the power switch turned on during the operational season.
- **Do not touch the switches with wet fingers.**
  - Touching a switch with wet fingers can cause electric shock.
- **Do not touch the refrigerant pipes during and immediately after operation.**
  - During and immediately after operation, the refrigerant pipes are may be hot and may be cold, depending on the condition of the refrigerant flowing through the refrigerant piping, compressor, and other refrigerant cycle parts. Your hands may suffer burns or frost-bite if you touch the refrigerant pipes.
- **Do not operate the air conditioner with the panels and guards removed.**
  - Rotating, hot, or high-voltage parts can cause injuries.
- **Do not turn off the power immediately after stopping operation.**
  - Always wait at least five minutes before turning off the power. Otherwise, water leakage and trouble may occur.

## 2. Combination with indoor units

The indoor units connectable to this unit are shown below.

Outdoor unit model name	Total capacity of connected indoor unit models	Quantity of connectable indoor unit	Model name of connectable indoor unit
PUHY-600	300 to 780	3 to 32	PMFY-P25 · 32 · 40 · 63 PLFY- P32 · 40 · 50 · 63 · 80 · 100 · 125 PLFY- P20 · 25 · 32 · 40 · 50 · 63 · 80 · 100 · 125 PEFY- P20 · 25 · 32 PEFY- P40 · 50 · 63 · 71 · 80 · 100 · 125 · 140 · 200 · 250 PCFY- P40 · 63 · 100 · 125 PKFY- P20 · 25 PKFY- P32 · 40 · 50 PPFY- P20 · 25 · 32 · 40 · 50 · 63 PPFY- P20 · 25 · 32 · 40 · 50 · 63 PDFY- P20 · 25 · 32 · 40 · 50 · 63 · 71 · 80 · 100 · 125
PUHY-650	325 to 845		VBM VKM VLMD VML VMH VGM VAM VGM VLEM VLRM VM
PUHY-700	350 to 910		
PUHY-750	375 to 975		

### Note:

- The total capacity of connected indoor unit models represents the total sum of the figures expressed in the indoor model name.
- Combinations in which the total capacity of the connected indoor units exceeds the capacity of the outdoor unit will reduce the capacity of each indoor unit below the rated capacity during simultaneous operation. Therefore, if circumstances allows, combine indoor units within the capacity of the outdoor unit.
- A transmission booster (RP) is required when the number of connected indoor unit models in a cooling system exceeds the number of models specified in the chart below.

\* The maximum number of units that can be controlled is determined by the indoor unit model, the type of remote controller and their capabilities.



(*1) Capability of the connected indoor units	Remote controller type Number of connected indoor units that can be connected without a RP	Remote controller PAR-F 25MA	
		Prior to Ver. E	After Ver. F
200 or lower		16 (32)	20 (40)
200 or higher		16 (32)	16 (32)

The number of indoor units and the total number of remote controllers is displayed within the parenthesis ( ).

\*1 If even one unit that is higher than 200 exists in the cooling system, the maximum capacity will be "200 or higher".

## 3. Confirmation of parts attached

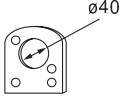
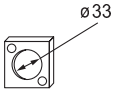
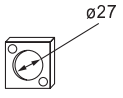
This outdoor unit is attached with the parts below. Please check the quantity for each item.

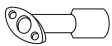
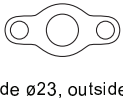
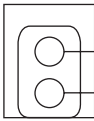
Name	① Conduit mounting plate	② Conduit mounting plate	③ Conduit mounting plate	④ Tapping screw M4 × 12
Shape				
Model name PUHN-200YMF-B PUHN-250YMF-B	1	1	1	4
Name	⑤ Oil balance pipe	⑥ Connecting pipe	⑦ Packing	⑧ Seal
Shape				
Model name PUHN-200YMF-B PUHN-250YMF-B	1	1	1	2







\*⑥ Connecting pipe is fixed with the unit.

## 4. Outdoor unit configuration

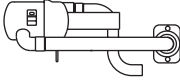
The unit (PUHY-600/650/700/750YSMF-B) consists of a combination of variable capacity units (PUHY-400/500YMF-B) and constant capacity units (PUHN-200/250YMF-B). **A CMC-30A (optional) is required when using a combination of these units.**

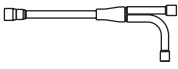
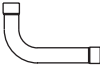
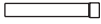
Super Y	Variable capacity unit	Constant capacity unit
PUHY-600YSMF-B	PUHY-400YMF-B	PUHN-200YMF-B
PUHY-650YSMF-B		PUHN-250YMF-B
PUHY-700YSMF-B	PUHY-500YMF-B	PUHN-200YMF-B
PUHY-750YSMF-B		PUHN-250YMF-B

CMC-30A (optional)

		① Distributer (gas)	② Oil balance pipe 2	③ Distributer (liquid)	④ Connecting pipe
Shape					
Model name	CMC-30A	1	1	1	1
	Name	⑤ Connecting pipe	⑥ Connecting pipe	⑦ Connecting pipe	⑧ Elbow
Shape					
Model name	CMC-30A	1	1	1	2

## 5. Selection of installation site

Select space for installing outdoor unit, which will meet the following conditions:

- no direct thermal radiation from other heat sources
  - no possibility of annoying neighbors by noise from unit
  - no exposition to strong wind
  - with strength which bears weight of unit
  - note that drain flows out of unit when heating
  - with space for air passage and service work shown below
- Because of the possibility of fire, do not install unit to the space where generation, inflow, stagnation, and leak of combustible gas is expected.
- Avoid unit installation in a place where acidic solution and spray (sulfur) are often used.
  - When having cooling operation at an outside air temperature of below 10°C, in order to obtain steady operation of unit, select an installation site not exposed directly to rain and snow, or install air outlet and inlet ducts. (Refer to Page 11.) Install the outdoor unit at the same position on the same floor, or above, the indoor unit. (See the figure at the right.)
  - Do not use unit in any special environment where oil, steam and sulfuric gas exist.

Installation restriction on outdoor unit when cooling operation is performed when the outdoor air temperature is 10°C or lower.

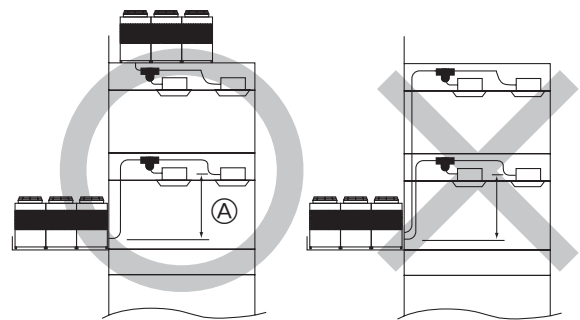

(Same floor as indoor unit, or floor above)

Ⓐ 4 m or less

# 6. Space required around unit

## 6.1. Individual installation

### Basic space required

A space of at least 250 mm is necessary at the back for inlet air. Taking servicing, etc. from the rear into account, a space of about 450 mm should be provided, the same as at the front.

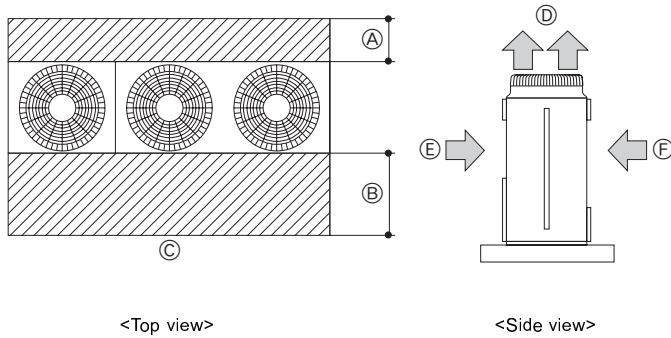

- (A) 250 mm or more
- (B) 450 mm or more
- (C) Front (outside of machine room)
- (D) Top discharge (open in principle)
- (E) Front inlet (open in principle)
- (F) Rear inlet (open in principle)

### When inlet air enters from right and left sides of unit

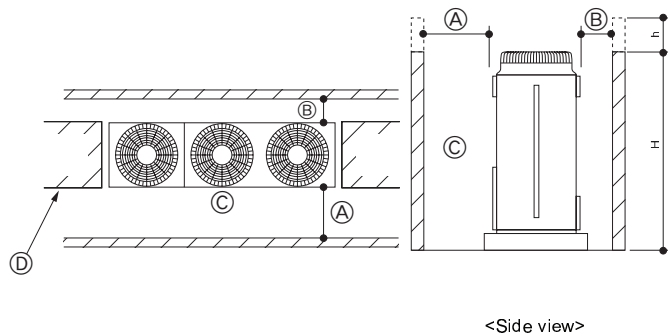

- (A) L1 or more
- (B) L2 or more
- (C) Front
- (D) No restrictions on wall height (left and right)

### Note:

- Wall heights (H) of the front and the back sides shall be within overall height of unit.
- When the total height is exceeded, add the “h” dimension of the figure above to L1 and L2 in the table above.

L1	L2
450	250

### When unit is surrounded by walls

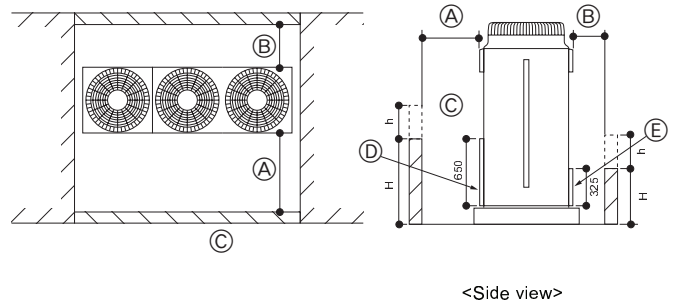

- (A) L1 or more
- (B) L2 or more
- (C) Front
- (D) Front panel
- (E) Rear panel

### Note:

- Wall heights (H) of the front and the back sides shall be within height of front panel and rear panel.
- If the panel height is exceeded, add the “h” dimension of the figure above to L1 and L2 in the table above.

L1	L2
450	250

Example: When h is 100

The L1 dimension becomes 450 + 100 = 550 mm.

### When there is an obstruction above the unit

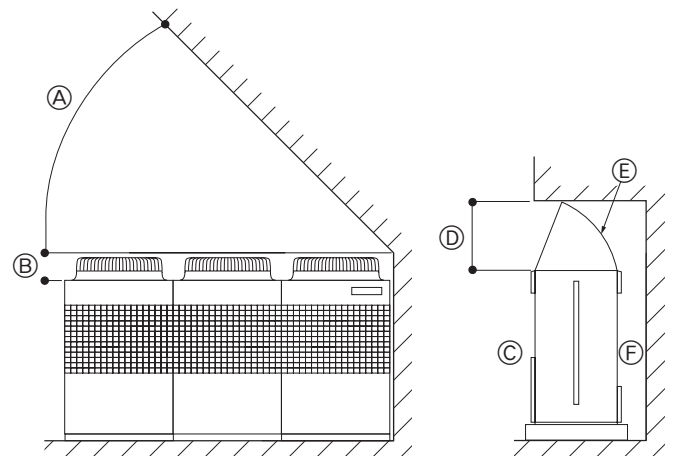

- (A) 45° or more
- (B) 300 mm or more
- (C) Front
- (D) 1000 mm or more
- (E) Air outlet guide (procured at the site)
- (F) Rear

## 6.2. Collective installation and continuous installation

Space required for collective installation and continuous installation:  
When installing several units, leave the space between each block as shown below considering passage for air and people.

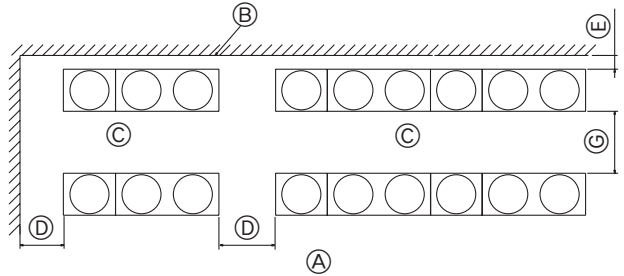
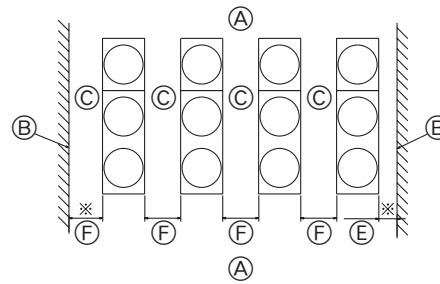
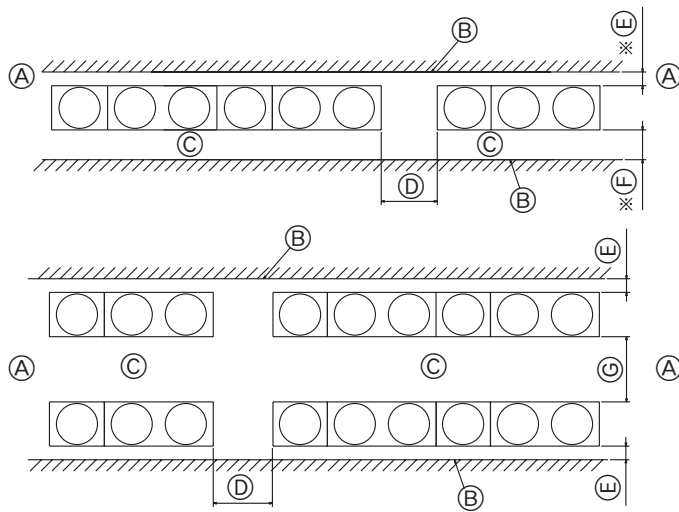

- A (Must be open)
- B Wall height (H)
- C Front
- D 1000 mm or more
- E 250 mm or more
- F 450 mm or more
- G 900 mm or more

### Note:

- Open in the two directions.
- In case wall height (H) exceeds overall height of unit, add "h" dimension (h = wall height <H> - overall height of unit) to \* marked dimension.
- If there is a wall at both the front and the rear of the unit, install up to three units consecutively in the side direction and provide a space of 1000 mm or more as inlet space/passage space for each three units.

## 7. Lifting method and weight of product

- When carrying the unit suspended, pass the ropes under the unit and use the two suspension points each at the front and rear.
- Always lift the unit with ropes attached at four points so that impact is not applied to the unit.
- Attach the ropes to the unit at an angle of 40° or less.
- Use two ropes at least A m long.  $A = \begin{cases} 7 \dots \text{PUHN-200/250YMF-B} \\ 8 \dots \text{PUHY-400/500YMF-B} \end{cases}$

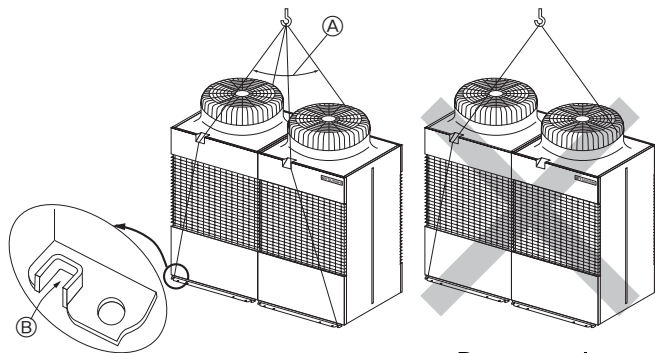

- A 40° or less
- B Rope suspension part

Weight of product:

PUHY-400	PUHY-500	PUHN-200	PUHN-250
432 kg	472 kg	240 kg	255 kg

### ⚠ Caution:

**Be very careful to carry product.**

- Do not have only one person to carry product if it is more than 20 kg.
- PP bands are used to pack some products. Do not use them as a mean for transportation because they are dangerous.
- Do not touch heat exchanger fins with your bare hands. Otherwise you may get a cut in your hands.
- Tear plastic packaging bag and scrap it so that children cannot play with it. Otherwise plastic packaging bag may suffocate children to death.
- When carrying in outdoor unit, be sure to support it at four points. Carrying in and lifting with 3-point support may make outdoor unit unstable, resulting in a fall of it.



## 8. Installation of unit

### 8.1. Location of anchor bolt

Mount the constant capacity unit on the left and variable capacity unit on the right of the same frame (as seen from the front of the unit). Allow 10 mm of clearance between the units.

- Individual installation

(Unit: mm)

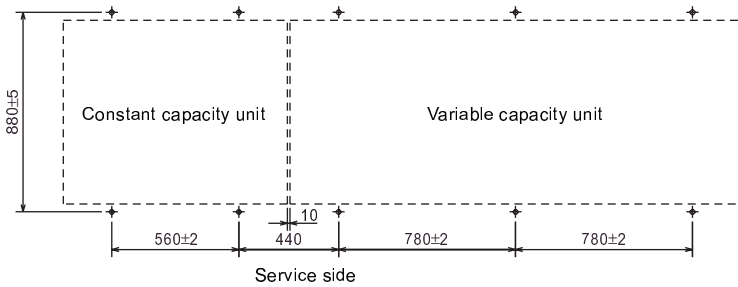

- Example of collective installation

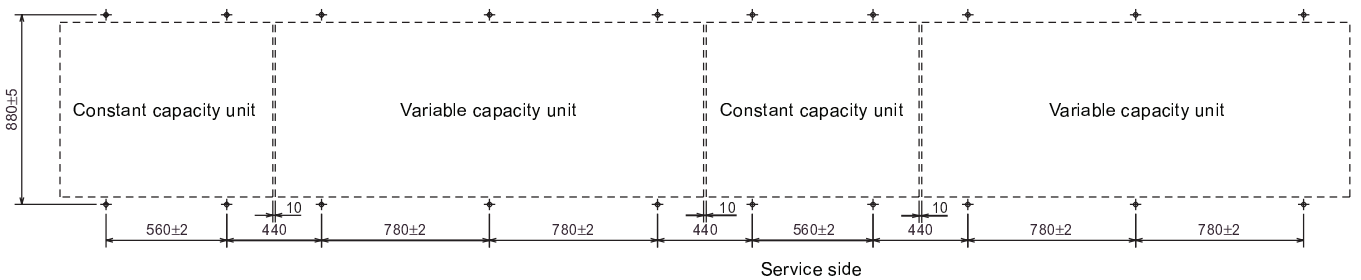

For collective installation, provide a 10 mm gap between units.

### 8.2. Installation

- Fix unit tightly with bolts as shown below so that unit will not fall down due to earthquake or gust.
- Use concrete or angle for foundation of unit.
- Vibration may be transmitted to the installation section and noise and vibration may be generated from the floor and walls, depending on the installation conditions. Therefore, provide ample vibrationproofing (cushion pads, cushion frame, etc.).

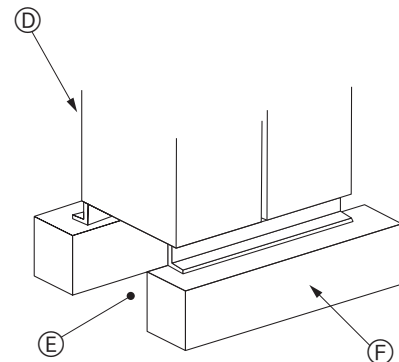
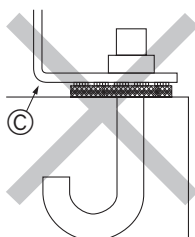
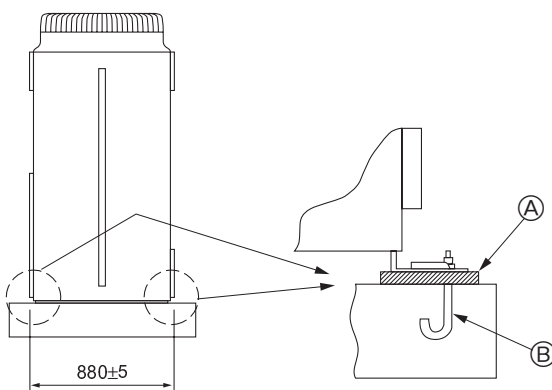

- (A) Be sure that the corners are firmly seated. If the corners are not firmly seated, the installation feet may be bent
- (B) M10 anchor bolt procured at the site
- (C) Corner is not seated.
- (D) Unit  
(Provide ample vibrationproofing between the unit and the foundation by using cushion pads, cushion frame, etc.)
- (E) Piping and wiring space (bottom piping, bottom wiring)
- (F) Concrete foundation

#### ⚠ Warning:

- Be sure to install unit in a place strong enough to withstand its weight.  
Any lack of strength may cause unit to fall down, resulting in a personal injury.
- Have installation work in order to protect against a strong wind and earthquake.  
Any installation deficiency may cause unit to fall down, resulting in a personal injury.

When building the foundation, give full attention to the floor strength, drain water disposal <during operation, drain water flows out of the unit>, and piping and wiring routes.

**Down piping and down wiring precautions**

When down piping and down wiring are performed, be sure that foundation and base work does not block the base through holes. When down piping is performed, make the foundation at least 150 mm high so that the piping can pass under the bottom of the unit.

<PUHN-200/250YMF-B>

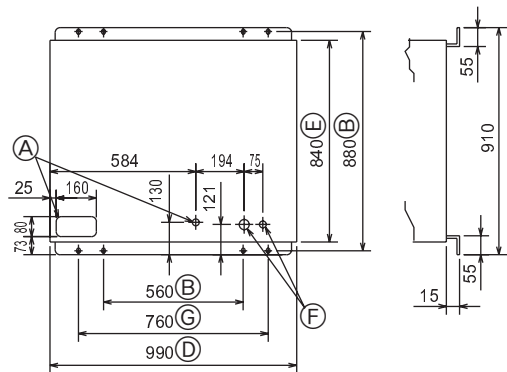

<PUHY-400/500YMF-B>

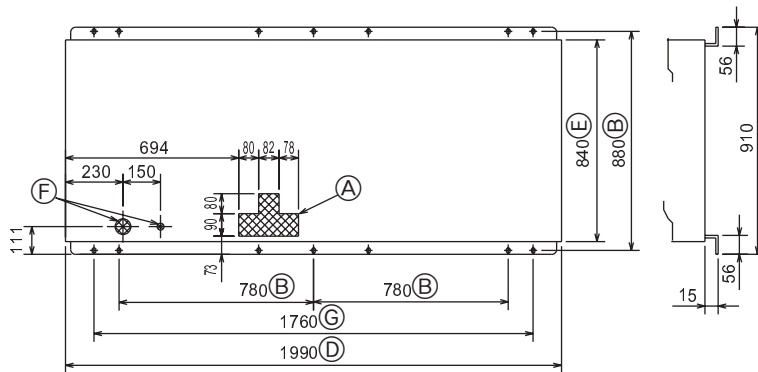

- Ⓐ Bottom piping through hole
- Ⓑ (bolt hole)
- Ⓒ (bolt hole for old models)
- Ⓓ (unit width)
- Ⓔ (unit depth)
- Ⓕ Bottom wiring through hole
- Ⓖ (bolt hole for packing)

**8.3. Connecting direction for refrigerant piping**

Two connecting directions are available for refrigerant piping of the outdoor unit, bottom piping and front piping, as shown below:

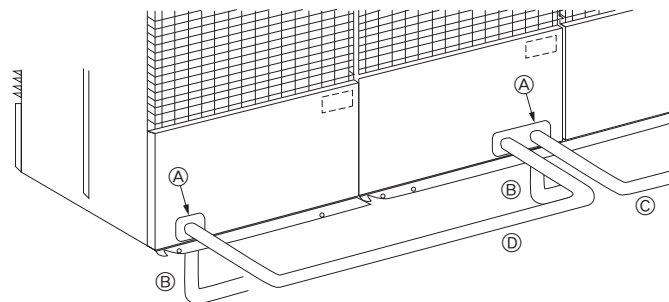

- Ⓐ Knock-out hole
- Ⓑ Bottom piping
- Ⓒ Front piping
- Ⓓ Connect piping (to constant capacity unit)

**Note:**

In the case of bottom piping, build a 100 mm or higher foundation so that piping will go through the bottom of the unit.

**8.4. Noise level**

(50/60Hz)

PUHY-400	PUHY-500	PUHN-200	PUHN-250
60/61 dB (A-weighted)		56 dB (A-weighted)	57 dB (A-weighted)

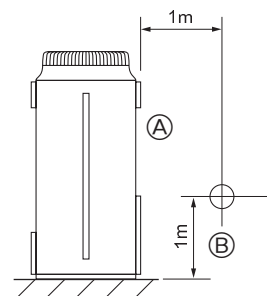

- Ⓐ Front
- Ⓑ Measuring point

Measuring location: a room free from echoes and reverberations

## 9. Caution for snow and seasonal wind

In cold and/or snowy areas, sufficient countermeasures to wind and snow damages should be taken for operating unit in normal and good condition in winter time. Even in the other areas, full consideration is required for installation of unit in order to prevent abnormal operations caused by seasonal wind or snow. **When rain and snow directly fall on unit in the case of air-conditioning operations in 10 or less degrees centigrade outdoor air, mount inlet and outlet ducts on unit for assuring stable operations.**

### 9.1. Snow and seasonal wind

- Prevention of wind and snow damages in cold or snowy areas:  
Refer to the figure of snow hood shown below:
- Snow hood

#### Note:

1. Height of frame base for snow damage prevention (H) shall be twice as high as expected snowfall. Width of frame base shall not exceed that of the unit. The frame base shall be made of angle steel, etc., and designed so that snow and wind slip through the structure. (If frame base is too wide, snow will be accumulated on it.)
2. Install unit so that seasonal wind will not directly lash against openings of inlet and outlet ducts.
3. Build frame base at customer referring to this figure.  
Material : Galvanized steel plate 1.2T  
Painting : Overall painting with polyester powder  
Color : Munsell 5Y8/1 (same as that of unit)
4. When the unit is used in a cold region and the heating operation is continuously performed for a long time when the outside air temperature is below freezing, install a heater to the unit base or take other appropriate measures to prevent water from freezing on the base.

<PUHY-400/500YMF-B>

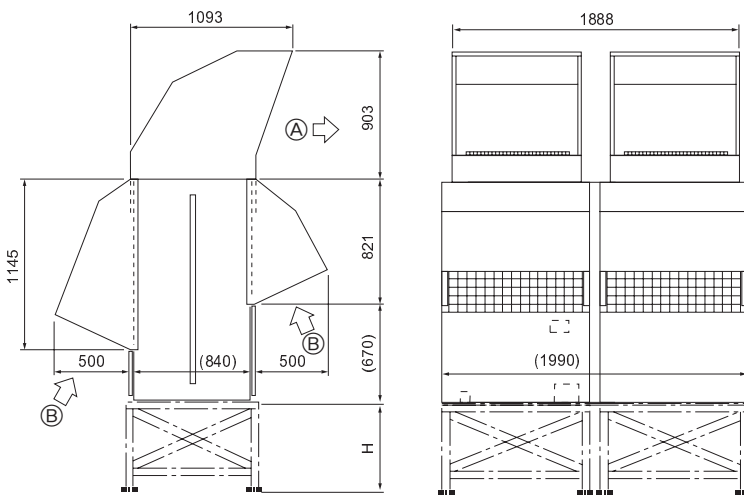

<PUHN-200/250YMF-B>

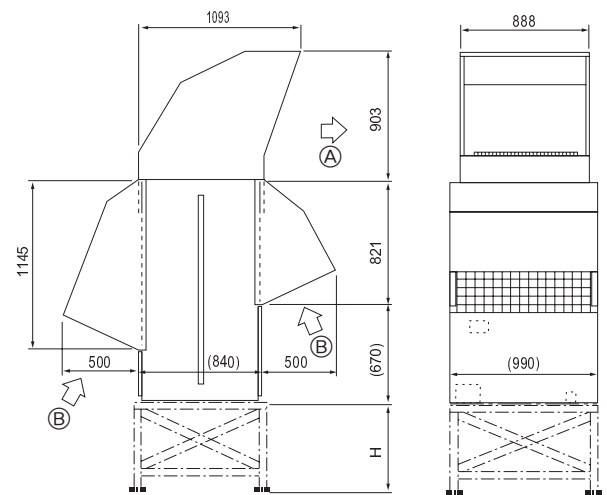

- Ⓐ Outlet
- Ⓑ Inlet

### 9.2. Countermeasure to seasonal wind

Referring to the figure shown below, take appropriate measures which will suit the actual situation of the place for installation.

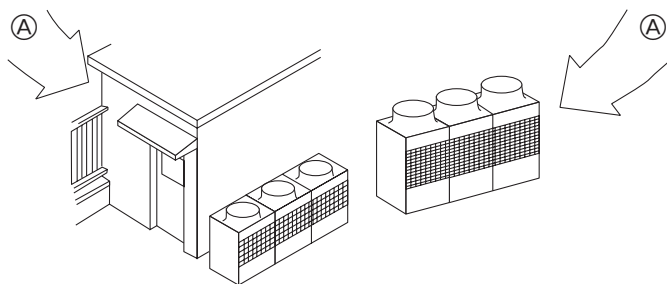

- Ⓐ Seasonal wind

# 10. Refrigerant piping installation

Connecting the piping is a terminal-branch type in which refrigerant piping from the outdoor unit is branched at the terminal and connected to each of the indoor units.

The method of connection consists of flare connections at the indoor units, flange connections for the piping of the outdoor unit and flare connections for the liquid, oil balance piping. Note that the branched sections are brazed.

**⚠ Warning:**

**Always use extreme care to prevent the refrigerant gas (R22) from leaking while using fire or flame. If the refrigerant gas comes in contact with the flame from any source, such as a gas stove, it breaks down and generates a poisonous gas which can cause gas poisoning. Never weld in an unventilated room. Always conduct an inspection for gas leakage after installation of the refrigerant piping has been completed.**

## 10.1. Areas of caution

- ① Use the following materials for refrigeration piping.
  - Material: Seamless phosphorous deoxidized copper pipe, C1220T-OL or C1220T-O (Note: C1220T-OL is preferred.)
  - Size: Refer to pages 13 to 14.
- ② Commercially available piping often contains dust and other materials. Always blow it clean with a dry inert gas.
- ③ Use care to prevent dust, water or other contaminants from entering the piping during installation.
- ④ Reduce the number of bending portions as much as possible, and make bending radius as big as possible.
- ⑤ Always use the branch piping set shown below, which are sold separately. **This unit requires a CMC-30A (optional).**

Branch pipe set name						
Line branching				Header branching		
Total of units downstream less than 160	Total of units downstream 161 to 330	Total of units downstream 331 to 630	Total of units downstream more than 631	4 branching	7 branching	10 branching
CMY-Y102S-F	CMY-Y102L-F	CMY-Y202-F	CMY-Y302-F	CMY-Y104-E	CMY-Y107-E	CMY-Y1010-E

- ⑥ If the diameters of the branch piping of the designated refrigerant piping differs, use a pipe cutter to cut the connecting section and then use an adapter for connecting different diameters to connect the piping.
- ⑦ Always observe the restrictions on the refrigerant piping (such as rated length, the difference between high/low pressures, and piping diameter). Failure to do so can result in equipment failure or a decline in heating/cooling performance.
- ⑧ A second branch cannot be made after a header branch. (These are shown by X.)

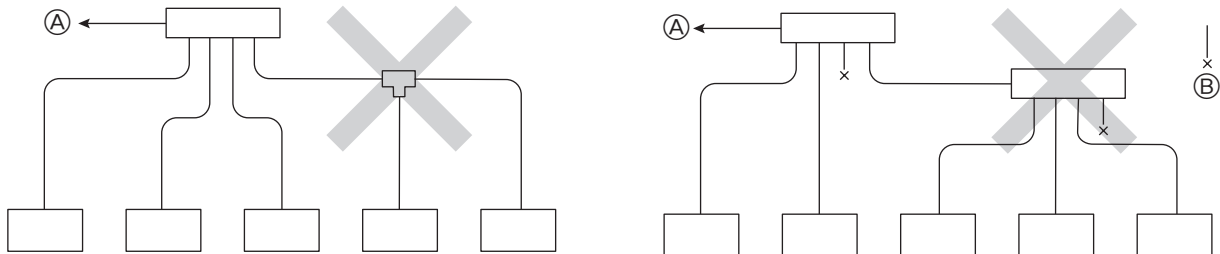

- Ⓐ To outdoor unit
- Ⓑ Capped piping

- ⑨ Always use good-quality materials for brazing.
- ⑩ The City Multi Series Super Y will stop due an abnormality due to excessive or insufficient coolant. At such a time, always properly charge the unit. When servicing, always check the notes concerning pipe length and amount of additional refrigerant at both locations, the refrigerant volume calculation table on the back of the service panel and the additional refrigerant section on the labels for the combined number of indoor units. (Refer to pages 13 to 14.)
- ⑪ **Never perform a pump down. This will damage the compressor.**
- ⑫ Never use refrigerant to perform an air purge. Always evacuate using a vacuum pump.
- ⑬ Always insulate the piping properly. Insufficient insulation will result in a decline in heating/cooling performance, water drops from condensation and other such problems. (Refer to pages 22 to 23.)
- ⑭ When connecting the refrigerant piping, make sure the ball valve of the outdoor unit is completely closed (the factory setting) and do not operate it until the refrigerant piping for the outdoor and indoor units has been connected, a refrigerant leakage test has been performed and the evacuation process has been completed.
- ⑮ Always use a non-oxidizing brazing material for brazing the parts. If a non-oxidizing brazing material is not used, it could cause clogging or damage to the compressor unit. (Details of the piping connections and valve operation can be found on pages 15 to 19.)

**⚠ Warning:**

**When installing and moving the air conditioner to another site, do not charge the it with a refrigerant different from the refrigerant (R22) specified on the unit.**

- If a different refrigerant or air is mixed with the original refrigerant, the refrigerant cycle may malfunction and the unit may be damaged.

## 10.2. Refrigerant piping system

### Line-branch method Connection examples (connecting to six indoor units)

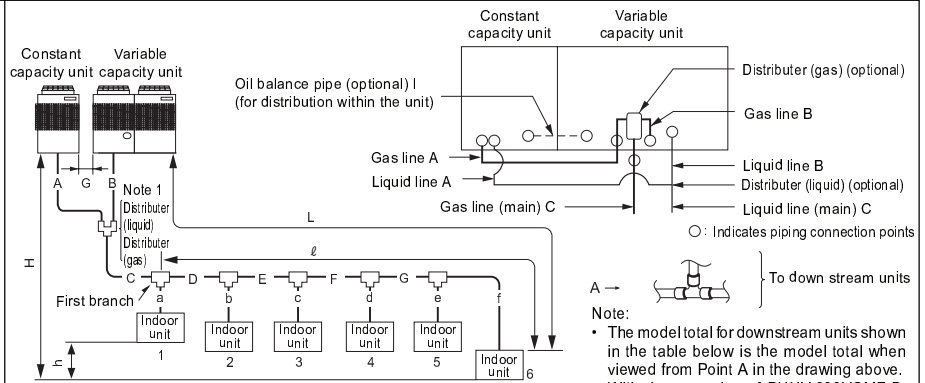

Note 1: Because it is built into the variable capacity unit, B is used to carry liquid only. Set the constant capacity unit and variable capacity unit in accordance with the G dimension given in the figure above (G = 0.01 m).

Permissible length	Indoor side	Item		Piping components	Tolerance
		Total piping length		A+B+C+D+E+F+G+a+b+c+d+e+f	
Farthest piping length (L)		A (B)+C+D+E+F+G+f		100 m or less (Max. equivalent length 125 m)	
Farthest piping length after first branch (ℓ)		D+E+F+G+f		40 m or less	
Permissible length	Outdoor side	Oil balance pipe		I	The included oil balance pipe must be used. If any other piping is used, the length of the oil balance pipe must be no more than 3 m (max. equivalent length 4 m), and height from the bottom of the unit must be no more than 0.1 m.
		Distributor (liquid)/Variable capacity unit, Constant capacity unit		A, B (Liquid line)	4 m or less (Max. equivalent length 5 m)
		Distributor (gas)/Constant capacity unit		A (Gas line)	4 m or less (Max. equivalent length 5 m)
Permissible high/Low difference	Indoor/Outdoor	Outdoor upper	H	50 m or less	
		Outdoor lower	H	40 m or less	
	Indoor/Outdoor	h	15 m or less		
Variable capacity unit/Constant capacity unit		-		Must be installed on same frame, and there must be no high/low difference.	

■ **Selecting the refrigerant branch kit**  
Use the table to the right to make the selection based on the model total of indoor units downstream from the branch section.

Select the branch kit, sold separately, from the table below. (Each kit contains a refrigerant and gas piping set.)

Downstream unit model total	Branch kit model
160 or less	CMY-Y102S-F
161 to 330	CMY-Y102L-F
331 to 630	CMY-Y202-F
631 or more	CMY-Y302-F

### ■ Select each section of refrigerant piping

- Section from outdoor unit to first branch (C)
  - Sections from branch to indoor unit (a, b, c, d, e, f)
  - Section from branch to branch (D, E, F, G)
- Each section of piping

Select the size from the table to the right.

(1) Refrigerant piping diameter in section from outdoor unit to first branch (outdoor unit piping diameter)

Model	Piping diameter (mm)	
	Liquid line	Gas line
PUHY-600YSMF-B	ø19.05	ø38.1
PUHY-650YSMF-B	ø19.05	ø44.45
PUHY-700YSMF-B	ø19.05	ø44.45
PUHY-750YSMF-B	ø19.05	ø44.45

(2) Refrigerant piping diameter in section from branch to indoor unit (indoor unit piping diameter)

Model number	Piping diameter (mm)	
	Liquid line	Gas line
20 · 25 · 32 · 40	ø6.35	ø12.7
	ø9.52	ø15.88
50 · 63 · 71 · 80	ø9.52	ø15.88
	ø19.05	ø25.4
100 · 125 · 140	ø12.7	ø25.4
	ø12.7	ø28.58
200	ø12.7	ø28.58
	ø12.7	ø28.58
250	ø12.7	ø28.58
	ø12.7	ø28.58

(3) Refrigerant piping diameter in section from branch to branch

Downstream unit model total	Liquid line (mm)	Gas line (mm)
80 or less	ø9.52	ø15.88
81 to 160	ø12.7	ø19.05
161 to 330	ø12.7	ø25.4
331 to 480	ø15.88	ø31.75
481 or more	ø15.88	ø38.1
631 or more	ø19.05	ø44.45

(kg)			
Variable capacity unit		Constant capacity unit	
400	500	200	250
16	22	6.5	8.5

### ■ Additional refrigerant charge

The outdoor unit is charged with refrigerant at the time of shipping according to the chart above. As this charge does not include the amount needed for extended piping, additional charging for each refrigerant line will be required on site. In order that future servicing may be properly provided, always keep a record of the size and length of each refrigerant line and the amount of additional charge by writing it in the space provided on the outdoor unit.

### ■ Calculation of additional refrigerant charge

- Calculate the amount of additional charge based on the length of the piping extension and the size of the refrigerant line.
- Use the table to the right as guide to calculating the amount of additional charging and charge the system according.
- If the calculation results in a fraction of less than 0.1 kg, round up to the next 0.1 kg. For example, if the result of the calculation was 23.28 kg, round the result up to 23.3 kg.
- If the total amount of refrigerant including the amount of refrigerant sealed in the outdoor unit when shipped from the factor plus additional refrigerant for extension piping exceeds 73 kg, use 73 kg as the total amount of refrigerant. Amount of refrigerant when shipped from factory + added refrigerant ≤ 73 kg.

<Additional charge>

Liquid pipe size total length of ø19.05 × 0.29	Liquid pipe size total length of ø15.88 × 0.25	Liquid pipe size total length of ø12.7 × 0.12	Liquid pipe size total length of ø9.52 × 0.06	Liquid pipe size total length of ø6.35 × 0.024	+	α
(m) × 0.29 (kg/m)	(m) × 0.25 (kg/m)	(m) × 0.12 (kg/m)	(m) × 0.06 (kg/m)	(m) × 0.024 (kg/m)	+	

<Example> Indoor 1: 125 A: ø12.7 3 m a: ø9.52 15 m  
 2: 125 B: ø15.88 1 m b: ø9.52 15 m  
 3: 125 C: ø19.05 40 m c: ø9.52 10 m  
 4: 125 D: ø15.88 10 m d: ø9.52 5 m  
 5: 100 E: ø15.88 5 m e: ø9.52 5 m  
 6: 40 F: ø12.7 5 m f: ø6.35 5 m  
 G: ø12.7 5 m

At the conditions below:

The total length of each liquid line is as follows:

ø19.05: C = 40 m  
 ø15.88: B + D + E = 1 + 10 + 5 = 16 m  
 ø12.7 : A + F + G = 3 + 5 + 5 = 13 m  
 ø9.52 : a + b + c + d + e = 50 m  
 ø6.35 : f = 5 m

Therefore,  
 <Calculation example>  
 Additional

refrigerant charge = 40 × 0.29 + 16 × 0.25 + 13 × 0.12 + 50 × 0.06 + 5 × 0.024 + 3.0 = 23.3 kg

Value of α

Total capacity of connecting indoor units to Model 80	α
Models 81 to 160	1.0 kg
Models 161 to 330	1.5 kg
Models 331 to 480	2.0 kg
Models 481 to 630	2.5 kg
Models 631 or more	3.0 kg

**Multiple line/header**  
Connection examples  
(connecting to six indoor units)

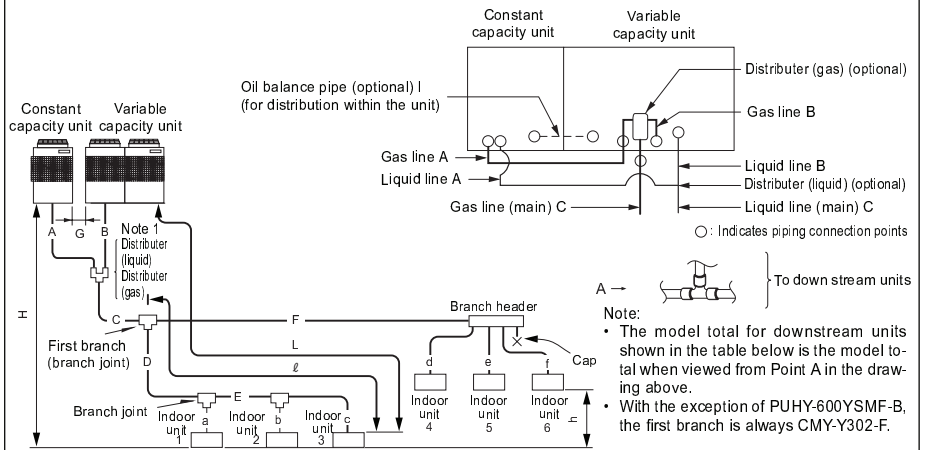

Note 1: Because it is built into the variable capacity unit, B is used to carry liquid only. Set the constant capacity unit and variable capacity unit in accordance with the G dimension given in the figure above (G = 0.01 m).

Permissible length	Indoor side	Item		Piping components	Tolerance
		Outdoor side	Total piping length	A+B+C+D+E+F+a+b+c+d+e+f	
Permissible high/Low difference	Indoor/Outdoor	Farthest piping length (L)	A (B)+C+D+E+c		100 m or less (Max. equivalent length 125 m)
		Farthest piping length after first branch (ℓ)	D+E+c		40 m or less
		Oil balance pipe	I		The included oil balance pipe must be used. If any other piping is used, the length of the oil balance pipe must be no more than 3 m (max. equivalent length 4 m), and height from the bottom of the unit must be no more than 0.1 m.
Permissible high/Low difference	Indoor/Outdoor	Distributor (liquid)/Variable capacity unit, Constant capacity unit	A, B (Liquid line)		4 m or less (Max. equivalent length 5 m)
		Distributor (gas)/Constant capacity unit	A (Gas line)		4 m or less (Max. equivalent length 5 m)
	Outdoor upper	H		50 m or less	
	Outdoor lower	H		40 m or less	
Permissible high/Low difference	Indoor/Outdoor	Variable capacity unit/Constant capacity unit	h		15 m or less
		Variable capacity unit/Constant capacity unit	-		Must be installed on same frame, and there must be no high/low difference.

**Selecting the refrigerant branch kit**  
Use the table to the right to make the selection based on the model total of indoor units downstream from the branch section or on the number of indoor units to be connected on the header branch.

Select the branch kit, sold separately, from the table below. (Each kit contains a refrigerant and gas piping set.)

Line branching				Header branching		
Total of units downstream less than 160	Total of units downstream 161 to 330	Total of units downstream 331 to 630	Total of units downstream more than 631	4 branching header	7 branching header	10 branching header
CMY-Y102S-C	CMY-Y102L-C	CMY-Y202-C	CMY-Y302-C	CMY-Y104	CMY-Y107	CMY-Y1010

**Select each section of refrigerant piping**

(1) Section from outdoor unit to first branch (C)  
 (2) Sections from branch to indoor unit (a, b, c, d, e, f)  
 (3) Section from branch to branch (D, E, F)

Each section of piping

Select the size from the table to the right.

(1) Refrigerant piping diameter in section from outdoor unit to first branch (outdoor unit piping diameter)

Model	Piping diameter (mm)	
	Liquid line	Gas line
PUHY-600YSMF-B	ø19.05	ø38.1
PUHY-650YSMF-B	ø19.05	ø44.45
PUHY-700YSMF-B	ø19.05	ø44.45
PUHY-750YSMF-B	ø19.05	ø44.45

(2) Refrigerant piping diameter in section from branch to indoor unit (indoor unit piping diameter)

Model number	Piping diameter (mm)	
	Liquid line	Gas line
20 · 25 · 32 · 40	ø6.35	ø12.7
	ø9.52	ø15.88
50 · 63 · 71 · 80	ø9.52	ø19.05
	ø12.7	ø25.4
100 · 125 · 140	ø12.7	ø28.58
	ø15.88	ø38.1
200	ø12.7	ø44.45
	ø15.88	ø50.8
250	ø12.7	ø57.15
	ø15.88	ø63.5

(3) Refrigerant piping diameter in section from branch to branch

Downstream unit model total	Liquid line (mm)	Gas line (mm)
80 or less	ø9.52	ø15.88
81 to 160	ø12.7	ø19.05
161 to 330	ø12.7	ø25.4
331 to 480	ø15.88	ø31.75
481 to 630	ø15.88	ø38.1
631 or more	ø19.05	ø44.45

(kg)			
Variable capacity unit		Constant capacity unit	
400	500	200	250
16	22	6.5	8.5

**Additional refrigerant charge**  
The outdoor unit is charged with refrigerant at the time of shipping according to the chart above. As this charge does not include the amount needed for extended piping, additional charging for each refrigerant line will be required on site. In order that future servicing may be properly provided, always keep a record of the size and length of each refrigerant line and the amount of additional charge by writing it in the space provided on the outdoor unit.

**Calculation of additional refrigerant charge**

- Calculate the amount of additional charge based on the length of the piping extension and the size of the refrigerant line.
- Use the table to the right as guide to calculating the amount of additional charging and charge the system according.
- If the calculation results in a fraction of less than 0.1 kg, round up to the next 0.1 kg. For example, if the result of the calculation was 20.03 kg, round the result up to 20.1 kg.
- If the total amount of refrigerant including the amount of refrigerant sealed in the outdoor unit when shipped from the factor plus additional refrigerant for extension piping exceeds 73 kg, use 73 kg as the total amount of refrigerant. Amount of refrigerant when shipped from factory + added refrigerant ≤ 73 kg.

<Additional charge>

Liquid pipe size total length of ø19.05 × 0.29	+	Liquid pipe size total length of ø15.88 × 0.25	+	Liquid pipe size total length of ø12.7 × 0.12	+	Liquid pipe size total length of ø9.52 × 0.06	+	Liquid pipe size total length of ø6.35 × 0.024	+ α
(m) × 0.29 (kg/m)		(m) × 0.25 (kg/m)		(m) × 0.12 (kg/m)		(m) × 0.06 (kg/m)		(m) × 0.024 (kg/m)	

<Example> Indoor 1: 125 A: ø12.7 3 m a: ø9.52 10 m  
 2: 125 B: ø15.88 1 m b: ø9.52 5 m  
 3: 125 C: ø19.05 30 m c: ø9.52 5 m  
 4: 125 D: ø15.88 10 m d: ø9.52 10 m  
 5: 100 E: ø12.7 5 m e: ø9.52 15 m  
 6: 40 F: ø12.7 15 m f: ø6.35 5 m

The total length of each liquid line is as follows:  
 ø19.05: C = 30 m  
 ø15.88: B + D = 1 + 10 = 11 m  
 ø12.7 : A + E + F = 3 + 5 + 15 = 23 m  
 ø9.52 : a + b + c + d + e = 10 + 5 + 5 + 10 + 15 = 45 m  
 ø6.35 : f = 5 m  
 Therefore,  
 <Calculation example>  
 Additional refrigerant charge = 30 × 0.29 + 11 × 0.25 + 23 × 0.12 + 45 × 0.06 + 5 × 0.024 + 3.0 = 20.1 kg

Value of α

Total capacity of connecting indoor units	α
to Model 80	1.0 kg
Models 81 to 160	1.5 kg
Models 161 to 330	2.0 kg
Models 331 to 480	2.5 kg
Models 481 or more	3.0 kg

### 10.3. Precautions concerning piping connection and valve operation

<For variable capacity unit>

- Connect piping and operate valves exactly as described in the figure below.
- After performing the following distributor (gas) connection, remove the connecting pipe included with the gas ball valve of the variable capacity unit, and mount the distributor (gas) (optional).
  - ① When brazing the distributor (gas), braze it outside of the unit before mounting on the variable capacity unit.
  - ② During the time when removing the connecting pipe with flange, remove the seal attached on the back side of this sheet and paste it onto the flange surface of the ball valve to prevent the entry of dust into the valve.
  - ③ The refrigerant circuit is closed with a round, close-packed packing at the shipment to prevent gas leak between flanges. As no operation can be done under this state, be sure replace the packing with the hollow packing attached at the piping connection.
  - ④ At the mounting of the hollow packing, wipe off dust attached on the flange sheet surface and the packing. Coat refrigerating machine oil onto both surfaces of the packing.
- After evacuation and refrigerant charge, ensure that the handle is fully open. If operating with the valve closed, abnormal pressure will be imparted to the high- or low-pressure side of the refrigerant circuit, or a shortage of oil in the compressor may occur due to lack of oil flow between units, giving damage to the compressor, four-way valve, etc.
- For evacuating, be sure to provide an oil balance pipe between the variable capacity and constant capacity units.
- Determine the amount of additional refrigerant charge by using the formula, and charge refrigerant additionally through the service port after completing piping connection work.
- After completing work, shut the service port and cap tightly so that gas leaking does not occur.
- Connect ball valve piping in the order of (oil balance) → (liquid side) → (gas side).

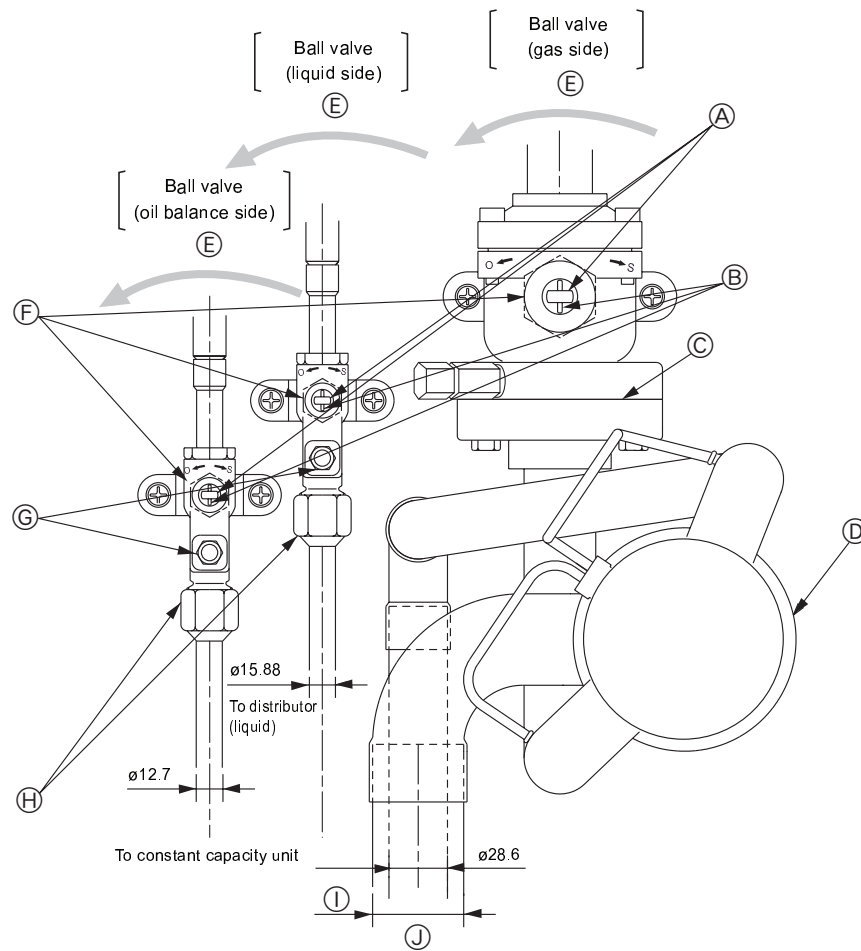
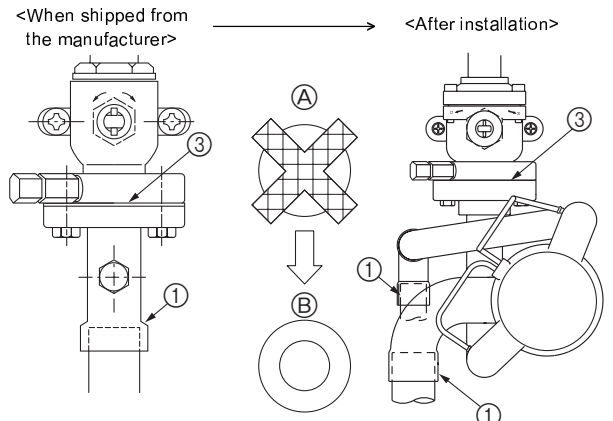

#### ⚠ Warning:

**Braze the distributor (gas) outside the unit, before mounting distributor (gas)\* to ball valve of the variable capacity unit.**

- If brazed while mounted, the ball valve is heated and could result in cracking or gas leaks. The wiring inside the unit could also be burned.

<For constant capacity unit>

- Connect piping and operate valves exactly as described in the figure below.
- Gas side connecting piping is already assembled when the equipment is shipped. (See figure on right.)
- ① When brazing to connecting pipe with flange, remove the connecting pipe with flange from the ball valve, and braze at the outside of the unit.
- ② During the time when removing the connecting pipe with flange, remove the seal attached on the back side of this sheet and paste it onto the flange surface of the ball valve to prevent the entry of dust into the valve.
- ③ The refrigerant circuit is closed with a round, close-packed packing at the shipment to prevent gas leak between flanges. As no operation can be done under this state, be sure to replace the packing with the hollow packing attached at the piping connection.
- ④ At the mounting of the hollow packing, wipe off dust attached on the flange sheet surface and the packing. Coat refrigerating machine oil onto both surfaces of the packing.

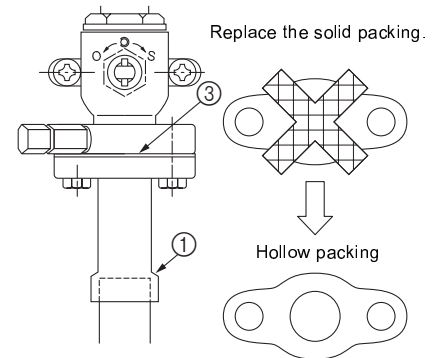

- After evacuation and refrigerant charge, ensure that the handle is fully open. If operating with the valve closed, abnormal pressure will be imparted to the high- or low-pressure side of the refrigerant circuit, or a shortage of oil in the compressor may occur due to lack of oil flow between units, giving damage to the compressor, four-way valve, etc.
- For evacuating, be sure to provide an oil balance pipe between the variable capacity and constant capacity units.
- Determine the amount of additional refrigerant charge by using the formula, and charge refrigerant additionally through the service port after completing piping connection work.
- After completing work, shut the service port and cap tightly so that gas leaking does not occur.

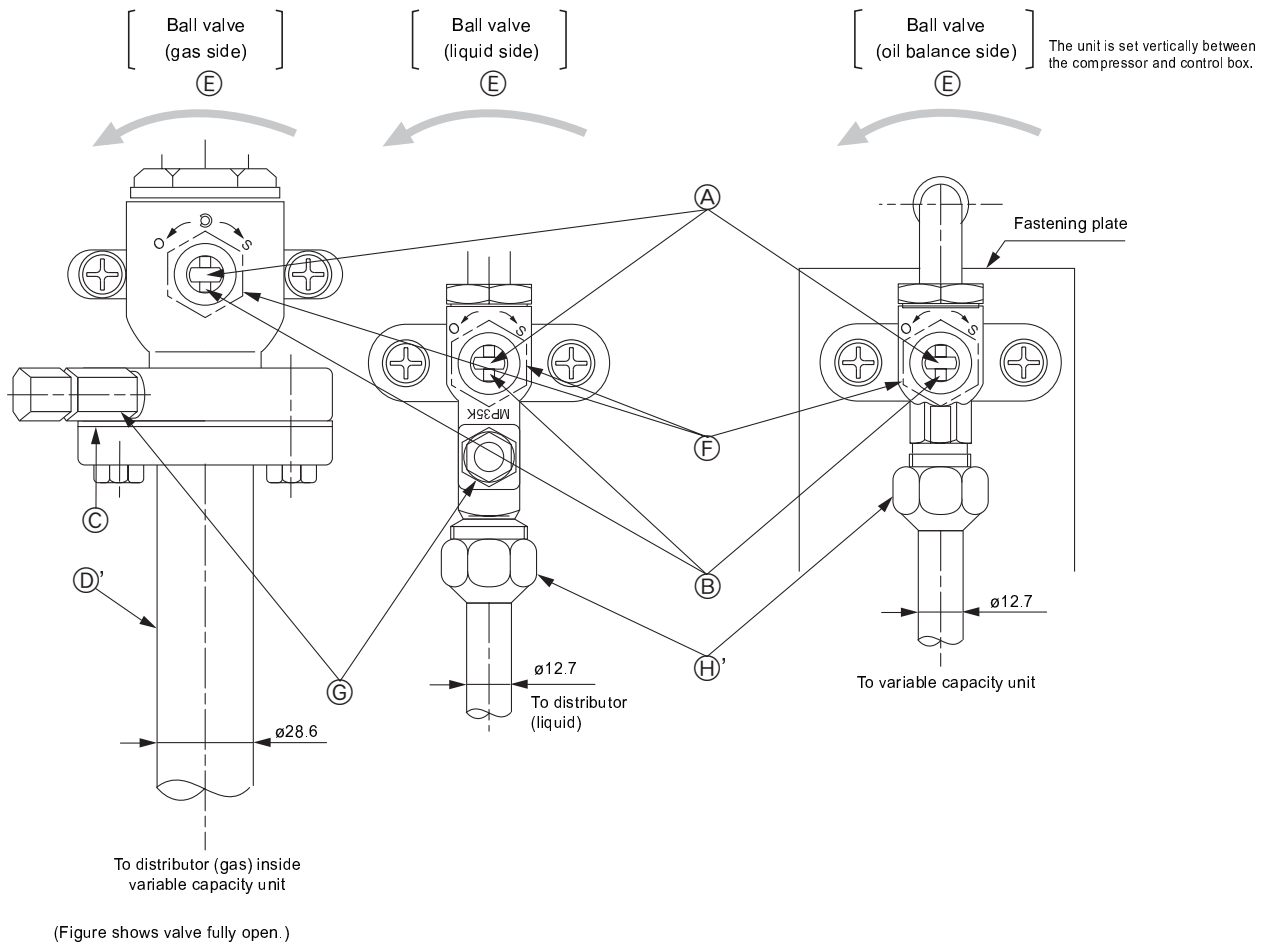

**⚠ Warning:**

**Be sure to remove the connecting pipe from the ball valve, and braze it outside the unit.**

- If brazed while mounted, the ball valve is heated and could result in cracking or gas leaks. The wiring inside the unit could also be burned.



- Ⓐ Valve stem  
[Fully closed at the factory, when connecting the piping, when evacuating, and when charging additional refrigerant. Open fully after the operations above are completed.]
- Ⓑ Stopper pin [Prevents the valve stem from turning 90° or more.]
- Ⓒ Packing (accessory)
- Ⓓ Distributer (gas) (option)  
[Mount packing (accessory) securely to the valve flange so that gas does not leak. (Screw tightening torque: 43 N·m (430 kg·cm)) Apply a coat of refrigerating machine oil to both surfaces of the packing.]
- Ⓓ' Connecting pipe (accessory)  
[Use packing and securely install this pipe to the valve flange so that gas leakage will not occur. (Tightening torque: 25 N·m (250 kg·cm)) Coat both surfaces of the packing with refrigerator oil.]
- Ⓔ Open (operate slowly)
- Ⓕ Cap, copper packing  
[Remove the cap and operate the valve stem. Always reinstall the cap after operation is completed. (Valve stem cap tightening torque: 25 N·m (250 kg·cm) or more)]
- Ⓖ Service port  
[Use this port to evacuate the refrigerant piping and add an additional charge at the site.  
Open and close the port using a double-ended wrench.  
Always reinstall the cap after operation is completed. (Service port cap tightening torque: 14 N·m (140 kg·cm) or more)]
- Ⓗ Flare nut  
[Tightening torque: 80 N·m (800 kg·cm) ... liquid, 55 N·m (550 kg·cm) ... oil blance  
Loosen and tighten this nut using a double-ended wrench.  
Coat the flare contact surface with refrigerator oil.]
- Ⓗ' Flare nut  
[Tightening torque: 55 N·m (550 kg·cm)  
Use a double spanner to open and close. Apply a coat of refrigerating machine oil to the flare bonding surface.]
- ① ø38.1 (PUHY-600YSMF-B)  
ø44.5 (PUHY-650/700/750YSMF-B)
- ④ Field piping  
[Brazo to the connecting pipe. (When brazing, use unoxidized brazing.)]

Appropriate tightening torque by torque wrench

Copper pipe external dia. (mm)	Tightening torque (N·m) / (kg·cm)
ø6.35	14 to 18 / 140 to 180
ø9.52	35 to 42 / 350 to 420
ø12.7	50 to 57.5 / 500 to 575
ø15.88	75 to 80 / 750 to 800
ø19.05	100 to 140 / 1000 to 1400

Tightening angle standard

Pipe diameter (mm)	Tightening angle (°)
ø6.35, ø9.52	60 to 90
ø12.7, ø15.88	30 to 60
ø19.05	20 to 35

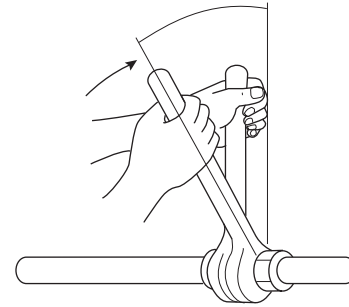

**Note:**

If a torque wrench is not available, use the following method as a standard.

When you tighten the flare nut with a wrench, you will reach a point where the tightening torque will abruptly increase. Turn the flare nut beyond this point by the angle shown in the table above.

**⚠ Caution:**

Always remove the connecting pipe from the ball valve and braze it outside the unit.

- Brazing the connecting pipe while it is installed will heat the ball valve and cause trouble or gas leakage. The piping, etc. inside the unit may also be burned.

## 10.4. Oil balance pipe connection method

- Oil balance piping can be taken out from the front, bottom or side of the unit (left side for the variable capacity unit, right side for the constant capacity unit).
- Connect piping and operate valves exactly as described below (for details, see item 10.3.).
  - After connecting oil balance pipe, be sure to evacuate using the service port of the variable capacity unit side valve.
  - After evacuating, be sure to fully open each valve stem. If you operate with the valve closed, a shortage of oil in the compressor may occur due to lack of oil flow between units, which could result in damage to the compressor.
  - After completing work, shut the cap of the service port and handle section tightly so that gas leaking does not occur.

### **Warning:**

Failure to connect the oil balance pipe will result in the compressor being damaged.

- Provide 10 mm of clearance between the variable capacity and constant capacity units. Position the variable capacity unit so that its front is facing on the right side and the constant capacity unit so that its front is facing on the left. Connect the oil balance pipe for the optional CMC-30A according to the following procedure.
  - Open the knock-out holes of the left side panel for the variable capacity unit, and the right side panel for the constant capacity unit.
  - After installing the units, flare-connect the piping included with the unit ( $\phi 12.7$ ).
  - Block the clearance between units with the 2 seals included with the constant capacity unit.

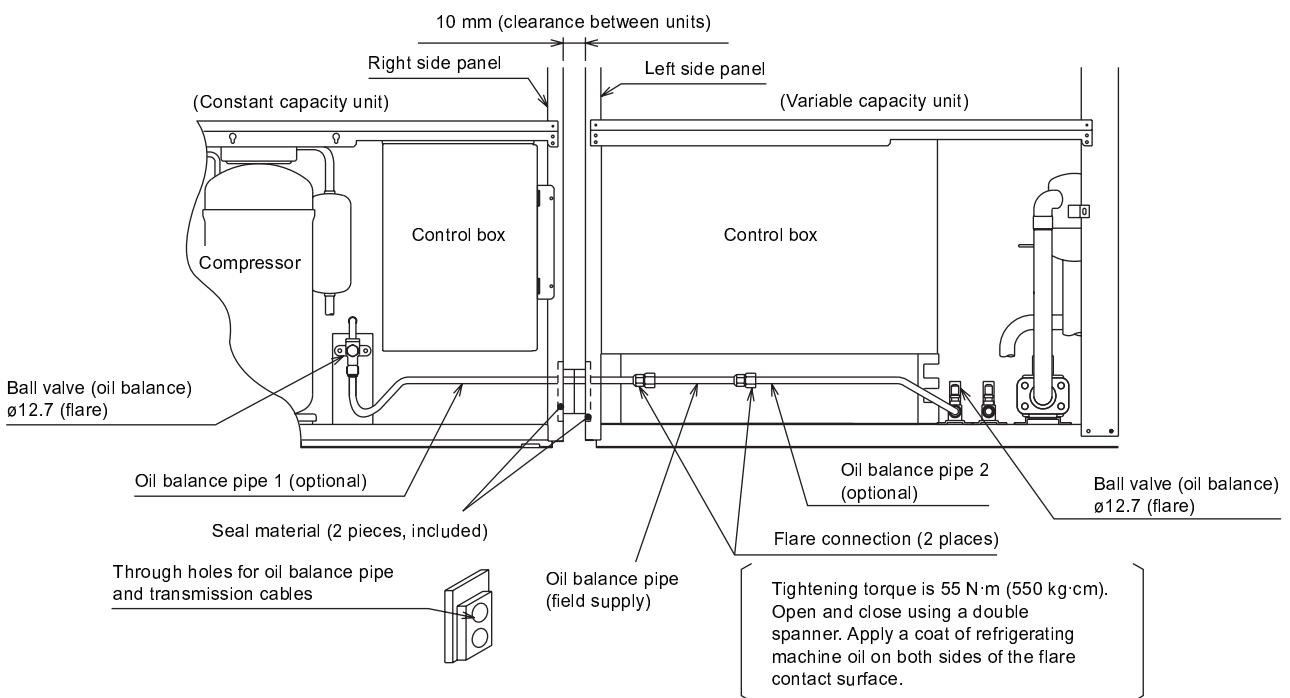

- If the oil balance piping for the constant capacity unit from the front of the unit is taken out, bend the piping as shown in the figure below. (When doing so, be careful not to let the piping touch the compressor or other parts.)

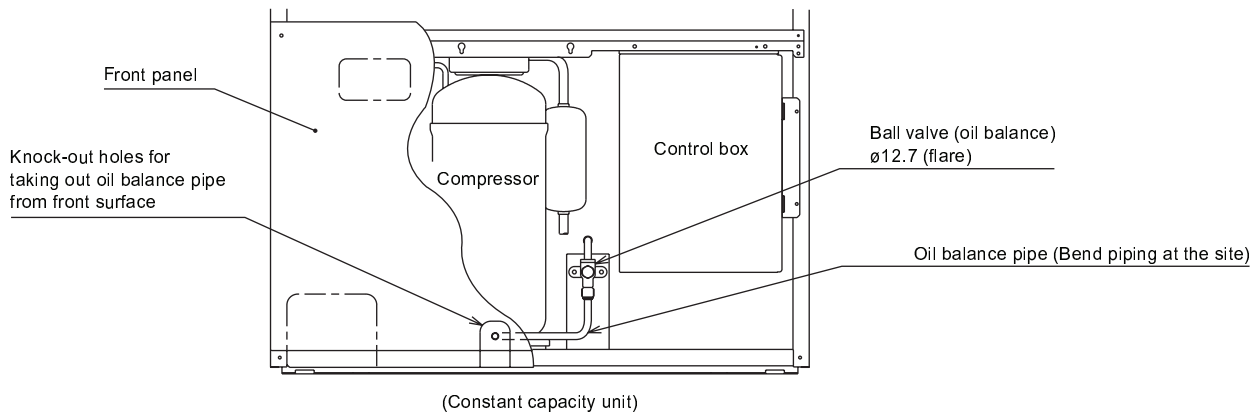

## 10.5. Distributor (gas) connection method

### ■ Taking out piping from the front direction

- (1) Remove the copper cap and rubber packing attached to the piping and flange of the distributor (gas) (optional).
- (2) Assemble outside the unit with the elbow (⑧) in the specified shape and braze. (see Fig. 1.)  
For the 600 type, braze the connecting pipe (⑦) also.

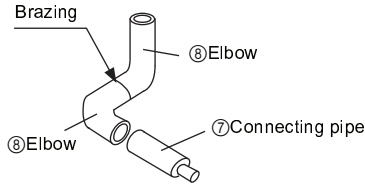

Fig. 1

- (3) Braze the connecting pipe (④) and piping assembled in step (2) to the distributor (gas) so that the connecting pipe is attached as shown in Fig. 2. For assembly procedure, see Fig. 3. When brazing piping, cool the brazed portion of the distributor side piping with a dampened waste cloth to prevent heating by brazing.

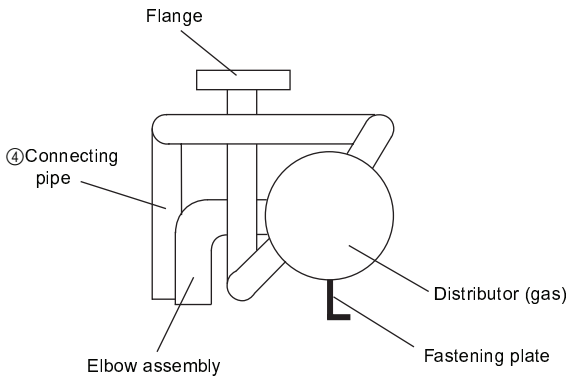

Fig. 2

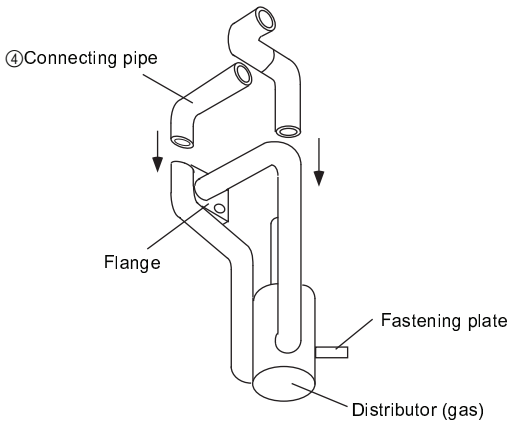

Fig. 3

- (4) Connect the  $\phi 12.7$  oil balance pipe to the ball valve of the variable capacity unit (oil balance) and constant capacity unit.
- (5) Connect the  $\phi 15.88$  piping branched by the distributor (liquid) to the ball valve of the variable capacity unit (liquid side).
- (6) Insert the distributor (gas) into the variable capacity unit and connect to the flange of the ball valve (gas side). (Use a socket wrench and socket wrench extension.) When doing so, be sure to mount the included packing between the ball valve (gas side) and flange of the distributor.
- (7) Fasten the plate of the distributor (gas) to the frame of the unit with screws.
- (8) Connect and braze the  $\phi 44.45$  ( $\phi 38.1$  for 600 type) gas piping (main pipe) and  $\phi 28.58$  gas pipe that connects the constant capacity unit with the distributor (gas).

### ■ Taking out piping in the downward direction

- (1) Remove the copper cap and rubber packing attached to the piping and flange of the distributor (gas) (optional).
- (2) Assemble outside the unit with the elbow (⑧), connecting pipe (⑦ for 600 type), or connecting pipe (⑥ for types other than 600) in the specified shape and braze. (see Fig. 4.)

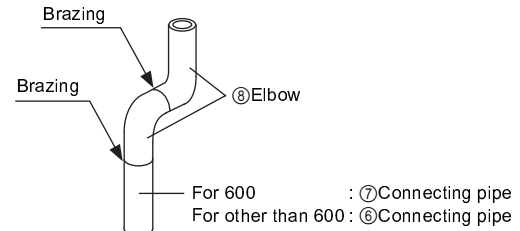

Fig. 4

- (3) Braze the connecting pipe (⑤) and connecting piping assembled in step (2) to the distributor (gas) outside the unit. For assembly procedure, see Fig. 5. When brazing piping, cool the brazed portion of the distributor side piping with a dampened waste cloth to prevent heating by brazing.

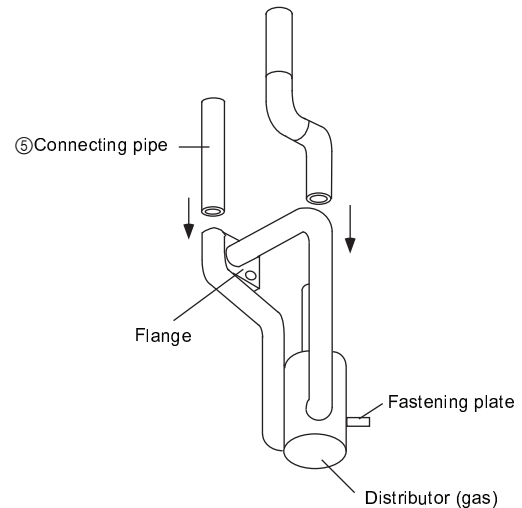

Fig. 5

The rest of the procedure is the same as for "Running piping from front direction".

### ⚠ Caution:

**When brazing, cool with a waste cloth dampened with water so that the flange and ends of the distributor side piping don't get heated.**  
- Part could be damaged if not cooled sufficiently.

## 10.6. How to install branch pipe

For detail, please observe the instruction manual attached to the optional refrigerant branch kit.

### ■ Joint

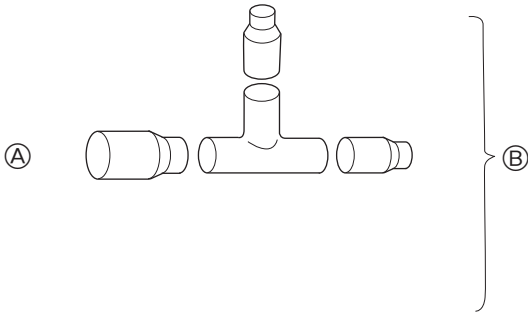

- Ⓐ To outdoor unit
- Ⓑ To branch piping or indoor unit

- Apart from the CMY-Y202-F and CMY-Y302-F gas side, there are no restrictions on the posture for attaching joints.
- Ensure that the branch pipes for the CMY-Y202-F and CMY-Y302-F gas side are attached horizontally or facing upwards (see the diagram below).

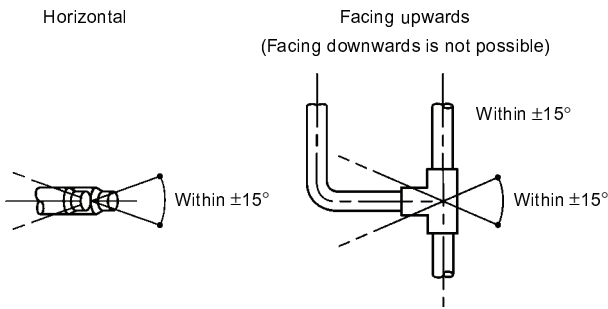

- There is no limitation on the joint mounting configuration.
- If the diameter of the refrigerant piping selected by the procedures described on pages 13 to 14 is different from the size of the joint, match the sizes using a deformed joint. The deformed joint is included with the kit.

### ■ Header

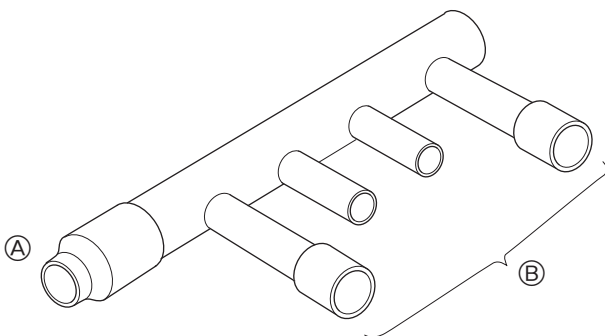

- Ⓐ To outdoor unit
- Ⓑ To indoor unit

- No restriction is applied to the mounting posture of the header.
- If the diameter of the refrigerant piping selected using the procedures described on pages 14 and the size of the joint is different, match the sizes using a deformed joint. The deformed joint is included with the kit.

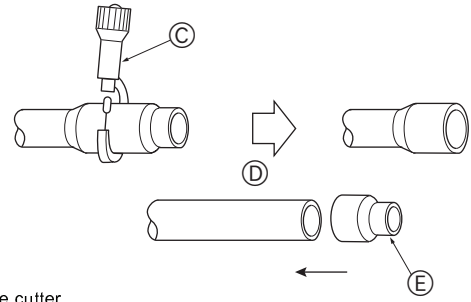

- Ⓒ Pipe cutter
- Ⓓ or
- Ⓔ Deformed joint

- When the number of pipes to be connected is smaller than the number of header branches, install a cap to the unconnected branches. The cap is included with the kit.

### ■ Distributer (liquid)

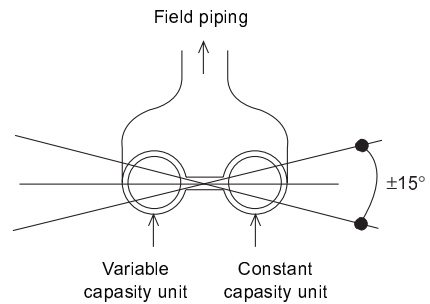

- Mount the distributor (liquid, optional CMC-30A) so that it is within  $\pm 15^\circ$  in relation to the horizontal plane (see figure above).

## 10.7. Airtight test and evacuation

### ① Airtight test

Airtight test should be made by pressurizing nitrogen gas to 3.0 MPa. For the test method, refer to the following figure. (Make a test with the ball valve closed. Be also sure to pressurize both liquid pipe and gas pipe.)

The test result can be judged good if the pressure has not been reduced after leaving for about one day after completion of nitrogen gas pressurization.

- Ⓐ Nitrogen gas
- Ⓑ To indoor unit
- Ⓒ System analyzer
- Ⓓ Lo knob
- Ⓔ Hi knob
- Ⓕ Ball valve
- Ⓖ Liquid pipe
- Ⓗ Gas pipe
- Ⓘ Outdoor unit
- ⓵ Service port

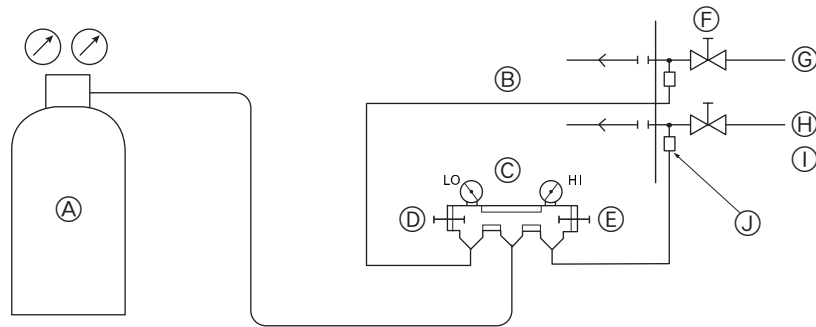

### ② Evacuation

Evacuation should be made from the service port provided on the outdoor unit's ball valve to the vacuum pump commonly used for both liquid pipe and gas pipe. (Make evacuation from both liquid pipe and gas pipe with the ball valve closed.)

Also evacuate the oil balance pipe that connects the variable capacity and constant capacity units with the oil balance ball valves of both units shut. Evacuate from the service port of the variable capacity unit ball valve with a vacuum pump.

\* Never perform air purging using refrigerant.

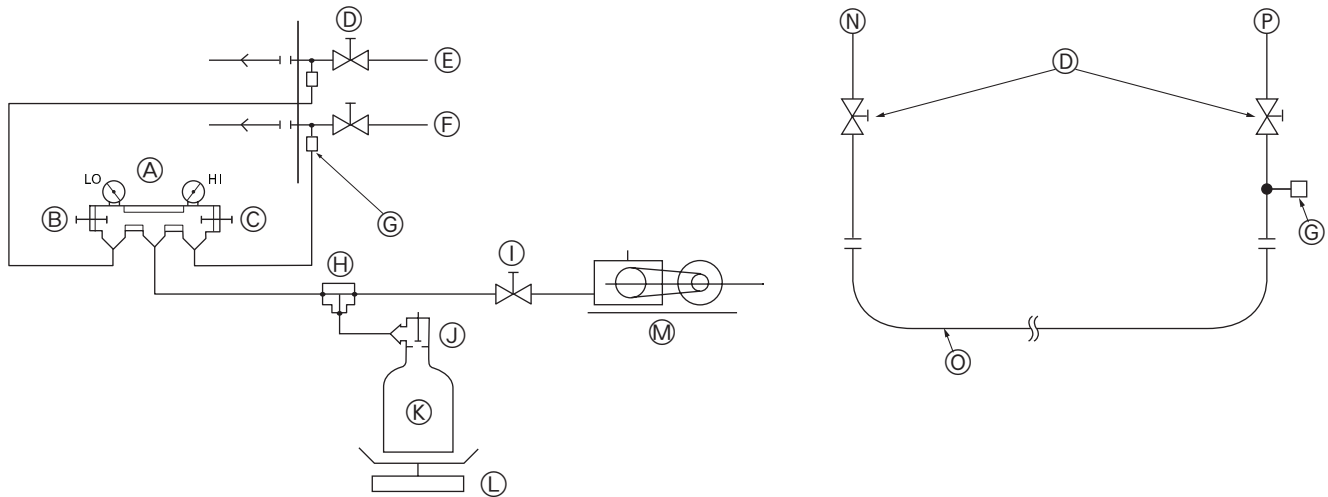

- Ⓐ System analyzer
- Ⓑ Lo Knob
- Ⓒ Hi Knob
- Ⓓ Ball valve
- Ⓔ Liquid pipe
- Ⓕ Gas pipe
- Ⓖ Service port
- Ⓗ Three-way joint
- Ⓘ Valve

- ⓵ Valve
- ⓷ Freon 22 cylinder
- ⓸ Scale
- Use a gravimeter. (One that can measure down to 0.1 kg.)  
If you are unable to prepare such a high-precision gravimeter, you may use a charge cylinder.
- ⓹ Vacuum pump
- ⓺ Constant capacity unit side
- ⓻ Oil balance pipe
- ⓼ Variable capacity unit side

**Note:**  
Always add an appropriate amount of refrigerant. (For the refrigerant additional charge, see pages 13 to 14.) Too much or too little refrigerant will cause trouble.

Note that it is not possible to determine if a correct amount is being used with the accumulator level (AL).

### ⚠ Warning:

When installing and moving the air conditioner to another site, do not charge it with a refrigerant different from the refrigerant (R22) specified on the unit.

- If a different refrigerant or air is mixed with the original refrigerant, the refrigerant cycle may malfunction and the unit may be damaged.

## 10.8. Thermal insulation of refrigerant piping

Be sure to give insulation work to refrigerant piping by covering liquid pipe and gas pipe separately with enough thickness heat-resistant polyethylene, so that no gap is observed in the joint between indoor unit and insulating material, and insulating materials themselves. When insulation work is insufficient, there is a possibility of condensation drip, etc. Pay special attention to insulation work to ceiling plenum.

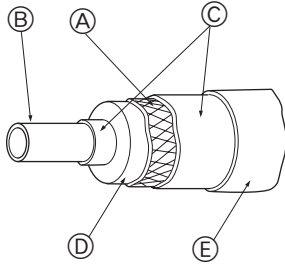

- Ⓐ Steel wire
- Ⓑ Piping
- Ⓒ Asphaltic oily mastic or asphalt
- Ⓓ Heat insulation material A
- Ⓔ Outer covering B

Heat insulation material A	Glass fiber + Steel wire	
	Adhesive + Heat - resistant polyethylene foam + Adhesive tape	
Outer covering B	Indoor	Vinyl tape
	Floor exposed	Water-proof hemp cloth + Bronze asphalt
	Outdoor	Water-proof hemp cloth + Zinc plate + Oily paint

**Note:**  
When using polyethylene cover as covering material, asphalt roofing shall not be required.

<p>Bad example</p>	<ul style="list-style-type: none"> <li>Do not insulate gas or low pressure pipe and liquid or high pressure pipe together.</li> </ul> <ul style="list-style-type: none"> <li>Ⓐ Liquid pipe</li> <li>Ⓑ Gas pipe</li> <li>Ⓒ Electric wire</li> <li>Ⓓ Finishing tape</li> <li>Ⓔ Insulating material</li> </ul>	<ul style="list-style-type: none"> <li>Be sure to fully insulate connecting portion.</li> </ul> <p>Ⓐ These parts are not insulated.</p>
<p>Good example</p>	<ul style="list-style-type: none"> <li>Ⓐ Liquid pipe</li> <li>Ⓑ Gas pipe</li> <li>Ⓒ Finishing tape</li> <li>Ⓓ Insulating material</li> </ul>	

**Note:**  
No heat insulation must be provided for electric wires.

## Penetrations

Inner wall (concealed)

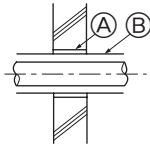

Outer wall

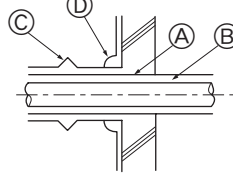

Outer wall (exposed)

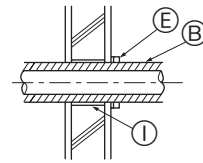

Floor (fireproofing)

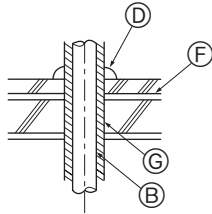

Roof pipe shaft

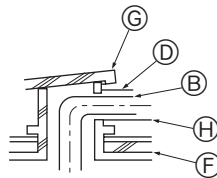

Penetrating portion on fire limit and boundary wall

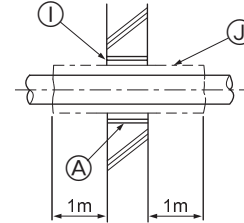

- (A) Sleeve
- (B) Heat insulating material
- (C) Lagging
- (D) Caulking material
- (E) Band
- (F) Waterproofing layer
- (G) Sleeve with edge
- (H) Lagging material

- (I) Mortar or other incombustible caulking
- (J) Incombustible heat insulation material

When filling a gap with mortar, cover the penetration part with steel plate so that the insulation material will not be caved in. For this part, use incombustible materials for both insulation and covering. (Vinyl covering should not be used.)

## Branch piping section

Insulate the header using the insulation material attached to the branch pipe kit as shown in the figure.

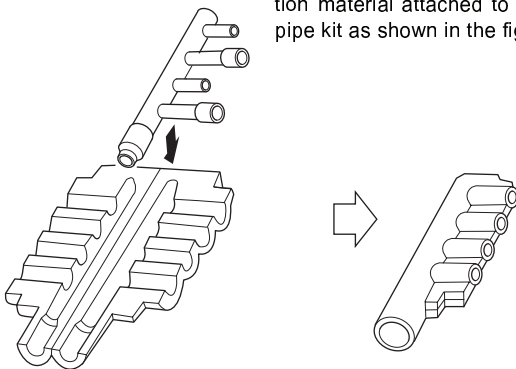

# 11. Electrical work

## 11.1. Caution

① Follow ordinance of your governmental organization for technical standard related to electrical equipment, wiring regulations and guidance of each electric power company.

**⚠ Warning:**

**Be sure to have authorized electric engineers do electric work using special circuits in accordance with regulations and this installation manual. If power supply circuit has a lack of capacity or electric work deficiency, it may cause an electric shock or fire.**

② Install the outdoor unit transmission line away from the power source wiring so that it is not affected by electric noise from the power source. (Do not run it through the same conduit.)

③ Be sure to provide designated grounding work to outdoor unit.

**⚠ Caution:**

**Be sure to put outdoor unit to earth. Do not connect earth line to any gas pipe, water pipe, lightning rod or telephone earth line. If earth is incomplete, it may cause an electric shock.**

④ Give some allowance to wiring for electrical part box of indoor and outdoor units, because the box is sometimes removed at the time of service work.

⑤ Never connect the main power source to terminal block of transmission line. If connected, electrical parts will be burnt out.

⑥ Use 2-core shield cable for transmission line (○ mark in the figure below). If transmission lines of different systems are wired with the same multiple-core cable, the resultant poor transmitting and receiving will cause erroneous operations (× mark in the figure below).

⑦ Only the transmission line specified should be connected to the terminal block for outdoor unit transmission.

(Transmission line to be connected with indoor unit: Terminal block TB3 for transmission line, Other: Terminal block TB7 for centralized control)  
Erroneous connection does not allow the system to operate.

⑧ In case to connect with the upper class controller or to conduct group operation in different refrigerant systems, the control line for transmission is required between the outdoor units each other.

Connect this control line between the terminal blocks for centralized control. (2-wire line with no polarity)

When conducting group operation in different refrigerant systems without connecting to the upper class controller, replace the insertion of the short circuit connector from CN41 of one outdoor unit to CN40.

⑨ Group is set by operating the remote controller.

⑩ Caution! If the electrical wiring connections (L1, L2, L3, N ⊥) are made incorrectly, damage to the unit could result.

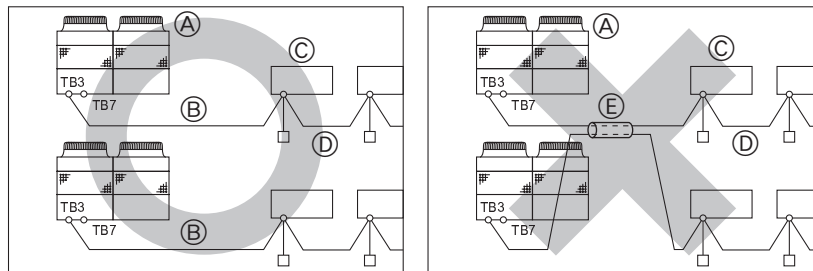

TB3: Transmission line terminal board, TB7: Central control line terminal board

- Ⓐ Outdoor unit
- Ⓑ 2-core cable
- Ⓒ Indoor unit
- Ⓓ Remote controller
- Ⓔ Multi-core cable



## 11.2. Control box and connecting position of wiring

### a. Variable capacity unit

1. Remove the total of six screws at the top and bottom, and remove the service panel by pulling it forward. (See the figure below.)

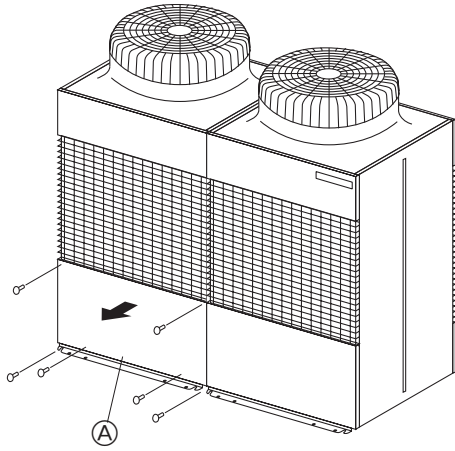

A Service panel

2. Remove the two screws on the left and right-hand of the base of the control box and pull the overall cover downwards to detach it. (A diagram with the control box cover removed is shown below.)

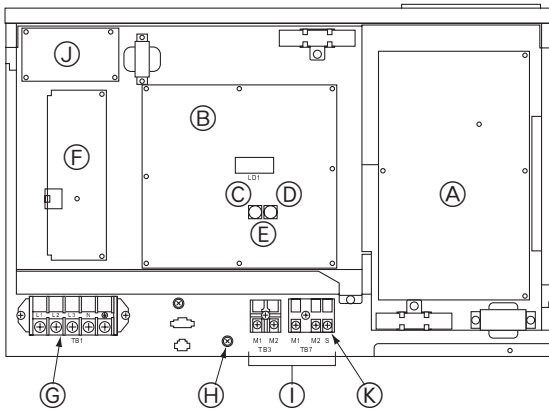

- A INV board
- B MAIN board
- C Ten position
- D One position
- E Address switch
- F FANCON board
- G Power source
- H Shield screw
- I Transmission line
- J RELAY board
- K Shield terminal (S)

3. Connect indoor and outdoor units through the terminal block for transmission lines (TB3). Outdoor units and connections to central control systems go through the terminal block for centralized control (TB7). When making an indoor/outdoor connection with shielded wiring, connect the shield ground to the shield screw. When making a central control system connection with shielded wiring, use the terminal block for centralized control (TB7). When the CN41 power supply connector of an outdoor unit has been replaced with a CN40, the shield terminal (S) for centralized control (TB7) should also be connected to the shield screw.

### 4. How to use the conduit mounting plate

- (1) Conduit mounting plates (ø46, ø53, ø62) are being provided. Select conduit mounting plate based on the outside diameter of conduit to be used and mount it as shown in the figure.
- (2) Fix power source wiring to control box by using buffer bushing for tensile force (PG connection or the like).

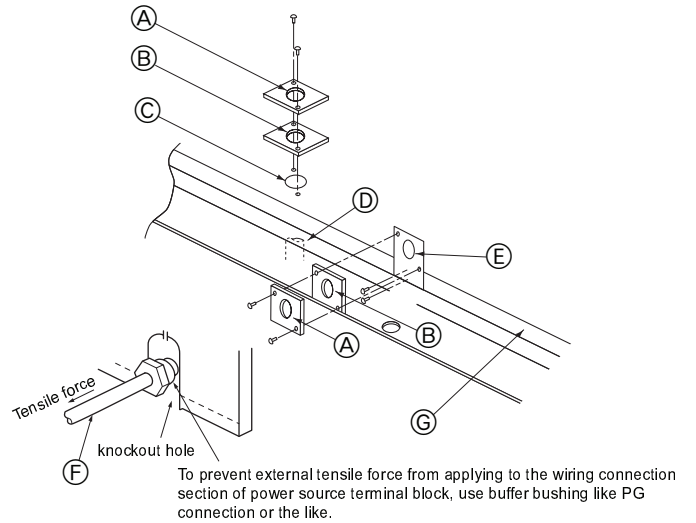

- A ø46 mounting hole
- B ø53 mounting hole
- C ø62 knockout hole
- D For the connection of conduit at bottom
- E ø62 mounting hole
- F For the connection of conduit at front
- G The front of outdoor unit

### b. Constant capacity unit

1. The service panel is removed by removing the six screws at the top and bottom and pulling it forward. (See figure below.)

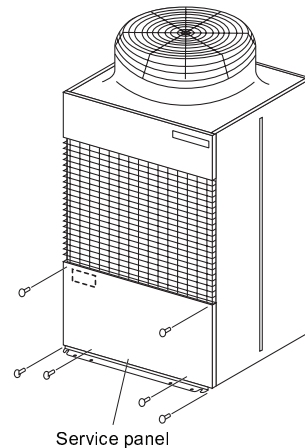

Service panel

2. The control box cover is removed by removing the 2 screws and pulling downward. (The control box with the cover removed is shown in the figure below.)

3. Method of using conduit mounting plate

The equipment includes conduit mounting plates (ø27, ø33, ø40). Select the mounting plate according to the diameter of the conduit used, and mount as shown in the figure below.

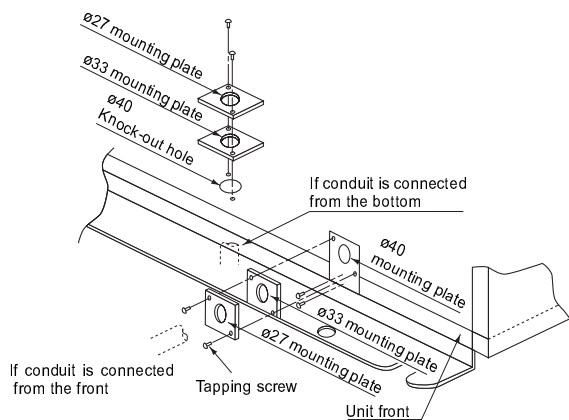

4. Wiring connection

Connect indoor unit crossover cables of the transmission cables terminal block (TB3) of the variable capacity unit to the transmission cables terminal block (TB3). When making an indoor/outdoor connection with shielded wiring, connect the shield ground to the shield terminal (TB3).

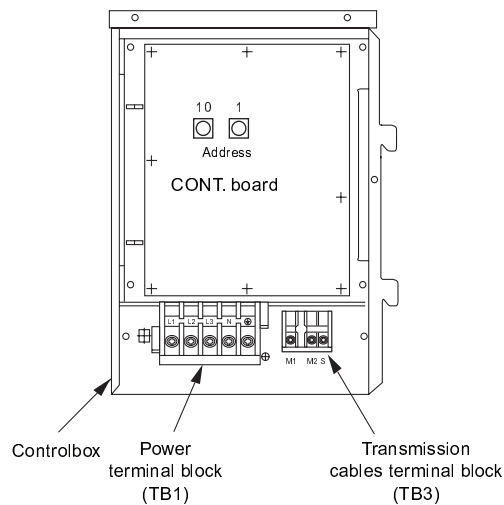

c. Transmission booster (optional)

(For details, see item 11.3. "Wiring transmission cables")

- Connect 220/230/240 VAC to L/N of power terminal block (TB1).
- Connect the ground to the ⊕ terminal of power terminal block (TB1).
- Connect the outdoor unit side transmission cables to A/B of transmission cables terminal block 1 (TB2).
- Connect the outdoor unit side shield to S of transmission cables terminal block 1 (TB2).
- Connect additional indoor unit side transmission cables to A/B of transmission cables terminal block 2 (TB3).
- Connect additional indoor unit side shield to S of transmission cables terminal block 2 (TB3).

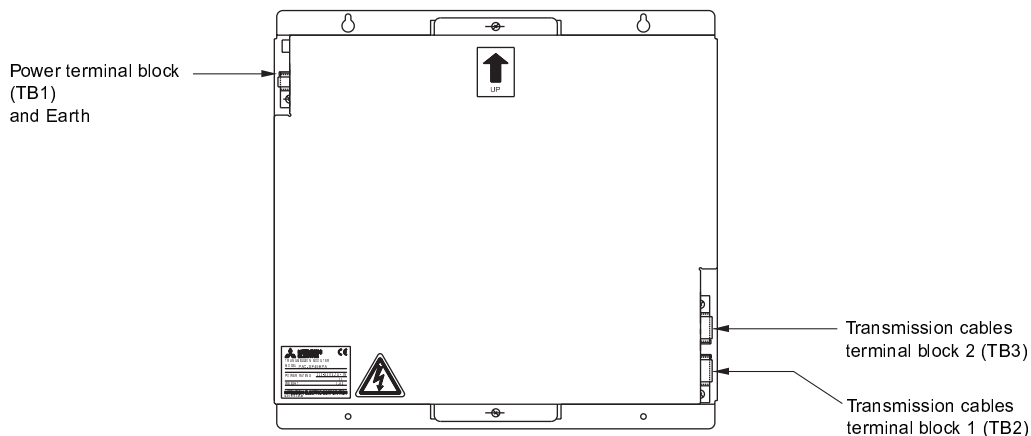

## 11.3. Wiring transmission cables

Wiring method, address setting method and permissible wiring length differ according to and whether or not you are using transmission booster. Check permissible wiring length before wiring.

A may be required depending on the number of indoor units.

Item ④ "Wiring examples" gives typical wiring examples (a to c).

- a. System using remote controller (1 outdoor unit)
- b. System using remote controller (system operated as a group among multiple refrigerant systems)
- c. System using power supply extension unit for transmission booster (combination of systems a to b)

### ① Connecting a transmission booster

A transmission booster (RP) is required when the number of connected indoor unit models in a cooling system exceeds the number of models specified in the chart below.

\* The maximum number of units that can be controlled is determined by the indoor unit model, the type of remote controller and their capabilities.

(*1) Capability of the connected indoor units	Remote controller type  Number of connected indoor units that can be connected without a RP	Remote controller PAR-F 25MA	
		Prior to Ver. E	After Ver. F
	200 or lower	16 (32)	20 (40)
	200 or higher	16 (32)	16 (32)

The number of indoor units and the total number of remote controllers is displayed within the parenthesis ( ).

\*1 If even one unit that is higher than 200 exists in the cooling system, the maximum capacity will be "200 or higher".

### ② Name, code and possible unit connections

	Name	Code	Possible unit connections
Outdoor unit	Variable capacity unit controller	OC	—
	Constant capacity unit controller	OS	1 unit per 1 OC
Indoor unit	Indoor unit controller	IC	2 to 32 units per 1 OC (*1)
Remote controller	Remote controller (*1)	RC	2 units maximum per group
Other	Transmission booster unit	RP	0 to 1 unit per 1 OC (*1)

\*1 A transmission booster (RP) may be required depending on the number of connected indoor unit controllers.

### ③ Types of control cables

#### (1) Wiring transmission cables

- Types of transmission cables  
Shielding wire CVVS or CPEVS
- Cable diameter  
More than 1.25 mm<sup>2</sup>
- Maximum wiring length within 200 m

#### (2) Remote control cables

Kind of remote control cable	2-core cable (unshielded)
Cable diameter	0.5 to 0.75 mm <sup>2</sup>
Remarks	When 10 m is exceeded, use cable with the same specifications as (1) Transmission line wiring.

### ④ Wiring examples

Typical wiring examples are shown on pages 28 to 32 (Wiring examples A to C).

Example of control line wiring	Wiring method, address setting																					
<p>1) Standard</p> <p>• One remote control unit for each indoor unit. Within ( ): Address</p>	<p>a. Run the wire to terminals M1 and M2 the variable capacity unit (OC) transmission line terminal block (TB3) and to terminals M1 and M2 on the constant capacity unit (OS) transmission line terminal block (TB3) as well as to the terminals M1 and M2 of the transmission line terminal block (TB5) of each indoor unit (IC). (Two-wire, no polarity) Also, run the shielded ground wire to the ground terminal ⊕ of the variable capacity unit, the S terminal of the constant capacity unit (TB3), and the S terminal of each indoor unit (TB5).</p> <p>b. Connect the wires to terminals M1 and M2 of the transmission line terminal block (TB5) in each indoor unit (IC) and connect them to the remote control (RC) terminal block (TB6).</p> <p>c. Set the address setting switch as shown in the following table.</p> <table border="1" style="width:100%; border-collapse: collapse;"> <thead> <tr> <th>Unit</th> <th>Range</th> <th>Setting method</th> </tr> </thead> <tbody> <tr> <td>Indoor unit</td> <td>01 to 50</td> <td>—</td> </tr> <tr> <td>Remote control</td> <td>101 to 150 <small>Note 2</small></td> <td>Indoor unit address + 100</td> </tr> <tr> <td>Variable capacity unit</td> <td>51 to 100 <small>Note 1</small></td> <td>The smallest address of the indoor units + 50</td> </tr> <tr> <td>Constant capacity unit</td> <td>51 to 100 <small>Note 1</small></td> <td>Variable capacity unit address + 1</td> </tr> </tbody> </table> <p><small>Note 1.</small> If the address of the variable capacity unit or the constant capacity unit is set at 100, set one of the address switches at 01 ~ 50. <small>Note 2.</small> It is not necessary to set the 100's position in the remote control unit.</p>	Unit	Range	Setting method	Indoor unit	01 to 50	—	Remote control	101 to 150 <small>Note 2</small>	Indoor unit address + 100	Variable capacity unit	51 to 100 <small>Note 1</small>	The smallest address of the indoor units + 50	Constant capacity unit	51 to 100 <small>Note 1</small>	Variable capacity unit address + 1						
Unit	Range	Setting method																				
Indoor unit	01 to 50	—																				
Remote control	101 to 150 <small>Note 2</small>	Indoor unit address + 100																				
Variable capacity unit	51 to 100 <small>Note 1</small>	The smallest address of the indoor units + 50																				
Constant capacity unit	51 to 100 <small>Note 1</small>	Variable capacity unit address + 1																				
<p>2) 2 Remote control operation</p> <p>• 2 remote control units for 1 indoor unit.</p>	<p>a. Same as above b. Same as above c. Set the address setting switch as shown in the following table.</p> <table border="1" style="width:100%; border-collapse: collapse;"> <thead> <tr> <th>Unit</th> <th>Range</th> <th>Setting method</th> </tr> </thead> <tbody> <tr> <td>Indoor unit</td> <td>01 to 50</td> <td>—</td> </tr> <tr> <td>Main remote controller</td> <td>101 to 150 <small>Note 2</small></td> <td>Indoor unit address + 100</td> </tr> <tr> <td>Sub remote controller</td> <td>151 to 200 <small>Note 2</small></td> <td>Indoor unit address + 150</td> </tr> <tr> <td>Variable capacity unit</td> <td>51 to 100 <small>Note 1</small></td> <td>The smallest address of the indoor units + 50</td> </tr> <tr> <td>Constant capacity unit</td> <td>51 to 100 <small>Note 1</small></td> <td>Variable capacity unit address + 1</td> </tr> </tbody> </table> <p><small>Notes 1, 2.</small> Same as above</p>	Unit	Range	Setting method	Indoor unit	01 to 50	—	Main remote controller	101 to 150 <small>Note 2</small>	Indoor unit address + 100	Sub remote controller	151 to 200 <small>Note 2</small>	Indoor unit address + 150	Variable capacity unit	51 to 100 <small>Note 1</small>	The smallest address of the indoor units + 50	Constant capacity unit	51 to 100 <small>Note 1</small>	Variable capacity unit address + 1			
Unit	Range	Setting method																				
Indoor unit	01 to 50	—																				
Main remote controller	101 to 150 <small>Note 2</small>	Indoor unit address + 100																				
Sub remote controller	151 to 200 <small>Note 2</small>	Indoor unit address + 150																				
Variable capacity unit	51 to 100 <small>Note 1</small>	The smallest address of the indoor units + 50																				
Constant capacity unit	51 to 100 <small>Note 1</small>	Variable capacity unit address + 1																				
<p>3) Group operation</p> <p>• Operation of multiple indoor units with 1 remote controller.</p>	<p>a. Same as above b. Connect terminals A and B (M1 and M2) of the transmission line terminal block (TB5) of the indoor unit (IC Main) with the lowest address of all the indoor units (IC) in the same group and the terminals on the remote control (RC) terminal block (TB6).</p> <p>c. Set the address setting switch as shown in the following table.</p> <p>d. Within the same group, let the indoor unit (IC) which functions the most be the IC (Main) unit.</p> <table border="1" style="width:100%; border-collapse: collapse;"> <thead> <tr> <th>Unit</th> <th>Range</th> <th>Setting method</th> </tr> </thead> <tbody> <tr> <td>IC (Main)</td> <td>01 to 50</td> <td>Address of the indoor unit with the smallest address of all the indoor units in the same group</td> </tr> <tr> <td>IC (Sub)</td> <td>01 to 50</td> <td>Address of any of the indoor units except the address of the IC (Main) Let the number be in sequence with that of the IC (Main)</td> </tr> <tr> <td>Main remote controller</td> <td>101 to 150 <small>Note 2</small></td> <td>Address of the IC (Main) in the same group + 100</td> </tr> <tr> <td>Sub remote controller</td> <td>151 to 200 <small>Note 2</small></td> <td>Address of the IC (Main) in the same group + 150</td> </tr> <tr> <td>Variable capacity unit</td> <td>51 to 100 <small>Note 1</small></td> <td>The smallest address of the indoor units + 50</td> </tr> <tr> <td>Constant capacity unit</td> <td>51 to 100 <small>Note 1</small></td> <td>Variable capacity unit address + 1</td> </tr> </tbody> </table> <p><small>Notes 1, 2.</small> Same as above</p>	Unit	Range	Setting method	IC (Main)	01 to 50	Address of the indoor unit with the smallest address of all the indoor units in the same group	IC (Sub)	01 to 50	Address of any of the indoor units except the address of the IC (Main) Let the number be in sequence with that of the IC (Main)	Main remote controller	101 to 150 <small>Note 2</small>	Address of the IC (Main) in the same group + 100	Sub remote controller	151 to 200 <small>Note 2</small>	Address of the IC (Main) in the same group + 150	Variable capacity unit	51 to 100 <small>Note 1</small>	The smallest address of the indoor units + 50	Constant capacity unit	51 to 100 <small>Note 1</small>	Variable capacity unit address + 1
Unit	Range	Setting method																				
IC (Main)	01 to 50	Address of the indoor unit with the smallest address of all the indoor units in the same group																				
IC (Sub)	01 to 50	Address of any of the indoor units except the address of the IC (Main) Let the number be in sequence with that of the IC (Main)																				
Main remote controller	101 to 150 <small>Note 2</small>	Address of the IC (Main) in the same group + 100																				
Sub remote controller	151 to 200 <small>Note 2</small>	Address of the IC (Main) in the same group + 150																				
Variable capacity unit	51 to 100 <small>Note 1</small>	The smallest address of the indoor units + 50																				
Constant capacity unit	51 to 100 <small>Note 1</small>	Variable capacity unit address + 1																				
<p>1) ~ 3) above can be combined.</p>																						

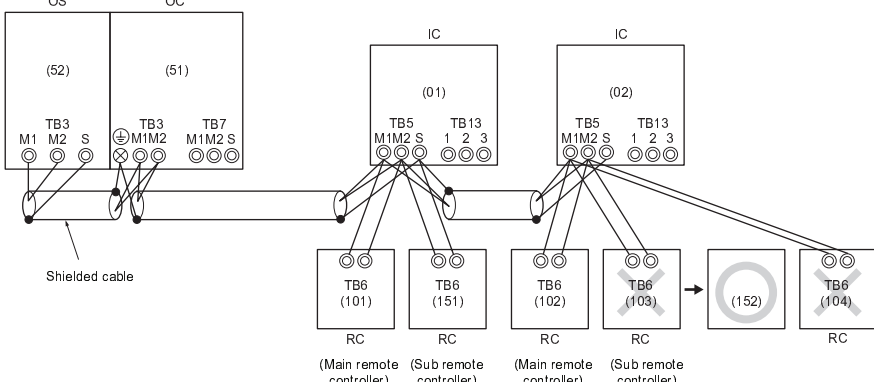
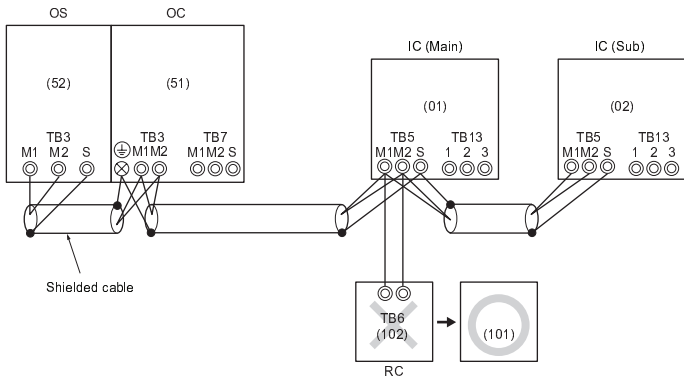
Permissible length	Prohibited items
<p>Length of the wire to the most remote indoor unit in the system (1.25 mm<sup>2</sup>)  <math>L_1 + L_2, L_2 + L_3, L_3 + L_1 \leq 200</math> m                      Remote control wire length</p> <ol style="list-style-type: none"> <li>In the case of 0.5 to 0.75 mm<sup>2</sup> wire,  <math>l_1, l_2 \leq 10</math> m</li> <li>If the length exceeds 10 m, use 1.25 mm<sup>2</sup> wire and let the length be within the length of the wire to the most remote indoor unit in the system (L<sub>3</sub>).</li> </ol>	<p style="text-align: center;">_____</p>
<p>Same as above</p>	 <ul style="list-style-type: none"> <li>Let the address of the sub remote controller be the indoor unit (IC) address + 150. In this case, the address would be 152.</li> <li>More than 3 remote control (RC) units cannot be connected to one indoor unit.</li> </ul>
<p>Same as above</p>	 <ul style="list-style-type: none"> <li>The remote controller address is the indoor unit main address + 100. In this case, it is 101.</li> </ul>

**Note:**

- If there is one or more 200 or higher indoor units within the same cooling system, and the number of indoor units exceeds 16 units, a transmission booster is necessary (when a "PAR-F25MA Ver. F" or subsequent version of remote control is used).
- If there is not even one 200 or higher indoor unit within the same cooling system, and the number of indoor units exceeds 20 units, a transmission booster is necessary (when a "PAR-F25MA Ver. F" or subsequent version of remote control is used).

\* For details, see wire connection example C.

B. Example of the use of the shielded cable in a system with group operation among multiple outdoor units (Setting of addresses is necessary)

Example of transmission line wiring

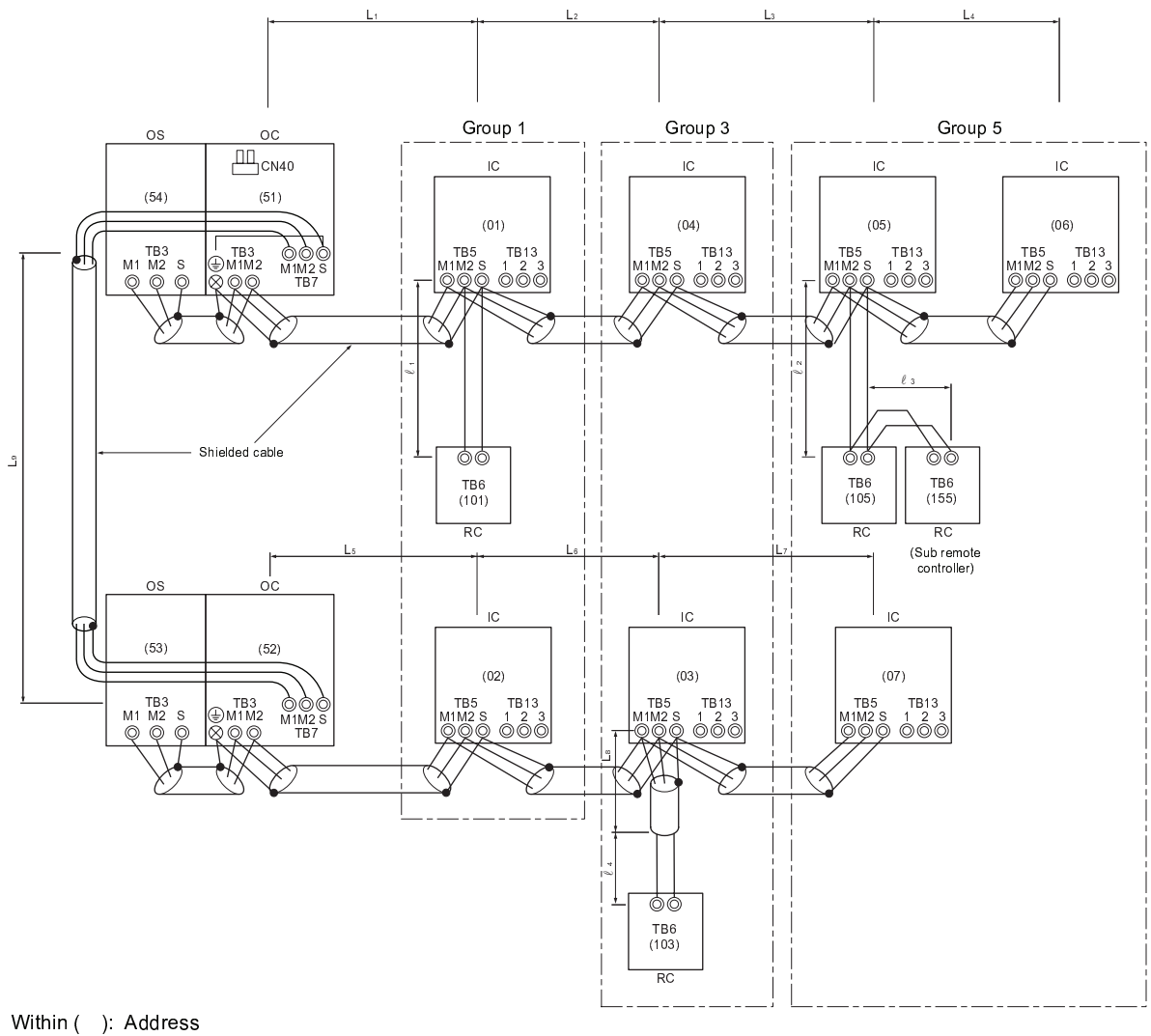

Wiring method, address setting method

- Be sure to use shielded cable for wiring between the outdoor units (OC and OS) and indoor units (IC), between OC and OC and between IC and IC.
- Terminals M1 and M2 and the ground terminal ⊕ of the transmission line terminal block (TB3) of each variable capacity unit (OC), terminals M1, M2 and S of the transmission line terminal block (TB3) ⊕ of the constant capacity unit (OS) and terminals M1, M2 and S of the transmission line terminal block (TB5) of each indoor unit (IC) should be cross wired.
- Connect the M1 and M2 terminals of the transmission line terminal block (TB5) of the indoor unit IC (Main) with the smallest address within the same group to the remote control (RC) terminal block (TB6).
- Connect terminals M1, M2 and S of the centralized control terminal block (TB7) of the variable capacity unit (OC) and the terminals M1, M2 and S of the centralized control terminal block (TB7) of the variable capacity unit (OC) of the other cooling systems.
- The power supply connector on the main board can be changed from CN41 to CN40 for only one variable capacity unit (OC).
- Connect the S terminal of the centralized control terminal block (TB7) of the variable capacity unit (OC) which had its power supply connector connected to CN40 in e to the ground terminal ⊕ in the electrical equipment panel.
- Group settings between multiple cooling systems should be performed after the power is turned on using the remote control (RC) units. For the setting method, refer to the installation manual for the remote control unit.

Unit	Range	Setting method
IC (Main)	01 to 50	Smallest address of all the indoor units (IC) in the same group
IC (Sub)	01 to 50	Address other than the IC (Main) of the indoor units in the same group Use a number which is in sequence with that of the IC (Main)
Main remote controller	101 to 150 Note 2	IC (Main) + 100
Sub remote controller	151 to 200 Note 2	IC (Main) + 150
Variable capacity unit	51 to 100 Note 1	The smallest address of the indoor units in the same cooling system + 50
Constant capacity unit	51 to 100 Notes 1, 3	Variable capacity unit address + 1

- Note:**
- If the address of the variable capacity unit or the constant capacity unit is set at 100, set the address setting switch at either 01 or 50.
  - It is not necessary to set the 100's position on the remote control unit.
  - If the addresses overlap with the variable capacity unit of other cooling systems, select a different unused address.

Permissible length

- Length of wire to the most remote unit via the outdoor unit:  $L_1+L_2+L_3+L_4+L_5+L_6+L_7+L_9$ ,  
 $L_1+L_2+L_3+L_4+L_5+L_6+L_8+L_9 \leq 500 \text{ m (1.25 mm}^2\text{)}$
- Length of wire to the most remote unit via the indoor system:  $L_1+L_2+L_3+L_4$ ,  $L_5+L_6+L_7$ ,  $L_5+L_6+L_8$ ,  $L_7+L_8 \leq 200 \text{ m (1.25 mm}^2\text{)}$
- Remote control wire length:  $l_1, l_2, l_3, l_4 \leq 10 \text{ m (0.5 to 0.75 mm}^2\text{)}$   
 If the length exceeds 10 m, use 1.25 mm<sup>2</sup> wire and calculate the length of that portion (L<sub>8</sub>) as within the total extended length and the length to the most remote unit.

Prohibited items

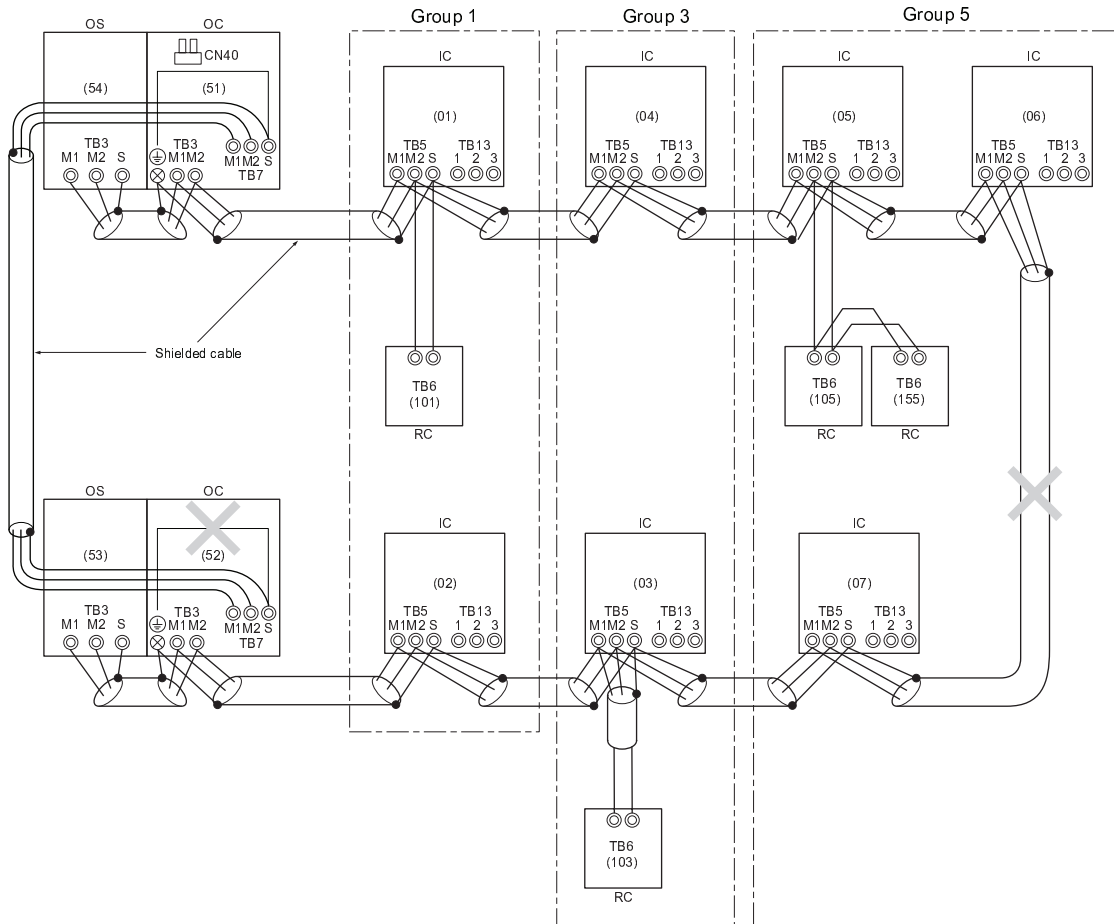

- Connect the S terminal of the centralized control terminal block (TB7) of one variable capacity unit only to the ground (⊕) of the electrical equipment panel.
- The transmission line terminal blocks (TB5) of indoor units (IC) connected to different cooling systems should not be connected together.

**Note:**

- If there is one or more 200 or higher indoor units within the same cooling system, and the number of indoor units exceeds 16 units, a transmission booster is necessary (when a "PAR-F25MA Ver. F" or subsequent version of remote control is used).
- If there is not even one 200 or higher indoor unit within the same cooling system, and the number of indoor units exceeds 20 units, a transmission booster is necessary (when a "PAR-F25MA Ver. F" or subsequent version of remote control is used).

\* For details, see wire connection example C.

C. Example of a system using the transmission booster (Combination of systems A to C)

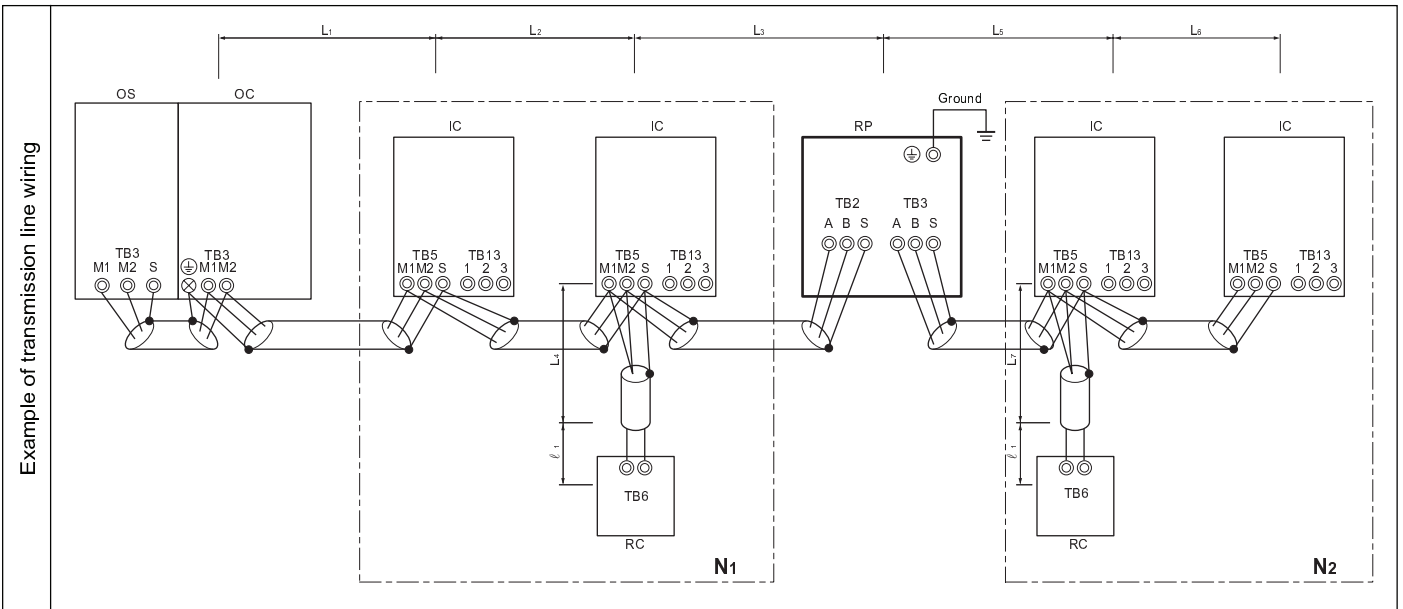

- Example of transmission line wiring
- Address settings are the same as for wiring connection examples A and B.
  - Let the number of indoor units and remote control units connected be within the limit for the number of units shown in the following table for the total of the number of units connected between the variable capacity unit (OC) and the transmission booster (RP) N1 and the number of units connected after the transmission booster (RP) N2.
  - Connect the power supply ground to the transmission booster (RP) securely.  
Connect the transmission lines of the outdoor unit side to terminals A and B of transmission line terminal block 1 (TB2) of the transmission booster (RP).  
Connect the transmission lines of the expansion indoor unit side to terminals A and B of the of transmission line terminal block 2 (TB3) of the transmission booster (RP).

Wiring method, address setting method

(*1) Capability of the connected indoor units	Remote controller type	Remote controller PAR-F 25MA	
	Number of connected indoor units that can be connected without a RP	Prior to Ver. E	After Ver. F
200 or lower		16 (32)	20 (40)
200 or higher		16 (32)	16 (32)

The number of indoor units and the total number of remote controllers is displayed within the parenthesis ( ).

\*1 If even one unit that is higher than 200 exists in the cooling system, the maximum capacity will be "200 or higher".

- Permissible length
- Indoor system maximum remote wiring length:
    - $L_1+L_2+L_3+L_5+L_6 \leq 200$  m (1.25 mm<sup>2</sup>)
    - $L_1+L_2+L_3+L_5+L_7 \leq 200$  m (1.25 mm<sup>2</sup>)
    - $L_1+L_2+L_4 \leq 200$  m (1.25 mm<sup>2</sup>)
    - $L_6+L_5+L_3+L_4, L_4+L_3+L_5+L_7 \leq 200$  m (1.25 mm<sup>2</sup>)
  - Remote control wiring length:  $l_1, l_2 \leq 10$  m (0.5 to 0.75 mm<sup>2</sup>)  
If the length exceeds 10 m, use 1.25 mm<sup>2</sup> shielded cable and calculate the length of that portion (L4 and L7) as within the total extended length and the longest remote length.

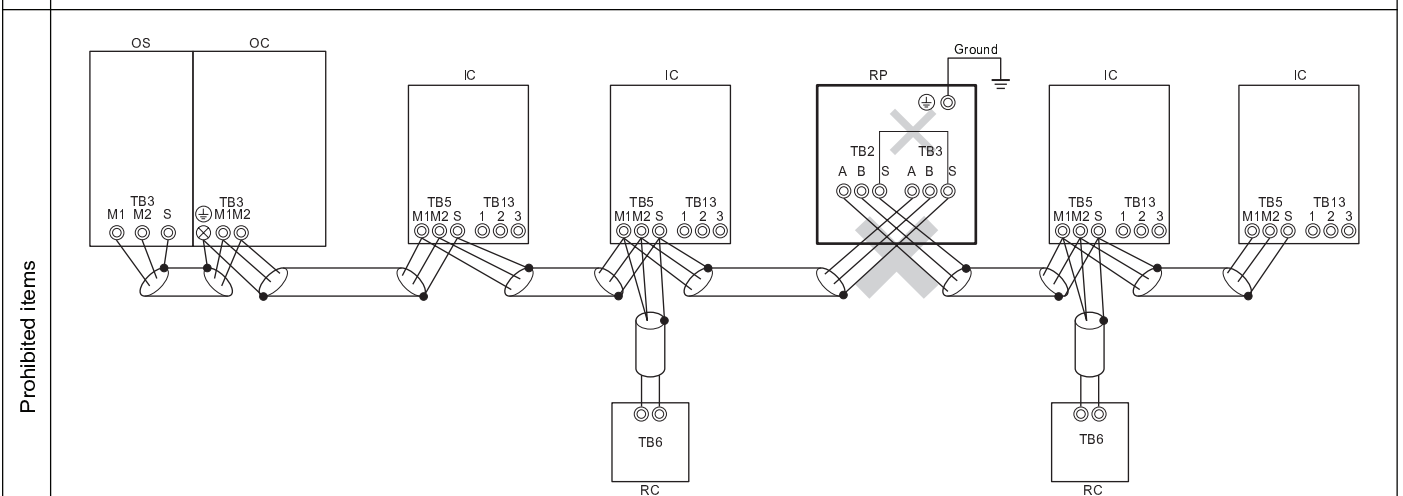

- Do not mistake the connection locations of transmission booster (RP) transmission line terminal block 1 (TB2) and transmission line terminal block 2 (TB3). (Operation will not be normal in such a case.)
- Do not connect the S terminals of transmission line terminal block 1 (TB2) and transmission line terminal block 2 (TB3) of the transmission booster (RP) together.



## 11.4. Wiring of main power supply and equipment capacity

### ⚠ Warning:

- Be sure to use specified wires to connect so that no external force is imparted to terminal connections. If connections are not fixed firmly, it may cause heating or fire.
- Be sure to use the appropriate type of overcurrent protection switch. Note that generated overcurrent may include some amount of direct current.

### ⚠ Caution:

- The reverse phase of L lines (L1, L2, L3) can be detected (Error cord: 4103), but the reverse phase of L lines and N line can not be detected.
  - The some electric parts should be damaged when power is supplied under the miss wiring.
- Some installation site may require attachment of an earth leakage breaker. If no earth leakage breaker is installed, it may cause an electric shock.
- Do not use anything other than breaker and fuse with correct capacity. Using fuse and wire or copper wire with too large capacity may cause a malfunction of unit or fire.

### Schematic drawing of wiring (example)

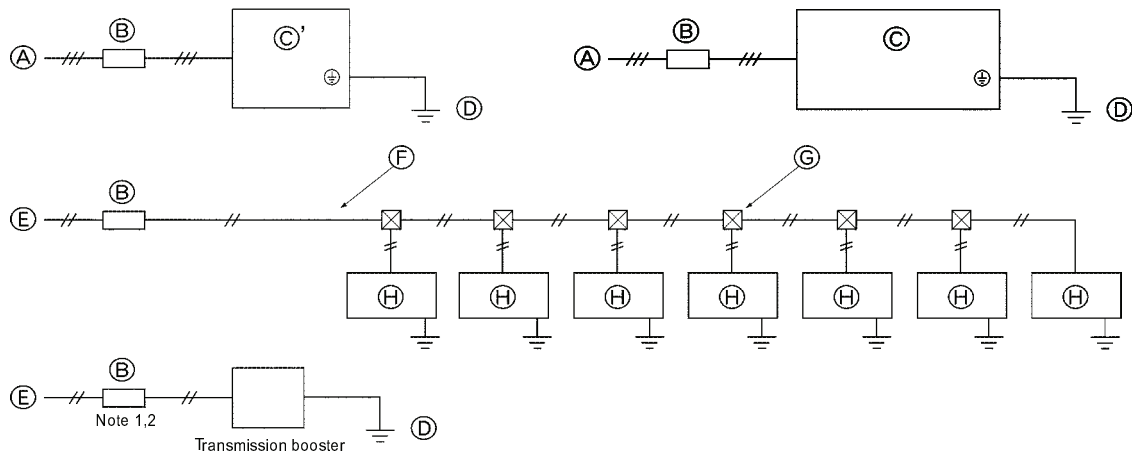

### Note:

1. The transmission booster may be required according to the number of indoor units connected. (For details, see item 11.3. "Wiring transmission cables")
2. For switch capacity, see the installation manual for transmission booster.

- |                                                   |                                                |
|---------------------------------------------------|------------------------------------------------|
| Ⓐ Power supply (3-phase, 4-wire) 380/400/415 volt | Ⓔ Power supply (single-phase) 220/230/240 volt |
| Ⓑ Switch                                          | Ⓕ 1.5 mm <sup>2</sup> or more                  |
| Ⓒ Variable capacity unit                          | Ⓖ Pull box                                     |
| Ⓒ' Constant capacity unit                         | Ⓗ Indoor unit                                  |
| Ⓓ Ground                                          |                                                |

### Thickness of wire for main power supply and on/off capacities (example)

Model	Minimum wire thickness (mm <sup>2</sup> )			Switch (A)		Breaker for wiring (NFB)	Breaker for current leakage	
	Main cable	Branch	Ground	Capacity	Fuse			
Outdoor unit	PUHY-400	10.0	-	10.0	63	63	20 A	75 A 100 mA 0.1 sec. or less
	PUHY-500	16.0	-	16.0	63	63		
	PUHN-200	4.0	-	4.0	32	32	40 A	30 A 100 mA 0.1 sec. or less 40 A 100 mA 0.1 sec. or less
	PUHN-250	6.0	-	6.0	40	40		

Model		Wire thickness (mm <sup>2</sup> )			Switch (A)		Breaker for wiring (NFB)	Breaker for current leakage
		Main cable	Branch	Ground	Capacity	Fuse		
Total operating current of the indoor units	16 A or less	1.5	1.5	1.5	16	16	20 A	20 A 30 mA 0.1 sec. or less
	25 A or less	2.5	1.5	1.5	25	25	30 A	30 A 30 mA 0.1 sec. or less
	32 A or less	4.0	4.0	4.0	32	32	40 A	40 A 30 mA 0.1 sec. or less

1. Use a separate power supply for the outdoor unit and indoor unit.
2. Bear in mind ambient conditions (ambient temperature, direct sunlight, rain water, etc.) when proceeding with the wiring and connections.
3. The wire size is the minimum value for metal conduit wiring. The power cord size should be 1 rank thicker consideration of voltage drops. Make sure the power-supply voltage does not drop more than 10%.
4. Specific wiring requirements should adhere to the wiring regulations of the region.
5. Power supply cords of parts of appliances for outdoor use shall not be lighter than polychloroprene sheathed flexible cord (design 245 IEC57). For example, use wiring such as YZW.
6. The total operating current of the indoor units may fluctuate depending on the operating status of the indoor units. In order to prevent malfunctions, use a circuit breaker with a current of about 20% more than that listed in the specifications.

## 12. Test run

### 12.1. Checking before getting test run

1	Check to see whether there are refrigerant leakage, and slack of power or transmission cable.
2	Confirm that 500 V megger shows 1.0 MΩ or more between power supply terminal block and ground. Do not operate in the case of 1.0 MΩ or less. NOTE: Never carry out megohm check over terminal control board. Otherwise the control board would be broken. Immediately after mounting the unit or after leaving it turned off for an extended length of time, the resistance of the insulation between the power supply terminal board and the ground may decrease to approx. 1.0 MΩ as a result of refrigerant accumulating in the internal compressor. If the insulation resistance is more than 1.0 MΩ, turning on the main power supply and energizing the crankcase heater for more than 12 hours will cause the refrigerant to evaporate, increasing the insulation resistance.
3	Check to see whether both gas and liquid valves are fully open. NOTE: Be sure to tighten caps.
4	Check the phase sequence and the voltage between phases. NOTE: If the phase sequence is reversed, an error (4103) may occur when a test run is made, causing the unit to stop.
5	If a transmission booster is connected: Turn transmission booster power on the before turning the outdoor unit's power on. NOTE 1: If the outdoor unit's power is turned on first, refrigerant system connection data may not be recognized normally. NOTE 2: If the outdoor unit's power is turned on first, reset the outdoor unit's power after turning the transmission booster power on.
6	Turn on universal power supply at least 12 hours before getting test run in order to carry current to crank case heater. If current-carrying hours are too short, it may result in a malfunction of compressor.

### 12.2. Test run method

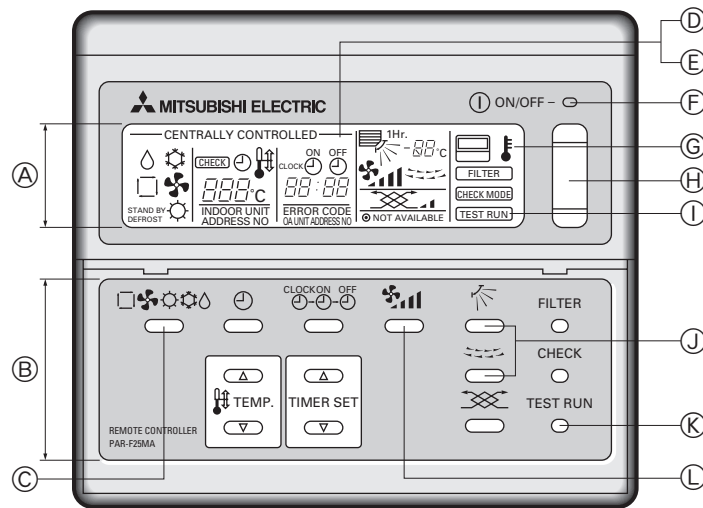

- Ⓐ Display panel
- Ⓑ Control panel
- Ⓒ Cooling/Heating select button ③, ④
- Ⓓ Check code indicator (see note 1)
- Ⓔ Test run remaining time indicator (see note 3)
- Ⓕ ON/OFF LED (lights up in operation)
- Ⓖ Indoor unit liquid pipe temperature indicator (see note 4)
- Ⓗ ON/OFF button ⑨
- Ⓘ Test run indicator
- Ⓙ Wind adjust button ⑥
- Ⓚ Test run button ②
- Ⓛ Air blow adjust button ⑤

Operation procedure	
①	Turn on universal power supply at least 12 hours before getting started → displaying "HO" on display panel for about two minutes. The universal power supply must be left on for at least 12 hours (with the crank case heater turned on). If a transmission booster is connected, turn transmission booster power on the before turning the outdoor unit's power on.
②	Press [TEST RUN] button twice → displaying "TEST RUN" on display panel.
③	Press [Cooling/Heating] select button → make sure that air is blowing out.
④	Press [Cooling/Heating] select button to change from cooling to heating operation, and vice versa → make sure that warm or cold air is blowing out.
⑤	Press [Wind] adjust button → make sure that air blow is changed.
⑥	Press [Up/Down Wind] or [Louver] button to change wind → Make sure that horizontal or downward blow is adjustable.
⑦	→ Make sure that indoor unit fans operate normally.
⑧	Make sure that interlocking devices such as ventilator operate normally if any.
⑨	Press [ON/OFF] button to cancel test run → Stop operation.
NOTE 1: If check code is displayed on remote controller or remote controller does not operate normally, see page 35 or further.	
NOTE 2: Test run automatically stops operating after two hours by activation of timer set to two hours.	
NOTE 3: During test run, test run remaining time is displayed on time display section.	
NOTE 4: During test run, temperature of liquid pipe in indoor unit is displayed on remote controller room temp. display section.	
NOTE 5: When pressing [Wind] adjust button, depending on the model, "This function is not available" may be displayed on remote controller. However, it is not a malfunction.	
NOTE 6: If the outdoor temperature is low, the unit may not operate for up to 4 hours.	

## 12.3. How to cope with test run abnormality

① A 4-digit check code is displayed on remote controller display panel if unit is stopped due to an abnormality. Check to see causes of that abnormality.

### 1. Indoor unit

Check code	Abnormality	Check code	Abnormality
2500	Water leakage abnormality	6603	Transmission error (Transmission route BUSY)
2502	Drain pump error	6606	Transmission and reception error (Communication trouble with transmission processor)
2503	Drain sensor error, Float switch on		
5101	Air inlet sensor error	6607	Transmission and reception error (No ACK error)
5102	Piping sensor error	6608	Transmission and reception error (No responsive frame error)
5103	Piping sensor error in the gas side		
6600	Duplicated unit address setting	7101	Capacity code error
6602	Transmission error	7111	Remote controller sensor error
	(Transmission processor hardware error)		

### 2. Outdoor unit

#### a. Variable capacity unit

Check code	Abnormality	Check code	Abnormality
0403	Serial transmission malfunction	5105	Piping temperature sensor error (TH5)
1102	Discharge temperature abnormality	5106	Outdoor temperature sensor error (TH6)
1111	Low pressure saturated temperature abnormality (Detected by saturated temperature sensor)	5107	Subcool coil liquid outlet temperature sensor error (TH7)
1112	Low pressure saturated temperature abnormality (Detected by liquid level detecting temperature sensor)	5108	Subcool coil bypass outlet temperature sensor error (TH8)
1113	Low pressure saturated temperature abnormality (Detected by liquid level detecting temperature sensor)	5109	Sub cool coil bypass inlet temperature sensor error (TH9)
		5110	Inverter cooling plate temperature sensor error (THHS)
1301	Low pressure abnormality	5112	Gas pipe sensor error (TH10a)
1302	High pressure abnormality	5113	Gas pipe sensor error (TH10b)
1500	Excessive refrigerant replenishment	5201	High-pressure sensor (HPS) error
1501	Lacked refrigerant abnormality	5301	IDC sensor circuit error
1505	Low pressure abnormality	6600	Duplicated unit address setting
4103	Reverse phase	6602	Transmission error (Transmission processor hardware error)
4108	Overload protection (Comp overcurrent)		
4115	Power supply simultaneous signal abnormality	6603	Transmission error (Transmission route BUSY)
4116	Fan speed abnormality (Motor abnormality)	6606	Transmission and reception error (Communication trouble with transmission processor)
4200	VDC detection circuit error		
4210	Overcurrent interruption	6607	Transmission and reception error (No ACK error)
4220	Inverter bus line voltage low	6608	Transmission and reception error (No responsive frame error)
4230	Overheat protection of radiator panel		
4240	Overcurrent protection	7100	Total capacity error
4260	Cooling fan abnormality	7101	Capacity code error
5101	Discharge temperature sensor error (TH1)	7102	Connecting unit number error
5102	Low pressure saturated temperature error (TH2)	7105	Address set error
5103	Liquid surface detecting temperature sensor error (TH3)	7109	Incorrect connection
5104	Liquid surface detecting temperature sensor error (TH4)	7130	Incorrect setup

#### b. Constand capacity unit

Check code	Abnormality	Check code	Abnormality
1102	Discharge temperature abnormality	5106	Outdoor temperature sensor error (TH6)
1112	Low pressure saturated temperature abnormality (Detected by liquid level detecting temperature sensor)	5107	Subcool coil liquid outlet temperature sensor error (TH7)
		5108	Subcool coil bypass outlet temperature sensor error (TH8)
1113	Low pressure saturated temperature abnormality (Detected by liquid level detecting temperature sensor)	5109	Sub cool coil bypass inlet temperature sensor error (TH9)
		5112	Gas pipe sensor error (TH10a)
1302	High pressure abnormality	5113	Gas pipe sensor error (TH10b)
1500	Excessive refrigerant replenishment	6600	Duplicated unit address setting
1505	Low pressure abnormality	6602	Transmission error (Transmission processor hardware error)
1559	Faulty oil balance circuit		
4103	Reverse phase error	6603	Transmission error (Transmission route BUSY)
4106	Power failure error		
4108	Overload protection (Comp overcurrent)	6606	Transmission and reception error (Communication trouble with transmission processor)
4115	Power supply simultaneous signal abnormality		
5101	Discharge temperature sensor error (TH1)	6607	Transmission and reception error (No ACK error)
5103	Liquid surface detecting temperature sensor error (TH3)	6608	Transmission and reception error (No responsive frame error)
5104	Liquid surface detecting temperature sensor error (TH4)		
5105	Piping temperature sensor error (TH5)		

3. Remote controller

Check code	Abnormality	Check code	Abnormality
6101	Unreadable response receiving error	6606	Transmission and reception error (Communication trouble with transmission processor)
6600	Duplicated unit address setting		
6602	Transmission error (Transmission processor hardware error)	6607	Transmission and reception error (No ACK error)
6603	Transmission error (Transmission route BUSY)	6608	Transmission and reception error (No responsive frame error)

② Diagnostic switch (SW1) and the service LED on multi-controller board of the variable capacity unit can be used to judge a malfunction of outdoor unit.

<Operation of self-diagnosis switch (SW1) and the service LED display>

Self-diagnosing item	SW1 setting	Display at LED lighting (blinking)								Remarks
		Flag 1	Flag 2	Flag 3	Flag 4	Flag 5	Flag 6	Flag 7	Flag 8	
① Relay output display 1 (Lighting) Check display 1 (Blinking)		During compressor run	Compressor 1 operations	Compressor 2 operations	21S4	SV1		SV22/32	Always lighting	Flag 8 always lights at microcomputer power ON
		0000 to 9999 (Alternate display of address and error code)								
	Relay output display 2		SV4	21S4b	SV5b	SV6	CH2, 3	52F		
② Check indoor unit		No.1 unit	No.2 unit	No.3 unit	No.4 unit	No.5 unit	No.6 unit	No.7 unit	No.8 unit	Lights at emergency stop in IC Turns off by resetting
		No.9 unit	No.10 unit	No.11 unit	No.12 unit	No.13 unit	No.14 unit	No.15 unit	No.16 unit	
		No.17 unit	No.18 unit	No.19 unit	No.20 unit	No.21 unit	No.22 unit	No.23 unit	No.24 unit	
		No.25 unit	No.26 unit	No.27 unit	No.28 unit	No.29 unit	No.30 unit	No.31 unit	No.32 unit	
③ Indoor unit mode		No.1 unit	No.2 unit	No.3 unit	No.4 unit	No.5 unit	No.6 unit	No.7 unit	No.8 unit	Lights at cooling Blinks at heating Turns off at stop/fan
		No.9 unit	No.10 unit	No.11 unit	No.12 unit	No.13 unit	No.14 unit	No.15 unit	No.16 unit	
		No.17 unit	No.18 unit	No.19 unit	No.20 unit	No.21 unit	No.22 unit	No.23 unit	No.24 unit	
		No.25 unit	No.26 unit	No.27 unit	No.28 unit	No.29 unit	No.30 unit	No.31 unit	No.32 unit	
Indoor unit thermostat		No.1 unit	No.2 unit	No.3 unit	No.4 unit	No.5 unit	No.6 unit	No.7 unit	No.8 unit	Lights at thermostat on Turns off at thermostat off
		No.9 unit	No.10 unit	No.11 unit	No.12 unit	No.13 unit	No.14 unit	No.15 unit	No.16 unit	
		No.17 unit	No.18 unit	No.19 unit	No.20 unit	No.21 unit	No.22 unit	No.23 unit	No.24 unit	
		No.25 unit	No.26 unit	No.27 unit	No.28 unit	No.29 unit	No.30 unit	No.31 unit	No.32 unit	
Indoor unit address		Displays in order the addresses (1 through 50) of all indoor units connected to the outdoor unit.								

① Outdoor unit  
A ON

② Indoor unit  
B OFF

③ At factory shipment

\* Turn SW4-2 of variable capacity unit off. If SW4-2 is on, constant capacity unit data will be displayed.

## Displaying the service LED

Service LED (LD1) 

- Error code display  
Alternate display of error generating address and error code  
Example At outdoor unit address 51, abnormal discharge temperature (Code 1102)
- Flag display  
Example SV1 ON under only compressor 1 operated

 → 

  
A B C D E F G H

- Ⓐ Flag 1
- Ⓑ Flag 2
- Ⓒ Flag 3
- Ⓓ Flag 4
- Ⓔ Flag 5
- Ⓕ Flag 6
- Ⓖ Flag 7
- Ⓗ Flag 8

## 12.4. Coping with remote controller abnormality

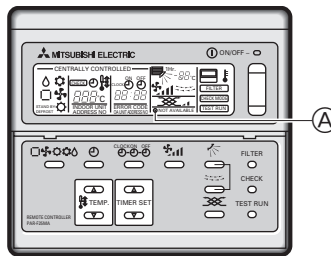

Ⓐ Display: Appears when current is carried

	Phenomenon	Cause	How to cope with abnormality
1	Unit does not operate and display stays off even after pressing remote controller ON switch. (Current-carrying indicator does not light up)	(1) Outdoor unit power was not turned on. (2) Transmission or remote controller cable was shorted or connection failure. (3) Power cable contact failure. (4) Remote controller was erroneously connected to unit remote controller terminal block. (5) Too many remote controllers or indoor units were connected.	(a) Check voltage between remote controller terminals. (i) Remote controller fails when voltage is 17 to 30 V. (ii) If there is no voltage <ul style="list-style-type: none"> <li>• Check the number of remote controllers and indoor units connected.</li> <li>• Remove wire from transmission cable terminal block (TB3) on outdoor unit, and check voltage between terminals. <ul style="list-style-type: none"> <li>• If voltage is 17 to 30 V, check (2) and (4) at left.</li> <li>• If there is no voltage, check (1) and (3) at left.</li> </ul> </li> </ul>
2	"HO" indicator does not disappear. Unit does not operate even if the switch is pressed.	(1) No transmission cable was connected to transmission cable terminal block on the indoor unit. (2) Outdoor unit address was erroneously set. (3) Indoor unit address was erroneously set.	<ul style="list-style-type: none"> <li>• Check all items at left.</li> </ul>
3	Display comes on once but disappears immediately after a press of the switch.	(1) Indoor unit power was not turned on.	<ul style="list-style-type: none"> <li>• Check item at left.</li> </ul>

## 12.5. The following phenomena do not represent abnormality (emergency)

Phenomenon	Display of remote controller	Cause
Indoor unit does not perform cooling (heating) operation.	"Cooling (heating)" flashes	When another indoor unit is performing the heating (cooling) operation, the cooling (heating) operation is not performed.
The auto vane runs freely.	Normal display	Because of the control operation of auto vane, it may change over to horizontal blow automatically from the downward blow in cooling in case the downward blow operation has been continued for 1 hour. At defrosting in heating, hot adjusting and thermostat OFF, it automatically changes over to horizontal blow.
Fan setting changes during heating.	Normal display	Ultra-low speed operation is commenced at thermostat OFF. Light air automatically changes over to set value by time or piping temperature at thermostat ON.
Fan stops during heating operation.	Defrost display	The fan is to stop during defrosting.
Fan does not stop while operation has been stopped.	No lighting	Fan is to run for 1 minute after stopping to exhaust residual heat (only in heating).
No setting of fan while start SW has been turned on.	Heat ready	Ultra low-speed operation for 5 minutes after SW ON or until piping temperature becomes 35°C, low speed operation for 2 minutes thereafter, and then set notch is commenced. (Hot adjust control)
Outdoor unit does not operate by turning switch on.	Normal display	When the outdoor unit is being cooled and the refrigerant is resting, warming up operation is performed for at least 35 minutes to warm the compressor. During this time, only the fan operates.
Indoor unit remote controller shows "HO" indicator for about two minutes when turning ON universal power supply.	"HO" flashes	System is being driven. Operate remote controller again after "HO" disappear.
Drain pump does not stop while unit has been stopped.	Light out	After a stop of cooling operation, unit continues to operate drain pump for three minutes and then stops it.
Drain pump continues to operate while unit has been stopped.		Unit continues to operate drain pump if drainage is generated, even during a stop.
When the variable capacity unit is running, the fan of the constant capacity unit runs even though the constant capacity unit isn't running.	Normal display	The fan of constant capacity unit is run automatically in order not to accumulate the refrigerant.



---

This product is designed and intended for use in the residential,  
commercial and light-industrial environment.

The product at hand is  
based on the following  
EU regulations:

- The equipment Safety Law (GSG) accepted  
by RW-TUV.
- Low Voltage Directive 73/23/EEC
- Electromagnetic Compatibility Directive 89/  
336/EEC
- Machinery Directive 89/392/EEC

Please be sure to put the contact address/telephone number on  
this manual before handing it to the customer.

 **MITSUBISHI ELECTRIC CORPORATION**