

MITSUBISHI ELECTRIC CITY MULTI

Air-Conditioners OUTDOOR UNIT



PUHY-P-YMF-B

**FOR INSTALLER
FÜR INSTALLATEUR
POUR L'INSTALLATEUR
VOOR DE INSTALLATEUR
PER L'INSTALLATORE**

ENGLISH

DEUTSCH

FRANÇAIS

NEDERLANDS

ITALIANO

INSTALLATION MANUAL

For safe and correct use, please read this installation manual thoroughly before installing the air-conditioner unit.

* Remote controller (PAR-F25MA) is available as an optional remote controller.

INSTALLATIONSHANDBUCH

Zum sicheren und ordnungsgemäßen Gebrauch der Klimageräte das Installationshandbuch gründlich durchlesen.

* Fernbedienung (PAR-F25MA) ist als Zubehör wahlweise erhältlich.

MANUEL D'INSTALLATION

Veillez lire le manuel d'installation en entier avant d'installer ce climatiseur pour éviter tout accident et vous assurer d'une utilisation correcte.

* La télécommande (PAR-F25MA) est disponible en option.

INSTALLATIEHANDLEIDING

Voor een veilig en juist gebruik moet u deze installatiehandleiding grondig doorlezen voordat u de airconditioner installeert.

* De afstandsbedieningseenheid (PAR-F25MA) is verkrijgbaar als een optioneel toe te voegen afstandsbediening.

MANUALE DI INSTALLAZIONE

Per un uso sicuro e corretto, leggere attentamente questo manuale di installazione prima di installare il condizionatore d'aria.

* Il comando a distanza (modello PAR-F25MA) disponibile in opzione.

Contents

1. Safety precautions	3
1.1. Before installation and electric work	3
1.2. Precautions for devices that use R407C refrigerant	3
1.3. Before getting installed	4
1.4. Before getting installed (moved) - electrical work	4
1.5. Before starting the test run	4
2. Combination with indoor units	5
3. Confirmation of parts attached	5
4. Combination with outdoor units	6
5. Selection of installation site	6
6. Space required around unit	6
6.1. Individual installation	6
6.2. Collective installation and continuous installation	7
7. Lifting method and weight of product	8
8. Installation of unit	8
8.1. Location of anchor bolt	8
8.2. Installation	9
8.3. Connecting direction for refrigerant piping	10
8.4. Noise level	10
9. Caution for snow and seasonal wind	11
9.1. Snow and seasonal wind	11
9.2. Countermeasure to seasonal wind	11
10. Refrigerant piping installation	11
10.1. Areas of caution	12
10.2. Refrigerant piping system	13
10.3. Caution for piping connection/valve operation	15
10.4. How to install branch pipe	16
10.5. Airtight test and evacuation, refrigerant charging	18
10.6. Thermal insulation of refrigerant piping	21
11. Electrical work	23
11.1. Caution	23
11.2. Control box and connecting position of wiring	24
11.3. Wiring transmission cables	25
11.4. Wiring of main power supply and equipment capacity	31
12. Test run	32
12.1. Checking before getting test run	32
12.2. Test run method	32
12.3. How to cope with test run abnormality	33
12.4. Coping with remote controller abnormality	35
12.5. The following phenomena do not represent abnormality (emergency)	36

1. Safety precautions

1.1. Before installation and electric work

- ▶ **Before installing the unit, make sure you read all the “Safety precautions”.**
- ▶ **The “Safety precautions” provide very important points regarding safety. Make sure you follow them.**
- ▶ **This equipment may not be applicable to EN61000-3-2: 1995 and EN61000-3-3: 1995.**
- ▶ **This equipment may cause the adverse effect on the same supply system.**
- ▶ **Please report to or take consent by the supply authority before connection to the system.**

Symbols used in the text









Warning:

Describes precautions that should be observed to prevent danger of injury or death to the user.

Caution:

Describes precautions that should be observed to prevent damage to the unit.

Symbols used in the illustrations

-  : Indicates an action that must be avoided.
-  : Indicates that important instructions must be followed.
-  : Indicates a part which must be grounded.
-  : Indicates that caution should be taken with rotating parts. (This symbol is displayed on the main unit label.) <Color: Yellow>
-  : Indicates that the main switch must be turned off before servicing. (This symbol is displayed on the main unit label.) <Color: Blue>
-  : Beware of electric shock. (This symbol is displayed on the main unit label.) <Color: Yellow>
-  : Beware of hot surface. (This symbol is displayed on the main unit label.) <Color: Yellow>
-  **ELV** : Please pay attention to electric shock fully because this is not Safety Extra Low-Voltage (SELV) circuit. And at servicing, please shut down the power supply for both of Indoor Unit and Outdoor Unit.

Warning:

Carefully read the labels affixed to the main unit.

Warning:

- **Ask the dealer or an authorized technician to install the air conditioner.**
 - Improper installation by the user may result in water leakage, electric shock, or fire.
- **Install the air unit at a place that can withstand its weight.**
 - Inadequate strength may cause the unit to fall down, resulting in injuries.
- **Use the specified cables for wiring. Make the connections securely so that the outside force of the cable is not applied to the terminals.**
 - Inadequate connection and fastening may generate heat and cause a fire.
- **Prepare for typhoons and other strong winds and earthquakes and install the unit at the specified place.**
 - Improper installation may cause the unit to topple and result in injury.
- **Always use an air cleaner, humidifier, electric heater, and other accessories specified by Mitsubishi Electric.**

- Ask an authorized technician to install the accessories. Improper installation by the user may result in water leakage, electric shock, or fire.
- **Never repair the unit. If the air conditioner must be repaired, consult the dealer.**
 - If the unit is repaired improperly, water leakage, electric shock, or fire may result.
- **Do not touch the heat exchanger fins.**
 - Improper handling may result in injury.
- **If refrigerant gas leaks during installation work, ventilate the room.**
 - If the refrigerant gas comes into contact with a flame, poisonous gases will be released.
- **Install the air conditioner according to this Installation Manual.**
 - If the unit is installed improperly, water leakage, electric shock, or fire may result.
- **Have all electric work done by a licensed electrician according to “Electric Facility Engineering Standard” and “Interior Wire Regulations” and the instructions given in this manual and always use a special circuit.**
 - If the power source capacity is inadequate or electric work is performed improperly, electric shock and fire may result.
- **Securely install the outdoor unit terminal cover (panel).**
 - If the terminal cover (panel) is not installed properly, dust or water may enter the outdoor unit and fire or electric shock may result.
- **When installing and moving the air conditioner to another site, do not charge the it with a refrigerant different from the refrigerant (R407C) specified on the unit.**
 - If a different refrigerant or air is mixed with the original refrigerant, the refrigerant cycle may malfunction and the unit may be damaged.
- **If the air conditioner is installed in a small room, measures must be taken to prevent the refrigerant concentration from exceeding the safety limit even if the refrigerant should leak.**
 - Consult the dealer regarding the appropriate measures to prevent the safety limit from being exceeded. Should the refrigerant leak and cause the safety limit to be exceeded, hazards due to lack of oxygen in the room could result.
- **When moving and reinstalling the air conditioner, consult the dealer or an authorized technician.**
 - If the air conditioner is installed improperly, water leakage, electric shock, or fire may result.
- **After completing installation work, make sure that refrigerant gas is not leaking.**
 - If the refrigerant gas leaks and is exposed to a fan heater, stove, oven, or other heat source, it may generate noxious gases.
- **Do not reconstruct or change the settings of the protection devices.**
 - If the pressure switch, thermal switch, or other protection device is shorted and operated forcibly, or parts other than those specified by Mitsubishi Electric are used, fire or explosion may result.
- **To dispose of this product, consult your dealer.**
- **The installer and system specialist shall secure safety against leakage according to local regulation or standards.**
 - Following standards may be applicable if local regulation are not available.
- **Pay a special attention to the place, such as a basement, etc. where refrigeration gas can stay, since refrigeration is heavier than the air.**

1.2. Precautions for devices that use R407C refrigerant

Caution:

- **Do not use the existing refrigerant piping.**
 - The old refrigerant and refrigerant oil in the existing piping contains a large amount of chlorine which may cause the refrigerant oil of the new unit to deteriorate.
- **Use refrigerant piping made of C1220 (CU-DHP) phosphorus deoxidized copper as specified in the JIS H3300 “Copper and copper alloy seamless pipes and tubes”. In addition, be sure that the inner and outer surfaces of the pipes are clean and free**

of hazardous sulphur, oxides, dust/dirt, shaving particles, oils, moisture, or any other contaminant.

- Contaminants on the inside of the refrigerant piping may cause the refrigerant residual oil to deteriorate.
- **Store the piping to be used during installation indoors and keep both ends of the piping sealed until just before brazing. (Store elbows and other joints in a plastic bag.)**
 - If dust, dirt, or water enters the refrigerant cycle, deterioration of the oil and compressor trouble may result.
- **Use ester oil, ether oil or alkylbenzene (small amount) as the refrigerator oil to coat flares and flange connections.**
 - The refrigerator oil will degrade if it is mixed with a large amount of mineral oil.
- **Use liquid refrigerant to fill the system.**
 - If gas refrigerant is used to seal the system, the composition of the refrigerant in the cylinder will change and performance may drop.
- **Do not use a refrigerant other than R407C.**
 - If another refrigerant (R22, etc.) is used, the chlorine in the refrigerant may cause the refrigerator oil to deteriorate.
- **Use a vacuum pump with a reverse flow check valve.**
 - The vacuum pump oil may flow back into the refrigerant cycle and cause the refrigerator oil to deteriorate.
- **Do not use the following tools that are used with conventional refrigerants. (Gauge manifold, charge hose, gas leak detector, reverse flow check valve, refrigerant charge base, vacuum gauge, refrigerant recovery equipment)**
 - If the conventional refrigerant and refrigerator oil are mixed in the R407C, the refrigerant may deteriorate.
 - If water is mixed in the R407C, the refrigerator oil may deteriorate.
 - Since R407C does not contain any chlorine, gas leak detectors for conventional refrigerants will not react to it.
- **Do not use a charging cylinder.**
 - Using a charging cylinder may cause the refrigerant to deteriorate.
- **Be especially careful when managing the tools.**
 - If dust, dirt, or water gets in the refrigerant cycle, the refrigerant may deteriorate.

1.3. Before getting installed

⚠ Caution:

- **Do not install the unit where combustible gas may leak.**
 - If the gas leaks and accumulates around the unit, an explosion may result.
- **Do not use the air conditioner where food, pets, plants, precision instruments, or artwork are kept.**
 - The quality of the food, etc. may deteriorate.
- **Do not use the air conditioner in special environments.**
 - Oil, steam, sulfuric smoke, etc. can significantly reduce the performance of the air conditioner or damage its parts.
- **When installing the unit in a hospital, communication station, or similar place, provide sufficient protection against noise.**
 - The inverter equipment, private power generator, high-frequency medical equipment, or radio communication equipment may cause the air conditioner to operate erroneously, or fail to operate. On the other hand, the air conditioner may affect such equipment by creating noise that disturbs medical treatment or image broadcasting.
- **Do not install the unit on a structure that may cause leakage.**
 - When the room humidity exceeds 80% or when the drain pipe is clogged, condensation may drip from the indoor unit. Perform collective drainage work together with the outdoor unit, as required.

1.4. Before getting installed (moved) - electrical work

⚠ Caution:

- **Ground the unit.**
 - Do not connect the ground wire to gas or water pipes, lightning rods, or telephone ground lines. Improper grounding may result in electric shock.

- **The reverse phase of L lines (L1, L2, L3) can be detected (Error cord : 4103), but the reverse phase of L lines and N line can be not be detected.**
 - The some electric parts should be damaged when power is supplied under the miss wiring.
- **Install the power cable so that tension is not applied to the cable.**
 - Tension may cause the cable to break and generate heat and cause a fire.
- **Install an leak circuit breaker, as required.**
 - If an leak circuit breaker is not installed, electric shock may result.
- **Use power line cables of sufficient current carrying capacity and rating.**
 - Cables that are too small may leak, generate heat, and cause a fire.
- **Use only a circuit breaker and fuse of the specified capacity.**
 - A fuse or circuit breaker of a larger capacity or a steel or copper wire may result in a general unit failure or fire.
- **Do not wash the air conditioner units.**
 - Washing them may cause an electric shock.
- **Be careful that the installation base is not damaged by long use.**
 - If the damage is left uncorrected, the unit may fall and cause personal injury or property damage.
- **Install the drain piping according to this Installation Manual to ensure proper drainage. Wrap thermal insulation around the pipes to prevent condensation.**
 - Improper drain piping may cause water leakage and damage to furniture and other possessions.
- **Be very careful about product transportation.**
 - Only one person should not carry the product if it weighs more than 20 kg.
 - Some products use PP bands for packaging. Do not use any PP bands for a means of transportation. It is dangerous.
 - Do not touch the heat exchanger fins. Doing so may cut your fingers.
 - When transporting the outdoor unit, suspend it at the specified positions on the unit base. Also support the outdoor unit at four points so that it cannot slip sideways.
- **Safely dispose of the packing materials.**
 - Packing materials, such as nails and other metal or wooden parts, may cause stabs or other injuries.
 - Tear apart and throw away plastic packaging bags so that children will not play with them. If children play with a plastic bag which was not torn apart, they face the risk of suffocation.

1.5. Before starting the test run

⚠ Caution:

- **Turn on the power at least 12 hours before starting operation.**
 - Starting operation immediately after turning on the main power switch can result in severe damage to internal parts. Keep the power switch turned on during the operational season.
- **Do not touch the switches with wet fingers.**
 - Touching a switch with wet fingers can cause electric shock.
- **Do not touch the refrigerant pipes during and immediately after operation.**
 - During and immediately after operation, the refrigerant pipes are may be hot and may be cold, depending on the condition of the refrigerant flowing through the refrigerant piping, compressor, and other refrigerant cycle parts. Your hands may suffer burns or frost-bite if you touch the refrigerant pipes.
- **Do not operate the air conditioner with the panels and guards removed.**
 - Rotating, hot, or high-voltage parts can cause injuries.
- **Do not turn off the power immediately after stopping operation.**
 - Always wait at least five minutes before turning off the power. Otherwise, water leakage and trouble may occur.

2. Combination with indoor units

The indoor units connectable to this unit are shown below.

Outdoor unit model name	Total capacity of connected indoor unit models	Quantity of connectable indoor unit	Model name of connectable indoor unit	
PUHY-P400	200 to 520	2 to 20	PMFY-P25 · 32 · 40 · 63	VBM
			PLFY- P32 · 40 · 50 · 63 · 80 · 100 · 125	VKM
PLFY- P25 · 32 · 40 · 50 · 63 · 80 · 100 · 125	VLMD			
PEFY- P25 · 32	VML			
PEFY- P40 · 50 · 63 · 71 · 80 · 100 · 125 · 140 · 200 · 250	VMH			
PUHY-P500	250 to 650		PCFY- P40 · 63 · 100 · 125	VGM
			PKFY- P25	VAM
			PKFY- P32 · 40 · 50	VGM
			PPFY- P25 · 32 · 40 · 50 · 63	VLEM
			PPFY- P25 · 32 · 40 · 50 · 63	VLRM
		PDFY- P25 · 32 · 40 · 50 · 63 · 71 · 80 · 100 · 125	VM	

Note:

- The total capacity of connected indoor unit models represents the total sum of the figures expressed in the indoor model name.
- Combinations in which the total capacity of the connected indoor units exceeds the capacity of the outdoor unit will reduce the capacity of each indoor unit below the rated capacity during simultaneous operation. Therefore, if circumstances allows, combine indoor units within the capacity of the outdoor unit.
- A transmission booster (RP) is required when the number of connected indoor unit models in a cooling system exceeds the number of models specified in the chart below.

* The maximum number of units that can be controlled is determined by the indoor unit model, the type of remote controller and their capabilities.







(*1) Capability of the connected indoor units	Number of connected indoor units that can be connected without a RP.	Remote controller type	
		Remote controller PAR-F 25MA	
		Prior to Ver. E	After Ver. F
	200 or lower	16 (32)	20 (40)
	200 or higher	16 (32)	16 (32)

The number of indoor units and the total number of remote controllers is displayed within the parenthesis ().

*1 If even one unit that is higher than 200 exists in the cooling system, the maximum capacity will be "200 or higher".

3. Confirmation of parts attached

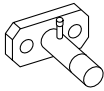
This outdoor unit is attached with the parts below. Please check the quantity for each item.

Name	① Conduit mounting plate	② Conduit mounting plate	③ Conduit mounting plate	④ Tapping screw M4 × 10
Shape				
Model name	PUHY-P400 PUHY-P500	1	1	6
Name	⑤ Connecting pipe	⑥ Packing	⑦ Wire mounting plate	
Shape		 inside ø29, outside ø39		
Model name	PUHY-P400 PUHY-P500	1	1	

*⑤ Connecting pipe is fixed with the unit.

4. Combination with outdoor units

A Super Y (PUHY-P600/650/700/750YSMF-B) is produced when a Constant Capacity Unit (PUHN-P200/250YMF-B) is combined with this unit (PUHY-P400/500YMF-B).

Refer to the installation manual that comes with the Constant Capacity Unit when this unit is used as a Super Y.

Super Y	Variable capacity unit	Constant capacity unit
PUHY-P600YSMF-B	PUHY-P400YMF-B	PUHN-P200YMF-B
PUHY-P650YSMF-B		PUHN-P250YMF-B
PUHY-P700YSMF-B	PUHY-P500YMF-B	PUHN-P200YMF-B
PUHY-P750YSMF-B		PUHN-P250YMF-B

5. Selection of installation site

Select space for installing outdoor unit, which will meet the following conditions:

- no direct thermal radiation from other heat sources
- no possibility of annoying neighbors by noise from unit
- no exposition to strong wind
- with strength which bears weight of unit
- note that drain flows out of unit when heating
- with space for air passage and service work shown below

Because of the possibility of fire, do not install unit to the space where generation, inflow, stagnation, and leak of combustible gas is expected.

- Avoid unit installation in a place where acidic solution and spray (sulfur) are often used.
- When having cooling operation at an outside air temperature of below 10°C, in order to obtain steady operation of unit, select an installation site not exposed directly to rain and snow, or install air outlet and inlet ducts. (Refer to Page 11.) Install the outdoor unit at the same position on the same floor, or above, the indoor unit. (See the figure at the right.)
- Do not use unit in any special environment where oil, steam and sulfuric acid exist.

Installation restriction on outdoor unit when cooling operation is performed when the outdoor air temperature is 10°C or lower

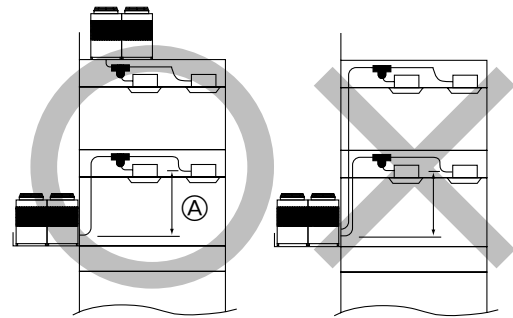

(Same floor as indoor unit, or floor above)

Ⓐ 4 m or less

6. Space required around unit

6.1. Individual installation

Basic space required

A space of at least 250 mm is necessary at the back for inlet air. Taking servicing, etc. from the rear into account, a space of about 450 mm should be provided, the same as at the front.

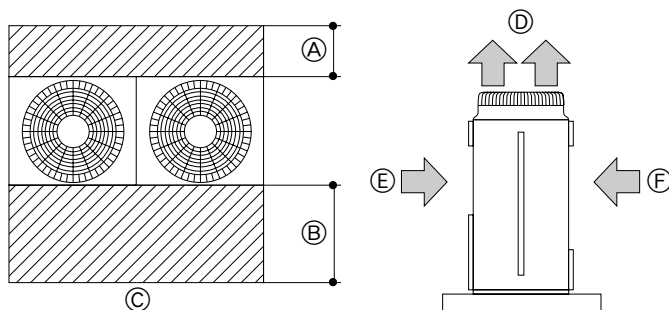

<Top view>

<Side view>

- Ⓐ 250 mm or more
- Ⓑ 450 mm or more
- Ⓒ Front (outside of machine room)
- Ⓓ Top discharge (open in principle)
- Ⓔ Front inlet (open in principle)
- Ⓕ Rear inlet (open in principle)

When inlet air enters from right and left sides of unit

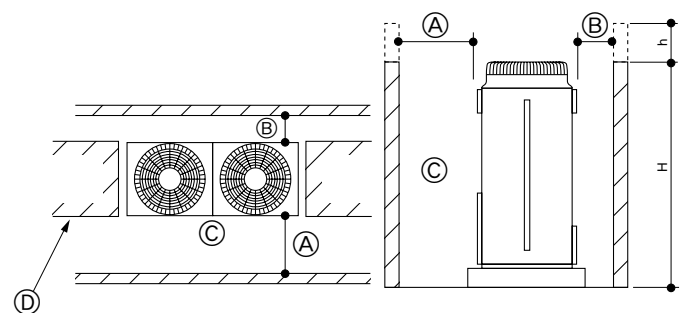

<Side view>

- Ⓐ L1 or more
- Ⓑ L2 or more
- Ⓒ Front
- Ⓓ No restrictions on wall height (left and right)

Note:

- Wall heights (H) of the front and the back sides shall be within overall height of unit.
- When the total height is exceeded, add the "h" dimension of the figure above to L1 and L2 in the table above.

Model	L1	L2
PUHY-P400	450	250
PUHY-P500		

When unit is surrounded by walls

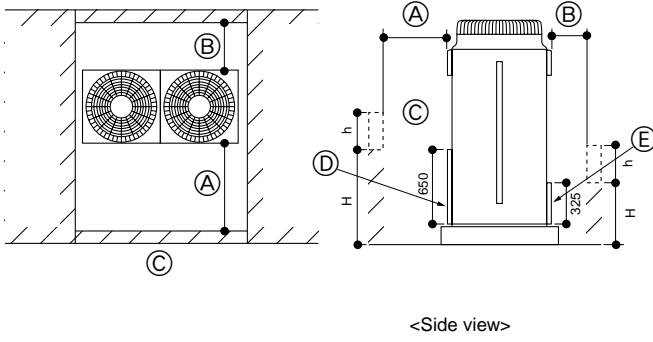

- Ⓐ L1 or more
- Ⓑ L2 or more
- Ⓒ Front
- Ⓓ Front panel
- Ⓔ Rear panel

Note:

- Wall heights (H) of the front and the back sides shall be within height of front panel and rear panel.
- If the panel height is exceeded, add the “h” dimension of the figure above to L1 and L2 in the table above.

Model	L1	L2
PUHY-P400	450	250
PUHY-P500	450	250

Example: When h is 100

The L1 dimension becomes 450+100=550 mm.

When there is an obstruction above the unit

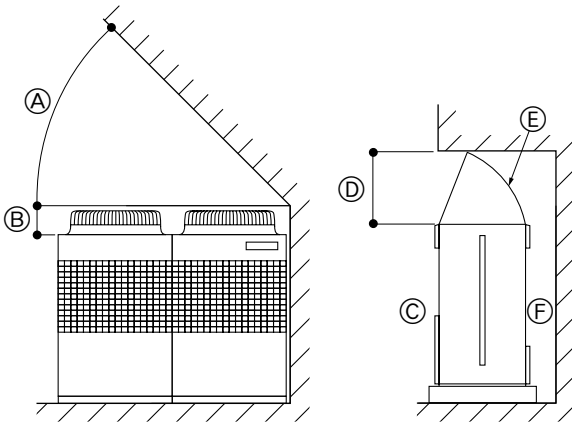

When there is little space up to an obstruction

- Ⓐ 45° or more
- Ⓑ 300 mm or more
- Ⓒ Front
- Ⓓ 1000 mm or more
- Ⓔ Air outlet guide (Procured at the site)
- Ⓕ Rear

6.2. Collective installation and continuous installation

Space required for collective installation and continuous installation: When installing several units, leave the space between each block as shown below considering passage for air and people.

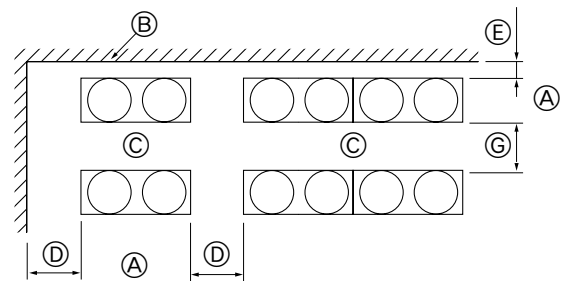
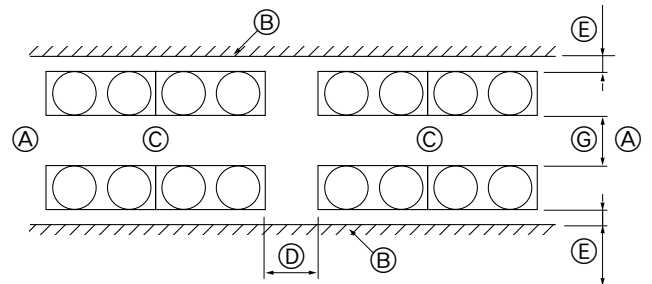
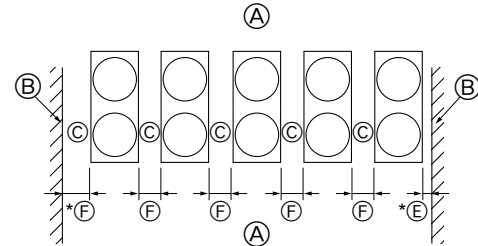
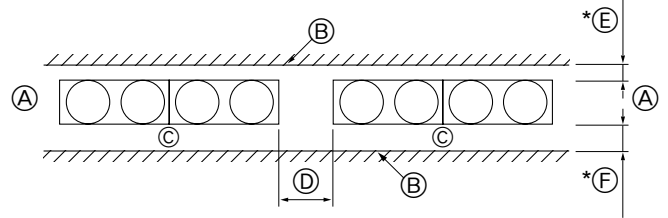

- Ⓐ (Must be open)
- Ⓑ Wall height (H)
- Ⓒ Front
- Ⓓ 1000 mm or more
- Ⓔ 250 mm or more
- Ⓕ 450 mm or more
- Ⓖ 900 mm or more

Note:

- Open in the two directions.
- In case wall height (H) exceeds overall height of unit, add “h” dimension (h=wall height <H> – overall height of unit) to * marked dimension.
- If there is a wall at both the front and the rear of the unit, install up to three units consecutively in the side direction and provide a space of 1000 mm or more as inlet space/passage space for each three units.

7. Lifting method and weight of product

- When carrying the unit suspended, pass the ropes under the unit and use the two suspension points each at the front and rear.
- Always lift the unit with ropes attached at four points so that impact is not applied to the unit.
- Attach the ropes to the unit at an angle of 40° or less.
- Use two ropes at least 8 m long.

Weight of product:

PUHY-P400	PUHY-P500
455 kg	475 kg

⚠ Caution:

Be very careful to carry product.

- Do not have only one person to carry product if it is more than 20 kg.
- PP bands are used to pack some products. Do not use them as a mean for transportation because they are dangerous.
- Do not touch heat exchanger fins with your bare hands. Otherwise you may get a cut in your hands.
- Tear plastic packaging bag and scrap it so that children cannot play with it. Otherwise plastic packaging bag may suffocate children to death.
- When carrying in outdoor unit, be sure to support it at four points. Carrying in and lifting with 3-point support may make outdoor unit unstable, resulting in a fall of it.

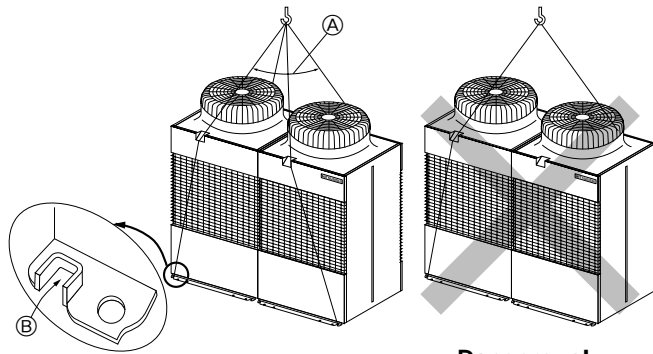

Ⓐ 40° or less

Ⓑ Rope suspension part

8. Installation of unit

8.1. Location of anchor bolt

- Individual installation

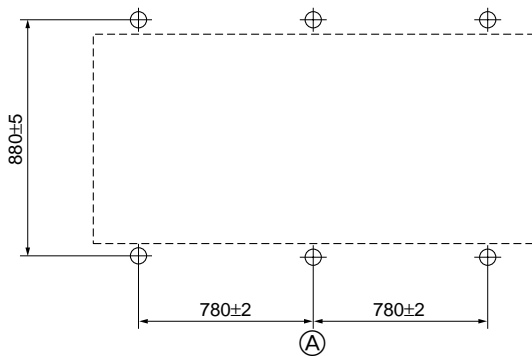

- Example of collective installation

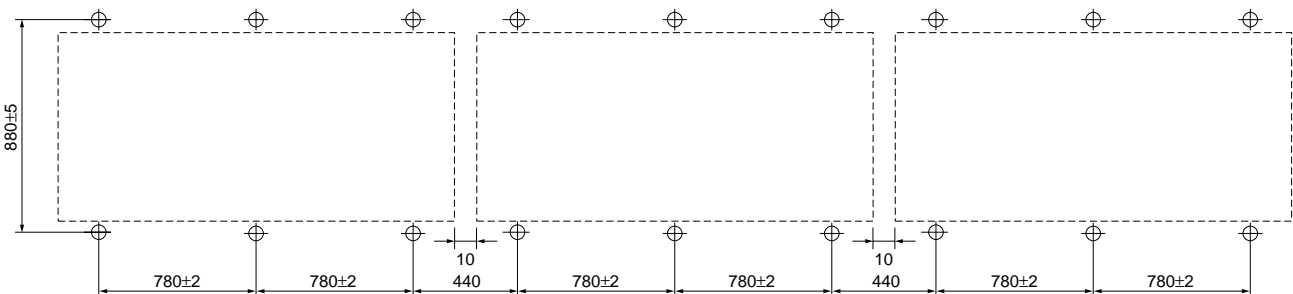

For collective installation, provide a 10 mm gap between units.

Ⓐ (Service side)

8.2. Installation

- Fix unit tightly with bolts as shown below so that unit will not fall down due to earthquake or gust.
- Use concrete or angle for foundation of unit.
- Vibration may be transmitted to the installation section and noise and vibration may be generated from the floor and walls, depending on the installation conditions. Therefore, provide ample vibrationproofing (cushion pads, cushion frame, etc.).

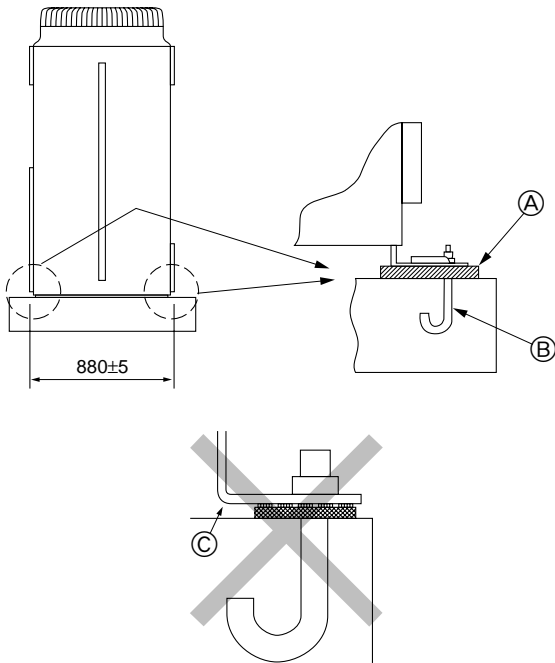

Down piping and down wiring precautions

When down piping and down wiring are performed, be sure that foundation and base work does not block the base through holes. When down piping is performed, make the foundation at least 100 mm high so that the piping can pass under the bottom of the unit.

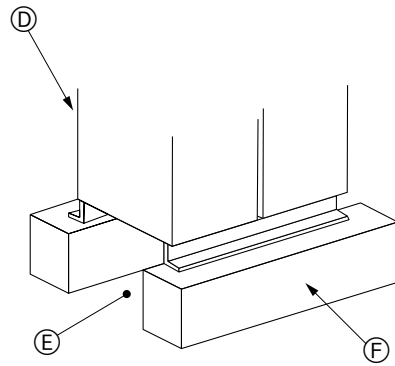

- (A) Be sure that the corners are firmly seated. If the corners are not firmly seated, the installation feet may be bent.
- (B) M10 anchor bolt procured at the site
- (C) Corner is not seated.
- (D) Unit
(Provide ample vibrationproofing between the unit and the foundation by using cushion pads, cushion frame, etc.)
- (E) Piping and wiring space (Bottom piping, bottom wiring)
- (F) Concrete foundation

⚠ Warning:

- **Be sure to install unit in a place strong enough to withstand its weight.**
Any lack of strength may cause unit to fall down, resulting in a personal injury.
- **Have installation work in order to protect against a strong wind and earthquake.**
Any installation deficiency may cause unit to fall down, resulting in a personal injury.

When building the foundation, give full attention to the floor strength, drain water disposal <during operation, drain water flows out of the unit>, and piping and wiring routes.

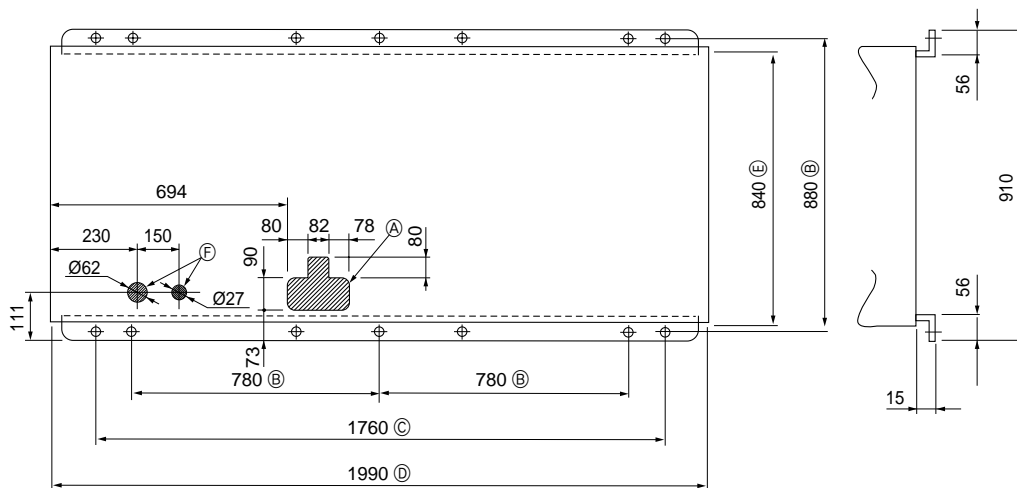

- (A) Bottom piping through hole
- (B) (bolt hole)
- (C) (bolt hole for old models)
- (D) (unit width)
- (E) (unit depth)
- (F) Bottom wiring through hole

8.3. Connecting direction for refrigerant piping

Two connecting directions are available for refrigerant piping of the outdoor unit, bottom piping and front piping, as shown below:

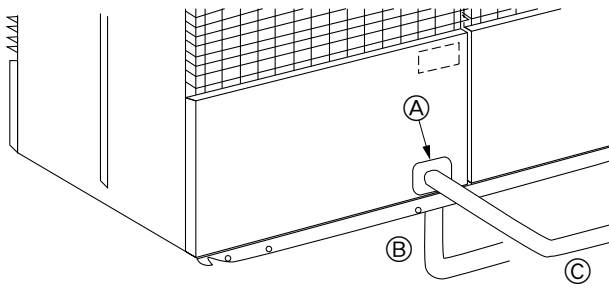

- Ⓐ Knock-out hole
- Ⓑ Bottom piping
- Ⓒ Front piping

Note:
In the case of bottom piping, build a 100 mm or higher foundation so that piping will go through the bottom of the unit.

8.4. Noise level

(50/60Hz)

PUHY-P400	PUHY-P500
60/61 dB(A)	

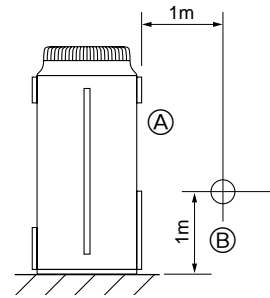

- Ⓐ Front
- Ⓑ Measuring point

Measuring location: a room free from echoes and reverberations

9. Caution for snow and seasonal wind

In cold and/or snowy areas, sufficient countermeasures to wind and snow damages should be taken for operating unit in normal and good condition in winter time. Even in the other areas, full consideration is required for installation of unit in order to prevent abnormal operations caused by seasonal wind or snow. **When rain and snow directly fall on unit in the case of air-conditioning operations in 10 or less degrees centigrade outdoor air, mount inlet and outlet ducts on unit for assuring stable operations.**

9.1. Snow and seasonal wind

- Prevention of wind and snow damages in cold or snowy areas:
Refer to the figure of snow hood shown below:
- Snow hood

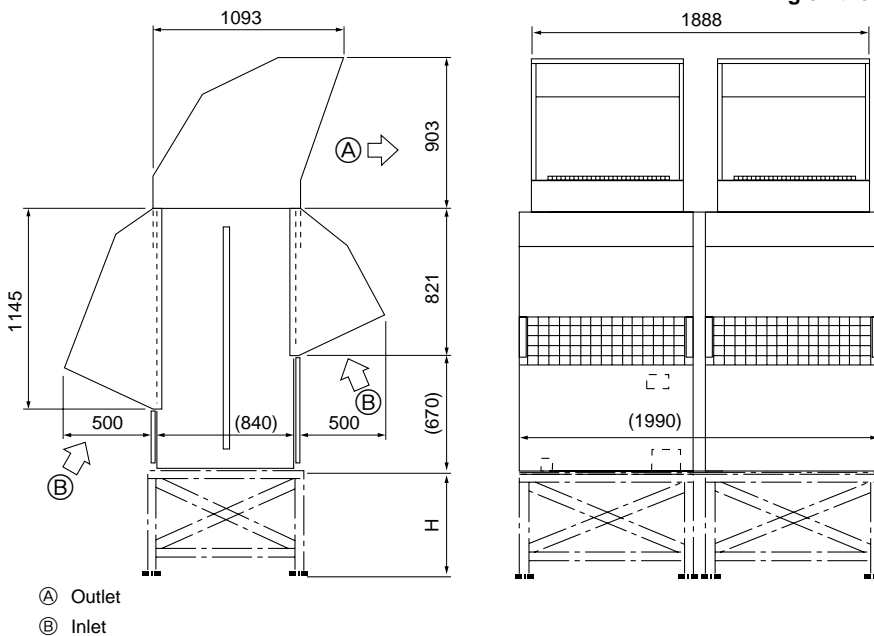

Note:

1. Height of frame base for snow damage prevention (H) shall be twice as high as expected snowfall. Width of frame base shall not exceed that of the unit. The frame base shall be made of angle steel, etc., and designed so that snow and wind slip through the structure. (If frame base is too wide, snow will be accumulated on it.)
2. Install unit so that seasonal wind will not directly lash against openings of inlet and outlet ducts.
3. Build frame base at customer referring to this figure.
Material : Galvanized steel plate 1.2T
Painting : Overall painting with polyester powder
Color : Munsell 5Y8/1 (same as that of unit)
4. When the unit is used in a cold region and the heating operation is continuously performed for a long time when the outside air temperature is below freezing, install a heater to the unit base or take other appropriate measures to prevent water from freezing on the base.

9.2. Countermeasure to seasonal wind

Referring to the figure shown below, take appropriate measures which will suit the actual situation of the place for installation.

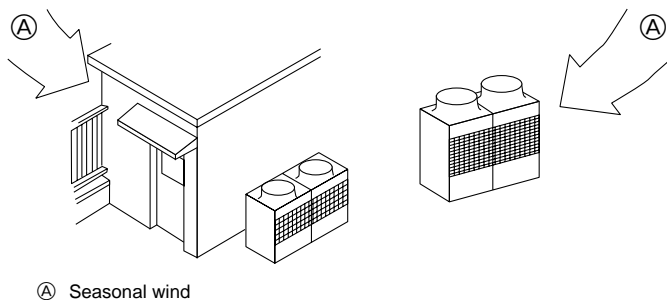

10. Refrigerant piping installation

Connecting the piping is a terminal-branch type in which refrigerant piping from the outdoor unit is branched at the terminal and connected to each of the indoor units.

The method of connection consists of flare connections at the indoor units, flange connections for the piping of the outdoor unit and flare connections for the liquid piping. Note that the branched sections are brazed.

⚠ Warning:

Always use extreme care to prevent the refrigerant gas (R22) from leaking while using fire or flame. If the refrigerant gas comes in contact with the flame from any source, such as a gas stove, it breaks down and generates a poisonous gas which can cause gas poisoning. Never weld in an unventilated room. Always conduct an inspection for gas leakage after installation of the refrigerant piping has been completed.

10.1. Areas of caution

- ① Use the following materials for refrigeration piping.
 - Material: Seamless phosphorous deoxidized copper pipe, C1220T-OL or C1220T-O (Note: C1220T-OL is preferred.)
 - Size: Refer to Pages 13 to 14.
- ② Commercially available piping often contains dust and other materials. Always blow it clean with a dry inert gas.
- ③ Use care to prevent dust, water or other contaminants from entering the piping during installation.
- ④ Reduce the number of bending portions as much as possible, and make bending radius as big as possible.
- ⑤ Always use the branch piping set shown below, which are sold separately.

Branch pipe set name					
Line branching			Header branching		
Total of units down-stream less than 160	Total of units down-stream 161 to 330	Total of units down-stream more than 331	4 branching	7 branching	10 branching
CMY-Y102S-F	CMY-Y102L-F	CMY-Y202-F	CMY-Y104-E	CMY-Y107-E	CMY-Y1010-E

- ⑥ If the diameters of the branch piping of the designated refrigerant piping differs, use a pipe cutter to cut the connecting section and then use an adapter for connecting different diameters to connect the piping.
- ⑦ Always observe the restrictions on the refrigerant piping (such as rated length, the difference between high/low pressures, and piping diameter). Failure to do so can result in equipment failure or a decline in heating/cooling performance.
- ⑧ A second branch cannot be made after a header branch. (These are shown by X.)

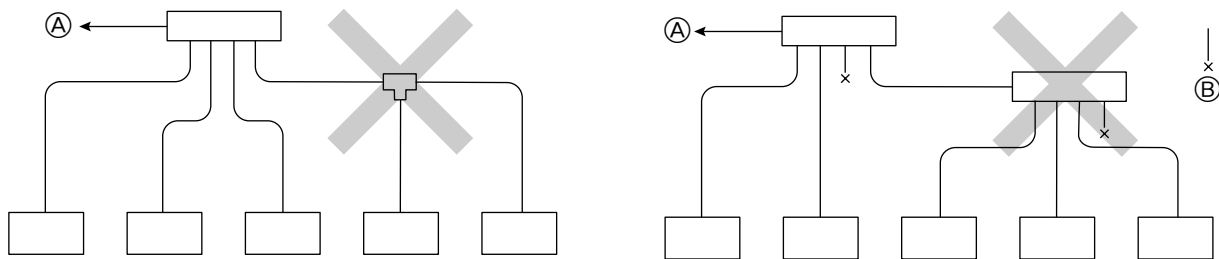

- Ⓐ To Outdoor Unit
 Ⓑ Capped Piping

- ⑨ Always use good-quality materials for brazing.
- ⑩ The City Multi Series Y will stop due an abnormality due to excessive or insufficient coolant. At such a time, always properly charge the unit. When servicing, always check the notes concerning pipe length and amount of additional refrigerant at both locations, the refrigerant volume calculation table on the back of the service panel and the additional refrigerant section on the labels for the combined number of indoor units. (Refer to Pages 13 to 14.)
- ⑪ **Use liquid refrigerant to fill the system.**
- ⑫ Never use refrigerant to perform an air purge. Always evacuate using a vacuum pump.
- ⑬ Always insulate the piping properly. Insufficient insulation will result in a decline in heating/cooling performance, water drops from condensation and other such problems. (Refer to Pages 21 to 22.)
- ⑭ When connecting the refrigerant piping, make sure the ball valve of the outdoor unit is completely closed (the factory setting) and do not operate it until the refrigerant piping for the outdoor and indoor units has been connected, a refrigerant leakage test has been performed and the evacuation process has been completed.
- ⑮ Always use a non-oxidizing brazing material for brazing the parts. If a non-oxidizing brazing material is not used, it could cause clogging or damage to the compressor unit. (Details of the piping connections and valve operation can be found on Pages 15 to 16.)
- ⑯ **Never perform outdoor unit piping connection work when it is raining.**

⚠ Warning:

When installing and moving the air conditioner to another site, do not charge the it with a refrigerant different from the refrigerant (R407C) specified on the unit.

- If a different refrigerant or air is mixed with the original refrigerant, the refrigerant cycle may malfunction and the unit may be damaged.

⚠ Caution:

- **Use refrigerant piping made of C1220T-OL phosphorus deoxidized copper. In addition, be sure that the inner and outer surfaces of the pipes are clean and free of hazardous sulphur, oxides, dust/dirt, shaving particles, oils, moisture, or any other contaminant.**
 - Contaminants on the inside of the refrigerant piping may cause the refrigerant residual oil to deteriorate.
- **Use liquid refrigerant for sealing.**
 - Sealing with gas refrigerant will change the composition of the refrigerant in the cylinder and reduce the unit's performance.
- **Never use existing refrigerant piping.**
 - The large amount of chlorine in conventional refrigerant and refrigerator oil in the existing piping will cause the new refrigerant to deteriorate.
- **Store the piping to be used during installation indoors and keep both ends of the piping sealed until just before brazing.**
 - If dust, dirt, or water gets into the refrigerant cycle, the oil will deteriorate and the compressor may fail.
- **Do not use a charging cylinder.**
 - Using a charging cylinder may cause the refrigerant to deteriorate.

10.2. Refrigerant piping system

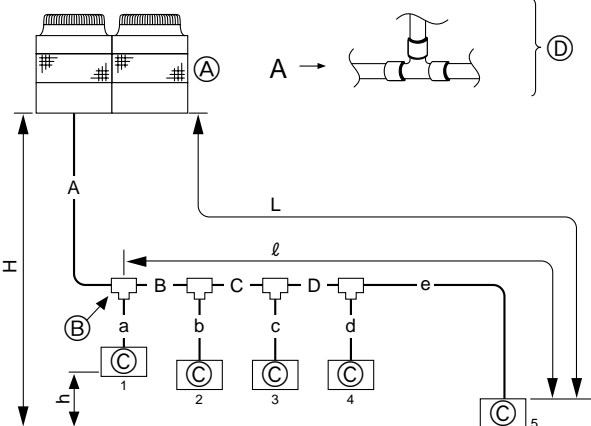
<p>Line-Branch Method Connection Examples (Connecting to Five Indoor Units)</p>	 <p>Note: The model total for downstream units shown in the table below is the model total when viewed from Point A in the drawing above.</p> <p>Ⓐ Outdoor Unit Ⓑ First Branch The first branch on the outdoor unit must be the CMY-Y202-F. Ⓒ Indoor unit Ⓓ To downstream units</p>																																																							
<table border="1"> <tr> <td rowspan="2">Permissible Length</td> <td>Total Piping Length</td> <td>A+B+C+D+a+b+c+d+e is 220 m or less</td> </tr> <tr> <td>Farthest Piping Length (L)</td> <td>A+B+C+D+e is 100 m or less</td> </tr> <tr> <td></td> <td>Farthest Piping Length After First Branch (ℓ)</td> <td>B+C+D+e is 30 m or less</td> </tr> <tr> <td rowspan="2">Permissible High/Low Difference</td> <td>High/Low Difference in Indoor/Outdoor Section (H)</td> <td>50 m or less (If the outdoor unit is lower, 40 m or less)</td> </tr> <tr> <td>High/Low Difference in Indoor/Indoor Section (h)</td> <td>15 m or less</td> </tr> </table>	Permissible Length	Total Piping Length	A+B+C+D+a+b+c+d+e is 220 m or less	Farthest Piping Length (L)	A+B+C+D+e is 100 m or less		Farthest Piping Length After First Branch (ℓ)	B+C+D+e is 30 m or less	Permissible High/Low Difference	High/Low Difference in Indoor/Outdoor Section (H)	50 m or less (If the outdoor unit is lower, 40 m or less)	High/Low Difference in Indoor/Indoor Section (h)	15 m or less	<p>■ Selecting the Refrigerant Branch Kit Use the table to the right to make the selection based on the model total of indoor units downstream from the branch section.</p> <table border="1"> <thead> <tr> <th>Downstream Unit Model Total</th> <th>Branch Kit Model</th> </tr> </thead> <tbody> <tr> <td>160 or less</td> <td>CMY-Y102S-F</td> </tr> <tr> <td>161 to 330</td> <td>CMY-Y102L-F</td> </tr> <tr> <td>331 or more</td> <td>CMY-Y202-F</td> </tr> </tbody> </table>	Downstream Unit Model Total	Branch Kit Model	160 or less	CMY-Y102S-F	161 to 330	CMY-Y102L-F	331 or more	CMY-Y202-F																																		
Permissible Length		Total Piping Length	A+B+C+D+a+b+c+d+e is 220 m or less																																																					
	Farthest Piping Length (L)	A+B+C+D+e is 100 m or less																																																						
	Farthest Piping Length After First Branch (ℓ)	B+C+D+e is 30 m or less																																																						
Permissible High/Low Difference	High/Low Difference in Indoor/Outdoor Section (H)	50 m or less (If the outdoor unit is lower, 40 m or less)																																																						
	High/Low Difference in Indoor/Indoor Section (h)	15 m or less																																																						
Downstream Unit Model Total	Branch Kit Model																																																							
160 or less	CMY-Y102S-F																																																							
161 to 330	CMY-Y102L-F																																																							
331 or more	CMY-Y202-F																																																							
<p>■ Select Each Section of Refrigerant Piping</p> <p>(1) Section From Outdoor Unit to First Branch (A) (2) Sections From Branch to Indoor Unit (a,b,c,d,e) (3) Section From Branch to Branch (B, C, D)</p> <p>Each Section of Piping</p> <p>Select the size from the table to the right.</p>	<p>(1) Refrigerant Piping Diameter In Section From Outdoor Unit to First Branch (Outdoor Unit Piping Diameter)</p> <table border="1"> <thead> <tr> <th rowspan="2">Model</th> <th colspan="2">Piping Diameter (mm)</th> </tr> <tr> <th>Liquid Line</th> <th>Gas Line</th> </tr> </thead> <tbody> <tr> <td rowspan="2">PUHY-P400</td> <td>ø15.88</td> <td>ø31.75</td> </tr> <tr> <td>ø15.88</td> <td>ø38.1</td> </tr> </tbody> </table> <p>(2) Refrigerant Piping Diameter In Section From Branch to Indoor Unit (Indoor Unit Piping Diameter)</p> <table border="1"> <thead> <tr> <th rowspan="2">Model number</th> <th colspan="2">Piping dia. (mm)</th> </tr> <tr> <th>Liquid Line</th> <th>Gas Line</th> </tr> </thead> <tbody> <tr> <td rowspan="2">25 · 32 · 40</td> <td>ø6.35</td> <td>ø12.7</td> </tr> <tr> <td>ø9.52</td> <td>ø15.88</td> </tr> <tr> <td rowspan="2">50 · 63 · 71 · 80</td> <td>ø9.52</td> <td>ø19.05</td> </tr> <tr> <td>ø12.7</td> <td>ø25.4</td> </tr> <tr> <td rowspan="2">100 · 125 · 140</td> <td>ø12.7</td> <td>ø28.58</td> </tr> <tr> <td>ø15.88</td> <td>ø38.1</td> </tr> </tbody> </table> <p>(3) Refrigerant Piping Diameter In Section From Branch to Branch</p> <table border="1"> <thead> <tr> <th>Downstream Unit Model Total</th> <th>Liquid Line (mm)</th> <th>Gas Line (mm)</th> </tr> </thead> <tbody> <tr> <td>80 or less</td> <td>ø9.52</td> <td>ø15.88</td> </tr> <tr> <td>81 to 160</td> <td>ø12.7</td> <td>ø19.05</td> </tr> <tr> <td>161 to 330</td> <td>ø12.7</td> <td>ø25.4</td> </tr> <tr> <td>331 to 480</td> <td>ø15.88</td> <td>ø31.75</td> </tr> <tr> <td>481 or more</td> <td>ø15.88</td> <td>ø38.1</td> </tr> </tbody> </table>	Model	Piping Diameter (mm)		Liquid Line	Gas Line	PUHY-P400	ø15.88	ø31.75	ø15.88	ø38.1	Model number	Piping dia. (mm)		Liquid Line	Gas Line	25 · 32 · 40	ø6.35	ø12.7	ø9.52	ø15.88	50 · 63 · 71 · 80	ø9.52	ø19.05	ø12.7	ø25.4	100 · 125 · 140	ø12.7	ø28.58	ø15.88	ø38.1	Downstream Unit Model Total	Liquid Line (mm)	Gas Line (mm)	80 or less	ø9.52	ø15.88	81 to 160	ø12.7	ø19.05	161 to 330	ø12.7	ø25.4	331 to 480	ø15.88	ø31.75	481 or more	ø15.88	ø38.1							
Model	Piping Diameter (mm)																																																							
	Liquid Line	Gas Line																																																						
PUHY-P400	ø15.88	ø31.75																																																						
	ø15.88	ø38.1																																																						
Model number	Piping dia. (mm)																																																							
	Liquid Line	Gas Line																																																						
25 · 32 · 40	ø6.35	ø12.7																																																						
	ø9.52	ø15.88																																																						
50 · 63 · 71 · 80	ø9.52	ø19.05																																																						
	ø12.7	ø25.4																																																						
100 · 125 · 140	ø12.7	ø28.58																																																						
	ø15.88	ø38.1																																																						
Downstream Unit Model Total	Liquid Line (mm)	Gas Line (mm)																																																						
80 or less	ø9.52	ø15.88																																																						
81 to 160	ø12.7	ø19.05																																																						
161 to 330	ø12.7	ø25.4																																																						
331 to 480	ø15.88	ø31.75																																																						
481 or more	ø15.88	ø38.1																																																						
<p>■ Additional Refrigerant Charge At the time of shipping, the outdoor unit PUHY-P400 is charged with 16 kg of refrigerant and the PUHY-P500 is charged with 22 kg. As this charge does not include the amount needed for extended piping, additional charging for each refrigerant line will be required on site. In order that future servicing may be properly provided, always keep a record of the size and length of each refrigerant line and the amount of additional charge by writing it in the space provided on the outdoor unit.</p> <p>■ Calculation of Additional Refrigerant Charge</p> <ul style="list-style-type: none"> Calculate the amount of additional charge based on the length of the piping extension and the size of the refrigerant line. Use the table to the right as guide to calculating the amount of additional charging and charge the system according. If the calculation results of the calculation result in a fraction of less than 0.1 kg, round up to the next 0.1 kg. For example, if the result of the calculation was 16.76 kg, round the result up to 16.8 kg. 	<p><Additional Charge></p> <table border="1"> <tr> <td>Liquid pipe size Total length of ø15.88 × 0.25</td> <td>+</td> <td>Liquid pipe size Total length of ø12.7 × 0.12</td> <td>+</td> <td>Liquid pipe size Total length of ø9.52 × 0.06</td> <td>+</td> <td>Liquid pipe size Total length of ø6.35 × 0.024</td> <td>+</td> <td>α</td> </tr> <tr> <td>(m) × 0.25 (kg/m)</td> <td></td> <td>(m) × 0.12 (kg/m)</td> <td></td> <td>(m) × 0.06 (kg/m)</td> <td></td> <td>(m) × 0.024 (kg/m)</td> <td></td> <td></td> </tr> </table> <p><Example></p> <table border="1"> <tr> <td>Indoor 1 : 125</td> <td>A : ø15.88</td> <td>40 m</td> <td>a : ø9.52</td> <td>10 m</td> </tr> <tr> <td>2 : 100</td> <td>B : ø12.7</td> <td>10 m</td> <td>b : ø9.52</td> <td>10 m</td> </tr> <tr> <td>3 : 50</td> <td>C : ø12.7</td> <td>5 m</td> <td>c : ø9.52</td> <td>10 m</td> </tr> <tr> <td>4 : 32</td> <td>D : ø9.52</td> <td>5 m</td> <td>d : ø6.35</td> <td>5 m</td> </tr> <tr> <td>5 : 32</td> <td></td> <td></td> <td>e : ø6.35</td> <td>10 m</td> </tr> </table> <p>At the conditions below:</p> <p>The total length of each liquid line is as follows: ø15.88 : A = 40 m ø12.7 : B + C = 10 + 5 = 15 m ø9.52 : D + a + b + c = 5 + 10 + 10 + 10 = 35 m ø6.35 : d + e = 5 + 10 = 15 m</p> <p>Therefore, <Calculation example> Additional refrigerant charge = 40 × 0.25 + 15 × 0.12 + 35 × 0.06 + 15 × 0.024 + 2.5 = 16.8 kg</p> <p>Value of α</p> <table border="1"> <thead> <tr> <th>Total capacity of connecting indoor units</th> <th>α</th> </tr> </thead> <tbody> <tr> <td>to Model 80</td> <td>1.0 kg</td> </tr> <tr> <td>Models 81 to 160</td> <td>1.5 kg</td> </tr> <tr> <td>Models 161 to 330</td> <td>2.0 kg</td> </tr> <tr> <td>Models 331 to 480</td> <td>2.5 kg</td> </tr> <tr> <td>Models 481 or more</td> <td>3.0 kg</td> </tr> </tbody> </table>	Liquid pipe size Total length of ø15.88 × 0.25	+	Liquid pipe size Total length of ø12.7 × 0.12	+	Liquid pipe size Total length of ø9.52 × 0.06	+	Liquid pipe size Total length of ø6.35 × 0.024	+	α	(m) × 0.25 (kg/m)		(m) × 0.12 (kg/m)		(m) × 0.06 (kg/m)		(m) × 0.024 (kg/m)			Indoor 1 : 125	A : ø15.88	40 m	a : ø9.52	10 m	2 : 100	B : ø12.7	10 m	b : ø9.52	10 m	3 : 50	C : ø12.7	5 m	c : ø9.52	10 m	4 : 32	D : ø9.52	5 m	d : ø6.35	5 m	5 : 32			e : ø6.35	10 m	Total capacity of connecting indoor units	α	to Model 80	1.0 kg	Models 81 to 160	1.5 kg	Models 161 to 330	2.0 kg	Models 331 to 480	2.5 kg	Models 481 or more	3.0 kg
Liquid pipe size Total length of ø15.88 × 0.25	+	Liquid pipe size Total length of ø12.7 × 0.12	+	Liquid pipe size Total length of ø9.52 × 0.06	+	Liquid pipe size Total length of ø6.35 × 0.024	+	α																																																
(m) × 0.25 (kg/m)		(m) × 0.12 (kg/m)		(m) × 0.06 (kg/m)		(m) × 0.024 (kg/m)																																																		
Indoor 1 : 125	A : ø15.88	40 m	a : ø9.52	10 m																																																				
2 : 100	B : ø12.7	10 m	b : ø9.52	10 m																																																				
3 : 50	C : ø12.7	5 m	c : ø9.52	10 m																																																				
4 : 32	D : ø9.52	5 m	d : ø6.35	5 m																																																				
5 : 32			e : ø6.35	10 m																																																				
Total capacity of connecting indoor units	α																																																							
to Model 80	1.0 kg																																																							
Models 81 to 160	1.5 kg																																																							
Models 161 to 330	2.0 kg																																																							
Models 331 to 480	2.5 kg																																																							
Models 481 or more	3.0 kg																																																							

Multiple Line/Header Connection Example
(When Connecting Five Indoor Units)

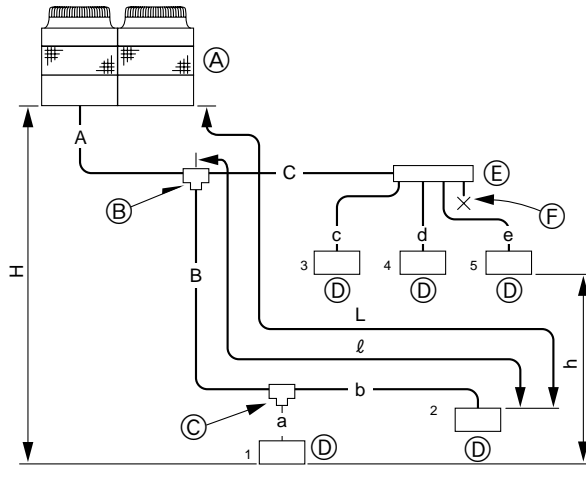

- Note:
- Branch piping cannot be used again after the header branch.
 - The model total for downstream units shown in the table below is the model total when viewed from Point A in the drawing above.
- Ⓐ Outdoor Unit
 - Ⓑ First Branch (Branch Joint)
The first branch must be the CMY-Y202-F when the outdoor unit and header branch are to be used.
 - Ⓒ Branch Joint
 - Ⓓ Indoor Unit
 - Ⓔ Branch Header
 - Ⓕ Cap

Permissible Length	Total Piping Length	A+B+C+a+b+c+d+e is 220 m or less
	Farthest Piping Length (L)	A+B+b is 100 m or less
	Farthest Piping Length After First Branch (ℓ)	B+b is 30 m or less
Permissible High/Low Difference	High/Low Difference in Indoor/Outdoor Section (H)	50 m or less (If the outdoor unit is lower, 40 m or less)
	High/Low Difference in Indoor/Indoor Section (h)	15 m or less

■ Selecting the Refrigerant Branch Kit
Use the table to the right to make the selection based on the model total of indoor units downstream from the branch section or on the number of indoor units to be connected on the header branch.

Select the branch kit, sold separately, from the table below. (Each kit contains a refrigerant and gas piping set.)

Line branching			Header branching		
Total of units downstream less than 160	Total of units downstream 161 to 330	Total of units downstream more than 331	4 branching header	7 branching header	10 branching header
CMY-Y102S-F	CMY-Y102L-F	CMY-Y202-F	CMY-Y104-E	CMY-Y107-E	CMY-Y1010-E

■ Select Each Section of Refrigerant Piping

(1) Section From Outdoor Unit to First Branch (A)
(2) Sections From Branch to Indoor Unit (a,b,c,d,e)
(3) Section From Branch to Branch (B, C)

Each Section of Piping

Select the size from the table to the right.

(1) Refrigerant Piping Diameter In Section From Outdoor Unit to First Branch (Outdoor Unit Piping Diameter)

Model	Piping Diameter (mm)	
	Liquid Line	Gas Line
PUHY-P400	ø15.88	ø31.75
	ø15.88	ø38.1

(2) Refrigerant Piping Diameter In Section From Branch to Indoor Unit (Indoor Unit Piping Diameter)

Model number	Piping dia. (mm)	
	Liquid Line	Gas Line
25 · 32 · 40	ø6.35	ø12.7
	ø9.52	ø15.88
50 · 63 · 71 · 80	ø9.52	ø19.05
	ø12.7	ø25.4
100 · 125 · 140	ø12.7	ø28.58
	ø15.88	ø38.1

(3) Refrigerant Piping Diameter In Section From Branch to Branch

Downstream Unit Model Total	Liquid Line (mm)	Gas Line (mm)
80 or less	ø9.52	ø15.88
81 to 160	ø12.7	ø19.05
161 to 330	ø12.7	ø25.4
331 to 480	ø15.88	ø31.75
481 or more	ø15.88	ø38.1

■ Additional Refrigerant Charge
At the time of shipping, the outdoor unit PUHY-P400 is charged with 16 kg of refrigerant and the PUHY-P500 is charged with 22 kg. As this charge does not include the amount needed for extended piping, additional charging for each refrigerant line will be required on site. In order that future servicing may be properly provided, always keep a record of the size and length of each refrigerant line and the amount of additional charge by writing it in the space provided on the outdoor unit.

<Additional Charge>

Liquid pipe size Total length of ø15.88 × 0.25	+	Liquid pipe size Total length of ø12.7 × 0.12	+	Liquid pipe size Total length of ø9.52 × 0.06	+	Liquid pipe size Total length of ø6.35 × 0.024	+	α
(m) × 0.25 (kg/m)		(m) × 0.12 (kg/m)		(m) × 0.06 (kg/m)		(m) × 0.024 (kg/m)		

<Example>

Indoor 1 : 125	A : ø15.88	30 m	a : ø9.52	10 m	} At the conditions below:
2 : 100	B : ø12.7	10 m	b : ø9.52	20 m	
3 : 40	C : ø12.7	15 m	c : ø6.35	10 m	
4 : 32			d : ø6.35	10 m	
5 : 32			e : ø6.35	10 m	

The total length of each liquid line is as follows:

- ø15.88 : A = 30 m
- ø12.7 : B + C = 10 + 15 = 25 m
- ø9.52 : a + b = 10 + 20 = 30 m
- ø6.35 : c + d + e = 10 + 10 + 10 = 30 m

Therefore,
<Calculation example>

Additional refrigerant charge = 30 × 0.25 + 15 × 0.12 + 30 × 0.06 + 30 × 0.024 + 2.5 = 14.4 kg

Value of α

Total capacity of connecting indoor units	α
to Model 80	1.0 kg
Models 81 to 160	1.5 kg
Models 161 to 330	2.0 kg
Models 331 to 480	2.5 kg
Models 481 or more	3.0 kg

10.3. Caution for piping connection/valve operation

- Conduct piping connection and valve operation accurately by following the figure below.
- The gas side connecting pipe is being assembled for shipment. (See the figure at the right.)
 - ① For brazing to the connecting pipe with flange, remove the connecting pipe with flange from the ball valve, and braze it at the outside of the unit.
 - ② During the time when removing the connecting pipe with flange, remove the seal attached on the back side of this sheet and paste it onto the flange surface of the ball valve to prevent the entry of dust into the valve.
 - ③ The refrigerant circuit is closed with a round, close-packed packing at the shipment to prevent gas leak between flanges. As no operation can be done under this state, be sure replace the packing with the hollow packing attached at the piping connection.
 - ④ At the mounting of the hollow packing, wipe off dust attached on the flange sheet surface and the packing. Coat refrigerating machine oil onto both surfaces of the packing.

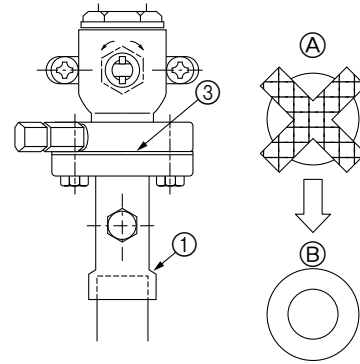

- Ⓐ Replace the close-packed packing
- Ⓑ Hollow packing

- After evacuation and refrigerant charge, ensure that the handle is fully open. If operating with the valve closed, abnormal pressure will be imparted to the high- or low-pressure side of the refrigerant circuit, giving damage to the compressor, four-way valve, etc.
- Determine the amount of additional refrigerant charge by using the formula, and charge refrigerant additionally through the service port after completing piping connection work.
- After completing work, tighten the service port and cap securely not to generate gas leak.

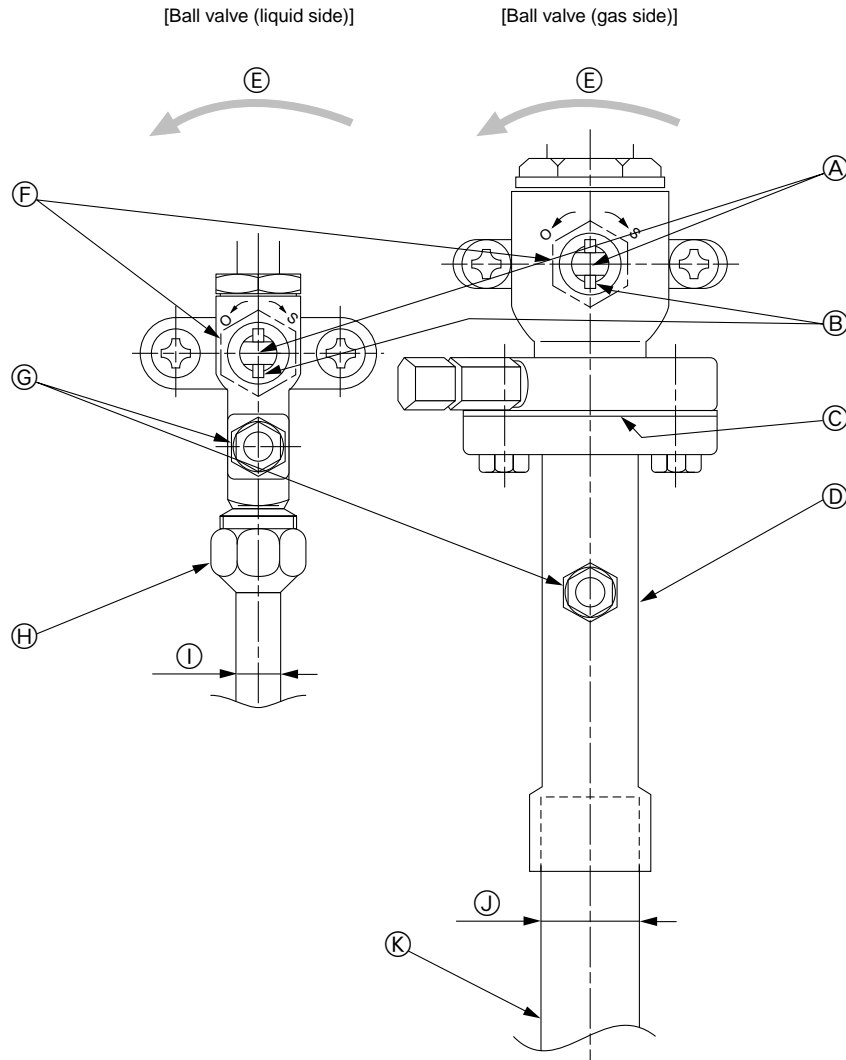

(This figure shows the valve in the fully open state.)

- Ⓐ Valve stem
[Fully closed at the factory, when connecting the piping, when evacuating, and when charging additional refrigerant. Open fully after the operations above are completed.]
- Ⓑ Stopper pin [Prevents the valve stem from turning 90° or more.]
- Ⓒ Packing (Accessory)
- Ⓓ Connecting pipe (Accessory)
[Use packing and securely install this pipe to the valve flange so that gas leakage will not occur. (Tightening torque: 43 N·m (430 kg·cm)) Coat both surfaces of the packing with refrigerator oil.]
- Ⓔ Open (Operate slowly)
- Ⓕ Cap, copper packing
[Remove the cap and operate the valve stem. Always reinstall the cap after operation is completed. (Valve stem cap tightening torque: 25 N·m (250 kg·cm) or more)]
- Ⓖ Service port
[Use this port to evacuate the refrigerant piping and add an additional charge at the site.
Open and close the port using a double-ended wrench.
Always reinstall the cap after operation is completed. (Service port cap tightening torque: 14 N·m (140 kg·cm) or more)]
- Ⓗ Flare nut
[Tightening torque: 80 N·m (800 kg·cm)
Loosen and tighten this nut using a double-ended wrench.
Coat the flare contact surface with refrigerator oil.]
- Ⓘ $\phi 15.88$
- ⓵ $\phi 31.75$ (PUHY-P400)
 $\phi 38.1$ (PUHY-P500)
- Ⓚ Field piping
[Braze to the connecting pipe. (When brazing, use unoxidized brazing.)]

Appropriate tightening torque by torque wrench

Copper pipe external dia. (mm)	Tightening torque (N·m) / (kg·cm)
$\phi 6.35$	14 to 18 / 140 to 180
$\phi 9.52$	35 to 42 / 350 to 420
$\phi 12.7$	50 to 57.5 / 500 to 575
$\phi 15.88$	75 to 80 / 750 to 800
$\phi 19.05$	100 to 140 / 1000 to 1400

Tightening angle standard

Pipe diameter (mm)	Tightening angle (°)
$\phi 6.35, \phi 9.52$	60 to 90
$\phi 12.7, \phi 15.88$	30 to 60
$\phi 19.05$	20 to 35

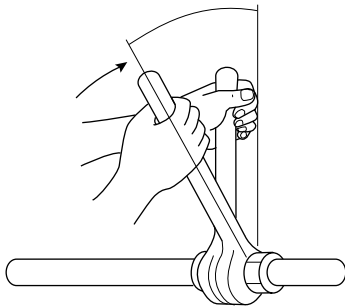

Note:

If a torque wrench is not available, use the following method as a standard.

When you tighten the flare nut with a wrench, you will reach a point where the tightening torque will abruptly increase. Turn the flare nut beyond this point by the angle shown in the table above.

⚠ Caution:

- **Always remove the connecting pipe from the ball valve and braze it outside the unit.**
 - Brazing the connecting pipe while it is installed will heat the ball valve and cause trouble or gas leakage. The piping, etc. inside the unit may also be burned.
- **Use ester oil, ether oil or alkylbenzene (small amount) as the refrigerator oil to coat flares and flange connections.**
 - The refrigerator oil will degrade if it is mixed with a large amount of mineral oil.

10.4. How to install branch pipe

For detail, please observe the instruction manual attached to the optional refrigerant branch kit.

■ Joint

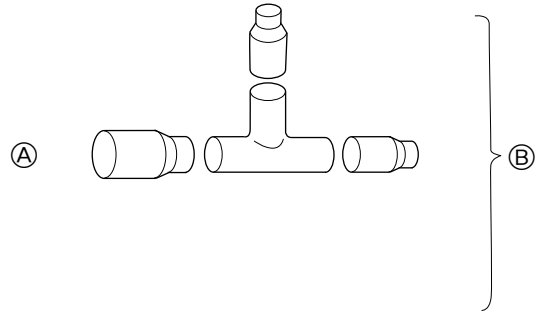

- Ⓐ To Outdoor Unit
- Ⓑ To Branch Piping or Indoor Unit

- Apart from the CMY-Y202-F gas side, there are no restrictions on the posture for attaching joints.
- Ensure that the branch pipes for the CMY-Y202-F gas side are attached horizontally or facing upwards. (See the diagram below.)

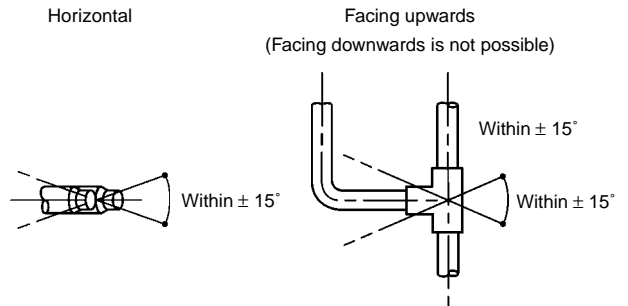

- There is no limitation on the joint mounting configuration.
- If the diameter of the refrigerant piping selected by the procedures described on pages 13 to 14 is different from the size of the joint, match the sizes using a deformed joint. The deformed joint is included with the kit.

■ Header

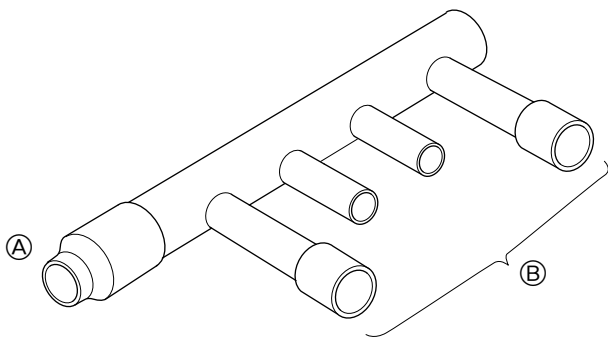

- Ⓐ To outdoor unit
- Ⓑ To indoor unit

- No restriction is applied to the mounting posture of the header.
- If the diameter of the refrigerant piping selected using the procedures described on pages 14 and the size of the joint is different, match the sizes using a deformed joint. The deformed joint is included with the kit.

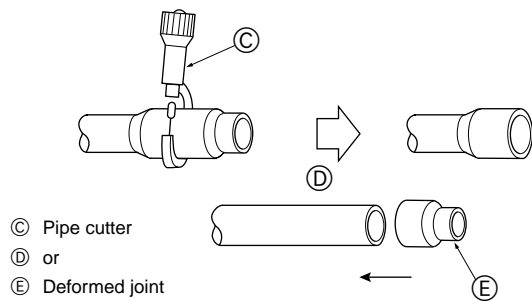

- Ⓒ Pipe cutter
- Ⓓ or
- Ⓔ Deformed joint

- When the number of pipes to be connected is smaller than the number of header branches, install a cap to the unconnected branches. The cap is included with the kit.

10.5. Airtight test and evacuation, refrigerant charging

① Airtight test

Perform with the stop valve of the outdoor unit closed, and pressurize the connection piping and the indoor unit from the service port provided on the stop valve of the outdoor unit. (Always pressurize from both the liquid pipe and the gas pipe service ports.)

- Ⓐ Nitrogen gas
- Ⓑ To indoor unit
- Ⓒ System analyzer
- Ⓓ Lo Knob
- Ⓔ Hi Knob
- Ⓕ Ball valve
- Ⓖ Liquid pipe
- Ⓗ Gas pipe
- Ⓘ Outdoor unit
- ⓵ Service port

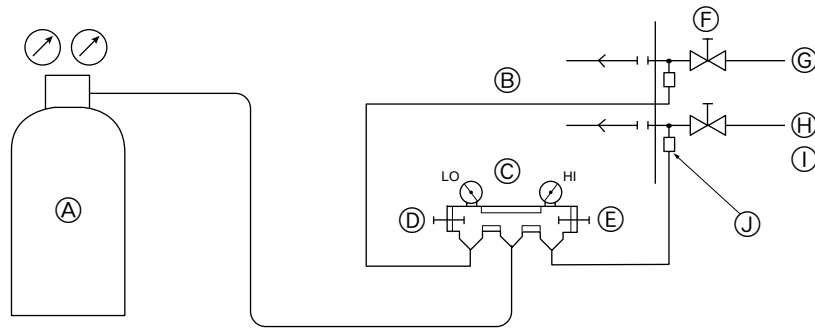

The method of conducting the airtight test is basically the same as for older models. However, since the restrictions have a large effect on deterioration of the refrigerator oil, always observe them. Also, with nonazeotropic refrigerant (R407C, etc.), gas leakage causes the composition to change and affects performance. Therefore, since the entire amount must be replaced if gas leakage occurs, perform the airtightness test cautiously.

Airtight test procedure	Restriction
<p>1. Nitrogen gas pressurization</p> <p>(1) After pressurizing to the design pressure (2.98 MPa) using nitrogen gas, let stand for about one day. If the pressure does not drop, airtightness is good. However, if the pressure drops, since the leaking point is unknown, the following bubble test may also be performed.</p> <p>(2) After the pressurization described above, spray the flare connection parts, brazed parts, flanges, and other parts that may leak with a bubbling agent (Kyuboflex, etc.) and visually check for bubbles.</p> <p>(3) After the airtight test, wipe off the bubbling agent.</p>	<ul style="list-style-type: none"> • If a flammable gas or air (oxygen) is used as the pressurization gas, it may catch fire or explode.
<p>2. Pressurization using refrigerant gas and nitrogen gas</p> <p>(1) After sealing with liquid R407C from a cylinder and pressurizing to a gas pressure of approximately 0.2 MPa, pressurize to the design pressure (2.98 MPa) using nitrogen gas. However, do not pressurize at one time. Stop during pressurization and check that the pressure does not drop.</p> <p>(2) Check for gas leaks by checking the flare connection parts, brazed parts, flanges, and other parts which may leak using an R407C compatible electric leak detector.</p> <p>(3) This test may be used together with the bubble type gas leak test.</p>	<ul style="list-style-type: none"> • Do not use a refrigerant other than that indicated on the unit. • Sealing with gas from a cylinder will cause the composition of the refrigerant in the cylinder to change. • Use a pressure gauge, charge box, and other parts especially for R407C. • An electric leak detector for R22 cannot detect leaks. • Do not use a haloid torch. (Leaks cannot be detected.)

⚠ Caution:

Do not use a refrigerant other than R407C.

- If a refrigerant (R22, etc.) other than R407C is used, the chlorine in the refrigerant will cause the refrigerator oil to deteriorate.

② **Evacuation**

As shown in the figure below, evacuate with the stop valve of the outdoor unit closed and evacuate both the connection piping and the indoor unit from the service port on the stop valve of the outdoor unit using a vacuum pump. (Always evacuate from the service port of both the liquid pipe and the gas pipe.) After the vacuum reaches 650 Pa, continue evacuation for at least one hour or more. Then, stop the vacuum pump and let stand for one day and check if the vacuum does not rise. (If the vacuum rises, since water may be mixed in, pressurize up to 0.05 MPa using dry nitrogen gas and evacuate again.)

Evacuate from the service port of the ball valve with a vacuum pump.

Finally, seal with liquid refrigerant from the liquid pipe. Moreover, during operation, adjust the refrigerant amount from the gas pipe so that the refrigerant is always an appropriate amount.

* Never perform air purging using refrigerant.

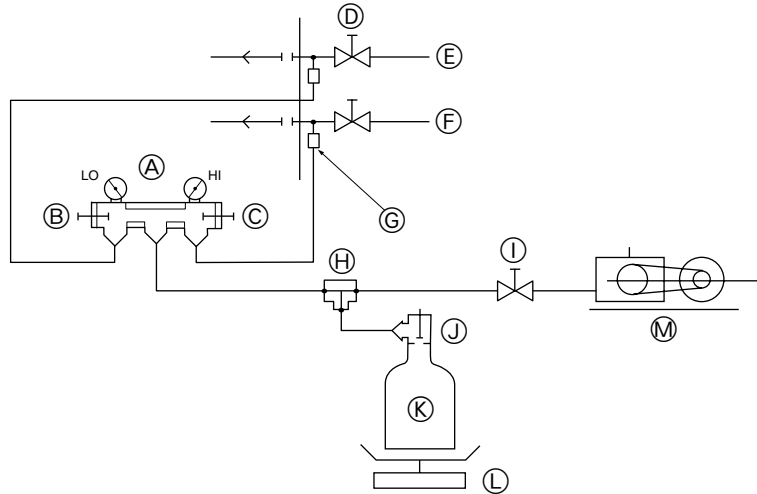

- Ⓐ System analyzer
- Ⓑ Lo Knob
- Ⓒ Hi Knob
- Ⓓ Ball valve
- Ⓔ Liquid pipe
- Ⓕ Gas pipe
- Ⓖ Service port
- Ⓗ Three-way joint
- Ⓘ Valve
- Ⓙ Valve
- Ⓚ R407C cylinder

- Ⓛ Scale
Use a gravimeter. (One that can measure down to 0.1 kg.)
- Ⓜ Vacuum pump
Use a vacuum pump with a reverse flow check valve.
(Recommended vacuum gauge: ROBINAIR 14830A Thermistor Vacuum Gauge)
Also use a vacuum gauge that reaches 65 Pa or greater after operating for five minutes.

③ Refrigerant Charging

Since the refrigerant used with the unit is nonazeotropic, it must be charged in the liquid state. Consequently, when charging the unit with refrigerant from a cylinder, if the cylinder does not have a syphon pipe, charge the liquid refrigerant by turning the cylinder upside-down as shown below. If the cylinder has a syphon valve like that shown in the figure at the right, the liquid refrigerant can be charged with the cylinder standing upright. Therefore, give careful attention to the cylinder specifications. If the unit should be charged with gas refrigerant, replace all the refrigerant with new refrigerant. Do not use the refrigerant remaining in the cylinder.

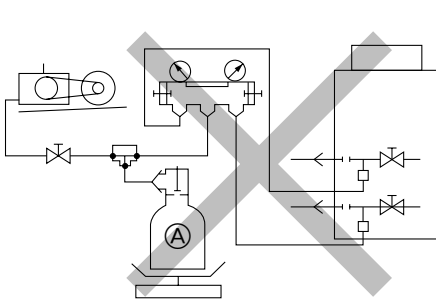

[When cylinder does not have a syphon pipe]

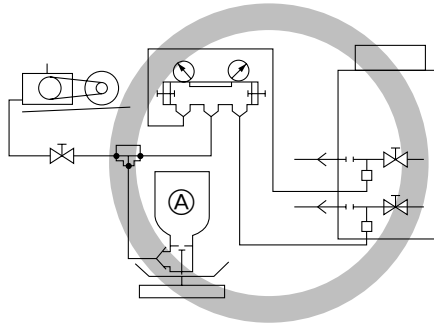

[When cylinder has a syphon pipe
(Refrigerant can be charged with the
cylinder standing upright.)]

- Ⓐ R407C cylinder
- Ⓑ Syphon pipe
- Ⓒ Liquid refrigerant

Note:

Always add an appropriate amount of refrigerant. (For the refrigerant additional charge, see pages 13 to 14.) Also always seal the system with liquid refrigerant. Too much or too little refrigerant will cause trouble.

Use a gauge manifold, charging hose, and other parts for the refrigerant indicated on the unit.

Note that it is not possible to determine if a correct amount is being used with the accumulator level (AL).

⚠ Warning:

When installing or moving the unit, do not charge it with refrigerant other than the refrigerant (R407C) specified on the unit.

- Mixing of different refrigerant, air, etc. may cause the refrigerant cycle to malfunction and result in severe damage.

⚠ Caution:

• **Use a vacuum pump with a reverse flow check valve.**

- If the vacuum pump does not have a reverse flow check valve, the vacuum pump oil may flow back into the refrigerant cycle and cause deterioration of the refrigerator oil and other trouble.

• **Do not use a charging cylinder.**

- Using a charging cylinder may cause the refrigerant to deteriorate.

• **Do not use the tools shown below used with conventional refrigerant.**

(Gauge manifold, charge hose, gas leak detector, check valve, refrigerant charge base, vacuum gauge, refrigerant recovery equipment)

- Mixing of conventional refrigerant and refrigerator oil may cause the refrigerator oil to deteriorate.

- Mixing of water will cause the refrigerator oil to deteriorate.

- R407C refrigerant does not contain any chlorine. Therefore, gas leak detectors for conventional refrigerants will not react to it.

• **Manage the tools more carefully than normal.**

- If dust, dirt, or water gets in the refrigerant cycle, the refrigerator oil will deteriorate.

10.6. Thermal insulation of refrigerant piping

Be sure to give insulation work to refrigerant piping by covering liquid pipe and gas pipe separately with enough thickness heat-resistant polyethylene, so that no gap is observed in the joint between indoor unit and insulating material, and insulating materials themselves. When insulation work is insufficient, there is a possibility of condensation drip, etc. Pay special attention to insulation work to ceiling plenum.

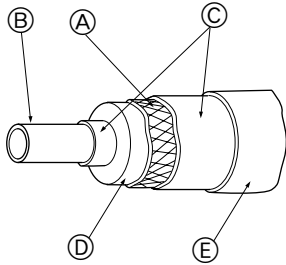

- Ⓐ Steel wire
- Ⓑ Piping
- Ⓒ Asphaltic oily mastic or asphalt
- Ⓓ Heat insulation material A
- Ⓔ Outer covering B

Heat insulation material A	Glass fiber + Steel wire	
	Adhesive + Heat - resistant polyethylene foam + Adhesive tape	
Outer covering B	Indoor	Vinyl tape
	Floor exposed	Water-proof hemp cloth + Bronze asphalt
	Outdoor	Water-proof hemp cloth + Zinc plate + Oily paint

Note:

When using polyethylene cover as covering material, asphalt roofing shall not be required.

<p>Bad example</p>	<ul style="list-style-type: none"> Do not insulate gas or low pressure pipe and liquid or high pressure pipe together. <ul style="list-style-type: none"> Ⓐ Liquid pipe Ⓑ Gas pipe Ⓒ Electric wire Ⓓ Finishing tape Ⓔ Insulating material 	<ul style="list-style-type: none"> Be sure to fully insulate connecting portion. <p>Ⓐ These parts are not insulated.</p>
<p>Good example</p>	<ul style="list-style-type: none"> Ⓐ Liquid pipe Ⓑ Gas pipe Ⓓ Finishing tape Ⓔ Insulating material 	

Note:

No heat insulation must be provided for electric wires.

Penetrations

Inner wall (concealed)

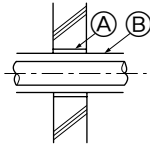

Floor (fireproofing)

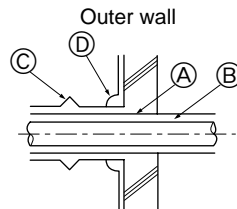
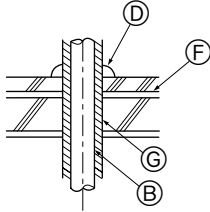

Roof pipe shaft

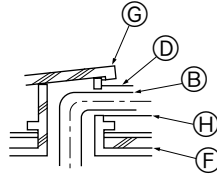

Outer wall (exposed)

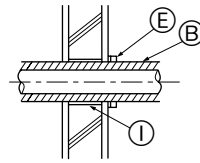

Penetrating portion on fire limit and boundary wall

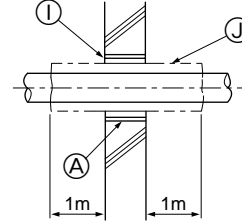

- (A) Sleeve
- (B) Heat insulating material
- (C) Lagging
- (D) Caulking material
- (E) Band
- (F) Waterproofing layer
- (G) Sleeve with edge

- (H) Lagging material
- (I) Mortar or other incombustible caulking
- (J) Incombustible heat insulation material

When filling a gap with mortar, cover the penetration part with steel plate so that the insulation material will not be caved in. For this part, use incombustible materials for both insulation and covering. (Vinyl covering should not be used.)

Branch piping section

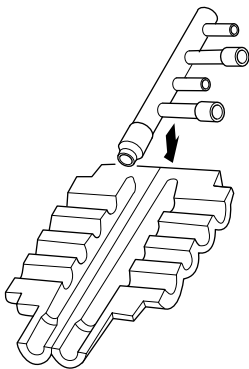

Insulate the header using the insulation material attached to the branch pipe kit as shown in the figure.

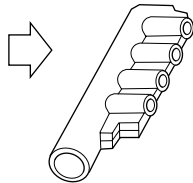

11. Electrical work

11.1. Caution

① Follow ordinance of your governmental organization for technical standard related to electrical equipment, wiring regulations and guidance of each electric power company.

⚠ Warning:

Be sure to have authorized electric engineers do electric work using special circuits in accordance with regulations and this installation manual. If power supply circuit has a lack of capacity or electric work deficiency, it may cause an electric shock or fire.

② Install the outdoor unit transmission line away from the power source wiring so that it is not affected by electric noise from the power source. (Do not run it through the same conduit.)

③ Be sure to provide designated grounding work to outdoor unit.

⚠ Caution:

Be sure to put outdoor unit to earth. Do not connect earth line to any gas pipe, water pipe, lightning rod or telephone earth line. If earth is incomplete, it may cause an electric shock.

④ Give some allowance to wiring for electrical part box of indoor and outdoor units, because the box is sometimes removed at the time of service work.

⑤ Never connect the main power source to terminal block of transmission line. If connected, electrical parts will be burnt out (○ mark in the figure below).

⑥ Use 2-core shield cable for transmission line. If transmission lines of different systems are wired with the same multiplecore cable, the resultant poor transmitting and receiving will cause erroneous operations (X mark in the figure below).

⑦ Only the transmission line specified should be connected to the terminal block for outdoor unit transmission.
(Transmission line to be connected with indoor unit : Terminal block TB3 for transmission line, Other : Terminal block TB7 for centralized control)
Erroneous connection does not allow the system to operate.

⑧ In case to connect with the upper class controller or to conduct group operation in different refrigerant systems, the control line for transmission is required between the outdoor units each other.
Connect this control line between the terminal blocks for centralized control. (2-wire line with no polarity)
When conducting group operation in different refrigerant systems without connecting to the upper class controller, replace the insertion of the short circuit connector from CN41 of one outdoor unit to CN40.

⑨ Group is set by operating the remote controller.

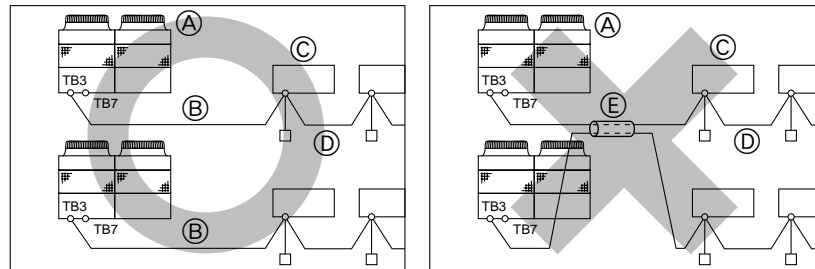

TB3: Transmission line terminal board, TB7: Central control line terminal board

- Ⓐ Outdoor unit
- Ⓑ 2-core cable
- Ⓒ Indoor unit
- Ⓓ Remote controller
- Ⓔ Multi-core cable

11.2. Control box and connecting position of wiring

① Outdoor unit

1. Remove the total of six screws at the top and bottom, and remove the service panel by pulling it forward. (See the figure below.)

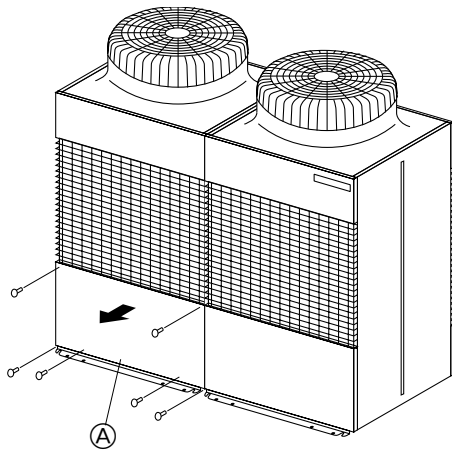

(A) Service panel

2. Remove the two screws on the left and right-hand of the base of the control box and pull the overall cover downwards to detach it. (A diagram with the control box cover removed is shown below.)

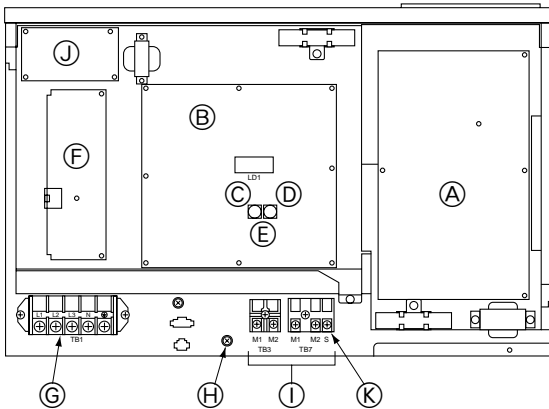

- (A) INV board
- (B) MAIN board
- (C) Ten position
- (D) One position
- (E) Address switch
- (F) FANCON board
- (G) Power source
- (H) Shield screw
- (I) Transmission line
- (J) RELAY board
- (K) Shield terminal (S)

3. Connect indoor and outdoor units through the terminal block for transmission lines (TB3). Outdoor units and connections to central control systems go through the terminal block for centralized control (TB7). When making an indoor/outdoor connection with shielded wiring, connect the shield ground to the shield screw. When making a central control system connection with shielded wiring, use the terminal block for centralized control (TB7). When the CN41 power supply connector of an outdoor unit has been replaced with a CN40, the shield terminal (S) for centralized control (TB7) should also be connected to the shield screw.

② How to use the conduit mounting plate

- (1) Conduit mounting plates (ø46, ø53, ø62) are being provided. Select conduit mounting plate based on the outside diameter of conduit to be used and mount it as shown in the figure.
- (2) Fix power source wiring to control box by using buffer bushing for tensile force (PG connection or the like).

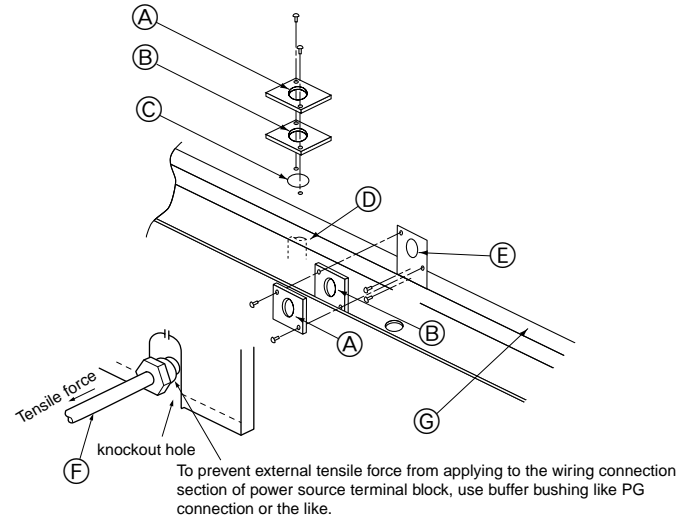

- (A) ø46 mounting hole
- (B) ø53 mounting hole
- (C) ø62 knockout hole
- (D) For the connection of conduit at bottom
- (E) ø62 mounting hole
- (F) For the connection of conduit at front
- (G) The front of outdoor unit

③ How to use the wire mounting plate

- (1) When the power source and transmission lines are wired through the knock-out hole of the left wiring, it is necessary to attach the mounting plate onto the base of the front of the control box with two screws.

In this case, please use the top clamp to fasten the transmission line and the lower installation hole to fasten the power supply line. If it does not match with the outer diameter of the power line conduit, mount the power line conduit mounting plate (ø46) as shown in the figure below. Also, please fasten it so that no tension is brought to bear on the power line, as shown above.

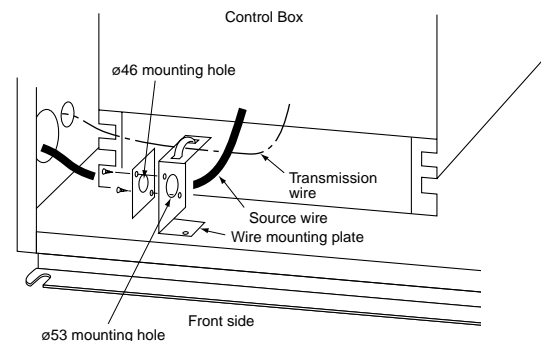

④ Transmission booster (optional)

(For details, see item 11.3. "Wiring transmission cables")

Connect 220/230/240 VAC to L/N of power terminal block (TB1).

Connect the ground to the ⊥ terminal of power terminal block (TB1).

Connect the outdoor unit side transmission cables to A/B of transmission cables terminal block 1 (TB2).

Connect the outdoor unit side shield to S of transmission cables terminal block 1 (TB2).

Connect additional indoor unit side transmission cables to A/B of transmission cables terminal block 2 (TB3).

Connect additional indoor unit side shield to S of transmission cables terminal block 2 (TB3).

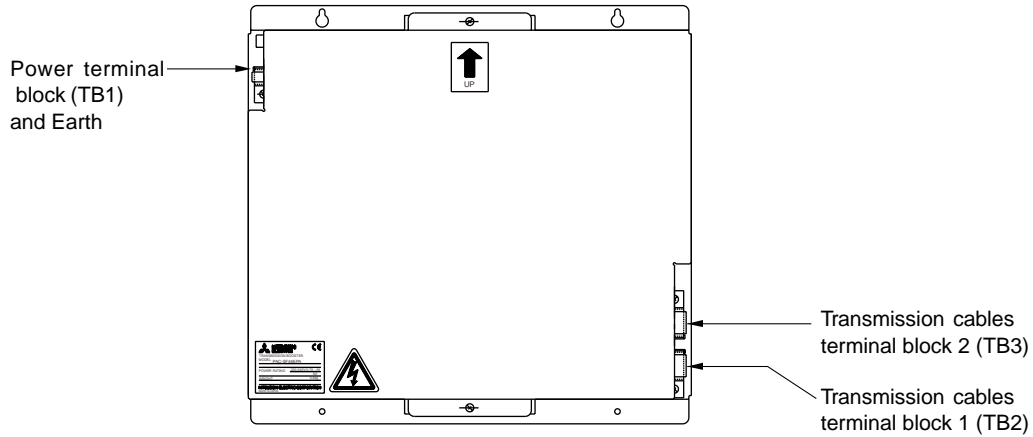

11.3. Wiring transmission cables

Wiring method, address setting method and permissible wiring length differ according to and whether or not you are using transmission booster. Check permissible wiring length before wiring.

A may be required depending on the number of indoor units.

Item ④ "Wiring examples" gives typical wiring examples (A – C).

- A. System using remote controller (1 outdoor unit)
- B. System using remote controller (system operated as a group among multiple refrigerant systems)
- C. System using power supply extension unit for transmission booster (combination of systems a – b)

① Connecting a transmission booster

A transmission booster (RP) is required when the number of connected indoor unit models in a cooling system exceeds the number of models specified in the chart below.

* The maximum number of units that can be controlled is determined by the indoor unit model, the type of remote controller and their capabilities.

(*1) Capability of the connected indoor units	Remote controller type Number of connected indoor units that can be connected without a RP.	Remote controller PAR-F 25MA	
		Prior to Ver. E	After Ver. F
	200 or lower	16 (32)	20 (40)
	200 or higher	16 (32)	16 (32)

The number of indoor units and the total number of remote controllers is displayed within the parenthesis ().

*1 If even one unit that is higher than 200 exists in the cooling system, the maximum capacity will be "200 or higher".

② Name, code and possible unit connections

Name	Code	Possible unit connections	
Outdoor unit	Outdoor unit controller	OC	–
Indoor unit	Indoor unit controller	IC	2 to 32 units per 1 OC (*1)
Remote controller	Remote controller (*1)	RC	2 units maximum per group
Other	Transmission booster unit	RP	0 to 1 unit per 1 OC (*1)

*1 A transmission booster (RP) may be required depending on the number of connected indoor unit controllers.

③ Types of control cables

(1) Wiring transmission cables

- Types of transmission cables
Shielding wire CVVS or CPEVS
- Cable diameter
More than 1.25 mm²
- Maximum wiring length within 200 m

(2) Remote control cables

Kind of remote control cable	2-core cable (unshielded)
Cable diameter	0.5 to 0.75 mm ²
Remarks	When 10 m is exceeded, use cable with the same specifications as (1) Transmission line wiring.

④ Wiring examples

Typical wiring examples are shown on pages 26 to 30 (Wiring examples A – C).

A. Example of a single-outdoor-unit system (Shielding wires and address setting are necessary)

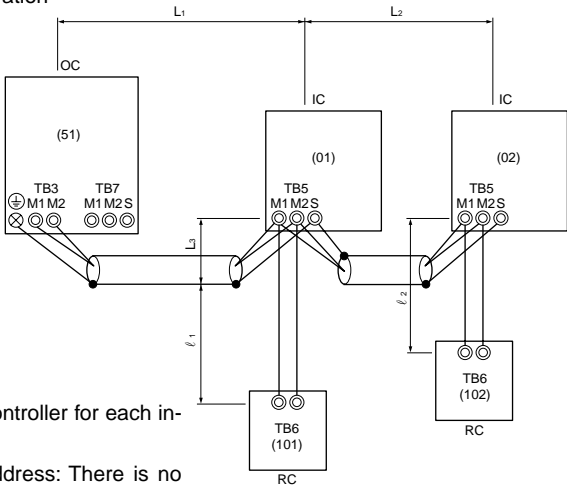
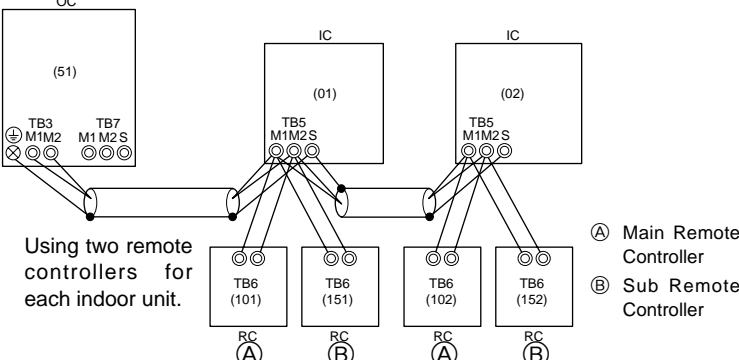
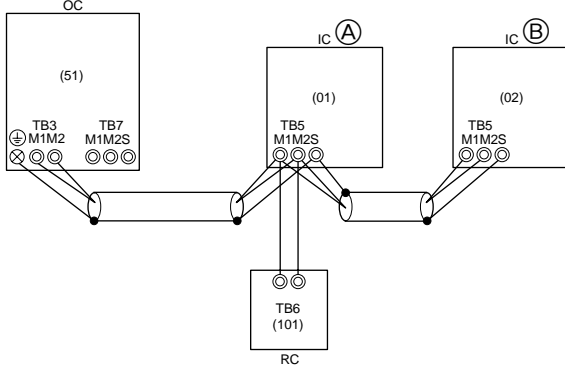
Example of Wiring Control Cables	Wiring Method and Address Setting																				
<p>1. Standard Operation</p>  <ul style="list-style-type: none"> One remote controller for each indoor unit. Inside () Address: There is no need for setting the 100 position on the remote controller. 	<p>a. Use feed wiring to connect terminals M1 and M2 on transmission cable block (TB3) for the outdoor unit (OC) to terminals M1 and M2 on the transmission cable block (TB5) of each indoor unit (IC). Use non-polarized two wire. To ground the shielded wire, use cross-over wiring from the ground terminal ⊕ on the outdoor unit and terminal S on the indoor unit (TB5).</p> <p>b. Connect terminals M1 and M2 on the transmission cable block (TB5) for each indoor unit with the terminal block (TB6) for the remote controller (RC).</p> <p>c. Set the address setting switch as shown below.</p> <p>* To set the outdoor unit address to 100, the outdoor address setting switch must be set to 50.</p> <table border="1" data-bbox="879 539 1497 745"> <thead> <tr> <th>Unit</th> <th>Range</th> <th>Setting Method</th> </tr> </thead> <tbody> <tr> <td>Indoor Unit</td> <td>01 to 50</td> <td>—</td> </tr> <tr> <td>Outdoor Unit</td> <td>51 to 100</td> <td>Use the most recent address of all the indoor units plus 50</td> </tr> <tr> <td>Remote Controller</td> <td>101 to 150</td> <td>Indoor unit address plus 100</td> </tr> </tbody> </table>			Unit	Range	Setting Method	Indoor Unit	01 to 50	—	Outdoor Unit	51 to 100	Use the most recent address of all the indoor units plus 50	Remote Controller	101 to 150	Indoor unit address plus 100						
Unit	Range	Setting Method																			
Indoor Unit	01 to 50	—																			
Outdoor Unit	51 to 100	Use the most recent address of all the indoor units plus 50																			
Remote Controller	101 to 150	Indoor unit address plus 100																			
<p>2. Operation Using Two Remote controllers</p>  <ul style="list-style-type: none"> Using two remote controllers for each indoor unit. 	<p>a. Same as above</p> <p>b. Same as above</p> <p>c. Set the address switch as shown below.</p> <p>* To set the outdoor unit address to 100, the outdoor address setting switch must be set to 50.</p> <table border="1" data-bbox="879 902 1497 1171"> <thead> <tr> <th>Unit</th> <th>Range</th> <th>Setting Method</th> </tr> </thead> <tbody> <tr> <td>Indoor Unit</td> <td>01 to 50</td> <td>—</td> </tr> <tr> <td>Outdoor Unit</td> <td>51 to 100</td> <td>Use the most recent address of all the indoor units plus 50</td> </tr> <tr> <td>Main Remote Controller</td> <td>101 to 150</td> <td>Indoor unit address plus 100</td> </tr> <tr> <td>Sub Remote Controller</td> <td>151 to 200</td> <td>Indoor unit address plus 150</td> </tr> </tbody> </table>			Unit	Range	Setting Method	Indoor Unit	01 to 50	—	Outdoor Unit	51 to 100	Use the most recent address of all the indoor units plus 50	Main Remote Controller	101 to 150	Indoor unit address plus 100	Sub Remote Controller	151 to 200	Indoor unit address plus 150			
Unit	Range	Setting Method																			
Indoor Unit	01 to 50	—																			
Outdoor Unit	51 to 100	Use the most recent address of all the indoor units plus 50																			
Main Remote Controller	101 to 150	Indoor unit address plus 100																			
Sub Remote Controller	151 to 200	Indoor unit address plus 150																			
<p>3. Group Operation</p>  <ul style="list-style-type: none"> Operating multiple indoor units using one remote controller. 	<p>a. Same as above</p> <p>b. Connect terminals M1 and M2 on transmission cable terminal block (TB5) of the IC main unit with the most recent address within the same indoor unit (IC) group to terminal block (TB6) on the remote controller.</p> <p>c. Set the address setting switch as shown below.</p> <p>* To set the outdoor unit address to 100, the outdoor address setting switch must be set to 50.</p> <table border="1" data-bbox="879 1417 1497 1933"> <thead> <tr> <th>Unit</th> <th>Range</th> <th>Setting Method</th> </tr> </thead> <tbody> <tr> <td>IC (Main)</td> <td>01 to 50</td> <td>Use the most recent address within the same group of indoor units</td> </tr> <tr> <td>IC (Sub)</td> <td>01 to 50</td> <td>Use an address, other than that of the IC (Main) from among the units within the same group of indoor units. This must be in sequence with the IC (Main)</td> </tr> <tr> <td>Outdoor Unit</td> <td>51 to 100</td> <td>Use the most recent address of all the indoor units plus 50</td> </tr> <tr> <td>Main Remote Controller</td> <td>101 to 150</td> <td>Set at an IC (Main) address within the same group plus 100</td> </tr> <tr> <td>Sub Remote Controller</td> <td>151 to 200</td> <td>Set at an IC (Main) address within the same group plus 150</td> </tr> </tbody> </table> <p>d. Use the indoor unit (IC) within the group with the most functions as the IC (Main) unit.</p>			Unit	Range	Setting Method	IC (Main)	01 to 50	Use the most recent address within the same group of indoor units	IC (Sub)	01 to 50	Use an address, other than that of the IC (Main) from among the units within the same group of indoor units. This must be in sequence with the IC (Main)	Outdoor Unit	51 to 100	Use the most recent address of all the indoor units plus 50	Main Remote Controller	101 to 150	Set at an IC (Main) address within the same group plus 100	Sub Remote Controller	151 to 200	Set at an IC (Main) address within the same group plus 150
Unit	Range	Setting Method																			
IC (Main)	01 to 50	Use the most recent address within the same group of indoor units																			
IC (Sub)	01 to 50	Use an address, other than that of the IC (Main) from among the units within the same group of indoor units. This must be in sequence with the IC (Main)																			
Outdoor Unit	51 to 100	Use the most recent address of all the indoor units plus 50																			
Main Remote Controller	101 to 150	Set at an IC (Main) address within the same group plus 100																			
Sub Remote Controller	151 to 200	Set at an IC (Main) address within the same group plus 150																			
<p>Combinations of 1 through 3 above are possible.</p>																					

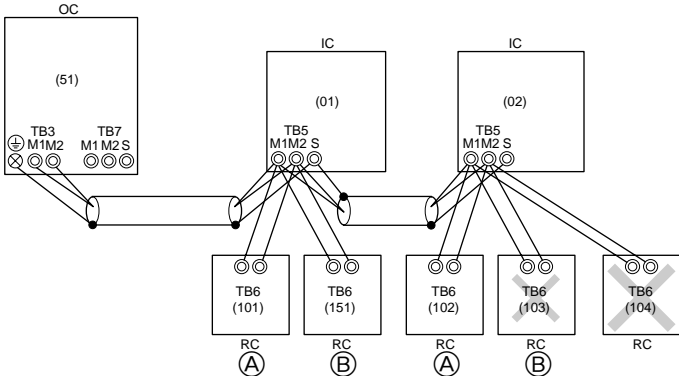
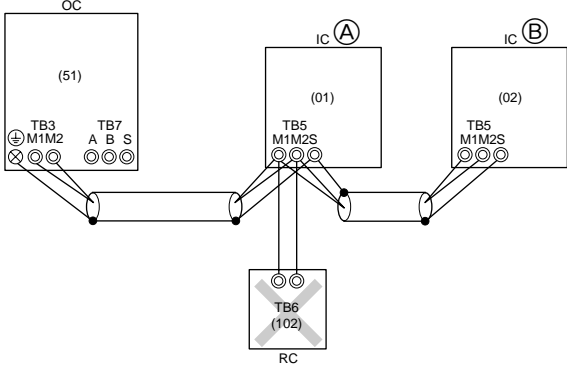
Permissible Lengths	Prohibited Items
<p>Longest Transmission Cable Length (1.25 mm²) $L_1 + L_2, L_2 + L_3, L_3 + L_1 \leq 200$ m Remote Controller Cable Length 1 If 0.5 to 0.75 mm² $l_1, l_2 \leq 10$ m 2 If the length exceeds 10 m, the exceeding section should be 1.25 mm² and that section should be a value within the total extension length of the transmission cable and maximum transmission cable length (L₃).</p>	<p style="text-align: center;">_____</p>
<p>Same as above</p>	 <ul style="list-style-type: none"> • Use the indoor unit (IC) address plus 150 as the sub remote controller address. In this case, it is 152. • Three or more remote controllers (RC) cannot be connected to one indoor unit. <p style="text-align: right;">(A) Main (B) Sub</p>
<p>Same as above</p>	 <ul style="list-style-type: none"> • The remote controller address is the indoor unit main address plus 100. In this case, it is 101. <p style="text-align: right;">(A) Main (B) Sub</p>

Note:
 1. If there is one or more 200 or higher indoor units within the same cooling system, and the number of indoor units exceeds 16 units, a transmission booster is necessary (when a "PAR-F25MA Ver. F" or subsequent version of remote control is used).
 2. If there is not even one 200 or higher indoor unit within the same cooling system, and the number of indoor units exceeds 20 units, a transmission booster is necessary (when a "PAR-F25MA Ver. F" or subsequent version of remote control is used).
 * For details, see wire connection example C.

B. Example of a group operation system with multiple outdoor units (Shielding wires and address setting are necessary)

Example of transmission line wiring

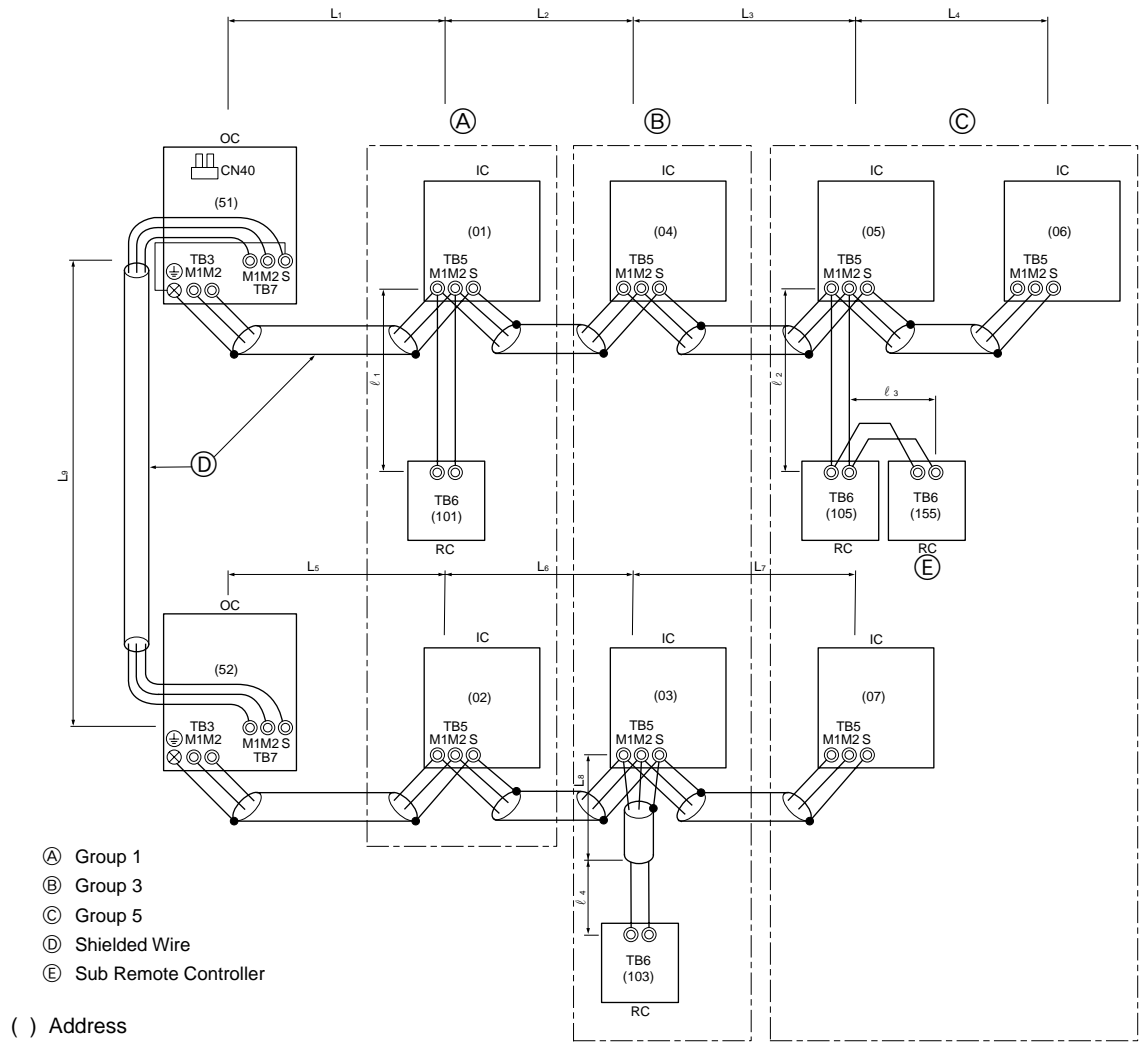

Wiring method, address setting method

- Always use shielded wire when making connections between the outdoor unit (OC) and the indoor unit (IC), as well for all OC-OC, and IC-IC wiring intervals.
- Use feed wiring to connect terminals M1 and M2 and the ground terminal on the transmission cable terminal block (TB3) of each outdoor unit (OC) to terminals M1, M2 and terminal S on the transmission cable block of the indoor unit (IC).
- Connect terminals M1 and M2 on the transmission cable terminal block of the indoor unit (IC) that has the most recent address within the same group to the terminal block (TB6) on the remote controller (RC).
- Connect together terminals M1, M2 and terminal S on the terminal block for central control (TB7) for the outdoor unit (OC).
- On one outdoor unit only, change the jumper connector on the control panel from CN41 to CN40.
- Connect the terminal S on the terminal block for central control (TB7) for the outdoor unit (OC) for the unit into which the jumper connector was inserted into CN40 in Step above to the ground terminal (⊕) in the electrical component box.
- Set the address setting switch as follows.
 - * To set the outdoor unit address to 100, the outdoor address setting switch must be set to 50.

Unit	Range	Setting Method
IC (Main)	01 to 50	Use the most recent address within the same group of indoor units
IC (Sub)	01 to 50	Use an address, other than that of the IC (Main) from among the units within the same group of indoor units This must be in sequence with the IC (Main)
Outdoor Unit	51 to 100	Use the most recent address of all the indoor units plus 50
Main Remote Controller	101 to 150	Set at an IC (Main) address within the same group plus 100
Sub Remote Controller	151 to 200	Set at an IC (Main) address within the same group plus 150

- The group setting operations among the multiple indoor units is done by the remote controller (RC) after the electrical power has been turned on.

Permissible Lengths

- Max length via outdoor units: $L_1+L_2+L_3+L_4+L_5+L_6+L_7+L_9$,
 $L_1+L_2+L_3+L_4+L_5+L_6+L_8+L_9 \leq 500 \text{ m (1.25 mm}^2\text{)}$
- Max transmission cable length: $L_1+L_2+L_3+L_4$, $L_5+L_6+L_7$, $L_5+L_6+L_8$, $L_7+L_8 \leq 200 \text{ m (1.25 mm}^2\text{)}$
- Remote controller wire length: $l_1, l_2, l_3, l_4 \leq 10 \text{ m (0.5 to 0.75 mm}^2\text{)}$
 If the length exceeds 10 m, use a 1.25 mm² shielded wire. The length of this section (L_s) should be included in the calculation of the maximum length and overall length.

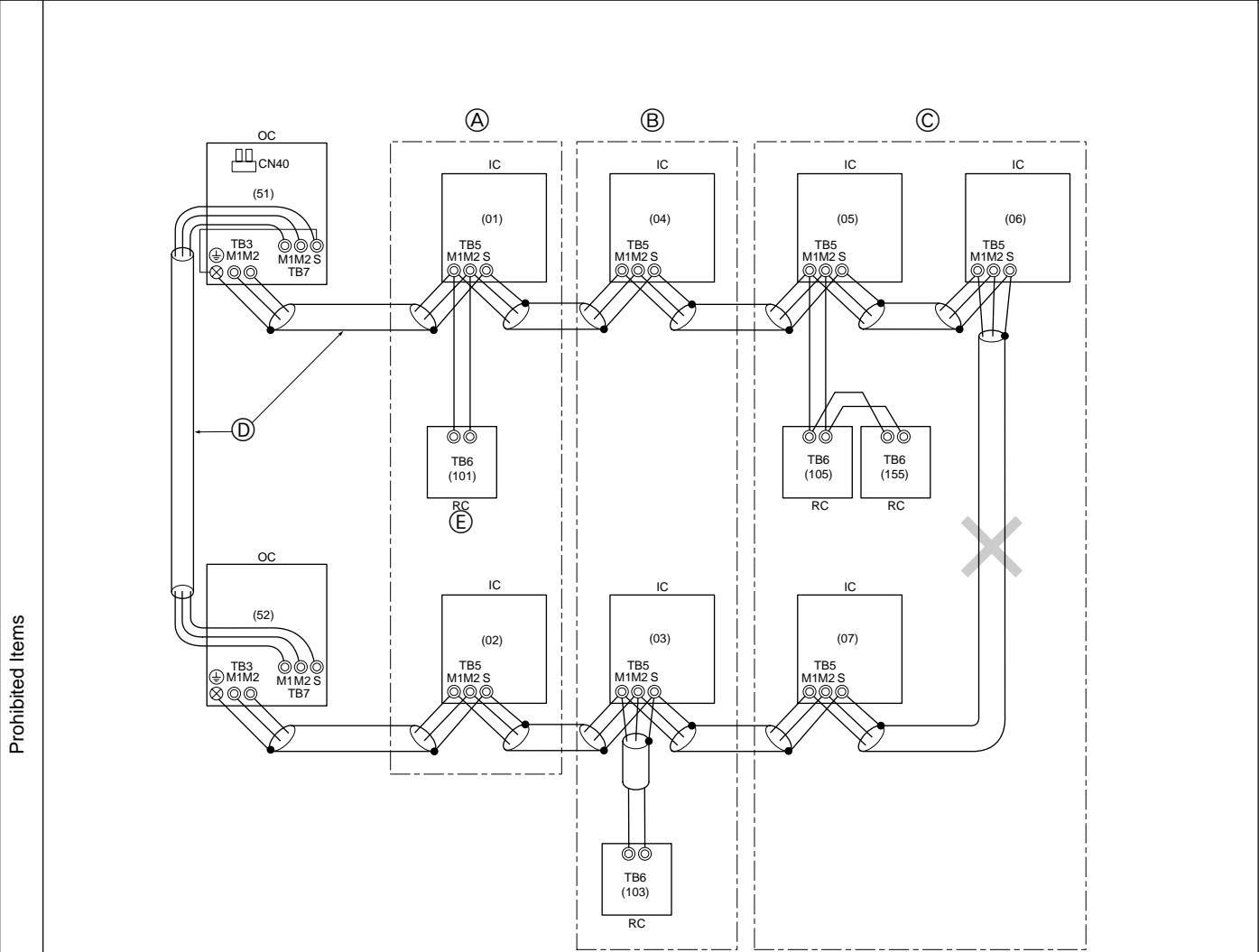

- Ⓐ Group 1
- Ⓑ Group 3
- Ⓒ Group 5
- Ⓓ Shielded Wire
- Ⓔ Remote Controller

- The terminal S on the terminal block (TB7) for the central control panel should be connected to the ground terminal (⊕) of the electric components box of the only outdoor unit installed with the CN40 into which the jumper connector was inserted.
- Never connect together the terminal blocks (TB5) for transmission wires for indoor units (IC) that have been connected to different outdoor units (OC).
- Set all addresses to ensure that they are not overlapped.

Note:

1. If there is one or more 200 or higher indoor units within the same cooling system, and the number of indoor units exceeds 16 units, a transmission booster is necessary (when a "PAR-F25MA Ver. F" or subsequent version of remote control is used).
2. If there is not even one 200 or higher indoor unit within the same cooling system, and the number of indoor units exceeds 20 units, a transmission booster is necessary (when a "PAR-F25MA Ver. F" or subsequent version of remote control is used).

* For details, see wire connection example C.

C. Example of a system using the transmission booster (Combination of systems A and B)

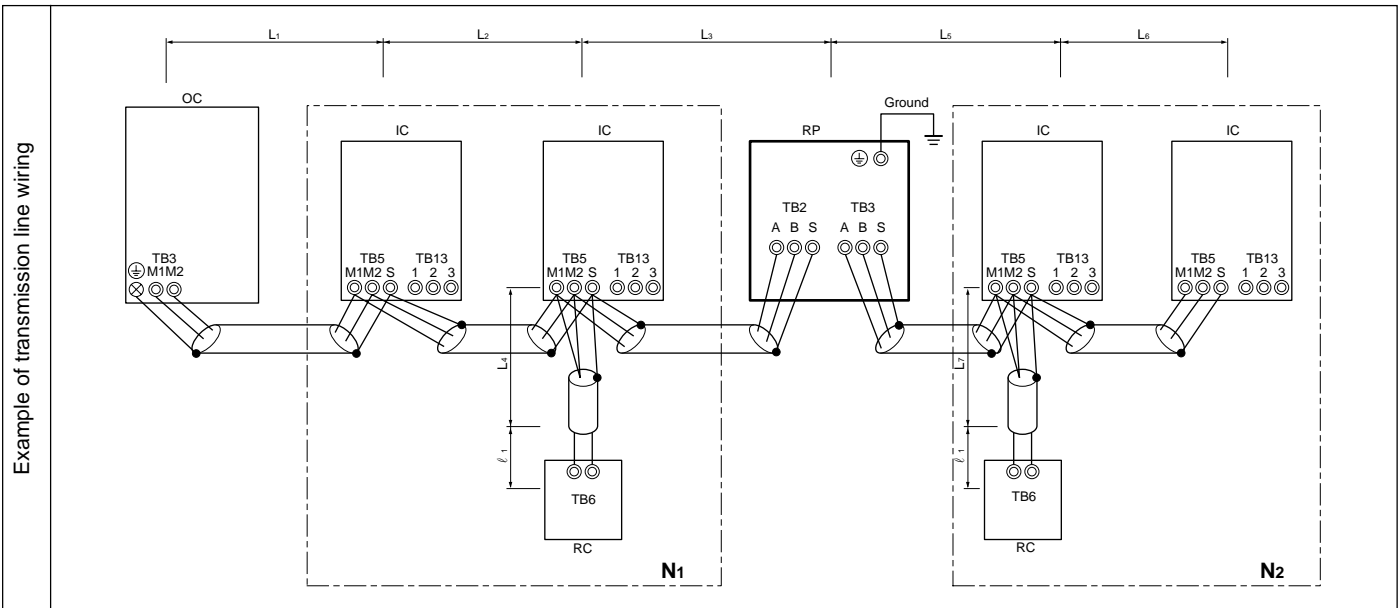

- Example of transmission line wiring
- Address settings are the same as for wiring connection examples A and B.
 - Let the number of indoor units and remote control units connected be within the limit for the number of units shown in the following table for the total of the number of units connected between the outdoor unit (OC) and the transmission booster (RP) N1 and the number of units connected after the transmission booster (RP) N2.
 - Connect the power supply ground to the transmission booster (RP) securely.
Connect the transmission lines of the outdoor unit side to terminals A and B of transmission line terminal block 1 (TB2) of the transmission booster (RP).
Connect the transmission lines of the expansion indoor unit side to terminals A and B of the of transmission line terminal block 2 (TB3) of the transmission booster (RP).

(*1) Capability of the connected indoor units	Number of connected indoor units that can be connected without a RP.	Remote controller PAR-F 25MA	
		Prior to Ver. E	After Ver. F
	200 or lower	16 (32)	20 (40)
	200 or higher	16 (32)	16 (32)

The number of indoor units and the total number of remote controllers is displayed within the parenthesis ().
*1 If even one unit that is higher than 200 exists in the cooling system, the maximum capacity will be "200 or higher".

- Permissible length
- Indoor system maximum remote wiring length:
 - $L_1+L_2+L_3+L_5+L_6 \leq 200$ m (1.25 mm²)
 - $L_1+L_2+L_3+L_5+L_7 \leq 200$ m (1.25 mm²)
 - $L_1+L_2+L_4 \leq 200$ m (1.25 mm²)
 - $L_6+L_5+L_3+L_4, L_4+L_3+L_5+L_7 \leq 200$ m (1.25 mm²)
 - Remote control wiring length: $\ell_1, \ell_2 \leq 10$ m (0.5 to 0.75 mm²)
If the length exceeds 10 m, use 1.25 mm² shielded cable and calculate the length of that portion (L4 and L7) as within the total extended length and the longest remote length.

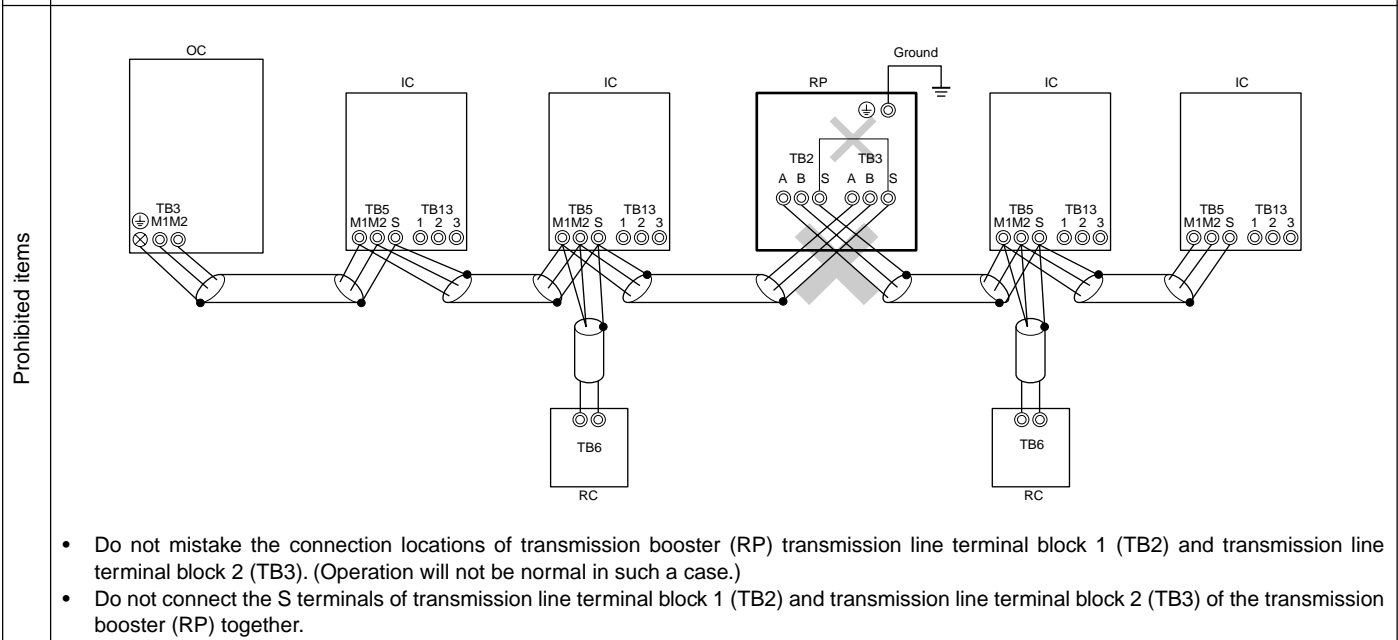

11.4. Wiring of main power supply and equipment capacity

⚠ Warning:

- Be sure to use specified wires to connect so that no external force is imparted to terminal connections. If connections are not fixed firmly, it may cause heating or fire.
- Be sure to use the appropriate type of overcurrent protection switch. Note that generated overcurrent may include some amount of direct current.

⚠ Caution:

- The reverse phase of L lines (L₁, L₂, L₃) can be detected (Error cord : 4103), but the reverse phase of L lines and N line can be not be detected.
 - The some electric parts should be damaged when power is supplied under the miss wiring.
- Some installation site may require attachment of an earth leakage breaker. If no earth leakage breaker is installed, it may cause an electric shock.
- Do not use anything other than breaker and fuse with correct capacity. Using fuse and wire or copper wire with too large capacity may cause a malfunction of unit or fire.

Schematic Drawing of Wiring (example)

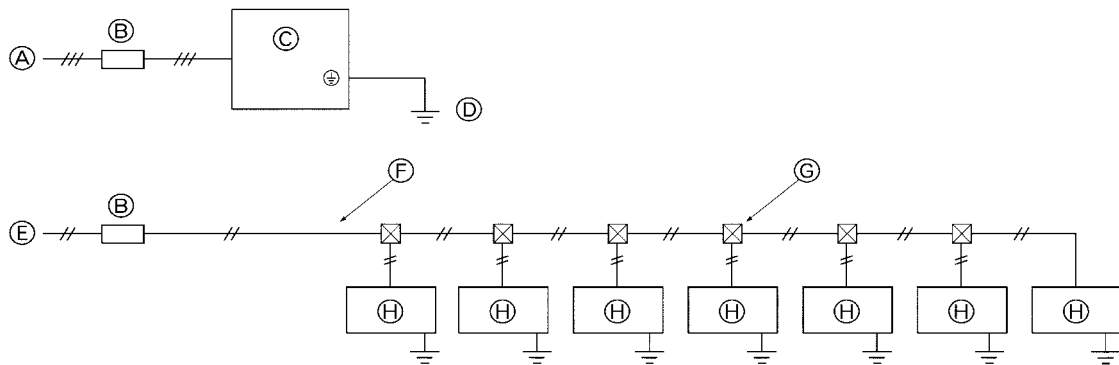

- Ⓐ Power Supply (3-Phase, 4-Wire) 380/400/415 Volt
- Ⓑ Switch
- Ⓒ Outdoor Unit
- Ⓓ Ground

- Ⓔ Power Supply (Single-Phase) 220/230/240 Volt
- Ⓕ 1.5 mm² or more
- Ⓖ Pull Box
- Ⓗ Indoor Unit

Thickness of Wire for Main Power Supply and On/Off Capacities (example)

Model		Minimum Wire Thickness (mm ²)			Switch (A)		Breaker for Wiring (NFB)	Breaker for Current Leakage
		Main Cable	Branch	Ground	Capacity	Fuse		
Outdoor Unit	PUHY-P400	10.0	–	10.0	63	63	75 A	75 A 100 mA 0.1 s. or less
	PUHY-P500	16.0	–	16.0	63	63		

Model		Wire Thickness (mm ²)			Switch (A)		Breaker for Wiring (NFB)	Breaker for Current Leakage
		Main Cable	Branch	Ground	Capacity	Fuse		
Indoor Unit	All Models	1.5	1.5	1.5	16	16	20 A	20 A 30 mA 0.1 s. or less

1. Use a separate power supply for the outdoor unit and indoor unit.
2. Bear in mind ambient conditions (ambient temperature, direct sunlight, rain water, etc.) when proceeding with the wiring and connections.
3. The wire size is the minimum value for metal conduit wiring. The power cord size should be 1 rank thicker consideration of voltage drops. Make sure the power-supply voltage does not drop more than 10%.
4. Specific wiring requirements should adhere to the wiring regulations of the region.
5. Power supply cords of parts of appliances for outdoor use shall not be lighter than polychloroprene sheathed flexible cord (design 245 IEC57). For example, use wiring such as YZW.

12. Test run

12.1. Checking before getting test run

1	Check to see whether there are refrigerant leakage, and slack of power or transmission cable.
2	Confirm that 500 V megger shows 1.0 MΩ or more between power supply terminal block and ground. Do not operate in the case of 1.0 MΩ or less. NOTE: Never carry out megohm check over terminal control board. Otherwise the control board would be broken. Immediately after mounting the unit or after leaving it turned off for an extended length of time, the resistance of the insulation between the power supply terminal board and the ground may decrease to approx. 1 MΩ as a result of refrigerant accumulating in the internal compressor. If the insulation resistance is more than 1 MΩ, turning on the main power supply and energizing the crankcase heater for more than 12 hours will cause the refrigerant to evaporate, increasing the insulation resistance.
3	Check to see whether both gas and liquid valves are fully open. NOTE: Be sure to tighten caps.
4	Check the phase sequence and the voltage between phases. NOTE: If the phase sequence is reversed, an error (4103) may occur when a test run is made, causing the unit to stop.
5	If a transmission booster is connected: Turn transmission booster power on the before turning the outdoor unit's power on. NOTE 1: If the outdoor unit's power is turned on first, refrigerant system connection data may not be recognized normally. NOTE 2: If the outdoor unit's power is turned on first, reset the outdoor unit's power after turning the transmission booster power on.
6	Turn on universal power supply at least 12 hours before getting test run in order to carry current to crank case heater. If current-carrying hours are too short, it may result in a malfunction of compressor.

12.2. Test run method

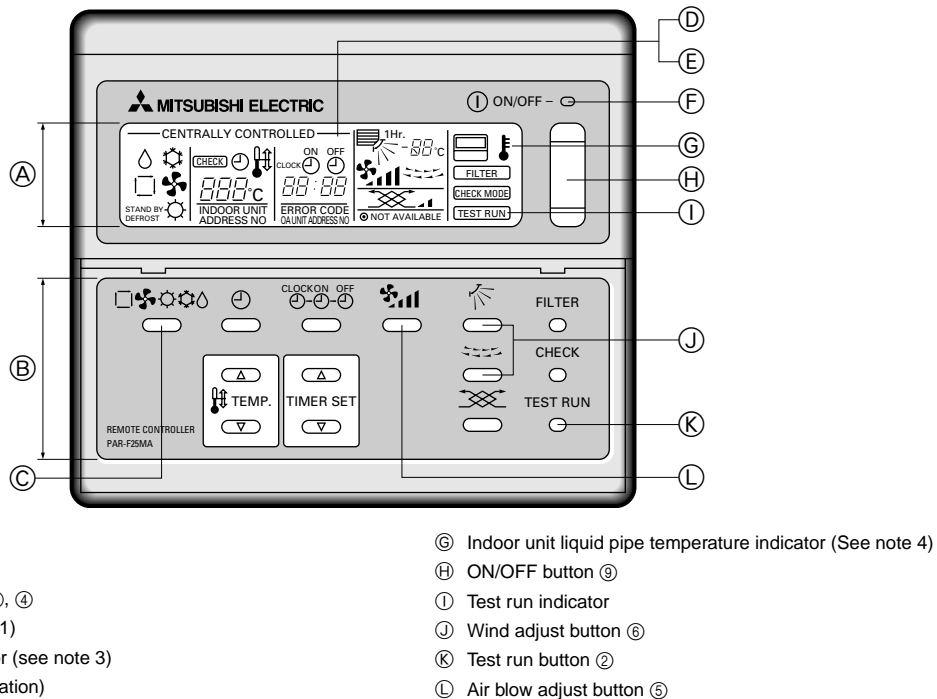

Operation procedure	
①	Turn on universal power supply at least 12 hours before getting started → Displaying "HO" on display panel for about two minutes. The universal power supply must be left on for at least 12 hours (with the crank case heater turned on). If a transmission booster is connected, turn transmission booster power on the before turning the outdoor unit's power on.
②	Press [TEST RUN] button twice → Displaying "TEST RUN" on display panel.
③	Press [Cooling/Heating] select button → Make sure that air is blowing out.
④	Press [Cooling/Heating] select button to change from cooling to heating operation, and vice versa → Make sure that warm or cold air is blowing out.
⑤	Press [Wind] adjust button → Make sure that air blow is changed.
⑥	Press [Up/Down Wind] or [Louver] button to change wind → Make sure that horizontal or downward blow is adjustable.
⑦	→ Make sure that indoor unit fans operate normally.
⑧	Make sure that interlocking devices such as ventilator operate normally if any.
⑨	Press [ON/OFF] button to cancel test run → Stop operation.
NOTE 1: If check code is displayed on remote controller or remote controller does not operate normally, see page 33 or further.	
NOTE 2: Test run automatically stops operating after two hours by activation of timer set to two hours.	
NOTE 3: During test run, test run remaining time is displayed on time display section.	
NOTE 4: During test run, temperature of liquid pipe in indoor unit is displayed on remote controller room temp. display section.	
NOTE 5: When pressing [Wind] adjust button, depending on the model, "This function is not available" may be displayed on remote controller. However, it is not a malfunction.	

12.3. How to cope with test run abnormality

① A 4-digit check code is displayed on remote controller display panel if unit is stopped due to an abnormality. Check to see causes of that abnormality.

1. Indoor unit

Check code	Check Content	Check code	Check Content	
2500	Leakage (water) abnormality	6602	Transmission processor hardware abnormality	
2502	Drain pump abnormality	6603	Transmission circuit bus-busy abnormality	
2503	Drain sensor abnormality	6606	Communications with transmission processor abnormality	
4116	Fan speed abnormality (motor abnormality)	6607	No ACK abnormality	
5101	Thermal sensor abnormality	6608	No response abnormality	
5102		Air inlet (TH21)	7101	Capacity code abnormality
5103		Liquid pipe (TH22)	7111	Remote control sensor abnormality
6600	Gas pipe (TH23)			
6600	Multiple address abnormality			

2. Outdoor unit

Check code	Check Content	Check code	Check Content
0403	Serial transmission abnormality	5101	Thermal sensor abnormality
1102	Discharge temperature abnormality	5102	
1111	Low pressure saturation temperature sensor abnormality (TH2)	5103	
		5104	
1112	Liquid level sensing temperature sensor abnormality (TH4)	5105	
		5106	
1113	Liquid level sensing temperature sensor abnormality (TH3)	5107	
		5108	
1301	Low pressure abnormality	5109	
1302	High pressure abnormality		
1500	Overcharged refrigerant abnormality	5110	
1501	Low refrigerant abnormality	5114	Compressor shell temperature (TH10)
1505	Suction pressure abnormality	5201	Pressure sensor abnormality
4103	Reverse phase abnormality	5301	IDC sensor/circuit abnormality
4108	Overcurrent protection (51C2)	6600	Multiple address abnormality
4115	Power supply sync signal abnormality	6602	Transmission processor hardware abnormality
4200	VDC sensor/circuit abnormality	6603	Transmission circuit bus-busy abnormality
4210	Breaking of overcurrent	6606	Communications with transmission processor abnormality
4220	Bus voltage abnormality	6607	No ACK abnormality
4230	Radiator panel overheat protection	6608	No response abnormality
4240	Overcurrent protection	7100	Total capacity abnormality
4260	Cooling fan abnormality	7101	Capacity code abnormality
		7102	Connected unit count over
		7105	Address setting abnormality

3. Remote controller

Check code	Check Content	Check code	Check Content
6101	Unreadable response receiving error	6606	Communications with transmission processor abnormality
6600	Multiple address abnormality	6607	SC coil outlet (TH7)
6602	Transmission processor hardware abnormality	6608	SC coil bypass outlet (TH8)
6603	Transmission circuit bus-busy abnormality		

② Diagnostic switch (SW1) and the service LED on multi-controller board of indoor unit can be used to judge a malfunction of outdoor unit.
 <Operation of self-diagnosis switch (SW1) and the service LED display>

Self-diagnosing item	SW1 setting	Display at LED lighting (blinking)								Remarks	
		Flag 1	Flag 2	Flag 3	Flag 4	Flag 5	Flag 6	Flag 7	Flag 8		
③	Relay output display 1 (Lighting)	During compressor run		Compressor 1 operations	Compressor 2 operations	21S4	SV1		SV22/32	Always lighting	Flag 8 always lights at microcomputer power ON
	Check display 1 (Blinking)	0000 to 9999 (Alternate display of address and error code)									
	Relay output display 2	SV4	21S4b	SV5b	SV6	CH2, 3	52F			21S4b and SV5b are closed with flag 1	
④	Check indoor unit	No.1 unit	No.2 unit	No.3 unit	No.4 unit	No.5 unit	No.6 unit	No.7 unit	No.8 unit	Lights at emergency stop in IC Turns off by resetting	
		No.9 unit	No.10 unit	No.11 unit	No.12 unit	No.13 unit	No.14 unit	No.15 unit	No.16 unit		
		No.17 unit	No.18 unit	No.19 unit	No.20 unit						
⑤	Indoor unit mode	No.1 unit	No.2 unit	No.3 unit	No.4 unit	No.5 unit	No.6 unit	No.7 unit	No.8 unit	Lights at cooling Blinks at heating Turns off at stop/fan	
		No.9 unit	No.10 unit	No.11 unit	No.12 unit	No.13 unit	No.14 unit	No.15 unit	No.16 unit		
		No.17 unit	No.18 unit	No.19 unit	No.20 unit						
⑥	Indoor unit thermostat	No.1 unit	No.2 unit	No.3 unit	No.4 unit	No.5 unit	No.6 unit	No.7 unit	No.8 unit	Lights at thermostat on Turns off at thermostat off	
		No.9 unit	No.10 unit	No.11 unit	No.12 unit	No.13 unit	No.14 unit	No.15 unit	No.16 unit		
		No.17 unit	No.18 unit	No.19 unit	No.20 unit						
Indoor unit address	Displays in order the addresses (1 through 50) of all indoor units connected to the outdoor unit.										

- ③ Outdoor unit ④ Indoor unit
- Ⓐ ON Ⓑ OFF Ⓒ At factory shipment

ENGLISH

Displaying the service LED

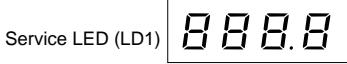

- Error code display
Alternate display of error generating address and error code
Example At outdoor unit address 51, abnormal discharge temperature (Code 1102)
- Flag display
Example SV1 ON under only compressor 1 operated

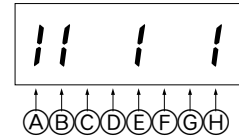
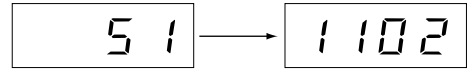

- Ⓐ Flag 1 Ⓔ Flag 5
- Ⓑ Flag 2 Ⓕ Flag 6
- Ⓒ Flag 3 Ⓖ Flag 7
- Ⓓ Flag 4 Ⓗ Flag 8

12.4. Coping with remote controller abnormality

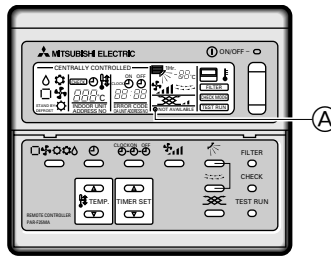

Ⓐ Display: Appears when current is carried

	Phenomenon	Cause	How to cope with abnormality
1	Unit does not operate and display stays off even after pressing remote controller ON switch. (Current-carrying indicator does not light up)	(1) Outdoor unit power was not turned on. (2) Transmission or remote controller cable was shorted or connection failure. (3) Power cable contact failure. (4) Remote controller was erroneously connected to unit remote controller terminal block. (5) Too many remote controllers or indoor units were connected.	(a) Check voltage between remote controller terminals. (i) Remote controller fails when voltage is 17 to 30 V. (ii) If there is no voltage <ul style="list-style-type: none"> • Check the number of remote controllers and indoor units connected. • Remove wire from transmission cable terminal block (TB3) on outdoor unit, and check voltage between terminals. <ul style="list-style-type: none"> • If voltage is 17 to 30 V, check (2) and (4) at left. • If there is no voltage, check (1) and (3) at left.
2	"HO" indicator does not disappear. Unit does not operate even if the switch is pressed.	(1) No transmission cable was connected to transmission cable terminal block on the indoor unit. (2) Outdoor unit address was erroneously set. (3) Indoor unit address was erroneously set.	<ul style="list-style-type: none"> • Check all items at left.
3	Display comes on once but disappears immediately after a press of the switch.	(1) Indoor unit power was not turned on.	<ul style="list-style-type: none"> • Check item at left.

12.5. The following phenomena do not represent abnormality (emergency)

Phenomenon	Display of remote controller	Cause
Indoor unit does not perform cooling (heating) operation.	"Cooling (heating)" flashes	When another indoor unit is performing the heating (cooling) operation, the cooling (heating) operation is not performed.
The auto vane runs freely.	Normal display	Because of the control operation of auto vane, it may change over to horizontal blow automatically from the downward blow in cooling in case the downward blow operation has been continued for 1 hour. At defrosting in heating, hot adjusting and thermostat OFF, it automatically changes over to horizontal blow.
Fan setting changes during heating.	Normal display	Ultra-low speed operation is commenced at thermostat OFF. Light air automatically changes over to set value by time or piping temperature at thermostat ON.
Fan stops during heating operation.	Defrost display	The fan is to stop during defrosting.
Fan does not stop while operation has been stopped.	No lighting	Fan is to run for 1 minute after stopping to exhaust residual heat (only in heating).
No setting of fan while start SW has been turned on.	Heat ready	Ultra low-speed operation for 5 minutes after SW ON or until piping temperature becomes 35°C, low speed operation for 2 minutes thereafter, and then set notch is commenced. (Hot adjust control)
Outdoor unit does not operate by turning switch on.	Normal display	When the outdoor unit is being cooled and the refrigerant is resting, warming up operation is performed for at least 35 minutes to warm the compressor. During this time, only the fan operates.
Indoor unit remote controller shows "HO" indicator for about two minutes when turning ON universal power supply.	"HO" flashes	System is being driven. Operate remote controller again after "HO" disappear.
Drain pump does not stop while unit has been stopped.	Light out	After a stop of cooling operation, unit continues to operate drain pump for three minutes and then stops it.
Drain pump continues to operate while unit has been stopped.		Unit continues to operate drain pump if drainage is generated, even during a stop.

This product is designed and intended for use in the residential,
commercial and light-industrial environment.

The product at hand is
based on the following
EU regulations:

- The equipment Safety Law (GSG) accepted
by RW-TUV.
- Low Voltage Directive 73/23/EEC
- Electromagnetic Compatibility Directive 89/
336/EEC
- Machinery Directive 89/392/EEC

Please be sure to put the contact address/telephone number on
this manual before handing it to the customer.