

SERVICE PARTS LIST FOR MITSUBISHI ELECTRIC PACKAGED AIR-CONDITIONERS

Series PUHY-P-YMF-B

For use with the R407C

**REVISED
Jul. 2003**

INDEX

P U H Y - P 2 0 0 Y M F - B

P U H Y - P 2 5 0 Y M F - B



PUHY-P200YMF-B
PUHY-P250YMF-B

EXTERNAL PARTS

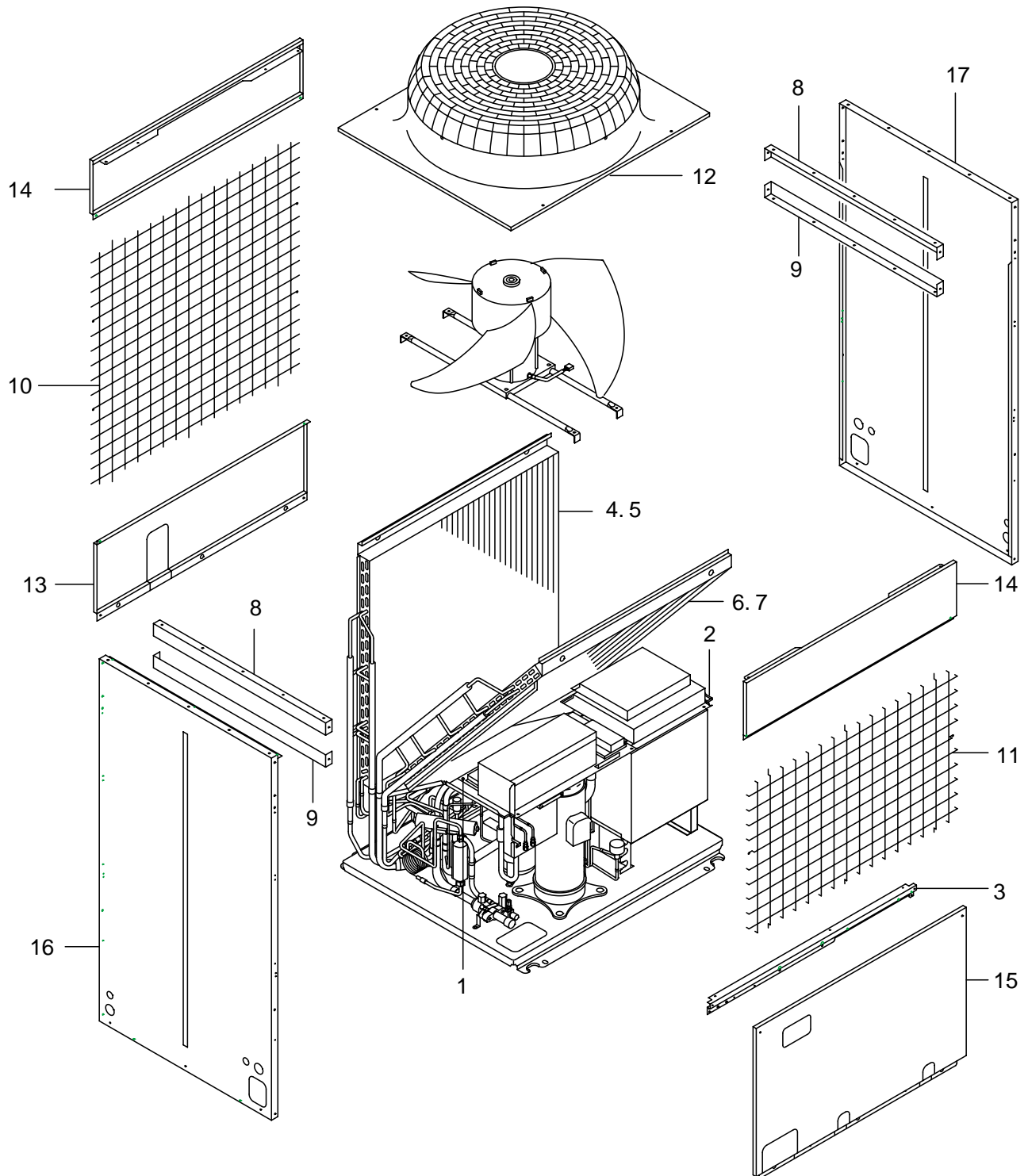

PUHY-P200YMF-B
PUHY-P250YMF-B

FUNCTIONAL PARTS

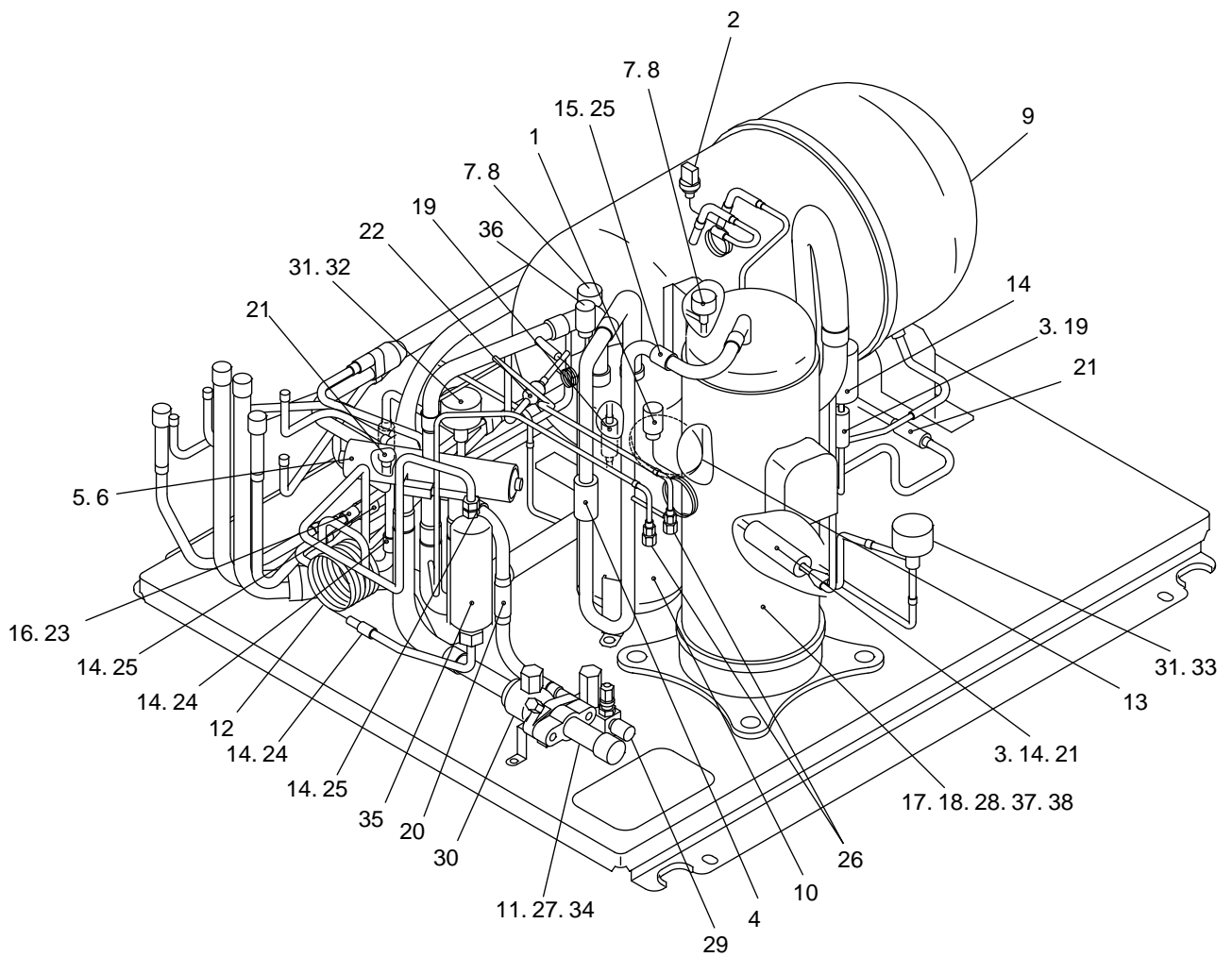

PUHY-P200YMF-B
 PUHY-P250YMF-B

CONTROL BOX PARTS

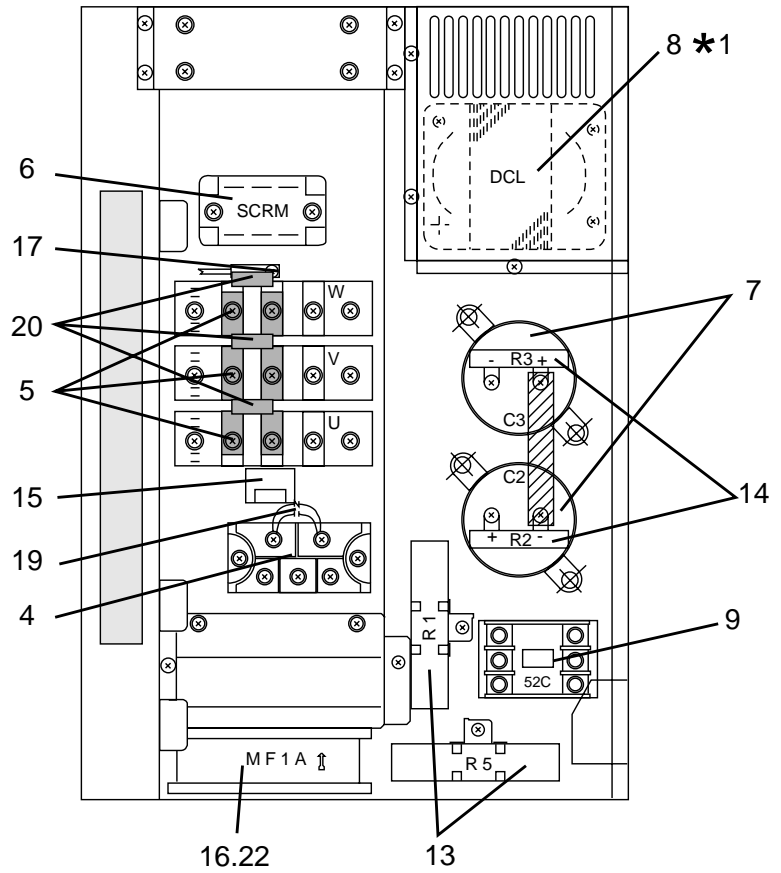
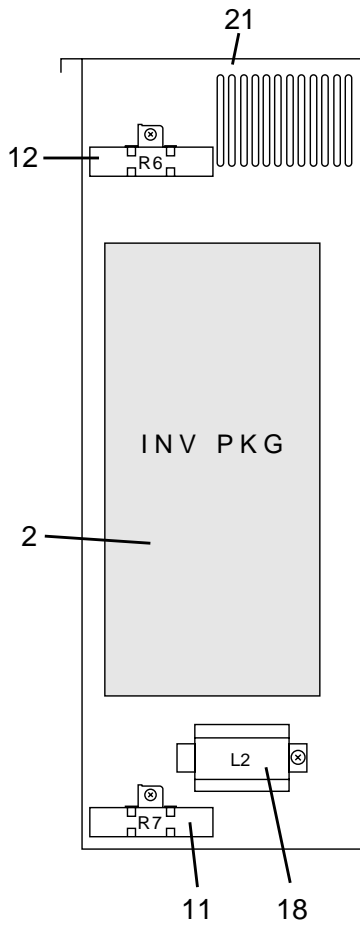

*1: It may be needed to process the hole for attaching parts into the metal plate of Control box.

